

**CZECH UNIVERSITY OF LIFE SCIENCES PRAGUE**

**Faculty of Tropical AgriSciences**



**Chemical analysis of *Opuntia* (*Opuntia* spp.) oil**

**BACHELOR'S THESIS**

Prague 2023/2024

**Author:** Tali-Maamarová Amal

**Supervisor:** doc. Ing. Klára Urbanová, Ph.D.

## **Declaration**

I hereby declare that I have done this thesis entitled “Chemical analysis of *Opuntia* (*Opuntia* spp.) oil” independently, all texts in this thesis are original, and all the sources have been quoted and acknowledged by means of complete references and according to Citation rules of the FTA.

In Prague date

.....  
Amal Tali-Maamarová

## **Acknowledgements**

I am very grateful for my supervisor, doc. Ing. Klára Urbanová, PhD. for her patience, willingness to help, valuable advice and constant feedback. She was always there when I had any questions.

I would also like to thank the Faculty of Tropical AgriSciences for the opportunity to conduct the practical research in the laboratory.

## **Abstract**

With the current impact of global warming, the number of countries facing drought and water shortages is increasing. This also leads to many food security challenges. *Opuntia* spp. was often an underestimated crop therefore due to the changing climate, it has been studied to understand the valuable advantages and utilisation potential that this drought-resistant crop has to offer.

To valorise *Opuntia* and broaden the knowledge about the benefits of its extremely valuable seed oil, this study aimed to determine, identify, and compare bioactive compounds of commercially available *Opuntia ficus-indica* seed oil with *Opuntia ficus-indica* seed oil extracted from its fruits originating from differing countries by the solvent-based Soxhlet extraction method. Samples were analysed by gas chromatography coupled with mass spectrometry.

In total, 15 fatty acids were detected. The results also confirmed the presence of the dominating fatty acids linoleic, oleic, stearic, palmitoleic and behenic acid. Results between the samples differed and considerable deviations in concentrations were found in comparison with literature data.

**Key words:** *Opuntia*, seed oil, GC/MS, health benefits, prickly pear, fatty acids

# Contents

<b>1. Introduction .....</b>	<b>1</b>
<b>2. Literature Review .....</b>	<b>3</b>
2.1. Opuntia .....	3
2.1.1. Botanical overview .....	3
2.1.2. Cultivation and propagation .....	4
2.1.3. Post-harvest handling.....	5
2.1.4. Socio-economic importance .....	5
2.1.5. Utilisation and derived products .....	8
2.1.6. Medicinal benefits .....	9
2.1.6.1. Antioxidant properties .....	9
2.1.6.2. Antimicrobial properties .....	10
2.1.6.3. Anti-inflammatory activity .....	10
2.1.6.4. Cholesterol-reducing properties.....	11
2.1.6.5. Hangover-alleviating action.....	12
2.1.6.6. Dermatologic properties .....	12
2.2. Bioactive compounds .....	12
2.2.1. Linoleic acid .....	12
2.2.2. Oleic acid .....	13
2.2.3. Palmitoleic acid .....	14
2.2.4. Stearic acid.....	14
2.2.5. Behenic acid.....	15
2.3. Chromatography .....	16
2.3.1. Gas chromatography .....	16
2.4. Mass spectrometry .....	18
2.5. Extraction methods .....	19
2.5.1. Soxhlet extraction .....	20
2.5.2. Cold-press extraction .....	21
2.6. Scientific studies on this issue .....	22
<b>3. Aims of the Thesis.....</b>	<b>25</b>
3.1. Main objective .....	25

3.2.	Specific objectives .....	25
<b>4.</b>	<b>Methods and materials .....</b>	<b>26</b>
4.1.	Samples.....	26
4.1.1.	Commercially available OFI seed oil .....	26
4.1.2.	Plant material .....	27
4.2.	Fruit preparation and seed extraction .....	28
4.3.	Oil extraction and GC/MS analysis .....	29
4.3.1.	Oil extraction .....	29
4.3.2.	Transesterification .....	29
4.3.3.	GC/MS analysis of Fatty Acids .....	30
4.4.	Data analysis.....	31
<b>5.</b>	<b>Results.....</b>	<b>32</b>
<b>6.</b>	<b>Discussion .....</b>	<b>36</b>
<b>7.</b>	<b>Conclusions .....</b>	<b>38</b>
<b>8.</b>	<b>References.....</b>	<b>39</b>

## List of tables

Table 1: Taxonomic classification of <i>Opuntia</i> .....	3
Table 2: Fatty acid composition of <i>Opuntia</i> seed oils from Tunisia .....	22
Table 3: Percentages of FAMES in crude cactus pear seed oil extracts from Mexico... 23	
Table 4: Fatty acids content identified in the OFI seed oil from Algeria .....	24
Table 5: Identified fatty acids in <i>Opuntia</i> seed oil samples.....	33

## List of figures

Figure 1: Chemical structure of linoleic acid .....	12
Figure 2: Chemical structure of oleic acid.....	13
Figure 3: Chemical structure of palmitoleic acid .....	14
Figure 4: Chemical structure of stearic acid.....	15
Figure 5: Chemical structure of behenic acid.....	15
Figure 6: Schematic diagram of gas chromatography .....	17
Figure 7: Conventional Soxhlet apparatus.....	20
Figure 8: Sample 1.....	27
Figure 9: Sample 2.....	27
Figure 10: Sample 3.....	28
Figure 11: Sample 4.....	28
Figure 12: Extraction and preparation of OFI seeds from Colombia and Spain .....	28
Figure 13: Extracted oil .....	29
Figure 14: Purchased oil .....	29
Figure 15: Oil samples during transesterification .....	30
Figure 16: Oil samples ready for GC/MS analysis.....	30
Figure 17: Chromatograms of oil samples (from top to bottom: sample 1, sample 2, sample 4, sample 3) .....	34
Figure 18: Mass spectrum of octadeca-9,12-dienoic acid, methyl ester .....	35

## **List of the abbreviations used in the thesis**

CGIAR – Consultative Group on International Agricultural Research

COSMOS – Cosmetic Organic and natural Standard

FAME – Fatty acid methyl esters

FAO – Food and Agriculture Organisation of the United Nations

GC – Gas chromatography

GC/MS – Gas chromatography / mass spectrometry

GLC – Gas-liquid chromatography

GSC – Gas-solid chromatography

ICARDA – International Center for Agricultural Research in the Dry Areas

MS – Mass spectrometry

OFI – *Opuntia ficus-indica*

RT – Retention time

Spp. – several species

TAG - Triacylglyceride



# 1. Introduction

*Opuntia* spp., also known as cactus pear, prickly pear or Barbary fig is a succulent plant of *Cactaceae* family (Reda & Atsbha 2019). This plant is native to Mexico, however nowadays it is found across the globe in arid and semi-arid regions in wild or domesticated forms. The most common species is currently *Opuntia ficus-indica* (Domenico 2021).

Due to global warming, this underestimated multipurpose fruit crop is becoming increasingly important as it is a drought-resistant crop that is able to withstand harsh climatic conditions. This makes it a key player in food security (FAO 2017).

The increasing popularity of prickly pears is due to their incredible versatility and ecological and economic advantages. Every part of this crop (apart from the thorns) can be somehow utilised or processed. The fruits can be processed into jams, jellies or juice, dried flowers can be used in teas and infusions, in some cultures, cladodes are traditionally grilled and consumed, but they are also commonly used as livestock fodder. Cladodes also have an interesting bioenergy potential.

Seeds that represent 15 % of the edible fruit are used for valuable seed oil production that is becoming renowned mainly in the cosmetic industry for its anti-ageing properties. Even the by-product of seed oil production, press cakes have been found to be a cheap source of fibres with potential use as additive ingredient (Inglese et al. 2018; Al-Naqeb et al. 2021; Domenico 2021).

With all these different applications, prickly pear is an important source of employment and income, mainly in the rural areas.

The increasing demand for natural, healthy products is also a factor in the rising *Opuntia* success. Different parts of the plant as well as its oil were shown to have various medicinal and therapeutic benefits, such as antioxidant, antimicrobial, anti-inflammatory, cholesterol-reducing and dermatological properties.

This thesis is focused on the *Opuntia* seed oil extraction and subsequent analysis of its bioactive compounds. Among all the four analysed samples, two *Opuntia ficus-indica* seed oil samples were purchased, one from the Czech market and one available in the

French market. The latter two *Opuntia ficus-indica* oil samples were obtained after the seed oil extraction. All the analysed oils are from a different country of origin. Gas chromatography mass-spectrometry was used as the analytical method to identify and determine the bioactive compounds found in the oils. The samples were compared with each other and relevant literature data.

## 2. Literature Review

### 2.1. Opuntia

#### 2.1.1. Botanical overview

The *Opuntia* sp., commonly known as prickly pear, Barbary fig or nopal is a succulent plant that belongs to *Plantae* kingdom and is part of the *Cactaceae* family (Reda & Atsbha 2019; Kiralan et al. 2021). According to some recent studies, there are around 1,500 known species of over 130 genera from the *Opuntia* genus (Aruwa et al. 2018; Reda & Atsbha 2019; Tahir et al. 2019; Kiralan et al. 2021). The most common species is *Opuntia ficus-indica*, native to Mexico (Bakewell-Stone 2023).

This slow growing perennial shrub can attain 3-7 m of growth (Aruwa et al. 2018; Bakewell-Stone 2023). Flat stem segments, named cladodes, are of an oblong shape, with a length of 20-60 cm and width of 10-40 cm. Their colour is green to blue-green. Cladodes in terminal stage are brightly green and produce cup-shaped flowers. Yellow or orange flowers bloom from the tip of the cladode and are around 6-7 cm long. Spines are usually yellow, in some varieties absent. The edible fruit is firstly green coloured, then the colour changes with the ripening process to yellow, orange, red or purple, based on the cultivar. The shape of the fruit is oblong, and the size 5-10 cm in length and 4-9 cm across. There are around 150-400 circular discoid seeds that can be yellow to tan and about 5 mm long (Bakewell-Stone 2023).

**Table 1:** Taxonomic classification of *Opuntia*

Classification	
Kingdom	<i>Plantae</i> - Plants
Subkingdom	<i>Tracheobionta</i> - Vascular plants
Superdivision	<i>Spermatophyta</i> - Seed plants
Division	<i>Magnoliophyta</i> - Flowering plants
Class	<i>Magnoliopsida</i> - Dicotyledons
Subclass	<i>Caryophyllidae</i>
Order	<i>Caryophyllales</i>
Family	<i>Cactaceae</i> Juss. - Cactus family
Genus	<i>Opuntia</i> Mill. - prickly pear
Species	<i>Opuntia ficus-indica</i> (L.) Mill. - Barbary fig

Source: USDA, NRCS. The PLANTS Database

### **2.1.2. Cultivation and propagation**

The species grows well in diverse parts across the world, all through arid and semi-arid regions. It can be found in North and South America in countries such as Mexico, Canada, the United States, Argentina, Brazil, Chile, it is also abundant in countries of the Mediterranean region such as Italy and Spain, but also North African countries as Morocco, Algeria, Tunisia, Egypt. It is important to mention that the genus is found in South Africa as well (Del Socorro Santos Díaz et al. 2017; Aruwa et al. 2018; Brahmi et al. 2020; Kiralan et al. 2021).

As already stated, *Opuntia* is a plant found across different regions. This demonstrates the plant's great adaptability to different conditions. Ideally, it grows in volcanic, loose, medium-textured soils, however, it is found in dry, poor and rocky soils as well. The plant is drought resistant thanks to its water reserve and tolerates higher temperatures. The best climatic conditions are temperatures around 10-15 °C during the winter period and 30-35 °C throughout the summer. Concerning the altitude, prickly pear cactus can be found up to 1,000 m above sea level (Domenico 2021).

*Opuntia* cactus can be propagated by seeds or vegetatively. If they are propagated by seeds, *Opuntia* is sown early spring in a greenhouse and later transferred to pots for two winters. Afterwards, either during the late spring or early summer period they are planted outdoors (Bakewell-Stone 2023). The second way of propagation which is vegetative, produces the exact plant to the original one from which it was derived (Domenico 2021). This propagation method can be realised by using pieces of cladodes, flower buds or fruit. Using stem segments with up to three cladodes and the basal cladode planted only partially in the soil, new roots will form after the period of 2 weeks, mainly if it is planted in the spring. To minimize the risk of fungal infections, it is advised to let the separated cladodes dry for at least one week before planting (Bakewell-Stone 2023).

The optimal way to plant *Opuntia* cactus would be to leave 6-7 m between rows and plant it 4-5 m apart within the rows (Domenico 2021).

Production can reach 30 tonnes per hectare in the case of specialized productions (Domenico 2021). However, the number is usually lower, as the growers tend to reduce the amount of the fruits on the blades to allow thinning, which will improve the quality value of the produce. The fruit thinning is done in July, after the berries have set (Le

Houérou 1996). The typical production per hectare is 15-20 tonnes. In case of small-holder farmers the production of individual trees is 40 kg of fruit after a period of 5 years. *Opuntia* is harvested when the fruit is ripe, which is assessed based on the colour of the skin. The colour differs based on the species/cultivars. The best time for harvesting is in the morning as the thorns are less rigid thanks to the moisture. As the fruit must be picked by hand, it is essential to use thick gloves and a sharp knife. It is necessary that the cut is clean to avoid the spoilage of the fruit (Domenico 2021). The fruits tend to be tender, even though the plant can bear harsh conditions.

It is important to carefully manipulate with the fruit, as during harvest time, it is common to find physiological loosening in the area connecting the fruit to the cladode. Improper manipulation as pulling or twisting could lead to an injury at the stem. For commercial purposes it is crucial to cut at the base of the fruit to leave a piece of cladode attached (Inglese et al. 2018).

### **2.1.3. Post-harvest handling**

Contrary to most types of fruit, the post-harvest handling in case of prickly pear is quite simple. The first and the main post-harvest handling operation is despination, which in case of countries where the fruits are for the local market, is still done manually—the fruits are spread on grass and brushed with brooms (Cantwelp et al. 1992). On the other hand, the despination can be done in packing lines by dry brushing. This occurs mainly with fruit destined for distant markets. Fruit grading is done based on three main aspects, which are cultivar, category, and weight. The packaging of the fruit takes place on the day of harvest and directly delivered under refrigerated conditions. Usually, the cactus fruit is packed in plastic trays containing 6-8 fruits (Inglese et al. 2018).

Prior to the sale, the fruit can be stored for up to 60-70 days if the place is cool and well ventilated. It can be kept in refrigerator rooms at the temperature of 3 °C. If the temperature is lower, the fruit can soften. It is important to mention that there should be also appropriate air circulation and a relative humidity level of 90 % (Domenico 2021).

### **2.1.4. Socio-economic importance**

*Opuntia* spp. is often an underestimated crop, however, its various health benefits, different utilisations and possible derived products make it a multi-purpose plant with

interesting economic value for the producing countries. Native to Mexico, nowadays cactus pear is a plant that is found throughout the globe in arid or semi-arid regions.

In many countries across the continents, cactus pear is typically found mainly in the local markets as it is used as a subsistence crop. Only few countries produced cactus pear with the commercial aim. Those include mainly Mexico, Italy, South Africa. Other important producing countries are Argentina, Chile, Bolivia, Peru, Colombia, United States of America, Morocco, Algeria, Libya, Tunisia, Egypt, Jordan, Pakistan, Israel, Greece, Spain and Portugal.

Mexico is the leader among global producers, representing 45 % of the world's prickly pear production. The land area dedicated to cactus cultivation ranges from 50,000 to 70,000 ha with the gross annual production 300,000-500,000 tonnes. It is a crucial crop in the region as it generates employment and income for about 20,000 families. Italy ranks as the second world producer and main exporter, with the prickly pear production concentrated mainly in Sicily on 7,000-8,300 ha and average annual yield of 78,000-87,000 tonnes. South Africa ranks third, with about 15,000 tonnes of prickly pear cultivated on 1500 ha land (García et al. 2020). However, it is important to mention that the yields of commercially cultivated prickly pear can differ based on the geographic location, cultivar and growing technique (FAO 2017).

The global interest in prickly pear is on the rise, as many countries are already being affected by climate change and facing water shortages. In fact, due to the prickly pear's horizontally spreading shallow roots, the plant is able to absorb water from the soil in an efficient manner with about 87 % of water is stored in the cladodes (Ciriminna et al. 2017). Another ecological advantage is the ability of CO<sub>2</sub> absorption due to Crassulacean acid metabolism (CAM). This mechanism is specific to succulent plants. It allows the plants to fix CO<sub>2</sub> at night, when the evapotranspiration is the lowest, while storing it as organic acids. Therefore, water use is efficient as carbon dioxide is released during the day and refixed by usual photosynthesis reaction occurring during the day. Shortly, the whole process results in lower water loss during photosynthesis (Alshaikhi et al. 2023). Feeding cactus to cattle was proven to have a methanogenesis reducing effect on ruminants, resulting in lower greenhouse gas emissions (FAO 2017).

Opuntia plants are an important component of agricultural systems as they stand out in the ability to thrive in degraded soils that the majority of crops cannot withstand. During

the dry season, many animals and livestock rely on eating this crop (Hänke et al. 2018; Alshaikhi et al. 2023). The water retained in the pads creates a “botanical well” supplying up to 180 tonnes of water per one hectare, enabling to sustain five adult cows. The survival rate of livestock was proven to be higher in farms with cactus plantations (FAO 2017).

Due to the great adaptability, resilience and widespread use of *Opuntia*, FAO (Food and Agriculture Organisation of the United Nations) and the CGIAR (Consortium of International Agricultural Research Centres), which is the world’s largest global agricultural innovation network, carried out projects in order to improve the cultivation, marketing and distribution processes with the aim to enable farmers to obtain products with added value and improve their livelihoods (FAO 2018; Alshaikhi et al. 2023; Hassan et al. 2023). Furthermore, as a result of all the advantages associated with prickly pear, FAO established the FAO-ICARDA Cactus Network, which is an international *Opuntia* research and development program (Hänke et al. 2018).

One of the most precious oils can be extracted from *Opuntia* seeds, which could provide a valuable income alternative. The current prices of *Opuntia* vary, depending on the fact if the oil is coming from an organic or conventional production. The prices of conventional *Opuntia* oil are between 275 to 700 Euros per litre. On the other hand, the organic *Opuntia* oil ranges from 900 and 1,500 Euros per litre. The oil is mainly produced from *Opuntia ficus-indica* cultivar, mostly from North African producer countries – Algeria, Morocco, and Tunisia. It is important to mention, that the prices depend on the purity extent and quality, thus, the prices can fluctuate (Hänke et al. 2018).

Furthermore, the expansion of cactus pear seed oil commercialisation could provide women with empowerment in the local households. For instance, in Madagascar, the production of fodder from the prickly pear plants is considered to be a male occupation, whereas fruit gathering and selling the products is a female occupation. If this traditional labour division persists, it is very likely that by producing and selling seed oil, more work opportunities would be available for women, and it would strengthen their economic position (Kaufmann 2004; Hänke et al. 2018).

Argan oil is ranked among the most expensive oils, due to high demand and limited supply. However, prickly pear seed oil may soon be in the same situation. Although OFI oil is still extracted in low quantities, it is utilised in cosmetic products that treat the skin

and hair. However, due to its significant health benefits, cactus pear oil might be a significant element in nutritional supplements, sports drinks and other products. Similarly to Argan oil, Opuntia oil promotes anti-aging effects by scavenging free radicals and reduces redness. But, OFI oil contains more vitamin E, which makes these effects more durable (Ciriminna et al. 2017).

Prickly pear will most likely rank between the most valuable commodities soon. That would be a result of several factors. Firstly, the fruit is widely distributed across the globe, unlike Argan, that is produced only in Morocco. Secondly, the price of the OFI fruit is widely available and cheap. Thirdly, there is an increasing demand for natural products in cosmetics, medicine, and food, which is linked to the therapeutic, medicinal and nutritional benefits of prickly pear (Ciriminna et al. 2017).

#### **2.1.5. Utilisation and derived products**

Prickly pear is a versatile plant with various uses and many by-products. The fruit can be further processed in the form of juice, jams, or teas (Al-Naqeb et al. 2021). In most of the countries only the fruit part is consumed, however, in Mexico even the tender cladodes are eaten. In Sicily, prickly pear flowers are picked and dried for infusions, that have purifying effects. Prickly pear has a significant importance as livestock feed as well, as they're harvested as fodder plants and fed at the feeding through (Domenico 2021).

The seeds obtained from the fruit typically represent about 15 %, on average 10-15 grams of seed per 100 grams of fruit. The average oil content is 9.5 grams per 100 grams of seeds (Ramadan & Mörsel 2003). The oil has high amounts of fatty acids, and high content of natural antioxidants such as tocopherols (vitamin E), which make it attractive for pharmaceutical and cosmetic industries (Matthäus & Musa Özcan 2011; Ghazi et al. 2013). Furthermore, the by-product generated during the seed oil production, press cakes, have been found to contain high amounts of dietary fibres, healthy amino-acids and antioxidant properties, which makes them a cheap fibre source with ideal implementation as an additional ingredient valorising many food formulations (Masmoudi et al. 2021).

In rural areas, renewable energy plays a crucial role as it provides endless energy supply for rural communities. A practical source of energy is biogas production that results from anaerobic digestion of organic waste. Specifically in dry regions, there is less amount of organic waste available, which is a significant drawback for biogas production. However,



prickly pear is a drought-resistant crop with high potential for biomass production. Moreover, cactus cladodes are suitable for bioethanol and biogas production (Inglese et al. 2018; García et al. 2020).

Additionally, pigments from red and purple cactus pear obtained by using the microencapsulation process of betalains could be used as additives in food industry goods, in dairy products or sweets and desserts (García et al. 2020).

*Opuntia* cladodes are also rich in mucilage and pectin, which are suitable as thickening agent in the food industry.

*Opuntias* can also serve as biological fences if planted around 30 cm apart. Not only they provide security, but also flowers that attract bees and fruit (Inglese et al. 2018).

### **2.1.6. Medicinal benefits**

It was already at the times of the ancient Mesoamerican civilisations that the Cactus cladodes, fruits, seeds and flowers were widely used to treat wounds and illnesses. Native civilisations have been consuming the cacti plants for over 12,000 years for its nutritional and healing qualities (Inglese et al. 2018).

Many studies have revealed that cactus fruits and cladodes have high concentrations of necessary nutrients, minerals, vitamins, and antioxidants. It is also important to mention the great source of phytochemicals in the cactus plants (El-Mostafa et al. 2014).

#### **2.1.6.1. Antioxidant properties**

Prickly pear is known for being rich in  $\gamma$ -tocopherol.  $\gamma$ -tocopherol is a compound that is effective in suppressing prostate cancer cell growth, it reduces oxidative DNA damage and neutralizes peroxynitrite with its nitrating and oxidizing effect. The higher levels of vitamin E (tocopherols) present in the *Opuntia* oils contribute to the effect of stability against oxidation. Antioxidants are molecules that suppress oxidation. Because of their ability to prevent the pathogenic mechanisms linked to oxidative stress in the body, they have gained increased attention. To investigate these properties, different *in vivo* and *in vitro* methods are used (Chbani et al. 2023).

A study investigating the phytochemical composition and oxidative stability of *Opuntia ficus-indica* seed oil has reported high concentration of tocopherols (946 mg/kg) in the

cold pressed seed oil from Morocco. This amount included 90.5 % of  $\gamma$ -tocopherol. This result was significantly higher than solvent extracted seed oil from Tunisia (447 mg/kg) and Germany (403 mg/kg). Cactus seed oil has a total tocopherol concentration that is very close to argan oil (850 mg/kg), but much higher than the tocopherol content in olive oil (220 mg/kg) or soybean (650 mg/kg) (Gharby et al. 2015).

As a result of prickly pear oil composition that includes not only tocopherols, but also carotenoids and polyphenols the oil gets antioxidant properties (El-Mostafa et al. 2014; Chbani et al. 2023).

#### **2.1.6.2. Antimicrobial properties**

Prickly pear seed oil has strong antibacterial properties. A study conducted by Ramírez-Moreno et al. (2017) has demonstrated that the seed oils extracted from Mexican varieties (*Opuntia albicarpa* and *Opuntia ficus-indica*) have high antimicrobial activity against gram-positive and gram-negative bacteria. Their antimicrobial activity was comparable to the typical antimicrobial drugs such as ampicillin, streptomycin, and sulfamethoxazole/trimethoprim.

Another study conducted by Khémiri & Bitri (2019) confirmed antimicrobial activity of cold pressed *Opuntia ficus-indica* seed oil against *Enterobacter cloacae* as well as antifungal effects on *Candida parapsilosis* and cutaneous molds such as *Penicillium*, *Aspergillus* and *Fusarium*. Some other studies also confirmed the seed oils positive effect against *Escherichia coli*.

It is also important to mention the wound healing effect and the preventive protective function against infections and shortening the reepithelisation phase (Chbani et al. 2023).

#### **2.1.6.3. Anti-inflammatory activity**

Inflammation is a defence mechanism of the immune system against some irritant that's in the body. There are two types of inflammation – acute and chronic. While acute inflammation can be caused by microbial infection or tissue damage caused by some injury and lasts between 2-6 weeks, chronic inflammation is long-term, and the duration can be even for several years. It can be caused by inability of the immune system to eradicate infectious organisms, by an autoimmune disorder, repeated episodes of acute inflammations or the oxidative stress caused by inflammatory inducers such as free

radical molecules for example. Some typical chronic inflammation diseases are allergies, diabetes, cardiovascular diseases, arthritis, and chronic obstructive pulmonary disease (Pahwa et al. 2023).

Several studies already confirmed the anti-inflammatory properties of *Opuntia*. Based on the research done by Koshak et al. (2020), the OFI seed oil exhibited anti-inflammatory properties on rat models with paw oedema. These properties are a result of the unsaturated fatty acids contained in the oil, such as the omega-9 fatty acid - oleic acid, and  $\beta$ -sitosterol, which help reduce the production of inflammatory mediators, such as prostaglandins.

Furthermore, nicotiflorin, a compound present in OFI cladodes, has neuroprotective and anti-inflammatory properties as well. Another compound found also in the OFI seed oil, omega-3 linolenic acid is widely recognized for its health benefits, namely in cardiovascular diseases, inflammatory conditions, autoimmune disorders and diabetes (El-Mostafa et al. 2014).

#### **2.1.6.4. Cholesterol-reducing properties**

From the plants of the Mediterranean, cactus pear presents effects that reduce blood sugar and cholesterol levels (Ennouri et al. 2007; Chbani et al. 2023). A study conducted by Wolfram et al. (2002) conducted a pilot study on 24 non-diabetic, healthy weight males affected either by hypercholesterolemia or hyperlipidemia. Hyperlipidemia describes high lipid levels in the body, namely low-density lipoprotein (LDL) cholesterol or triglycerides. Hypercholesterolemia is a specific type of hyperlipidemia – which is characterized by high levels of LDL or low levels of HDL cholesterol (high-density lipoprotein) (Hersh 2022).

The results of the research revealed that the daily consumption of 250 g of *Opuntia robusta* fruits resulted in an anti-hyperlipidemic and cholesterol-reducing action, which could be explained by the pectin content of fruits. The regular consumption also exhibited hypoglycaemic effect, possibly explained by the promotion of cellular sensitivity to insulin by the fruit (Wolfram et al. 2002; Inglese et al. 2018).

Another study, by Ennouri et al. (2007) demonstrated that supplementation of 25 g of *Opuntia ficus-indica* seed oil in rat diets resulted in reduction of LDL and serum glucose levels. The findings emphasize on the value of prickly pear from the nutritional aspect.

### 2.1.6.5. Hangover-alleviating action

Studies have demonstrated that symptoms of alcohol hangover (e.g. nausea, dry mouth) could be alleviated by *Opuntia ficus-indica* plant extracts. Moreover, its plant extracts potentially exhibit preventive effects against alcohol addiction (El-Mostafa et al. 2014; Inglese et al. 2018).

### 2.1.6.6. Dermatologic properties

One of the reasons behind the value of Opuntia seed oil, is its richness in unsaturated fatty acids. The seed oils obtained from prickly pear are very high in linoleic and oleic acid, as well as saturated fatty acids - palmitic and stearic acid. These compounds exhibit positive effects on the skin, such as on its elasticity, cell metabolism and skin structure restoration. Furthermore, it has skin anti-aging properties and prevents wrinkles (Taamallah et al. 2021).

## 2.2. Bioactive compounds

### 2.2.1. Linoleic acid

Linoleic acid is a polyunsaturated fatty acid (PUFA), globally known as an omega-6 fatty acid. According to IUPAC standards of nomenclature (International Union of Pure and Applied Chemistry) this compound is also known as (9Z, 12Z)-octadeca-9,12-dienoic acid. As the name indicates, the two double bonds in this compound are on positions 9 and 12 with Z stereochemistry, which denotes that both substituents attached to the carbons with double bonds are placed on the same side of the compound.

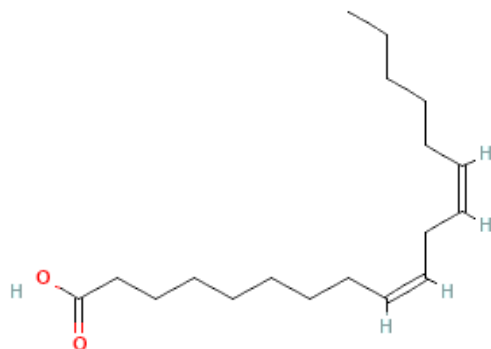

**Figure 1:** Chemical structure of linoleic acid

Source: PubChem 2024a

Molecular formula for linoleic acid is  $C_{18}H_{32}O_2$ . Molecular weight is 280.4 g/mol. It is a colourless or pale-yellow coloured liquid. Commonly it is found in plant oils, such as safflower oil, sunflower or corn oil. Linoleic acid is an essential omega-6 fatty acid as it cannot be produced by humans (PubChem 2024a). It is important for maintaining physiological functions, such as synthesis of phospholipids and it reduces the effect of LDL cholesterol (ChemicalBook 2023a). Moreover, it has a role in improving cardiovascular health, controlling blood pressure and improves insulin sensitivity (Farvid et al. 2014). It is also very important for the skin, as it has a fortifying effect on the skin barrier, hydrates the skin and has anti-inflammatory properties, which helps with acne-prone skin (Bell & Nouril 2024).

### 2.2.2. Oleic acid

Oleic acid, is a monounsaturated omega-9 fatty acid (MUFA), also known as (9Z)-9-Octadecenoic acid (IUPAC). The double bond is located at the 9<sup>th</sup> carbon and has Z stereochemistry. Its molecular formula is  $C_{18}H_{34}O_2$  and molecular weight 282.5 g/mol. Similarly to linoleic acid, it is also a colourless to light yellow liquid with mild odour.

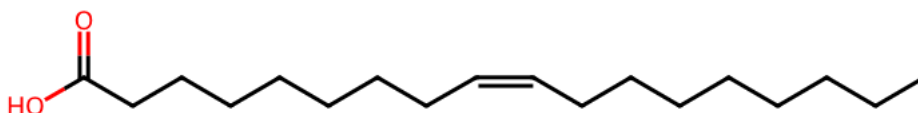

**Figure 2:** Chemical structure of oleic acid

Source: ChemSpider 2024a

This fatty acid is most globally distributed and the most present in nature, it occurs in animal and vegetable oils. Highly abundant in olive oil and almond oil (80 %) and present in fruit, its use is broad – as food additive, in soaps, lotions and emulsifying component in pharmaceuticals. It is widely known as a skin penetrant; higher concentrations are known to reduce blood levels and cholesterol (ChemicalBook 2023b; PubChem 2024b). In the diets it is also connected with lowering the risk of coronary heart disease (Lopez et al. 2010).

### 2.2.3. Palmitoleic acid

Palmitoleic acid, or (9Z)-9-Hexadecenoic acid (IUPAC), is a clear liquid omega-7 monounsaturated fatty acid (MUFA) with the molecular formula  $C_{16}H_{30}O_2$  and molecular weight 254.41 g/mol. The double bond is situated at the 9<sup>th</sup> carbon (ChemicalBook 2023c; ChemSpider 2024b; PubChem 2024c). It is found in marine sources such as fish oil and plants, such as macadamia nuts and buckthorn seed oil (Hernandez 2016). Also present in human skin, it is important to mention that its concentration decreases with age (Weimann et al. 2018).

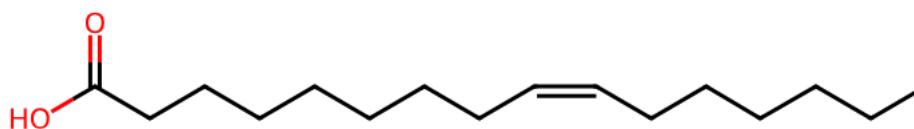

**Figure 3:** Chemical structure of palmitoleic acid

Source: ChemSpider 2024b

It contributes to lowering protein oxidation and increases insulin sensitivity by reducing inflammation (ChemicalBook 2023c). Other studies also reported its association with reducing the risk of diabetes (Hernandez 2016). It is also useful in the treatment of skin hyperpigmentation and wound healing (Weimann et al. 2018). Furthermore, the study by Koh et al. (2023) concluded that oral intake of palmitoleic acid improves skin barrier function in aging adults.

### 2.2.4. Stearic acid

Stearic acid or Octadecanoic acid (IUPAC) is a saturated fatty acid (SFA) composed of a straight chain of 18 carbons with single bonds. Its molecular formula is  $C_{18}H_{36}O_2$  and molecular weight 284.5 g/mol.

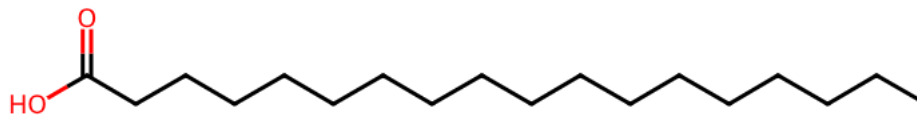

**Figure 4:** Chemical structure of stearic acid

Source: ChemSpider 2024c

It is a white waxy solid found in animal and plant fats, notably abundant component in cocoa, coconut and shea butter (PubChem 2024d). Apart of the diet, it is useful in hardening soaps, candles and cosmetics. Stearic acid was proven to reduce inflammation, eczema symptoms and moisture retention in the skin. However, it is not supposed to be used on its own, as it could potentially cause irritation (Rees & Gathers 2023). The study of Senyilmaz-Tiebe et al. (2018) concluded that stearic acid reduces cancer and cardiovascular risk.

### 2.2.5. Behenic acid

Behenic acid, by IUPAC named Docosanoic acid, is a saturated fatty acid (SFA) with a long chain containing 22 carbons. Its molecular formula is  $C_{22}H_{44}O_2$ , molecular weight is 340.6 g/mol. It is a major component of ben oil, which is obtained from the moringa tree seeds. It is a white crystalline powder (ChemicalBook 2023d; PubChem 2024e).

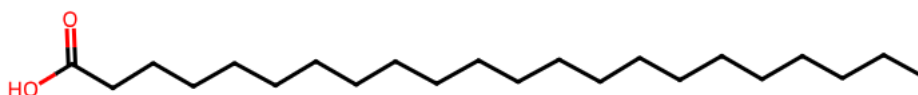

**Figure 5:** Chemical structure of behenic acid

Source: ChemSpider 2024d

Behenic acid is known in skincare formulas, as it helps with dry and sensitive skin, as it improves skin-hydratation and has soothing properties (L'Oréal Paris n.d.; Banov et al. 2014).

## **2.3. Chromatography**

Chromatography is a widely used separation technique that was firstly described by the Russian botanist Mikhail Tsvet in 1901, who used this technique to separate plant pigments (Leníček 2014). This analytical method that enables separation and qualitative and quantitative analysis of samples that are either volatile or soluble in corresponding solvents. The process of chromatography is based on two phases – stationary (stable phase), in which the components can be solid or liquid and mobile (moving phase), which is composed of a liquid or gaseous component. (Meyer 2005; Coskun 2016).

The concept of separation of the various molecules within a mixture depends on some factors, such as molecular adsorption, affinity, or even different molecular weights. These factors affect how long the molecules will stay in the stationary phase and how fast the molecules will move into the mobile phase and passing further within the system (Coskun 2016). When the separated analytes pass through the system quickly, they have higher affinity to the mobile phase. On the contrary, analytes that prefer the stationary phase, pass very slowly through the system. (Leníček 2014).

The time that the separated compound spent in the stationary and mobile phase is collected, and it refers to the retention time ( $R_t$ ) (Bushra 2018).

There are three main elements within the chromatography system – the solid or liquid component of the stationary phase, the liquid or gaseous component of mobile phase, the separated components (analytes) (Coskun 2016).

There are many different types of chromatography techniques. Based on the physical state of the mobile phase, it is necessary to distinguish between two types - liquid chromatography (mobile phase is liquid) and gas chromatography (mobile phase is gas) (Leníček 2014).

### **2.3.1. Gas chromatography**

Gas chromatography (GC) is a technique that enables the separation and analysis of volatile compounds. In the case of analytes that are not volatile, derivatisation is necessary, for example, in case of fatty acids, it is needed to convert them to esters to turn them into sufficiently volatile analytes (Lundanes et al. 2013). The modern GC was firstly introduced in the year 1952 by James & Martin. GC is nowadays widely used as it is a



fast analytical method with very high sensitivity. In this method, the analytes get separated after the sample is dissolved in a solvent and vaporized. The mobile phase is composed of a chemically inert gaseous element, usually helium or nitrogen is used (Kaur et al. 2018).

There are two types of GC – gas-solid chromatography (GSC) and gas-liquid chromatography (GLC). These two types are distinguished based on the principle of separation and their stationary phase. GSC is characterised by a solid adsorbent, the separation occurs when the analytes differ in the adsorption to a solid stationary phase. Whereas GLC, also known as partition chromatography, is characterised by a liquid on an inert support, the separation takes place when distribution of analytes between stationary and mobile phases differs (Lundanes et al. 2013; Kaur et al. 2018).

In general, six main components constitute all chromatographs (GSC or GLC): Sample injection system, carrier gas, separation column, column oven, detectors, amplification, and recorder system (Kaur et al. 2018).

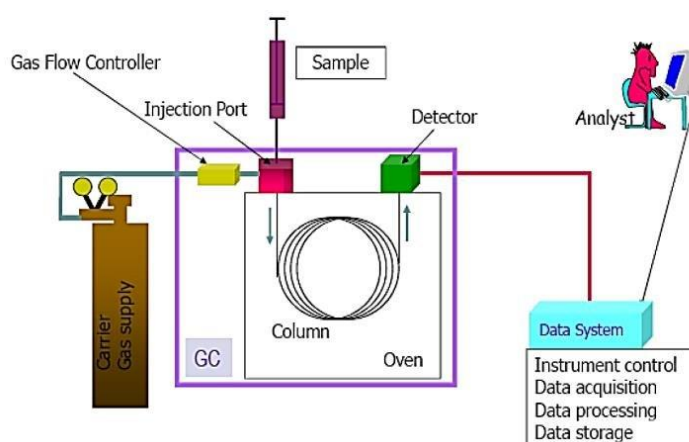

**Figure 6:** Schematic Diagram of Gas Chromatography

Source: Obeidat 2021

The whole GC process starts with the injection of the sample into the column. Afterwards, the sample flows through the column propelled by the inert gas which results in the separation of the sample components. Subsequently, the peaks recorded in the chromatogram are the result of the components exiting the column. The separation and

elution time of each component differ; thus, the retention times of the components vary accordingly (Kaur et al. 2018).

## **2.4. Mass spectrometry**

Mass spectrometry (MS) is a widely used technique that quantifies, analyses, and detects different compounds.

This instrumental method separates charged molecules in the gas phase. By assessing mass-to-charge ratio ( $m/z$ ), where  $m$  denotes the molecular weight and  $z$  indicates the number of charges present in the analysed molecule, structural information is provided (Awad et al. 2015; Urban 2016).

Prior to the successful utilisation of the MS technique, it is important to prepare samples before their ionisation in the mass spectrometer. By utilising gas or liquid chromatography, the samples are either in gaseous or liquid form.

After the conversion of the molecules into ions, the ions get to interfere with the electric and magnetic fields in the mass spectrometer. For this to occur, three indispensable components are necessary:

- Ion source – responsible for the ionisation of the sample
- Mass analyser – responsible for sorting of ions in space or time based on the mass-to-charge ratio
- Detector – responsible for the measurement of separated ions

Subsequently, electric signals that are produced by the detector enable further processing to generate a chart known as mass spectra (Urban 2016; Garg & Zubair 2023).

In total, there are five testing procedures running in order to analyse the sample:

### **1. Ionisation**

During this process the atoms of the molecule are ionised by losing an electron to become an ion with a positive charge, known as cation. In GC/MS technique electron ionisation is the most prevailing type of ionisation. In this technique the development of molecule ions and fragments is due to the high-energy electrons that “bombard” the sample molecules.

## 2. Acceleration

To achieve the exact same kinetic energy, the positive ions will traverse through the mass spectrometer and accelerate into the ion beam. This process enables the mass spectrometer to sort the ions on the basis of mass-to-charge ratio.

## 3. Deflection

The magnetic field of mass spectrometry enables the deflection of cations based on their mass and charge. Higher deflection is a result of lower mass or higher ion charge. Thanks to the deflection, the mass spectrometer is able to determine the mass-to-charge ratio.

## 4. Detection

Detection is the process of quantifying, sorting and removing ions. While positive ions get detected, the ions with neutral charge are removed by the vacuum.

## 5. Vacuum

The vacuum effect ensures that ions will not clash with each other. It allows the mass spectrometer to operate at a lower pressure (Garg & Zubair 2023).

## **2.5. Extraction methods**

Oil yield and the quality of the oil is affected by multiple factors, such as the origin, ripeness, harvest period, but most importantly by the cultivar and extraction technique. Various extraction methods can be used for oil extraction from prickly pear seeds. The conventional extraction methods include Soxhlet extraction, maceration, or cold pressing. There are also some alternative innovational methods, such as supercritical fluid extraction, microwave-assisted extraction or ultrasound extraction (Al-Naqeb et al. 2021; Chbani et al. 2023).

It is important to take into consideration the purpose of extraction, nature of the study and sample amount and characteristics to determine the most suitable extraction method. The most commonly used methods in the scientific studies were solvent based extraction techniques (Soxhlet extraction, maceration, mechanical extraction) which result in higher

yields. On the other hand, the non-solvent extractions are safer, more environmentally friendly and less time-consuming (Thanonkaew et al. 2012; Masmoudi et al. 2021).

### 2.5.1. Soxhlet extraction

The inventor behind the Soxhlet extraction was a German chemist, Franz Ritter von Soxhlet, who came up with this extraction technique in 1879. The original use of this apparatus was to determine and extract fats from milk (Douglas 2019).

The figure below depicts the parts of a classic Soxhlet apparatus. Once the solid sample is in powder form, it is placed in a porous thimble that is placed inside the extractor. The solvent is poured in the distillation flask and subsequently heated. As the temperature of the solvent rises, vapour starts to form and travels through the tube sidearm. When the vapours get in contact with the condenser, the solvent starts dripping into the sample and dissolves the analytes. Once the siphon tube is filled with the liquid solute, the solute (solvent with extracted substances) is aspirated by the siphon mechanism back to the distillation flask. This whole cycle is repeated multiple times and as the solvent boils and re-evaporates, the concentration of the solutes increases until the extraction procedure is complete (Luque de Castro & Priego-Capote 2010; Douglas 2019).

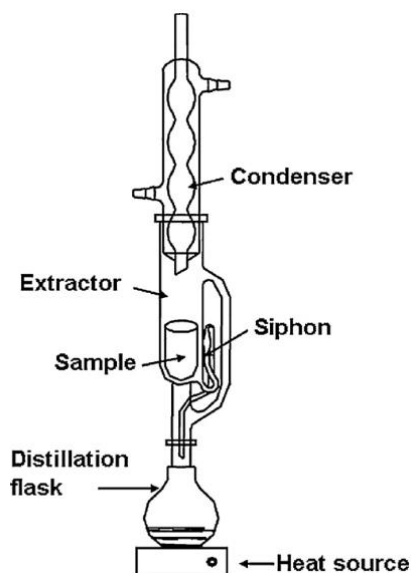

**Figure 7:** Conventional Soxhlet apparatus

Source: Luque de Castro & Priego-Capote 2010

This widely recognised extraction technique is simple to use and does not necessarily require any training beforehand. There is no necessity for filtration, the system maintains high temperature throughout the process as the applied heat to the flask reaches the extraction cavity. Other benefits of this extraction technique include the higher extraction yield compared to other latest alternatives, such as microwave-assisted extraction or extraction by supercritical fluid, or possibility of running multiple extractions in parallel thanks to the low-cost basic material needed.

However, this method has some shortcomings as well. The main issue is the lengthy solid sample preparation prior to the extraction as well as the amount of wasted solvent (extractant), which not only is expensive, but it also leads to environmental problems. Additionally, as this process takes several hours under high temperatures, there is a potential decomposition of heat-sensitive target compounds (Luque de Castro & Priego-Capote 2010).

### **2.5.2. Cold-press extraction**

The drawback solvent-based extraction is the additional purification process which is the subsequent removal of the solvent from the obtained oil. A solvent-based extraction would result in lower quality oil, therefore marketed at a lower price. For commercial purposes, the market prefers extraction by mechanical means. Overall, consumers lean towards natural pure virgin oils, and are willing to pay higher prices for them. This trend can already be observed in olive and argan oils (Hänke et al. 2018).

Thus, cold pressing is the usual extraction method for available commercial *Opuntia* seed oil. After the seeds are obtained through mechanical sieving, the oil is obtained by pressing the seeds via a hydraulic press. The whole process can take 3-4 days. The cold pressed prickly pear oil is one of the most expensive oils in the world, as about half a tonne of fruit is needed to obtain a yield of one litre of OFI oil (Chakir 2011; Ciriminna et al. 2017).

It is important to mention that in order to maintain the quality of the oil and high concentration of antioxidants and unsaturated fatty acids, the oil mill must run in a way to limit the contamination of the produced oil and its exposure to air. This would necessitate advanced technical equipment, skilled personnel, and appropriate logistics (Hänke et al. 2018).

## 2.6. Scientific studies on this issue

Many scientific studies already conducted chemical analyses of *Opuntia* seed oils by GC/MS in order to detect and identify the chemical composition of the oil and investigate its properties. Below are some selected studies that were chosen for comparison with this thesis.

Masmoudi et al. (2021) conducted a study investigating the physico-chemical and antioxidant properties of oils and by-products obtained by cold-press extraction of Tunisian *Opuntia* cultivars. The study was conducted on mature *Opuntia* fruits, namely on spiny and thornless OFI with yellow-orange and pink-purple cultivars as well as on red-purple *Opuntia stricta*. After the seeds were extracted and dried, the seed oil was obtained by cold pressing with the use of a screw press. The composition of the oil and detection of fatty acids was done by GC/MS after derivatisation to methyl esters by boron trifluoride/methanol reagent. Table 2, retrieved from the study, illustrates the composition of fatty acids present in analysed *Opuntia* seed oils. The results revealed three dominating fatty acids – the major compound, linoleic acid was the most abundant (67.6 % to 70.3 %), oleic acid concentrations were between 15.36 % - 19.96 % and palmitic acid (4.7 % - 6.04 %) (Masmoudi et al. 2021).

**Table 2:** Fatty acid composition of *Opuntia* seed oils from Tunisia

Fatty acid	IS	ITp	ITy	OS
Palmitic C16:0	6.04 ± 0.13 <sup>a</sup>	5.04 ± 0.08 <sup>b</sup>	4.70 ± 0.01 <sup>c</sup>	4.72 ± 0.01 <sup>c</sup>
Palmitoleic C16 :1	3.15 ± 0.08 <sup>a</sup>	3.06 ± 0.03 <sup>b</sup>	2.86 ± 0.02 <sup>d</sup>	2.62 ± 0.02 <sup>c</sup>
Stearic C18:0	2.78 ± 0.03 <sup>a</sup>	1.67 ± 0.04 <sup>b</sup>	2.24 ± 0.03 <sup>d</sup>	1.96 ± 0.02 <sup>c</sup>
Oleic C18:1	19.96 ± 0.13 <sup>a</sup>	15.36 ± 0.09 <sup>b</sup>	19.54 ± 0.04 <sup>d</sup>	17.42 ± 0.02 <sup>c</sup>
Linoleic C18:2	67.60 ± 0.16 <sup>a</sup>	70.30 ± 0.06 <sup>b</sup>	68.06 ± 0.06 <sup>c</sup>	67.68 ± 0.14 <sup>a</sup>
γ- Linolenic C18 :3	1.31 ± 0.05 <sup>a</sup>	1.98 ± 0.02 <sup>b</sup>	1.19 ± 0.04 <sup>c</sup>	1.50 ± 0.04 <sup>d</sup>
Eicosenoic C20:1	0.58 ± 0.02 <sup>a</sup>	1.28 ± 0.04 <sup>b</sup>	0.82 ± 0.03 <sup>c</sup>	0.66 ± 0.03 <sup>d</sup>
Docosadienoic C22:2	0.41 ± 0.02 <sup>a</sup>	0.96 ± 0.04 <sup>b</sup>	0.60 ± 0.05 <sup>c</sup>	1.31 ± 0.01 <sup>d</sup>
Eicosapentanoic C20:5	ND	1.00 ± 0.03 <sup>a</sup>	ND	0.92 ± 0.01 <sup>b</sup>
Nervonic C24:1	ND	ND	ND	1.74 ± 0.02
MUFA	23.69 ± 0.23 <sup>a</sup>	19.70 ± 0.16 <sup>b</sup>	23.22 ± 0.09 <sup>c</sup>	22.44 ± 0.09 <sup>d</sup>
PUFA	69.32 ± 0.23 <sup>a</sup>	74.24 ± 0.15 <sup>b</sup>	69.85 ± 0.15 <sup>c</sup>	71.40 ± 0.2 <sup>d</sup>
UFA/SFA	10.54 ± 0.19 <sup>a</sup>	14.00 ± 0.28 <sup>bd</sup>	13.4 ± 0.06 <sup>c</sup>	14.05 ± 0.03 <sup>b</sup>

ISy : *Opuntia ficus indica* « spiny » (yellow-orange) ; ITp : *Opuntia ficus indica* « thornless » (pink-purple) ; ITy : *Opuntia ficus indica* « thornless » (yellow-orange) ; OS : *Opuntia stricta*.

ND : not detected ; UFA/SFA : unsaturated/saturated fatty acids ratio ; MUFA : monounsaturated fatty acids ; PUFA : polyunsaturated fatty acids.

Results are expressed as mean values of three determinations ± SD; Means within the same row with different letters are significantly different (p < 0.05).

Source: Masmoudi et al. 2021

The study of Ramírez-Moreno et al. (2017) was focused on determination of antioxidant and antimicrobial properties and fatty acid profile of the cactus pear seed oil obtained from two different varieties of cactus pear found in Mexico – green *Opuntia albicarpa* and red *Opuntia ficus-indica*.

The extraction of the oil was accomplished by mixing the powdered seeds with hexane, ethanol and ethyl acetate. The residue was extracted multiple times until the used solvents became colourless. Subsequently, the extract underwent filtration, further removal of residual solvent was conducted at 50 °C by using BUCHI R-200 rotary evaporator. Potassium hydroxide was used for derivatisation of the oil to obtain methyl esters. The apparatus GC-MS HP-5890 equipped with a Flame Ionisation Detector was used ZB-WAX fused capillary column 60 m x 0.25 mm x 0.25 mm film thickness. Nitrogen was the used carrier gas.

The obtained results confirmed the dominant presence of linoleic acid (C18:2) - 65.4 % and 67.4 %. Myristic (C14:0), palmitoleic (C16:1), hexadecadienoic (C16:2) and margaric fatty acids (C17:0) were also identified, in minimal amounts.

**Table 3:** Percentages of FAMES in crude cactus pear seed oil extracts from Mexico

FAMES	Green cactus pear seed oil extract	Red cactus pear seed oil extract
C14:0	0.078 ± 0.00	0.066 ± 0.01
C16:0	12.327 ± 0.09	12.887 ± 0.02
C16:1	0.429 ± 0.02	0.570 ± 0.01
C16:2	0.073 ± 0.00	0.540 ± 0.00
C17:0	0.060 ± 0.01	0.075 ± 0.00
C18:0	3.436 ± 0.01	3.389 ± 0.07
C18:1	16.215 ± 0.03	17.061 ± 0.01
C18:2	67.448 ± 0.08	65.407 ± 0.01
C18:3	Ni	0.372 ± 0.01
C22:0	Ni	0.160 ± 0.01

Means of 3 replicates ± SE. Ni: not identified.

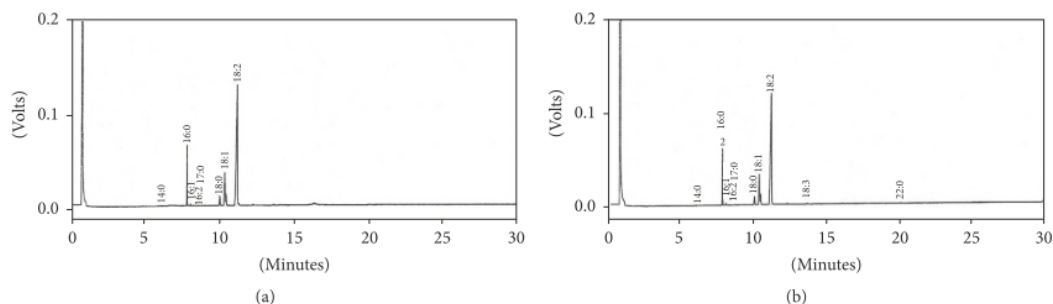

FIGURE 4: Chromatograms of FAMES of cactus pear seed oil extract. (a) Green cactus pear seed oil extract; (b) red cactus pear seed oil extract. In both oils extracts were identified: myristic (C14:0), palmitic (C16:0), palmitoleic (C16:1, *cis*-9), hexadecadienoic (C16:2, *cis*-9, 12), margaric (C17:0), stearic (C18:0), oleic (C18:1, *cis*-9), linoleic (C18:2, *cis*-9, 12), except linolenic (C18:3, *cis*-6, 9, 12), and behenic (C22:0) fatty acids that were identified only in red cactus pear seed.

Source: Ramírez-Moreno et al. 2017

The study conducted by Chougui et al. (2013) focused on oil composition and phenolic profile of *Opuntia ficus-indica* seeds from Algeria. Four varieties of OFI were collected (green, yellow, orange, red). The seed oils were extracted using the Soxhlet extraction method. Fatty acid profile was determined by using a Perichrom TM 2000 gas chromatograph including flame ionisation detector and a fused capillary column of silica (50 cm length and 0.25 internal diameter). The used carrier gas was hydrogen. The identification of fatty acids was done by comparing their retention times with standard mixtures.

**Table 4:** Fatty acids content identified in the OFI seed oil from Algeria

Variety	Oil rate (%)	Fatty acids (%)						Total SFA	Total UFA	UFA/SFA
		Palmitic acid (C16)	Stearic acid (C18)	Oleic acid (C18:1n-9)	Vaccenic acid (C18:1n-7)	Linoleic acid (C18:2n-6)				
Green	8,4	13.1 ± 0.1 <sup>b</sup>	3.5 ± 0.1 <sup>b</sup>	16.3 ± 0.1 <sup>c</sup>	5.3 ± 0.1 <sup>a</sup>	61.8 ± 0.1 <sup>c</sup>	16.6 ± 0.1 <sup>b</sup>	83.5 ± 0.1 <sup>a</sup>	5.0 ± 0.1 <sup>a</sup>	
Yellow	9,3	13.4 ± 0.1 <sup>a</sup>	3.6 ± 0.1 <sup>b</sup>	20.9 ± 0.1 <sup>b</sup>	0.0 ± 0.0 <sup>c</sup>	62.1 ± 0.1 <sup>b</sup>	16.9 ± 0.1 <sup>a</sup>	83.1 ± 0.1 <sup>c</sup>	4.9 ± 0.1 <sup>c</sup>	
Orange	7,7	13.4 ± 0.1 <sup>a</sup>	3.3 ± 0.0 <sup>c</sup>	15.2 ± 0.1 <sup>d</sup>	5.1 ± 0.1 <sup>b</sup>	63.1 ± 0.1 <sup>a</sup>	16.7 ± 0.1 <sup>b</sup>	83.3 ± 0.0 <sup>b</sup>	5.0 ± 0.0 <sup>b</sup>	
Red	7,3	12.7 ± 0.1 <sup>c</sup>	4.2 ± 0.1 <sup>a</sup>	24.3 ± 0.1 <sup>a</sup>	0.0 ± 0.0 <sup>c</sup>	58.7 ± 0.1 <sup>d</sup>	16.9 ± 0.1 <sup>a</sup>	83.1 ± 0.1 <sup>c</sup>	4.9 ± 0.1 <sup>c</sup>	

SFA: saturated fatty acid, UFA: unsaturated fatty acid.

The values having the same letter within the column did not differ significantly from each other according to LSD test at  $p \leq 0.05$ .

Source: Chougui et al. 2013

The results presented above in the Table 4 confirm that linoleic acid was the dominating fatty acid with concentration ranging from 58.7 % to 63.1 % among the cultivars. The following fatty acid is oleic (15.2 % to 24.3 %), palmitic (12.7 % to 13.4 %) and stearic (3.3 % to 4.2 %). Vaccenic acid was absent in yellow and red varieties. The study confirmed that the presented results were similar to other studies. Chougui et al. (2013) also concluded that the selected varieties contained a significant quantity of unsaturated fatty acids which are beneficial for health. Moreover, the varieties with the highest phenolics, tannins and flavonoid contents were presenting the highest antioxidant activity.



### **3. Aims of the Thesis**

#### **3.1. Main objective**

The aim of the thesis is to compare the chemical composition of extracted seed oils from *Opuntia* of different geographical regions with commercially available *Opuntia* seed oils.

#### **3.2. Specific objectives**

1. Literature review focused on the use, properties, and healing effects of the cactus *Opuntia* spp. and its oil.
2. Extraction of oil from *Opuntia* of differing origins, chemical (GC/MS) analysis of extracted oil samples and commercially available *Opuntia* seed oils, and subsequent comparison of results among differing samples with literature data.

## **4. Methods and materials**

### **4.1. Samples**

The analysis was conducted on two samples of *Opuntia ficus-indica* seeds that were extracted from OFI fruit of Colombian and Spanish origin and two samples of commercially available Opuntia seed oil, purchased from the Czech Republic and France. The purchased oils were extracted from Opuntia of different origins – Madagascar and Tunisia.

Thus, in total, the chemical analysis was carried out on 4 different samples:

- Sample 1 – Purchased organic OFI Seed oil 10 ml (brand: Kvitok, price: 19.90 EUR, origin: Madagascar)
- Sample 2 – Purchased OFI Seed oil 30 ml (brand: Aroma-Zone, price: 29.95 EUR, origin: Tunisia)
- Sample 3 – OFI seeds extracted from its fruits (purchased from Czech e-shop Rohlik.cz, price per piece of fruit: 16.40 CZK = about 0.65 EUR, origin: Colombia)
- Sample 4 – OFI seed extracted from its fruits (hand-picked, origin: Menorca, Spain)

#### **4.1.1. Commercially available OFI seed oil**

The OFI seed oil bought from the Czech shop BiOOO was purchased in February 2024. The brand of the oil, Kvitok, is of Slovak origin. The expiration date of the oil is in May 2024. The country of origin of the *Opuntia ficus-indica* is Madagascar. The product was labelled as organic, 100 % natural oil, cold-pressed and unrefined. In addition, there was the Cruelty-free certificate. The price of 10 ml of this oil at the time of purchase was 555 CZK, the Slovak manufacturer sells 10 ml for 19.90 EUR, which makes the price per litre roughly 1990 EUR (BiOOO 2024; Kvitok 2024).



**Figure 8:** Sample 1

Source: BiOOO 2024

The OFI seed oil bought from France was purchased in July 2023 from the company Aroma-Zone. The label indicated the production date November 2022 and best-by date November 2024. The country of origin for this oil was Tunisia. The product was labelled as organic, 100 % pure and natural cold-pressed virgin oil and additionally it carried Ecocert Cosmos certification. The price of 30 ml of this oil is 29.95 EUR, the price per litre amounts to 998.33 EUR (Aroma-Zone 2024).



**Figure 9:** Sample 2

Source: Aroma-Zone 2024

#### **4.1.2. Plant material**

The study was carried out on *Opuntia ficus-indica* collected from two different geographical regions. The first bunch of prickly pear fruit originating from Colombia, was bought online via the Czech e-shop Rohlik.cz. Consequently, the second bunch of prickly pear fruit were hand-picked by the end of January 2024 in Menorca, Spain.



**Figure 10:** Sample 3

Source: Author of the thesis



**Figure 11:** Sample 4

Source: Author of the thesis

#### 4.2. Fruit preparation and seed extraction

The fruits were firstly washed and brushed in order to get rid of impurities and the tiny spikes – glochids. The fruits were then hand-peeled and cut in half. For the prickly pears originating from Menorca, the seeds were separated by hand, later separated from the pulp by a strainer. Whereas, for the fruits originating from Colombia the fruits were mixed and seeds were separated from the juice with the aid of a strainer. The seeds were washed abundantly with water, as the seed was coated in the pulp. After the seeds were air-dried for 48 hours, they were reduced to powder with the aid of a grinder available in the laboratory (Retsch Grindomix GM 100, Germany) with 10000 rmp speed.



**Figure 12:** Extraction and preparation of OFI seeds from Colombia and Spain

Source: Author of the thesis

### 4.3. Oil extraction and GC/MS analysis

#### 4.3.1. Oil extraction

For the fat (triacylglycerides (TAGs)) extraction process from the grounded OFI seeds, an automatic solvent extractor (Velp Scientifica SER 158 Series Automatic Solvent Extractor, Italy) with Randall method was used. Firstly, the grounded seed samples (8.8 g) were weighted and placed in a porous cellulose extraction thimble. The thimble containing the dry sample was positioned in a glass extraction cup that contained 100 ml of the solvent n-Hexane and subsequently placed in the automatic extractor. The method of total fat in oily seeds and nuts was used (reference code AOAC 2003.06). This method included the following parameters: 60 minutes of immersion time, 10 minutes of removing time, 50 minutes of washing time, 30 minutes of recovery time and 4 minutes of cooling time. Therefore, after the duration of 2 hours and 34 minutes of the whole extraction process, oil – scientifically called triacylglycerides (TAGs) were obtained. To enable the solvent to evaporate from the oil, the product was kept for a day at a room temperature.



**Figure 13:** Extracted oil

(from left to right: sample 3,4)

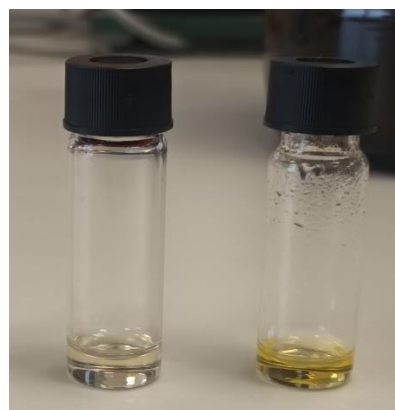

**Figure 14:** Purchased oil

(from left to right: sample 1,2)

#### 4.3.2. Transesterification

To analyse the oils by GC, it is necessary to derivatize TAGs by transesterification to obtain fatty acid methyl esters that are sufficiently volatile and are able to be eluted at acceptable temperatures without causing thermal decomposition (Fisk et al. 2014).

Firstly, all the four oil samples were heated at a temperature of 50 °C. After heating, 100 mg of each sample were placed inside vials and were mixed with 4 ml of sodium methoxide and 1 ml of toluene. Subsequently, after the period of 15 minutes, 5 ml of aqueous acetic acid (5 %) was added followed by 8 ml of hexane. Upon thoroughly shaking the mixture, it was left to separate. Once it was possible to clearly distinguish between the two layers in all the samples, the upper clear layer (rich in methyl esters) was carefully transferred into small vials (Hammond 2003).



**Figure 15:** Oil samples during transesterification

(from left to right: sample 3, 4, 1, 2)

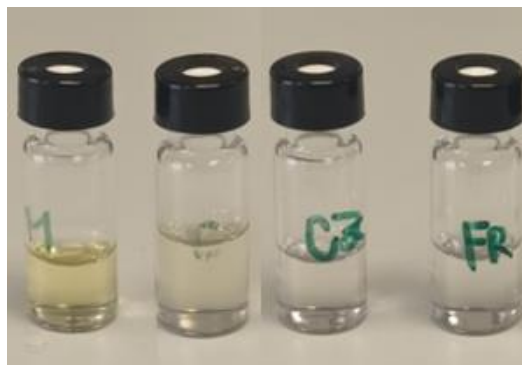

**Figure 16:** Oil samples ready for GC/MS analysis

(from left to right: sample 3, 4, 1, 2)

#### **4.3.3. GC/MS analysis of Fatty Acids**

The extracted samples were transferred to the GC/MS injector. The injections were carried out by an autosampler with the injection volume of 1  $\mu$ l. To avoid contaminations between samples and condition the apparatus, a blank measurement was

run at the very beginning. The GC/MS analysis was conducted on Agilent Technologies 5977A Series GC/MSD provided with a HP-5 column of with dimensions of 0.25 mm (internal diameter) x 60 m (length) x 0.25  $\mu$ m (film thickness). The used carrier gas was helium, the initial oven temperature was adjusted to 70 °C, after 2 minutes the temperature was increased at a rate of 10 °C per minute to 280 °C where it was held for 10 min. In order to process the data, MassHunter Workstation Software Qualitative Analysis B.07.00 was used. As a result of electronic integration, peak areas were obtained. Detected compounds were determined by comparing their mass spectra with the National Institute of Standards and Technology Library version 2.2. (NIST).

The GC/MS analysis detected methyl esters found in each sample. Thus, the corresponding fatty acids were determined based on the results obtained.

#### **4.4. Data analysis**

To ensure a higher degree of accuracy, all the measurements were performed in triplicates. Consequently, there were 12 analyses conducted in total. The arithmetic mean was calculated for each dataset to represent the average values from the three measurements.

## 5. Results

The table below represents the detected compounds, their common name, their retention time (RT) and concentration in percentages in each sample. There were 15 identified compounds in total, as shown below. Most compounds were found in sample 1 (purchased oil of brand Kvitok) and sample 4 (oil extracted from Spanish OFI), both with 14 identified compounds. Sample 2 (purchased oil of the brand Aroma-Zone) and sample 3 (oil extracted from Colombian OFI), in both 13 compounds were detected.

Among all the samples, linoleic acid was identified as the most occurring fatty acid, with over 50 % abundance in each sample. Sample 4 and sample 3 contained the most of this compound, with very similar values – 73.30 % of linoleic acid was detected in sample 4, 73.22 % was found in sample 3. Sample 2 contained 65.47 % and sample 1 contained 50.30 % of linoleic acid.

The second compound detected with in a significant quantity was oleic acid. However, this fatty acid was found mainly in sample 1 (29.44 %). In other samples the amount was lower, ranging from 3.50 % - 11.49 %, where the highest proportion was in sample 2 and lowest in sample 3. Sample 4 contained 3.88 % of oleic acid.

In three samples (sample 2, sample 3, sample 4), the second most abundant fatty acid after linoleic acid was palmitoleic acid. 12.06 % detected in sample 2, 14.62 % in sample 3 and 14.27 % in sample 4. The lowest amount was in sample 1 (11.66 %).

A significant proportion of the samples was also covered by stearic acid. The highest concentration (7.46 %) was detected in the purchased oil of Aroma-Zone brand (sample 2). Similar proportions were found in the following samples: purchased oil of the brand Kvitok (sample 1) contained 5.93 % of stearic acid, extracted oil from Colombian prickly pear fruit contained 5.72 % of this fatty acid, followed by 5.11 % in the extracted oil from the Spanish *Opuntia* cultivar.

The following fatty acids were detected in a concentration higher than 0.70 %. Behenic acid was found in sample 1 (0.72 %). In the other samples its concentration ranged from 0.21 % - 0.56 %. Palmitelaidic acid was identified with the highest abundance in sample 3 (0.90 %), sample 4 (0.86 %), sample 2 (0.74 %). Sample 1 contained significantly lower amount (0.21 %).



**Table 5:** Identified fatty acids in Opuntia seed oil samples

RT	Fatty acid	Common name	Concentration (%)			
			Sample 1	Sample 2	Sample 3	Sample 4
16.36	Tetradecanoic acid	Myristic acid	0.08	0.10	0.10	0.12
18.30	Hexadec-9-enoic acid	Palmitelaidic acid	0.21	0.74	0.90	0.86
18.39	Hexadec-11-enoic acid	Lycopodic acid	-	0.06	0.11	0.11
18.52	Hexadecanoic acid	Palmitoleic acid	11.66	12.06	14.62	14.27
19.26	Heptadec-9-enoic acid	Margaroleic acid	0.06	-	-	0.03
19.47	Heptadecanoic acid	Margaric acid	0.08	-	-	-
20.30	Octadeca-9,12-dienoic acid	Linoleic acid	50.30	65.47	73.22	73.30
20.34	Octadec-9-enoic acid	Oleic acid	29.44	11.49	3.50	3.88
20.46	Octadecanoic acid	Stearic acid	5.93	7.46	5.72	5.11
21.99	Eicos-9-enoic acid	Gadelaidic acid	0.07	0.49	0.39	0.63
22.07	Eicos-11-enoic acid	Gondoic acid	0.49	0.38	0.35	0.41
22.21	Eicosanoic acid	Arachidic acid	0.53	0.54	0.38	0.41
23.77	Docosenoic acid	Erucic acid	0.03	0.39	0.27	0.44
23.91	Docosanoic acid	Behenic acid	0.72	0.56	0.21	0.30
25.98	Tetracosanoic acid	Lignoceric acid	0.39	0.28	0.21	0.12

Source: Author of the thesis

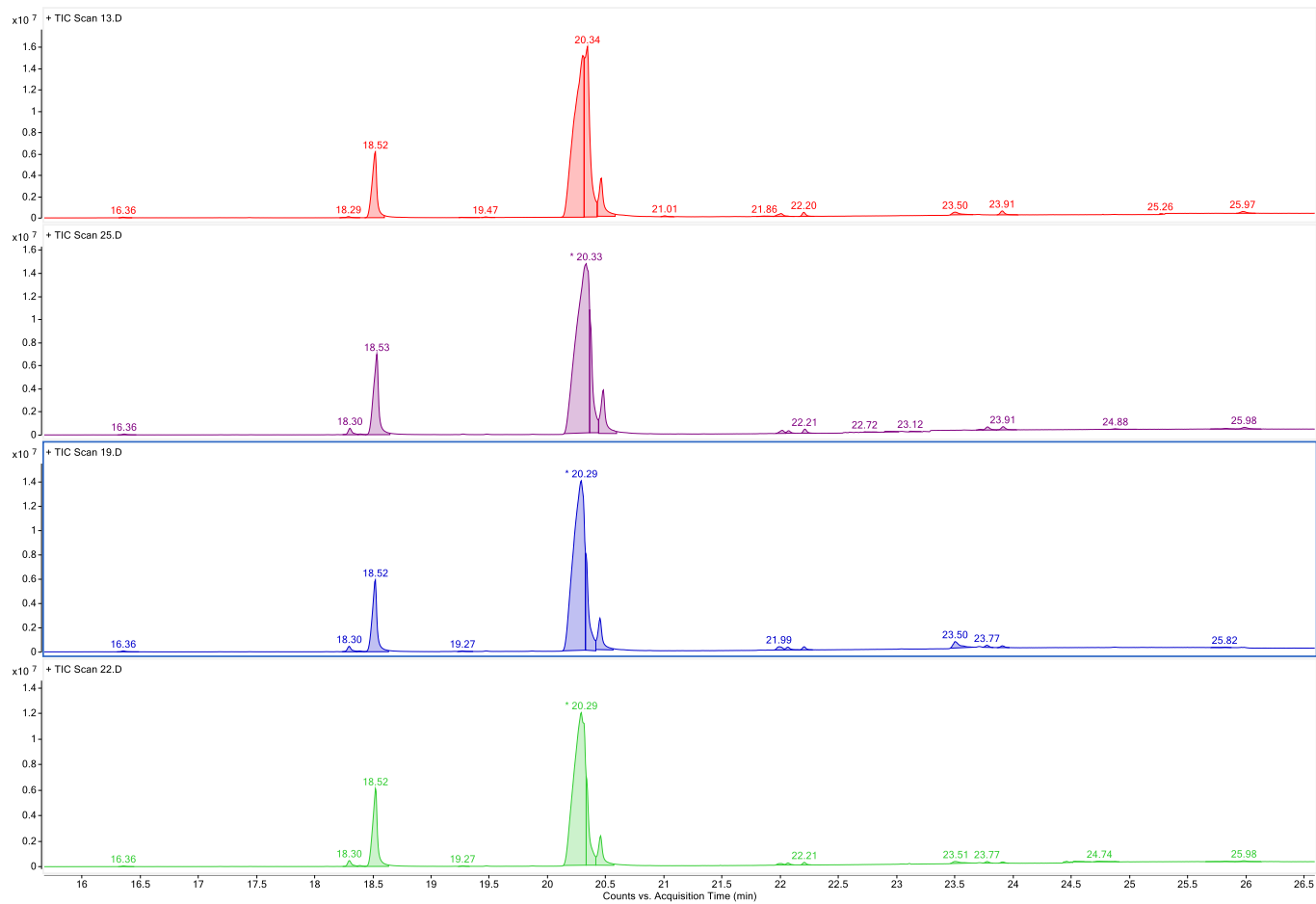

**Figure 17:** Chromatograms of oil samples (from top to bottom: sample 1, sample 2, sample 4, sample 3)

Source: Author of the thesis

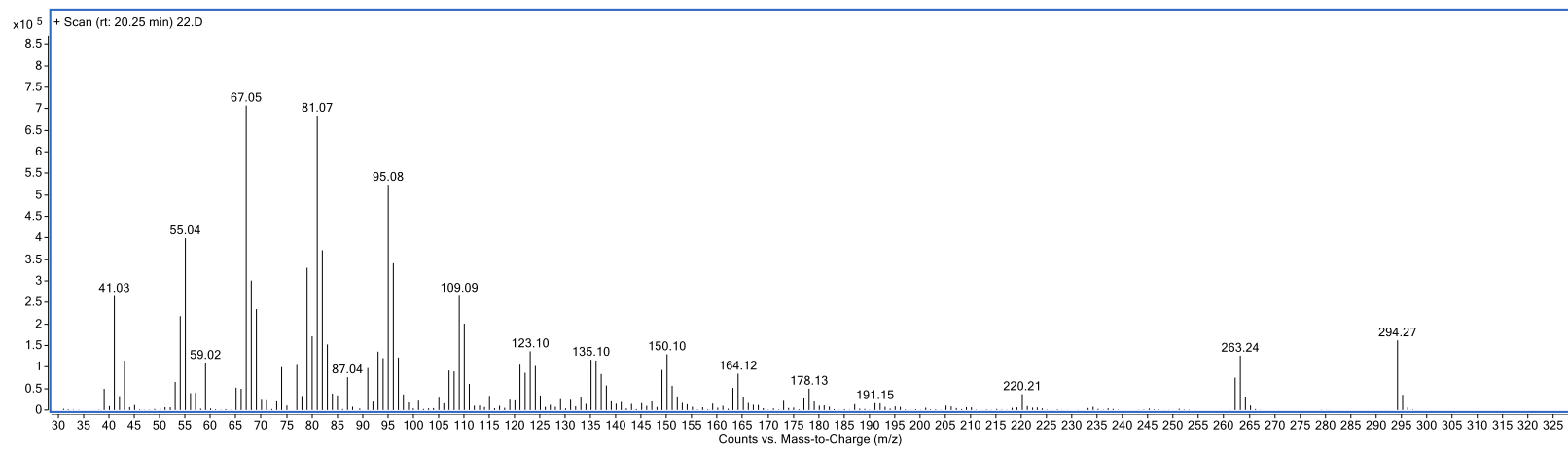

**Figure 18:** Mass spectrum of Octadeca-9,12-dienoic acid, methyl ester

Source: Author of the thesis

## 6. Discussion

The results of this analysis were compared within the samples and with the results obtained from different relevant scientific studies.

Linoleic acid was the major fatty acid found among all the analysed samples. This finding is in accordance with the study conducted by Chougui et al. (2013), Ramírez-Moreno et al. (2017) and Masmoudi et al. (2021). However, our findings demonstrated some higher amounts and even lower amounts compared with the relevant studies. The upper limit of linoleic acid with the abundance above 70 % was found in two samples, specifically in sample 3 seed oil extracted from Colombian OFI (73.22 %) and sample 4 seed oil extracted from Spanish OFI cultivar (73.30 %), both oils were extracted by the Soxhlet method. The highest detected amount of linoleic acid was in the study by Masmoudi et al. (2021), in the Tunisian pink-purple OFI cultivar that contained 70.3 % of this major fatty acid. In this study the oil was extracted by cold-press method. Interestingly, in the case of the comparison of lowest detected amounts, our purchased oil extracted by cold press from Madagascar OFI contained 50.8 % while 58.7 % was the lowest amount in case of the Algerian seed oil from red OFI variety in the study by Chougui et al. (2013). These results could possibly suggest that higher amounts of linoleic acid were found in seed oils extracted by a solvent-based method, which is a bit contraindicatory as usually higher fatty acid content is found in non-solvent extraction, as it eliminates the possibility of impurities.

In the case of stearic acid, Masmoudi et al. (2021) detected the lowest amounts, ranging from 1.67 % to 2.78 %. Our purchased seed oil sample 2 of the same country of origin (Tunisia) and same extraction technique (cold-pressing) exhibited significantly higher concentration – 7.46 %. The deviation could possibly be a result of differing ripeness of the fruit.

Oleic acid was the second most abundant fatty acid in case of sample 1 (purchased cold-pressed seed oil originating from Madagascar), with the concentration 29.44 %. Other studies also detected oleic acid as the second most common fatty acid, regardless of the extraction method. Chougui et al. (2013) demonstrated the most similar result, with the concentration of 24.3 % in the Algerian OFI seed oil.

In terms of margaric acid, that was present in small concentration only in sample 1 (0.08 %), its presence was also confirmed in the study from Ramírez-Moreno et al. (2017), with very similar amounts ranging from 0.060 % to 0.075 %.

Overall, there were considerable deviations in the concentrations of different fatty acids. As already explained in many studies, the concentration can be influenced by many factors, such as the geographical origin, variety, environmental conditions, ripeness of the fruit at the time of collection, storage conditions, extraction technique or analytical methods.

## 7. Conclusions

Due to its various utilisation and health benefits, *Opuntia* is becoming increasingly valued. The main objective of this thesis was to conduct a chemical analysis of commercially available prickly pear seed oils and extracted seed oils.

The main aspects of this fruit crop were highlighted in this thesis throughout the literature review, to emphasise on the various utilisations, biological activities and agroeconomic importance of this versatile crop.

This study presented timely information about the chemical composition of commercially available *Opuntia* seed oils and extracted seed oils. The results confirmed the presence of the main fatty acids - namely linoleic, oleic, palmitoleic, stearic and behenic acid as well as lower amounts of arachidic and myristic acid in all the samples – purchased cold-pressed samples and extracted seed oil samples by a solvent-based method. Indeed, the concentrations varied when compared with the results of other similar studies, however, the dominating fatty acids were found accordingly.

The oil samples differed in colour, the lightest oil was commercially available on the Czech market, originating from Madagascar, with a very clear yellow visual. The second purchased sample, originating from Tunisia was of a pale-yellow colour. The last two extracted prickly pear oils were of a golden yellow colour.

The findings of this research can be used as a basis for further chemical analyses of *Opuntia* seed oils with different extraction techniques or differing cultivars.

## 8. References

- Al-Naqeb G, Fiori L, Ciolli M, Aprea E. 2021, August 2. Prickly pear seed oil extraction, chemical characterization and potential health benefits. MDPI AG.
- Alshaikhi AI, Alzahrani MY, Hazzazi JS, Kurdi JR, Ramadan MF. 2023. Nutritional aspects, bioactive phytochemicals and biomedical traits of *Opuntia* spp.: current trends and applications. *Journal of Umm Al-Qura University for Applied Sciences* DOI: 10.1007/s43994-023-00101-1. Springer.
- Aroma-Zone. 2024. Huile végétale de Figue de Barbarie BIO - Aroma-Zone. Available from <https://www.aroma-zone.com/info/fiche-technique/huile-vegetale-figue-de-barbarie-bio-aroma-zone> (accessed March 15, 2024).
- Aruwa CE, Amoo SO, Kudanga T. 2018, October 1. *Opuntia* (Cactaceae) plant compounds, biological activities and prospects – A comprehensive review. Elsevier Ltd.
- Awad H, Khamis MM, El-Aneed A. 2015, February 15. Mass spectrometry, review of the basics: Ionization. Bellwether Publishing, Ltd.
- Bakewell-Stone P. 2023. *Opuntia ficus-indica* (prickly pear). Available from <https://www.cabidigitallibrary.org/doi/10.1079/cabicompendium.37714> (accessed October 28, 2023).
- Banov D, Banov F, Bassani AS. 2014. Case Series: The Effectiveness of Fatty Acids from Pracaxi Oil in a Topical Silicone Base for Scar and Wound Therapy. *Dermatology and Therapy* 4:259–269. Springer Healthcare. Available from <https://link.springer.com/article/10.1007/s13555-014-0065-y> (accessed April 1, 2024).
- Bell A, Nouril P. 2024, February 27. What is linoleic acid? An expert guide. Available from <https://www.womenshealthmag.com/uk/beauty/skin/a42306698/what-is-linoleic-acid/> (accessed April 1, 2024).
- BiOOO. 2024. BiOOO.cz - Kvitok Opunciový olej 10 ml. Available from [https://www.biooo.cz/opunciovy\\_olej\\_kvitek-p-19074.html?gad\\_source=1&gclid=EAIaIQobChMIIneryvIushQMV2ZGDBx1Vtw5sEAYYAyABEgLkLfD\\_BwE#popis-produktu](https://www.biooo.cz/opunciovy_olej_kvitek-p-19074.html?gad_source=1&gclid=EAIaIQobChMIIneryvIushQMV2ZGDBx1Vtw5sEAYYAyABEgLkLfD_BwE#popis-produktu) (accessed March 15, 2024).

- Brahmi F et al. 2020. Comparison of chemical composition and biological activities of Algerian seed oils of *Pistacia lentiscus* L., *Opuntia ficus indica* (L.) mill. and *Argania spinosa* L. Skeels. *Industrial Crops and Products* **151**. Elsevier B.V.
- Bushra R. 2018. Functionalized nanomaterials for chromatography. *Nanomaterials in Chromatography: Current Trends in Chromatographic Research Technology and Techniques*:403–414. Elsevier. Available from <https://www.sciencedirect.com/topics/chemistry/retention-time> (accessed February 20, 2024).
- Cantwelp M, Rodrtguez-Felix A, Robles-Contreras F. 1992. Post-harvest physiology of prickly pear cactus stems **3**:1–9.
- Chakir M. 2011, August 25. Morocco taps benefits of Barbary fig oil. Available from <https://english.alarabiya.net/articles/2011%2F08%2F25%2F163986> (accessed February 8, 2024).
- Chbani M, El Harkaoui S, Willenberg I, Matthäus B. 2023. Review: Analytical Extraction Methods, Physicochemical Properties and Chemical Composition of Cactus (*Opuntia ficus-indica*) Seed Oil and Its Biological Activity. *Food Reviews International* **39**:4496–4512. Taylor and Francis Ltd.
- ChemicalBook. 2023a. Linoleic acid. Available from [https://www.chemicalbook.com/ProductChemicalPropertiesCB5764024\\_EN.htm](https://www.chemicalbook.com/ProductChemicalPropertiesCB5764024_EN.htm) (accessed April 1, 2024).
- ChemicalBook. 2023b. Oleic acid | 112-80-1. Available from [https://www.chemicalbook.com/ChemicalProductProperty\\_EN\\_CB7228241.htm](https://www.chemicalbook.com/ChemicalProductProperty_EN_CB7228241.htm) (accessed April 1, 2024).
- ChemicalBook. 2023c. PALMITOLEIC ACID | 373-49-9. Available from [https://www.chemicalbook.com/ChemicalProductProperty\\_EN\\_CB1384985.htm](https://www.chemicalbook.com/ChemicalProductProperty_EN_CB1384985.htm) (accessed April 1, 2024).
- ChemicalBook. 2023d. BEHENIC ACID | 505-56-6. Available from [https://www.chemicalbook.com/ChemicalProductProperty\\_EN\\_CB4283122.htm](https://www.chemicalbook.com/ChemicalProductProperty_EN_CB4283122.htm) (accessed April 1, 2024).



- ChemSpider. 2024a. Compound - Oleic acid. Available from <https://beta.chemspider.com/Chemical-Structure.393217.html> (accessed April 1, 2024).
- ChemSpider. 2024b. Compound - Palmitoleic acid. Available from <https://beta.chemspider.com/Chemical-Structure.393216.html> (accessed April 1, 2024).
- ChemSpider. 2024c. Compound - Stearic acid. Available from <https://beta.chemspider.com/Chemical-Structure.5091.html> (accessed April 1, 2024).
- ChemSpider. 2024d. Compound - behenic acid. Available from <https://beta.chemspider.com/Chemical-Structure.7923.html> (accessed April 1, 2024).
- Chougui N, Tamendjari A, Hamidj W, Hallal S, Barras A, Richard T, Larbat R. 2013. Oil composition and characterisation of phenolic compounds of *Opuntia ficus-indica* seeds. *Food Chemistry* **139**:796–803.
- Ciriminna R, Delisi R, Albanese L, Meneguzzo F, Pagliaro M. 2017. *Opuntia ficus-indica* seed oil: Biorefinery and bioeconomy aspects. *European Journal of Lipid Science and Technology* **119**. Wiley-VCH Verlag.
- Coskun O. 2016. Separation techniques: Chromatography. *North Clin Istanbul* **3**:156–60. Available from [www.kuzeyklinikleri.com](http://www.kuzeyklinikleri.com) (accessed February 20, 2024).
- Del Socorro Santos Díaz M, Barba De La Rosa AP, Héliès-Toussaint C, Guéraud F, Nègre-Salvayre A. 2017. *Opuntia* spp.: Characterization and Benefits in Chronic Diseases. *Oxidative Medicine and Cellular Longevity* **2017**. Hindawi Limited.
- Domenico P. 2021. *Opuntia ficus-indica* the key plant in climate change: characteristics, cultivation and uses. *GSC Biological and Pharmaceutical Sciences* **17**:094–105. GSC Online Press.
- Douglas RE. 2019. Looking at the Past to Understand the Future: Soxhlet Extraction. *LCGC North America* **37**:510–513. Available from <https://www.chromatographyonline.com/view/looking-past-understand-future-soxhlet-extraction> (accessed March 24, 2024).

- El-Mostafa K, El Kharrassi Y, Badreddine A, Andreoletti P, Vamecq J, El Kebbaj MS, Latruffe N, Lizard G, Nasser B, Cherkaoui-Malki M. 2014. Nopal cactus (*Opuntia ficus-indica*) as a source of bioactive compounds for nutrition, health and disease. Page Molecules. MDPI AG.
- Ennouri M, Fetoui H, Hammami M, Bourret E, Attia H, Zeghal N. 2007. Effects of diet supplementation with cactus pear seeds and oil on serum and liver lipid parameters in rats. *Food Chemistry* **101**:248–253.
- FAO. 2017. It's time to put cactus on the menu. Available from <https://www.fao.org/newsroom/detail/It-s-time-to-put-cactus-on-the-menu/en> (accessed April 9, 2024).
- FAO. 2018. Strengthening of fruit and cactus pear production in Ethiopia. Available from <https://www.fao.org/documents/card/fr/c/I8798EN/> (accessed April 4, 2024).
- Farvid M, Ding M, Pan A, Sun Q, Chiuve S, Steffen L, Willett W, Hu F. 2014. Dietary Linoleic Acid and Risk of Coronary Heart Disease: A Systematic Review and Meta-Analysis of Prospective Cohort Studies. Available from <https://www.hsph.harvard.edu/nutritionsource/2014/11/05/dietary-linoleic-acid-and-risk-of-coronary-heart-disease/> (accessed April 2, 2024).
- Fisk HL, West AL, Childs CE, Burdge GC, Calder PC. 2014. The use of gas chromatography to analyze compositional changes of fatty acids in rat liver tissue during pregnancy. *Journal of Visualized Experiments* DOI: 10.3791/51445.
- García FH, Coll LA, Cano-Lamadrid M, Lluch DL, Carbonell Barrachina AA, Murcia PL. 2020. Valorization of Prickly Pear [*Opuntia ficus-indica* (L.) Mill]: Nutritional Composition, Functional Properties and Economic Aspects. Available from [www.intechopen.com](http://www.intechopen.com).
- Garg E, Zubair M. 2023. Mass Spectrometer. StatPearls. StatPearls Publishing. Available from <https://www.ncbi.nlm.nih.gov/books/NBK589702/> (accessed March 4, 2024).
- Gharby S, Harhar H, Charrouf Z, Bouzobaa Z, Boujghagh M, Zine S. 2015. Physicochemical composition and oxidative stability of *Opuntia ficus-indica* seed oil from Morocco. *Acta Horticulturae* **1067**:83–88. International Society for Horticultural Science.

- Ghazi Z, Ramdani M, Fauconnier ML, Mahi B El, Cheikh R. 2013. Fatty acids Sterols and Vitamin E composition of seed oil of *Opuntia Ficus Indica* and *Opuntia Dillenii* from Morocco. *J. Mater. Environ. Sci* **4**:967–972.
- Hammond EW. 2003. FATTY ACIDS | Analysis.
- Hänke H, Barkmann J, Müller C, Marggraf R. 2018. Potential of *Opuntia* seed oil for livelihood improvement in semi-arid Madagascar. *Madagascar Conservation & Development* **13**:34–44.
- Hassan S, Louhaichi M, Kumar S, Naorem A, Inglese P. 2023. Cactus Pear for Sustainable Livelihoods in the Drylands: IPSR Innovation Profile.
- Hernandez EM. 2016. Specialty Oils: Functional and Nutraceutical Properties. *Functional Dietary Lipids: Food Formulation, Consumer Issues and Innovation for Health*:69–101. Woodhead Publishing.
- Hersh E. 2022, January 14. Hyperlipidemia vs. Hypercholesterolemia: What's the Difference? Available from <https://www.healthline.com/health/high-cholesterol/hyperlipidemia-vs-hypercholesterolemia> (accessed April 11, 2024).
- Inglese P, Mondragón-Jacobo C, Nefzaoui A, Sáenz H. C, Food and Agriculture Organization of the United Nations, International Center for Agricultural Research in the Dry Areas. 2018. Crop ecology, cultivation and uses of cactus pear.
- Kaufmann JC. 2004. Prickly Pear Cactus and Pastoralism in Southwest Madagascar. *Autumn* **43**:345–361. Available from <https://www.jstor.org/stable/3774032>.
- Kaur G, Sharma S, Student MS. 2018. Gas Chromatography-A Brief Review. Available from <http://ijics.com/>.
- Khémiri I, Bitri L. 2019. Effectiveness of *Opuntia ficus indica* L. *inermis* Seed Oil in the Protection and the Healing of Experimentally Induced Gastric Mucosa Ulcer. *Oxidative Medicine and Cellular Longevity* **2019**. Hindawi Limited.
- Kiralan M, Ketenoglu O, Kiralan SS, Özkan G. 2021. *Opuntia* spp. Essential oils. Pages 355–367 *Opuntia* spp.: Chemistry, Bioactivity and Industrial Applications. Springer International Publishing.
- Koh YG, Seok J, Park JW, Kim KR, Yoo KH, Kim YJ, Kim BJ. 2023. Efficacy and safety of oral palmitoleic acid supplementation for skin barrier improvement: A 12-week,

- randomized, double-blinded, placebo-controlled study. *Heliyon* **9**:e16711. Elsevier. Available from /pmc/articles/PMC10245245/ (accessed April 2, 2024).
- Koshak AE, Abdallah HM, Esmat A, Rateb ME. 2020. Anti-inflammatory Activity and Chemical Characterisation of *Opuntia ficus-indica* Seed Oil Cultivated in Saudi Arabia. *Arabian Journal for Science and Engineering* **45**:4571–4578. Springer.
- Kvitok. 2024. Organický Opunciový olej 10ml - Kvitok.sk. Available from <https://kvitok.sk/produkt/organicky-opunciovy-olej-10ml/> (accessed March 15, 2024).
- Le Houérou HN. 1996. The role of cacti (*Opuntia* spp.) in erosion control, land reclamation, rehabilitation and agricultural development in the Mediterranean Basin.
- Leníček M. 2014. Separation techniques. Available from <https://ulbld.lf1.cuni.cz/file/4551/separation-techniques.pdf> (accessed February 20, 2024).
- Lopez S, Bermudez B, Pacheco YM, Ortega A, Varela LM, Abia R, Muriana FJG. 2010. Oleic Acid: The Main Component of Olive Oil on Postprandial Metabolic Processes. *Olives and Olive Oil in Health and Disease Prevention*:1385–1393. Academic Press.
- L'Oréal Paris. (n.d.). Behenic Acid Moisturizing & Skin-Soothing Benefits - L'Oréal Paris. Available from <https://www.lorealparisusa.com/ingredient-library/behenic-acid> (accessed April 2, 2024).
- Lundanes E, Reubsaet L, Greibrokk T. 2013. *Chromatography: Basic Principles, Sample Preparations and Related Methods*. Wiley-VCH, Weinheim, Germany.
- Luque de Castro MD, Priego-Capote F. 2010. Soxhlet extraction: Past and present panacea. *Journal of Chromatography A* **1217**:2383–2389.
- Masmoudi M, Baccouche A, Borchani M, Besbes S, Blecker C, Attia H. 2021. Physico-chemical and antioxidant properties of oils and by-products obtained by cold press-extraction of Tunisian *Opuntia* spp. seeds. *Applied Food Research* **1**. Elsevier B.V.
- Matthäus B, Musa Özcan M. 2011. Habitat effects on yield, fatty acid composition and tocopherol contents of prickly pear (*Opuntia ficus-indica* L.) seed oils. *Scientia Horticulturae* **131**:95–98.

- Meyer VR. 2005. CHROMATOGRAPHY | Principles. Available from <https://www.sciencedirect.com/science/article/abs/pii/B0123693977000893> (accessed February 20, 2024).
- Obeidat Y. 2021. The Most Common Methods for Breath Acetone Concentration Detection: A Review. *IEEE Sensors Journal* **21**:14540–14558. Institute of Electrical and Electronics Engineers Inc.
- Pahwa R, Goyal A, Jialal I. 2023. Chronic Inflammation. *Pathobiology of Human Disease: A Dynamic Encyclopedia of Disease Mechanisms*:300–314. StatPearls Publishing. Available from <https://www.ncbi.nlm.nih.gov/books/NBK493173/> (accessed April 3, 2024).
- PubChem. 2024a. Linoleic Acid | C18H32O2 | CID 5280450 - PubChem. Available from <https://pubchem.ncbi.nlm.nih.gov/compound/Linoleic-Acid> (accessed April 1, 2024).
- PubChem. 2024b. Oleic Acid | C18H34O2 | CID 445639 - PubChem. Available from <https://pubchem.ncbi.nlm.nih.gov/compound/Oleic-Acid> (accessed April 1, 2024).
- PubChem. 2024c. Palmitoleic Acid | C16H30O2 | CID 445638 - PubChem. Available from <https://pubchem.ncbi.nlm.nih.gov/compound/Palmitoleic-Acid> (accessed April 1, 2024).
- PubChem. 2024d. Stearic Acid | C18H36O2 | CID 5281 - PubChem. Available from <https://pubchem.ncbi.nlm.nih.gov/compound/Stearic-Acid> (accessed April 1, 2024).
- PubChem. 2024e. Behenic Acid | C22H44O2 | CID 8215 - PubChem. Available from <https://pubchem.ncbi.nlm.nih.gov/compound/8215> (accessed April 1, 2024).
- Ramadan MF, Mörsel J-TM. 2003. Oil cactus pear (*Opuntia ficus-indica* L.) DOI: 10.1016/S0308-8146(02)00550-2. Available from [www.elsevier.com/locate/foodchem](http://www.elsevier.com/locate/foodchem) (accessed February 1, 2024).
- Ramírez-Moreno E, Cariño-Cortés R, Cruz-Cansino N del S, Delgado-Olivares L, Ariza-Ortega JA, Montañez-Izquierdo VY, Hernández-Herrero MM, Filardo-Kerstupp T. 2017. Antioxidant and antimicrobial properties of cactus pear (*Opuntia*) seed oils. *Journal of Food Quality* **2017**. Hindawi Limited.

- Reda TH, Atsbha MK. 2019. Nutritional composition, antinutritional factors, antioxidant activities, functional properties, and sensory evaluation of cactus pear (*Opuntia ficus-indica*) seeds grown in Tigray Region, Ethiopia. *International Journal of Food Science* **2019**. Hindawi Limited.
- Rees M, Gathers RC. 2023, June 13. What is stearic acid? Benefits, side effects, and use. Available from <https://www.medicalnewstoday.com/articles/stearic-acid#benefits> (accessed April 1, 2024).
- Senyilmaz-Tiebe D et al. 2018. Dietary stearic acid regulates mitochondria in vivo in humans. *Nature Communications* **9**. Nature Publishing Group. Available from </pmc/articles/PMC6081440/> (accessed April 1, 2024).
- Taamallah M, Paula P, Alves S, Maria CP, Sousa Bragança J. 2021. Sustainable reuse of prickly pear seeds to extract oil with compound of high interest.
- Tahir HE, Xiaobo Z, Komla MG, Mariod AA. 2019. Nopal cactus (*Opuntia ficus-indica* (L.) Mill) as a source of bioactive compounds. Pages 333–358 in Abdalbasit Adam Mariod, editor. *Wild Fruits: Composition, Nutritional Value and Products*. Springer Nature Switzerland AG, Ghribaish, Sudan.
- Thanonkaew A, Wongyai S, McClements DJ, Decker EA. 2012. Effect of stabilization of rice bran by domestic heating on mechanical extraction yield, quality, and antioxidant properties of cold-pressed rice bran oil (*Oryza sativa* L.). *LWT* **48**:231–236. Academic Press.
- Urban PL. 2016, October 28. *Quantitative mass spectrometry: An overview*. Royal Society of London.
- USDA, NRCS. The PLANTS Database. *Opuntia ficus-indica* (L.) Mill. (n.d.). Available from <https://plants.usda.gov/home/plantProfile?symbol=OPFI> (accessed October 28, 2023).
- Weimann E, Silva MBB, Murata GM, Bortolon JR, Dermargos A, Curi R, Hatanaka E. 2018. Topical anti-inflammatory activity of palmitoleic acid improves wound healing. *PLoS ONE* **13**. PLOS. Available from </pmc/articles/PMC6181353/> (accessed April 1, 2024).

Wolfram RM, Kritz H, Efthimiou Y, Stomatopoulos J, Sinzinger H. 2002. Effect of prickly pear (*Opuntia robusta*) on glucose- and lipid-metabolism in non-diabetics with hyperlipidemia--a pilot study. *Wiener Klinische Wochenschrift* **114**:840–846. Available from <https://europepmc.org/article/med/12503475?query=food&qstring=yes&client=bot> (accessed April 2, 2024)