

BRNO UNIVERSITY OF TECHNOLOGY

Faculty of Electrical Engineering  
and Communication

MASTER'S THESIS

Brno, 2021

Bc. Filip Šmatlo



# BRNO UNIVERSITY OF TECHNOLOGY

VYSOKÉ UČENÍ TECHNICKÉ V BRNĚ

## FACULTY OF ELECTRICAL ENGINEERING AND COMMUNICATION

FAKULTA ELEKTROTECHNIKY  
A KOMUNIKAČNÍCH TECHNOLOGIÍ

## DEPARTMENT OF ELECTRICAL AND ELECTRONIC TECHNOLOGY

ÚSTAV ELEKTROTECHNOLOGIE

## EFFECT OF ENVIRONMENT ON THE PHOTOCATALYTIC PROPERTIES OF COPPER OXIDES

VLIV PROSTŘEDÍ NA FOTOKATALYTICKÉ VLASTNOSTI OXIDŮ MĚDI

MASTER'S THESIS  
DIPLOMOVÁ PRÁCE

**AUTHOR**  
AUTOR PRÁCE

Bc. Filip Šmatlo

**SUPERVISOR**  
VEDOUCÍ PRÁCE

prof. RNDr. Petr Vanýsek, CSc.

BRNO 2021

# Master's Thesis

Master's study program **Electrical Manufacturing and Management**

Department of Electrical and Electronic Technology

**Student:** Bc. Filip Šmatlo

**ID:** 173757

**Year of  
study:** 2

**Academic year:** 2020/21

**TITLE OF THESIS:**

**Effect of environment on the photocatalytic properties of copper oxides**

**INSTRUCTION:**

Become familiar with the issues of photocatalysis of copper oxides as related to decomposition of simple organic compounds. Focus on the effect of aqueous environment on the chemical stability of the catalytic material. Prepare an experiment verifying chemical stability in different aqueous media. Process the obtained data, interpret them and compare the results with similar ones in the literature.

**RECOMMENDED LITERATURE:**

Dle doporučení vedoucího práce.

**Date of project  
specification:** 8.2.2021

**Deadline for submission:** 24.5.2021

**Supervisor:** prof. RNDr. Petr Vanýsek, CSc.

**doc. Ing. Petr Bača, Ph.D.**  
Chair of study program board

**WARNING:**

The author of the Master's Thesis claims that by creating this thesis he/she did not infringe the rights of third persons and the personal and/or property rights of third persons were not subjected to derogatory treatment. The author is fully aware of the legal consequences of an infringement of provisions as per Section 11 and following of Act No 121/2000 Coll. on copyright and rights related to copyright and on amendments to some other laws (the Copyright Act) in the wording of subsequent directives including the possible criminal consequences as resulting from provisions of Part 2, Chapter VI, Article 4 of Criminal Code 40/2009 Coll.

## **Abstract**

In this work the principle of photocatalysis has been described. The main focus are the metal oxide photocatalysts as they are widely used in photocatalytic applications. Various applications of photocatalytic materials have been also described. The most described application is the water treatment as a focus of this work is photocatalytic degradation of organic water pollutants. The discussed photocatalyst was cuprous oxide as it has good photocatalytic degradation properties. The photocatalytic properties of the cuprous oxide for degradation of an organic water pollutant were defined on degradation of a methyl orange dye.

## **Keywords**

Photocatalysis, Cuprous oxide, Water treatment, Methyl orange, Synthesis

## **Abstrakt**

V této práci byl popsán princip fotokatalýzy. Práce se soustřeďuje na kovové oxidy, které mají široké využití ve fotokatalytických aplikacích. Bylo také popsáno různé použití fotokatalytických materiálů. Tato práce se zaměřuje zejména na využití fotokatalytických materiálů pro rozklad organických vodu znečišťujících látek. Popsaný fotokatalyzátor je oxid měďný, který má velmi dobré vlastnosti pro rozklad organických látek pomocí fotokatalýzy. Schopnost rozkladu organických látek oxidu měďného byla popsána na rozkladu organického barviva methylová oranž.

## **Klíčová slova**

Fotokatalýza, Oxid měďný, Úprava vody, Methylová oranž, Syntéza

## Rozšířený abstrakt

V teoretické části semestrální práce jsou vysvětleny základní principy fotokatalýzy. Jsou popsány různé typy fotokatalýz, mezi nejdůležitější z nich patří heterogenní fotokatalýza. Heterogenní fotokatalýza a její zákonitosti jsou popsány podrobněji, jelikož je to typ fotokatalýzy, ke které dochází na povrchu oxidů kovů. Tato práce se podrobněji zabývá oxidy kovů s největším důrazem kladeným na oxid měďný. V práci jsou také popsány nejčastější způsoby využití fotokatalýzy. Mezi tato využití patří štěpení vody, degradace oxidu uhličitého, výroba uhlovodíkových paliv z oxidu uhličitého a úprava vody. Úprava vody pomocí fotokatalýzy byla popsána více detailně, jelikož jedním z cílů práce je rozklad vodu znečišťujících látek a vliv vodného prostředí na fotokatalytické vlastnosti a chemickou stabilitu fotokatalyzátoru. V praktické části této práce je teoreticky popsána syntéza oxidu měďného. Z velkého množství postupů syntézy oxidu měďného byla vybrána metoda syntézy oxidu měďného redukcí síranu měďnatého pomocí kyseliny askorbové. Hlavní faktory pro výběr této metody byly proveditelnost, dostupnost materiálů a úroveň znalosti chemické přípravy autora. Pro zjištění fotokatalytických vlastností oxidu měďného byla popsána metoda měření absorpce roztoku pomocí UV/vis spektrometru. Absorpce roztoku se mění v závislosti na míře rozkladu barviva methylová oranž, čímž je dostatečně dokázána schopnost fotokatalyzátoru oxidu měďného rozkládat organické sloučeniny.

## Bibliographic citation

ŠMATLO, F. *Effect of environment on the photocatalytic properties of copper oxides*. Brno: Brno University of Technology, Faculty of electrical engineering and communications, Dept. of telecommunications, 2021. 40 p. Master's thesis. Advised by Prof. Petr Vanýsek.

## Author's Declaration

**Author:** *Filip Šmatlo*

**Author's ID:** *173757*

**Paper type:** *Master's Thesis*

**Academic year:** *2020/21*

**Topic:** *Effect of environment on the photocatalytic properties of copper oxides*

I declare that I have written this paper independently, under the guidance of the advisor and using exclusively the technical references and other sources of information cited in the project and listed in the comprehensive bibliography at the end of the project.

As the author I furthermore declare that, with respect to the creation of this paper, I have not infringed any copyright or violated anyone's personal and/or ownership rights. In this context, I am fully aware of the consequences of breaking Regulation § 11 of the Copyright Act No. 121/2000 Coll. of the Czech Republic, as amended, and of any breach of rights related to intellectual property or introduced within amendments to relevant Acts such as the Intellectual Property Act or the Criminal Code, Act No. 40/2009 Coll., Section 2, Head VI, Part 4.

Brno, May 21, 2021

-----  
author's signature

## **Acknowledgement**

I want to thank my supervisor, prof. Petr Vanýsek for his invaluable advice and support. Professor helped me with my ideas and fulfilled my gaps in knowledge of my diploma thesis topic. I also would like to thank my family, primarily my mum and dad; I would not be here writing those words without them. My huge thanks also go to Jakub Hyžák; I owe him this one. Other thanks go to Pavel Šafl for his advice and his vast knowledge of 3D printing. Last but not least, I would like to thank Tereзка Smejkalová. Without her immeasurable support, these pages would never see the light of the world.

Brno, May 21, 2021

-----  
author's signature

# Contents

<b>FIGURES</b> .....	<b>8</b>
<b>TABLES</b> .....	<b>9</b>
<b>INTRODUCTION</b> .....	<b>10</b>
<b>1. THEORY OF PHOTOCATALYSIS</b> .....	<b>11</b>
1.1 PRINCIPLE OF CATALYSIS .....	11
1.2 HISTORICAL APPROACH OF PHOTOCATALYSIS .....	11
1.3 PRINCIPLE OF PHOTOCATALYSIS.....	12
1.3.1 <i>Homogeneous photocatalysis</i> .....	13
1.3.2 <i>Heterogeneous photocatalysis</i> .....	13
1.4 APPLICATIONS OF PHOTOCATALYSIS .....	14
1.4.1 <i>Photocatalytic water splitting</i> .....	15
1.4.2 <i>Photocatalytic reduction of CO<sub>2</sub></i> .....	16
1.4.3 <i>Photocatalytic water purification</i> .....	18
1.5 CUPROUS OXIDE AS A PHOTOCATALYST .....	22
1.5.1 <i>Cu<sub>2</sub>O synthesis</i> .....	24
<b>2. PRACTICAL PART AND EXPERIMENTS</b> .....	<b>25</b>
2.1 SYNTHESIS OF Cu <sub>2</sub> O.....	25
2.1.1 <i>Used chemicals</i> .....	25
2.1.2 <i>Synthesis process</i> .....	25
2.2 ANALYSIS OF SYNTHESIZED CUPROUS OXIDE POWDER .....	26
2.2.1 <i>XRD (X-ray powder diffraction)</i> .....	27
2.2.2 <i>SEM (Scanning electron microscope)</i> .....	27
2.2.3 <i>EDX (Energy-dispersive X-ray spectroscopy)</i> .....	29
2.3 PHOTOCATALYTIC ACTIVITY .....	30
2.3.1 <i>Photocatalytic reactor</i> .....	30
2.3.2 <i>Photocatalytic activity measurement results</i> .....	31
2.3.3 <i>Concentration of photocatalyst dependence</i> .....	32
2.3.4 <i>Recyclation of photocatalyst</i> .....	33
2.4 PHOTOCATALYTIC SYSTEM DESIGN .....	34
<b>3. CONCLUSION</b> .....	<b>36</b>
<b>LITERATURE</b> .....	<b>37</b>
<b>SYMBOLS AND ABBREVIATIONS</b> .....	<b>40</b>



# FIGURES

Figure 1-1 Potential energy diagram for a reaction with and without a catalyst [2] .....	11
Figure 1-2 Difference in mechanism of catalytic and photocatalytic reactions [5].....	12
Figure 1-3 Heterogeneous semiconductor photocatalysis [10] .....	14
Figure 1-4 Schematic of "Honda - Fujishima effect" experiment [10] .....	15
Figure 1-5 Energy positions of conducting band and valence band edges at pH 0 for selected metal oxide semiconductors [10] .....	16
Figure 1-6 Schematic of semiconductor photocatalysis of CO <sub>2</sub> [14] .....	17
Figure 1-7 Energy diagram of semiconductor photocatalysts used for CO <sub>2</sub> reduction [14] .....	18
Figure 1-8 Schematics of TiO <sub>2</sub> reduction of oxygen and oxidation of water to H <sub>2</sub> O <sub>2</sub> [5] .....	19
Figure 1-9 Cu <sub>2</sub> O powder.....	23
Figure 1-10 Pourbaix diagram of copper at 25 °C [23] .....	23
Figure 1-11 Crystallographic structure of Cu <sub>2</sub> O [24].....	24
Figure 2-1 Mixing NaOH solution with CuSO <sub>4</sub> solution.....	25
Figure 2-2 Mixing the solution with ascorbic acid .....	26
Figure 2-3 XRD spectrum of Cu <sub>2</sub> O powder.....	27
Figure 2-4 SEM image of Cu <sub>2</sub> O powder.....	28
Figure 2-5 Cu <sub>2</sub> O particles and its morphology .....	28
Figure 2-6 EDX images of Cu <sub>2</sub> O powder .....	29
Figure 2-7 EDX spectrum of Cu <sub>2</sub> O powder.....	29
Figure 2-8 Absorption spectra of methyl orange dye with Cu <sub>2</sub> O photocatalytic powder .....	31
Figure 2-9 Methyl orange dye before (A) and after (B) photocatalytic degradation .....	32
Figure 2-10 Experimental reaction rate of the photocatalyst vs. the concentration of a photocatalyst [27].....	32
Figure 2-11 Degradation ratio dependence on concentration of Cu <sub>2</sub> O photocatalyst .....	33
Figure 2-12 Recyclation of Cu <sub>2</sub> O powder.....	33
Figure 2-13 Photocatalytic system schematic .....	34
Figure 2-14 Photocatalytic chamber .....	35

# TABLES

Table 1-1 Crystallographic data for Cu <sub>2</sub> O [24].....	24
Table 2-1 List of chemicals and their concentrations used for Cu <sub>2</sub> O preparation.....	25
Table 2-2 Calculated degradation data.....	32

# INTRODUCTION

In modern world the demand for innovation of reusable and renewable technologies is ascending more rapidly than ever. The use of fossil fuel as the main source of energy is not ecological and from this process a lot of toxic substances are generated. From the various toxic substances, we can take for example carbon dioxide; a very known greenhouse gas which has been recognized as the main cause of global warming. Another environmental problem is to have enough fresh tap water. As it is the most important need in human life, it is crucial to have effective methods for water treatment and reclamation. For the clean and fresh water, we need to recycle the used water and make it clean again. We need an effective water treatment method to achieve a drinking grade of water. Methods for cleaning the water and the environment must be ecological and economical, as it is also important to have such methods available for poorer countries.

To solve all of these environmental problems a few solutions are already available. For example, photovoltaic plants are used to cover part of the daily energy consumption. This method is not very effective yet but has big potential to change the energy production market. Water treatment can be also accomplished by nature friendly processes. One of the processes is the use of plant roots and bacteria that clean wastewater without need for any additional chemicals.

These environmental healing processes have one main thing in common. The sun is the source of energy that fuels these systems. The sun is most ecological energy source in the world, and it can be used at any place in the world. How much solar energy can be used only depends on the geographic location. All the described environmental problems can be solved by various methods, but there is still one method that can be used to solve all of the different types of these environmental problems at once. This remarkable method is called photocatalysis.

Use of photocatalytic method can be very important in future to solve global environmental crisis. In case of substitution for fossil fuels, the photocatalysis of water can be used for water splitting and we can produce oxygen and hydrogen only from water and solar irradiation. Hydrogen then can be used in fuel cells to produce energy. The toxic substances generated by burning the fossil fuels can be degraded by photocatalytic active materials to basic harmless substances as water, carbon, and oxygen. In case of water treatment the same method can be used for degradation of the various pollutants, such as heavy metals, organic and inorganic compounds, to make perfectly clean water only from using solar irradiation.

# 1. THEORY OF PHOTOCATALYSIS

Catalysis is a process that is commonly used in worldwide applications. Use of this process expanded exponentially over the last few centuries and mostly in the last few decades. It is the backbone of the most of chemical industries and it has its everyday use in various basic and even complex applications. For example, the most known use of catalysis is in the so called catalysts in cars. The main purpose of the car catalyst is to reduce toxic gases and pollutants from engine into less toxic pollutants. This is just one application from the broad use of catalysis.

## 1.1 Principle of catalysis

Catalysts are materials that can accelerate specific reactions and as the reaction occurs, they participate and can change its own state, but when the reaction ends, their state is the same as before the reaction. There is overall change in the free Gibbs energy of the reactants as they are converted to products, but there is no overall change in the free Gibbs energy of the catalyst. So, the catalyst does not and cannot change the energy equilibrium of any reaction. The overall energy needed to initiate the reaction to occur and to products to be developed is decreased with the use of photocatalyst. It is illustrated in Figure 1-1 that the reaction starts at the same energy level with catalyst but the barrier energy (activation energy) that must be crossed for the products to form is lowered with the catalyst [1].

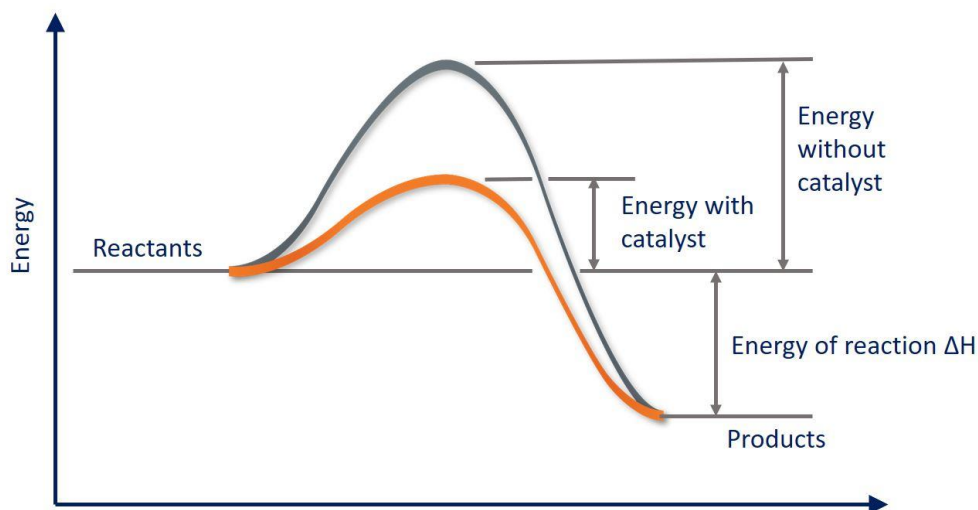

Figure 1-1 Potential energy diagram for a reaction with and without a catalyst [2]

## 1.2 Historical approach of photocatalysis

As the catalysts were more developed and the new materials with catalytical properties were discovered, also the research of the new catalytic processes and methods were approached. One of the new methods of catalysis is photocatalysis, that is basically the

use of catalytic materials, but they themselves do not activate the reaction or decrease the activation energy required for the reaction to occur. Rather, they must be activated by a photon of light to start the reaction.

The first significant breakthrough in photocatalysis was in 1972. In the paper published by Fujishima and Honda the fact that the water photolyzed by illumination of TiO<sub>2</sub> electrode was demonstrated [3]. What followed after publishing this paper in Nature was a series of studies in search of the photocatalytic holy grail. That was to produce H<sub>2</sub> fuel as part of the beginning of the hydrogen economy, a result of the 1973 oil crisis [4].

In the 1980s there was an exponential growth of heterogeneous photocatalysis, with particular emphasis on the use of nanosized TiO<sub>2</sub> particles, which in 2010 alone saw several thousand related publications. Other photocatalysts were developed as well, but the use of TiO<sub>2</sub> as a photocatalyst was in the main interest to all photocatalysis researchers [4].

### 1.3 Principle of photocatalysis

Catalytic reaction takes place on an active site of the catalyst surface. The substrate is changed, and the product of this catalytic reaction is formed. In Figure 1-2 the difference between a catalyst and a photocatalyst is illustrated. Both of these catalytic reactions are heterogeneous (catalyst is in a different phase than reactant). The difference between catalytic and photocatalytic reaction is that in a photocatalytic reaction there is no active site. The reaction occurs on the surface of the photocatalyst, but the substrate does not react with surface. The substrate reacts only with electrons or holes that travelled through the volume of the photocatalyst and that were generated by light. What do these two catalysis materials have in common is that they did not change during the reaction. Eventual degradation of these materials can affect the efficiency of these materials, but this depends only on stability of these materials [5].

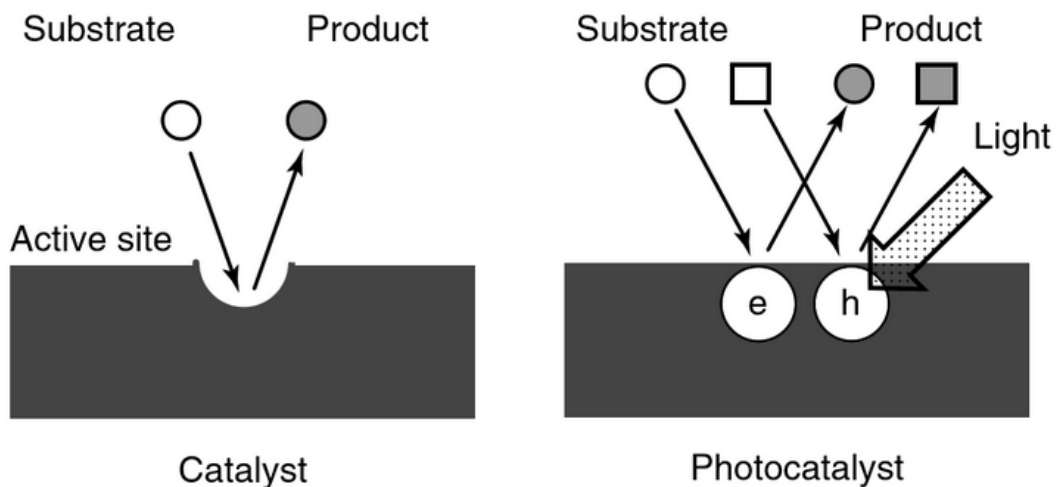

Figure 1-2 Difference in mechanism of catalytic and photocatalytic reactions [5]

In photochemistry various reactions are driven by light. For example, in photolysis light of high enough energy can be used without any catalyst to activate chemical bonds. Photocatalysis is the use of a photon-excited catalyst to accelerate a thermal reaction, in which the catalyst should not undergo a permanent transition but is restored to its initial configuration. The wavelength of the light should be of high enough energy to excite the catalyst, but not necessarily of enough energy for photo-activation of the reactant [6].

There are basically two types of photocatalysis, homogeneous photocatalysis and heterogeneous photocatalysis.

### 1.3.1 Homogeneous photocatalysis

Homogeneous photocatalysts are materials that have photocatalytic properties and are in the same phase as the reactant. One of the homogeneous photocatalysis process is called the photo-Fenton reaction and was described for the first time by Henry Fenton in 1894 [7]. Fenton process is basically degradation of organic substances in the presence of ferrous salts. In the presence of inorganic and organic substances, the reaction pathways are complicated as the organic substances react in many ways with the OH\* radicals generated by the photo-Fenton process [8].

This very complex photocatalytic reaction is among the most efficient methods to generate OH\* radicals. Equations (1) and (2) describe the real reaction processes in a very simplified manner. Complexes and hydroxides of iron play an important role in these reaction cycles [9].

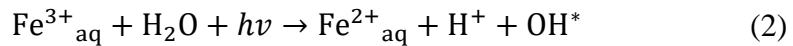
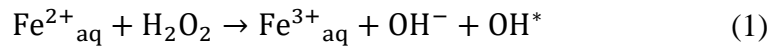

### 1.3.2 Heterogeneous photocatalysis

When a photocatalyst absorbs UV/vis light energy, a transition in electronic state occurs, yielding a photo-excited state. Mostly used heterogeneous photocatalytic materials are metal oxide semiconductors. These materials are crystalline and possess a so called “band gap” which is the energy difference between the highest level of a valence band and the lowest level of the conduction band. These bands contain so called electrons and holes. Electron is a negatively charged particle. When the electron is excited from its ground state a less negative or positive particle will appear in the same place. Hole is often called a virtual particle, because it is not a physical particle; it is just a place that lacks an electron. These two particles, hole or electron, are often called the charge carriers. The nature of active sites (valence and conduction band) created by excitation of crystalline catalysts is typically described by holes which are capable of oxidizing a substrate by accepting an electron, and electrons which are able to reduce a second substrate. One can thus state that two active sites are created upon absorption of one photon [6].

In Figure 1-3 the illustration to describe heterogeneous photocatalysis is presented. When photon is absorbed by photocatalytic material, a few events occur. First of all, excitation of electron from the valence band to the conduction band takes place and as a result a hole is created in the place of its initial state. These particles can travel through material and cause different reactions. Bulk or surface recombination can occur and end with loss of these active particles. The main purpose for these particles is so that they can travel through material separately and cause the oxidation and reduction reactions on surface of a crystalline material [6].

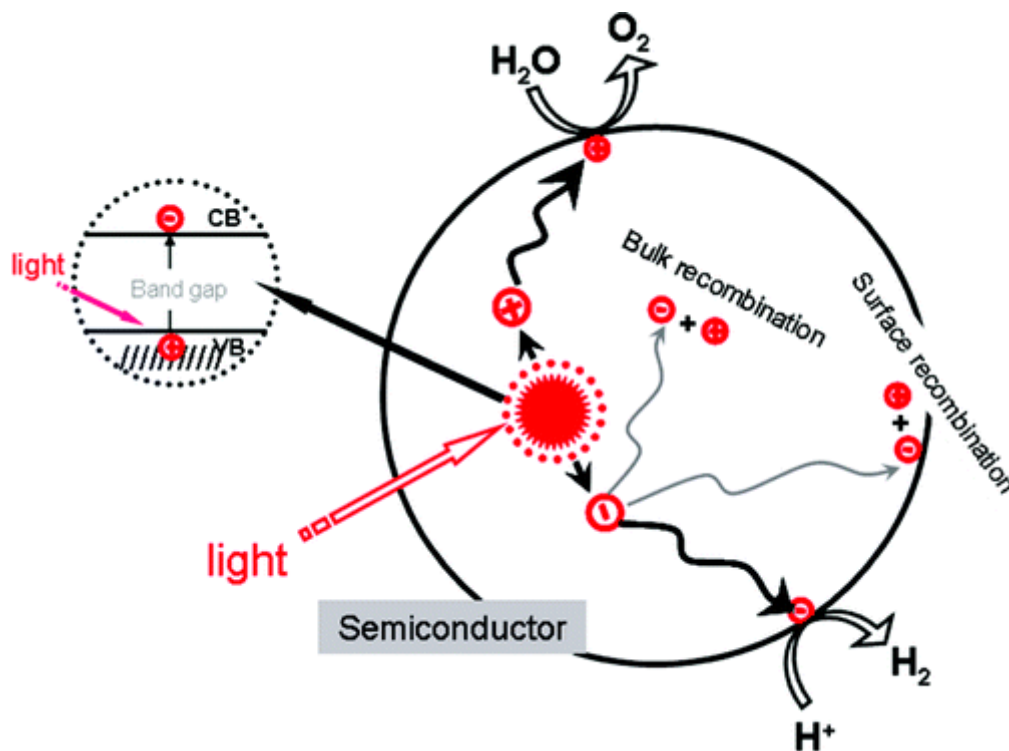

Figure 1-3 Heterogeneous semiconductor photocatalysis [10]

## 1.4 Applications of photocatalysis

The focus on development of photocatalysis has brought a huge variety of use for photocatalysts. Photocatalysts found its use across a broad range of research areas, including especially environmental and energy-related fields, which some of them penetrated to the industrial and commercial use [11].

Semiconductor photocatalysis with a primary focus on transition oxides as a durable photocatalyst has been applied to a variety of problems of environmental interest in addition to water and air purification. It has been shown to be useful for the destruction of microorganisms such as bacteria and viruses, for the inactivation of cancer cells, odour control, photosplitting of water to produce hydrogen and oxygen gas, reduction of greenhouse gases such as CO<sub>2</sub>, fixation of nitrogen, clean-up of oil spills or for production of the hydrophobic and self-cleaning substrates [12].

### 1.4.1 Photocatalytic water splitting

As stated in Chapter 1.2 the significant breakthrough in photocatalysis found its source in the year 1972 and was caused by publication about photolysis of water by illuminating TiO<sub>2</sub> electrode.

In the Fujishima and Honda's [3] pioneering work, the electro-chemical cell they constructed for the decomposition of water into hydrogen and oxygen is shown in Figure 1-4. When the surface of the TiO<sub>2</sub> electrode was irradiated by UV light, as a result of a water oxidation reaction, oxygen evolution occurred at the TiO<sub>2</sub> electrode. Concomitant reduction led to hydrogen evolution at the platinum black electrode. This concept, which emerged from the use of photoelectrochemical cells with semiconductor electrodes, was later applied to the design of a photocatalytic system using semiconductor particles or powders as photocatalysts (Figure 1-3). The electrodes were separated by ceramic diaphragm that prevents the unwanted flow of ions. [10] [3]

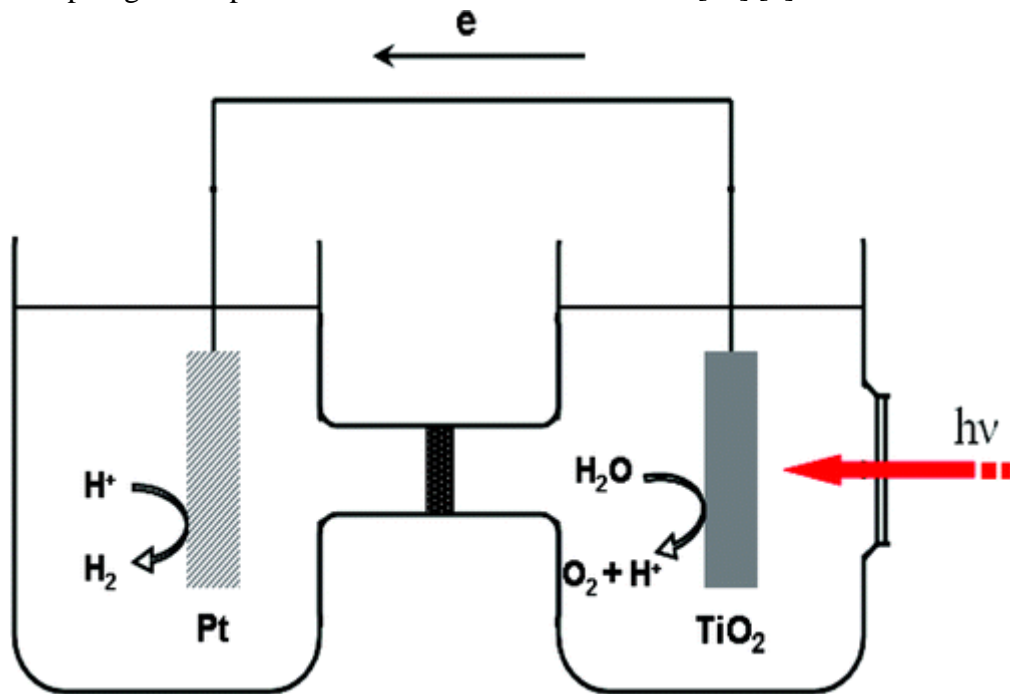
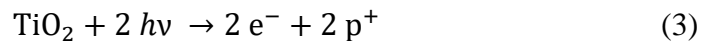
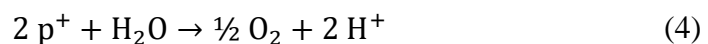

Figure 1-4 Schematic of "Honda - Fujishima effect" experiment [10]

Honda and Fujishima then suggested that water can be decomposed by visible light into oxygen and hydrogen, without the application of any external voltage, according to the following reactions:



(excitation of TiO<sub>2</sub> by light)



(at the TiO<sub>2</sub> electrode)



(at the platinum electrode)



The overall reaction is:

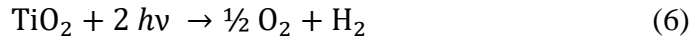

To facilitate both the reduction and oxidation of H<sub>2</sub>O by photoexcited electrons and holes, the match of the band gap and the potentials of the conduction and valence bands is important. Both the reduction and oxidation potentials of water should lie within the band gap of the photocatalyst. The bottom level of the conduction band has to be more negative than the reduction potential of H<sup>+</sup>/H<sub>2</sub> (0.00 V vs. normal hydrogen electrode (NHE)), whereas the top level of the valence band has to be more positive than the oxidation potential of O<sub>2</sub>/OH<sup>-</sup> (1.23 V). Figure 1-5 shows the conduction band edge and valence band edge of some oxide-based semiconductor materials at pH 0. For correcting the values to show valence and conduction band of shown semiconductors at pH 7, it is needed to add to y-axis values approximately 0.1 eV. We can see that there are many semiconductor systems whose electronic structures match well with the redox potential of water into hydrogen and oxygen molecules. The band structure requirement is a thermodynamic requirement for water splitting [10].

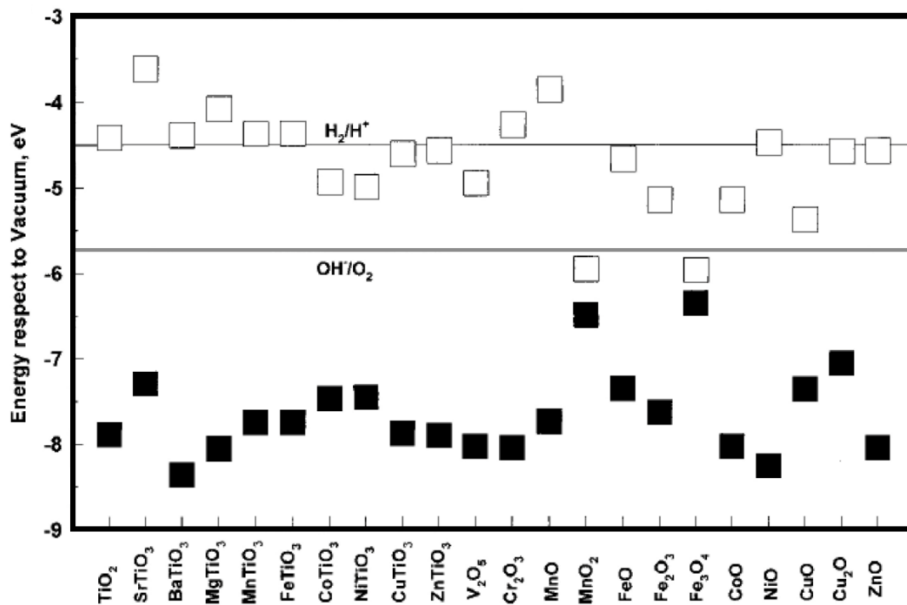

Figure 1-5 Energy positions of conducting band and valence band edges at pH 0 for selected metal oxide semiconductors [10]

#### 1.4.2 Photocatalytic reduction of CO<sub>2</sub>

CO<sub>2</sub> emissions mostly from combustion of fossil fuels have been widely recognized as the main source of global warming. The reduction of CO<sub>2</sub> has recently been regarded as an important research area, not only for solving problems resulting from environmental pollution but also for finding ways to maintain carbon resources that are being depleted by fossil fuel combustion. The high fuel consumption in modern society will lead to an energy crisis if suitable alternative energy sources cannot be found. One possible solution for this problem is photocatalytic CO<sub>2</sub> reduction which offers a promising way for low

cost, clean and environmentally friendly production of fuels by solar energy, with lower energy input. [13]

CO<sub>2</sub> is a chemically stable compound due to its carbon oxygen bonds. Its conversion to carbon-based fuels requires substantial energy input for bond split. Renewable carbon free sources like solar energy provide readily available and continuous energy supply required for driving this conversion process. CO<sub>2</sub> photocatalytic reduction offers the possibility of utilizing captured CO<sub>2</sub> to synthesize chemicals and fuels with the aid of semiconductor catalysts under light irradiation. Figure 1-6 illustrates the typical photocatalytic process [14].

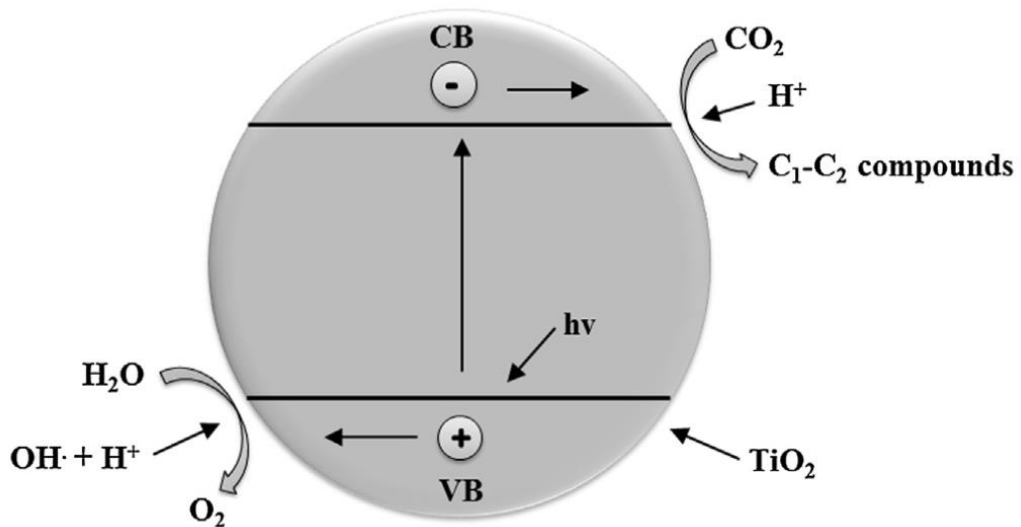
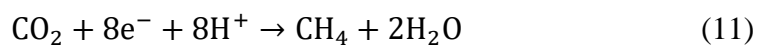
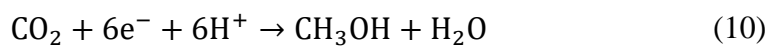
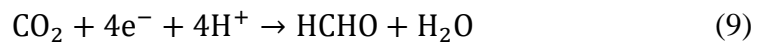
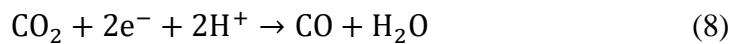

Figure 1-6 Schematic of semiconductor photocatalysis of CO<sub>2</sub> [14]

Possible CO<sub>2</sub> photocatalytic reduction reactions and its products:



A suitable photocatalyst for CO<sub>2</sub> reduction must fulfil the following several demands: (1) multiple electrons must easily migrate from photocatalyst to CO<sub>2</sub>; (2) photocatalyst's conduction band bottom level must be more negative than the redox potentials of CO<sub>2</sub> and its reduced products (Figure 1-7); (3) reactants such as H<sub>2</sub>O, CO<sub>2</sub> or carbonated

species should be adsorbed on the catalyst, so the product molecules could desorb and diffuse into the system after the CO<sub>2</sub> reduction process; (4) the photogenerated holes on the valence band of a semiconductor should be consumed by oxide species such as additional sacrificial reagents or H<sub>2</sub>O. Otherwise, the accumulated holes could be annihilated by the photogenerated electrons or force the chemical reactions that consume the reduced products of CO<sub>2</sub> [15].

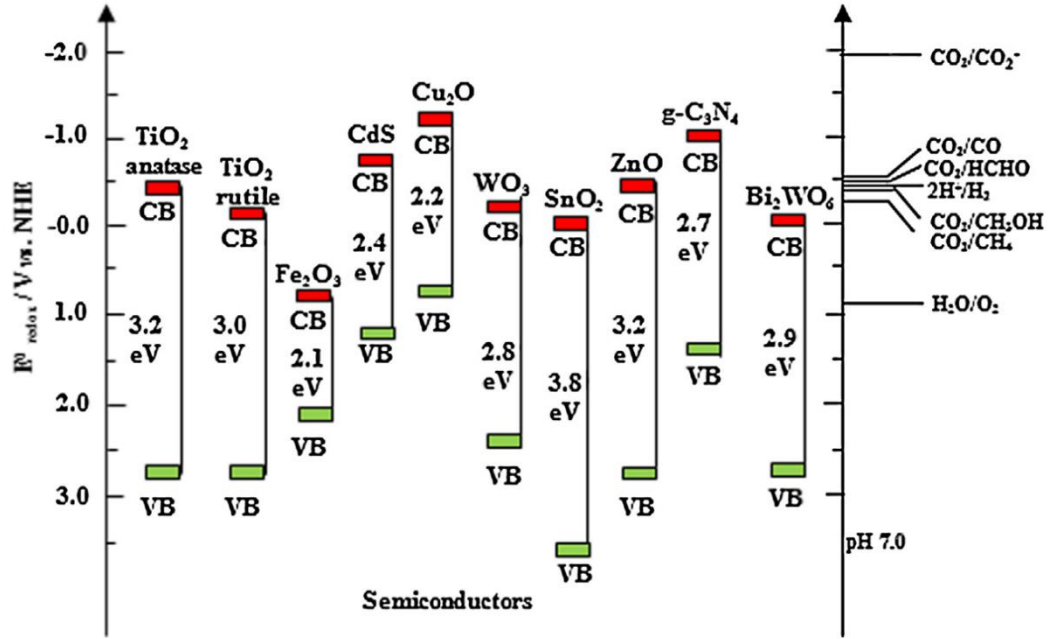

Figure 1-7 Energy diagram of semiconductor photocatalysts used for CO<sub>2</sub> reduction [14]

### 1.4.3 Photocatalytic water purification

Due to the environmental importance, variable methods for the removal of contaminants from wastewater are required. Traditional methods of removal include coagulation, membrane separation and secondary pollutant generation. Recently, one of the major problems of water pollutants is the dyes from various industries such as paper, tannery or pharmaceutical. These dyes are very hazardous to the biotic organisms. Industrial wastewater usually may also contain heavy metals, pesticides, and other organic and inorganic compounds. Photocatalysis has emerged promising technology for wastewater treatment and is becoming an important part of the degradation process [16].

Degradation of pollutants consists of many kinds of reactions after illumination of semiconductor particles. Figure 1-8 shows electron reduction of oxygen to OH\* radical and two-electron oxidation step of water to H<sub>2</sub>O<sub>2</sub> observed in the TiO<sub>2</sub> photocatalyst [5]. It is clear that photocatalytic water purification process involves a series of steps, which includes generation of OH\* radicals. These radicals have strong oxidizing power and could degrade many organic pollutants as well as convert bioresistant materials into harmless products [17].

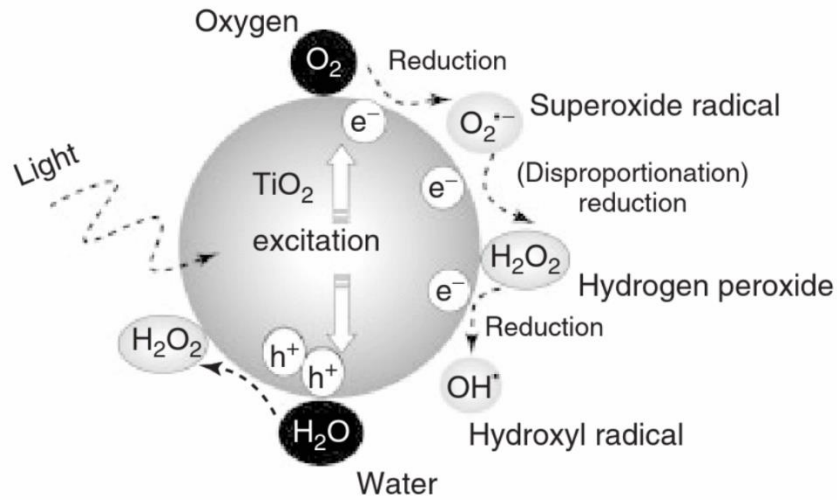

Figure 1-8 Schematics of TiO<sub>2</sub> reduction of oxygen and oxidation of water to H<sub>2</sub>O<sub>2</sub> [5]

As stated, photocatalytic water treatment involves various pollutant degradation processes. A few methods of removal of contaminants from wastewater are listed below.

#### Water treatment methods:

- **Removal of trace metals**

Trace metals including lead, chromium and mercury are considered to be highly hazardous to health and thus, the removal of these toxic metals is important for human health and water quality. Water treatment-based photocatalytic processes include the removal of these heavy metals. The photoreduction ability of photocatalysis has also been used to recover expensive metals, such as platinum, gold and silver from industrial effluent. Heavy metals can be removed from wastewater as small crystallites deposited on the surface of the photocatalyst according to the redox process [13].

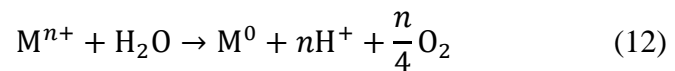

- **Removal of inorganic compounds**

Some inorganic compounds are sensitive to photochemical transformation on the photocatalytic surface. A wide range of inorganic species, such as nitric oxide, bromate, chlorate, halide ions, cyanides, ammonia, nitrites, metal salts and organometallic compounds can be removed from water by photocatalytic process. TiO<sub>2</sub> photocatalytic reactions for removal of toxic inorganics [13]:

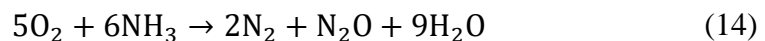
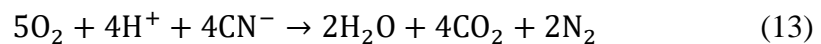

- **Degradation of organic pollutants**

Photocatalysis has been used for the transformation of organic compounds (carboxylic acids, alcohols and chlorinated aromatics) into harmless products including carbon dioxide, water and simple mineral acids. Water contaminated by oil substances can be treated with high efficiency by photocatalytic reaction. Herbicides and pesticides that may contaminate water, for example 1,1,1-trichloro-2,2-di(4-chlorophenyl)ethane (DDT), have also been successfully removed. TiO<sub>2</sub> photocatalytic reactions for degradation of organic pollutants include [13]:

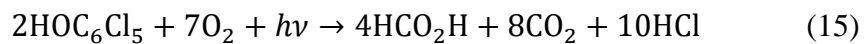

(degradation of pentachlorophenol)

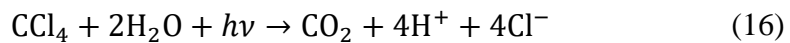

(degradation of carbon tetrachloride)

Photocatalytic oxidation of organic compounds is of considerable interest for environmental applications and in particular for the control and eventual destruction of hazardous wastes. Hoffmann et al. [18] reported in their papers the completed mineralization (oxidation of organic compounds to CO<sub>2</sub>, H<sub>2</sub>O and associated inorganic components such as HCl, HBr, SO<sub>4</sub><sup>2-</sup>, NO<sub>3</sub><sup>-</sup>, etc.) of a variety of aliphatic and aromatic chlorinated hydrocarbons via heterogeneous photooxidation on TiO<sub>2</sub> and other semiconductor photocatalytic materials. For example, ZnO photocatalytic degradation of acetic acid proceeds as follows [18]:

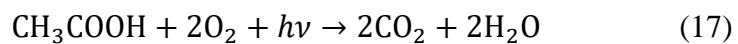

Photocatalytic water treatment is very dependent on environmental effects. The several environmental effects that affect photocatalytic properties of photocatalyst are listed below.

- Wavelength of the used light

The variation of the reaction as a function of the wavelength follows the absorption spectrum of the photocatalyst and corresponds to the photocatalyst band gap energy [13].

- Light intensity

The apparent rate constant of photodegradation increases with an increase in UV irradiation because more photons fall on the photocatalyst, thereby enhancing the production of hydroxyl radicals. At low illumination intensity (0 - 20 mW/cm<sup>2</sup>), the degradation rate is of the first order intensity, while at

moderately high intensity, the reaction rate increases with an increase in the square root of the intensity level because charge carrier (electron-hole pair) separation competes with the recombination process [13].

- pH of polluted solution

The operating pH affects the isoelectric point and the surface charge of the photocatalyst used. The point of zero charge is a condition at which the surface charge is zero or neutral and lies in the pH range of 4.5 – 7.0, depending on the photocatalyst used. At the point of zero charge there are no electrostatic forces at the surface of the photocatalysts and thus, interactions between the photocatalyst particles and water contaminants are at a minimum. When the operating pH is lower than the point of zero charge, the surface charge for the photocatalyst becomes positively charged, thereby increasing electrostatic attraction toward the negatively charged compounds. Such polar attractions between the photocatalysts and charged anionic organic compounds can intensify adsorption onto the photocatalyst surface [13].

- Temperature

Because of the photonic activation, the photocatalytic systems do not require heating and are operating at room temperature. The true activation energy is nil, whereas the apparent activation energy is often very small (a few kJ/mol) in the medium temperature range (between 20 and 80 °C). However, at very low temperatures (below 0 °C) the apparent activation energy increases. On the other hand, when temperature increases above 80 °C and is approaching the boiling point of water, the exothermic adsorption of reactants becomes disfavoured and tends to become the rate limiting step. Correspondingly, the activity decreases, and the apparent activation energy becomes negative. The optimum temperature is generally found between 20 and 80 °C. This absence of heating is attractive for photo-catalytic reactions carried out in aqueous media and in particular for photocatalytic water purification [19].

- Dissolved oxygen

In semiconductor photocatalysis for water purification, the pollutants are usually organic. The photomineralization of pollutant does not occur unless O<sub>2</sub> is present. Oxygen is necessary for complete mineralization and does not seem to be competitive with other reactants. According to Malato et al. [20] and references therein the concentration of oxygen affects the reaction rate, but it seems that the effect of concentration is not significant [20].

- Concentration of contaminants

A high concentration of pollutants in water saturates the photocatalyst surface, and thus reduces the photocatalytic efficiency, and in the consequence deactivates the photocatalyst [13].

## 1.5 Cuprous oxide as a photocatalyst

The majority of photocatalytic processes use the  $\text{TiO}_2$  semiconductor as a photocatalysts. In the first breakthrough article published by Honda and Fujishima in Nature 1972 [3] they used  $\text{TiO}_2$  as a photocatalyst. Since then, the  $\text{TiO}_2$  was and is still used as a major photocatalyst in most of photocatalytic applications and processes. Throughout the years of research of photocatalysis and development of new photocatalysts a lot of different semiconductor (in terms of semiconductor heterogeneous photocatalysis) photocatalysts were discovered. These semiconductors have a huge variety of slightly different parameters. The main difference of these photocatalysts being band gap and the positions of valence and conductive bands in energy diagrams. As seen in Figures 1-5 and 1-7 the position of valence and conductive band is important in photocatalytic processes. Different photocatalysts may have better properties for use in photocatalytic water splitting than in  $\text{CO}_2$  reduction.

From the copper metal oxides, the highest potential of use has the monovalent cuprous oxide ( $\text{Cu}_2\text{O}$ ).  $\text{Cu}_2\text{O}$  is among the numerous transition metal semiconducting oxides of intense interests and has been extensively investigated for its distinctive properties.  $\text{Cu}_2\text{O}$  is a reddish p-type semiconductor with a direct bandgap of 2.0 - 2.2 eV, which has been often researched for application in solar energy converting devices. It has the potential to form a solar cell by combination with a suitable n-type semiconductor. A major attraction of  $\text{Cu}_2\text{O}$  is that it has low toxicity and good environmental acceptability, is relatively inexpensive, plentiful, and readily available.  $\text{Cu}_2\text{O}$  has been widely exploited for use in the fields of photocatalyst, solar energy conversion, antifouling coatings, photoelectrode in electrochemical cells, water-splitting, and water treatment materials [21].



Figure 1-9 Cu<sub>2</sub>O powder

Band gap of cuprous oxide corresponds to wavelength 563 nm. That means the wavelength of photon must be 563 nm and lower to generate an electron-hole pair. In solar spectrum it is in part with highest fraction of solar energy and goes down to UV part of spectrum with higher energy irradiation. For comparison with TiO<sub>2</sub> which has the band gap energy 3.2 eV and must be irradiated by light with wavelength of 387 nm. So, we can use larger part of solar spectrum by using Cu<sub>2</sub>O as a photocatalyst. Instead of TiO<sub>2</sub> which works more in UV part of solar spectrum. [22]

Based on the Pourbaix diagram of copper the Cu<sub>2</sub>O solid phase is very stable as it is in the water stability region and does not corrode or passivate. Cu<sub>2</sub>O is most stable in neutral and alkaline water solutions. At a higher potential Cu<sub>2</sub>O oxidizes to CuO. CuO is also semiconductor but has negative influence on photocatalytic behaviour of Cu<sub>2</sub>O.

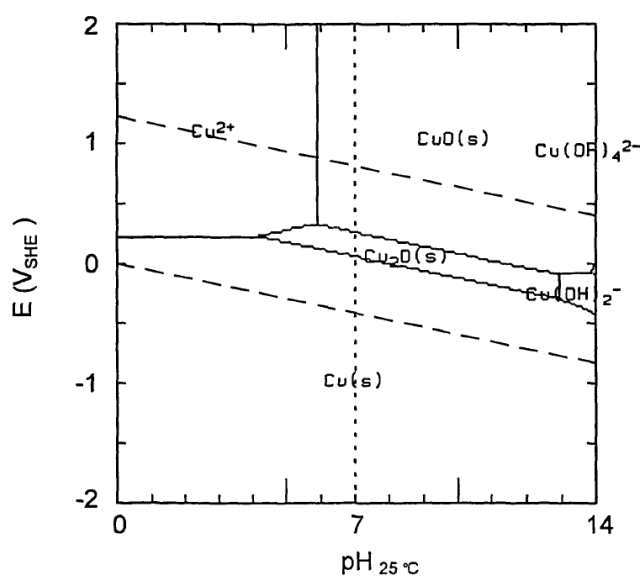

Figure 1-10 Pourbaix diagram of copper at 25 °C [23]



Cu<sub>2</sub>O is known to be the only stable copper metal oxide with the oxidation state +1. Cu<sub>2</sub>O has the mineral cuprite crystal structure, in which the copper (I) cations, Cu<sup>+</sup>, are arranged into a face centred cubic sublattice and the oxygen anions, O<sup>2-</sup>, reside on the sites of a body-centred cubic sublattice. Each O<sup>2-</sup> is tetrahedrally coordinated by Cu<sup>+</sup>, whereas the coordination of Cu<sup>+</sup> ions is linear [24].

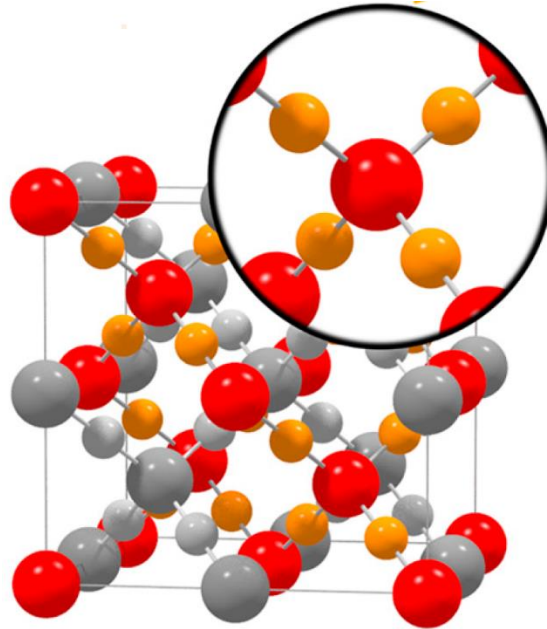

Figure 1-11 Crystallographic structure of Cu<sub>2</sub>O [24]

Table 1-1 Crystallographic data for Cu<sub>2</sub>O [24]

Formula	Space group	Lattice parameter [Å]	Ion	Position	x	y	z
Cu <sub>2</sub> O	<i>Pn</i> $\bar{3}$ <i>m</i> , No. 224	a = 4.30	O <sup>2-</sup>	2a	0	0	0
	cubic		Cu <sup>+</sup>	4b	1/4	1/4	1/4

### 1.5.1 Cu<sub>2</sub>O synthesis

For basic synthesis of Cu<sub>2</sub>O the reduction of CuSO<sub>4</sub> method is described. Zhang et al. [25] prepared Cu<sub>2</sub>O nanoparticles by reducing CuSO<sub>4</sub> using ascorbic acid at room temperature. Most of the synthetic strategies to preparation of Cu<sub>2</sub>O involve surfactants or template reagents. Zhang et al. successfully prepared Cu<sub>2</sub>O nanoparticles without using any template or surfactant [25].

All reagents used in Zhang et al. work were of analytical grade and were used without any further purification. In a typical procedure, 40 ml (0.5 mol/l) aqueous solution of NaOH were added into 20 ml of aqueous solution of CuSO<sub>4</sub> (0.5 mol/l) with stirring. Then, 50 ml (0.1 mol/l) of ascorbic acid aqueous solution was dropwise added into the above solution with vigorous stirring at room temperature. After 30 minutes a red precipitate was observed. The precipitate particles were separated from the solution by centrifugation at 1000 rpm for 15 min. The product was washed by distilled water and absolute ethanol. The final product was dried in vacuum at 60 °C (more than 6 h) [25].

## 2. PRACTICAL PART AND EXPERIMENTS

Main focus of the practical part of this thesis was to synthesize  $\text{Cu}_2\text{O}$  powder and do a various analytical methods to prove the quality of synthesized  $\text{Cu}_2\text{O}$  powder. The analysis were XRD, EDX and SEM. To prove the photocatalytic activity of synthesized powder the UV/vis spectroscopy was used to measure the absorption of polluted water.

### 2.1 Synthesis of $\text{Cu}_2\text{O}$

The synthesis of  $\text{Cu}_2\text{O}$  was based on Zhang et al. method (Chapter 1.5.1). The  $\text{Cu}_2\text{O}$  powder was synthesized from  $\text{CuSO}_4$  by a reduction reaction. During the work on this diploma thesis a few batches of  $\text{Cu}_2\text{O}$  were prepared with all of them proceeding with the same preparation method.

#### 2.1.1 Used chemicals

The amount of used chemicals was determined based on approximated value of the required amount of the product  $\text{Cu}_2\text{O}$ . Chemicals listed in Table 2-1 were used for preparation of 5g of the  $\text{Cu}_2\text{O}$  powder.

Table 2-1 List of chemicals and their concentrations used for  $\text{Cu}_2\text{O}$  preparation

	Volumes	Weight of raw material	Molar concentration
NaOH	400 ml	24 g	0.5 mol/l
$\text{CuSO}_4$	200 ml	25 g	0.5 mol/l
Ascorbic acid	500 ml	8.8 g	0.1 mol/l

#### 2.1.2 Synthesis process

All the used chemicals listed in Table 2-1 were mixed before the preparation. NaOH and  $\text{CuSO}_4$  are very stable chemicals and do not need to be dissolved just before the preparation, but the ascorbic acid is oxidized in water so it cannot be prepared long before the  $\text{Cu}_2\text{O}$  preparation.

As in Zhang et al. paper the aqueous solution of NaOH was added into  $\text{CuSO}_4$  solution with stirring. Formation of the precipitate was observed immediately (Figure 2-1 A, B). The precipitate seen on Figure 2-1 B is most likely a form of  $\text{CuOH}$ .

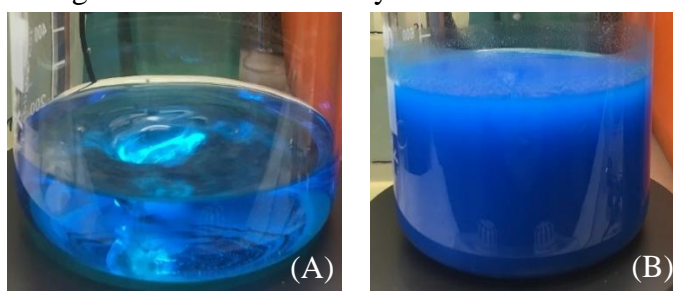

Figure 2-1 Mixing NaOH solution with  $\text{CuSO}_4$  solution

After the precipitate was mixed, homogeneous ascorbic acid aqueous solution was dropwise added into the above solution with vigorous stirring at room temperature. The bluish solution started to change colour from blue to green to orange and after 20 minutes the red precipitate was observed (Figure 2-2 A-F).

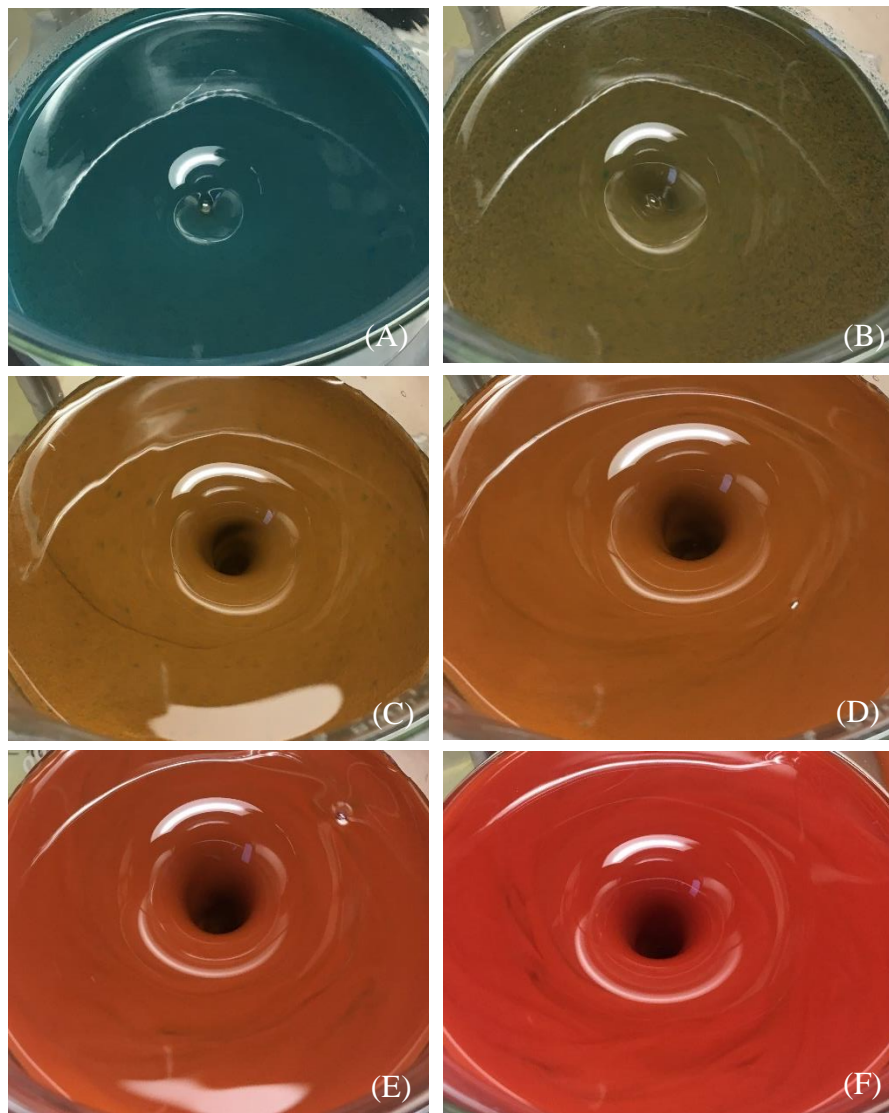

Figure 2-2 Mixing the solution with ascorbic acid

After 30 minutes the stirring was stopped, and the red precipitate immediately went to the bottom of the beaker. The residual solution with the precipitate was filtered with a glass sinter filtration funnel and washed with distilled water and absolute ethanol. Washed powder was then dried in vacuum at 60 °C for 8 hours. The synthesized powder was then weighted and ready for further analysis.

## 2.2 Analysis of synthesized cuprous oxide powder

Various analytical methods were used to determine the purity of the photocatalyst, the efficiency of synthesis and the photocatalytic activity of the synthesized  $\text{Cu}_2\text{O}$  powder.

### 2.2.1 XRD (X-ray powder diffraction)

The XRD analysis shows that the cuprous oxide powder is pure. Comparing the measured spectrum with database of XRD spectra of various materials it was confirmed that the synthesized material was 100 %  $\text{Cu}_2\text{O}$  (mineral cuprite). The crystallographic data measured by XRD analysis are the same as the theoretical crystallographic data mentioned in Chapter 1.5. Cubic facet with space group  $Pn\bar{3}m$ , No. 224. Lattice parameter  $a=b=c=4.268 \text{ \AA}$ . Size of crystallites was  $1.55 \mu\text{m}$  and the powder was crystalline with absence of any nanoparticles. None other crystalline phases are significantly visible so it is obvious that other crystalline phases could be present only at a maximum of few percent. [The XRD spectra were measured by Ing. L. Chladil, Ph.D. on X-ray diffractometer Rigaku]

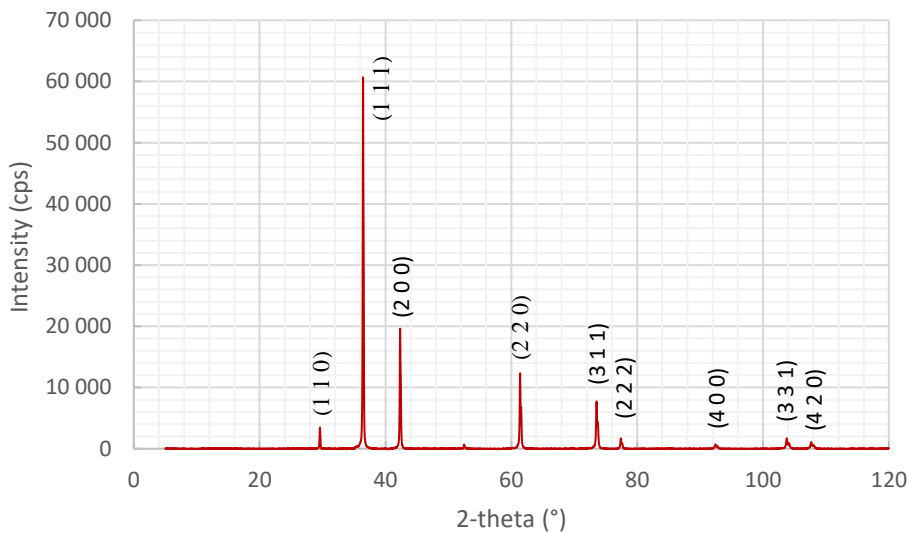

Figure 2-3 XRD spectrum of  $\text{Cu}_2\text{O}$  powder

### 2.2.2 SEM (Scanning electron microscope)

SEM image (Figure 2-4) shows the structure of  $\text{Cu}_2\text{O}$  powder. The size of the  $\text{Cu}_2\text{O}$  particles varies from 200 nm to  $2 \mu\text{m}$ . From the analysis of SEM image, it is clear that the particles seem round but after further investigation it is visible that the particles are actually edge- and corner-truncated (Figure 2-5 A, B).

Edge- and corner-truncated octahedra have more edges and corners which could improve photocatalytic activity. Because the  $\text{Cu}_2\text{O}$  crystals have a strong adsorption capacity for oxygen molecules, the electrons available on the facets of the  $\text{Cu}_2\text{O}$  crystals may be scavenged by adsorptive  $\text{O}_2$  to yield  $\text{O}^{2-}$ , which further reacts with  $\text{H}_2\text{O}$  and electrons to produce hydrogen peroxide ( $\text{H}_2\text{O}_2$ ) and the hydroxyl radical ( $\text{OH}^*$ ) which can fuel any photocatalytic process [26].

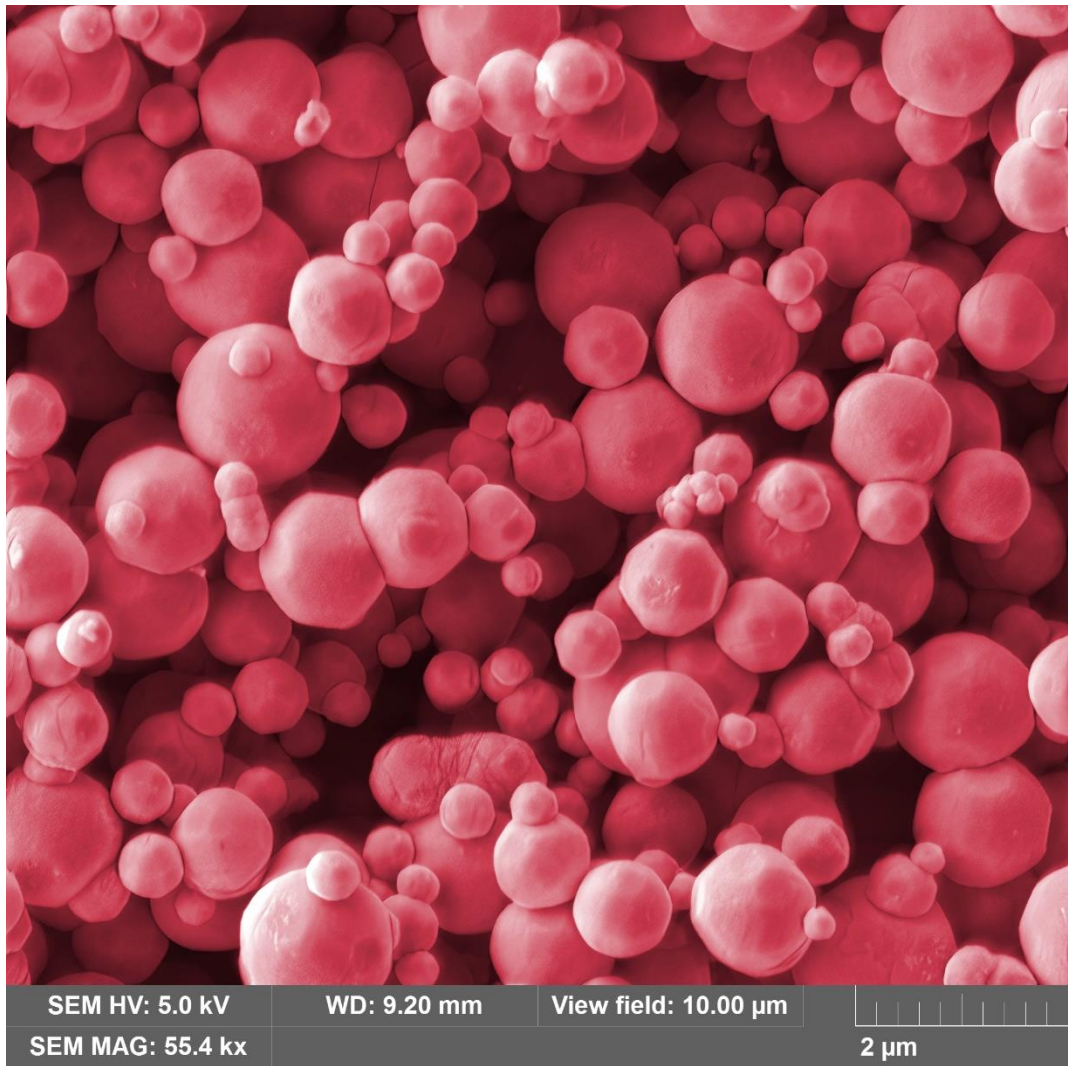

Figure 2-4 SEM image of  $\text{Cu}_2\text{O}$  powder

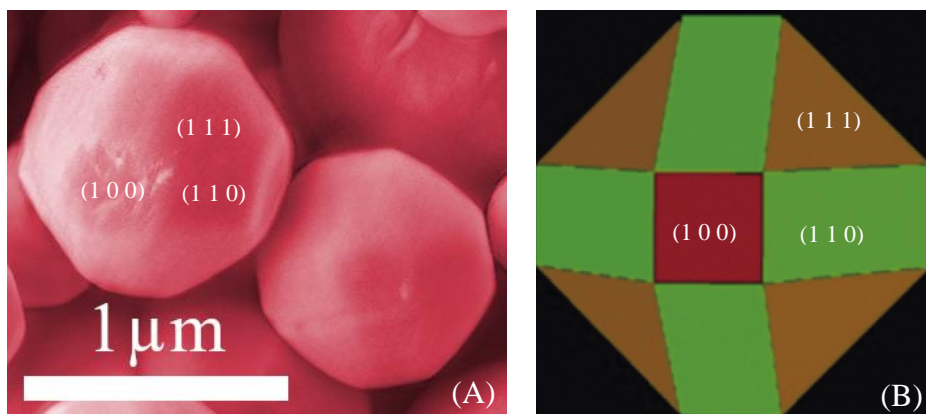

Figure 2-5  $\text{Cu}_2\text{O}$  particles and its morphology

### 2.2.3 EDX (Energy-dispersive X-ray spectroscopy)

EDX analysis is complementary analysis to SEM. Based on EDX measurement the purity and elemental structure was achieved. Figure 2-6 B, C shows the distribution of the elements copper and oxygen. It is clearly visible that the element distribution corresponds with the SEM image of the same area (Figure 2-6 A). From EDX analysis calculations the atomic percentage of copper and oxygen elements was determined. Copper with atomic percentage 67.9 % and oxygen with 32 %. The rest 0.1 % could be carbon as it is ubiquitous element. This detection corresponds with XRD analysis and shows that the ratio of copper and oxygen is 2:1 which represents the  $\text{Cu}_2\text{O}$  molecule.

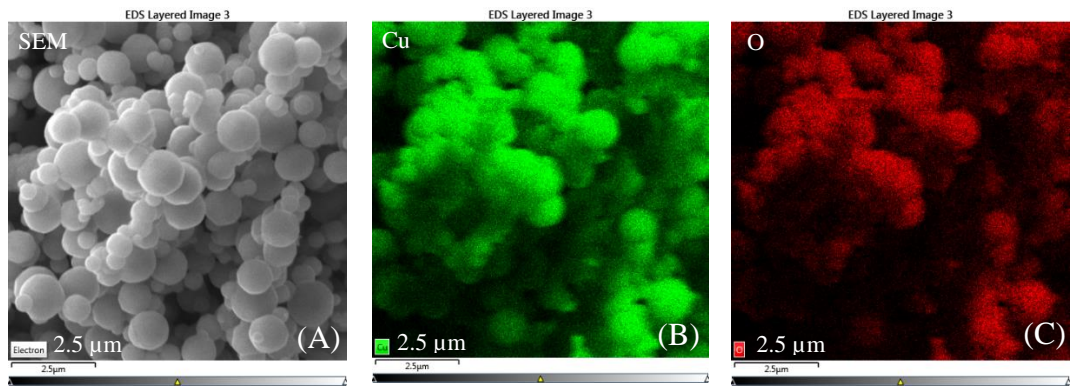

Figure 2-6 EDX images of  $\text{Cu}_2\text{O}$  powder

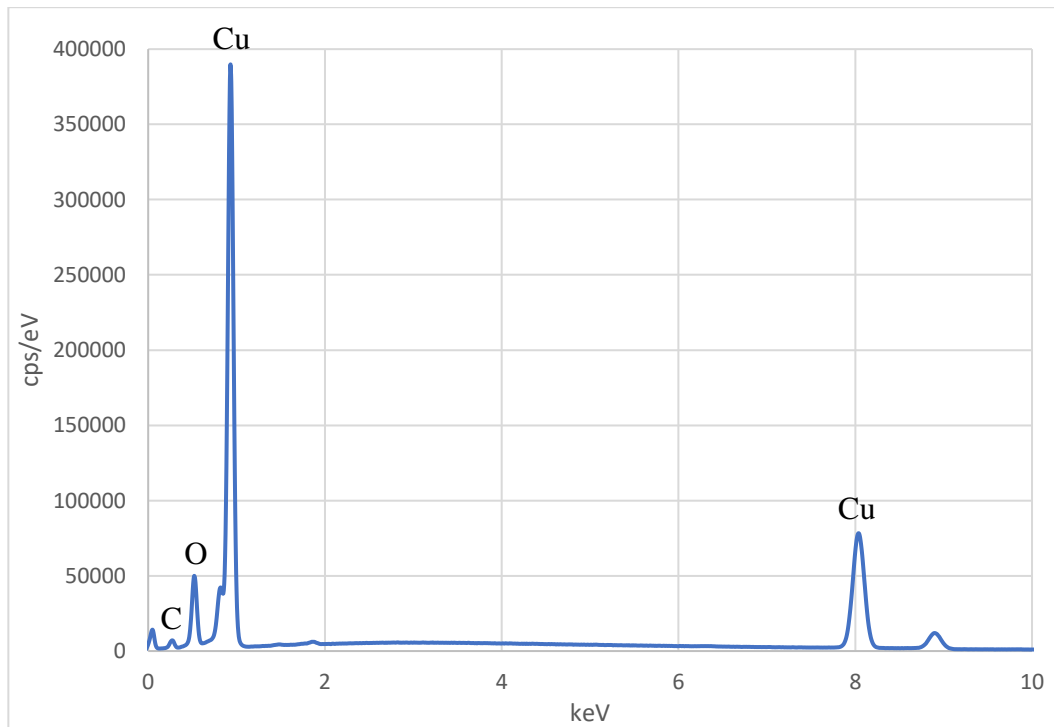
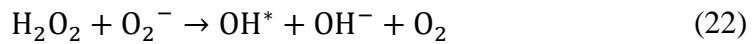
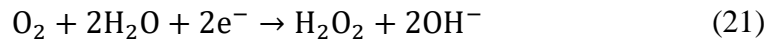
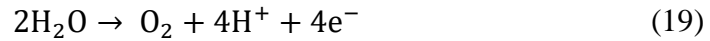
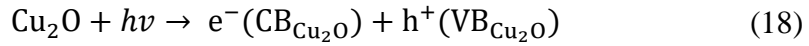

Figure 2-7 EDX spectrum of  $\text{Cu}_2\text{O}$  powder

## 2.3 Photocatalytic activity

The photocatalytic properties of synthesized Cu<sub>2</sub>O powder were measured on photocatalytic degradation of methyl orange dye. Methyl orange dye serves as model of organic pollutant. Water purification photocatalysis process is described in Chapter 1. 4. 3. Methyl orange dye degradation reactions are described below [26].



For the photocatalytic activity measurement, the UV/vis spectroscopy method was used. The spectrophotometer Helios Delta by ThermoFisher Scientific was used to measure the visible absorption spectrum of the methyl orange solution. The degradation rate of the methyl orange was measured by the decrease of absorption.

### 2.3.1 Photocatalytic reactor

The whole measurement system contains a beaker with methyl orange dye solution, a pipette for taking the samples, a cuvette that holds the sample of a solution for the measurement of absorption and a light source that drives the photocatalytic reaction. The light source was assembled from a LED light strip that contained 30 LEDs with the total power of 7.2 W, which approximately corresponds with the power of a 70 W incandescent lightbulb.

The concentration of methyl orange solution was 10 mg/l. With continuous stirring the Cu<sub>2</sub>O powder with concentration of 4 g/l was poured into the solution. All those steps of measurement were done in dark as to not start the photocatalytic reaction unintentionally. First sample was taken and the absorption of methyl orange solution with Cu<sub>2</sub>O powder was measured. The first absorption spectrum of methyl orange was used as a reference. Simultaneously with the absorption measurement the source of light was turned on and the photocatalytic degradation of methyl orange was started. The

measurement of absorption of methyl orange solution was done every 30 minutes for 3 hours.

### 2.3.2 Photocatalytic activity measurement results

For the determination of photocatalytic activity, the peak of methyl orange dye at 464 nm was observed. Figure 2-8 shows clearly the descent of the whole absorption spectra in time. The last two (the lowest two) absorption spectra were taken after the measurement. The second lowest absorption spectrum was measured after the  $\text{Cu}_2\text{O}$  powder suspended in methyl orange dye solution sank to the bottom of the beaker. It is seen that the dissolved  $\text{Cu}_2\text{O}$  powder affects the measured absorption spectra, but when the  $\text{Cu}_2\text{O}$  powder settles down, the purified solution of methyl orange is purer. The last absorption spectrum was taken after filtration of the residual  $\text{Cu}_2\text{O}$  powder.

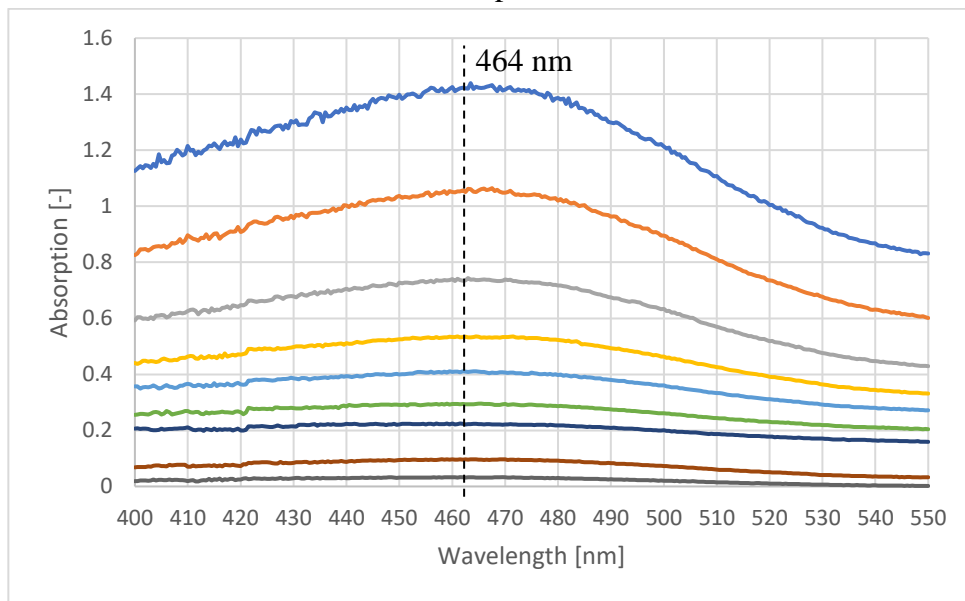

Figure 2-8 Absorption spectra of methyl orange dye with  $\text{Cu}_2\text{O}$  photocatalytic powder

A better presentation of the photocatalytic degradation of methyl orange is a degradation ratio. It is calculated from absorption data at 464 nm by following formula:

$$D = \frac{A_0 - A_t}{A_0} \cdot 100\% \quad (24)$$

Where  $A_0$  is the original absorption of methyl orange dye solution and  $A_T$  is the absorption of methyl orange dye after irradiation for a certain time. Table 2-2 shows the degradation data that were calculated from absorption data shown in Figure 2-8 at the wavelength of 464 nm.



Table 2-2 Calculated degradation data

Time [min]	0	30	60	90	120	150	180	Settled	Filtered
Absorption [-]	1.42	1.05	0.74	0.53	0.41	0.29	0.22	0.096	0.032
Degradation [%]	0	25.9	48.0	62.4	71.1	79.3	84.2	93.2	97.7



Figure 2-9 Methyl orange dye before (A) and after (B) photocatalytic degradation

### 2.3.3 Concentration of photocatalyst dependence

Photocatalytic reaction rate is highly dependent on concentration of used photocatalyst. As seen in Figure 2-10 this dependence should initially increase linearly with photocatalyst concentration, as depicted from point A to B. This initial linear behavior is due to the more absorbed photons. When transitioning from B to C, the maximum rate is reached and stays constant, which corresponds to the optimal light absorption. In some cases, the photocatalytic rate may decrease due to the reduced penetration depth of the incident light [27].

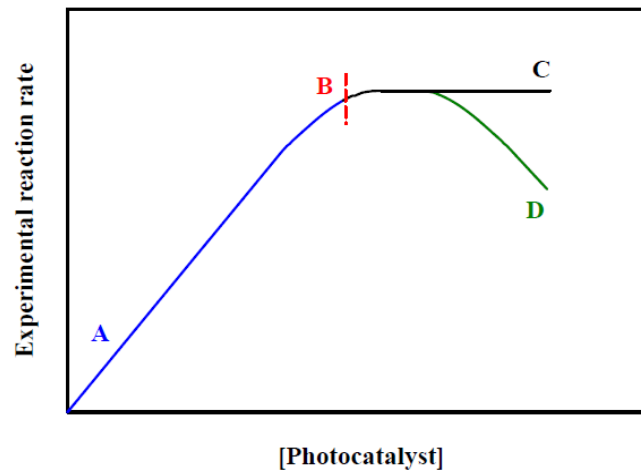

Figure 2-10 Experimental reaction rate of the photocatalyst vs. the concentration of a photocatalyst [27]

Measurement of degradation ratio dependence on concentration of photocatalyst confirms the theoretical reaction rate. Figure 2-11 shows the calculated degradation ratio values of four different concentrations of  $\text{Cu}_2\text{O}$  powder. As said in Hoque work [27] the experimental photocatalytic reaction rate should be linear. The measured dependence is

linear with lower concentrations of photocatalyst, and the logarithmic regression curve is being flattened at the higher concentrations of photocatalyst.

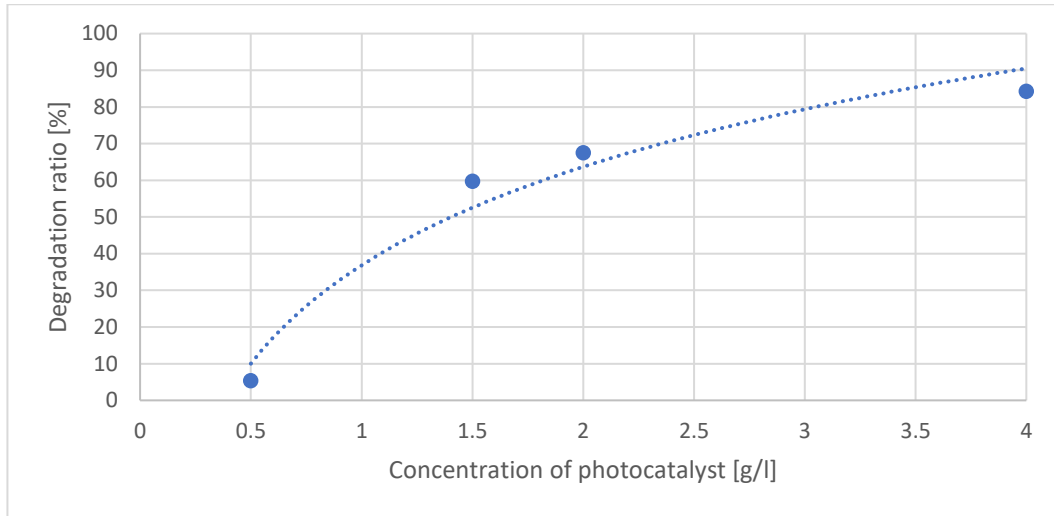

Figure 2-11 Degradation ratio dependence on concentration of  $\text{Cu}_2\text{O}$  photocatalyst

### 2.3.4 Recycling of photocatalyst

To prove the chemical stability of  $\text{Cu}_2\text{O}$  powder in water environment the same sample of powder was used 4 times. Every recycling cycle the absorption was measured and the degradation ratio was calculated.

The recycling cycle was composed of a few steps. After the initial measurement of photocatalytic activity, the used catalyst was filtered via glass sinter funnel and vacuum dried at  $85^\circ\text{C}$  for 3 hours. After the drying the photocatalytic measurement was repeated. This procedure was used for every recycling cycle.

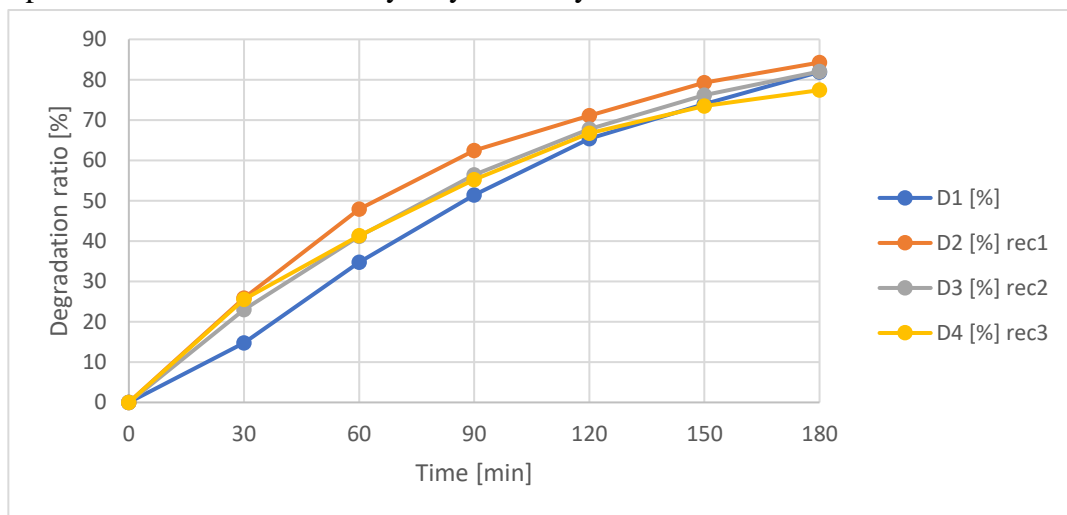

Figure 2-12 Recycling of  $\text{Cu}_2\text{O}$  powder

Figure 2-12 shows the degradation ratio of methyl orange dye with 3 recycling cycles of  $\text{Cu}_2\text{O}$  powder. It is clear that the first 3 measurements end with mostly same value of degradation ratio. The fourth cycle is starting to decrease the degradation ratio

of methyl orange dye. This measurement proves that the photocatalytic  $\text{Cu}_2\text{O}$  powder is very stable in water environment.

## 2.4 Photocatalytic system design

For more effective measurement of photocatalytic degradation of methyl orange dye, the photocatalytic system was designed. The photocatalytic system contains described photocatalytic chamber, lamp with fixed light spectrum, UV/vis spectrometer connected with the computer for later analysis, beaker with mixer that contains water solution of methyl orange dye and a pump that drives the analyzed water through the whole measurement system.

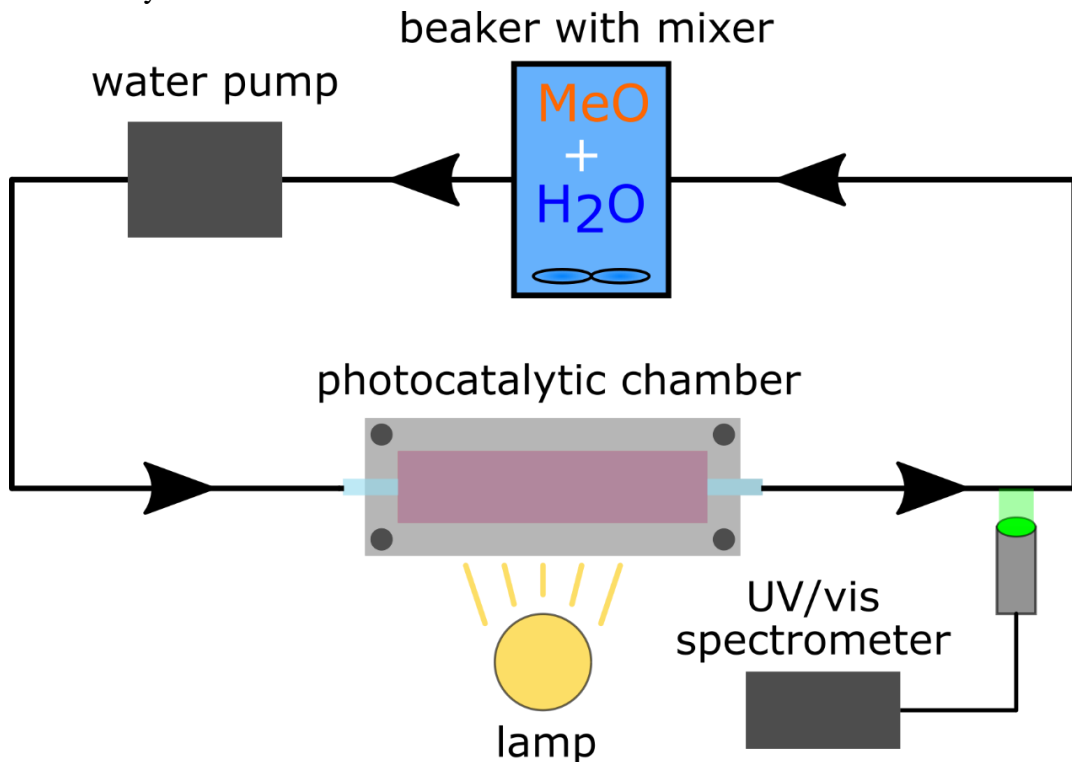

Figure 2-13 Photocatalytic system schematic

Photocatalytic chamber from Figure 2-13 is the most important part of the whole photocatalytic system. The photocatalytic chamber serves as the reactor for photocatalysis. This chamber holds substrate with the deposited layer of photocatalyst. The whole chamber consists of 3 parts: cover, gasket and the holder for the substrate. All of the parts were 3D printed. In Figure 2-14 the photocatalytic chamber is shown. The top part also holds a glass substrate that has to be transparent so the photons of light can react with the photocatalytic layer.

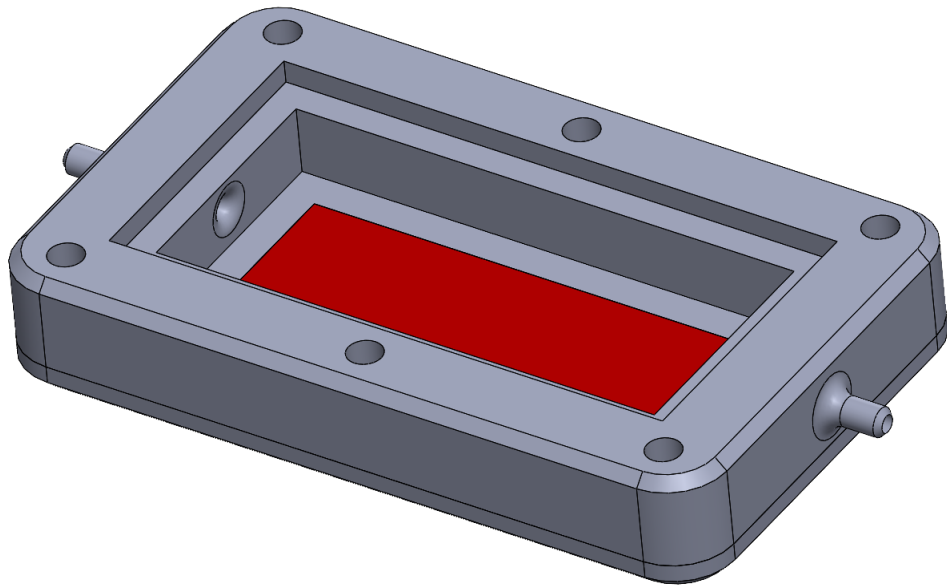

Figure 2-14 Photocatalytic chamber

This system was proven wrong after whole development as it is not large enough to achieve any reasonable high degradation ratio of methyl orange dye. The better method of deposition of photocatalytic material or enlargement of the photocatalytic chamber must be developed to achieve higher degradation ratio. The largest amount of photocatalyst for this photocatalytic system was still 10 times lower to show any significant degradation ratio results.

### 3. CONCLUSION

This thesis is divided into two parts. The first part of the thesis contains theoretical study of photocatalysis. The principle of photocatalysis is described with two main types of photocatalysis, homogeneous and heterogeneous. Heterogeneous photocatalysis is explained in more detail as it is the process that the metal oxide photocatalysts in further work use. In theoretical part of this thesis the applications of photocatalysts are represented. Those applications are water splitting, CO<sub>2</sub> reduction to fuel and photocatalytic water treatment. Water treatment application is described more explicitly because the practical part of this thesis is focused on photocatalytic organic pollutants degradation. Next section of theoretical part characterizes the environmental effects on photocatalytic properties of photocatalytic materials. At the end of the theoretical part, the properties of cuprous oxide as a photocatalyst are defined. The advantages of cuprous oxide in contrast to other copper oxides and titanium dioxide as the most used photocatalyst in the world are covered.

Section of the theoretical part that describes the photocatalytic properties of cuprous oxide also describes synthesis of cuprous oxide that is used in the first part of the practical part and experiments. The cuprous oxide used as the material of interest in this thesis was synthesized by reduction of cupric sulfate. As the reduction reagent an ascorbic acid was used. The synthesized cuprous oxide powder was very pure and good quality as the results of the conducted analysis show. XRD and EDX analysis confirms that the synthesized powder does not contain any impurities. SEM images of cuprous oxide powder show the morphology of the powder and with comparison to Tang et al. work [26] the synthesized cuprous oxide powder has the best morphology for organic pollutants degradation. The last used analysis was UV/vis spectroscopy and with this analysis the previous statement about high potential of organic pollutants degradation was proven. Results from UV/vis spectroscopy shows high degradation ratio of methyl orange dye. Methyl orange dye serves as a model to organic pollutants. The highest degradation ratio of methyl orange dye was at 97.7 %, which is comparable to the degradation ratio achieved by Zhang et al. [25] that uses the same synthesis method. UV/vis spectroscopy analysis also proved that the synthesized powder is very stable in water environment. After 4 cycles of use of same sample of cuprous oxide powder the degradation ratio decreased only about approximately 10 %.

Last section of this thesis was a brief introduction to photocatalytic system. This system was designed as an experimental equipment to an effective measurement of the photocatalytic degradation of methyl orange. Unfortunately, after the whole development of this equipment the use of the photocatalytic system was proven wrong. The designed system was not efficient enough to achieve any significant degradation ratio of methyl orange dye. The main problem was the deposition of cuprous oxide powder in the base of the reaction vessel. The amount of deposited photocatalyst was not high enough.

## LITERATURE

- [1] Thomas, J. M., Williams, R. J. P., “Catalysis: principles, progress, prospects,” *Philosophical Transactions of the Royal Society A: Mathematical, Physical and Engineering Sciences*, vol. 363, no. 1829, p. 765–791, 2005.
- [2] Catalysts Europe, “What are catalysts,” Catalysts Europe, Brussels, 2018.
- [3] Fujishima, A., Honda, K., “Electrochemical Photolysis of Water at a Semiconductor Electrode,” *Nature*, vol. 238, no. 5358, p. 37–38, 1972.
- [4] Serpone, N., Emeline, A. V., “Semiconductor Photocatalysis - Past, Present and Future Outlook,” *J. Phys. Chem. Lett.*, vol. 3, no. 5, pp. 673-677, 2012.
- [5] Max, L., Pichat, P., *Photocatalysis and Water Purification : From Fundamentals to Recent Applications*, John Wiley & Sons, Incorporated, 2013.
- [6] Beller, M., Renken, A., Santen, R. A. van, *Catalysis: From principles to applications*, Weinheim: Wiley-VCH, 2012.
- [7] Fenton, H. J. H., “Oxidation of tartaric acid in presence of iron,” *J. Chem. Soc.*, vol. 65, pp. 899-910, 1894.
- [8] Steven, S. L., *New and Future Developments in Catalysis : Solar Photocatalysis*, Elsevier, 2013.
- [9] Bauer, R., Waldner, G., Fallmann, H., Hager, S., Klare, M., Krutzler, T., Malato, S., Maletzky, P., “The photo-fenton reaction and the TiO<sub>2</sub>/UV process for waste water treatment - novel developments,” *Catalysis today*, vol. 53, pp. 131-144, 1999.
- [10] Chen, X., Shen, S., Guo, L. Mao, S. S., “Semiconductor-based Photocatalytic Hydrogen Generation,” *Chemical reviews*, vol. 110, no. 11, pp. 6503-6570, 2010.
- [11] Nakata, K., Fujishima, A., “TiO<sub>2</sub> photocatalysis: Design and applications,” *Journal of Photochemistry and Photobiology C: Photochemistry Reviews*, vol. 13, no. 3, pp. 169-189, 2012.
- [12] Guo, J., X. Chen, *Solar hydrogen generation: transition metal oxides in water photoelectrolysis*, New York: McGraw-Hill, 2012.
- [13] Zaleska-Medynska, A., *Metal Oxide-Based Photocatalysis: Fundamentals and Prospects for Application*, Elsevier, 2018.
- [14] Oluwafunmilola, O., Maroto-Valer, M. M., “Review of material design and reactor engineering on TiO<sub>2</sub> photocatalysis for CO<sub>2</sub> reduction,”

*Journal of Photochemistry and Photobiology C: Photochemistry Reviews*, vol. 24, pp. 16-42, 2015.

- [15] Li, K., Peng, B., Peng, T., “Recent Advances in Heterogeneous Photocatalytic CO<sub>2</sub> Conversion,” *ACS Catalysis*, vol. 6, no. 11, pp. 7485-7527, 2016.
- [16] Saiqa, I., *Photocatalysis: Perspective, Mechanism, and Applications*, Nova Science Publishers Incorporated, 2019.
- [17] Pawar, R., Lee, C. S., *Heterogeneous Nanocomposite-Photocatalysis for Water Purification*, Elsevier Science & Technology Books, 2015.
- [18] Hoffmann, M. R., Martin, S. T., Choi, W., Bahnemann, D. W., “Environmental applications of semiconductor photocatalysis,” *Chemical Reviews*, vol. 95, no. 1, pp. 69-96, 1995.
- [19] Herrmann, J. M. , “Heterogeneous photocatalysis: state of the art and present applications,” *Topics in Catalysis*, vol. 34, no. 1-4, pp. 49-65, 2005.
- [20] Malato, S., Fernández-Ibáñez, P., Maldonado, M. I., Blanco, J., Gernjak, W., “Decontamination and disinfection of water by solar photocatalysis: Recent overview and trends,” *Catalysis Today*, vol. 147, no. 1, p. 1–59, 2009.
- [21] Yang, H., Ouyang, J., Tang, A., Xiao, Y., Li, X., Dong, X., Yu, Y., “Electrochemical synthesis and photocatalytic property of cuprous oxide nanoparticles,” *Materials Research Bulletin*, vol. 41, no. 7, p. 1310–1318, 2006.
- [22] Šmatlo, F., “Cuprous oxide as a semiconductor photocatalyst used for organic pollutants degradation,” in *Proceedings of the 27tg Conference STUDENT EEICT 2021; Accepted for publication*, Brno, 2021.
- [23] Beverskog, B., Puigdomenech, I., *Revised Pourbaix diagrams of copper at 5-150 °C*, Stockholm: Gotab, 1995.
- [24] Korzhavyi, P. A., Soroka, I. L., Isaev, E. I., Lilja, Ch., Johansson, B., “Exploring monovalent copper compounds,” *PNAS*, vol. 109, no. 3, pp. 686-689, 2012.
- [25] Zhang, X., Song, J., Jiao, J., Mei, X., “Preparation and photocatalytic activity of cuprous oxides,” *Solid State Sciences*, vol. 12, no. 7, p. 1215–1219, 2010.
- [26] Tang, L., Lv, J., Sun, S., Zhang, X., Kong, Ch., Song, X., Yang, Z., “Facile hydroxyl-assisted synthesis of morfological Cu<sub>2</sub>O architectures and their shape-dependent photocatalytic performances,” *New J. Chem.*, vol. 38, pp. 4656-4660, 2014.

- [27] Hoque, A., Guzman, M. I., “Photocatalytic Activity: Experimental Features to Report in Heterogeneous Photocatalysis,” *MDPI Materials* 2018, vol. 11, no. 10, p. 1990, 2018.
- [28] Kisch, H. , *Semiconductor Photocatalysis : Principles and Applications*, John Wiley & Sons, Incorporated, 2015.



# SYMBOLS AND ABBREVIATIONS

## Abbreviations:

CB	Conduction Band
VB	Valence Band
NHE	Normal Hydrogen Electrode
XRD	X-ray Powder Diffraction
EDX	Energy-Dispersive X-ray Spectroscopy
SEM	Scanning Electron Microscope
LED	Light-Emitting Diode

## Symbols:

$D$	degradation ratio	(%)
$A_0$	original absorption	(-)
$A_T$	absorption after certain time	(-)