



BRNO UNIVERSITY OF TECHNOLOGY

VYSOKÉ UČENÍ TECHNICKÉ V BRNĚ

FACULTY OF ELECTRICAL ENGINEERING AND COMMUNICATION

FAKULTA ELEKTROTECHNIKY
A KOMUNIKAČNÍCH TECHNOLOGIÍ

DEPARTMENT OF FOREIGN LANGUAGES

ÚSTAV JAZYKŮ

DESIGN OF A TOPOLOGY OF A DISTRIBUTED CONTROL SYSTEM FOR HOME AUTOMATION USING IoT TECHNOLOGIES

NÁVRH TOPOLOGIE DISTRIBUOVANÉHO ŘÍDÍCÍHO SYSTÉMU
PRO DOMÁCI AUTOMATIZACI VYUŽÍVAJÍCÍHO TECHNOLOGIE IoT

BACHELOR'S THESIS

BAKALÁŘSKÁ PRÁCE

AUTHOR

AUTOR PRÁCE

Jakub Mokrejš

SUPERVISOR

VEDOUCÍ PRÁCE

Mgr. Ing. Eva Ellederová, Ph.D.

BRNO 2021

Bakalářská práce

bakalářský studijní program **Angličtina v elektrotechnice a informatice**

Ústav jazyků

Student: Jakub Mokrejš

ID: 211297

Ročník: 3

Akademický rok: 2020/21

NÁZEV TÉMATU:

Návrh topologie distribuovaného řídicího systému pro domácí automatizaci využívajícího technologie IoT

POKYNY PRO VYPRACOVÁNÍ:

Navrhněte topologii distribuovaného řídicího systému pro domácí automatizaci využívajícího technologie IoT, definujte jeho prvky a zvolte pro ně vhodné IoT technologie.

DOPORUČENÁ LITERATURA:

- 1) Kyas, O. (2017). How to smart home. Wyk auf Föhr: Key Concept Press.
- 2) Cheng, J., & Kunz, T. (2009). A survey on smart home networking. Ottawa: Carleton University.
- 3) Ismail, Y. (2019). Internet of Things (IoT) for automated and smart applications. London: IntechOpen.
- 4) Greengard, S. (2015). The Internet of Things. Cambridge: The MIT Press.
- 5) Patrick, J. R. (2017). Home attitude: Everything you need to know to make your home smart. Scotts Valley: CreateSpace.

Termín zadání: 31. 1. 2021

Termín odevzdání: 31. 5. 2021

Vedoucí práce: Mgr. Ing. Eva Ellederová, Ph. D.

Konzultant: Ing. Ondřej Baštán

Doc. PhDr. Milena Krhutová, Ph.D.
předseda oborové rady

UPOZORNĚNÍ:

Autor semestrální práce nesmí při vytváření semestrální práce porušit autorská práva třetích osob, zejména nesmí zasahovat nedovoleným způsobem do cizích autorských práv osobnostních a musí si být plně vědom následků porušení ustanovení § 11 a následujících autorského zákona č.121/2000 Sb., včetně možných trestněprávních důsledků vyplývajících z ustanovení části druhé, hlavy VI. díl 4 Trestního zákoníku č. 40/2009 Sb.

Fakulta elektrotechniky a komunikačních technologií, Vysoké učení technické v Brně / Technická 3058/10 / 616 00 / Brno

Abstract

This bachelor's thesis frames the concept of the Internet of Things, a smart home and a distributed control system, provides a survey of communication protocols and smart home services, and consequently discusses the author's own design of a smart home topology. The thesis first describes the Internet of Things and its practical applications. Then, it focuses on a smart home, especially on networks and topologies used there. Next, networks and topologies are analysed and compared concerning their use, advantages and disadvantages. Characteristic features of the distributed control system follow including a survey of different communication protocols. The description of services and smart home components concludes the theoretical part of the thesis. The practical part of the thesis deals with the author's own design of a topology and components for a smart home. Finally, the designed topology is compared with other topologies.

Key words

Smart home, Internet of Things, network topologies, distributed control system, communication protocols, network, Google

Abstrakt

Bakalářská práce vymezuje koncepci internetu věcí, chytré domácnosti a distribuovaného řídicího systému, poskytuje přehled komunikačních protokolů a služeb chytré domácnosti a následně diskutuje autorův vlastní návrh topologie chytré domácnosti. Práce nejdříve popisuje internet věcí a oblasti, ve kterých se využívá. Poté se práce zaměřuje na chytrou domácnost, a to konkrétně na sítě a topologie, které v ní mohou být použity. Dále je provedena analýza a srovnání sítí a topologií s ohledem na jejich použití, výhody a nevýhody. Následuje popis distribuovaného kontrolního systému a na to navazující přehled komunikačních protokolů. Popis služeb a prvků chytré domácnosti uzavírá teoretickou část práce. Praktická část práce se zaměřuje na návrh vlastní topologie a prvků pro chytrou domácnost. Práce je zakončena porovnáním vytvořené topologie s ostatními topologiemi.

Klíčová slova

Chytrá domácnost, internet věcí, topologie sítí, distribuovaný řídicí systém, komunikační protokoly, Google

Rozšířený abstrakt

Bakalářská práce *Design of a Topology of a Distributed Control System for Home Automation Using IoT Technologies* má za úkol provést rešerši literatury v oblasti řídicích systémů a zjistit, jaké nemodernější prvky se používají v domácí automatizaci využívající technologie internetu věcí (Internet of Things/IoT) a porovnat jejich klíčové parametry. Hlavním cílem bakalářské práce je navrhnout topologii distribuovaného řídicího systému pro domácí automatizaci, která využívá IoT technologii, definovat jednotlivé prvky systému a zvolit pro ně vhodnou IoT technologii. Dílčím cílem práce je dále navrženou topologii porovnat s ostatními topologiemi, které se momentálně využívají a vyhodnotit výsledky návrhu.

Teoretická část práce se skládá z osmi kapitol. Práce začíná úvodní kapitolou, ve které je popsána a vysvětlena koncepce IoT, jeho fungování a oblasti využití. Druhá kapitola definuje pojem chytrá domácnost a vymezuje její pojetí z pohledu různých autorů. Další kapitola se zabývá topologiemi sítí, které je možné využít v chytré domácnosti. V této kapitole je podrobně popsáno pět sítí, od nejmenší, tzv. síť oblasti těla či Body Area Network (BAN), po největší, tzv. rozlehlou počítačovou síť či Wide Area Network (WAN). Každá síť je popsána vzhledem k její funkci a využití. Čtvrtá kapitola se zabývá topologiemi, které se používají v chytré domácnosti. Stejně jako v předchozí kapitole i v této je každá topologie popsána vzhledem k její funkci a využití. Pátá kapitola vysvětluje distribuovaný řídicí systém, který bude využit v praktické části, a uvádí jeho výhody a nevýhody. Další kapitola, která se zabývá komunikačními protokoly, je rozdělena do dvou podkapitol popisujících bezdrátové a drátové komunikační protokoly. U každého protokolu jsou zmíněny jeho funkce, výhody, nevýhody a využití. Sedmá kapitola popisuje služby, které nabízí chytrá domácnost a jaké zařízení jsou potřeba k jejich využití. Následující osmá kapitola je poslední z teoretické části a čtenář se v ní dozví, jaké prvky jsou nutné pro chod chytré domácnosti.

Teoretická část je založena na rešerši odborných knih, článků, výzkumných zpráv, manuálů a blogů zabývajících se tématem chytré domácnosti. Při rešerši dostupné literatury bylo potřeba vybírat zdroje podle toho, zda jsou stále relevantní. Koncepce chytré domácnosti, jejích prvků a aplikací podléhá rychlému vývoji. Z toho důvodu nelze články, které byly publikovány před deseti lety, považovat v současnosti za relevantní. Většina zdrojů byla tedy vybrána tak, aby byly co nejaktuálnější a odpovídaly momentálním trendům v oblasti chytré domácnosti.

Praktická část práce je zaměřena na vlastní návrh topologie chytré domácnosti a je rozdělena do dvou kapitol. První kapitola vymezuje znalosti a informace, které jsou nezbytné před tím, než je zahájena implementace jednotlivých prvků chytré domácnosti. Následující podkapitola popisuje vybavenost a funkce bytu, do kterého bude chytrá domácnost zaváděna včetně ilustrace půdorysu bytu s tabulkou označující jednotlivé místnosti. Dále kapitola pokračuje popisem funkcí, které budou v jednotlivých místnostech požadovány. Další podkapitola představuje navrženou topologii a popisuje její funkce a výhody a také porovnává navrženou topologii s topologií, kterou využívají zařízení Google. Poslední podkapitola popisuje požadavky na jednotlivá zařízení, která se využívají v topologii a dává příklady zařízení, která tyto požadavky splňují. Druhá kapitola praktické části práce porovnává navrženou topologii s jinými topologiemi a diskutuje jejich výhody a nevýhody.

Rešerše literatury pro praktickou část bakalářské práce zahrnuje odborné články, knihy, video recenze a video tutoriály nejen k jednotlivým produktům, ale i k samotnému procesu návrhu funkční chytré domácnosti. Chytrá domácnost a celé její odvětví je momentálně ve velkém rozmachu, což potvrzuje hlavně nabídka produktů a jejich kompatibilita mezi sebou.

Praktická část této práce se proto zaměřuje na vytvoření topologie využívající distribuovaný systém řízení tak, aby při poruše jednoho centrálního zařízení nedošlo k výpadku všech zařízení. Díky této topologii lze tedy ovládat zařízení v místnosti s poškozeným centrálním zařízením pro ovládání i z jiné místnosti v bytě. Tato topologie je tak vhodná i pro zařízení, která nejsou tak spolehlivá a zároveň levná, protože při poruše jednoho zařízení nedojde ke kolapsu celé sítě. Momentálně ale není na trhu takové centrální zařízení, které by dokázalo splnit všechny požadavky, které tato topologie vyžaduje. Proto je návrh tohoto zařízení zajímavou výzvou do budoucna.

Mokrejš, J. (2021). *Návrh topologie distribuovaného řídicího systému pro domácí automatizaci využívajícího technologie IoT*. Brno: Vysoké učení technické v Brně, Fakulta elektrotechniky a komunikačních technologií. 55 s.

Vedoucí bakalářské práce: Mgr. Ing. Eva Ellederová, Ph.D.

Prohlášení

Prohlašuji, že bakalářskou práci na téma *Návrh topologie distribuovaného řídicího systému pro domácí automatizaci využívajícího technologie IoT* jsem vypracoval samostatně pod vedením vedoucí bakalářské práce a s použitím odborné literatury a dalších informačních zdrojů, které jsou všechny citovány v práci a uvedeny v seznamu literatury na konci práce.

Jako autor uvedené bakalářské práce dále prohlašuji, že v souvislosti s vytvořením této práce jsem neporušil autorská práva třetích osob, zejména jsem nezasáhl nedovoleným způsobem do cizích autorských práv osobnostních a/nebo majetkových a jsem si plně vědom následků porušení ustanovení § 11 a následujících zákona č. 121/2000 Sb., o právu autorském, o právech souvisejících s právem autorským a o změně některých zákonů (autorský zákon), ve znění pozdějších předpisů, včetně možných trestněprávních důsledků vyplývajících z ustanovení části druhé, hlavy VI. díl 4 Trestního zákoníku č. 40/2009 Sb.

V Brně dne 25.5. 2021

.....

Jakub Mokrejš

Acknowledgements

I wish to express my sincere gratitude to my supervisor Mgr. Ing. Eva Ellederová Ph.D. for providing me with the necessary help, supervision, valuable comments and, last but not least, patience throughout writing this thesis.

Table of Contents

Introduction	11
THEORETICAL PART	
1 Internet of Things (IoT)	12
1.1 Examples of Internet of Things applications	13
1.1.1 Transportation.....	13
1.1.2. Health care	14
1.1.3. Energy management	15
2 Smart home concept.....	16
3 Area networks used in a smart home	18
3.1 Body area network (BAN).....	18
3.2 Personal area network (PAN).....	19
3.3 Home area network (HAN)	20
3.4 Local area network (LAN)	21
3.5 Bigger area networks	22
4 Topologies used in home automation	24
4.1 Bus topology.....	24
4.2 Ring topology	25
4.3 Star topology	26
4.4 Mesh topology	26
4.5 Hybrid topology.....	27
5 Distributed control system.....	28
6 Communication	30
6.1 Wired communication protocols	30
6.2 Wireless communication protocols	33
7 Smart home services	38
7.1 Home conditions measurement	38
7.2 Smart home security	38
7.3 Home appliances management	39
7.3.1 Digital personal assistant	39
8 Smart home components	40

PRACTICAL PART

9 Design of a smart home.....	41
9.1 Layout and equipment of the household and requirements for a smart solution ...	41
9.2 Topology design	45
9.3 Device requirements	46
9.3.1 Motor for retracting blinds	46
9.3.2 Smart bulbs	46
9.3.2.1 Smart plug.....	46
9.3.3 Motion sensor	47
9.3.4 Smoke detector	47
9.3.5 Ventilation	47
9.3.6 Door sensor.....	47
9.3.7 Central control device.....	47
10 Comparison with other topologies	49
Conclusion.....	50
List of references	51
List of figures	55
List of tables.....	55

Introduction

Smart homes have become very widespread and popular in recent years thanks to their functionality and the way they can make people's lives easier. The Internet of Things (IoT) is an integral part of everything "smart" and smart homes are not an exception. For this reason, the objective of this bachelor's thesis is to review the current state of the art of smart homes technology and to develop the optimal design solution for a smart home using the IoT.

The thesis consists of two parts, theoretical and practical, divided into ten chapters. The first chapter deals with the IoT and its functionality in different areas. Smart environments and applications are discussed for a better understanding of the IoT concept. The second chapter describes the concept of a smart home, the history of the first smart devices and how the understanding of a smart home has changed. The third chapter describes area networks that can be used in a smart home and divides them into groups according to their size (from LAN do WAN). Each network is described with respect to its functionality, advantages and disadvantages. The fourth chapter presents topologies that can be used in a smart home. Five topologies are depicted and described in the same way as area networks in the third chapter. The fifth chapter describes a distributed control system including its advantages and disadvantages. The sixth chapter in this thesis deals with wired and wireless communication protocols that can be used in a smart home. The seventh chapter summarizes the services that a smart home offers in its four subchapters. Functions and an implementation process of each service are described and explained here. The eighth chapter names and describes the components that are essential for a smart home.

The ninth chapter, which belongs to the practical part of the thesis, deals with the design of a topology of a distributed control system using IoT technologies. It explains where the smart home will be implemented, the properties of the household, functions and devices requirements and products that are suitable for use. A floor plan, layout of the products that are suitable for use and picture of designed topology are included as well. The tenth and last chapter compares the designed topology with other topologies and discusses their advantages and disadvantages.

THEORETICAL PART

1 Internet of Things (IoT)

Mocrii, Chen and Musilek (2018) comment that if a device is interconnected with other devices, it becomes more useful. The IoT is not just a bunch of devices and sensors which are interconnected by wire or wirelessly – it is “a dense integration of the virtual and the real world, where the communication between people and devices takes place” (Mocrii et al., 2018, p. 81).

Domb (2019) defines the IoT as follows:

The internet of things (IoT) paradigm refers to devices connected to the Internet. Devices are objects such as sensors and actuators, equipped with a telecommunication interface, a processing unit, limited storage and software applications. It enables the integration of objects into the Internet, establishing the interaction between people and devices among devices. (p. 24)

Ismail (2019) explains that the main difference between the IoT and the Internet is that the IoT can create information about the connected device, analyse it, and make decisions. In other words, the IoT is smarter than the Internet. According to Vermesan (2013), the IoT is a concept that considers pervasive presence in the environment of a variety of objects or things that through unique addressing schemes, wireless and wired connections are able to communicate with each other and work together to create new services and achieve common goals (see Figure 1). These smart systems surround, support, and sustain people in homes, schools, offices, supermarkets, restaurants, hospitals, gyms, airports, and other vital connection points. As Raj and Raman (2017) point out, they “seamlessly connect, collaborate, corroborate, and correlate to understand our mental, social, and physical needs and deliver them in a highly unobtrusive, secure, and relaxed fashion” (p. 3).

The IoT is a revolution of the Internet since all smart devices can recognize each other, and they gain intelligence by making or providing context-related decisions thanks to the fact that they are able to communicate data. Vermesan (2013) also adds that the main aim of the IoT is to allow things to connect whenever wherever and with anything and anyone if possible, using any service and any path/network. The IoT leads to smarter computing, provides smarter environments, and fulfils personal as well as professional requirements instantly and instinctively. The following chapters focus on the crucial IoT application domains.



Figure 1. IoT in the context of smart environments and applications.
Reprinted from Vermesan (2013, p. 24)

1.1 Examples of Internet of Things applications

1.1.1 Transportation

Krishnamohan and Reddy (2018) report that application of the IoT extends to all elements of transportation systems, as shown in Figure 2. Active cooperation between these elements of the transport system allows inner and outer vehicular communication, traffic control, smart parking, safety, and road assistance. Collision detection, lane change warning, traffic signal control are essential aspects of road safety systems that are provided by sensors in automobiles which connects through control systems to the Internet (Krishnamohan & Reddy, 2018).



Figure 2. Application of the IoT in transportation.
 Reprinted from Krishnamohan and Reddy (2018, p.2).

1.1.2 Health Care

According to Krishnamohan and Reddy (2018), health care is an essential industry with enormous potential. There are many specific devices for measuring and managing several health parameters of humans. If a health reading device records some abnormality, it is even able to remind the patient and their family as well as the doctor if there is an emergency. This process is illustrated in Figure 3 (Krishnamohan & Reddy, 2018). Raj and Raman (2017) add that some hospitals are equipped with smart beds that can detect if the patient is lying or if he is attempting to get up.



Figure 3. Smart healthcare.

Reprinted from <https://yourstory.com/2018/07/digital-healthcare-palm-hand-smart-idea>

1.1.3 Energy management

Krishnamohan and Reddy (2018) expect the integration of sensors and actuators that are connected to the Internet and optimize energy consumption. They also anticipate that these IoT devices will be implemented into all forms of energy-consuming devices and able to cooperate with power generation.

As you can see in Figure 1, the IoT can be implemented in different spheres of our lives. Each of them is interesting, and it improves or makes our lives easier to a certain extent. One of these spheres is a smart building or a smart home. Chapter 2 frames the concept of the smart home and its relation to the IoT.

2 Smart home concept

Hendricks (2014) states that “although the idea of home automation has been around for some time, actual smart homes have only existed a short while” and describes hardware inventions that lead up to “the smart homes we know today”.

According to Sinha (2018), the first home appliances such as a vacuum cleaner and a refrigerator were a game-changer for the people of the 20th century, even though they were not “smart” appliances. The first smart device was the ECHO IV that could compute a shopping list, turn appliances on and off, and control home temperature, although it was never commercially sold (Hendricks, 2014). The next device was the Kitchen Computer which could create and store recipes, but its price caused the failure. A concept called “Gerontechnology”, which is a combination of gerontology and technology, is aimed at senior citizens and makes their lives easier (Sinha, 2018). In the early 2000s, smart homes and home automation began to increase in popularity, a different technology emerged, and smart homes became more affordable.

Smart homes have changed since then and, as i-SCOOP (n.d.) rightly points out, “smart homes can mean many different things to many different people” and “the concept is evolving as home automation in the classic sense meets an increasing range of products”. According to Kyas (2017), “smart home technologies have become a central component of larger Internet of Things concepts such as smart cities, smart industry or smart grids” (p. 30). Although a smart home can mean different things to many people, Chen (2020) frames its concept as follows:

A smart home refers to a convenient home setup where appliances and devices can be automatically controlled remotely from anywhere with an internet connection using a mobile or other networked device. Devices in a smart home are interconnected through the Internet, allowing the user to control functions such as security access to the home, temperature, lighting, and a home theatre remotely.

Kim (2016) notes that a smart home is “a technology that can connect everything to networks to monitor and control them in various areas such as home appliances, energy-consuming devices, and security devices” (p. 24). Sinha (2018) adds that people are more aware of the

capability of technologies that enables the user to save energy by light control, window covering and irrigation.

Sinha (2018) highlights that “smart homes are more about living greener and providing security”. Smart home technology is currently being incorporated into other sectors, and the market expects increased demand for this technology in the coming years due to expanding awareness about the advantages of a smart home.

Kim (2016) mentions that a smart home contains a wired or wireless network, smart devices, the IoT communication standard, control devices, and an operational platform. Kim (2016) also divides smart devices that can be used in a smart home into two categories. The first is comprised of home appliances with Internet communication functions such as TV, refrigerator, and washing machine. The second category includes CCTV, security, energy, heat and health devices that support smart functions (Kim, 2016).

For these smart devices to be able to communicate and give the owner the necessary information, it is essential to integrate them into the network. The following chapter describes the networks that are used to connect devices not only in the house but also outside it.

3 Area networks used in a smart home

Area networks in a smart home and home automation fulfil two needs. The first one is that they make communication of the equipment inside the house possible and the second one is that they connect the Internet world outside with the smart home. On this basis, Ricquebourgh et al. (2006) divide networks into these groups:

- body area network (BAN)
- personal area network (PAN)
- local area network (LAN)
- bigger area networks

Each network has its usage; the following chapters describe each network in terms of functions, use, advantages and disadvantages.

3.1 Body area network (BAN)

Gupta, Mukherjee and Venkatasubramanian (2013) describe that a body area network (BAN) consists of a heterogeneous set of nodes that can sense, actuate, compute, and communicate between each other via a multi-hop wireless channel. A BAN picks, processes, and saves parameters from the host's body and its surroundings; and can actuate treatments such as drug delivery thanks to the data that is collected. Gupta et al. (2013) define the following parameters that can be monitored by a BAN:

- physiological parameters – blood pressure, electrocardiogram;
- activity parameters – running, walking, sleeping;
- environmental parameters – outside temperature, humidity, and presence of allergens in surroundings.

Etsi (2020) points out that the sensors can be carried even inside the body and adds that these sensors also fulfil part of personal safety – such as fall detection¹.

¹ Fall detection devices refer to the technology that detects and gets fast assistance for a person (usually a senior) that is prone to falls. A fall detection medical alert system allows the user to summon help without having to press the call button. These systems automatically activate the sensor if the user suffers a fall. The built-in technology can be worn around the neck or, depending on the device, on your wrist or on your waist (GreatCall, 2020).

According to Gupta et al. (2013), a BAN is composed of two types of computing units as you can see in Figure 4. The first are sensor nodes, which processing capability is low; and the second is a base station that is represented by a high-end device such as PDA or cell-phone. Units communicate with each other through a wireless channel because wires in a BAN would make it obtrusive. Communication is expected to be reliable, and each sensor should be time-synchronized through several schemes based on packet-arrival time (Gupta et al., 2013).

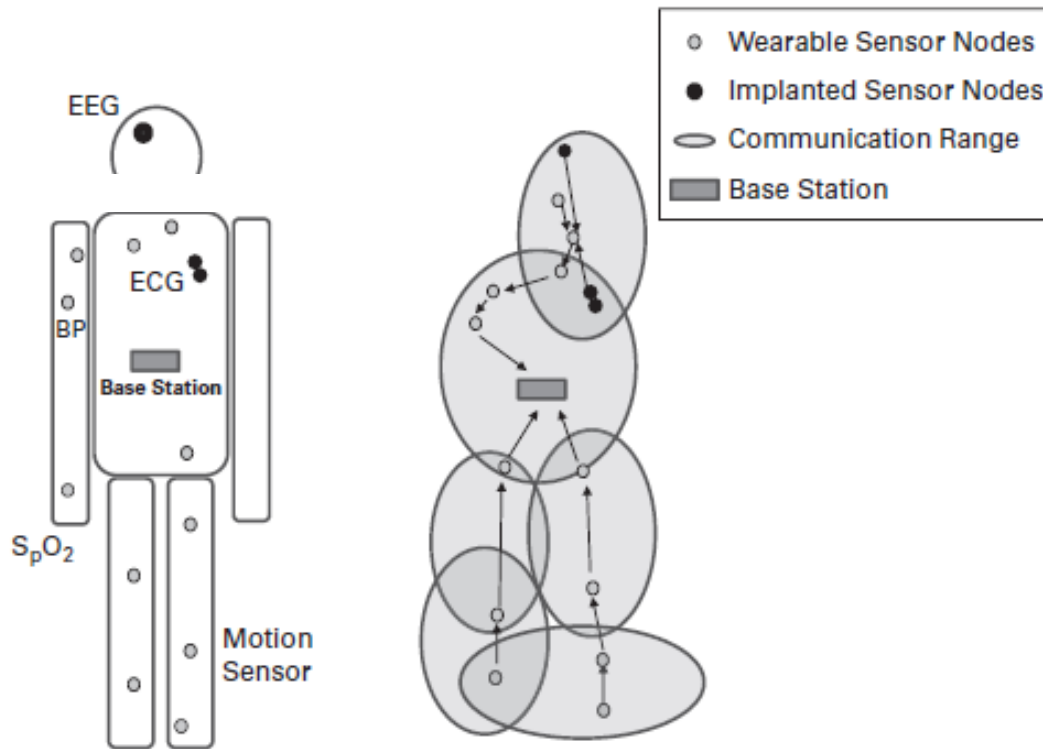

Figure 4. A body area network. Reprinted from Gupta et al. (2013 p. 12).

3.2 Personal area network (PAN)

As Sadiku, Tembley and Musa (2017a) note, a personal area network (PAN) “connects IT devices or gadgets within the environment of an individual user (such as cell phones, personal computers, laptop computers, PDAs, printers, pagers, or other wearable computer devices)” (p. 628). They then add that a PAN has received a lot of attention in recent years because it enables low-power and low-rate communication between the devices close to the user.

Sadiku et al. (2017a) also mention that devices in a PAN should draw little current and are located within 1 m to 100 m each other. A typical range of this network is a few meters. Two

types of personal area networks depend on connection – a wireless PAN and a wired PAN (Jena, 2020a).

Sadiku et al. (2017a) report that a wireless PAN or a WPAN uses these wireless technologies – infrared, ZigBee and Bluetooth. A WPAN not only allows connection to the Internet but also connects devices as keyboards, audio headsets and printers to personal digital assistants, computers and cell phones wirelessly. According to Sadiku et al. (2017a), a PAN is frequently used in medicine. They also emphasize its application in the telemedical environment and intelligent control of medication delivery because of its wireless sensing. It can serve as an aid for disabled people too.

3.3 Home area network (HAN)

According to Jena (2020b), a home area network (HAN) is a network in a user's home where all the devices and smart appliances are connected to a network. Sadiku et al. (2017b) add that this network should also be used in small offices. They then mention devices like televisions, computers, printers, home security systems and smart appliances.

A HAN makes communication and operations between the digital devices easier and enhances home security. It also allows a standard Internet connection and sharing resources (shown in Figure 5). A HAN technology enables control and connects many digital devices within the house (Sadiku et al., 2017b). Jena (2020b) describes similarity with a PAN in terms of connectivity which can be either wireless or wired. Sadiku et al. (2017) report that a coaxial cable, PLC (powerline communications) or optical fibre is used as means of wired communication. Newer wireless technologies that are used and preferred in a HAN include Wi-Fi, Bluetooth and ZigBee due to their easy installation and reliability. The most significant advantage of wireless technology is remote control and monitoring (Sadiku et al., 2017b).

Sadiku et al. (2017b) describe four typical components of a HAN. The first element is a gateway which connects outside networks like a LAN and WAN to a HAN; the next is the access point followed by a network operating system; the last element is smart endpoints such as refrigerators, smart meters, and appliances.

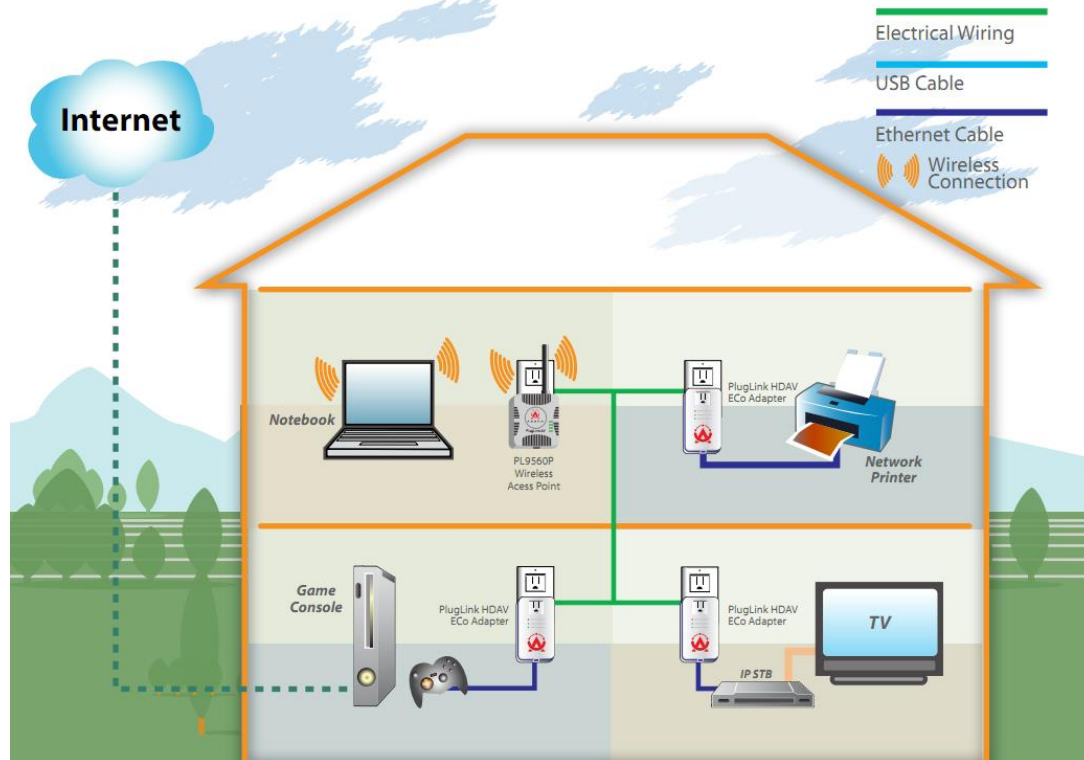

Figure 5. Example of a home area network. Reprinted from www.askotech.com.

3.4 Local area network (LAN)

Ricquebourgh et al. (2006) state that local area networks “serve the personal needs for an individual who is responsible to manage his own network” (p. 3). According to Cisco (n.d.), a local area network is a group of gadgets in a building, office, or home that are collectively connected. The size of a LAN ranges from one user on a home network to a company network that has thousands of users and devices. Tanenbaum & Wetherall (2010) explain that when a company uses a LAN, it is called an enterprise network. They also remark that a wireless LAN is very popular nowadays in homes, cafeterias and places where there is a problem to install cables. The most common solution is that each computer communicates with an access point, a base station, or a wireless router. These devices transmit packets not only between them and the Internet but also between the wireless computers. The popular standard for a wireless LANs is Wi-Fi (IEEE 802.11²) which has become very widespread. Speed of this standard is anywhere

² IEEE 802.11 is part of the IEEE 802 set of local area network (LAN) protocols which specifies the set of media access control (MAC) and physical layer (PHY) protocols for implementing wireless local area network (WLAN) Wi-Fi computer communication in various frequencies, including but not limited to 2.4 GHz, 5 GHz, 6 GHz, and 60 GHz frequency bands (IEEE, 2016).

from 11 to hundreds of Mbps (Tanenbaum & Wetherall, 2010).

Tanenbaum & Wetherall (2010) further write about transmission technologies of a wired LAN. Cooper wires use most, but the optical fibre is becoming more and more popular. Its speed is from 100 Mbps to 1 Gbps, but a newer LAN can operate up to 10 Gbps. The main advantage is that it has a lower delay and makes very few errors. By far, the most common type of a wired LAN is Ethernet (IEEE 802.3). Figure 6 displays an example of a switched Ethernet topology (b), where “each computer speaks the Ethernet protocol and connects to a box called a switch with a point-to-point link” (Tanenbaum & Wetherall, 2010, p. 20). They then add that purpose of the switch is to transfer packets between connected computers. Each packet has its address that determines which computer to send to.

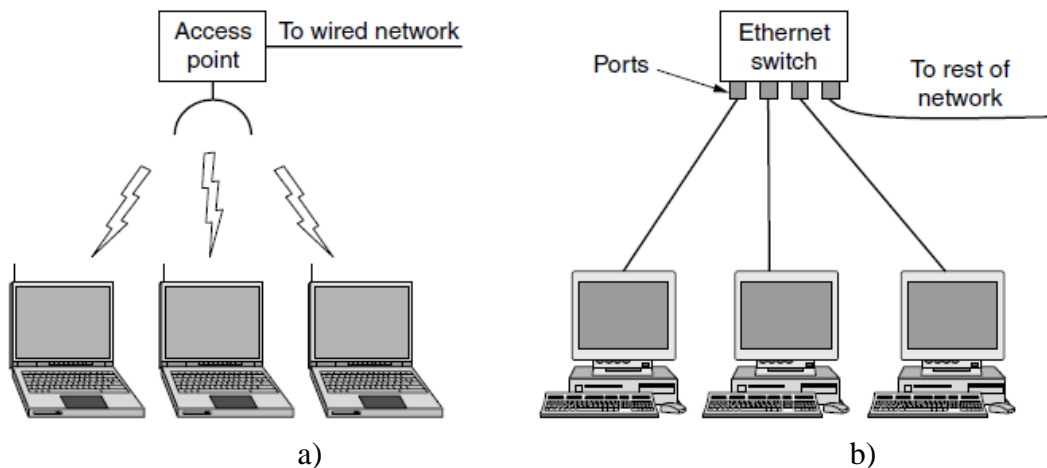

Figure 6. a) Example of a wireless LAN, b) Example of a wired LAN.
Reprinted from Tanenbaum and Wetherall (2010, p. 20).

3.5 Bigger area networks

A metropolitan area network (MAN) and a wide area network (WAN) belong to this group. As Goyal (2019) notes, a MAN “covers a larger area than that of a LAN and a smaller area as compared to a WAN. It connects two or more computers that are apart but resides in the same or different cities”. He also adds that a MAN has high-speed connectivity. According to Tanenbaum & Wetherall (2010), a MAN covers the city, and cable television networks are the best-known examples of it. A MAN can also provide a two-way Internet connection. In Figure 7, we can see a television signal and Internet distribution to people’s homes.

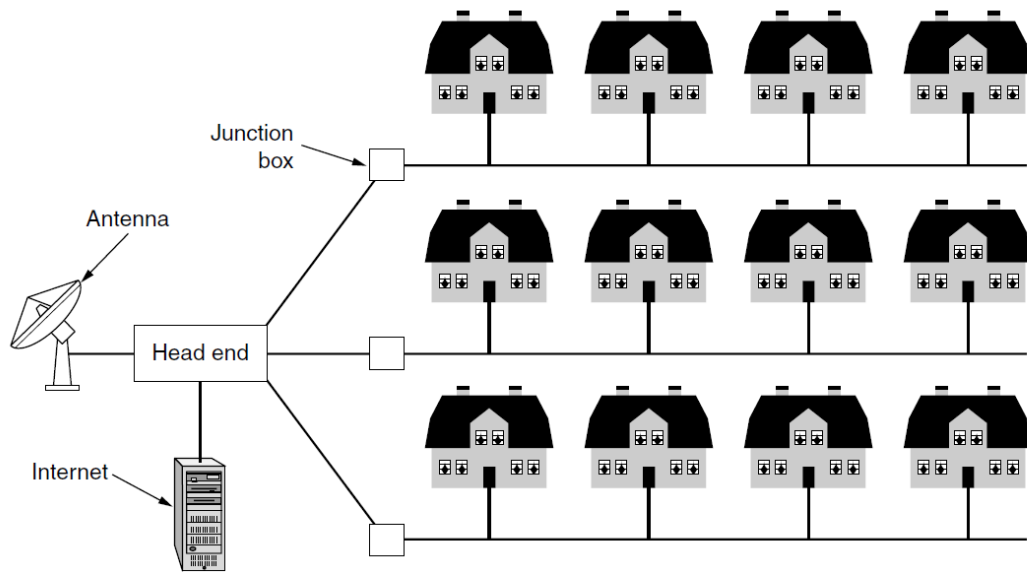

Figure 7. Example of a MAN. Reprinted from Tanenbaum & Wetherall (2010, p. 24)

Goyal (2019) comments that a WAN “extends over a large geographical area, although it might be confined within the bounds of a state or country”. Tanenbaum and Wetherall (2010) give an example of a company with offices in different cities. A communication subnet or a subnet connects hosts – computers. The primary purpose of a subnet is to carry messages from host to host. A subnet consists of two components (Tanenbaum & Wetherall, 2010):

- 1) a transmission line made of copper wire, optical fibre or radio links. Its function is to move bits between computers. You can rent a transmission line from a telecommunication company;
- 2) switching elements or just switches that are switching computers called routers whose function is to connect two transmission lines.

A WAN is also a wireless connection that can work through the Internet. Tanenbaum and Wetherall (2020) give one example of a wireless WAN a telephone network which has already passed through five generations.

The network indicates the distance in which the device works; for the proper functioning of smart devices, they need to be connected. The interconnection of these devices creates a pattern of how the devices are interconnected. This connection can be distinguished by the topologies described in the following chapter.

4 Topologies used in home automation

Singh (2019) states that topology is a geometric representation of how devices are connected. Palmer (2006) states that each network is composed of a different combination of wiring, workstations, software and network equipment. These elements could be combined according to needs and resources. Growth potential is directly affected by the network topology. Palmer (2006) also distinguishes the following main topologies: bus, ring, star and mesh. Besides, he describes so-called hybrid topologies that include a star-bus and star-ring topology.

4.1 Bus topology

Serrenho and Bertoldi (2019) refer to a bus topology as “networks in which the network nodes are directly connected through a wire to a common link, called a bus” (p. 35). They add that these networks are simple, reliable and traditionally appear in households where a wire interconnects all the devices in a LAN. Palmer (2006) compares a bus topology to a chain – it has a starting point and an ending point. As illustrated in Figure 8, each end of the bus topology has a terminator that signals the physical end of the segment. When transmitting a packet, it is detected by all nodes.

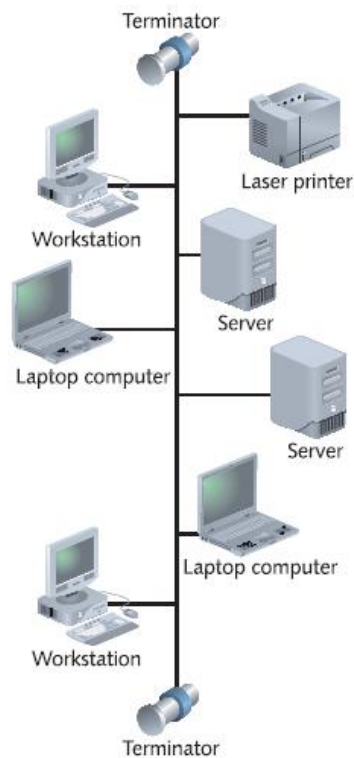

Figure 8. Example of a bus topology. Reprinted from Palmer (2006, p. 20).

Palmer (2006) claims that this topology works best for small networks and is comparatively cheap to implement. The cost of this topology could be minimized because of fewer wirings. Another advantage is that it is easy to add a new device. The two main disadvantages are high costs of the management and that this topology could become overflowed – it needs additional network devices to control the traffic flow (Palmer, 2006). Serrenho and Bertoldi (2019) add that there are also cable losses.

4.2 Ring topology

Palmer (2006) observes that “the ring topology is a continuous path for data with no logical beginning or ending point, and thus no terminators” (p. 21). Figure 9 confirms that this topology has no terminators. When data is transmitted, it goes around, from one device to another getting to its destination. Then it continues until it ends at the source device. Palmer (2006) points out that “new high-speed ring topologies employ two loops for redundant data transmission in opposite directions; thus, if loop in one direction is broken, data can still reach its destination by going in the opposite direction on the other loop” (p. 21). He also highlights more straightforward managing and overall, more reliable communications than in the traditional bus topology.

The main disadvantage is that it can be more expensive to implement because of more wiring and network equipment. Also, this topology is not used as much as the bus topology (Palmer, 2006). As Serrenho and Bertoldi (2019) note, “bandwidth is shared among all nodes of the network, which could cause communication lag among all the nodes” (p. 35). Moreover, this topology is not very reliable, and it can be used only in small networks.

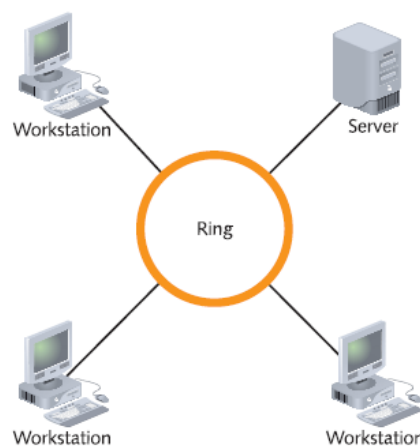

Figure 9. Example of a ring topology. Reprinted from Palmer (2006, p .21).

4.3. Star topology

According to Palmer (2006), a “star topology is the oldest communications design method, with root in telephone switching systems” (p. 22). The layout of this topology consists of multiple nodes that are connected to a central device such as a switch or a router, as shown in Figure 10. As the ring topology, the star topology is easier to manage than the bus topology because faulty devices can be recognized and then isolated quickly from the network while other devices are not affected.

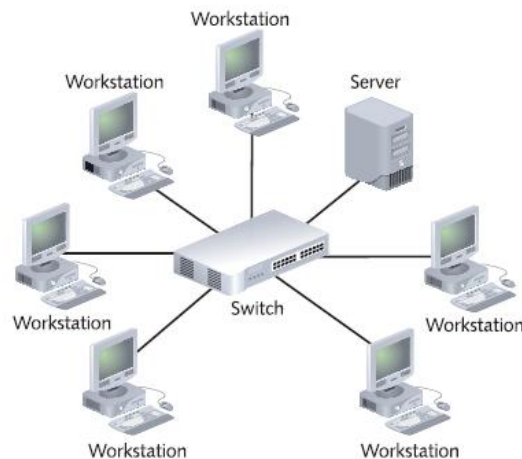

Figure 10. Example of a star topology. Reprinted from Palmer (2006, p. 22).

This topology offers the best options for upgrading into high-speed networking (Palmer, 2006). Serrenho and Bertoldi (2019) point out that the main advantage is that if one or more devices fail, this topology still runs. Palmer (2006) also acknowledges that a ring topology is the most popular one. Serrenho and Bertoldi (2019) also mention that if the central device fails, it leads to the breakdown of the whole network.

4.4. Mesh topology

Serrenho and Bertoldi (2019) explain that a “mesh topology is expected to play an important role in the Internet of Things” (p. 36). We can use wires, but mesh networks are more efficient in a wireless mode with routers that work through radio devices which carry data wirelessly. The device function both as a receiver and a transmitter (Serrenho & Bertoldi, 2019). As we can see in Figure 11, every device connects to every other, so if a link fails, every computer can still communicate with all other devices (Palmer, 2006). According to Palmer (2006), this connection enables fault tolerance, which means “there is build-in protection in case there is an

equipment or communication failure” (p. 24). Palmer (2006) also notes that the more devices in the mesh network, the more alternate ways of communicating. He also mentions the usage of this topology, preferably in MANs or WANs than in LANs because this topology can have a large number of clients who demand reliable communication. Serrenho and Bertoldi (2019) add that this topology is interesting if redundancy is required.

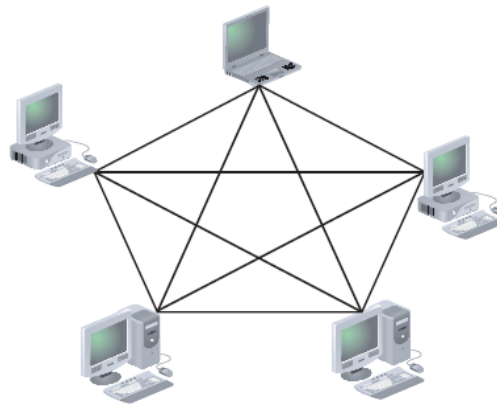

Figure 11. Example of a mesh topology. Reprinted from Palmer (2006, p. 24).

4.5 Hybrid topology

According to Palmer (2006), modern networks “combine the logical communications of a bus with the physical layout of a star, called a star-bus hybrid topology” (p. 24). Each finger sticking from the star is like an isolated logical bus segment. Both ends of the segment are still terminated, but the advantage is that the terminators are not exposed. Another advantage of this design is that as long as you follow standard network specifications for communication cable distances, the number of attached devices, switches and hubs, you can connect several switches or routers and expand the network in many directions. Hubs, routers, and switches have built-in intelligence to help detect problems (Palmer, 2006).

According to Palmer (2006), ring topologies nowadays are designed typically in the physical layout called a star-ring hybrid topology. A hub or success point acts like a linking device which replicates transmission of the signal from a device to a device through the logical communications of a ring. There is no need for built-in terminators as in the star-bus hybrid configuration because communication is facilitated in a ring (Palmer, 2006).

5 Distributed control system

Koziorek, Kocián, Chromčák and Lárýš (2011) discuss that a distributed control system (DCS) consists of several sub-systems that are interconnected by a communication bus and together participate in the control. Elprocus (n.d.) writes that “it is a specially designed control system used to control complex, large, and geographically distributed applications in industrial processes” and controllers are distributed all over the area.

Figure 12 illustrates a DCS that is organized in a two-level hierarchy. Supervision Module (SM) is a high-level module which performs supervision tasks. Control Modules (CM) are low-level modules that over input and output devices interact with the physical world. A communication network interconnects SM and CM (Nunes & Delgado, 1998).

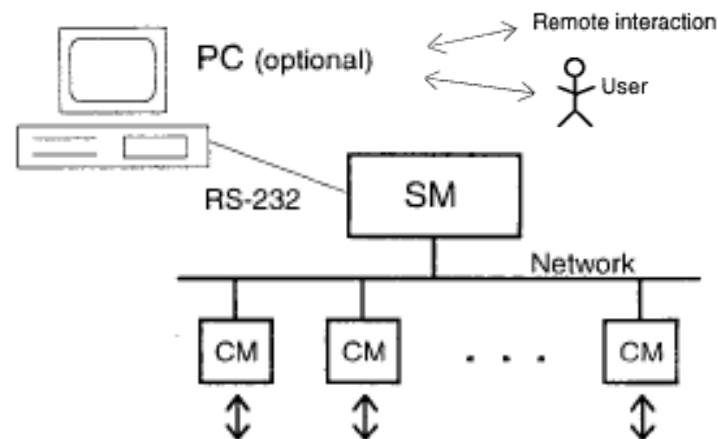

Figure 12. Example of a distributed control system.
Adapted from Nunes and Delgado (1998, p. 260).

Nunes and Delgado (1998) note that the personal computer (PC) is not essential in this system because it does not perform any direct control or supervision actions. However, the crucial roles of the PC are:

- to support a high-level user interface,
- to allow system programming and configuration,
- to allow remote interaction with the system.

Koziorek et al. (2011) list advantages of a DCS as follows:

- higher performance options,
- wiring savings,
- easier debugging of a new application,
- expansion – the control system can be gradually expanded by adding more devices on the communication bus.

The disadvantages, according to EEGGUIDE (n.d.) are:

- it requires a skilled operator,
- a high degree of redundancy and mean time between failures are needed in case of failure of an operator,

A DCS is one of the most effective solutions for a smart home. Will also be used in the practical part of this work. An essential prerequisite for the possibility of implementing a DCS is communication. (Koziorek et al., 2011). Communication can be done in multiple ways with different protocols. The next chapter describes these ways of communication and distinguishes their functions.

6 Communication

Mocrii et al. (2018) explain that if we want to obtain more useful information, we need more sensors and devices that communicate with each other and extend the usefulness of the received information. Communication protocols determine how devices and sensors communicate and also define how the information is transmitted. These protocols are, according to Mocrii et al. (2018), generally classified into three groups by the medium of propagation.

- wired,
- wireless,
- hybrid.

The choice of technology depends on its use; some offer longer ranges, some higher security and other low power consumption. The size of the network is another aspect to consider when choosing a communication protocol (Mocrii et al., 2018, p. 90).

6.1. Wired communication protocols

Mocrii et al. (2018) consider this type of communication to be one of the oldest ways to transmit information, and they add that it is transmitted over wire medium.

Security is one of the advantages because it is almost impossible to hack this protocol from the outside, thanks to a physical connection with the cable. It is easy to connect to a network; the user just plugs the cable in; there is no need to choose the network from the network list or enter a password. Data transmission in wired communication will go further than standard wireless protocols can achieve. This type of communication is more constant and theoretically faster than wireless communication. Moreover, it is not affected by interference or other obstacles (Mocrii et al., 2018, p. 90).

Mocrii et al. (2018) also describe disadvantages like mobility – it is not possible to change the location of the device without rewiring once the cables are set in place. The wired network needs to be built up when the home is built, otherwise “running cables through walls at a later time can become a tedious work, and not look aesthetically pleasing” (Mocrii et al., 2018, p. 91).

There are a lot of wired communication protocols. A selection of the most frequent protocols is listed below, including their benefits and limitations.

Modbus RTU

Real Time Automation (n.d.) describes Modbus RTU as an open serial protocol derived from the original Master/Slave³ architecture. This serial level protocol is widely accepted because of its reliability and ease of use. It is used in Building Management Systems and Industrial Automation Systems. Real Time Automation (n.d.) further states that:

Modbus RTU is an open standard, meaning that manufacturers can build it into their equipment without having to pay royalties. It is the most pervasive communications protocol in industrial automation and is now the most commonly available means of connecting industrial electronic devices.

This protocol has simple messages which ensure reliability. Real Time Automation (n.d.) also points out that it is very easy to integrate equipment compatible with Modbus into an existing or new control and monitoring applications since it is supported by almost every commercial server and data acquisition software program in the marketplace.

LonWorks

According to Real Time Automation (n.d.), LonWorks⁴ is a dominant networking solution for building automation. Ismosys (2020) describes LonWorks as “a networking platform specifically created to address the needs of control applications”. LonWorks enables any device to exchange data with any other LonWorks device on the network. A power line or even Ethernet can be used as a communication channel in LonWorks (Real Time Automation, n.d.).

Ethernet

Orfanos, Kaminaris, Piromalis and Papageorgas (2019) state that this protocol is one of the most popular in networking. Noll (2019) points out that Ethernet allows sending data very

³ The master-slave architecture is a traditional solution, which is commonly used. One master handles data writes and multiple slaves are used to read data. It is used when an end user uses services, which requires data reading from the database and small number does data writing for database updates. The architecture thus supports read scalability as the number of slaves can be scaled out easily in cloud according to needs at a given time. (Shrestha, 2017)

⁴ Lon (in LonWorks) stands for the local operating network.

quickly in large quantities – the data rate is from 1 Mbps to 100 Gbps. The range is up to 100 m, and it is not much affected by electromagnetic interference (Mocrii et al., 2018, p. 91).

Benefits of Ethernet are the communication distance, speed of the data transmission, and security since it is hard to access the cable which is buried in walls. A significant limitation is the installation cost and the fact that you need to open the wall for adding the cable to the existing network; it is rather messy and costly work. All wires return to the central switch that controls the traffic on the network; therefore, Ethernet requires a central data closet. This closet could be just a rack-mounted to the wall, but it is still needed to plan it and set aside some space (Noll, 2019).

X10

X10 is a powerline technology – it uses existing electrical wiring to send and receive commands. Pico Electronic developed this protocol in 1975, and since then, it has remained in use “although the technology has not advanced to keep up with newer systems” (Noll, 2019). Mocrii et al. (2018) state that the operation range is up to 1000 m, and this system is a hybrid technology, that has radio frequency (RF) extension for increasing reliability of the network. X10 is suitable for simple light control (Noll, 2019).

This technology is relatively cheap and easily added to homes without communication wiring. Reliability is better than in wireless technology. Controlling the devices remotely within your home is possible via radio transmitters. Some X10 controllers can connect to the Internet, which gives you control from outside of the house (Noll, 2019).

The data rate of X10 is from 20 to 60 bps, which is low; the next flaw is interferences and data loss because of connecting to AC electrical wiring (Mocrii et al., 2018). Noll (2019) comments that X10 is not as easy to use as newer technologies. SafeWise (2018) claims that “this standard likely won’t work well with smart home devices needing fast connections”.

INSTEON

INSTEON is a hybrid technology that uses the mesh topology, so devices can communicate with each other and repeat the message to extend the coverage area without needing a central hub (Mocrii et al., 2018). Orfanos et al. (2019) report that this system is “designed in order to replace the X10 standard for the integration of power line systems with wireless” and its design

“enables devices (sensors, switches) to collaborate regardless if they are connected with power lines or RF” (p. 6). They also point out that it is one of the few technologies that can communicate both wireless and wired.

Noll (2019) emphasizes that redundancy the system provides is its most significant benefit as well as the fact that “if wireless is down or there is some sort of interference, the system easily changes to powerline communications and vice-versa” (Noll, 2019). Another advantage highlighted by Mocrii et al. (2018) is reliability, ease of use, quick message propagation and combability.

Slow data rates of this system are not suitable for use in a sensor because it generates an enormous amount of data, but it fits for control of the devices (Mocrii et al., 2018). A significant drawback mentioned by Noll (2019) is also the lack of the third-party option, so the users are locked into the INSTEON ecosystem.

6.2. Wireless communication protocols

Mocrii et al. (2018) explain that wireless communication protocols do not use wires to transmit, and they receive information using signals. These protocols are becoming more widespread in smart homes for their user-friendliness and low cost of setting up a network and adding new devices.

As Fette et al. (2008) and Mocrii et al. (2018) point out, mobility is one of the main advantages of wireless protocols because the connection to the network does not require any physical connection. This allows the device to move without losing connection. Mocrii et al. (2018) also add that connecting the device to another network is simple, and it requires adding new devices and scaling up or down as needed with minimal or no costs. Setting up a wireless network is not difficult and can be done without professional help, so the prices are not high. Since the creation of the network involves only the connection of the device to power, it is easy to experiment with the location of the sensor and new appliances.

Mocrii et al. (2018) mention that although it is highly unlikely and current encryption mechanisms are strong, packets in wireless communication are carried by the air and can be intercepted and decrypted. The lack of proper configuration and the networks’ associated vulnerability is why most security problems arise. Theoretical speeds of the wireless networks

are lower than of the wired networks; however, in practice, the data rates are often sufficient for most smart home applications. Another disadvantage is the interference to which the wireless network is susceptible, which can affect and disrupt the quality of the services. A wireless network can cover a larger area than a wired network. However, incorrect device placement or obstacles can reduce the coverage area and result in the loss of commands and messages.

There are many wireless communication protocols. A selection of the most frequent protocols is listed below, including their benefits and limitations.

Wi-Fi (Wireless Fidelity)

This protocol has become one of the most popular wireless technologies in use because it does not require a license (Mocrii et al., 2018, p. 92). Noll (2019) comments that “since Wi-Fi is so common in homes today, it makes sense that home automation accessories take advantage of its availability” and adds that Wi-Fi is not for all accessories that we use in a smart home. Radio waves in the 2.4 GHz or 5 GHz spectrum are used for communication. The range may vary depending on the hardware used, physical barriers, interference, antenna quality, and transmitter power.

Ranging from 10 Mbps to 100 Mbps, transmission speed is one of the advantages which allows streaming high-definition audio and video. A Wi-Fi repeater can exceed the range, and the overall availability of this technology is another advantage. Wi-Fi provides easy and reliable access to the Internet anywhere; it is also cheaper than running Ethernet cables around the house (Noll, 2019).

Noll (2019) also lists a few drawbacks of Wi-Fi. One of them is susceptibility to interference due to the connection of many devices. Another disadvantage is power consumption; however, this does not mean that it affects our bills. The main problem is that you do not want to plug in all smart home devices, especially small ones, so batteries are necessary. The range can be considered both an advantage and a disadvantage. Large homes made of dense materials are a problem. In this case, the installation of another router to create a mesh network is needed. The last limitation is security; we need to ensure that our security protocol is well configured and updated.

Bluetooth

Noll (2019) states that Bluetooth connectivity is used in a smart home for close-range connectivity because at short distances it provides faster wireless data transmission than Z-Wave or ZigBee. Mocrii et al. (2018) point out that this wireless technology is the most popular for PANs, and mobile and wearable devices. Bluetooth uses a 2.4 GHz band, and the system runs as a master/slave setup where one device could be a master up to seven slave devices. There are also multiple versions of Bluetooth marked from 1 to 5. Bluetooth 1.0 has a bandwidth of about 1 Mbps, versions 3.0 and 4.0 provide data transfer rates of around 24 Mbps (Noll, 2019). The latest Bluetooth 5 “introduced several improvements for the BLE⁵ version, with a focus on emerging IoT device support, such as improved range, improved channel selection, and increased data rate” (Mocrii et al., 2018, p. 92).

Noll (2019) claims that the pairing method is the most significant advantage of Bluetooth. It is fast and easy for devices to discover and connect to each other. Bluetooth uses a low amount of power, which means it can be battery operated. Low power consumption is suitable for small appliances and sensors that do not require high bandwidth. This technology is inexpensive to implement; therefore, it is frequently used in electronics today.

According to Noll (2019), the fact that it operates at 2.4 GHz frequency is the biggest disadvantage of Bluetooth. 2.4 GHz frequency is very busy, which makes Bluetooth susceptible to interference from other devices. The next disadvantage is bandwidth which does not allow video transmission and is best used for audio streaming or issuing commands among different accessories.

ZigBee

Jain and Kumar (2018) mention that ZigBee is open-source and free to use by anyone communication protocol based on IEEE 802.15.4⁶ and used for a wireless PAN. The 16-bit short address allows connecting up to 65536 different devices except for some reserved addresses. ZigBee provides equipment for executing secure communication and operates in the 2.4GHz, 900 and 868 MHz bands. Dhillon and Sadawarti (2014) describe ZigBee as a

⁵ BLE (Bluetooth Low Energy) is a subset of Bluetooth which is aimed for low power devices that can run on a cell battery for a long period of time (Mocrii et al., 2018, p. 92).

⁶ IEEE 802.15.4 is a technical standard that explains the operation of low-rates wireless personal area networks (LR-WPANs) (Jain & Kumar, 2018, p. 1).

“communication technology used to connect local networks with wireless sensing nodes which tend to consume low power without sacrificing the reliability and sustainability of the networks” (p. 1). Noll (2019) writes that ZigBee is a mesh network developed for short-distance communications with low-speed and low-bandwidth. The indoor range is about 9 meters and can be significantly increased due to a hop between devices.

ZigBee consists of three logical devices: a ZigBee coordinator, a ZigBee router, and a ZigBee end device. According to Dhillon and Sadawarti (2014), the ZigBee coordinator’s primary function is to initiate the network and select all the network parameters such as topology, packet size, radio frequency channel, and other operational parameters. The coordinator allows us to communicate with the network from the outside world and manages all nodes in the network. The ZigBee router is an intermediate device which means that it routes the data from one device to another. It can talk to the coordinator as well as to the other routers. This device can sense the data from their surrounding environment (Jain & Kumar, 2018; Dhillon & Sadawarti, 2014). End devices are mostly low-powered or battery-powered devices with limited computing capabilities designed for collecting various information from sensors and switches. As Dhillon and Sadawarti (2014) mention, the end device cannot transmit data from other devices than the coordinator or a router. Each device can have up to 24 end nodes and does not have to stay awake the whole time, unlike the coordinator and the router.

Noll (2019) highlight mesh network and low-power requirements of the radio as the most significant advantage. Rana and Pawar (2010) highlight another essential advantage of ZigBee: low-cost, easy to deploy, secure data transfer, reliable data transfer and fact that ZigBee can be implemented with any type of microcontroller.

Noll (2019) sees the biggest drawback of ZigBee in its little popularity and limited production and offer on the market.

Z-Wave

Z-Wave is, according to Mocrii et al. (2018), reliable technology aimed at low-powered devices. Because Z-wave is a patented technology, you need to obtain a license and certification from the Z-Wave Alliance. Garg and Gupta (2020) state that a simple protocol used by a Z-Wave enables faster and easier development. Unlike other technologies such as ZigBee and similar, which have several chip manufacturers, Z-Wave has a single chip manufacturer, Sigma Designs. Noll (2019) identifies two radio bands, 908 and 916 MHz, on which this protocol

operates and mentions that “each device can send and receive commands or pass commands along to other devices”, which creates a mesh network and enhances the range of each device. Data transmission speeds are lower than ZigBee or Wi-Fi (from 40 to 100 Kbps); however, it is not a limitation since Z-Wave is used to send commands and not stream significant amounts of data. The open-air range is about 100 meters and the indoor range around 30 meters. Two hundred thirty-two connected devices are the maximum that can Z-wave handle, which is enough for home automation.

Noll (2019) summarizes that one of the few benefits is a reliable network across long distances provided by the mesh network. Thanks to the 908 and 916 MHz radio band, there is less interference than other options. Another benefit is the small amount of power used by radios, eliminating wired connection, and running devices on batteries.

The only and most significant limitation is slow transmission speed, limiting to only sending commands and control functions. This is confirmed by the fact that no security camera on the market supports Z-Wave.

7 Smart home services

7.1 Home conditions measurement

Lalanda, Bourcier, Bardin and Chollet (2010) state that heating and cooling in a house deserve special attention because it is the major item in the house service bill; therefore, smart sensors inside and outside the house can manage energy consumption efficiently. Domb (2019) claims that “a typical smart home is equipped with a set of sensors for measuring home conditions, such as temperature, humidity, light and proximity” (p. 2) and adds that every sensor captures one or more measurement. Lalanda et al. (2010) mention that the data from sensors that cover inside and outside of the house can be processed to the control units, which then can, for example, stop heating the room when the window is open and then close the window or alarm the user about it. The user can be advised to shut the curtains in the night when the temperature outside is much lower than the temperature inside the house while the heating system is on. Domb (2019) points out that every sensor allows storing and visualizing the data so the user can see it anytime and anywhere thanks to a signal processor, a communication interface, and a host in a cloud infrastructure.

7.2 Smart home security

According to Lalanda et al. (2010), security and safety are essential attributes of human life, and every smart home occupant should incorporate safety issues in his smart home. The market offers various products to deliver different aspects of safety, alarm and security. Mantas, Lymberopoulos and Komninos (2010) mention that the security of a smart home includes several identification mechanisms, such as voice, face and biometric recognition, smart cards that provide control, and RFID tokens. The security system also consists of notification mechanisms such as burglar alarms that allow immediate reaction, surveillance mechanisms such as CCTV for monitoring inside and outside of the house, vibration shock sensors and glass-break sensors to detect an invader to the home. Lalanda et al. (2010) list the following sensors: smoke detectors, water leakage detectors, intruder detectors, or power outage detectors, which are interconnected and monitor specific conditions or situations that are then transmitted to the server and the concerned parties. A user can control some utilities of their home remotely via the Internet or their mobile phone. The security system can also simulate the presence of the occupants inside the house by switching on and off the home lights at a regular time when they are on holiday.

7.3 Home appliances management

Lalanda et al. (2010) point out that smart home appliances can operate in much more intelligent and sophisticated ways by employing sensors and connecting them to the smart home network. Smart appliances could be controlled and monitored remotely by remote control or mobile phone via the Internet. Some machines can behave smartly by reporting problems to the service company or the user. Furthermore, a washing machine can scan the load and adjust the cycle for the fabrics used; after scanning the products, a refrigerator can control their expiry dates and warn the user in advance. One way to notify the user about the problem or status of the appliance is through a message or notification on the controller/mobile phone; another way to do it is through a Digital Personal Assistant or home assistant.

7.3.1 Digital Personal Assistant

Enge (2019) defines the Digital Personal Assistant as a software-based cloud service that is created to help the user complete tasks, such as home control, managing schedules, answering questions, and playing music. Edu, Such and Suarez-Tangil (2020) write that assistants use Internet services and, thanks to the recent advances in Natural Language Processing (NLP), they are allowed to handle a wide range of commands and questions. Using the assistant is even more engaging because it enables a playful interaction. Every personal assistant has a name and gender, which personifies them, and the user interacts with them in a human-like manner. Modern assistants are able to make a phone call, which makes them a communicating device too.

8 Smart home components

Domb (2019) claims that for all activities and data management to work, the system includes five groups of components, as illustrated in Figure 13. The first group are sensors that, as Domb (2019) explains, are connected to the home itself and to the attached-to-home devices. The purpose of the sensors is to measure home conditions and collect internal and external data that are then continually transferred through the local network to the smart server.

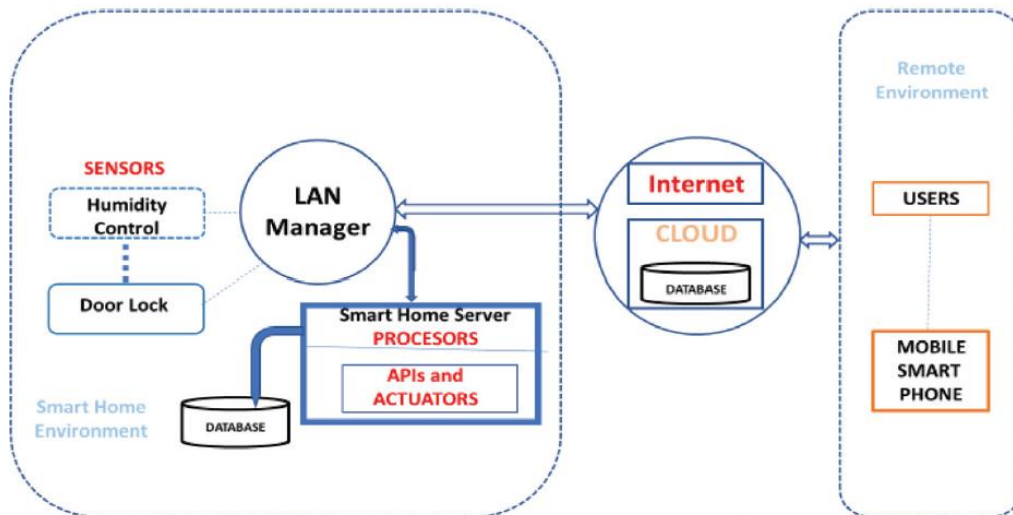

Figure 13. Smart home components. Reprinted from Domb (2019, p. 4).

The second group are processors that perform local and integrated actions. If the applications require extended resources, the processor can be connected to the cloud, and data from the sensors are then processed by the local server processes. Domb (2019) describes the following group of components as “a collection of software components wrapped as APIs, allowing external applications to execute it, given it follows the pre-defined parameters format. Such an API can process sensors data or manage necessary actions” (p. 3). The task of the actuators, the fourth group, is to provide and execute commands in the server or other control devices. The actuator translates activity to the command syntax. While the actuator processes the received data from sensors, the task checks if any rule becomes true and if so, it launches command to the suitable device processor. The last group is the database that stores the processed data collected from the sensors, analyses, presents and visualizes them.

This chapter is the last of the theoretical part. The next chapters will deal with the design of the topology of a distributed control system for home automation using IoT, the determination of action and sensory elements and the selection of appropriate IoT technologies

PRACTICAL PART

9 Design of a smart home

When implementing automation and smart devices in a building, it is first necessary to know the layout of the house or flat, its current state and the specific elements the automation will concern. It is essential to know whether the flat is under construction or whether the equipment will be installed without disrupting anything in the household, for example, you should know how heating works to choose the right elements for a smarter solution. The right choice of automation and smart solutions usually results from carefully selected devices and their compatibility to communicate with each other without any problems.

9.1 Layout and equipment of the household and requirements for a smart solution

Figure 14 shows the layout of the flat in which the smart home equipment will be implemented, and Table 1 provides the names of the individual rooms numbered in the plan. The flat with a bedroom, bathroom, hallway, toilet, utility room and a kitchen connected to a living room is equipped with four windows with manually retractable blinds. There is a radiator under each window; only the bathroom has a bathroom ladder used for heating. The bedroom, bathroom and kitchen with the living room are equipped with an old thermostat to control the temperature of the radiators in the room. The toilet and the bathroom are equipped with a fan for ventilation and air extraction. In both rooms, the ventilation system is turned on by a special switch on the wall for a set amount of time.



Figure 14. Layout of the flat.

Table 1. *Layout legend*

Room number	Room name
1.01	The hallway
1.02	The living room and kitchen
1.03	The utility room
1.04	The toilet
1.05	The bathroom
1.06	The bedroom

The next step is to define the functions each room is required to perform. The living room with the kitchen, hallway, bathroom and bedroom will be equipped with a central control device that will communicate with all the devices in the room and the central devices in other rooms. It will also replace the thermostat function in the rooms. The following paragraphs describe each room and discuss the required functions.

The hallway

The hallway will be equipped with two motion sensors that will work after dark. The smart bulbs will be connected to a motion sensor and central control device that will be placed on the wall that separates the hallway from the living room and kitchen. The manual on/off switches will remain as they are and will work as well. At night, the lights will be dimmed when motion is detected. The main door will be equipped with an open/close sensor that will report an unauthorized intrusion

The living room and kitchen

Instead of the old thermostat, the central control device will be installed. Another device will be a motor for controlling the blinds on the windows. This motor will have to be set to open and close at a predetermined time and it will also be able to be operated manually on the device. The lighting using the bulbs will be replaced by the bulbs that support the dimming mode and, at the same time, can be connected to the central control device and controlled directly with a switch on the wall or a switch at the lamp. For a lamp connected directly to the power supply, it is possible to use a smart socket. The kitchen will be equipped with a ceiling smoke detector and a smart dishwasher that can perform the delayed start and send notifications about the end of the cycle.

The utility room

The light is controlled by a switch on the wall. There is no need to implement anything.

The toilet

The toilet ventilation will be replaced with a motion detection model, so each time someone enters, the ventilation will turn on for a particular time. The light will have its original switch on the wall.

The bathroom

The bathroom thermostat will be replaced with the central control device as in the living room and kitchen, with the difference that the heating is provided by a ladder towel radiator located on the wall. Ventilation will be replaced by a model that can switch on if the humidity in the room exceeds a specific limit and is switched on for a set amount of time. A switch on the wall controls the light that will contain a smart bulb controlled via the central control device. Like a dishwasher, a washer and a dryer can alert the user to a completed cycle with a notification and use the delayed start function.

The bedroom

The thermostat here will be replaced with the central control device which will be the same as in the bathroom, living room and kitchen. The control of the blinds for the window will use the same principle and motor as in the living room and kitchen. The main ceiling light will be equipped with a dimmable smart light bulb. Switching will be possible with a switch on the wall and also via the central control device. Each side of the bed will have its lamp-controlled by a switch. Two LED strips on the sides of the bed with a motion sensor will be connected to the intelligent socket by the bed which will provide lighting at night when the users get out of bed.

Figure 15 shows the placement of smart gadgets in the household. Table 2 provides an explanation of the symbols used in Figure 15.



Figure 15. Layout of the flat with the location of smart gadgets.

Table 2. Explanation of the symbols used in the layout

Symbol	Meaning of the symbol	Symbol	Meaning of the symbol
	Lightning		Central control device
	Motor for blinds control		Motion sensor
	Door security sensor		Smart plug - socket
	Smart appliance		Smoke detector
	Toilet ventilation		Bathroom ventilation

9.2 Topology design

For the layout and requirements for individual rooms, I designed the topology illustrated in Figure 16. It is a hybrid topology that uses the mesh and star topology together. This topology contains a central control device situated in four rooms. Central devices can freely communicate with each other if one central device in the other room stops working. Therefore, if one central device fails, the user can control the room from another central device in another room. This function is a great advantage over a centralized system, which uses one central device for communication through which all communication passes. For example, a topology from Google uses one central device to communicate with all devices. If the central device fails in this topology, the other devices are unable to function.

Less reliable elements can be used for the topology I designed, which means that they are cheaper because the failure of one element does not disrupt the function of the entire flat.

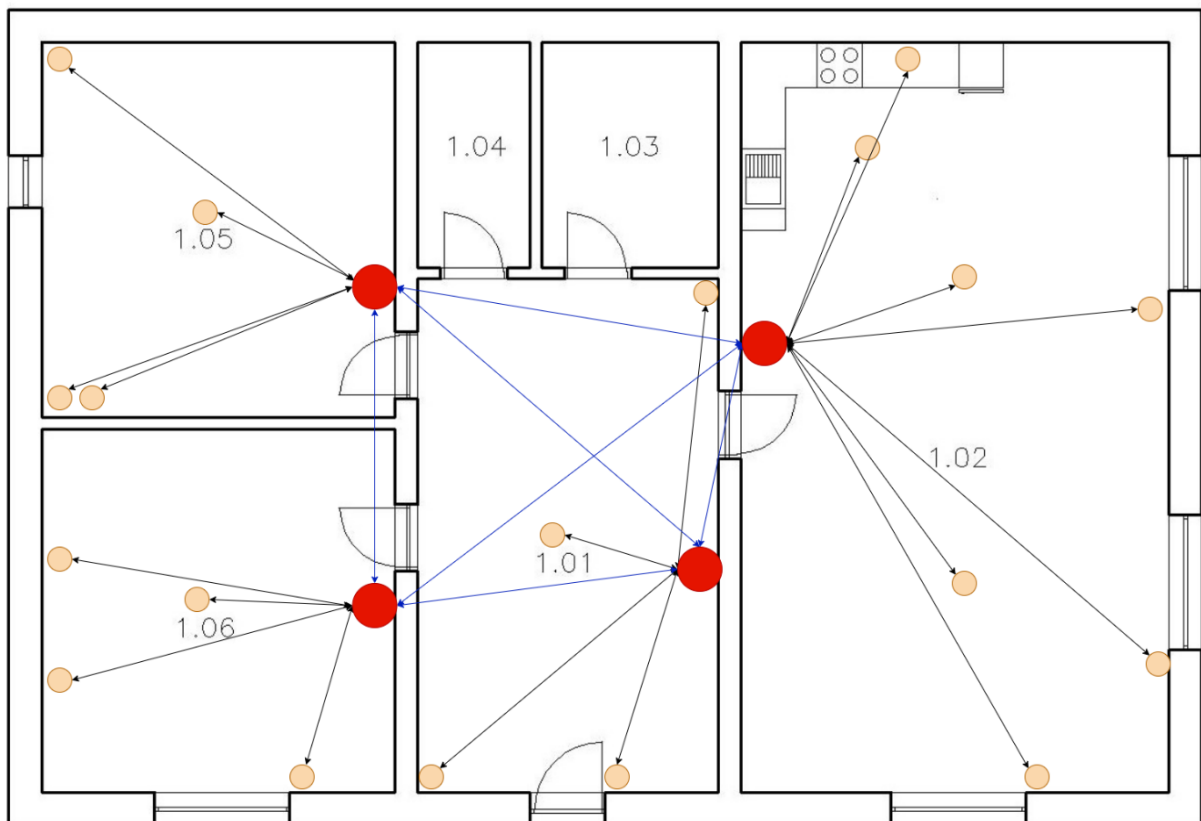

Figure 16. Designed topology.

9.3 Device requirements

This chapter describes the requirements for individual devices that could be used in the designed topology. In addition to the features and functions, I will also list the specific equipment that meets these requirements

9.3.1 Motor for retracting blinds

The motor should be powered either by batteries or by a solar panel installed on the window. Another feature should be the ability to set automatic pull-down and pull-up and stop at a specified position. The device should be controlled by both the central control device and the buttons directly on the device. I present the Benexmart Tuya Wi-Fi motor (see Figure 17) as an example of a device that could be used and at the same time meets all requirements.

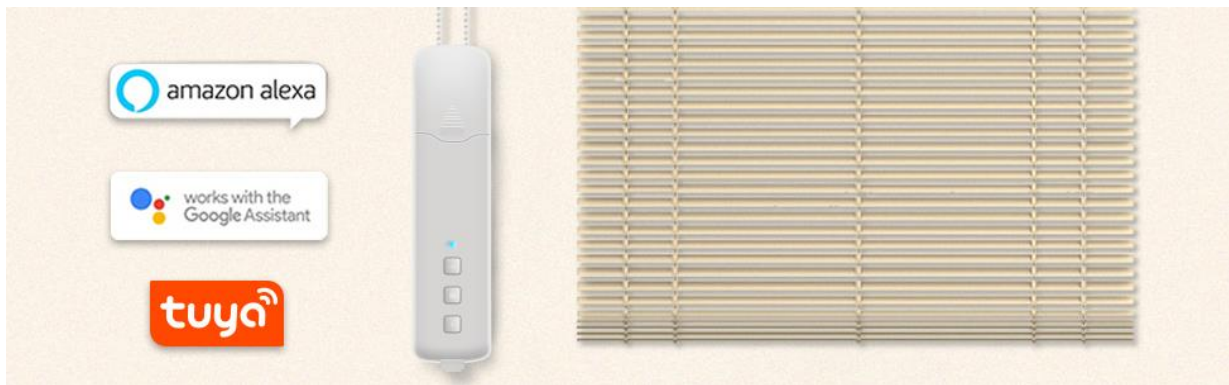

Figure 17. Benexmart Tuya Wi-Fi motor. Reprinted from www.amazon.com.

9.3.2 Smart bulbs

The main requirement for the smart bulbs is the possibility of control using a central device and switches on the wall. Another feature that the lights bulbs should meet is setting them to light dimly at certain times. A feature that is not required, but included in certain types of smart bulbs, is the ability to change the colour of the bulb. Philips Hue and their products meet all requirements, so I would like to mention them here as an example.

9.3.2.1 Smart plug

The smart plug in the designed topology requires setting the times only when it should and should not work. For this function, the user can use the Philips Hue brand and their smart plug again.

9.3.3 Motion sensor

The motion sensor should be inconspicuous but still fully functional, with the ability to cover the area the user needs. AQARA Motion Sensor is a sensor that could be used in my topology.

9.3.4 Smoke detector and air quality measurement

The smoke detector should report the presence of smoke with an audio signal. If the household is equipped with a gas stove, the detector should also detect a gas leak. The iQtech SmartLife CS01W Combo CO performs both functions and would therefore be suitable to use. Another device that can be used not only for smoke and gas detection but also for the overall air quality measurement is Reair. This device designed at the Faculty of Electrical Engineering and Communication Technologies in Brno by Jiří Janoušek and Dominik Klement can measure air quality and factors affecting health and human productivity. Reair can measure the level of carbon dioxide, the presence of volatile organic compounds and dust particles, and last but not least, temperature and humidity.

9.3.5 Ventilation

The topology uses two fans, one in the bathroom and the other in the toilet. However, each of them should meet different requirements. The ventilation in the bathroom should switch on for a set time after detecting a certain level of humidity. These requirements are met by the Broan AER110S fan which is equipped with a humidity sensor. Toilet ventilation should turn on when motion is detected for a predetermined time. Broan ZB80M is equipped with a motion sensor and is therefore suitable for this case.

9.3.6 Door sensor

The sensor for detecting the opening and closing of the door should report unauthorized intrusion with the help of a notification to the mobile phone or other devices on which it is set. Monoprice meets these requirements.

9.3.7 Central control device

A central control device will replace the function of the thermostat and at the same time serve as a control element. The device should be able to reconnect wires from the old thermostat and communicate with each device in the room and at the same time with other central devices in different rooms. If this device uses wireless communication, it would be appropriate to use Bluetooth 5.0 because this technology supports the mesh topology. At the same time, the range,

transmission speed and security of this protocol are suitable for use in a smart home. Ethernet would be ideal for using the wired protocol that will not break the device if Ethernet stops working. There is currently no device that could meet the requirements of my proposed concept. The solution could be to use the Raspberry Pi with a touch screen and a pre-loaded operating system that can communicate with all devices. Such a device would facilitate the creation of smart homes and at the same time, using the topology I designed, the operation of a smart home would be more straightforward and more reliable.

10 Comparison with other topologies

The topology I designed contains four areas that operate centrally, which means that each device communicates with a central element in its area. In contrast to traditional centralized topologies, all central elements can communicate with each other. This feature is important because if one of the central elements fails, the whole topology can continue to work. However, using one central element through which all communication would be transmitted, the topology would not function in case of failure of the main central element.

One of the topologies that uses a central element to communicate with all devices is, for example, the topology from Google. This topology uses the Google Nest Hub for controlling all devices. Therefore, if this device fails, the entire topology fails.

One of the main advantages of my proposed hybrid topology, which uses the mesh and star topology, is reliability. Another advantage is that we can use devices that are not as expensive and reliable because the failure of one element will not cause the collapse of the entire topology. Compared to other topologies, I consider my topology to be more reliable. The only disadvantage is the temporary absence of a central element that could perform all the required functions. However, I believe that this problem and the gap in the market will soon be filled with devices that can perform such functions.

Conclusion

The aim of this thesis was to design a topology of a distributed control system for home automation using IoT technologies, define its components and choose suitable IoT technologies for each of them. The methodology used in the thesis was a literature review of relevant books, articles, research papers, manuals, videos and blogs concerning the Internet of Things and smart homes.

The thesis initially introduced the Internet of Things, including its history and the state of the art. The next chapters dealt with the smart home and the aspects needed to understand its function. The chapters included a description of a smart home itself, classification and description of the topology and networks used in it. An important task was to understand the function of the distributed control system, which was essential for the design of the topology, as well as to understand the advantages and disadvantages of wired and wireless communication protocols. The following two chapters described the functions of a smart home and described the components that a smart home uses for trouble-free operation.

The practical part of the bachelor's thesis contained the ninth and tenth chapter. First the layout of the flat was planned, including the equipment of the household in which the smart devices should be implemented. Following the selection of the functions the user might want the smart home to perform, each room was described with respect to the required functions. The next chapter introduced the designed topology for a smart home, described it, and compared it with another topology. The third subchapter described the required product functions and gave an example of those that met the requirements and can be used. At the end of this chapter, I found a gap in the market in the form of a central smart home device that would meet the requirements of the proposed topology. Therefore, I suggested that the design of this device could be an interesting challenge for the future. The last chapter compared the designed topology with other topologies and discussed their advantages and disadvantages.

This thesis served as an overview of currently used topologies, communication protocols, services and the components that are used in smart homes. The industry is constantly expanding, and it is, therefore, easier for users to come across this technology. Smart homes technology is now available to everyone, but some people are afraid to use it due to its technical complexity. This thesis aimed to provide potential users with the necessary knowledge and help them understand the technology behind every smart home.

List of references

- Chen, J. (2020). Smart home. Retrieved from <https://www.investopedia.com/terms/s/smart-home.asp>
- Cisco. (n.d.). What is a LAN. Retrieved from <https://www.cisco.com/c/en/us/products/switches/what-is-a-lan-local-area-network.html>
- Dhillon, P., & Sadawarti, H. (2014). A review paper on Zigbee (IEEE 802.15.4) standard. *International Journal of Engineering Research and Technology* 3, 141–145.
- Domb, M. (2019). Smart home systems based on Internet of Things. In Y. Ismail (Ed.), *Internet of Things (IoT) for automated and smart applications* (pp. 21–33). London: IntechOpen.
- Edu, J. S., Such, J. M., & Suarez-Tangil, G. (2020). Smart home personal assistants: a security and privacy review. *ACM Computing Surveys*, 53(6), 1–35.
- EEEGUIDE. (n.d.). Distributed Control System. Retrieved from <https://www.eeeguide.com/distributed-control-system/>
- Elprocus. (n.d.), Everything You Need to Know About Distributed Control System, Retrieved from <https://www.elprocus.com/distributed-control-system-features-and-elements/>
- Enge, E. (2019). Rating the smarts of the digital personal assistants in 2019. Retrieved from <https://www.perficient.com/insights/research-hub/digital-personal-assistants-study>
- Etsi. (2020). Smart body area networks. Retrieved from <https://www.etsi.org/technologies/smart-body-area-networks?jjj=1602182441611>
- Fette, B. et al (2008). *RF & wireless technologies*. Amsterdam: Elsevier.
- Goyal, A. (2019). Types of area networks – LAN, MAN and WAN. Retrieved from <https://www.geeksforgeeks.org/types-of-area-networks-lan-man-and-wan/?ref=rp>
- GreatCall. (2020). What is fall detection. Retrieved from <https://www.greatcall.com/resources/falls/what-is-fall-detection>
- Gupta, S., Mukherjee, T., Venkatasubramanian, K. (2013). *Body Area Networks: Safety, security, and sustainability*. New York: Cambridge University Press.
- Hendricks, D., (2014). The history of smart homes. Retrieved from <https://www.iotevolutionworld.com/m2m/articles/376816-history-smart-homes.htm>
- IEEE. (2016). IEEE Standard for information technology. Telecommunications and information exchange between systems. Local and metropolitan area network – specific requirements – Part 11: Wireless LAN medium access control (MAC) and physical layer (PHY) specifications. *IEEE Std 802.11-2016 (Revision of IEEE Std 802.11-2012)*, 1–3534.

- IGI-global. (n.d.). What is body area network (BAN)? Retrieved from <https://www.igi-global.com/dictionary/body-area-network-ban/2707>
- i-SCOOP. (n.d.). Smart homes: home automation and the smart home in the age of IoT. Retrieved from: <https://www.i-scoop.eu/internet-of-things-guide/smart-home-home-automation/>
- Ismail, Y. (2019). *Internet of Things (IoT) for automated and smart applications*. London: IntechOpen.
- Ismosys. (2020). LonWorks products. Retrieved from <https://ismosys.com/lonworks/>
- Jena, S. (2020a). Overview of personal area network (PAN) Retrieved from <https://www.geeksforgeeks.org/overview-of-personal-area-network-pan/>
- Jena, S. (2020b). Introduction of home area network (HAN). Retrieved from <https://www.geeksforgeeks.org/introduction-of-home-area-network-han/?ref=rp>
- Kim, J. (2016). HEMS (Home Energy Management System). Base on the IoT smart home. *Contemporary Engineering Sciences*, 9(1), 21–28.
- Koziorek, J., Kocián, J., Chromčák, L., & Láryš, T. (2011). *Distribúované systémy řízení: učební text*. Ostrava: Vysoká škola báňská - Technická univerzita
- Kyas, O. (2017). *How to smart home*. Wyk auf Föhr: Key Concept Press.
- Lalanda, P., Bourcier, J., Bardin, J., & Chollet, S. (2010). Smart home systems, Smart Home Systems. Retrieved from <https://www.intechopen.com/books/smart-home-systems/smart-home-systems>
- Mantas, G., Lymberopoulos, D., & Komninos, N. (2010). Security in smart home environment. In A. Lazakidou, K. Siassiakos, & K. Ioannou (Eds.), *Wireless technologies for ambient assisted living and healthcare: Systems and applications* (pp. 170–191). New York: Medical Information Science Reference.
- Mocrii, D., Chen, Y., Musilek, P. (2018). IoT-based smart homes: A review of system architecture, software, communications, privacy and security. *Internet of Things*, 1–2, 81–89.
- Noll, M. (2019). Comparison of home automation protocols. Retrieved from <https://theiotpad.com/tips/home-automation-protocols>
- Nunes, R., & Delgado, J. (1998). An architecture for a home automation system. *IEEE International Conference on Electronics, Circuits and Systems. Surfing the Waves of Science and Technology*, 1, 259–262.
- Orfanos, V., Kaminaris, S. D., Piromalis, D., & Papageorgas, O. (2019). Trends in home automation systems and protocols. *AIP Conference Proceedings*, 2190(1), 1–19.

- Palmer, M. (2006). *Hands-on networking fundamentals*. Boston: Cengage Learning.
- Raj, P., & Raman, A. C. (2017). *The Internet of Things: Enabling technologies, platforms, and use cases*. New York: CRC Press.
- Garg, R., & Gupta, S. (2020). A review on Internet of Things for home automation. *International Journal of Engineering Research & Technology*, 8(10), 80–83.
- Rana, J. & Pawar, S. (2010). Zigbee based home automation. *SSRN Electronic Journal*, 1, 1–4.
- Real Time Automation. (n.d.) Modbus RTU, Retrieved from <https://www.rtautomation.com/technologies/modbus-rtu/>
- Real Time Automation. (n.d.) LONWORKS. Retrieved from <https://www.rtautomation.com/technologies/lonworks/>
- Reddy, M. T., & Krishnamohan, R. (2018). Applications of IoT: A study. *International Journal of Trend in Research and Development*, 4, 86–87.
- Ricquebourgh, V., et al. (2006). The smart home concept: our immediate future. *1st IEEE International Conference on E-Learning in Industrial Electronics, ICELIE*, 23–28.
- Sadiku, M., Tembely, M., & Musa, S. (2017a). Understanding Personal Area Networks. *International Journal of Advanced Research in Computer Science and Electronics Engineering*, 7, 628–629.
- Sadiku, M., Tembely, M., & Musa, S. (2017b). Home Area Networks: A primer. *International Journal of Advanced Research in Computer Science and Software Engineering*, 7(5), 634–635.
- SafeWise. (2018). What are different operating standards for home automation tech. Retrieved from <https://www.safewise.com/faq/home-automation/home-automation-operating-standards/>
- Serrenho, T., & Bertoldi, P. (2019). *Smart home and appliances: State of the art*. Luxembourg: Publications Office of the European Union.
- Shrestha, R. (2017). High availability and performance of database in the cloud – traditional master-slave replication versus modern cluster-based solutions. *Proceedings of the 7th International Conference on Cloud Computing and Services Science*, 413–420.
- Jain, S., & Kumar, S. (2018) Zigbee technology. *International Journal of Engineering Research & Technology*, 6(17), 1–3.
- Singh, C. (2019). Computer network topology – mesh, star, bus, ring and hybrid. Retrieved from <https://beginnersbook.com/2019/03/computer-network-topology-mesh-star-bus-ring-and-hybrid>

- Sinha, D. G., (2018). The evolution of smart home technology. Retrieved from <https://blog.bccresearch.com/the-evolution-of-smart-home-technology>
- Tanenbaum, A., & Wetherall. D. (2010). *Computer networks*. Pearson: United Kingdom.
- Vermesan, O., et al., (2013). Internet of Things strategic research and innovation agenda. In O. Vermesan & P. Friess (Eds.), *Internet of Things – converging technologies for smart environments and integrated ecosystems* (pp. 7–151). Aalborg: River Publishers.

List of figures

<i>Figure 1.</i> Internet of Things in the context of smart environments and applications. Reprinted from Vermesan (2013, p. 24)	p. 13
<i>Figure 2.</i> Application of the IoT in transportation. Reprinted from Krishna Mohan and Reddy (2018, p. 2)	p. 14
<i>Figure 3.</i> Smart healthcare. Reprinted from https://yourstory.com/2018/07/digital-healthcare-palm-hand-smart-idea	p. 15
<i>Figure 4.</i> A body area network. Reprinted from Gupta et al. (2013, p. 12)	p. 19
<i>Figure 5.</i> Example of home area network. Reprinted from www.askotech.com	p. 21
<i>Figure 6.</i> a) Example of a wireless LAN, b) Example of a wired LAN. Reprinted from Tanenbaum & Wetherall (2010, p. 20)	p. 22
<i>Figure 7.</i> Example of a MAN. Reprinted from Tanenbaum & Wetherall (2010, p. 24) .	p. 23
<i>Figure 8.</i> Example of a bus topology. Reprinted from Palmer (2010, p. 20)	p. 24
<i>Figure 9.</i> Example of a ring topology. Reprinted from Palmer (2010, p. 21)	p. 25
<i>Figure 10.</i> Example of a star topology. Reprinted from Palmer (2010, p. 22)	p. 26
<i>Figure 11.</i> Example of a mesh topology. Reprinted from Palmer (2010, p. 24)	p. 27
<i>Figure 12.</i> Example of a distributed control system. Adapted from Nunes and Delgado (1998 p. 260).	p. 28
<i>Figure 13.</i> Smart home components. Reprinted from Domb (2019, p. 4)	p. 40
<i>Figure 14.</i> Layout of the flat	p. 41
<i>Figure 15.</i> Layout of the flat with the location of smart gadgets	p. 44
<i>Figure 16.</i> Designed topology	p. 45
<i>Figure 17.</i> Benexmart Tuya Wi-Fi motor. Reprinted from www.amazon.com	p. 46

List of tables

Table 1. <i>Layout legend</i>	p. 42
Table 2. <i>Explanation of the symbols used in the layout</i>	p. 44