

**BRNO UNIVERSITY OF TECHNOLOGY**  
VYSOKÉ UČENÍ TECHNICKÉ V BRNĚ

**FACULTY OF INFORMATION TECHNOLOGY**  
FAKULTA INFORMAČNÝCH TECHNOLOGIÍ

# **Additional Motor for Electric Scooter**

Doplnění elektrické koloběžky o další motor

**BACHELOR'S THESIS**

**AUTHOR**  
Patrik Staroň

**SUPERVISOR**  
Prof. Dr. Ing. Pavel Zemčík

May 11, 2022  
BRNO

## Zadání bakalářské práce



25212

Student: **Staroň Patrik**  
Program: Informační technologie  
Název: **Doplnění elektrické koloběžky o další motor**  
**Additional Motor for Electric Scooter**

Kategorie: Vestavěné systémy

Zadání:

1. Prostudujte dostupnou dokumentaci a technické řešení elektrické koloběžky M365 a prostudujte též literaturu na téma elektrické pohony,
2. Navrhněte koncepci rozšíření koloběžky M365 o doplňkový zadní motor, navrhněte i koncepci ovládání a elektroniky řešení.
3. Popište dosažitelné vlastnosti navrženého řešení a jeho možnosti, výhody a nevýhody.
4. Doplňte zadní motor do koloběžky M365 a demonstруйте funkčnost řešení.
5. Diskutujte dosažené výsledky, vyhodnořte zkušenosti a navrhněte možnosti dalšího zlepšení řešení.

Literatura:

- Dle pokynů vedoucího

Pro udělení zápočtu za první semestr je požadováno:

- Body 1 až 3 zadání.

Podrobné závazné pokyny pro vypracování práce viz <https://www.fit.vut.cz/study/theses/>

Vedoucí práce: **Zemčík Pavel, prof. Dr. Ing.**

Vedoucí ústavu: Černocký Jan, doc. Dr. Ing.

Datum zadání: 1. listopadu 2021

Datum odevzdání: 11. května 2022

Datum schválení: 3. listopadu 2021

## Abstrakt

Elektrické kolobežky sú veľmi dobré pre každodennú osobnú prepravu. Cieľ tejto práce je pridať sekundárny motor do tela kolobežky a demonštrácia spôsobu jeho ovládania. Elektrická kolobežka Xiaomi M365 Pro 2 bola použitá, pretože je veľmi populárna. Navrhnuté sú dve možnosti ovládania motora. Možnosť s množstvom funkcií a možnosť, ktorá využíva existujúcu elektroniku v kolobežke. Analýza kolobežky a reverzné inžinierstvo bolo prevedené nad riadiacim softvérom a druhá možnosť bola implementovaná a otestovaná. Práca je zameraná na všeobecnú analýzu efektivity kolobežky a sú prezentované parametre pre jej optimalizáciu efektivity.

## Abstract

Electric scooters are very good for everyday personal transportation. The goal of this thesis is to add a secondary motor to the scooter's body and demonstrate how it can be controlled. Electric scooter Xiaomi M365 Pro 2 was used, because it is very popular. Two options for the motor control are proposed. A rich-feature option and an option that uses electronics already present in the scooter. Scooter analysis and reverse-engineering was performed on the control software, and second option was implemented and tested. Thesis is focused on general efficiency analysis of the scooter and parameters for its efficiency optimization are presented.

## Klíčová slova

Elektrická kolobežka, motor, riadiaca jednotka

## Keywords

Electric scooter, motor, controller

## Citace

STARONĚ, Patrik. *Doplnění elektrické kolobežky o další motor*. Brno, 2021. Bakalářská práce. Vysoké učení technické v Brně, Fakulta informačních technologií. Vedoucí práce Prof. Dr. Ing. Pavel Zemčík Pavel Zemčík,

# Doplnění elektrické koloběžky o další motor

## Prohlášení

Prohlašuji, že jsem tuto bakalářskou práci vypracoval samostatně pod vedením pana Prof. Dr. Ing. Pavla Zemčíka Další informace mi poskytl... Uvedl jsem všechny literární prameny, publikace a další zdroje, ze kterých jsem čerpal.

.....  
Patrik Staroň  
11. května 2022

## Poděkování

Ďakujem môjmi konzultantovi Prof. Dr. Ing. Pavlovi Zemčíkovi za nadštandardnú pomoc pri konzultácií práce a prof. Ing. Pavlovi Václavkovi, Ph.D, za odbornú pomoc pri riešení problematiky v tejto práci.

## Table of contents

<b>1</b>	<b>Introduction</b>	<b>2</b>
<b>2</b>	<b>Electric motors - modeling and control</b>	<b>3</b>
2.1	Taxonomy of electric motors	3
2.2	Working principle and modeling of electric motor	12
2.3	Electric motor control	23
<b>3</b>	<b>Electric motor controllers</b>	<b>34</b>
3.1	Safety	34
3.2	Electronics	35
3.3	Commercial controllers	43
<b>4</b>	<b>Current state of M365 scooter</b>	<b>48</b>
4.1	Electric scooters with two motors	48
4.2	M365 Pro 2	50
4.3	Problems with the M365 pro 2 scooter	51
<b>5</b>	<b>Options for scooter upgrades</b>	<b>52</b>
5.1	Ideal option	52
5.2	Low-cost option	53
5.3	Perfectionistic option	54
<b>6</b>	<b>Implementation of the scooter upgrades</b>	<b>55</b>
<b>7</b>	<b>Conclusion</b>	<b>67</b>

## Appendices

<b>Appendix A:</b>	<b>Basics of electricity and magnetism</b>	<b>68</b>
<b>Appendix B:</b>	<b>Clarke transform</b>	<b>84</b>
<b>Appendix C:</b>	<b>Park transform</b>	<b>86</b>

# 1 Introduction

Electric scooters are a good option for regular daily transportation. Electric scooters M365 from Xiaomi are best-selling in their class. However, these scooters have not reached their full potential. They use only one electric motor and that's the reason why it is difficult for them to ride on roads with higher elevation. Another problem is that the information about driving that are shown on the front display are rather minimalistic. The last problem is efficiency. Manufacturer's documentation does not state any useful information through which scooter's efficiency could be estimated. M365 Pro 2 for European market has been chosen for analysis, but the principles of presented solutions are either fully compatible with older models, or they can be slightly modified.

The goal of the work presented in this thesis is to add a secondary motor into the scooter and successfully control its speed. A dual-motor M365 Pro 2 scooter was thus built and tested and the process and summary is available here. Summaries of all relevant information that concern scooter efficiency are also described.

As the price of combustible gasoline rises and technology of electric propulsion advances, we as a society can expect that electrically based propulsion will be used more and more. This thesis can be of help to an individual who wants to understand how electric scooter is controlled, or to a person who wants to upgrade their own M365 scooter.

This thesis contains information explaining how motors works, how to drive them (chapter 2), what is a motor controller and how losses are generated there (chapter 3). Also safety aspect of electric vehicles was studied and a brief report is provided here. Lastly, analysis and solutions for a good quality driving experience, as well as low-cost variant is shown and the low cost variant is implemented (chapter 4, 5, 6).

## 2 Electric motors - modeling and control

Electric motors are divided into many categories and the scope of control for each of them is rather complicated. This chapter describes various classifications of electric motors with later focus on the one used in electric scooters. This chapter contains only information relevant for the thesis and it does not have an encyclopedic character, due to its limited size. Content of this chapter provides a basic orientation in the field of electric motors. Understanding different kinds of motors and their principles helps the reader in making decisions when buying an electric motor, or helps them understand the bottlenecks of electric motors, specifically those used in electric scooters. This section is bulky because multiple clarifications need to be done in order to avoid later confusion. This chapter also introduces the concept of control loops. This is useful if the reader decides to make their own control system, or if they want to understand some parameters in their configuration environment. Concepts here are applicable not only to electric scooters, but to personal electric vehicles in general.

Motor is a device, that converts energy from electrical form to motion. It is composed of two main parts - rotor and stator. Rotor is a part of the motor that turns in relation to stator which is modeled as a stationary part.

### 2.1 Taxonomy of electric motors

Firstly, motors will be classified by their visual and construction parameters.

#### **Rotor placement**

Standard motor is composed of two construction parts - body of the motor and an armature with shaft. There are also motors with two rotors, but they are out of scope of this report. Body of the motor can be rotor or stator. The same applies for armature with shaft. If the body is a rotor, that rotor is classified as outer, because it is located on the outside of the motor. Hub motors in electric scooters have an outer rotor. More concretely, these motors are named in-wheel motors, because they are embedded in a wheel. This rotor faces ground through a tire. Armature is the stator and through the shaft it is mounted onto the frame of the scooter (Figure 2).

The opposite of outer rotor is an inner rotor. These are present inside the motor body as the armature and torque is available through the shaft (Figure 1). This configuration is mainly used in the industry. Stator is mounted onto the machine. In the figures, rotor is marked in green.

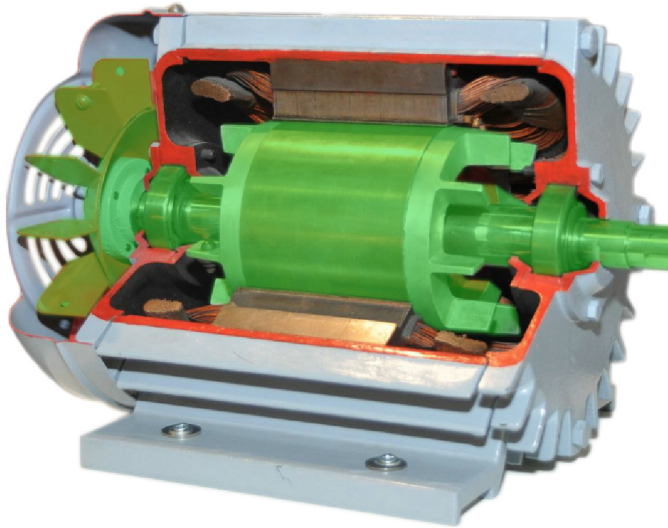

Figure 1: Industrial motor

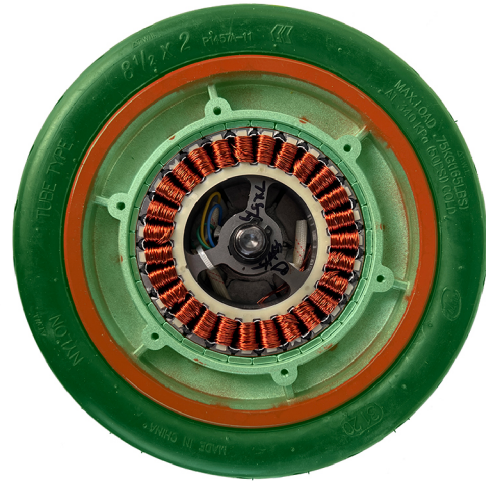

Figure 2: Hub motor

### Types of motors

Both rotor and stator have elements that can produce a magnetic field. Torque is created through forces that are the result of attraction and repulsion of rotor and stator. Rotor and stator must interact through the magnetic field in time, to achieve forces. Torque in relation with load on the motor results in acceleration and that results in speed. Direction of the motor is commanded by the signal phase angle for individual coils during coils excitation, which is a process where coils create a magnetic field. This excitation is electronically controlled.

Both rotor and stator need means to generate a magnetic field. This can be either a source of permanent field, which are permanent magnets, coils, or a core, that can be magnetized via induction. Possible combinations of these configurations are:

- Magnets in rotor and coils in stator (permanent magnet motors)
- Coils in rotor and coils in stator (wound, induction, separately excited motors)
- Inductive core in the armature and coils in the body (induction motors)

Permanent magnet create magnetic field thanks to their polarization. One disadvantage is that the strength of this field is determined during production and magnets can weaken by overheating or through external opposite magnetic forces. Coils can create magnetic field of any strength, but the winding must sustain the current without overheating [21]. Inductive cores can be a squirrel cage or a laminated core. Magnetic field is induced externally through the stator coils (which are almost always present in the body, not in the armature). In the motor, at least one of the field sources must be able to be externally controlled through current. Thus, every motor must have at



least one winding that is controlled externally [18].

Figure 3 shows all general classifications of electric motors in multiple categories. Each category has specific control requirements, construction, technology used, or application. This report focuses on motor types that are used in the transportation industry. Following subcategories of the presented taxonomy are viable for this industry:

1. AC asynchronous polyphase with squirrel cage
2. AC synchronous polyphase with permanent magnets
3. AC synchronous polyphase with synchronous reluctance

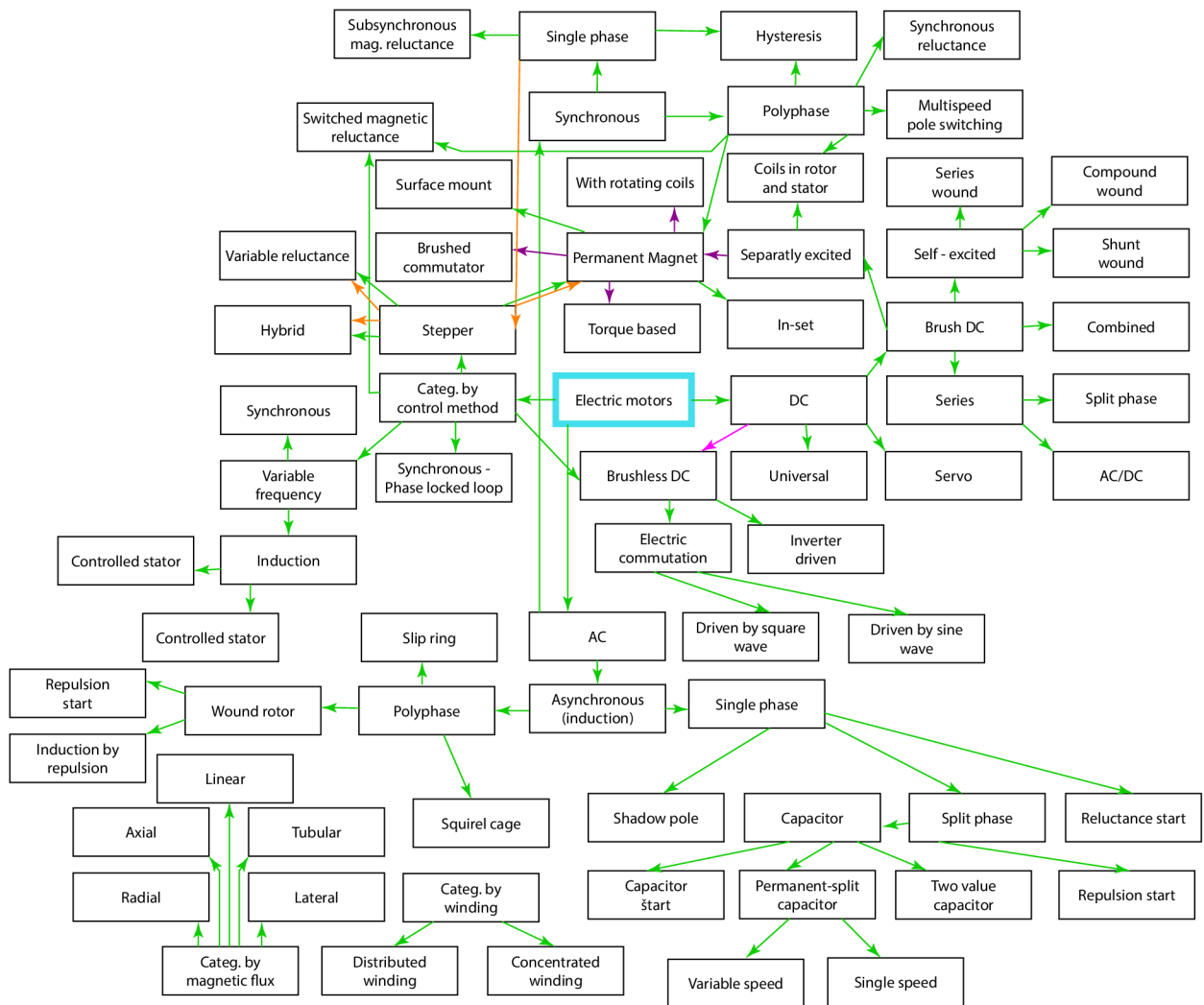

Figure 3: Taxonomy of electric motors

Subcategory number 2 is used in electric scooters. Principle of synchronism is explained later in the report. Synchronous motors with permanent magnets have different abbreviations:

- BPM brushless permanent magnet motor
- BLDC brushless DC motor
- PMDC permanent magnet DC motor
- PMSM permanent magnet synchronous motor
- BPMS brushless permanent magnet synchronous motor
- SPM sinusoidal/surface/synchronous permanent magnet motor
- SPMSM surface permanent magnet synchronous motor
- SMPMSM surface mounted permanent magnet synchronous motor

Abbreviations shown above refer to electric motors with permanent magnets, but some of these abbreviations may refer to more than one type of motors. By convention, BLDC represents trapezoidal motors and PMSM represents sinusoidal ones, within permanent magnet motors [17]. BPMS in this report refers to both of these motors. Sinusoidal and trapezoidal motors are explained later in the report.

### Magnetic flux direction

Electric motors with permanent magnets are classified by magnetic flux direction as radial (Figure 4) and axial (Figure 5) [21]. Other types of magnetic flux direction shown in Figure 3 are not relevant for all types of motors. Motor in electric scooters is commonly named “hub” motor and uses radial magnetic flux. Radial flux is present between the imaginary boundary line of rotor’s permanent magnets and the circle surrounding the stator. Following text will be concerning only motors with radial flux direction.

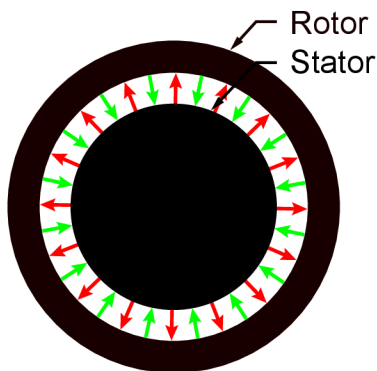

Figure 4: Radial magnetic flux  
Arrows represent orientation of permanent magnet fields in a motor. Their placement against stator creates radial magnetic flux.

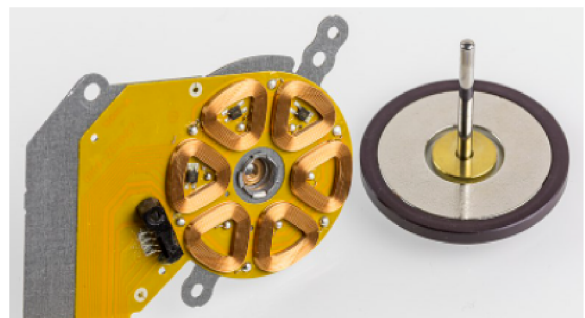

Figure 5: Axial magnetic flux<sup>1</sup>

## Method of commutation

In previously mentioned abbreviations for electric motors, DC, as direct current, is used due to historical reasons. Before electronically commutated motors, brushed DC motors were primarily used [7] [17]. Their control is achieved by sending direct current into two motor terminals. These terminals are connected to a commutator and it delivers the voltage into concrete windings (fig. 6) which are controlled by alternating current. Commutator described is located inside the motors and is made by slip rings and brushes. Thus, these are DC brushed motors. In brushless motors, brush commutator is taken from the motor and is integrated into a motor control unit in the form of switching transistors. Brushless motors, even though they work very similarly to brushed DC motors, are now correctly called AC motors, because commutator in the control unit sends alternating currents to the motor terminals. The rest of the text will be focused on brushless motors.

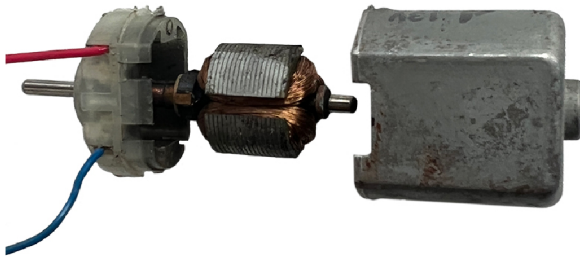

Figure 6: Classic brushed DC motor

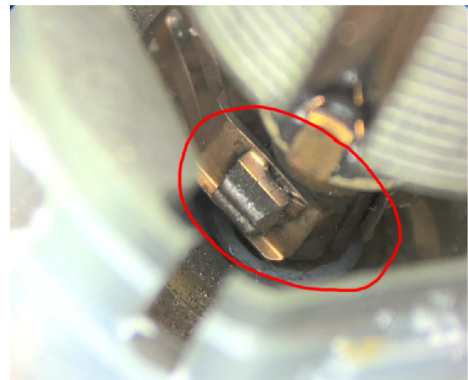

Figure 7: Brush commutator

Commutation names a process where current is switched from one circuit into another. It practically means switching current and its direction between the motor phases. Commutator is a device that during working state of the motor switches current between its phases.

## Location of magnets

It is useful to note the difference between motors with interior and surface-mounted permanent magnets. This difference in motor construction specifies how interaction of fields between rotor and stator happens, and that reflects in motor's control process. Interior placement of magnets adds to their rigidity which allows the motor to reach higher speeds at high torque, as opposed to surface mount magnets which are typically glued onto the rotor [21].

Magnetic field between rotor and stator flows through a magnetic circuit. When magnets are inserted into steel, in the place where steel is replaced by a magnet, there is a lack of steel, because for magnetic circuit, magnet, even though it is the source of magnetic field, has similar properties

---

<sup>1</sup>Source: [https://en.wikipedia.org/wiki/Axial\\_flux\\_motor](https://en.wikipedia.org/wiki/Axial_flux_motor)

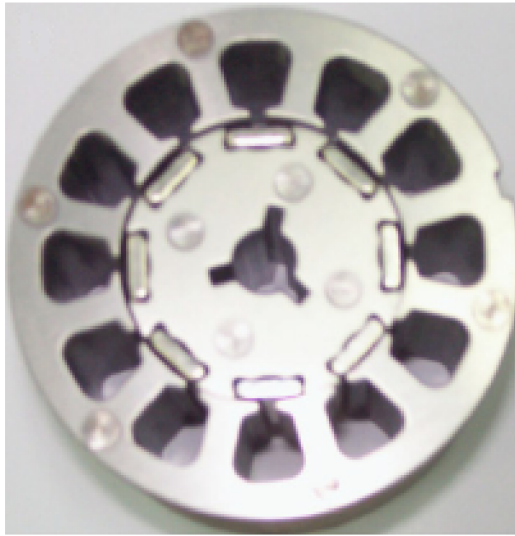

Figure 8: Inset permanent magnets<sup>1</sup>

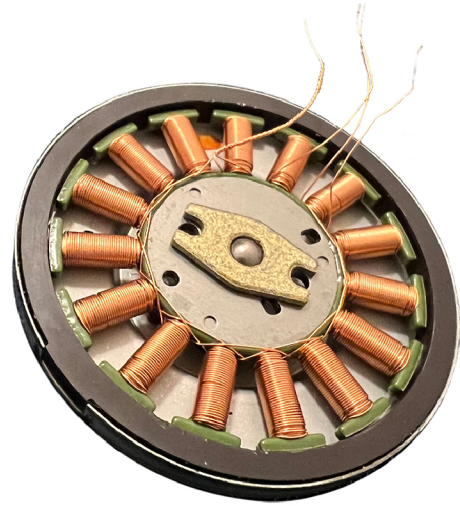

Figure 9: Surface-mounted magnet  
This dark ring is made of slightly flexible material that is polarized in alternating way, even though it is not visible. Similarly as thin magnets on a fridge

to air gap. When stator field flux lines that are closing through the magnet, they flow through less steel than those that close between magnets. This way, they flow through less high permeability material and that results in higher coil inductance on the Q axis that is described later. Inserting magnets into core laminations also increases motor saliency.

### Phase topology

Electric motors in personal vehicles have three phases. These phases can be placed around the stator in different ways, but they are electrically connected in one of the configurations show in Figure 10 [17] [21]. When these phases are modeled, they are rotated by  $2\pi/3$  radians between each other forming a whole circle. Each of the topologies has distinct way of control. Mostly used is the WYE configuration. It is also used in hub motors for electric scooters and this report targets this topology.

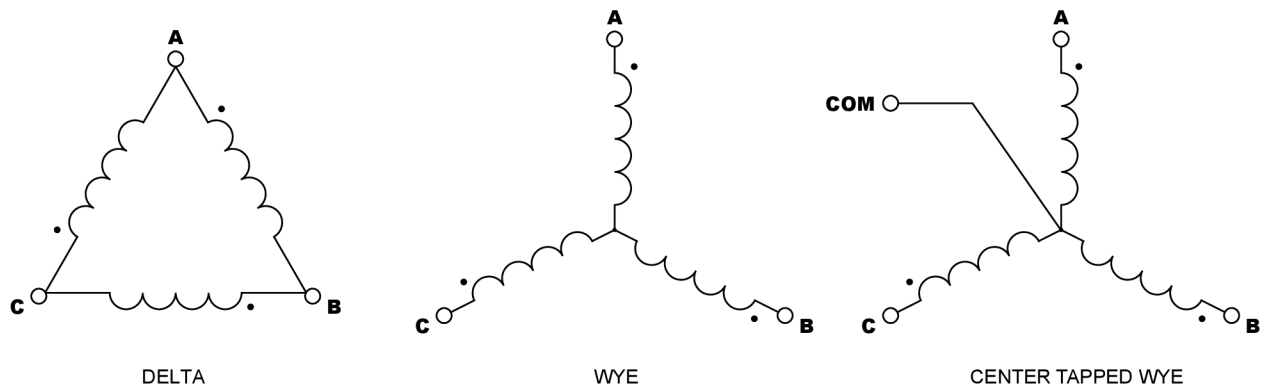

Figure 10: Configurations of three motor phases

## Saliency

Saliency refers to projection of something beyond a general outline. Categorizing electric motors by saliency is useful. Electric motors create torque by fields interaction. If torque is supposed to be fluent, properties of rotor and stator that define the creation of their fields must be as geometrically symmetric as possible and continuously distributed [21]. Salient or non salient can be both armature with shaft, or motor body (so rotor and stator, no matter if it is interior or exterior) [21]. Effect of saliency during motor operation can change, but here, saliency is used for static (without motion/dynamics) categorization of motor. From practical point of view, there is no non-salient rotor or stator. In saliency analysis, magnetic flux generation and magnetic model of the motor is important [17]. Saliency of armature (stator in hub motors) is shown as an example. Magnetic field inside the iron is made by coils. Magnetic field thus travels through different materials, starting with copper where the field is produced, going through the insulation, stator body, air gap, magnets, rotor body, back through magnets, through the air gap and closes through the stator body. For correct analysis of armature flux flow, magnets are taken out, or they are substituted permeability of air. This model simplifies to only two parts - iron and the air gap [17], as is shown in Figure 11. Reluctance (magnetic resistance) is then analyzed. In simplified terms, reluctance of iron is very small compared to that of air, and is therefore neglected. This is how it is possible to make a relatively simple model of magnetic field flow around the whole motor body and analyze its saliency. There is one more effect that is neglected for analysis simplification - flux leakage (described [18]). An example of flux leakage is shown in Figure 12. Thus, it is possible to state the following: Magnetomotive force in coils creates magnetization flux through the metal and the air gap in the motor [17] [21] [18]. It can be seen that the field lines are relatively perpendicular to the curve of motor and stator. Distribution of the field is thus relatively homogeneous and thus the armature is considered to be non-salient.

<sup>1</sup>Source: reference [20]

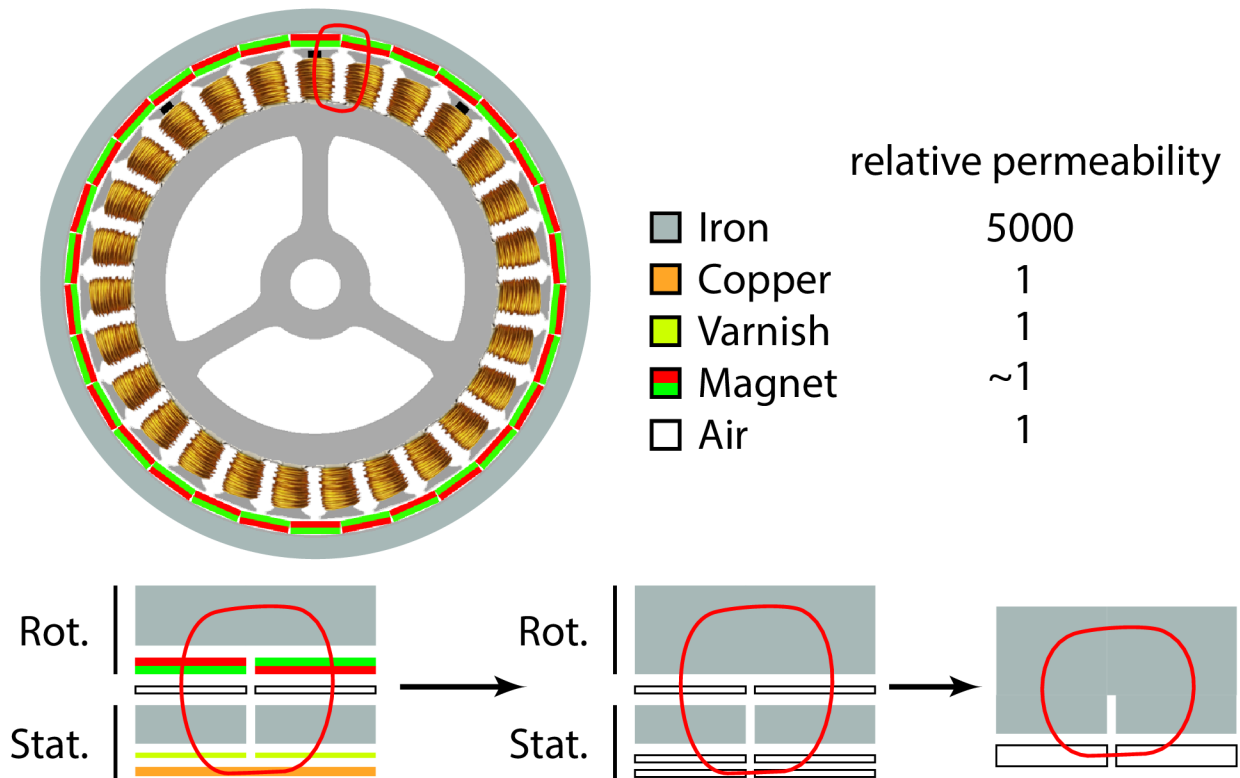

Figure 11: Magnetic field flow of the armature

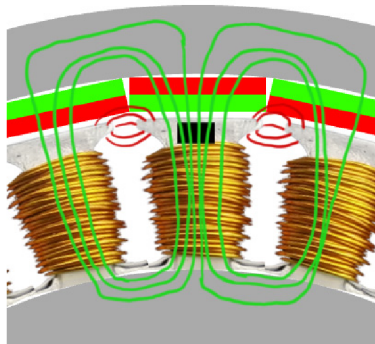

Figure 12: Leakage flux

If rotor and stator is non-salient, motor is non-salient, If rotor or stator is salient, motor is salient. If rotor and stator is salient, motor is doubly-salient.

The less salient the device is (the less magnetic field flow imperfections are neglected), the lower torque ripple it produces with standard way of control, where driving signal is not compensated against possible torque ripple. This signal is usually fully sinusoidal or trapezoidal.

Electric motors can create torque in two ways. First is the use of rotor and stator magnetic fields that interact together (Figure 14). Second is called reluctance torque. When magnetic field (for example that of permanent magnets) of the rotor flows to stator, effect of magnetic resistance (reluctance) appear. Magnetic circuits try to align in a way that minimizes this reluctance (Figure 13) [17] [21]. This holds also true for magnetic field of stator interacting with metal of rotor. Electric

motors create torque only by first effect, by combination of both effects, or only by the second effect. During torque analysis, these two effects can be complicated - torque creation from mutual field interaction and torque creation due to reluctance. Synchronous motors can be salient or non-salient. This holds true for motors with winding in rotor or stator and also for permanent magnet motors.

When the motor is salient, it can create reluctance torque. This is an advantage of salient motors at the expense of reducing smoothness of torque production [21]. Discussed hub motor is non-salient and that is why relatively low torque ripple creation can be expected.

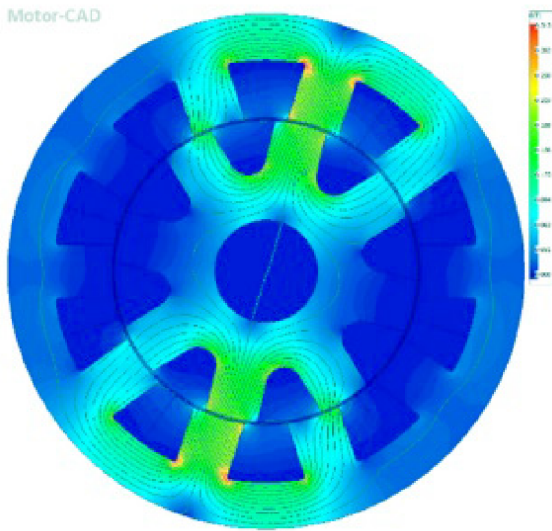

Figure 13: Reluctance effect in a motor<sup>1</sup>

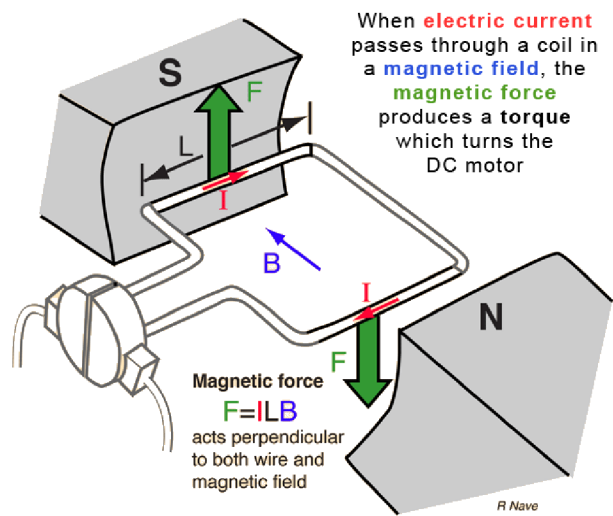

Figure 14: Magnetic effect in a motor<sup>2</sup>

### Sinusoidal and trapezoidal motors

It is very important for axial motors with permanent magnets to determine if they are sinusoidal or trapezoidal. This naming reflects the effect of back-electromotive force (back EMF) induction on the coils from rotating magnets. It also reflect magnetic circuit in the motor [17]. Principles of D and Q axes needed for understanding of this part are explained later.

Construction of sinusoidal motors is made in a way that constant magnetic field of the winding and constant field of permanent magnets in the rotor create during constant rotation sinusoidal forces. Construction of these motors is more difficult, but on the other way, these motors can be controlled very smoothly by driving with sinusoidal currents on the phases [17] [21].

This can be verified by the following series of equations:

$$i_A = -i \cdot \sin(\theta) \quad i_B = -i \cdot \sin(\theta - 120) \quad i_C = -i \cdot \sin(\theta + 120) \quad (1)$$

$$i_\alpha = i_A = -i \cdot \sin(\theta) \quad i_\beta = \frac{i_B - i_C}{\sqrt{3}} = i \cdot \cos(\theta) \quad (2)$$

$$i_D = \cos(\theta) \cdot i_\alpha + \sin(\theta) \cdot i_\beta = 0 \quad i_Q = -\sin(\theta) \cdot i_\alpha + \cos(\theta) \cdot i_\beta = i \quad (3)$$

In the equation 1 are three sinusoidal signals representing current in phases. Each is rotated 120° from the other. By doing a Clarke transform, these currents are transformed to intermediary  $\alpha\beta$  frame of reference. This is shown in equation 2. From this frame they are transformed once again by Park transformation into DQ frame with values in equation 3. It can be seen that the whole current is present only on the Q axis and that way clean torque is produced.

Trapezoidal motors need such signals for fluent control, whose waveform is cancelled with the waveform of ripple in the motor. This way the current portion on the Q axis is maximized [21].

## 2.2 Working principle and modeling of electric motor

In previous text it is shown, that electric motor has many different properties and construction options that have impact on the way how the motor is controlled, and on the quality of produced torque. For verification, the reader should understand these properties of a motor: Brushless, AC, with surface-mount permanent magnets, non-salient, connected in wye configuration with isolated neutral point. Synchronous property will be explained in this section. Here will also be explained, how the electric motor achieves rotation. The principles will be shown by constructing a sinusoidal motor. This is done for simplicity reasons. Principle of trapezoidal motors is very similar, but torque production is little different.

### Creation of torque in a motor

To avoid confusion, the motor that is going to be modeled in this section is shown in Figure 15. Standard hub motor has the armature as a stator with coils. Firstly, the modeled motor will have the winding on the armature, but here the armature is a rotor and magnets that create external field are stationary. This model will later be modified to be closer to the real hub motor.

Loop in Figure 16 a 17 represents a very simplified equivalent of one phase in a motor's rotor. The external magnetic field with density B represents permanent magnets in the stator. Even though the fields of rotor and stator in real motor can be complicated, these magnets and coils can be reduced to an equivalent of one phase and one magnet. Constant current passes through the loop and in both cases there is an opposite force on the two ends of the loop, which contributes to rotation. Forces on the sides of the coils are changing as the loop rotates. They are axial and against

---

<sup>1</sup>Source: reference [22]

<sup>2</sup>Source: <http://hyperphysics.phy-astr.gsu.edu/hbase/magnetic/motdc.html>



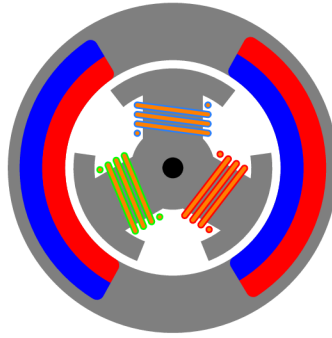

Figure 15: The modeled motor

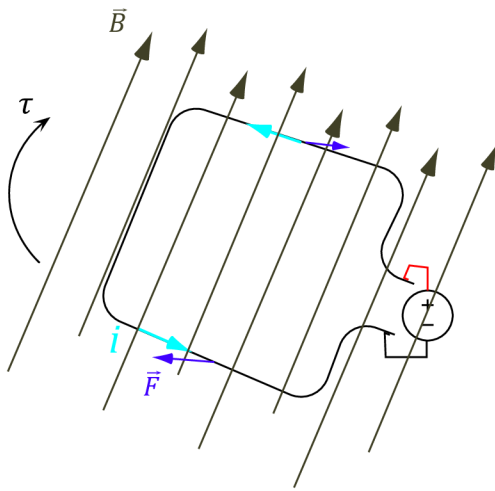

Figure 16: Maximum torque

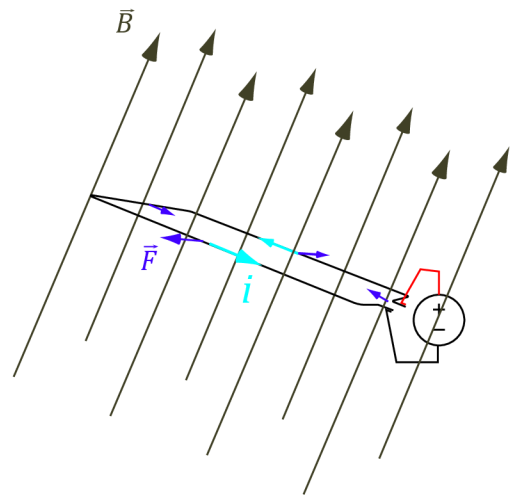

Figure 17: No torque

each other, so they are cancelled out and do not contribute to rotation.

$$\vec{F} = (l \cdot \vec{i}) \times \vec{B} \quad (4)$$

$$\vec{\tau} = w \times \vec{F} \quad (5)$$

$$\vec{\tau} = w \times (l \cdot \vec{i}) \times \vec{B} \quad (6)$$

$$|\vec{A} \cdot \vec{B}| = |\vec{A}| \cdot |\vec{B}| \cdot \sin(\theta) \quad (7)$$

$$\sin(\theta + 90) = \cos(\theta) \quad (8)$$

$$\vec{\tau} = w \cdot i \cdot l \cdot \vec{B} \cdot \cos(\theta) \quad (9)$$

$$\vec{\tau} = A \cdot i \cdot \vec{B} \cdot \cos(\theta) \quad (10)$$

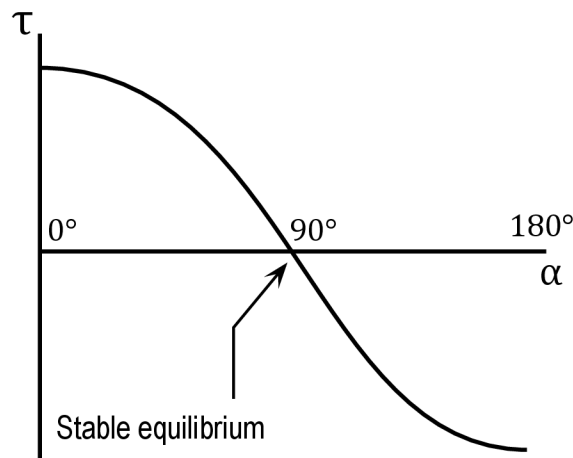

Figure 18: Torque during constant current

Equation 4 states the size and direction of a force on a conductor (loop) with length  $l$  placed into a homogenous magnetic field with density and direction  $\vec{B}$ . Equation 5 states the strength of torque on a loop that is attached on an axis going through the middle of the loop without friction losses. Width of the loop is denoted by  $w$ .  $\vec{F}$  is the repulsive/attractive force on the loop. After substitution of 4 into 5 the result is the expression 6. Loop is placed in the field in a way that the current on the sides flows in the same plane as the external magnetic field plane (width) and the field on the other sides (length) flows perpendicular to the external magnetic field. Figures [16](#) and [17](#) show this placement. This way, the secondary cross product in equation 6 is replaced by multiplication. After substituting 7 and 8 into equation 6, the result is equation 9. Angle  $\theta$  represents the angular position of the loop in the direction of external magnetic field  $\theta = 0$  represents a loop aligned with the field.  $w$  and  $l$ , so width and length, create the area of the loop in the equation 10. Torque during constant current in relation to angular alignment of the loop to the field is shown in Figure [18](#) [17]. It is possible to see, that for the same current it is most efficient to have the loop always aligned with the field, because this way it produces the highest torque for the same current flow.

Loop creates its own magnetic field in the direction or against the direction of the normal vector of the coil's area (so coil behaves like a magnet). This normal vector of the loop area tries to align with the vector of external magnetic field. Goal is to keep this vector aligned perpendicular to the external magnetic field. In motor, external field is rotating, because magnets are turning around the coils. Coils must be energized in a way, that their combined magnetic field is aligned  $90^\circ$  with the field of the permanent magnets that are moving by.

It is important to notice, that while the force in the loop in Figure [16](#) creates torque  $\tau$ , same force on the loop in Figure [17](#) does not create any torque and the loop is in a stable equilibrium.

Only if the loop is turned from the equilibrium by an external force, the torque is exerted on the loop that brings it back to the equilibrium [18].

If the loop is in equilibrium, change of the current in the opposite direction changes the direction of forces on the loop in the opposite direction and the loop gets from stable equilibrium to an unstable one. Any slight deviation in loop rotation causes the loop to swing in the way of deviation to the other side and reaches new stable equilibrium.

This effect of random deviation choosing the turning direction is not wanted in motors, but it is more or less theoretical (for motors with load), because the torque after breaking the balance very small, even if some force is exerted in the opposite direction.

There is a problem with this setup. When the loop is in this equilibrium and the field of the loop is aligned with the external field, no amount of current and change in direction would be able to turn the loop, because no torque is produced. This is the main reason why three phases are used in order to achieve rotation from any position. The phases can be composed of several coils wound around the rotor, and they are separated by  $1/3 \cdot 2\pi$  angular radians from each other, spanning together the whole circle. This means that each phase creates its own magnetic field  $120^\circ$  apart from the other two (Figure 19).

When a constant external field acts on these three phases as shown in Figure 20 and a current flows through them, after turning the whole group of phases by an angle  $\alpha$ , each of those phases feels a torque shown in Figure 21 [18].

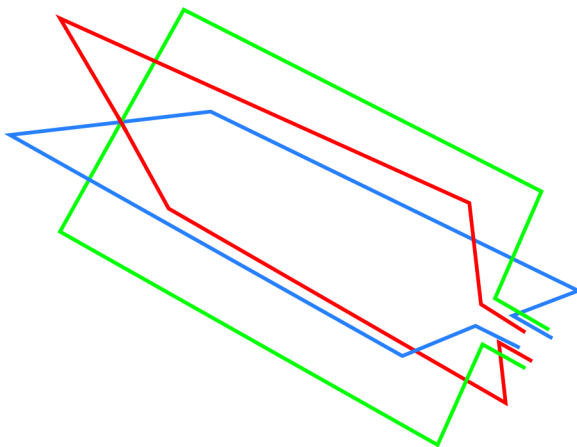

Figure 19: Phases 3D

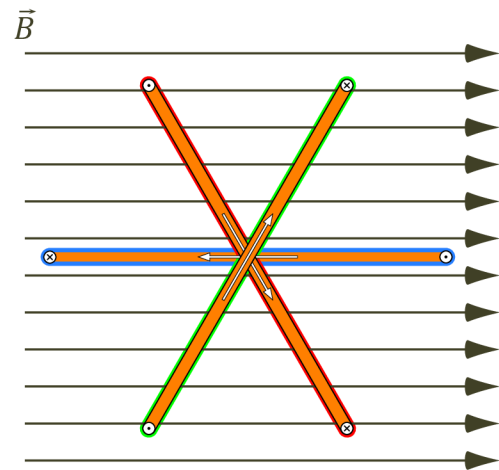

Figure 20: Phases 2D

Phase has two terminals. A and B. All phases have terminal B connected to form a common point. When the current flows into a phase through terminal A, phase creates force and torque normally. When it leaves the other terminal of another phase, that other phase creates torque and forces in the opposite direction. Phases connected in WYE configuration are always controlled two

or three at a time. The other phase then creates a field in opposite direction than it normally would, if current was entering its A terminal, not leaving. This effect is welcome as the reverse phase is appending to the field of the forward phase and the two phases are working together. Current is always sent into the A terminal of a phase that generates a positive torque. Phase right next to it would generate negative torque, but because of the field inversion, the torque is positive on both phases [17]. Last phase is either not connected (A terminal is not connected to any potential) or it is driven to achieve precise field control. With the right way of time commutation, it is possible to achieve torque of the external field to the winding as indicated by the black arrow in Figure 22.

Resulting production of torque in Figure 22 is not smooth. Ideal would be a straight line. Non-linear change of torque is called torque ripple [21] [18].

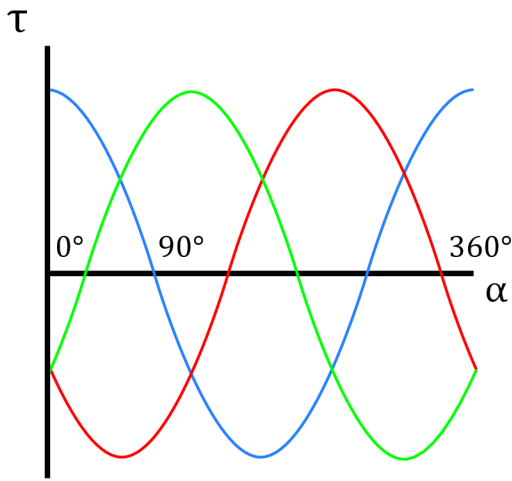

Figure 21: Torque on each phase

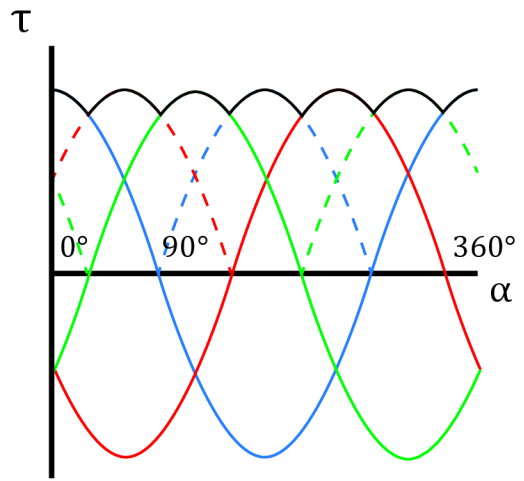

Figure 22: Production of torque in WYE configuration

$$\tau_{avg} \propto i \cdot w \cdot l \cdot B \cdot N \quad (11)$$

$$\tau_{avg} \propto i \cdot K_{\tau} \quad (12)$$

Average torque is directly proportional to the current through phases  $i$ , length and width of the conductors in the coils ( $w, l$ ), permanent magnetic field density ( $B$ ) and a number of turns of the coils  $N$ . This is shown in expression 11. Current is the only variable that can be controlled by the designer of control system [18]. All the other quantities are under control of motor manufacturer, and they represent a torque constant of the motor.

$$\Delta U = Q - W \quad (13)$$

$$P = V \cdot i \quad (14)$$

$$P = \tau \cdot \omega \quad (15)$$

$$\varepsilon \cdot i = \omega \cdot \tau \quad (16)$$

$$\varepsilon = \omega \cdot K_{\tau} \quad (17)$$

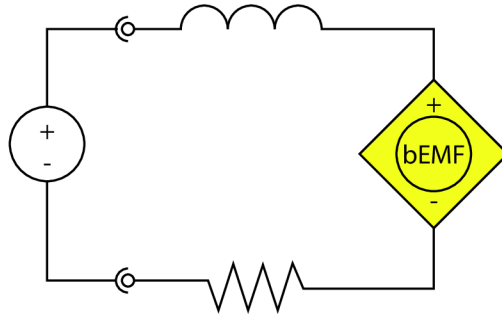

Figure 23: Electrical model of one phase

The electric model in Figure 23 is an equivalent to one motor phase that is connected to the supply voltage. Coil models the state, where change of current through the coil is gradual, rather than instant. Resistor models electrical losses in the system and the block colored in yellow models interaction of a phase with the external field, which produces back-EMF and is bound with torque.

1st law of thermodynamic states that energy in the system stays constant. In equation 13, change of the energies of the system ( $\Delta U$ ) is equal to the heat that got into the system, with negative of the work produced by the system ( $-W$ ). From the point of yellow system in Figure 23 quantity  $Q$  is not present. Loss is present on the resistor.

Equation 14 states that work produced by a system is equal to the difference of voltage on the (electrical) system and current passing through the system. In case of the yellow system in Figure 23, electric power is transformed into mechanical power by the current multiplied with back-EMF induced on the coils. From mechanical point of view, the power is produced as says the equation 15 [18], where  $\tau$  is the torque multiplied by angular speed of the motor  $\omega$ . Modified equation 14 where  $V$  is substituted by  $\varepsilon$ , and that is substituted into 15 creates relation 16 After substitution of torque  $\tau$  from equation 12 and current cancelling out, 17 is the resulting expression.

Expression 16 states, the faster the motor turns, the back-EMF on the winding rises. This voltage is subtracted from the supply voltage, which falls down due to this effect. Motor can get to a point, where induced voltage is equal to that of supply voltage and supply is no longer able to create current

to further increase the speed.

$$\tau_{avg} \propto i \quad (18)$$

$$\omega \propto V \quad (19)$$

$$Torque = \frac{3}{2} \cdot \frac{P}{2} \cdot [\alpha_{Drot} \cdot I_{Qstat}]' \quad (20)$$

Equation 20 states that the resulting torque on a rotor is equal to the number of poles  $P/2$  (where for example, in Figure 38, there are 8 poles), and to the product of magnetic flux in the D axis  $\alpha_{Drot}$  with current portion going through the Q axis  $I_{Qstat}$ .

In conclusion, magnitude of the torque is dependent on the current through the phases (expression 18) and speed is dependent on the voltage on the phases (expression 19) [21]. Of course the voltage on the phase terminals in the end controls the current which does the final effect. The goal is to keep the controlled field leading and perpendicular to the external field. Since the magnetic field of the stator is always aligned in the same way as the angular position changes, and speed of the rotating field is the same as speed of the rotor (from rotor's point of view), these quantities are synchronized. This is why this kind of motor is called synchronous [18]. Synchronism has an advantage, that by knowing the magnetic field density on the stator, its angular position (needed for the means of motor control) can be determined. Induction motors are asynchronous.

Winding of the motor also works as a low-pass filter [18]. Thanks to this property, current for the phases can be modulated on a high-frequency switching waveform and motor smoothens the waveform by integrating this high frequency. This way, other kinds of current waveforms can be achieved on the motor, such as sinusoidal, and motor can be precisely controlled only by binary switching in time.

### **Model modification for stationary winding**

In the section above, principles of electric motor function are explained on a motor with stationary magnets and rotating windings. In real hub motors, winding is stationary and magnets are rotating. To keep the simplicity of the model, magnets will be substituted by one equivalent cylindrical magnet and it will be placed to the middle of the motor (as the armature) and winding will be in the body of the motor.

Magnetic interaction functions in the same way here, as in the model above. If the magnetic field of the magnet is aligned  $90^\circ$  to that of the coils, most efficient torque is achieved. This is shown in Figure 24 and it is analogous to Figure 16. Force is exerted on the magnet and it tries to orient in a

way that its magnetic field goes in the same direction as the external field of coils. This is visualized in Figure 25 and it describes the same situation as Figure 17 in the model in above section.

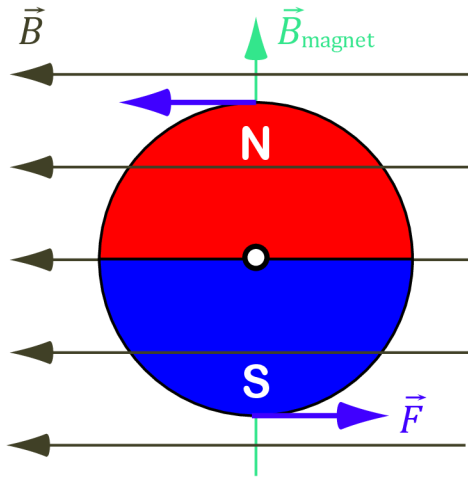

Figure 24: Magnet with maximum torque

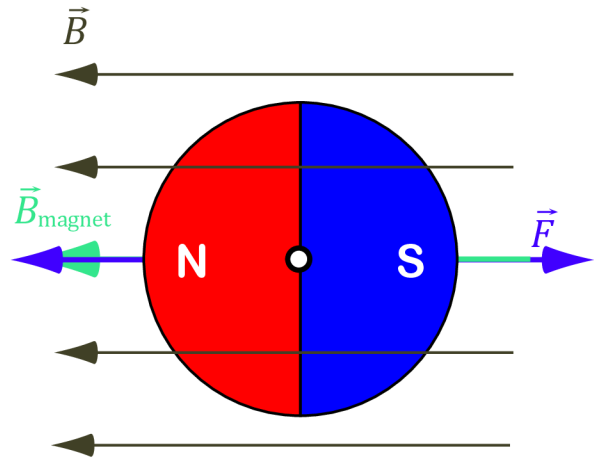

Figure 25: Magnet with minimum torque

Modified model for rotating magnet is shown in Figure 26. Figure 27 shows the following: Current flows into phase C and comes out from phase B. Phase A is disconnected. Phase C creates a magnetic field in a normal way and phase B in reverse, because current flows out of its terminal. Both phases work together. Fields of the magnet and coils interact between each other. Force is exerted on the coils (phases). Force creates torque. Magnet feels the force in the opposite direction. Coils are in the stator and they don't move. This is why the magnet in the rotor starts to turn.

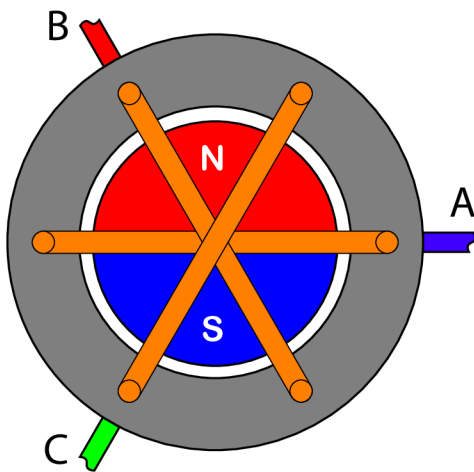

Figure 26: Modified model of the rotor

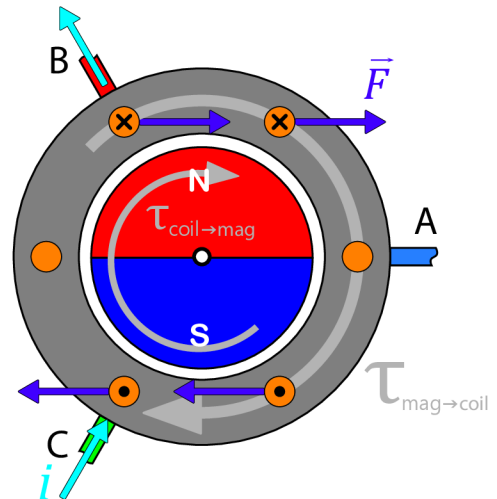

Figure 27: Principle of torque production

For clarification, same scenario is shown in Figure 28. Here however, direction of magnetic field an external field of coils is shown. See the 90° angle between the fields. This means, that in this state, the magnet starts to rotate with maximum torque.

Model of the motor with one loop for one phase is simple to understand, but it is not realistic.

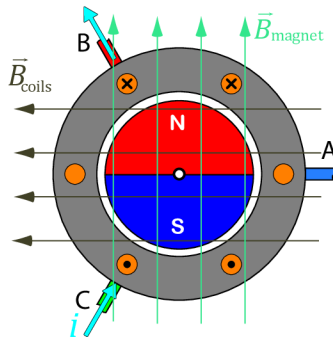

Figure 28: Rotor and stator fields inside motor

This is why in Figure 29 an equivalent of a motor with actual windings is shown

Current and current induced magnetic field are now interconnected. In this model, between the direction of current and direction of magnetic field is 90° difference. Figure 30 represents the contribution of each of the three phases to the torque [18]. Figure 30 shows a situation, where by turning the two phases on, resulting combined vector is formed. This principle is a foundation for the ability to set the resulting induced field to any direction and strength by controlling current through the three phases [18]. The notation of current direction is not used, and here it is only to show the modeled principle. In textbooks, current vector is identical with the induced magnetic field vector. Motor with loops is not ideal to be connected with this convention, but closer visualization is the motor with coils shown in Figure 29.

It is clear from Figure 27, that the torque produced by the coils on the magnet is in the opposite direction than the torque produced by the magnets on the coils. Figure 22 shows torque of an external field onto rotating coils. Figure 31 shows torque produced by the stationary coils onto the rotating magnets. This is why the torque of all the phases is flipped as opposed to the previous Figure. Initial state, where the angular position is 0, is shown on the first part of Figure 29. Now, the reference frame is as follows: angular rotation of the coils is constant and external magnetic field is in motion with the magnet that creates it.

### Principle of motor current switching

Phase is powered from the power source, as seen in Figure 23. Also, the polarity of every phase terminal must be controlled. In WYE configuration, at least two phases are connected at a time. Thus, the diagram of phases connected to switching circuitry is shown here:

For simplification, Figure 32 shows only control of arbitrary two phases. The other one is neglected.

Switching cycle of the motor is divided into two phases. In the first one the phases are connected to the battery and energy flows to the motor. Phases are inductors as shown in Figure 23



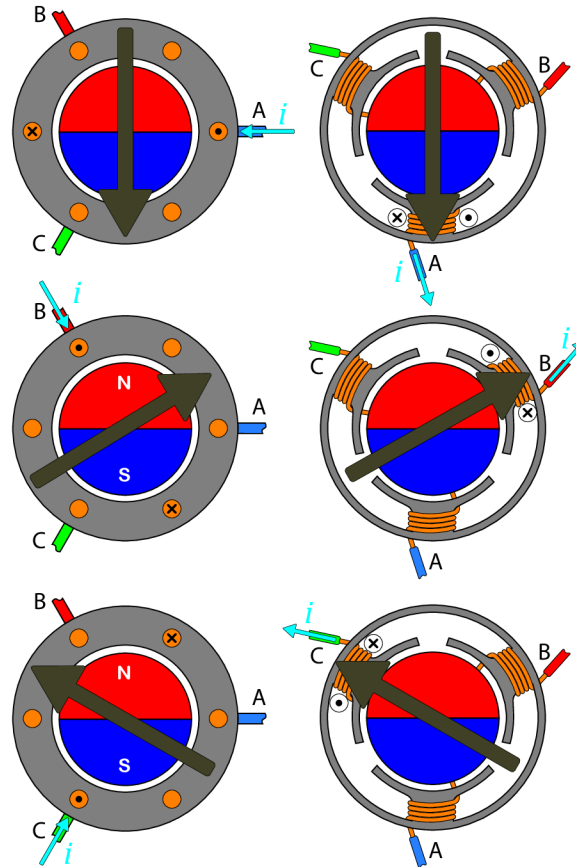

Figure 29: Model of motor with coils

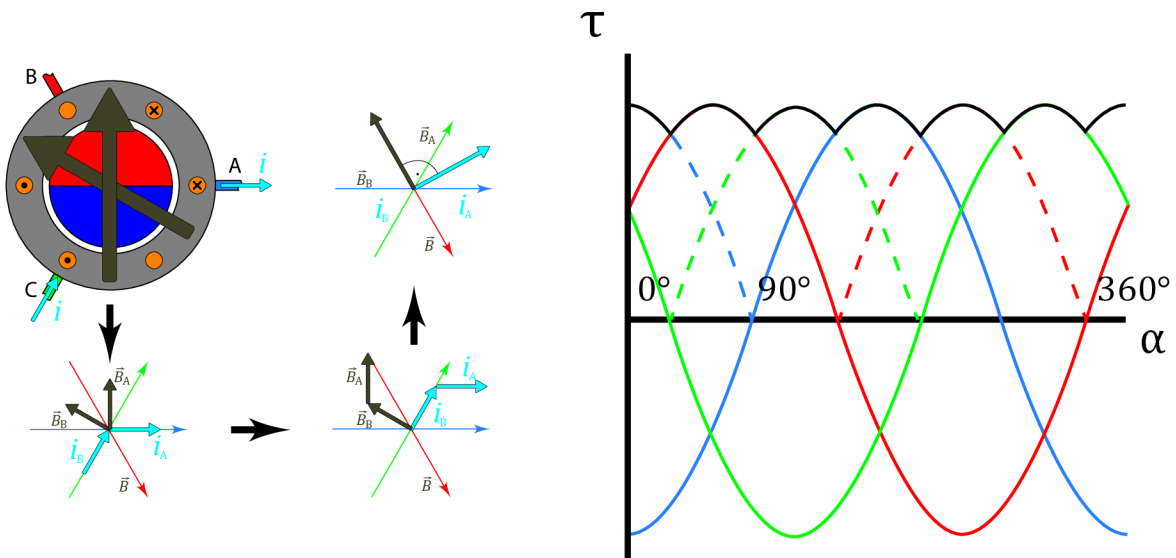

Figure 30: Vector combination

Figure 31: Torque of windings on magnet

and current flowing through them is rising continually [25]. In the second phase, the energy supply is disconnected from the motor and the current must continually decay. Switching elements have an integrated body diode, which is part of their construction. Current during dead time is slowly

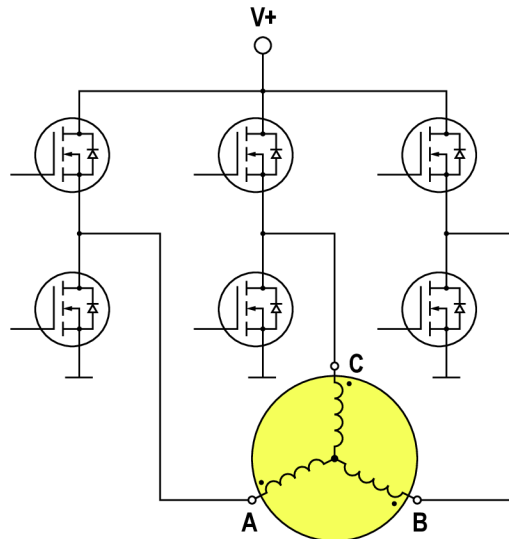

Figure 32: Switching elements on the phases

reducing and flows in one of three possible paths. These paths are shown in Figure 33.

In the first case (Hard switching), the current flows through the battery and charges is. This is the case of regenerative braking. During this, motor is slowed down, because the law of energy conservation holds. Motor transforms kinetic energy to electric, working as a generator. This method is therefore viable only during regenerative braking and not during normal operation.

During soft switching, current is switched through the right low-side switcher. The current flows down and back up through the left switcher's construction diode into the motor, closing the circuit. This method is acceptable, but there are losses associated with the body diode of the left switcher, since the diode has a voltage drop across it and thus it dissipates power. Current times the voltage drop equals the dissipated power during this cycle [25].

Last method (Complementary switching), changes body diode losses for the switching losses, which are notably lower. This method of dead time is preferred.

### Modification of control signal

When the motor is controlled by sinusoidal waveforms, a problem emerges, that at any time, the full power supply potential is not used. This problem is illustrated in Figure 34. Figure 35 shows a process where the amplitude of the sinusoidal waveforms are offset by as much as the DC equivalent of this waveform differs from the supply voltage. Then, a triangle wave is added to this waveform, resulting in signal shown in Figure 36. This modified waveform is equivalent to the original waveform, but the effective amplitude now reaches the supply voltage. This waveform can be pulse-modulated onto the motor phases. Multiple shapes of switching waveform exist and each of them is optimized for some parameter, efficiency for example. These signals are created using space vector modulation

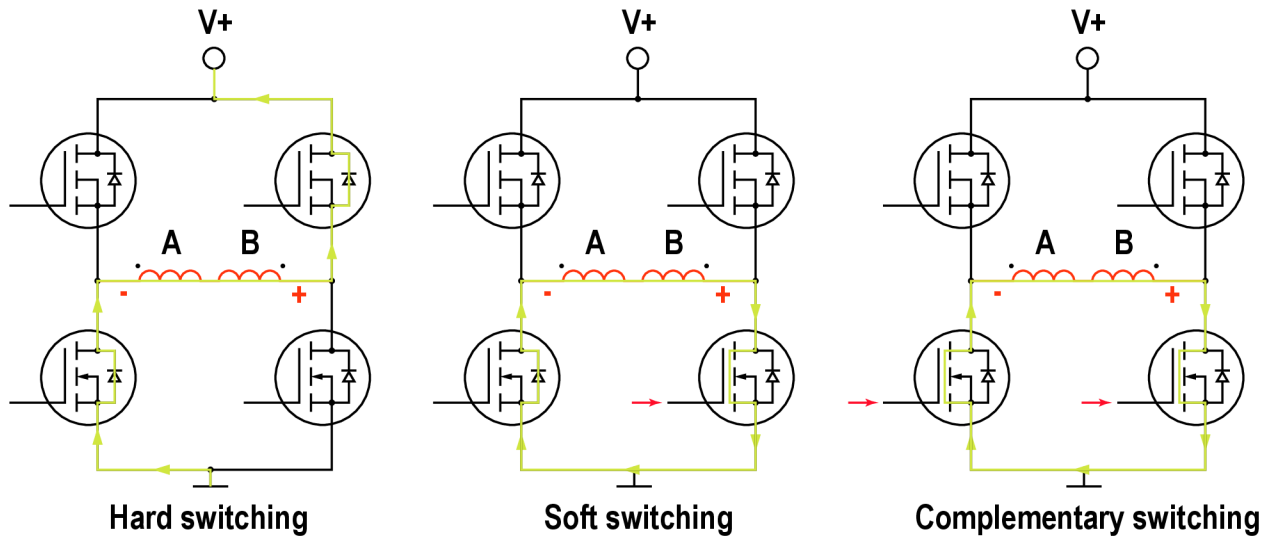

Figure 33: Switching options during dead time

[25].

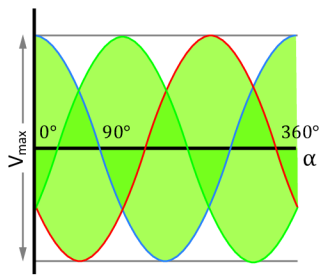

Figure 34: Problem

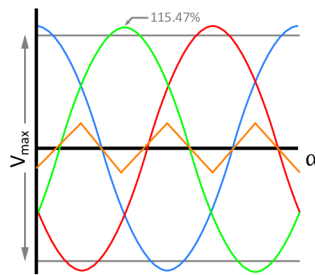

Figure 35: Modification

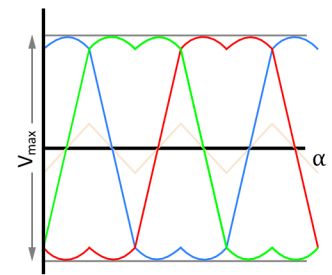

Figure 36: Result

## 2.3 Electric motor control

Control of BPMS motor is non-trivial. When an incorrect driving method is used, these problems can emerge:

- Inefficient production of forces, which heats up the motor.
- Creation of torque ripple.
- Louder motor operation.
- Excessive stress on the controller or battery.

Because of this, the electric motor, whether induction, servo, or synchronous, are modeled and parameters of these models are implemented into a control system, for more efficient motor control.

There are two main types of motor (taking into account the narrowed spectrum from the text

above) and two corresponding motor control techniques. BLDC trapezoidal motor, which uses so-called six-sector commutation, and a SMPS sinusoidal motor, that uses mainly field oriented control method (FOC) to drive the motor. Technically it is possible to drive the trapezoidal motor using FOC, which could decrease torque ripple and increase efficiency.

### 6 sector commutation

The goal of six-sector commutation is to replace the brush commutator with an electric one. This commutation requires the knowledge of rotor's position [25]. The position in BLDC motors is mainly detected using hall sensors, which are placed in the magnetic circuit to measure 120° changes between each other [17].

Principle of the hall effect sensor is following: Through the sensor's plate a constant current is flowing, which is by the forces described by Lorentz, acting on the charged particles, they are deflected in the presence of an external magnetic field. This deflection creates a voltage difference between the points of measurement. Practically a hall sensor contains integrated operational amplifier, that amplifies this effect.

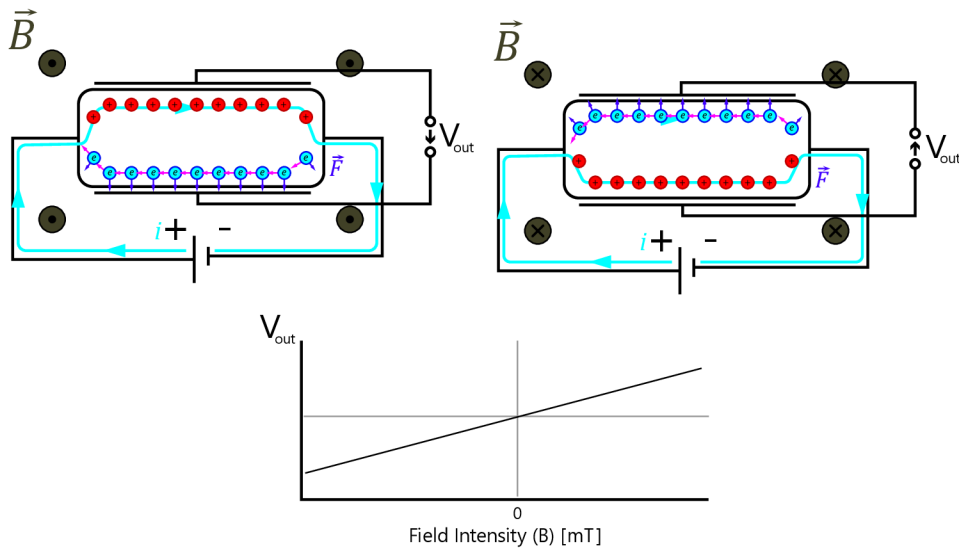

Figure 37: Hall effect principle

Hall sensors are placed in the modeled Figure 38 in a way, that allows to break the of the rotor's field into six sectors. This rule is shown in Figure 39 as well, where a property of motor symmetry is used, and still only three sensors are necessary.

Hall effect sensors have a problem that the voltage representing the field strength fluctuates with temperature [25]. In motor control applications the hall effect measurement range show in Figure 37 is discretized into binary values '0' a '1', that change at the edge of two magnets [25]. 0 means that the south pole is facing the sensor and 1 means the north pole is facing the sensor.

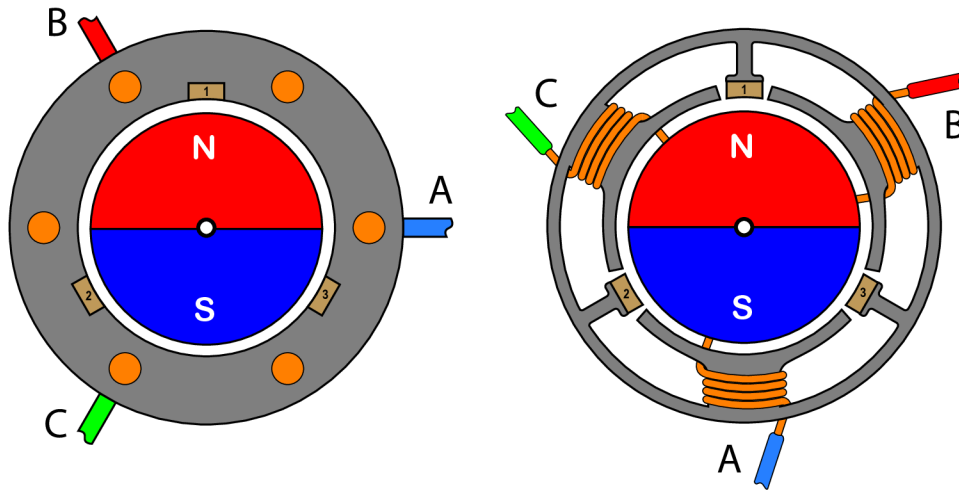

Figure 38: Placement of hall effect sensors

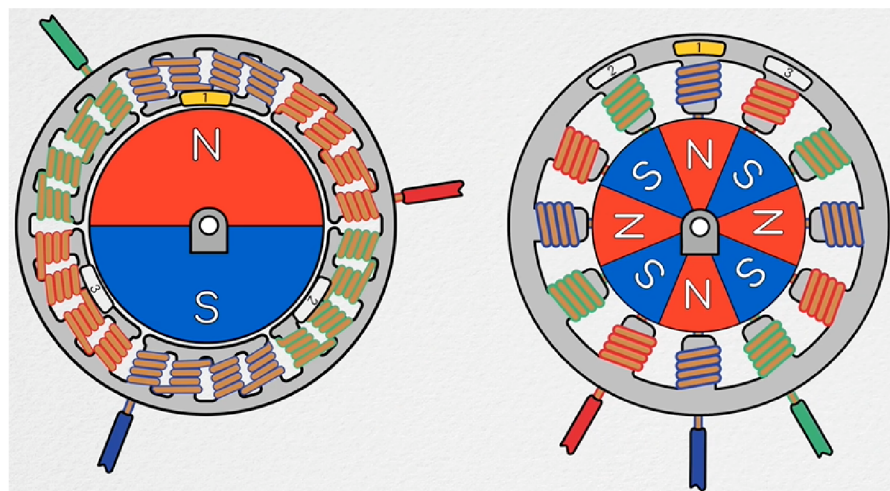

Figure 39: Winding possibilities<sup>1</sup>

Transition between these values indicates a sector change for the microcontroller [19].

As was mentioned in previous sections, most efficient torque production happens when the field of the winding leads the field of the permanent magnets by 90 degrees. Control consists of the following steps:

1. Change of sector has been detected.
2. Detect, which two phases create 90° field alignment to the field of the magnets.
3. Switch the current to those phases to sustain speed

For the step 2, a regular lookup table is used, which maps the best combination of phases for each sector [25] [19].

<sup>1</sup><https://youtube.com/watch?v=RN1SFSgz-Co>

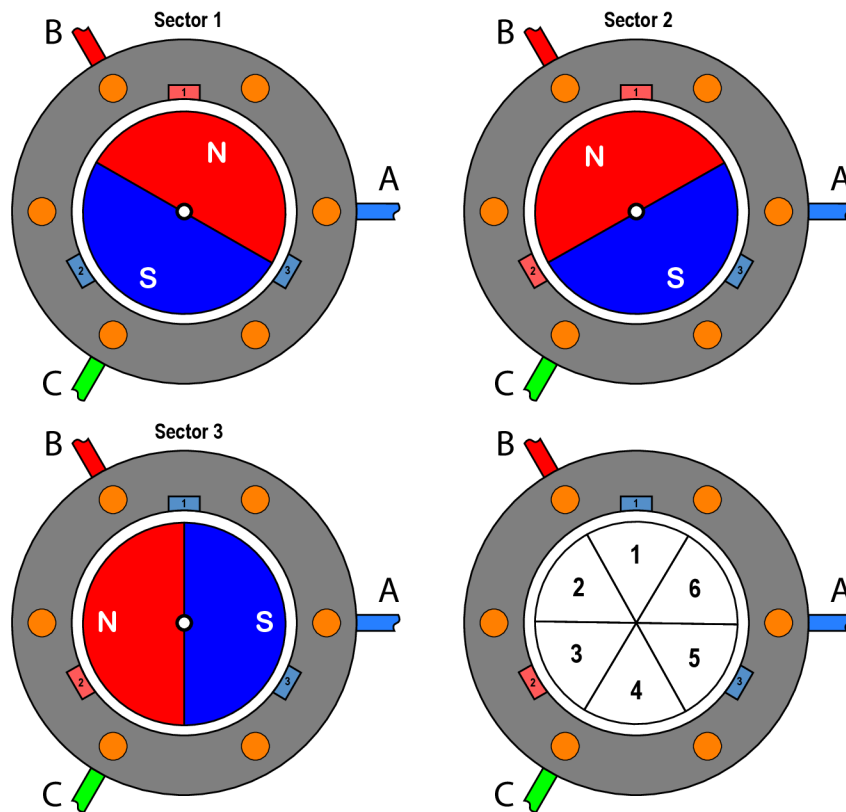

Figure 40: Sectors in a motor

On the left side of Figure 42 a visualization of motor is presented, that is simulated on the right. On the next Figure, some steps of the six-sector commutation. Light blue arrows indicate the direction of the magnetic field created by the rotating magnets. Pink arrow indicates the resulting direction of stator magnetic field, which is equivalent to the current 'direction' flowing in the phases. This current and magnetic field is a result of three current parts, each of one phase.

This method works and motor can turn, however not very efficiently. Angular width of one sector is  $60^\circ$  in this case. As motor rotates through the sector, magnet is ideally (with  $90^\circ$  offset) oriented only at one point in the sector. This creates torque ripple shown in Figure 31 (for sinusoidal motors). From the simulation samples it can be seen, that the  $90^\circ$  angle is achieved when the field of the magnets is in the middle of the sector.

### D and Q axis

Electric motor with permanent magnets has two described axes. One goes from the middle of the motor to the center of a magnet. This is called a direct axis designated with letter D. Quadrature, Q axis, goes from the center between the magnets, without touching one. Normally these axes describe a model which has magnets laid out in a motor in such a way (example in fig. 39 right), that these axes can be drawn  $90^\circ$  from each other. Q axis leads the D axis. Figure 44 represents

	hall 1			hall 2			invalid	
Hall	100	110	010	011	001	101	000	111
Sector	1	2	3	4	5	6	-	-
High	B	A	A	C	C	B		
Ground	C	C	B	B	A	A		

TURNING LEFT

Hall	100	110	010	011	001	101	000	111
Sector	1	2	3	4	5	6	-	-
High	B	A	A	C	C	B		
Ground	C	C	B	B	A	A		

TURNING RIGHT

Figure 41: Hall lookup table

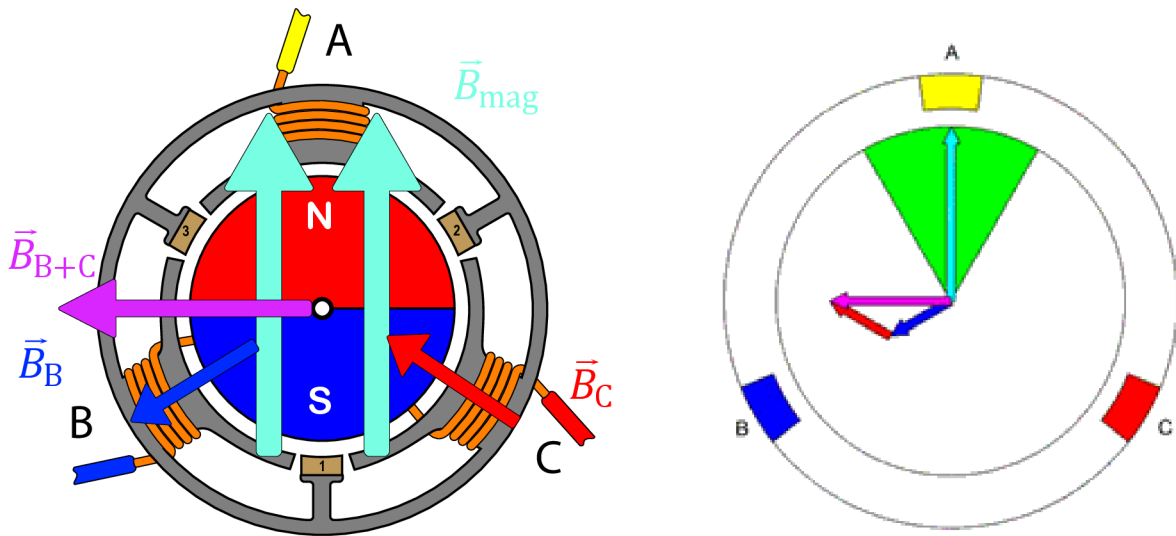

Figure 42: Example of motor and six-sector model

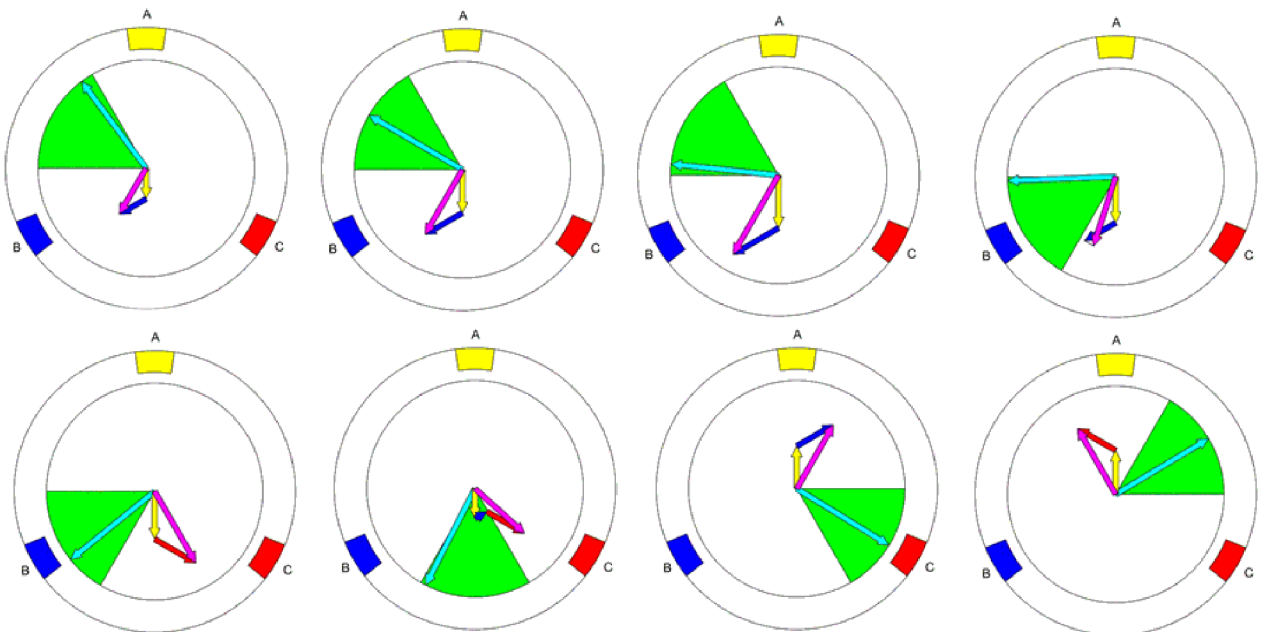

Figure 43: Simulation of six-sector commutation<sup>1</sup>

placement of the D and Q axis on a rotor.

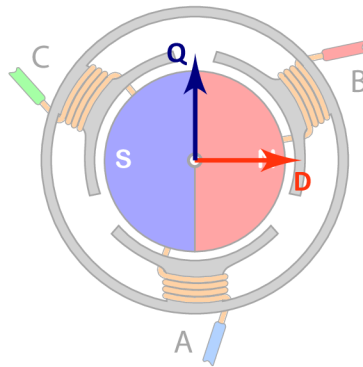

Figure 44: DQ axes placed on a rotor

D and Q axis rotates with the magnet (with the rotor), so they always represent themselves correctly.

If the stator creates magnetic field onto magnets in the direction of D axis, this field will strengthen the magnetic field of the permanent magnet [18]. If the field goes in the opposite direction of D axis, it weakens the magnet's field. Magnetic field opposing the D axis should not be too high, otherwise the magnet can weaken or demagnetize [19]. Principle of life cycle of permanent magnet is shown in appendix A.

Magnetic field in the direction of Q axis creates counter-clockwise torque. Field in the opposite direction creates clockwise torque. Magnetic field created against the magnets field is ideal in the direction of this axis (it is 90° offset from the field of permanent magnets). It is therefore desired that the current and magnetic field created by it, flows in the direction of Q axis [18].

Normally, the motor is controlled by pushing current through three phases. The goal is to calculate the demanded current in the DQ reference frame, transform that frame into intermediate  $\alpha\beta$  frame and finally transform that one into ABC reference frame, where the individual components represent current for each phase. Transformation between these frames are done using Clarke and Park transforms [18]. Principles of these transforms are described in appendix B and C.

Current on D and Q axis during six-sector commutation is visualized below.

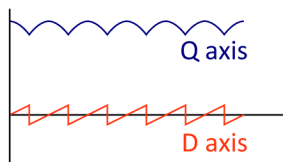

Figure 45: Currents on D and Q axes during 6-step commutation

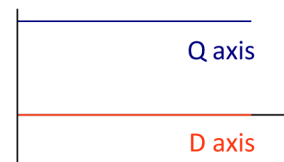

Figure 46: Ideal currents on the D and Q axes

If the magnets are inset into the rotor, in the magnetic circuit point of view, the location of the

<sup>0</sup><https://www.utmel.com/blog/categories/motors/what-is-brushless-dc-motors-blcd>



permanent magnets behaves like an air gap. Therefore, the Q axis is longer than the D axis. The Q axis goes from the center of the motor to the beginning of the rotor's iron (in hub motors, where rotor is in the motor body). The D axis goes from the center of the motor to the beginning of the magnet. If the Q axis is longer than the D axis, the inductance on these two axes is different and reluctance torque is present. D-axis induction is induction of the coil going through the magnetic pole and Q-axis induction is an induction between magnetic poles. If these two inductances are comparable ( $L_d \approx L_q$ ), the inductance values measured at the motor terminals are the same during any motor position [19].

In order to create torque in the motor, it is necessary for magnetic flux of rotor and stator to link [19] [17] [18]. This is a result of magnetic field lines passing through the material in a closed loop as shown in figure 11. The material through which the field passes can saturate and when even larger current passes through the phases, the core cannot link more flux lines. As a result, the inductance reduces, which reflects in D and Q axis induction.

## Field Oriented Control

This technique solves the problem of torque ripple, which arises in six-sector commutation. It is a sophisticated technique that increases motor efficiency and reduces operating noise. It is mainly used on motors with sinusoidal back-EMF. To perform field oriented control (FOC), controller must know the rotor position. Position can be detected by resolver, encoder, hall sensors, high frequency injection technique, or it can be calculated from the strength of the back-EMF (observer). The last two methods are classified as sensorless [19].

The encoder is subject to quantization errors at a slow motor speed - the encoder counter does not detect a change from such a small rotation change. Hall sensors are only suitable for analog field measurements (for FOC) and they can detect only local field changes, not the general rotor position. The observer is a complex system but it can well reconstruct the position of the motor from the signals that arise in the motor. It is therefore a sensorless way of detecting motor position.

The basic principle of current control in FOC is as follows: Current in two phases is measured and the third one is calculated. These current magnitudes are moved to the ABC frame. From these three vectors, the resulting vector in the  $\alpha\beta$  intermediate frame is created using the Clarke transformation. Angular position is measured or estimated, and it is stored in a variable  $\theta$ . The vector from the  $\alpha\beta$  frame is transformed into the DQ frame by Park transformation using angle  $\theta$ . D and Q current components are compared to the desired values. Usually, the desired values are  $D=0$  and  $Q=\text{required torque}$ .

The difference between the measured D component and the D required value is the error deviation. The error deviation is amplified in the PI controller. A derivative term is not required unless

a phase deviation occurs in the controlled system. The figure 47 shows a control diagram whose input is a reference value with a deviation and the output is a newly commanded voltage for the D axis. Same diagram would represent a control system whose output is a voltage for Q axis.

For the requirements of control it is only necessary to measure current on two phases. But by measuring current on all three phases and comparing them to the calculated values (calculated using Kirchhoff's law), current leakage can be detected.

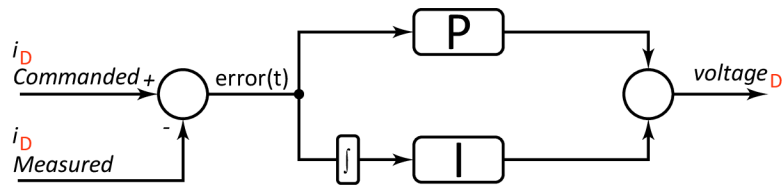

Figure 47: Control diagram for the D axis

If the Park Transform was not used, only the Clarke Transform, the current in alpha axis would be cosine and in beta would be sinusoidal. These harmonic waveforms should be compared to a reference value. By park transformation, the harmonic components are canceled and a one-way DC signal remains, which is easier to compare.

These two new values of voltage need to be transferred to the motor phases. Firstly, the new commanded voltages on the D and Q axes are transformed by the inverse Park Transform to the  $\alpha\beta$  intermediary frame (fig. 48). Then, individual values for the phases are obtained by the inverse Clarke transformation, which are pulse modulated into the switching system [19].

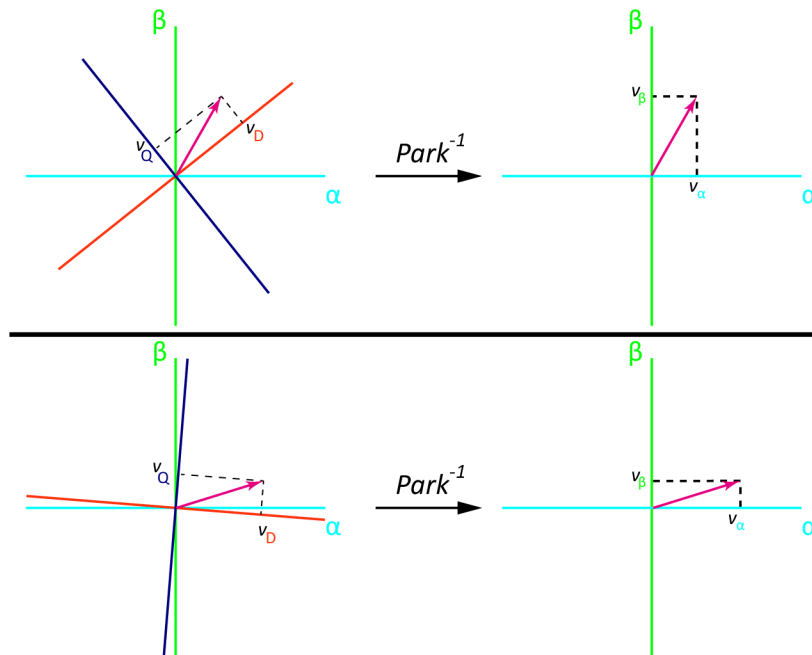

Figure 48: Example of inverse Park transform

The diagram in Figure 47 shows a parallel PI controller. This type of controller may introduce

a difference in frequency response of the transform function for this system. The use of a serial PI controller (Figure 50) allows to control the zero point on the system transfer function, which contributes to the stability of the control system.

Control structures can be cascaded. An example is shown in Figure 49. The system is designed by taking the most nested loop, doing a stability analysis with open loop parameters on this loop and then integrating it into another as a closed transfer function. The process is repeated until the top control loop [18]. In the case of the control system shown in Figure 49, it is necessary that the torque loop has the highest bandwidth of all the loops. This means that it measures the values the fastest and has the fastest response to changes.

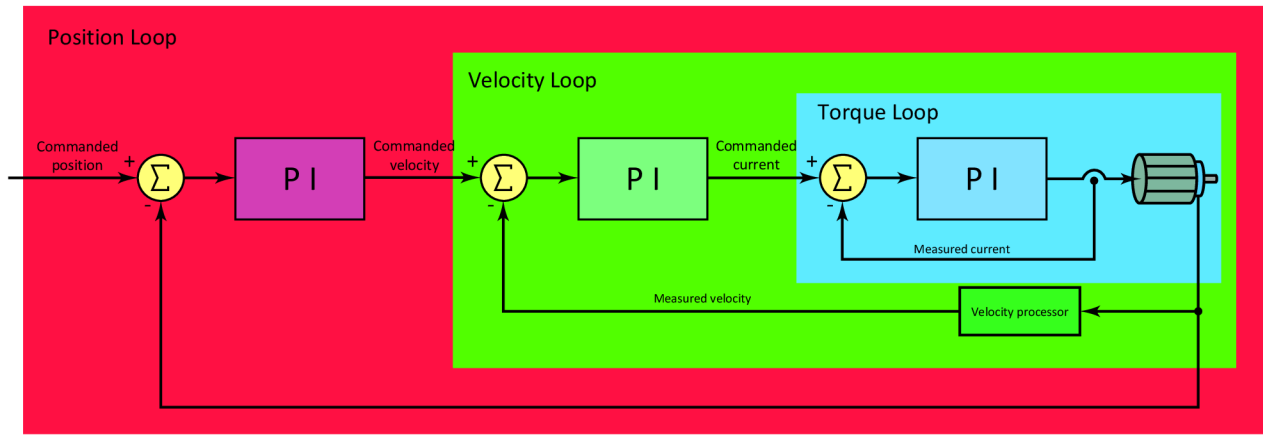

Figure 49: Cascading of control structures

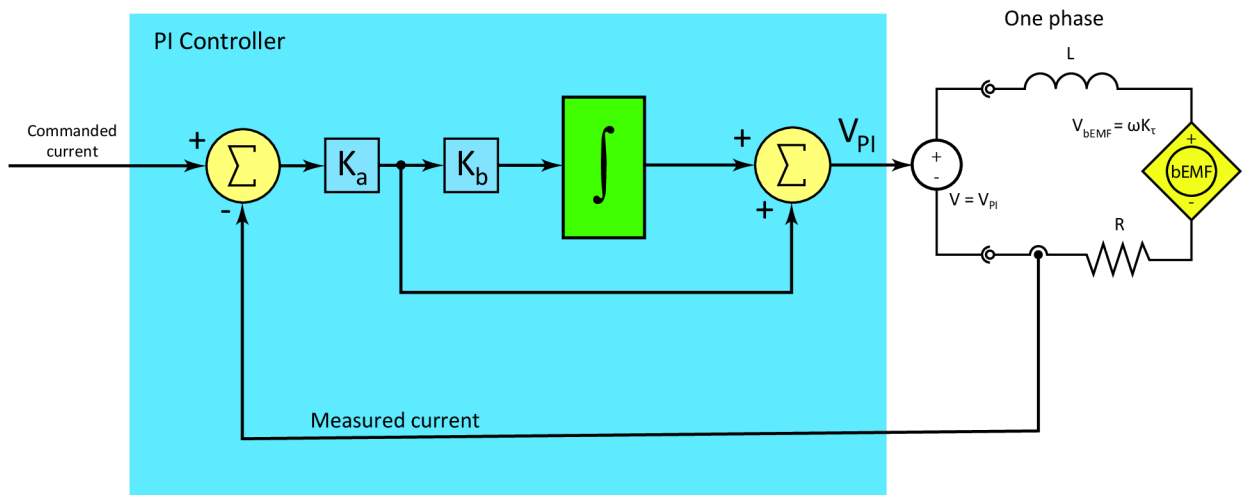

Figure 50: Current loop

In the system shown in Figure 50, the coefficient  $K_a$  determines the bandwidth of the control system. When the coefficient  $K_b$  is set to  $1/\text{winding\_time\_constant}$  (equation 22), the imaginary poles are canceled and the system becomes a first-order system. This is the way how peaks in the

frequency response can be avoided.

$$K_a = L \cdot \text{current\_bandwidth}[\text{rad/s}] \quad (21)$$

$$K_b = \frac{R}{L} \quad (22)$$

The integrator is used to eliminate steady-state errors. However, during its saturation, it can get into a problematic state where it creates a negative error value at the output. This effect can be prevented by limiting the lower and upper bounds of the integrator. These values should match the saturation values of the controlled system. However, sometimes the P member itself can bring control to saturation. It is therefore recommended to think about this when choosing the boundaries for the integrator, and thus implement dynamic bounds [18].

If it is necessary to create a control loop for the position, but it is not implemented in the cascade manner mentioned above, then it is appropriate to control the system with PID control structure, instead of PI control. The PI loop itself without a derivative term contains many integrating members in this case, and would create an oscillator. The derivative element corrects the phase lead and this improves the controller's function. Implementing a derivative element in a digital system tends to generate noise and is not suitable for that. The gain on the derivative term determines the sensitivity to a change in position - that is, a change in velocity.

Whole control system implementing FOC is shown in Figure 51.

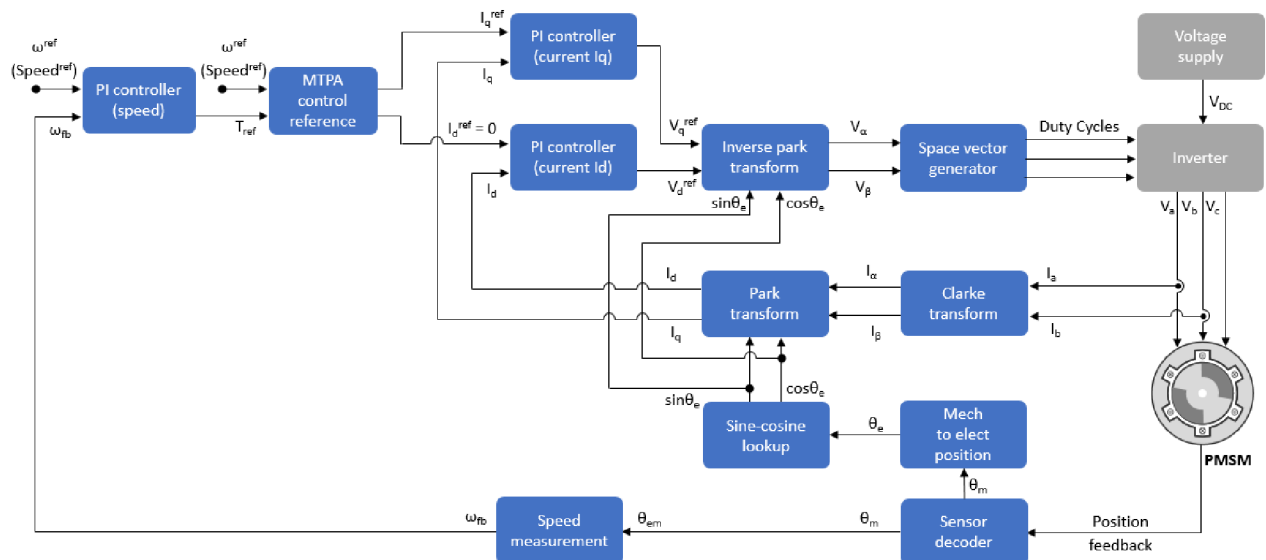

Figure 51: Complete control diagram for FOC<sup>1</sup>

<sup>1</sup>Source: Mathworks - implement motor speed control by using FOC

## Field strengthening/weakening

In the section 2.2 - Creation of torque in a motor, it was explained that the motor speed depends on the amount of current in the phases and that current depends on the total voltage on the phases. As the speed in motor rises, back-EMF rises, which acts against the power source, which decreases effective voltage on the phase terminals and current decreases, and increase in speed is not possible. This problem can be solved partly by driving the current not purely on the Q axis, but partly on the opposite D axis direction as well. Because the current is present on the D axis, it acts against the magnetic field of the permanent magnets, and they produce less back-EMF, which increases the effective phase voltage and thus the flowing current can increase the motor speed. Disadvantage is that the weakened magnetic poles of the permanent magnets cannot create original amount of torque, so there is a tradeoff between speed and torque. This is also true for the opposite effect. If current is driven in the direction of D axis, torque increases, but the maximum speed decreases. This increasing torque is of course not that efficient as the one created by driving the current only on the Q axis [18]. Both of these methods require demand for more current.

## Classes of neodymium magnets

Motor's torque constant contains a magnetic field density quantity. This quantity is the measure of field strength produced by permanent magnets in the rotor. Neodymium magnets are used in BPMS, because they have a very good size-to-field-density ratio. If the field density of these permanent magnets is high, with the same amount of stator current, it is possible to achieve higher magnitude of torque, than if weaker magnets were used. The class of neodymium magnets determines the field density. In table 1, the field strength is determined by remanence, which is the residual magnetization (more in Appendix A).

Grade	Remanence [T]		Coercivity [kA/m]	Intrinsic coercivity	Max. Energy product [KJ/m <sup>3</sup> ]
	Min.	Max.			
N30	1.09	1.17	≥796	≥955	255
N33	1.14	1.22	≥836	≥955	279
N35	1.18	1.25	≥859	≥955	294
N38	1.23	1.30	≥859	≥955	318
N40	1.26	1.32	≥836	≥955	334
N42	1.30	1.35	≥836	≥955	350
N45	1.32	1.38	≥836	≥875	366
N48	1.37	1.43	≥836	≥875	390
N50	1.40	1.46	≥836	≥875	406
N52	1.43	1.48	≥836	≥960	422
N54	1.47	1.50	≥836	≥875	438

Table 1: Quality of neodymium permanent magnets

## 3 Electric motor controllers

In the previous chapter, methods of electric motor modeling was shown. Also, two main methods of motor control were introduced. In this chapter, a safety aspect of electric vehicles is discussed and then the field of switching control is introduced, which is an implementation of one subsystem discussed in previous chapter. Information in this chapter is presented to state what influences controller efficiency and modern GaN switchers are introduced. If the reader would like to replace transistors in their motor controller to allow for more current or efficiency, or they may want to understand the efficiency standpoint of controllers, this section will make it clearer. It provides a minimal foundation for a designer who would like to implement their own controller. This chapter is not intended as a comprehensive overview.

### 3.1 Safety

Motor is the primary source of momentum in the vehicle, which is driven by a human. Motor safety and motor controller safety are therefore a priority.

Here are the main safety points that a car, or a scooter needs to handle in terms of driving and braking:

When the vehicle is started, the controller shall not start the motor without a deliberate command to accelerate

The change in driving direction can be done electrically or mechanically. When the change is done electrically, drive in reverse can be accomplished by stopping and moving in the opposite direction, or by a system that allows reverse drive only in case when the vehicle goes to the front slower than 1m/s. In the latter case, reverse drive activation shall be indicated obviously

Emergency system disconnection - It is recommended to consider an implementation of emergency button that disables the power delivery to the motor. Use of the emergency button shall damage the control electronics [3].

Unintentional acceleration caused by a problem in traction controller (that is supposed to prevent wheel slip) must be avoided, by using a safety controller for power control. Any possible failure shall not make the vehicle travel further than 0.1m from its original point(for still vehicle with brakes released)

Unwanted electric currents in the controller can cause a switch of high current to the motor. Traction and auxiliary circuits must be galvanically (electrically) isolated [3]. Electronics that makes up a controller must be protected against water condensation

Electromagnetic interference generated externally, or by the controller itself shall not negatively

affect controller operation [3]. The controller must be designed in conjunction with the rest of the vehicle, such that no radiating EMI is generated

For regenerative braking, the following points are to be considered:

1. Regenerative braking works on one axle only. Another means of braking must be available.
2. Regenerative braking does not work at very low speed or when the vehicle is stationary.
3. In many cases, the rate of deceleration for regenerative braking is limited and is not be sufficient for emergency stop.
4. On slippery surfaces, high levels of regenerative braking may cause loss of adhesion.
5. Torque inversions add wear and tear to the mechanical drive system.
6. When battery is full, effect of regenerative braking may be reduced, or the battery can be overcharged.

A friction-based braking must be available on the vehicle, that can stop the vehicle at any circumstances. To ensure safe operation and braking efficiency of the braking system, the braking torque should be applied gradually. Coasting must also remain possible. This last feature is especially important for achieving electrically efficient driving [3].

Though the scooter itself can be made relatively safe, the ultimate impact on the environment is in the human factor. Article [6] shows that drivers using the scooter while having alcohol content in their body pose a threat. The scooter are many times parked in inappropriate places [6], which is another problem of human factor. These factors must be borne in mind, because they are posing problems to cities, environment and society. And they cannot be affected by a good hardware design. Electric vehicle can be designed well from the safety side, but human use factor is dominant in the end.

Figure 52 shows a result of research organized through EVERS SAFE project as a part of Electromobility+ program [4]. The goal of research was to find out, what safety concerns arise when driving a vehicle with electric propulsion. It is recommended that the motor controller minimizes safety risks, including risks in Figure 52.

## 3.2 Electronics

When designing a control circuitry for electric motor, it is important to have its efficiency in mind. In this section, the issue of motor control efficiency is presented and then the ways in which these problems are addressed are presented.

Figure 53 shows the block diagram of a standard switching unit. This entire system is an im-

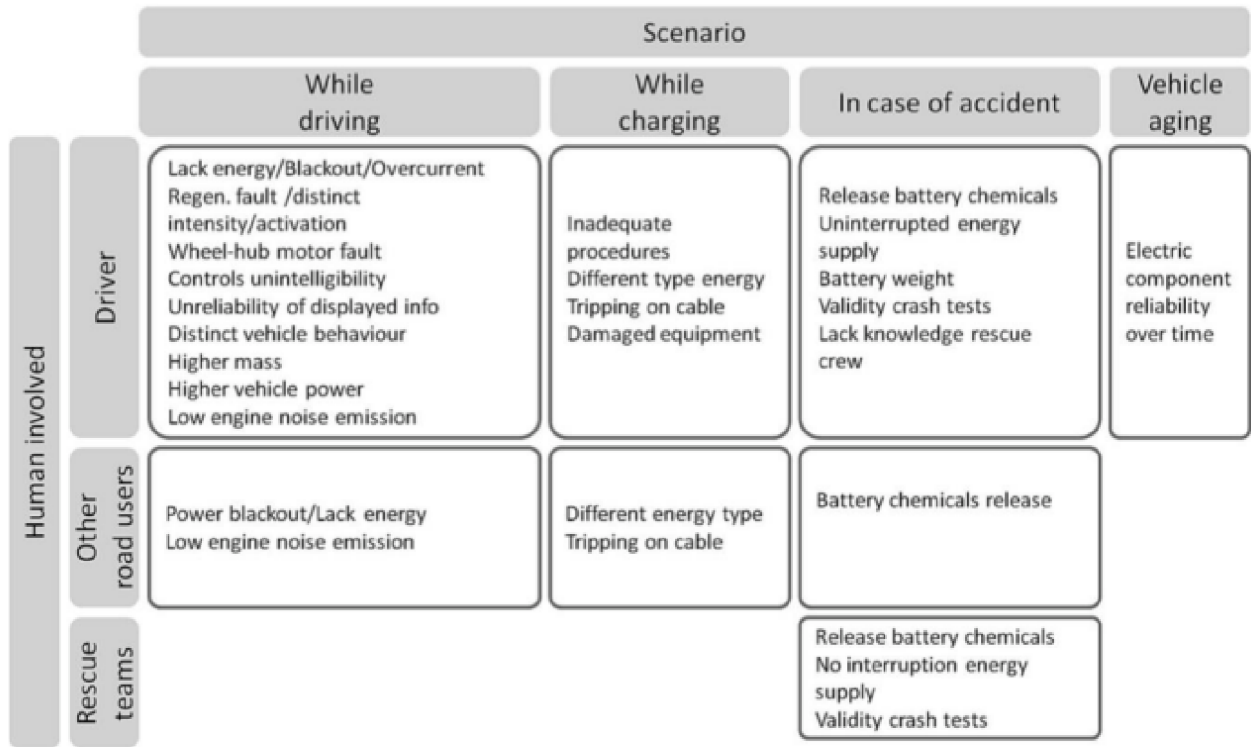

Figure 52: Taxonomy of user concerns regarding electric vehicles

plementation of a part of the control system from the 2.3 section. The controller commands the current value for all the phases. It does this with a binary signal controlled in time. This signal often cannot be delivered directly to the switches, mainly due to precise time synchronization or the capacitive and inductive requirements of the switches, which are manifested mainly by rapid switching changes. The gate driver solves this part of the problem and sends a synchronized signal directly to the upper and lower switching transistor at the same time. This is true if one gate driver is used to control two transistors for switching voltage to each phase. It would also be the case for the configuration in Figure 32 from previous chapter. Switches are power elements that change the voltage on the phases and deliver high currents through them into the phases. The motor itself then delivers the required power in the form of torque.

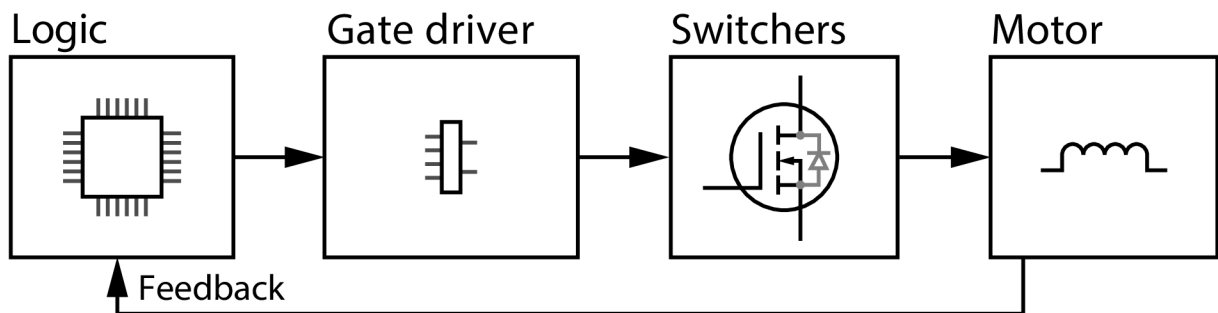

Figure 53: Block diagram of a controller



## Losses in the motor controller

Each of these blocks generates losses. The principle of motor losses is described in the section 2. In terms of the total power consumption in the controller, the voltage control block and the switching block are important, where the voltage control block converts the voltage from the battery to the voltage that supplies the electronics in the controller. Logic block losses can be minimized, for example, by putting the chip to sleep mode and turning off unnecessary circuits. The voltage control block operates with an order of magnitude lower power than the switching block. Thus, any change in efficiency on the switching block will have a dominant effect on the efficiency of the entire controller with its remaining electronics. This section will therefore focus only on the efficiency in the switching block and the efficiency of the other blocks may be neglected.

The job of switching block is to deliver power into the electric motor. This is achieved by using switching elements, mainly MOSFETs. These switching elements have their operation cycle that generates losses. This text is focused on the matured technology of silicon transistors and relatively new technology of GaN/eGaN transistors.

- Conduction losses

The ideal transistor has zero resistance when switched on. It does not matter what current flows through it, as long as it has between the source and drain zero potential, it does not generate with any losses. Different MOSFET products have due to their construction various conduction resistance ( $R_{DS(on)}$ ). This resistance increases with the temperature of the transistor. The greater the resistance, the less current flows through it at the same voltage [7], but the power product increases according to  $P = R \cdot I^2$ , up to the point where this resistance limits the current more and thus the loss is reduced to an equilibrium point (combination with the formula  $I = U / R$ ). The primary job of a MOSFET is to conduct current during its on phase. Thus, the lower the conduction resistance and the less often it is conducting, the less losses it generates.

- Switching losses (turn-on, turn-off)

MOSFET's job is to change its resistance between the source and the drain, depending on the charge on the gate. In an ideal state, MOSFET transitions from the state of full desaturation of the gate to the state of full saturation of the gate, and it changes its resistance from infinitely large to none in an instant. In real MOSFETs, the resistance changes from a non-conductive value (which can be overcome by opposing breakdown voltage on the transistor) to a value in conductive state and this change takes some time. Switching to non-conductive state is faster than to conductive state. Every switch cycle is at a cost of switching loss, which generates heat.

- Losses during the reverse recovery of the MOSFET body diode

Also called dead-time losses, or reverse leakage current. The MOSFET is structurally constructed such that N channel MOSFET contains a body diode from the source to the drain and the P-channel contains it from the drain to the source. This diode is defined by two parameters. Conduction voltage drop and charge  $Q_{rr}$  (reverse recovery). Both parameters cause losses. The latter type of loss is present in the so-called low-side transistor, which connects the inductor to the common zero point. When a current flows through the transistor in the direction of the body diode and the voltage changes so that this current stops, free electrons are present at the PN junction. They change their polarity against the voltage of the transistor (standard working polarity of the MOSFET in the off state) and flow against the direction of the diode. These electrons flow through the PN junction until they fully restore the diode's barrier and the diode recovers. Then the reverse current no longer flows. The lower the charge of this diode, the faster the diode recovers and the amount of electromagnetic interference generated by the transistor during that phenomenon is reduced.  $Q_{rr}$  increases with higher temperature, higher switching current, faster switching, higher transistor operating voltage and longer dead time.

- Losses during freewheeling current

By default, a MOSFET connects in reverse to its body diode, but when the high-side MOSFET is turned off, the current driven by the coil flows through this diode in the low-side MOSFET (case 2 and 3 in fig. 33). During the flow of this current, a voltage diode up to the value of  $V_{SD}$  (source-to-drain) is present in the diode and that with a current flow, this generates losses. These losses are constant regardless of current, so the more current flows through the transistor, the lower significance this loss has.

- Capacitance losses ( $C_{oss}$ ) Since a switching element no matter if GaN FET or SI FET, has a gate separated by a layer of oxide, transistor has these capacitance values:

Input capacitance  $C_{iss} = C_{GD} + C_{GS}$

Output capacitance  $C_{oss} = C_{GD} + C_{DS}$

Reverse transfer capacitance  $C_{rss} = C_{GD}$  [13]

The gate driver must charge the MOSFET gate. The larger the capacitance of the gate, the more energy is needed to charge it and it also takes longer. This type of loss is the price for each state change (on / off) of the transistor. So the higher the switching frequency, the higher this loss is per unit time. Larger MOSFETs tend to have lower resistance between the source and drain of the transistor in conduction state. As a result, they have lower conduction losses, but at the expense of larger gate capacity.  $C_{oss}$  is a nonlinear capacity of the switching element and is directly proportional to the voltage  $V_{DS}$ . When hard switch is performed, the charge from the supply is transferred to the channel and it ( $C_{oss}$ ) gets charged. Thus, transistor generates loss with every switching cycle.

$C_{oss}$  has a dominant share on capacitance losses and it is a function of the voltage between the source and drain ( $V_{DS}$ ). For each cycle,  $C_{oss}$  loss =  $V_{bus} \times Q_{oss}$ .

- Problems with Miller capacitance, or common-source-inductance At high switching speeds of GaN (in gigahertz), the common-source-inductance effect begins to appear. This effect can create oscillations and reduce the switching speed. Any induction, even parasitic induction of the resistor used for current measurement placed before the source of the transistor, at fast switching on and high currents will cause a voltage to rise on the resistor, because of its inductive property that becomes apparent. This will change the voltage between the gate and the source of the transistor, because the gate is referenced to ground (GND), and thus an oscillation arises between the capacitance of the gate and the induction of the source of the transistor. For SI transistors, the Miller capacitance has a similar effect, but in a relationship with transistor's drain.

The reader can find more information in [8] and [10]. These losses have a direct impact on the design of software that controls the switching elements. If the reader does not understand the impact of non-ideal control of the switching elements on their efficiency, they may make unwanted design errors in programming, which leads to lower efficiency during the use of the device.

Figures 54 and 55 show different sources of losses relative to each other on high and low-side switch. Switching losses dominate in high-side transistor and conduction losses dominate in low-side transistor at higher switching frequency.

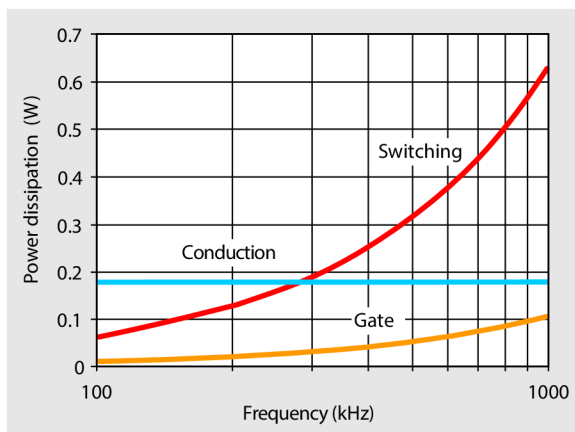

Figure 54: High-Side MOSFET losses

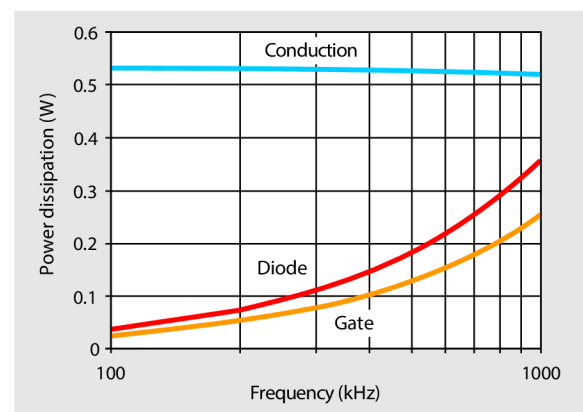

Figure 55: Low-Side MOSFET losses

Options for minimizing individual losses will now be presented. When all the following procedures are considered, switching efficiencies of up to 99.3% can be achieved.

### Decreasing conduction losses

To reduce the conduction losses, it is necessary to select a switching element with a low value of  $R_{DS(on)}$ . Silicon MOSFETs generally have a lower conduction resistance than eGaNs (enhancement-mode Gallium Nitride Field-Effect Transistors). These losses can also be reduced by reducing the conduction time. This is often ensured by faster switching and it is necessary to look at other emerging switching losses when increasing switching frequency.

### Decreasing switching losses

When switching occurs, transition between conduction and non-conduction phase results in gradually changing resistance. This resistance is responsible for switching losses. These losses can be reduced in two ways.

The first way is to implement Zero-Voltage Switching (or soft-switching). With this method, it is necessary to ensure that there is no voltage between the source and drain of the transistor during the transition of the resistance from the non-conductive to the conductive state (and vice versa). Thus, no current will flow through the transistor during the transition and current will not flow until the resistance has stabilized at  $R_{DS(on)}$ .

Switching losses can also be reduced by using a GaN switching transistor, which has a faster switching curve than that of a silicon transistor.

When a DC-DC rectifier uses a low-side transistor, it is called a synchronous rectifier. With such a rectifier, but also with low-side transistor phase control, it is possible to operate the transistor in soft-switching [33](#) mode. When both the high-side and low-side transistors are switched off (dead-time state), the coil begins to push the current through the body diode of the low-side transistor and losses begin to occur due to the voltage on the diode. This process also reduces the voltage across the transistor, and when the voltage reaches point  $V_{DS}$ , which is the diode voltage, the transistor can be turned on in soft mode. If the transistor were left closed after reaching voltage  $V_{DS}$ , there would be unnecessary further losses on the diode.

### Decreasing reverse-recovery losses

This type of loss can be reduced by using a transistor with low  $Q_{rr}$  charge. GaN transistors do not have this value and reverse recovery effect is not relevant to them, because their junction structure is different from that in silicon transistors.

### Decreasing diode forward losses

GaN transistors have a conduction voltage greater than that of silicon transistors. This causes an increase in voltage across the transistor during the current flow and there is a heat loss [11] associated with it. This also prolongs the dead-time of the transistor, which further adds to losses. Thus, if this diode characteristics is used frequently, it is suitable to use a switching element with a low value of  $V_{DS}$ , i.e. to use a silicon transistor. The value of  $V_{DS}$  in GaN is directly proportional to the junction temperature and in SI it is inversely proportional (so the warmer the transistor is, the lower the diode voltage) [25]. This loss is also directly proportional to the current flowing through the diode when both high and low-side transistor is off. To minimize the losses, the dead-time should be kept to minimum. If these losses cannot be limited by using software or hardware control with adaptive dead-time adjustment, a Schottky diode can be added in parallel to the low-side MOSFET, reducing the loss during longer dead-time. This applies to eGaN. For SI, a workable solution is to monolithically integrate this diode into the MOSFET substrate, otherwise the addition of another diode has no effect [10]. To properly install a Schottky diode for an eGaN transistor, it is necessary to place the diode on the printed circuit board near the transistor and minimize the impedance of the diode package. Also, the diode should be connected to minimize traces loop inductance between the diode and the LGA case of the eGaN transistor.

### Decreasing capacitance losses

Losses associated with the gate capacity can be reduced at a lower switching speed by using a switching element with a lower  $C_{oss}$  value. At higher speeds, the capacitance at the output of the transistor ( $C_{oss}$ ), together with the parasitic inductance of the transistor creates an LC oscillating circuit, which contributes to losses as well as to interference radiation during switching. This parasitic inductance can be suppressed by utilizing a good PCB design, where the H-bridge return current is directed one layer below the H-bridge [11]. Thus, the size of forward and return switching currents for charging  $Q_{oss}$  are the same and in the opposite direction from each other. This cancels the induction in the power loop and increases the energy in the resonant ringing. This conductive loop should be as narrow and flat as possible. In combination with a properly sized resistor on the gate, it is possible to ensure a relatively clean switching cycle. This applies to switches in DC-DC converters with currents around 10A. For a motor switching circuits, the design needs to be modified to handle the high currents that flow through the motor coils. It is also recommended to choose small capacitors with low package inductance placed close to GaN transistors, if this technology is used. These capacitors provide an initial current to charge  $Q_{oss}$ , and since switching is very fast and the current source is very close to the GaN transistor, the effects of induction when charging  $Q_{oss}$  are minimized. By placing a resistor between the transistor gate and the gate driver, capacitance loss will reduce at the expense

of increased switching time [25].

Another effect of  $C_{oss}$  capacitance is the current distortion due to the extended turn-off phase [13].

### **Decreasing common-source-inductance**

This phenomenon can be limited by utilizing good PCB design, or by using a gate driver that contains a return pin for the low-side FET. CSI can also be limited directly by modifying the semiconductor structure of the transistor. For the designer, this means choosing the right product [26] [25].

### **Soft switching**

Soft switching is a method, where no current flows through the transistor during the state change (from non-conductive to conductive and vice versa). This eliminates switching losses caused by a gradual change in resistance in the transistor. Soft switching can be achieved in several ways.

Zero-Voltage Switching is a technique, in which the transistor is switched on just when the potential between the source and drain of the transistor is zero. This reduces or eliminates the switching loss. If an electric potential were present on the transistor during switch-on phase (which is a common situation), a current according to ohm's law would begin to pass through the transistor and thermal loss would be generated in the transistor. This method does not work during transistor switch-off, and another method, such as zero-current switching, must be used to achieve a soft switch-off. Ideally, the switch-on should occur during zero voltage between the source and drain, and the switch-off should occur during zero current between the source and drain, but the latter case is too difficult to design and usually it is not worth to implement zero-current switching [12]. ZVS presents a problem, where if the recombination process of the body diode is not completed before the end of the conduction period, accidents and destruction of the MOSFET can occur.

A resonant circuit can be used to implement Soft-Switching. The topology used by this circuit is called the Auxiliary Resonant Commutated Field (ARCP) and is discussed in the literature [23]. Implementing these techniques for motor control can increase the system efficiency, but if the motor control uses wide range of modulation frequencies, design of an efficient system can be very difficult.

### **Gate drivers**

Controlling the field effect transistors at high speeds or specific applications is not trivial. Therefore, part of the switching issues is addressed in a separate block. This is the gate control block that drives one or more switching transistors. Below is a list of points that gate driver addresses:

- Input charge
- Demands for gate drive
- Switching time
- Gate losses
- Transformer isolation
- DC Restorer
- High and Low side switches
- Ground an voltage source (bootstrap)
- Gate ringing
- Voltage overshoot
- Electromagnetic interference

These points are mentioned for coherence but will not be addressed further.

Designing a driver that meets safety, efficiency and stability requirements is challenging. An analysis is required to select the GaN / eGaN technology over the MOSFET, where impact of individual loss parameters on the controller are compared. Parallelization of switching elements for higher switching currents presents other problems, such as [9]. Technology, however allows to create a final driver design with very good working efficiency.

### **3.3 Commercial controllers**

The issues described in above texts are to some extent solved in commercial solutions, but are still under development. Commercial products are often optimized for general use, which means that for a wide range of applications, their solution is "quite good". Three distinct motor control solutions are listed. The internal construction of these products - specifically software and hardware is subject to company secrecy, therefore the description of these controllers contains only the parameters that are beneficial for the user who wants to choose between the available solutions.

It must be borne in mind that different motor controller solutions are integrated in different ways. The three product described are for general motor control application in personal electric vehicles. But there are also motor controllers, as in M365 scooters, which contain additional software management and features of the product, so the motor controller is integrated in the management unit of the product.

## Phaserunner

Phaserunner is a very popular solution from Grin Technologies for controlling various types of motors in scooters, electric bicycles and other personal electric vehicles. It is a family of drivers that has versions of the product. The first is the BAC500+ from the year 2013, the V1 from 2016, the V2 from 2017 and the V3 from 2020. Grin Technologies does not publicly provide construction details or specific solutions used in its Phaserunner family of products. However, it can be expected that it contains a microprocessor connected to the UART port for configuration, a controller for power transistors, sensors (hall for positioning the motor (external), a current shunt resistor, etc.) and it is of course connected to the power supply through a DC-DC converter.

This controller can control motors with and without HALL sensors. The so-called sensorless mode is usually implemented by detecting the back-EMF on the coils in the motor. This detection is done either by measuring the voltage on the coils during the period when the switching elements on the measured phase are switched off (so-called dead-time), or by approximation using other measurements [17]. The Phaserunner also allows the user to use the field weakening technique, which makes it possible to achieve a higher maximum speed.

The product itself is designed to control a wide range of motors in electric bicycles. It achieves this mainly due to the possibility of software configuration. It also supports field oriented control, which allows for more efficient motor control with less torque ripple. It is rated for motors from 500W-2000W.

MCU allows to configure (program) the following parameters:

- Type of motor - sensored or sensorless, type of winding, coils induction, ..
- Strength of regenerative braking
- Battery operating range for regenerative braking
- Battery current limits
- Maximum phase, recovery and field weakening current
- Sensorless starting parameters
- Voltage of the throttle and its mapping to resulting acceleration

Phaserunner also supports Cycle Analyst, which can be connected to the phaserunner and it allows to use the phaserunner in more configurable way. The user connects various peripherals to the Cycle Analyst such as the accelerator pedal, thermal sensor for the motor, brake and more. The



Type	Maximum values (25°C)			$R_{DS(ON)}$	Turn on time	Turn off time	Technology
	Voltage	I	Thermal power				
AOT290	100V	140A	500W	2.5mΩ	24ns	27ns	Silicon

Table 2: Parameters of switching transistor inside Phaserunner



Figure 56: Phaserunner v3 motor controller

Cycle Analyst then instructs the Phaserunner on how to control the [14] motor.

After connecting the motor to the controller, the controller must be configured via the software in the computer through the UART port so that the controller works correctly with the connected motor type.

The price of one controller is around 340€<sup>1</sup>

## GAN Runner

In the previous section a GaN switch was introduced. This type of transistor has some unique advantages. Ftex company is trying to utilize this type of transistor in their GANRunner product. In this report it is shown as an example of emerging technology of motor control using gallium nitride technology. The company claims that their solution can increase the range by up to 15% [15]. It is well known that the primary advantage of gallium nitride transistors over silicon transistors is their higher maximum switching frequency. These transistors have also higher power density. But the goal of Ftex not to create a smaller product thanks to smaller elements operating at a higher frequency (i.e. to increase energy density). Their goal is to work with energy control more efficiently [16]. It should be noted that especially startup companies tend to present their solution in too positive way, which attracts the interest of investors. Regardless of this example, gallium nitride technology certainly has a place in the field of electric motor control and is a subject of active development.

Price of one unit is \$450<sup>2</sup>. They will be able to control two motors simultaneously.

<sup>1</sup>On fasterbikes.eu store, as of May 2022

<sup>2</sup><https://www.facebook.com/commerce/products/4473781315980098>, May 2022



Figure 57: Ganrunner controller example

## Flipsky ESC

This series of controllers is unique. It comes from the VESC project (various electronics speed controller) by Benjamin Vedder, which is an open-source system for controlling electric motors. Open-source firmware and hardware can be found at <https://github.com/vedderb>. VESC supports Controller Area Network (CAN), which is a bus protocol based on multi-master and broadcast architecture. The physical layer of the protocol is specified in ISO 11898 and the data layer is maintained by the organization at [can-cia.org](http://can-cia.org). These specifications are for purchase. More information can be found in [24]. This driver is based on the STM32F4 microprocessor, and its firmware is implemented under ChibiOS. Part of this bundle is a configuration tool for windows, Linux and OS X. This driver has the following features:

- Sensored and sensorless control
- Regenerative braking
- Field weakening
- Multiprotocol bus for motor control
- Measurement of expended and recovered energy in amp-hours
- Over 40 different configurable parameters available through PC software

Flipsky sell slightly modified controllers based on VESC. The modification includes different capacitor and transistor values and layout, and some minor tweaks. Firmware used is the same as with VESC. Available are controllers for single (fig. 58) or for two motors (fig. 59). They also provide two power variants whose two main parameters are maximum peak current and maximum sustained current.

Price of the unit in Figure 58 is \$96 and that in 59 is \$315.<sup>1</sup>

---

<sup>1</sup><https://flipsky.net/collections/electronic-products>, May 2022



Figure 58: Flipsky Mini FSESC6.7 70A



Figure 59: Flipsky Dual FSESC6.6 6.7 Plus

## 4 Current state of M365 scooter

This chapter shows the available dual-motor electric scooters and the Xiaomi electric scooter in its plain form. Conclusions are made on what these products lack and how these missing features can be solved.

### 4.1 Electric scooters with two motors

Market provides ready-made solutions for dual-motor electric scooters. Scooters with two motors are not intended for regular way of transportation, but they are made for long-range and high-speed driving. Dual motor scooters are *Apollo Pro 52V*, *Unagi Model One*, *Widewheel Pro*, *Speedway 5* and a couple of other. Price of these scooters varies from about 990€ Up to 6000€ on european market.



Figure 60: Dual motor electric scooter<sup>1</sup>

Figure 60 shows an example of dual-motor electric scooter Dualtron X. This type of scooter belongs to the top tier category from this manufacturer. In Figure 61 a block diagram of electrical components for Dualtron Thunderer is shown.

It was not possible to find block diagrams for other brands of scooters, but from several sources where these scooters are taken apart, it is possible to state that they use two controller units each for one motor. Varla Eagle also uses this configuration. These controller units are either standalone

---

<sup>1</sup>Source: reference [2]

## Electric wiring diagram

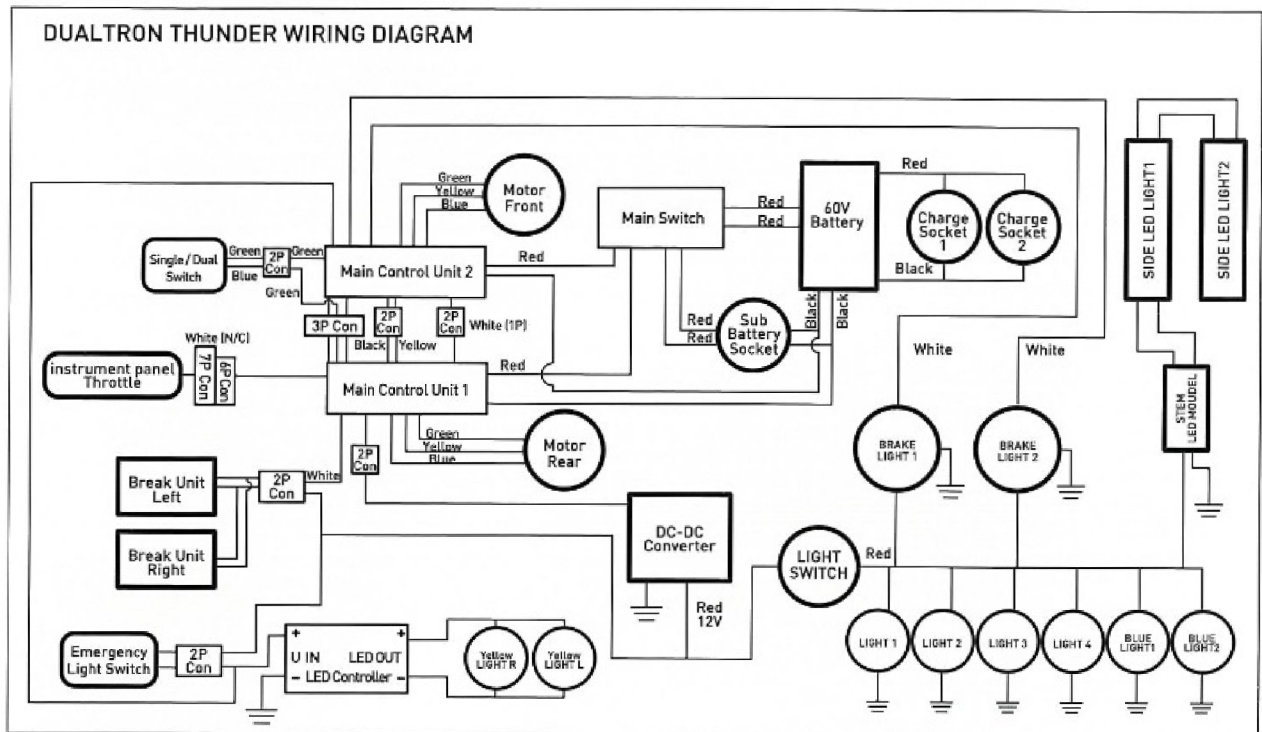

Figure 61: Electric diagram of Dualtron Thunderer<sup>2</sup>

products or modules and they are either interconnected between each other, or they are connected to a central controller unit.

This solution poses an advantage for the consumer such as easy replacement of damaged unit in case of failure. Advantage for the manufacturer is, that they do not need to design whole electrical system for the scooter, but they can design distinct units with their own specifications, and then they can interconnect them together in a final product. If one drive circuit fails, if each circuit contains its own controller, the scooter can be still driven with one motor, which is also an advantage. If the scooter used two motors with the sae controller, if the controller gets damaged, both motors are out of order.

All manufacturers of commercially available scooters use the same front and back electric motors with the same power output and driving characteristics. That reflects in simpler design and service. There may be a slight problem that when the motor is attached directly through the bar to the handle, driver must turn a bigger mass than turning a non-motor wheel. On the other hand, weight of the scooter is more distributed and thanks to the increased weight, better traction is achieved.

<sup>0</sup>Source: reference [1]

## 4.2 M365 Pro 2

M365 Pro2 Xiaomi is manufactured for maximum output power of 600W and an average power of 300W. This power is delivered using a single motor which is integrated in the front wheel. Back wheel is mounted onto the frame using bolts from both sides and it contains a braking disk. Braking plates are mounted on the scooter's frame and on command, these platters as well as regenerative braking decelerate the scooter. Driving information is available on a bright display. This display is visible during sunlight.

The manufacturer refuses to publish any specific documents covering the production process or any design details. But some of the parameters can be concluded from product analysis. Therefore, the information provided here is a result of the analysis, rather than from official documents.



Figure 62: M365 frame

The frame is manufactured using parts of rolled, cast, or milled aerospace grade aluminum [27]. Some parts are welded on top of each other. Aluminum offers a good balance between weight, frame strength and price. During body design, such methods are used, that reduce the amount of required material for the frame. The material that remains should not subceed 150% of designed structural integrity [5]. By reduction of used material, manufacturing price decreases and the scooter is lighter.

User can command the scooter by two inputs. Acceleration throttle and brake. As was mentioned, brake mechanically stops the scooter and instructs the controller to use regenerative braking. Acceleration throttle commands desired speed. Front button is used to wake the scooter up, to change driving modes which are built into the system and to turn the front light on and off. Part of the scooter bundle is a phone application. Scooter pairs to the application and user can see additional parameters, such as firmware version, regenerative breaking parameters and cruise control. User needs to “activate” the scooter after purchase, otherwise its maximum speed is limited to 15km/h.

Display shows the front light status, driving mode, speed, possible error code, and the battery charge is presented in 11 discrete states shown on 5 segments. Speed is calculated from motor RPM and wheel radius.

### **4.3 Problems with the M365 pro 2 scooter**

After long term use and analysis of the scooter I found the following problems.

General hardware problems:

1. Front handle screws get loose
2. Battery percentage is desired instead of bars
3. Scooter cannot drive on higher elevations, or drives them inefficiently
4. Scooter's maximum speed is too low
5. Motor appears to be driven inefficiently due to subtle noise.
6. Driving experience is not as desired
7. Display brightness is not adjustable (problem during night)

Now a brief solution description is provided for the problems above:

Screws must be replaced by another mechanism that will secure the handle to the frame. I propose using tightening bolts. This requires hardware modification and will not be addressed. Adjustable display brightness and battery percentage can be achieved by custom module design. This problem will not be addressed in this report as well. Problem 3 can be addressed by adding secondary motor to the scooter. Problems 4, 5 and 6 can be solved by modifying the motor control system. Addressing these problems is the focus of this thesis.

So, the following is necessary:

1. Implement a secondary motor in the scooter
2. Implement a control system for the two motors

## 5 Options for scooter upgrades

In the previous text, the state of electric scooters was introduced and problems in M365 pro 2 were identified. The result is a series of problems and here I propose the possible solutions. To solve the problem number one, an additional motor must be bought and mounted onto the scooter frame. In chapter 2, it has been shown that there are many types of electric motors. That's why, firstly, an analysis of the currently present motor must be performed and then, either two new motors need to be bought, or just one additional motor needs to be bought and mounted onto the frame.

By solving problem one a good quality motor has been found. Now, there comes a need to control this motor. Since two motors will be used, they need to be controlled simultaneously. Since the report focuses on efficiency, most efficient options are desired. Sections 2.3 and 3.2 describe how to achieve the switching control and how to implement a switching circuit that has as few losses as possible. But designing a custom motor controller is over the scope of this report. Section 4.1 shows that dual-motor scooters use two controller units that are interconnected in some way, so this is also considered. Commercially available controller (chapter 3.3) offer the possibility to control trapezoidal and sinusoidal motor as well, and they are relatively efficient. maximum switching power mus also be accounted for.

Motor controller is able to do more than just the driving the motor. It implements software that may provide useful information for the user and some units have the possibility to change the driving experience.

Considering all these points, three options for controller upgrade are proposed:

### 5.1 Ideal option

If money are of no concern, implementing this solution may be better than buying already available dual-motor scooters, since this variant is highly configurable, which is its main advantage. This variant is composed of the following steps:

1. Buying a desired scooter for frame
2. Keep or buy motors with desired power
3. Possible frame modification to fit the desired motor
4. Buying additional battery packs and interconnecting them
5. Buying a high-quality BMS (battery management system) if necessary
6. Buying Dual F5ESC6.6 6.7 basted VESC6 with aluminum cooler
7. Interconnecting everything together and tweaking the software.



## 8. If desired, hooking up an external display and programming a HUD

It is impractical to build a scooter from scratch. Desired and visually appealing scooter is bought. It is used mainly for the construction features. If batteries or motor/s are insufficient, they can be replaced. BMS mostly use a standardized communication bus with busses such as RS485 (UART), CANBus, SMBUS protocols. Dual FSESC enables a feature rich option for driving and solves the problems 4, 5 and 6 mentioned in previous sections. If external display is desired, a module using TFT display, ESP32 and display software can be implemented as a module and connected to the FSESC. FSESC contains built in calculation of energy flow in the scooter, which can be displayed. Also maximum reachable speed at the current battery voltage could be calculated. Desired acceleration throttle and brake can be used and interfaced with FSESC. User has almost full control over the driving parameters, so they need to be configured and the upgraded scooter is ready. Since it is based on the open-source software and hardware, in case of failure, the user is able to diagnose and fix the problem with the motor controller. The only disadvantages are price and time invested into the upgrade. Otherwise, state of the art features can be achieved on the scooter. FSESC has been developed for a long time and has implemented many security features over time at the hardware and software level (against the effects described in 3.1) so the rider can feel safe when using this solution.

## 5.2 Low-cost option

The reader may want to have a dual-motor scooter at the lowest possible cost. This is achievable in an only way. Keeping the existing wheel and its controller in the scooter and buying an equivalent motor to the original one, buying secondary controller identical to the first one and interconnecting the two microcontrollers with the battery and a main synchronizing unit. This way, the same controller that drives the front will will drive the back wheel as well and this should simplify the design. It is technically possible. Synchronization unit is proposed to be implemented on an ESP32 because it has a lot of computing power and is well documented. ESP32 will have acceleration throttle and braking pedal attached to its analog to digital converter and will connect to both motor drivers, effectively replacing the front display module on the scooter.

Main disadvantage of this proposal is the need to find all the needed documentation either from online sources, or by self-performed reverse-engineered. This variant is composed of the following steps:

- Buying an electric motor identical to the original one

- Design and implementation of the frame changes to accommodate the back motor
- Design of the new block diagram for the electric scooter
- Solution of the problems concerning implementation of the block diagram

### **5.3 Perfectionistic option**

If the reader is not satisfied with proposed solutions, they solve the problems presented in chapters 3 and 2.3 themselves. This report offers broad introduction into the field of motor control for electric scooters, use of most modern GaN switching technology, layout of components on a PCB is briefly mentioned for minimizing EMI radiation, motor principles and motor modeling. This should allow for a foundation to design own controller, even a commercial one. But this report does not contain complete information for this design and should be used as a biref reference to check, if the designer has not forgotten something.

All of these options allow for increased power output of the scooter. Higher acceleration is expected as well as an ability to ride roads with higher inclination more efficiently. Control over driving parameters depends on the option implemented, but all option should present a way to attach customized display for drive information, which is not possible without modification.

## 6 Implementation of the scooter upgrades

In the previous section, problems in the scooter were shown and three solution options were proposed. In this section, variant 2 - low-cost variant will be implemented.

This is the block diagram of the whole solution. It contains an extra motor that needs to be chosen, this additional motor is controlled using a new chosen controller and the whole system is controlled by a custom designed microcontroller solution. The decision process that lead to this diagram is presented in the text below.

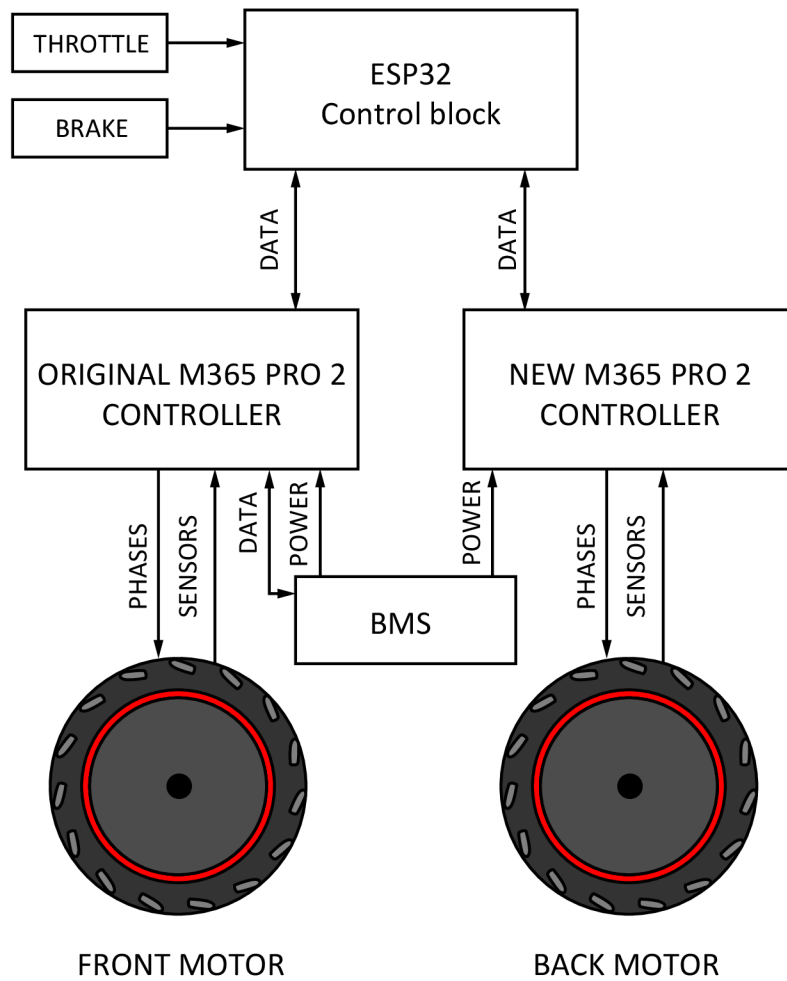

Figure 63: Proposed block diagram

### Motor in the M365 scooter

Before buying the motor, it was useful to find out which kind of motor is in the scooter and then to choose the most efficient one. The two main parameters have an impact on the efficiency of the electric motor in the scooter. The first one is method of control and the second one is the type of magnets used, which has an impact on the torque constant. The higher this constant, the more

efficient the motor is when driven correctly.

First step is to find out, whether the motor in the scooter is sinusoidal or trapezoidal, and the second step is to understand the principle of its control. The electric motor was opened and its geometrical model was created and implemented in a programmed WebGL application.

Motor contains 30 surface mount magnets, whose faces are magnetized. These magnets are inserted in an alternating polarity around the inner side of the rotor. Motor also contains 27 coils, which are distributed in the following way. 27 coils are divided into three phases, one phase having 9 coils. These 9 coils are split into 3 groups by 3 coils. These triplets are placed  $120^\circ$  from each other around the rotor (Figure 64).

Next, a six-step commutation mechanism was implemented into the simulator. As the rotor turns around the stator, always when particular hall sensor crosses magnet edges, a sector changes and the polarity of phases is changed. As the rotor rotates to the right, transition between one sector to the next is shown in Figure 65, which is a screenshot from the simulator. Now it is almost certain that the motor is commutated by six-sector method. To test this hypothesis back-EMF was measured on two terminals of the phases, but sinusoidal waveform was shown on the oscilloscope. So it must be geometrically optimized, which is a good. This brings the possibility of achieving very little torque ripple. When all three motor phases were shorted, very small ripple was felt by hand during slight motor movements. This motor might be suitable for FOC method.

About permanent magnets, finding any documentation for the motor was not possible. It is therefore not possible to know the specified torque constant and the only way to know the strength of the magnets is to measure them. But even if the strength of the magnets was known, and they would be weaker than the best available ones, it would not be economical to replace them, because magnets with precise dimensions would need to be bought and glued into the rotor's body, so that the air gap between the magnets and stator is as small as possible, but also big enough, that rotor would not crash into the magnets during small deviation.

A motor for M365 Pro 2 scooter was bought. With shipping, taxes and customs clearance process, the price per unit was 92€. Back-EMF waveforms were measured and they are identical.

### **Frame changes and motor mounting**

Fortunately, to test out the dual-motor scooter, no damage has to be done to the aluminum frame. The phase wires need to be bent a little to fit through the hole back in the scooter and pins of the hall sensors connector need to be removed to fit through the hole. Also the brake system needs to be removed as it just touches the motor body. Additionally, motor can be tightened to the frame by using original nuts. To make a good and permanent connection to the body, holes need to be milled

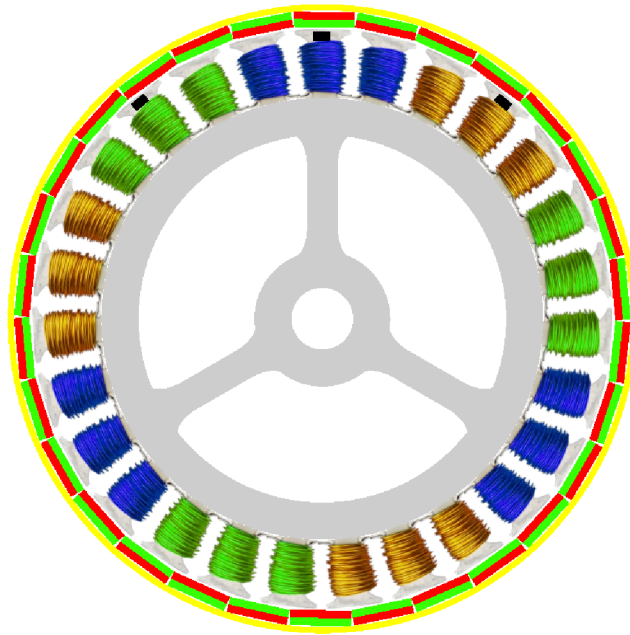

Figure 64: Visualization of the hub motor used in the scooter

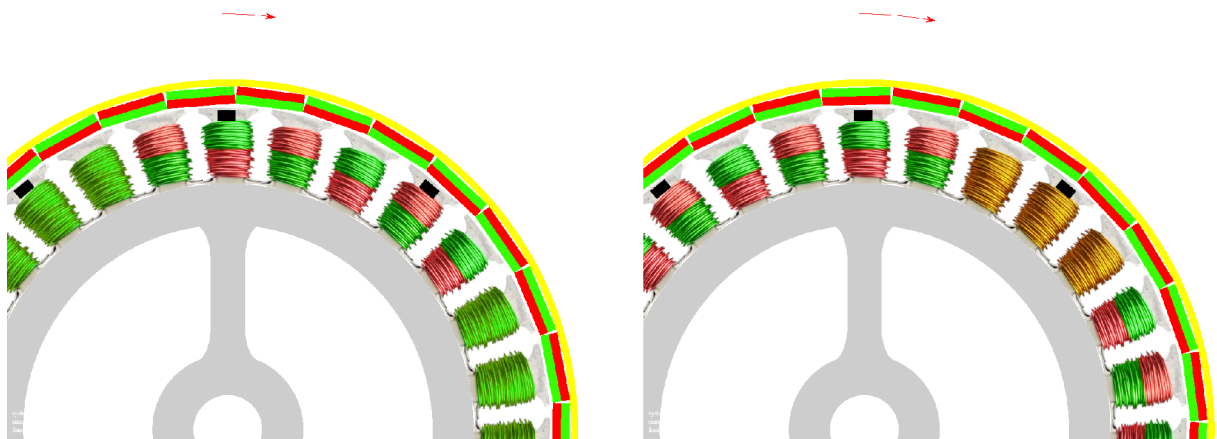

Figure 65: Simulation of the commutator in the scooter

into the aluminum frame and adapter needs to be made. This was not done and is left as the next step for the project completion.

### Design of the system

As both of the motors are mounted onto the scooter frame, the proposed diagram of control elements is shown in Figure [63](#).

Only one of the controllers will be talking to the BMS and the control block will be asking only the original controller for battery information. The two units are placed in the tight space under the board. The secondary controller cannot be fully fitted in with the big heat sink so this is another problem that remains unsolved. The control block will be sending commands to both of the units that will respond with the same algorithm and drive the motors simultaneously. This way a cheap way of synchronized control is achieved. The ESP32 control block will monitor speed from both

of the controllers at the same time and compensate for the error. Compensation should be very small to avoid oscillation. If the control block detects that one of the motors does not respond to the commanded value and the other motor does, error is present only on one motor and the control block should release the throttle command and notify the driver. After a while, system should recover.

### **Analysis of electronics in the scooter**

In order to make the diagram and to be sure that the proposed solution is usable, electrical system of the scooter had to be analyzed.

The electric scooter was disassembled and its block diagram was created and is shown in Figure 66. The whole system contains three main electronic components, which are:

Display together with a bluetooth module. In this report, this module will be called 'BLE'. Its type is nRF51822. This module performs three main functions. First one is pairing to a mobile phone and transferring data to and from it via bluetooth protocol. The second is displaying the drive information onto a LED display. Third and most important is the transmission of data to the motor controller and the retrieval of the response. The transmission data includes, among other information, the position of the accelerator pedal and the brake.

Motor control unit, called 'ESC', which uses the STM32F103CBT6 microprocessor. This processor communicates with the bluetooth module and the battery control unit. It sends a motor drive signals to the gate controllers of the transistors that control the switching the current to the motor. Thus, a motor control algorithm is implemented in this unit. There is also a DC-DC converter on the printed circuit board, which supplies the processor on this board as well as a bluetooth module with correct voltage.

Battery control unit, called 'BMS'. It takes care of the voltage balance on the battery cells and monitors operating cycles. It also monitors cells temperature and contains its own power supply. Charging circuitry is integrated on the printed circuit board of this unit.

### **Reverse engineering of the communication protocol**

A firmware file was downloaded from the web, with version 1.3.8. All addresses are relative to the beginning of the firmware file. By performing advanced reverse-engineering techniques, the following results were achieved:

The firmware is called by a bootloader. Beginning address 0x00006284 was detected. This is a non-return function - at the end of it is an infinite cycle. The analysis must also be started at point 0x0000644A.

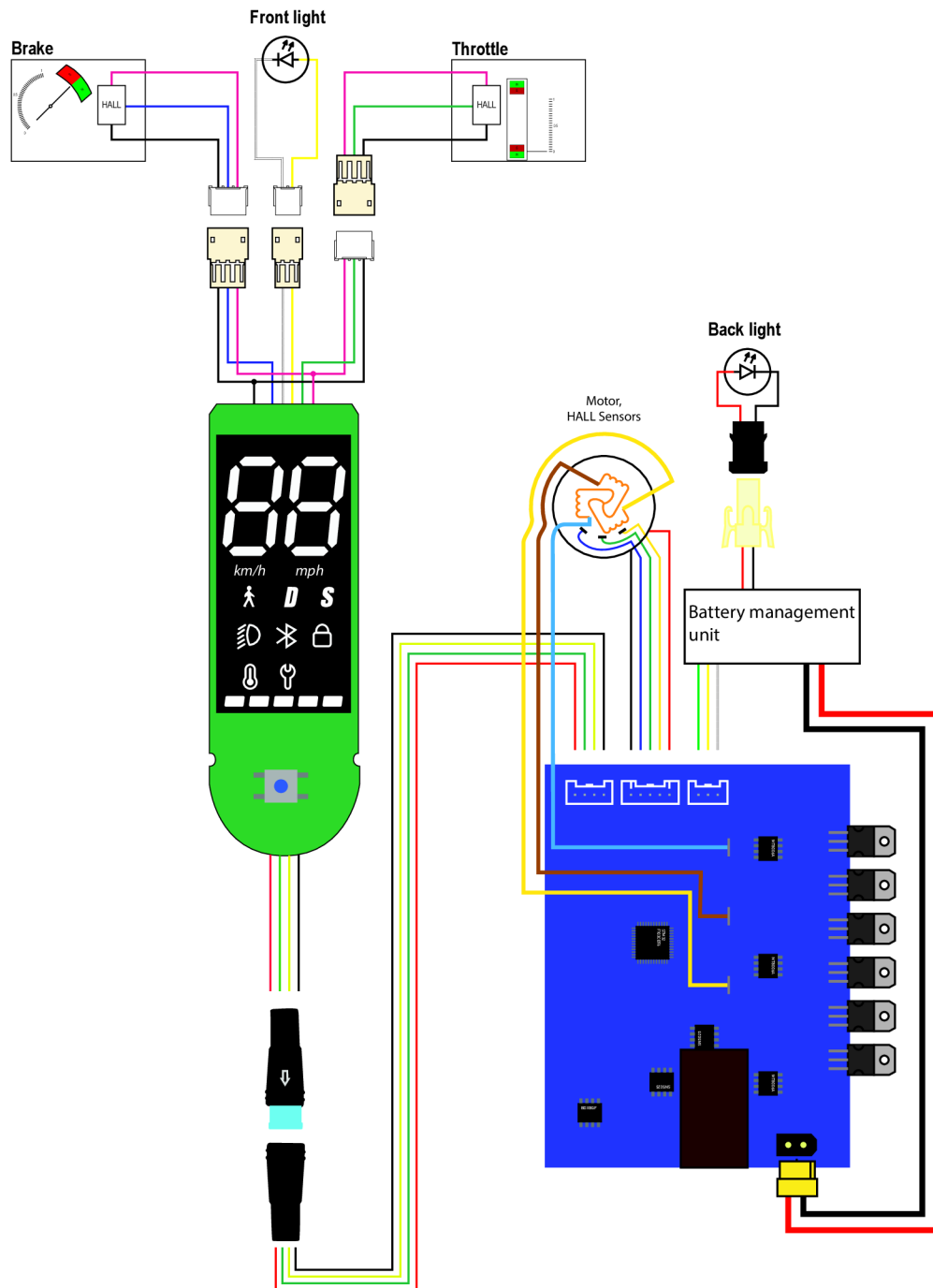

Figure 66: Electronics inside M365 pro 2

Firmware is logically divided into two main blocks. Motor control block and communication block. These two blocks run in a loop and their operation is complex. Reverse engineering was focused on the communication block. The ESC was found to receive frames from the BMS and switch them to the BLE line if necessary. Firmware uses a static memory model, that is, without memory blocks allocation.

BLE sends frames to the ESC every 20ms. Frames have a predefined structure. The protocol is designed to detect an error at the transport layer using a checksum at the end of the frame. The

frames are designed to send all the necessary data at once. If the frame is damaged, the ESC ignores the frame and accepts the next one. If the ESC does not receive more than 20 consecutive frames, it goes into emergency mode where it starts braking the motor. When communication is restored, the entire system recovers without the need of restartin BLE or ESC. Frame can be up to 256 bytes long.

This information was verified by several programmed state machines. The first state machine created was an edge detector, which was implemented on an ESP32 microcontroller. It scanned the one-wire line through which ESC and BLE communicate, and its captured data was send to a computer via UART. Effectively, a binary protocol capturer was created. The analyzed data of individual captured frames can be seen in Figure 67. To determine the distance between the frames, a conversion program was created that took the edge capture data from the ESP32 and created a .vcd file, which was opened in GTKWave. The information obtained was verified on an oscilloscope, just to be sure (Figure 69).

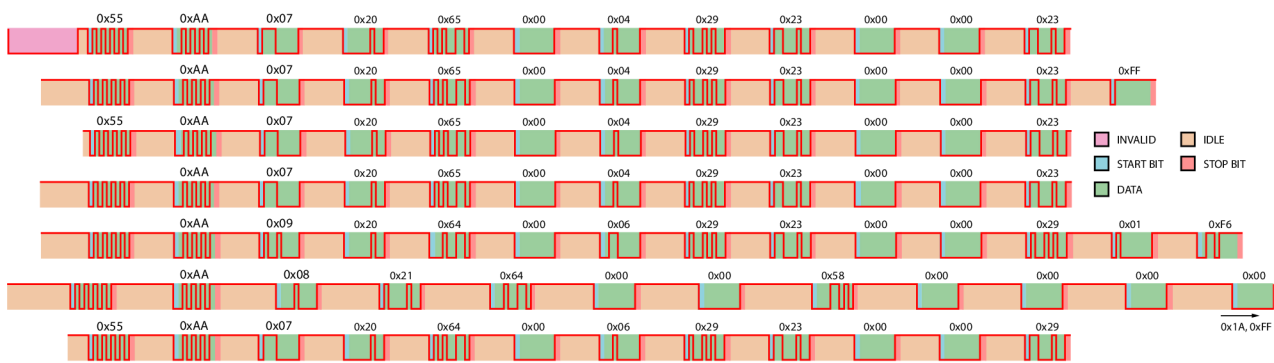

Figure 67: BLE - ESC communication with UART transfer stages

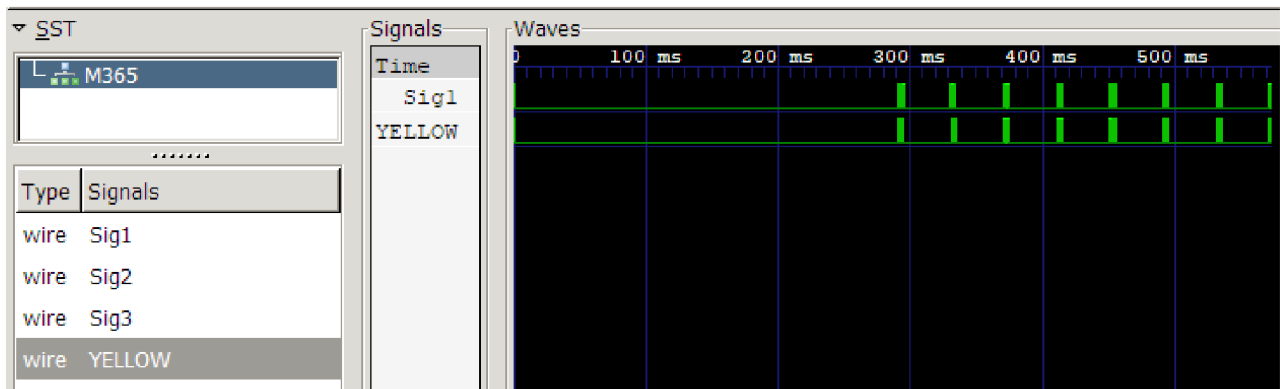

Figure 68: Converted capture file that shows transferred data on the one-wire

Another state machine designed was a frame switch. ESP32 was connected as an intermediate point between ESC and BLE. It transparently switched communication from one line to another and sent a copy of the communication to the computer. In this way, the communication direction of the frames was verified. Information about frames sent to the computer can be seen below. The first



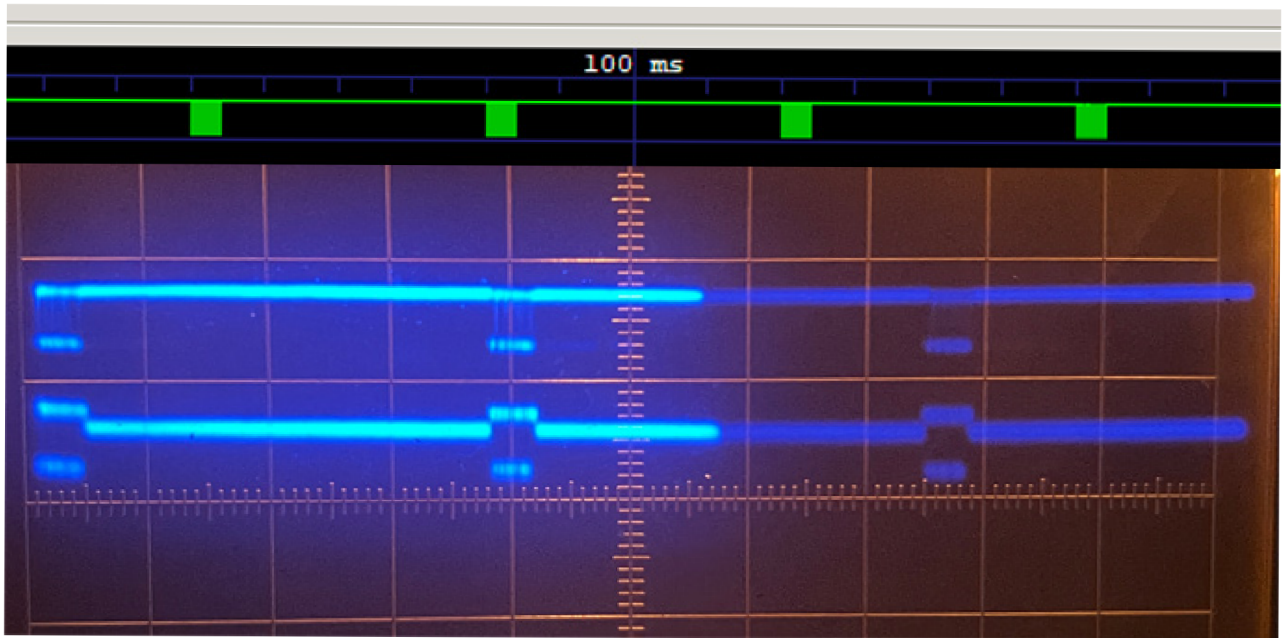

Figure 69: Distance between the frames. Captured and measured

letter is the source of the communication (B = BLE, E = ESC) and the rest is the content of the frame.

```

B 0x55 0xAA 0x7 0x20 0x65 0x0 0x04 0x29 0x23 0x0 0x0 0x23 0xFF
B 0x55 0xAA 0x7 0x20 0x65 0x0 0x04 0x29 0x23 0x0 0x0 0x23 0xFF
B 0x55 0xAA 0x9 0x20 0x64 0x0 0x06 0x29 0x23 0x0 0x0 0x29 0x01 0xF6 0xFE
E 0x55 0xAA 0x8 0x21 0x64 0x0 0x02 0x40 0x64 0x2 0x0 0x00 0xCA 0xFE
E 0x55 0xAA 0x2 0x21 0x01 0x0 0xDB 0xFF
B 0x55 0xAA 0x7 0x20 0x65 0x0 0x04 0x29 0x23 0x0 0x0 0x23 0xFF
B 0x55 0xAA 0x7 0x20 0x65 0x0 0x04 0x29 0x23 0x0 0x0 0x23 0xFF
B 0x55 0xAA 0x7 0x20 0x65 0x0 0x04 0x29 0x23 0x0 0x0 0x23 0xFF

```

BLE a ESC communicate with each other via one-wire UART. The status of the line in various phases from the BLE side is shown in Figure 70.

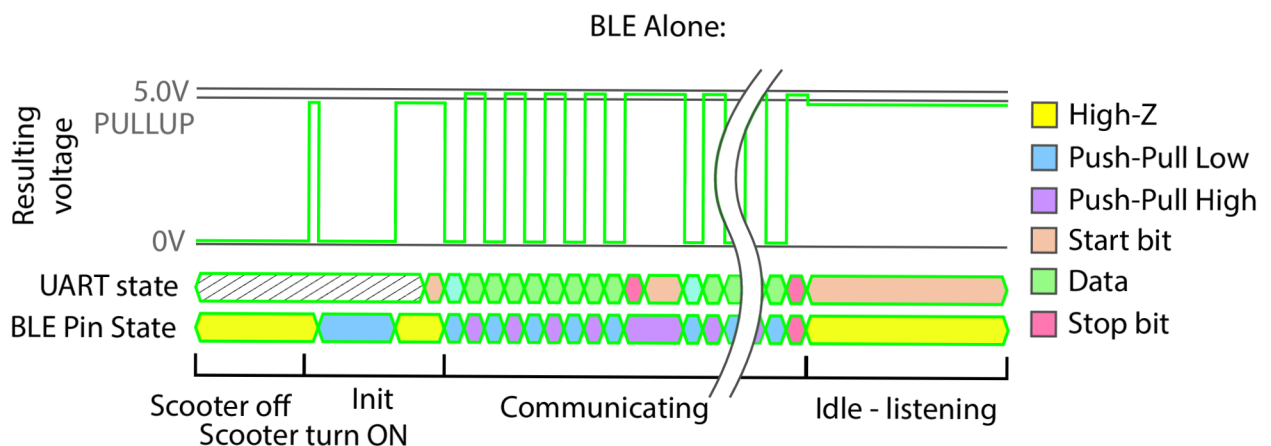

Figure 70: BLE driving the communication line

Communication format at the block diagram level is shown in Figure 71. On the link layer, the UART protocol is used between BLE and ESC with 115200 baud rate, 1 stop bit, without parity bit, implemented on one line. Between ESC and BMS is UART, 115200 baud rate, 1 stop bit, without

parity bit, on separate RX and TX lines. The frame on the data layer can be seen in the picture [72](#).

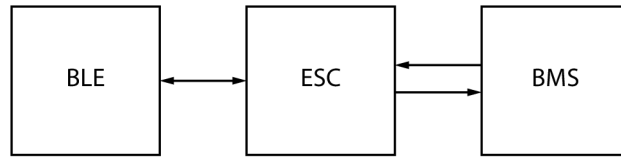

Figure 71: Block diagram of the communication inside the scooter

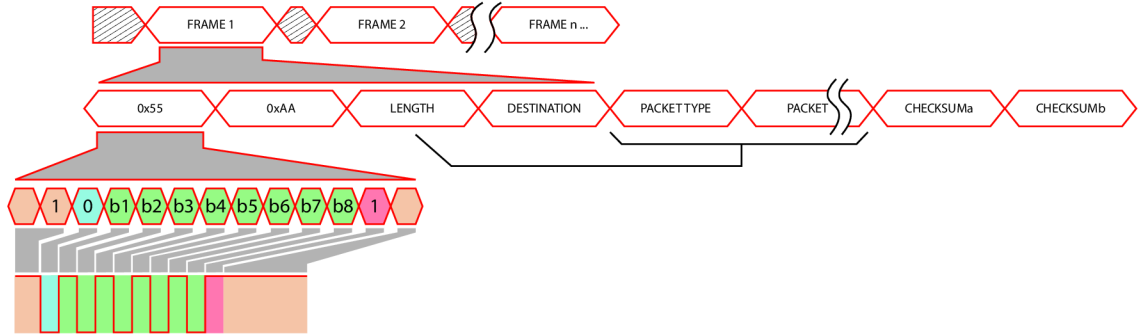

Figure 72: Communication protocol structure

DESTINATION	
0x20	REQ/INFO to ESC
0x21	REQ to BLE
0x22	REQ to BMS
0x23	RESPONSE from ESC
0x24	RESPONSE from BLE
0x25	RESPONSE from BMS
0x01	?

Figure 73: Meaning of destination fields

TYPE	DESTINATION									
	0x20		0x21		0x22		0x23		0x24	0x25
READ	0x01		0x01		0x01		0x01		0x01	0x01
?	0x02,0x03	UPDATE_INFO	0x64		0x23					
?	0x05									
PROBLEM	0x6-0x10									
INFO	0x18									
MEM_PROC	0x58									
PROBE	0x59									
CONF	0x5C									
MEMORY	0x61									
UPDATE_INFO	0x64									
BASIC_STATE	0x65									

Figure 74: Types of packets

Figure [73](#) shows the valid values in the destination byte. Figure [74](#) shows a table where each destination byte has a valid set of values in the type byte. When transmitter sends an orange byte, response may or may not be sent. This depends on the packet body and the runtime state of the ESC. Requests with green bytes always follow by a response. Red bytes means no response on the transmitted frame.

To command the ESC to rotate the motor, only three frames are needed, and they are shown in Figure [75](#)

<b>DST</b>	<b>TYPE</b>	<b>DATA</b>				
0x20	0x65	0x00	0x04	ACC	BRAKE	confirmation
<b>DST</b>	<b>TYPE</b>	<b>DATA</b>				
0x20	0x64	?	?	ACC	BRAKE	confirmation
0x21	0x64	0	STATE	BAT	NIGHT	confirmation

Figure 75: Important packets

## Design of the controller block

Controller block should mimic the actions of the original BLE module. The two motor control units internally contain a control loop similar to the one in Figure 51, but simpler. The goal of the control block is to send a synchronized speed command to both of these units. As a discrete feedback, both units send current speed to the control unit and this way a proper function can be verified. If the feedback is wrong, based on the read speed value, control software should compensate for this error between received speed and throttle position. If software does not detect a correction trend, it can safely cut the throttle and try to recover. Unless transfer function of the two controllers are known, this is the best approach. Several packets have been reverse engineered and all the required packets to drive a motor have been reverse-engineered. Implementation of the communication with other packets can extend the features, like nicely showing the speed and max speed, as illustrated in figure 76. The control block has potential possibility to implement a display and show voltage of each cell pack and lock the scooter without the application.

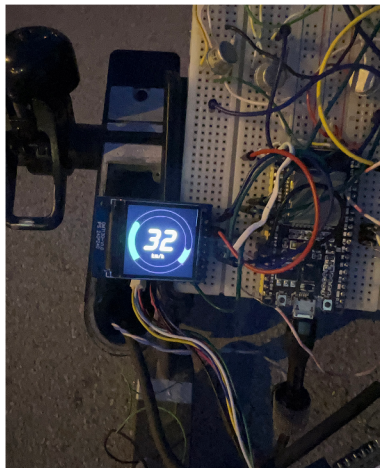

Figure 76: Custom LCD Dashboard

## Results

A wheel was mounted onto the frame. Original braking system was removed, because it touched the motor body in the back (Figure 77). Regenerative braking is still achievable. Another controller was attached to the battery and the back motor was attached to it. These controllers were placed inside the scooter. A cable for communication was carried from the bottom of the scooter to the top. This cable is in place of the braking rope. A controller on a breadboard was set up and the units as well as the braking and throttle were connected to it. This controller was programmed to control both of the motor controllers. This concludes the implementation details



Figure 77: Wheel mounted into the frame

### Testing and evaluation

The goal of testing is to evaluate the stability and reliability of the implemented solution under different circumstances. For a reliable testing, scooter should be driven for periods of one or two months during summer, where thermal problems can manifest, and winter, where problems with low temperature or slipping on snow could emerge. Thus, only a possible subset of the tests was performed.

Firstly, a simple control was implemented, where a synchronized speed information was sent to both of the units. Scooter was driven continuously for 30 minutes and driving was smooth. The scooter was driven several times across multiple days in shorter intervals. Slight problems arose only when driving through a very rough terrain. It seems that the algorithm inside the scooter is doing a good job in smoothing out possible inequalities between the two wheels. As soon as the ground coupling is present between the two control systems, fluent control is achieved. So adding a compensation system in the control block could introduce phase delay. It has thus been avoided. Predictions about the effects of scooter's increased power output in chapter 5 is verified, because the scooter's ability to drive on elevated terrain has notably improved. Also acceleration and braking speed has improved. The overall efficiency of the system appears to be decreased, which is understandable, as there are two systems creating losses instead of one. It is still a very nice upgrade and it was worth doing.

It can be concluded, that by doing reverse engineering on an original system and expanding that system, a newly designed control unit is able to drive a scooter with two motors, with a good driving experience.



Figure 78: Testing example

### Plans for the future

Several ideas of how this work could continue were collected as this solution was implemented. Firstly, the solution presented here works, but it is not known how much the battery is stressed. This could be analyzed by a similar state machine as was designed in this report to monitor a data line, but this time it would monitor the voltage on the battery.

Most interesting would be to finish the firmware reverse engineering. So far, about 19% of the firmware code was translated to C code, or its functions have been identified. With reverse engineering, the more is known, the faster it progresses, so the beginning where engineer knows nothing are most difficult. With complete assembly translation, control loop would be understood and it could be modified. Also, transfer protocol could be optimized and drive modes could be reconfigured. With an addition of a central control block with a display, the system would be way better than that provided by Xiaomi.

## 7 Conclusion

The goal of this thesis was to install a secondary motor onto the frame and to find and implement a way how to control both motors. This was successfully achieved and a dual-motor scooter with modified control system was put into controlled motion.

Literature was studied to an extent that would allow to design the controller from scratch, but the scope of possible problems set a the research on a different path. Main concepts regarding motor control are presented in this thesis.

The electronics inside the M365 Pro 2 scooter was analyzed and an extension to this system was proposed. This proposal was also chosen for implementation and reverse-engineering of the firmware and communication protocol was necessary to solve the control problem. Another option of scooter's motor control is proposed, which could add many additional features to the scooter control. Disadvantage of this option is price.

The implemented method not only drives both front and back motors at the same time, but also allows for the implementation of new software features. Another original motor and controllers were used and they were driven by a custom controller system based on the ESP32 microcontroller. This build was tested under different road conditions and the scooter drives smoothly almost all the time. Slight problems appeared when one wheel is in the air and the other is touching the ground. But this may be problem of all two-motor scooters, so it is acceptable.

The scooter was upgraded from one motor to two motors in under 120€. Additionally, a custom electronic system can be further customized, and put even more features into the scooter that would increase the user's driving experience. For future work, the controller unit should be integrated into a product that would be mounted in the place of the scooter's original dashboard, and stronger mechanism for back motor mounting must be implemented.

## Appendix A: Basics of electricity and magnetism

To understand the chapter about the motor, it is necessary to understand the basics of magnetism. The knowledgeable reader can skip this appendix. Physics explained here mainly helps to understand the part with permanent magnets and the basic principles of motor rotation. It should be noted that the terminology for marking magnetic parameters is extensive and one parameter may have multiple markings that differ by time, author, country or company. Currently accepted markings are standardized in ASTM A340 norm. In the lower part of this appendix, the so-called cgs system is used. It is a system named after centimetergramsecond and it is older than the standardized SI system. In this report, markings of both systems are shown for reference, because this system, despite being older, is still used. Some texts here are written in a way that it is expected that the reader understands the principle of the differential calculus, vector fields and concept of system modeling. This whole appendix introduces the ideas in as intuitive way as possible. Thus, it will be written informally.



Quantity: **Electric charge**  
 Unit: Coulomb [C]  
 SI unit: [Ampere · second]  
 Značenie: q  
 Description:

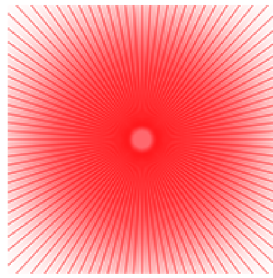

Figure 79: Charge of proton

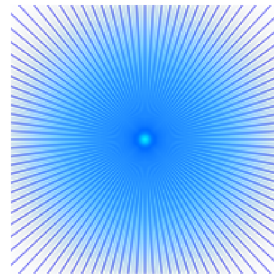

Figure 80: Charge of electron

Electric charge is a property of every indivisible unit of matter. In this case, the indivisible matter is protons, which are the source of the positive electric charge, and electrons, which in turn are the source of the negative electric charge. We mathematically model this phenomenon as the point at which the full force of the charge is located. This force propagates through space to infinity from the point of the source in all directions and thus weakens with distance. If we place this electrically charged particle, i.e. an electron or proton, in an electromagnetic field, a force will start to act on it. The same applies to objects composed of these particles. An atom, as a composite object, is composed of protons and electrons (and neutrons, but these do not show measurable signs of charge). If the number of electrons in an atom dominates, the atom has a negative charge, and when placed in a magnetic field, a force begins to act on it. Similarly, if there are fewer electrons than protons in an atom, a force will be applied to a positively charged atom placed in an electric field.

Amount of charge generated by one proton:  $1.602176634 \times 10^{-19}$  coulomb

Amount of charge generated by one electron:  $-1.602176634 \times 10^{-19}$  coulomb

Although the mass of an electron is much lower, its structural composition produces the same charge value as a much more massive proton. In standardized system (SI) units, the coulomb is defined as  $C = A \cdot s$ , which is a model for a situation where one ampere indicates the current of electrons, and there are so many of these electrons that they can form a 1 Coulomb charge together. This all takes 1 second. The ampere thus indicates the transmission of approximately 16'021'766'340'000'000'000 electrons through a cross section of space (over any distance) in 1 second.

Although electric charge is a more basic quantity than current, el. charge is derived from current

measurements because it is almost impossible to accurately measure something as small as one electron. Therefore, a reasonable number representing one basic unit of charge was not defined, and everything else would then follow. On the contrary, we work with measurements that comprise a large number of particles and the necessary parameters for modeling a single particle, such as electric charge, are calculated and approximated.

This explains the non-intuitive value of the charge. To correctly define a new model of a quantity, it is necessary to be able to experimentally measure the defined parameter. In the case of an electric charge, which is defined for an electron, it is not possible to reliably measure the relative value of the quantity.

If we had two groups of electrons, where we know that in one group there are 1000 electrons and in the other are 5000 of them, we would make a measuring device to measure our defined quantity and calibrate it to display 1000C in the first group and it would show the value of 5000C in the second group, we would reach an ideal state. In reality, however, we cannot create a group of the exact number of electrons that we could reliably measure. Therefore, we must be satisfied with the current elementary values.

Quantity:     **Electric current**  
 Unit:         Ampere [A]  
 SI unit:      [Ampere]  
 Marking:     I  
 Description:

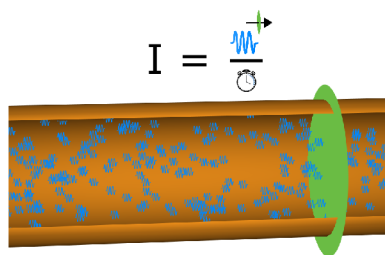

Figure 81: Electric current

Electric current is a quantity which models the act of passing a certain number of particles through a place over time. Transmission distance is irrelevant. If we take as a place the cross section of a conductor, then, if 1 coulomb of charge (ie about  $1.6 \cdot 10^{-19}$  in this case, electrons) passes through this cross section in one second, or half a coulomb of charge in half a second, we can say that 1 ampere of current flows through the cross section. The relationship between charge and time is thus:

$$I = \frac{C}{s}$$

In Figure 81, the electron is shown as a wave, not as a point or sphere. This is to make this conceptual current model more accurate. From the quantum physics point of view, an electron is a wave and it passes through the metallic structure of a conductor so that it ‘waves’ through. If we have a conductor with a temperature of 0 kelvin, i.e. an absolute zero, the electron would wave around the atoms of the conductor without any loss of energy and could flow through the conductor like this forever. However, if the conductor is warmer, the wave model of the conductor’s atomic structure interacts with the electron wave and slows it down. This effect would be depicted in the classical Drude model as a collision of a small sphere of an electron with a large sphere of the nucleus of a conductor’s atom.

Quantity: **Force**  
 Unit: Newton [N]  
 SI unit: [1 kilogram · meter<sup>2</sup> · second<sup>-2</sup>]  
 Marking: J  
 Description:

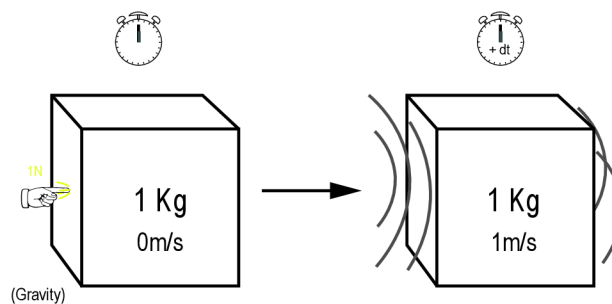

Figure 82: Force

Force is the basic unit of the whole field of physics - momentum. It is defined by a situation, where in order for some object A increasing the speed of object B by 1 meter per second, where object B weighs 1 kg, object A exerts a measurable force of 1 newton on the object B. Note that the time of this displacement plays no role in this unit and we do not care about the mass of the object but its weight in the gravitational field. Figure 81 shows two time point. In the first time point, we come across a kilogram block. At the atomic level, things are plastic, and in the plasticity of a kilogram block we create momentum. Something as if by the first object we stretched the spring of the kilogram block. After an infinitely small time, we are in the second time point, where nothing affects the kilogram block, but there is tension in its plasticity. After starting the time, this tension moves the object so that in one second of time, we measure one meter long passage through space in the direction of the tension in the block. The second time point in the figure therefore represents a potential for motion, and it only depends on time, what distance this block with this potential

(speed) travels. Force, mass and acceleration are bound together follows:

$$F = m \cdot a$$

or if we want to work in more dimensional space, we can use its vector form:

$$\vec{F} = m \cdot \vec{a}$$

Quantity: **Energy**  
 Unit: Joule [J]  
 SI unit: J  
 Marking: -  
 Description:

**Joule** represent a potential to exert a force or create heat. 1 Joule = work of force of 1 newton on an object during its displacement of 1 meter.

Quantity: **Magnetic field**  
 Unit: -  
 SI unit: -  
 Marking: -  
 Description:

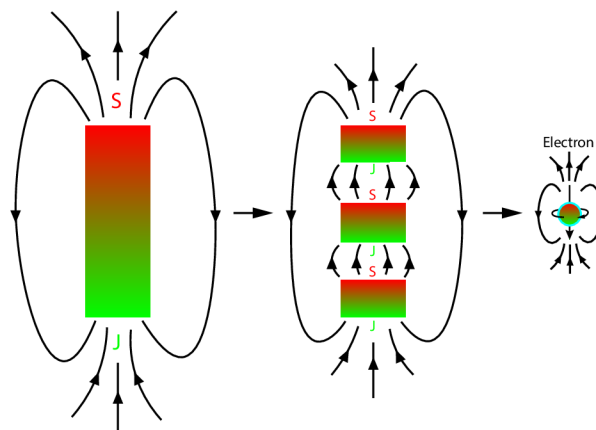

Figure 83: Magnetic field

Magnetism is a field of physics ,where things appear in such a way, that in various experiments we see a kind of effect of some single quantity - the magnetic field.

Let's take an ordinary bar magnet. We know it has a north pole and a south pole. If we drew imaginary lines, they would go from the North Pole to the South on the outside of the magnet, and inside, they would go from the South to the North, closing the loop (Figure [83](#)).

If we divided this magnet into the smallest particles possible, we would find (according to current knowledge) that a magnetic field that contains two poles - north and south, is always created by one object that produces both fields at the same time. So we don't find the North Pole or the South Pole separately. In the case of an electric field, on the other hand, we have a positive and negative field sources separated and do not find any elementary particle that would generate both of these fields at the same time.

Thus, we say that the elementary source of the magnetic field is a dipole. It is true even for the elementary source of the magnetic field, that on the outer side, the field travels from north pole to the south, and inside it closes from the south to the north.

We will now take a closer look at the elementary particle, which is the source of the magnetic field. In reality, this source is only an electron or a proton. Of this, protons are very massive in comparison to an electron, and neglecting special cases, we can say that they do not participate in the formation of a magnetic field. Thus, an electron is the main consequence of the formation of a magnetic field and can create this field in three ways.

1. The electron in the atom rotates around the nucleus and its motion creates a magnetic field in the atom. However, this field source contributes to the diamagnetic property of the atom (atom weakly repelled by the magnetic field)
2. From the quantum physics point of view of, an electron is a wave and has a property - spin. It indicates a state where an electron appears to rotate about its own axis at a certain speed. This spin creates a magnetic field in the space around the electron.
3. When an electron is set in motion relative to an observer, the electron creates a magnetic field in all directions for that observer. This field propagates in space at the speed of light and after some time it reaches the observer (time is relative, but we will not deal with it here). If the electron stops relative to the observer, this source of the magnetic field for the observer also disappears.

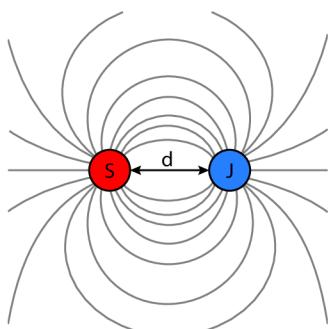

Figure 84: Dipole - Two monopoles

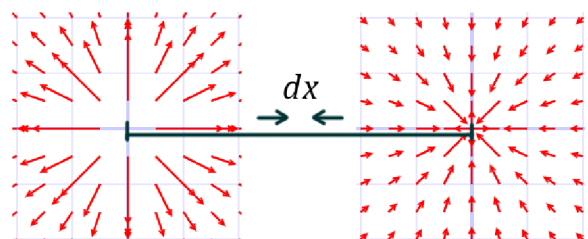

Figure 85: Dipole, monopoles - mathematically

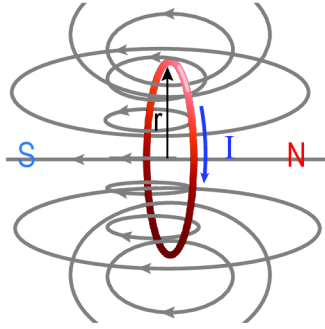

Figure 86: Dipole - Ring

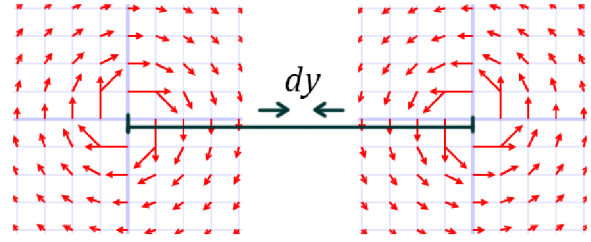

Figure 87: Ring dipole - mathematically

An electron is thus an elementary dipole that creates a magnetic field. Let's take its second way of magnetic field creation - spin. We take an electron as a small static magnet in space that creates its own magnetic field by an effect where its own electric charge rotates around its axis. So it is like a current of charge flowing through a loop. We know that a moving electric charge creates a magnetic field. This is exactly the third way how electron creates a magnetic field. So method 2 is practically method 3, but conceptually, it is good to separate them. We will explain method 2 in more detail: We model a static electron in the space by a dipole, as shown in Figures 84 and 86. We can create this dipole mathematically in two ways so that it also agrees with the physical property of the magnetic field that the electron produces.

The first method of mathematical modeling is a dipole with two monopoles. It consists of two units of vector field - radial source and sink. These sources and sinks represent the northern and southern monopoles respectively. They are stored at a distance of  $dx$  85, so it is a limit of mutual approach towards zero distance. At the same time, however, we must ensure that the strength of these two monopoles with relation to the distance between them remains constant. Then it will meet the physical property of the magnetic field that electron produces in this model. So the magnetic field that a magnetic dipole produces is:

$$\mathbf{H}(\mathbf{r}) = \frac{1}{4\pi} \left[ \frac{3\hat{\mathbf{r}}(\hat{\mathbf{r}} \cdot \mathbf{m}) - \mathbf{m}}{|\mathbf{r}|^3} - \frac{4\pi}{3} \mathbf{m} \delta(\mathbf{r}) \right]$$

The position of the vector in the H field represents the position from the dipole source. The direction of the vector represents the direction of the magnetic field and the length of the vector represents the strength of the magnetic field's H quantity.

The second way is a loop, where the current flows. Here we try to reduce the radius of the circle until the circle becomes just a point. In order for the model to be correct from a physical point of view, we must keep the product of the current and the surface the same when reducing the radius. The magnetic field is then:

$$\mathbf{B}(\mathbf{r}) = \frac{\mu_0}{4\pi} \left[ \frac{3\hat{\mathbf{r}}(\hat{\mathbf{r}} \cdot \mathbf{m}) - \mathbf{m}}{|\mathbf{r}|^3} + \frac{8\pi}{3} \mathbf{m} \delta(\mathbf{r}) \right]$$

An atom that is made up of these electrons produces a magnetic field if more of the electrons have a similar spin orientation and do not interfere with each other.

Quantity: **Magnetic flux**  
 cgs unit: Maxwell [Mx]  
 SI unit: Weber [Wb]  
 SI unit:  $[10^{-2} \cdot \text{Kilogram} \cdot \text{meter}^{-2} \cdot \text{second}^{-2} \cdot \text{ampere}^{-1}]$   
 Marking:  $\Phi$  or  $\Phi_B$   
 Description:

The magnetic field mentioned above can be represented by magnetic field lines. Each source of the magnetic field, whether it is an orbiting electron around a nucleus, an electron rotating around its own axis (spin), or an electron flowing through a conductor, creates these field lines which scatter in the environment until they close up.

Quantity: **Magnetic flux density**  
 Unit: Tesla [T]  
 SI unit:  $[\text{Kilogram} \cdot \text{second}^{-2} \cdot \text{ampere}^{-1}]$   
 Marking: B  
 Description:

It is also directly called **magnetic field**. Note that the magnetic field in terms of magnetic flux density (B) is used in electromagnetism and magnetostatics, while the H component is used only in magnetostatics. Otherwise they are relatively interchangeable quantities modeling the same thing, but in a different frame of scope.

Magnetic field density refers to the amount of magnetic field lines going through an area, for example  $1 \text{ cm}^2$ . The magnetic field can also be created by a moving charged particle according to the equation:

$$\vec{B}_{point\ charge} = \frac{\mu_0}{4\pi} \cdot \frac{q\vec{v} \times \hat{r}}{r^2}$$

Magnetic field in mathematical modeling is a vector field.

Magnetic flux density is also called **B field**

Magnetic field is created by the spinning of electrons in the shell of atoms. This means that an atom is like a small magnet, if most electrons have the same spin from the outside look on the atom. If we have many of these atoms in one place, and they are all rotated in the same direction, the density of the magnetic field that this cluster creates is bigger. If we distributed these magnetic

field generating atoms evenly in a plastic polymer, for example, the measured magnetic field across a surface of an imaginary sphere would be the same as in the first case, but the source of this field would be broader and weaker.

Also, a charged particle moving relative to a reference point generates a magnetic field for that point.

Quantity:     **Magnetization field**  
 Unit:            A/m [A/m] or Oersted [Oe]  
 SI unit:         [Ampere/meter]  
 Marking:        H  
 Description:

Magnetic field interacts with the environment by two different effects. One is the magnetization of matter, and the other is the application of force to another source of magnetic field. Magnetization function is described by the magnetization field (called the H field). It is a modeled component of the magnetic field and is mathematically modeled by a vector field. The magnetizing field is created by any source of magnetic field. A permanent magnet or a moving charged particle (hence the electric current).

Quantity:     **Residual induction**  
 SI unit:        Tesla [T]  
 cgs unit:       Gauss [G]  
 Tesla (SI):    [Kilogram · second<sup>-2</sup> · amper<sup>-1</sup>]  
 Gauss (cgs)   [1 Maxwell / cm<sup>2</sup> alebo 0.0001 Tesla]  
 Marking:       B<sub>r</sub>  
 Description:

Also called **residual magnetization** or **Residual polarization**.

It indicates the amount of magnetic induction in an object after it has been magnetized by an external field. This object can be a magnet or a piece of iron.

For magnets, it indicates how strong the field they create.

The figure [88](#) shows a B-H curve, also called the hysteresis curve. It names a magnetic field change around the magnet placed in a device called permagraph. This device can create a stable magnetic field between two plates, which we model with an H vector field. The device can also measure magnetic induction between the two plates. The Y axis directly displays the measured magnetic field (B field) between the instrument plates. The strength of this field is a combination of the B field of the magnet and the B field of the instrument (although the above H field is included, the



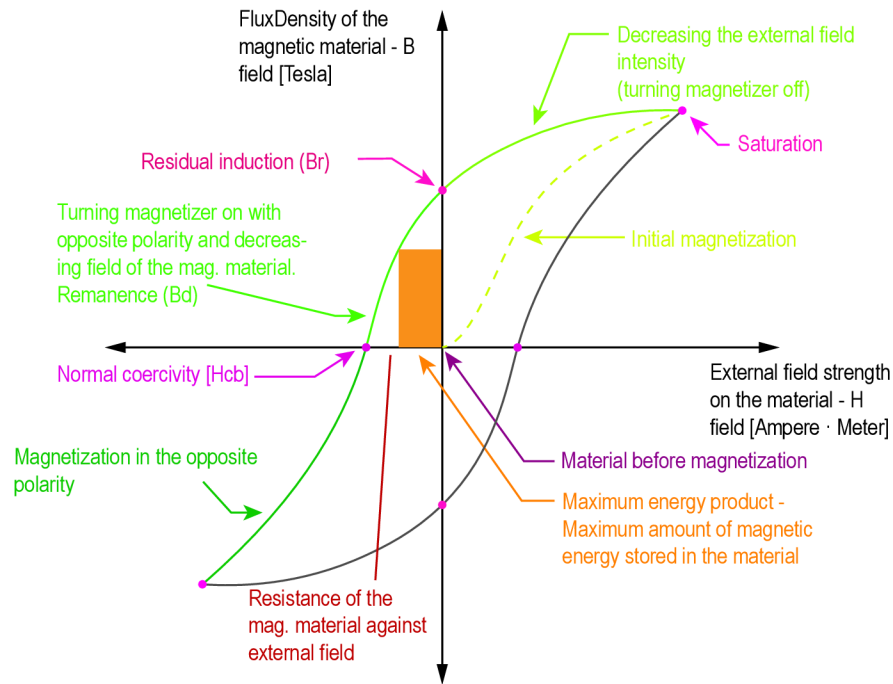

Figure 88: Remanence

B component of the instrument field is included in this product). On the X-axis is purely a magnetic field of the instrument (H component).

Remanence is a point on this curve where the instrument no longer generates a magnetic field ( $x = 0$ ), but the instrument still measures a quantity of the magnetic field between the plates ( $y = B^r$ ). Thus, the magnetic material induced the field from the external field of the machine, which it now holds (fig. 88).

It is only valid at a certain temperature (normally 20 °C). At higher material temperatures, the magnetic field density decreases, and when the operating temperature of the magnet is exceeded, the magnet loses the magnetic field density until it is remagnetized again.

Quantity:	<b>Normal coercivity</b>
Unit (SI):	Ampere/meter [A/m]
cgs unit:	Oersteds [Oe]
Oersteds(cgs):	$[4 \cdot \pi \cdot \text{kA/m}]$
Marking:	$H_{cj}$
Description:	

Or just **Coercivity**, or **Coercive field strength** Normal coercivity is the point on the BH curve, where the field of the magnetic material is completely neutralized by the opposing external field. So the total field in the system is 0. The field that the magnetic material produces, at this point, is not yet forced in the opposite direction by the external field, and if the external field stops working, the field of the magnetic material recovers to the original remanence value.

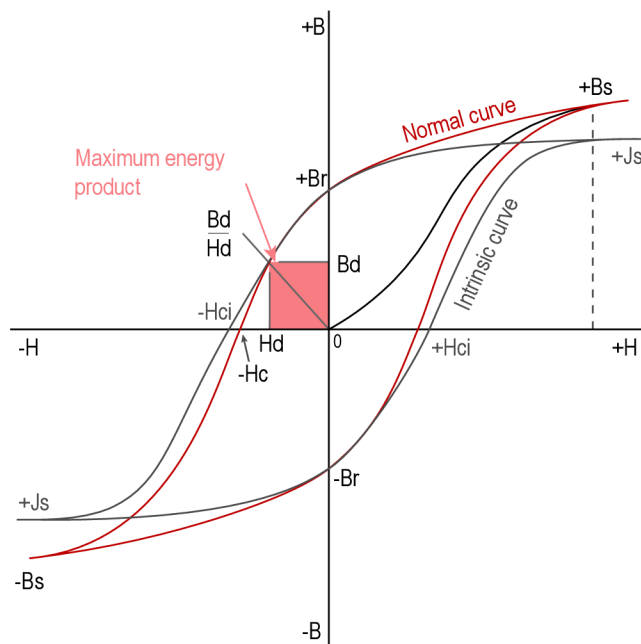

Figure 89: Normal curve

If the opposing external field crosses the normal coercivity point, the magnetic material is exposed to the opposite polarity and the remanence point begins to decrease, so the magnet weakens, and if we want to restore its original remanence point, we must bring it back to saturation by the external field. After removing the magnetizing field, the magnetic material again offers the maximum field density.

- Quantity: **Intrinsic Coercivity**
- SI unit: Ampere/meter [A/m] (SI) cgs unit: Oersteds [Oe]
- SI unit: [Ampere/meter]
- cgs unit:  $[4 \cdot \pi \cdot \text{kA/m}]$
- Marking:  $H_{ci}$ ,  $H_{cj}$ ,  $iH_c$ ,  $mH_c$
- Description:

On the normal curve we see the measured value of the magnetic field (B), together with the component of the field that is formed by the permagraph. However, we may be interested in what external field strength is created by the magnet alone, at a given moment of measurement. The curve that shows only the component of the magnetic material in the B-H curve is called the intrinsic curve. The remanence is the same as in the normal curve, because the permagraph is switched off at that place ( $x = 0$ ) and does not produce an external field component.

The combined field at the normal curve is equal to the field generated by the magnetic material at the remanence point. However, important are the points of intrinsic coercivity. These are the two points at both sides of polarization of the magnetic material on the BH curve, where the ability of the

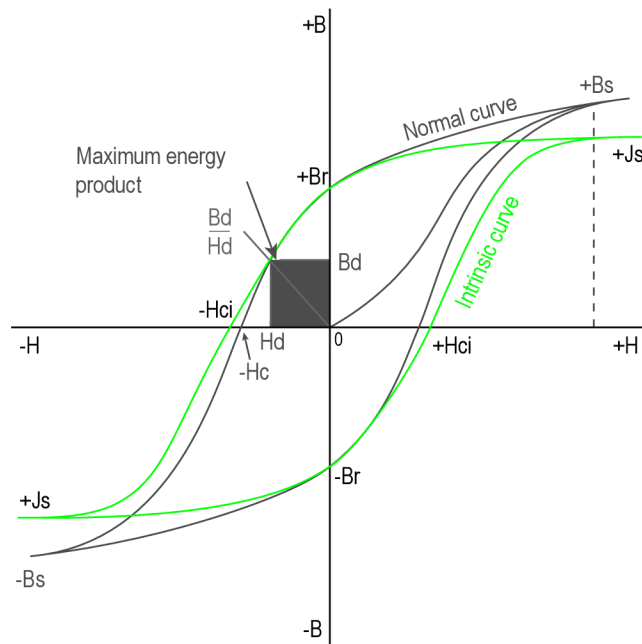

Figure 90: Intrinsic curve

magnetic material to generate the field was brought to zero by an external counter acting field. The remanence reaches zero. This weakens the magnet until it loses the ability to create a field. Such magnetic material can be magnetized back to any polarity as long as there is no physical damage to the material. The intrinsic coercivity therefore models the ability of the material to withstand demagnetization, while the normal coercivity only shows the net zero measured field at the surface of the magnet combined with a certain strength of the opposing external field.

- Quantity: **Magnetic permeability**
- SI unit: Ampere/meter [A/m] (SI) cgs unit: Oersteds [Oe]
- SI unit: [Ampere/meter]
- cgs unit:  $[4 \cdot \pi \cdot \text{kA/m}]$
- Marking:  $H_{ci}$ ,  $H_{cj}$ ,  $iH_c$ ,  $mH_c$
- Description:

If the permeability of a material is high, such as iron, if a source of a magnetic field (e.g. a magnet or a coil) is moved to the iron, the atoms in the material very easily reorient and guide this field from where the magnet is, through the iron, outside. Thus, iron has a very low magnetic resistance (reluctance).

## Lorentz law

A charged particle (electron or proton) sees only two things in space, to which it can react (if we do not take into account quantum phenomena). Electric field and magnetic field. If a particle is exposed to any of these fields, something will happen to it. It should not be forgotten that the charged particle creates its own electric field, but the reaction of the particle with its own field is not relevant now. The following equation describes what a charged particle does in space with two fields that are of an interest to the charged particle:

$$\vec{F} = q\vec{E} + q(\vec{v} \times \vec{B})$$

We have a charged body composed of charged particles (i.e. electrons and protons). For example, a closed group of electrons (for this example, we do not care about their repulsive properties between each other). What interests us in this group is their common charge, which we denote by the letter 'q' (in coulombs). This closed group has its center.

If the group of these charged particles is in an electric field and this field has a magnitude 'E' in the middle of the group, force on this group is a vector whose direction is opposite to the direction of the el. field, and the vector size is: Product of the amount of charge in the group and the strength of the magnetic field in the center of the group. In other words, the more charged particles, the greater the force acting on the group, and the greater the magnitude of the external electric field, the greater the force acting on the group.

Second part of the equation (after +) describes what happens to a group of charged particles, when a magnetic field acts on it. The charge of the group of charged particles is multiplied by the vector resulting from the 'crossing' of the velocity direction with the direction of the field, which is provided by the  $\times$  operation of these two vectors.

The velocity vector has two values. Direction is the direction of the speed and the length determines the speed at which the group moves in that direction.

Magnetic density vector has also two values. Direction determines the direction of the field (from north to south) and the length determines the density of the magnetic field at the center point of the group of charged particles.

The charged particle begins to move away from the field. This result is provided by a cross-product of group's velocity and the magnetic field density in the middle of the group. This resulting vector determines the direction and magnitude of the force for the whole group of electrons. The bigger this group, the greater the total force in the same direction (multiplication of q with the result of operation  $(v \times B)$ ).

In Figure [91](#), you can see that if the electron moved in line with the magnetic field (it would not intersect any field line but would go straight with them), this field would exert no force on the

particle.

An aid to remember the direction of the force: By the right hand rule, thumb goes in the direction of the proton's velocity. Around the proton, its own magnetic field is created in the direction of the fingers. The same directions are repelled in the same way as the same magnet poles repel. The opposite attract. The direction of force is the same as the direction of repulsion and attraction of these two fields. The force on electron is opposite to that of proton. This is the principle of motion for charged particles.

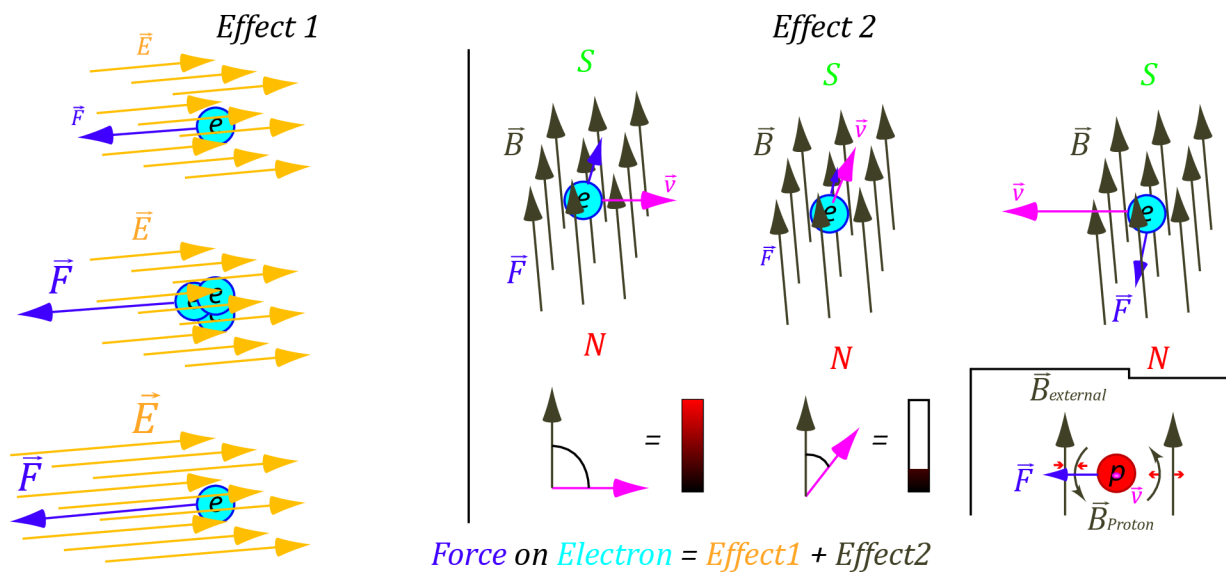

Figure 91: Principle of Lorentz law

### Conductor in a magnetic field

Figure 92 shows a state in which we have a conductor with current of electron placed in a magnetic field with density and direction  $B$ . You can notice that the current is the amount of charge over time, this could be represented as density of electrons, because the more of them passes through the cross section per second, the bigger the conductor, or the faster they have to go through the thinner conductor. Also the length of this conductor in the field is important. The longer the conductor in the magnetic field, the more electrons feel the strength of the magnetic field along conductor's entire length, and these electrons pull the entire conductor structure in the direction in which the force acts. The whole conductor starts moving through space.

Relationship between the force on the conductor, conductor length, current through the conductor and density of the magnetic field in which the conductor is located, is as follows:

$$\vec{F} = (l \cdot \vec{i}) \times \vec{B}$$

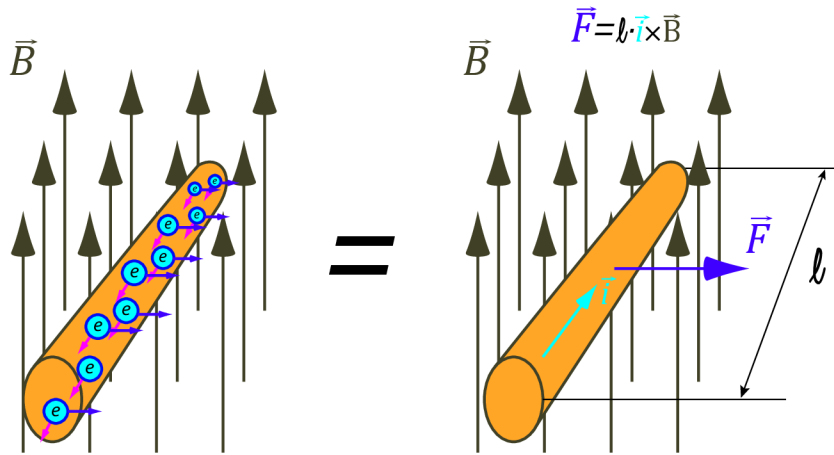

Figure 92: Force on a current in a magnetic field

## Faraday's law

Michael Faraday has discovered and formally published a phenomenon, where it is not possible for the magnetic flux that passes through a metal loop to change too quickly. One phenomenon ensures that the magnetic flux does not change too quickly. As the magnetic flux through the loop changes, a voltage is induced in the loop, a current begins to flow through the loop, and this current creates an opposite magnetic field that fights against the change of the original field, and thus the original field changes more slowly.

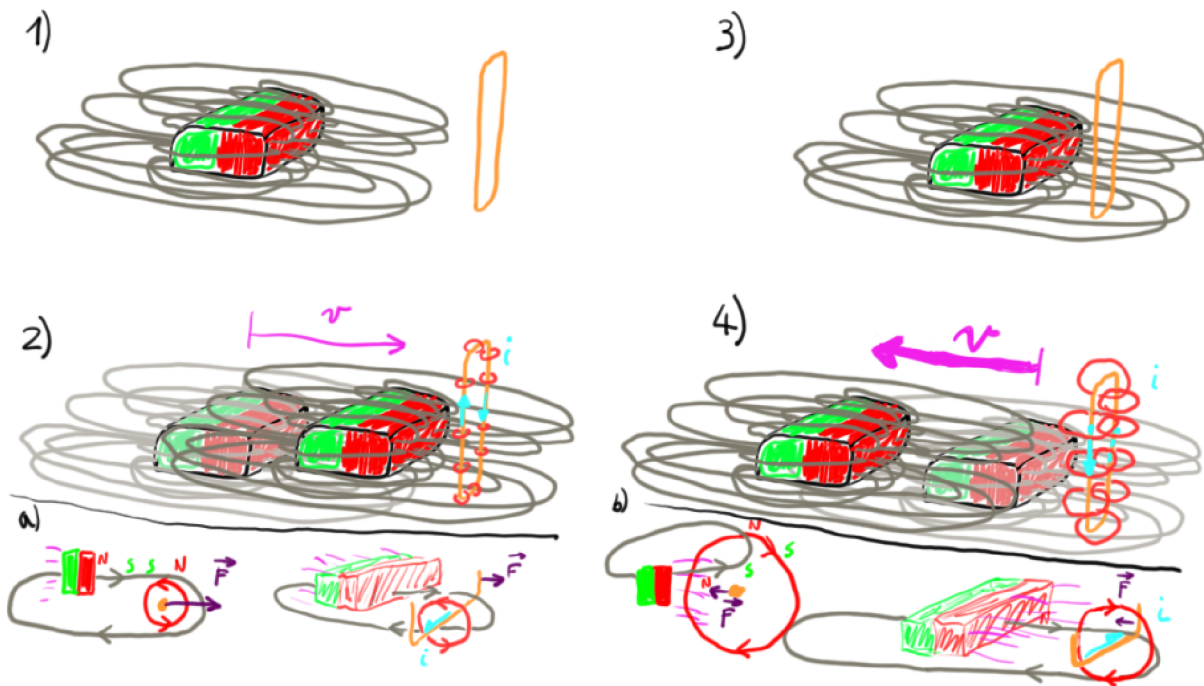

Figure 93: Faraday's law

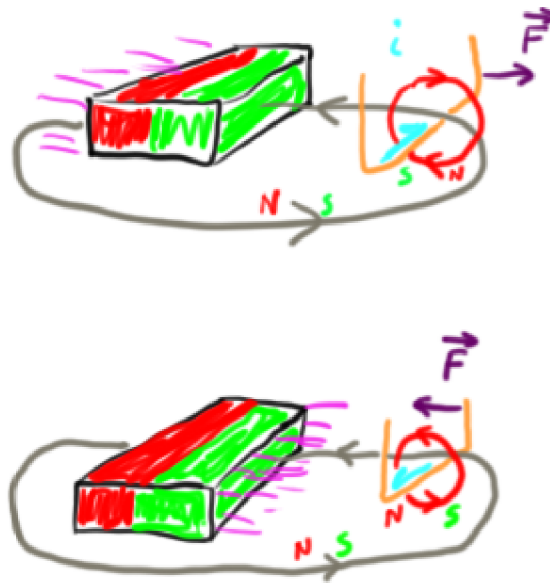

Figure 94: Faraday's law, reverse polarity

In Figure 93 we have a model situation. A stationary copper loop is placed in the space and next to it there is a magnet (part 1). In part 2, the magnet approaches the loop at the designated place with certain velocity. The magnetic field at the loop rizes and the electrons feel the driving force. The current is starting to flow. This stream of electrons creates its own magnetic field. This field is drawn in red at the bottom left. In addition to a current generation on the loop because of the approaching magnet, the two magnetic fields - the field of the loop and the magnet's field interact against each other. The magnet is shown at the bottom left and the arrow on the field line marks its polarity. It can be seen that the poles of the magnet and that of the loop are the same and the loop tries to repel the magnet. Violet lines represent magnet's motion.

Now, magnet is not moving and is close to the loop (part 3). Now the magnet rapidly pulls away from the loop. The loop responds. The electrons in the loop feel a strong change in the magnetic field and are rapidly pushed in the conductor. A rapid current starts to flow. This fast current creates a stronger magnetic field than the one in part 2. This field interacts with the field of the leaving magnet and a force is created on the loop towards the leaving magnet. If there were no losses in the system, and we pushed or pulled on the loop, the loop would always move exactly the same with the magnet and a constant distance would be achieved (assuming homogeneous field of the magnet at the place of the loop and loop being perpendicular to the field). This principle explains why a magnet frozen close to absolute zero levitates below or above a conductor (with many details neglected).

It is good to realize that in the first case, the loop felt an intensifying north field. In the second case, as the magnet left, the loop felt a weakening north field. Therefore, the current induced by the amplifying north field is opposite to the current induced by the weakening north field. For

clarification, the strengthening south pole and the weakening north pole induce current in the same direction. But whether we are approaching the loop with the north or the south pole, the loop will always try to repel the magnet. The loop will be attracted to the magnet if the magnet leaves the loop, facing the magnet with either the north or the south pole. This is shown in Figure [94](#).

Another addition is that in order to induce a current in the loop, the magnet does not have to approach and move away from the loop. Induction occurs due to a change in the magnetic field and this can also be achieved with a rotating magnet around the loop. In this case, the current is first induced in one direction, and as the magnet turns by the opposite pole, the current stops and begins to flow in the other direction. As the magnet rotates about its axis near the loop, alternating current is induced in the loop. This principle converts rotary motion into electrical energy and is the basis for the working principle of generators in power plants.

As an interesting idea, I would like to add that nothing is for free. If we have a generator where we rotate the magnet by hand and we have an open loop, the electrons feel the change in the magnetic field and a force acts on them. These electrons begin to form a current, but as the loop is disconnected, the current rapidly disappears. All that the little initial current did is, that it pushed the electrons to one disconnected end of the loop and the electrons left the other end. Voltage has developed on the loop. As the magnet rotates, very small currents flow through the loop which only moves the charge from one end of the loop to the other. Since no strong current flows through the loop, the loop does not fight against the changing field of the magnet and we rotate the generator very easily. But if we connected a light bulb to the loop and we started spinning the generator, the rotating magnet would induce a current that would start flowing through the light bulb and it would start to glow. This current fights against the magnetic field of the magnet and we feel it as a resistance during magnet rotation. When the bulb is on, the generator rotates harder.

## **Appendix B: Clarke transform**

Many one-dimensional reference lines which are rotated or even shifted from the original plane can be placed the plane, which is a two-dimensional reference. Any combination of values in these  $n$  reference lines can be redrawn into a vector on the original plane. In Clarke transformation, three reference lines are placed on the original plane. They are rotated by  $120^\circ$  from each other. When performing Clarke transformation, we take three values on these three rotated reference lines, transform them, and the result is one vector on the original plane that is equivalent to the joined vectors in the direction of three one-dimensional lines. This principle is visualized in Figure [95](#). The letters representing the components of the vectors in the matrices are 'i', which stands for current, but in general, any marking may be used.

It is important to note, that we are interested in transformation of quantities on their respective



A B C axes, into  $\alpha$  and  $\beta$  axes. The vector which is made by combining these quantities is not important, but we can notice, that it is the same before and after transformation. Only the components that represent the vector have changed.

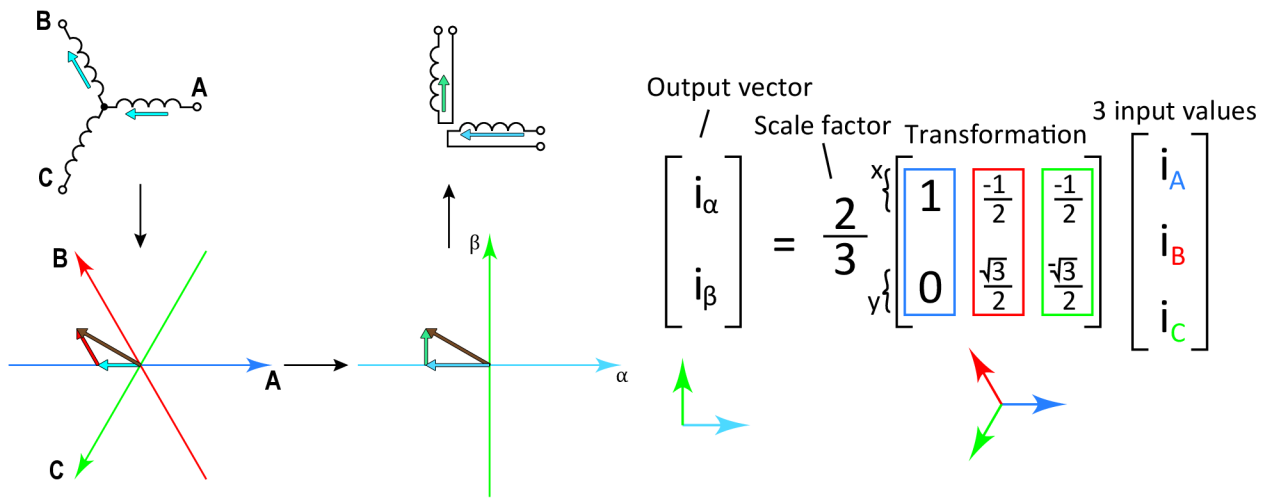

Figure 96: Clarke transformation

Figure 95: Clarke transformation principle

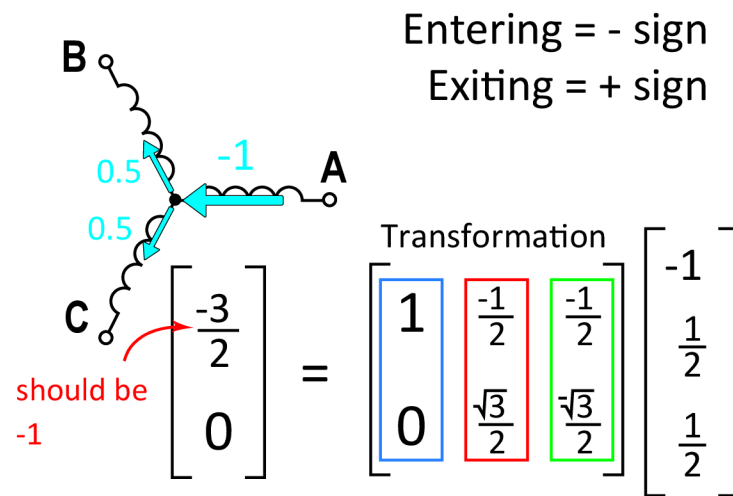

Figure 97: Why multiplier in the transformation

This transform can be simplified into the following form:

$$i_A + i_B + i_C = 0$$

$$\frac{1}{2}i_A = -\frac{1}{2}(i_B + i_C)$$

$$i_\alpha = i_A$$

$$i_\beta = \frac{i_B - i_C}{\sqrt{3}}$$

## Appendix C: Park transform

We have two planes. Each plane has its x and y axis. These two planes have a common center point. The first plane is static. The second plane is angularly rotated from the first plane around the same centerpoint. Park transformation takes an X and Y value (vector) from the first plane and transfers it to the X and Y values (vector) of the second, rotated plane. Figure 98 shows these two planes where the second one is rotated.

Figure 99 represents the principle where we transform the input vector components of the first plane into equivalent vector components of the second, rotated plane. The vector that is formed by both components before and after the transformation is the same as in the original plane. Thus, the vector from the stationary plane is just projected to the values that represent it in the rotated plane.

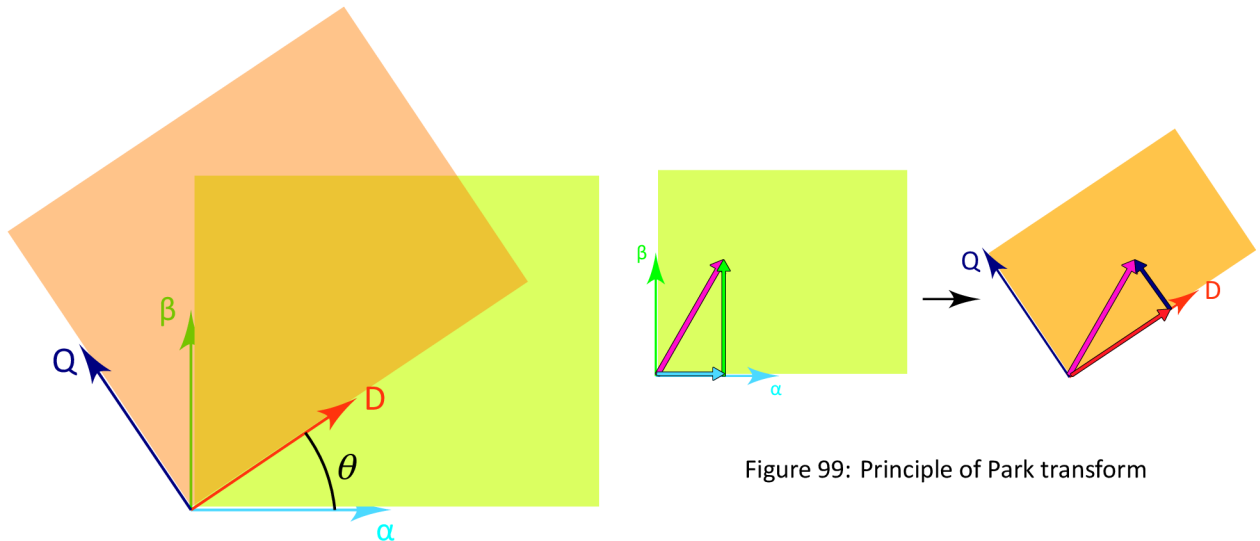

Figure 98: Planes of Park transform

Figure 99: Principle of Park transform

$$\begin{bmatrix} i_D \\ i_Q \end{bmatrix} = \begin{bmatrix} \cos(\theta) & \sin(\theta) \\ -\sin(\theta) & \cos(\theta) \end{bmatrix} \cdot \begin{bmatrix} i_\alpha \\ i_\beta \end{bmatrix}$$

$$i_Q = -\sin(\theta) \cdot i_\alpha + \cos(\theta) \cdot i_\beta \quad i_D = \cos(\theta) \cdot i_\alpha + \sin(\theta) \cdot i_\beta$$

## References

---

- [1] DUALTRON Thunderer User Manual, Minimotors Co. LTD., Lanxi, 2019, Zhejiang, B321H003-18002
- [2] DUALTRON X Series User Manual, Minimotors Bike Co., Ltd., Lanxi, Zhejiang
- [3] P. Van den Bossche, SAFETY CONSIDERATIONS FOR ELECTRIC VEHICLES, 2003, CITELEC, Pleinlaan 2 1050 Brussels Belgium
- [4] Robert Thomson, Recommendations for New Safety Requirements and Research, Deliverable No. 4.2, Workpackage No. 4, Electromobility+
- [5] Guide to Verifying Safety-Critical Structures for Reusable Launch and Reentry Vehicles, Version 1.0, Federal Aviation Administration, Washington, DC, 2005
- [6] Michelle Schneeweiss, Mohammed Hassan-Ali, April Kam, Safety and risk factors associated with electric scooter use globally: A literature review, McMaster University, MUMJ Vol. 18 No. 1, pp. 48-60, 2021
- [7] Thermal stability of MOSFETs rev. 1, Semiconductor Components Industries, LLC, Denver, Colorado, 2014, AND8199/D
- [8] George Lakkas, MOSFET power losses and how they affect power-supply efficiency, Texas Instruments, Analog Applications Journal, Dallas, Texas, SLYT664
- [9] Yingying Gui, Bingyao Sun, Rolando Burgos, Desaturation Detection for Paralleled GaN E-HEMT Phase Leg, Center for Power Electronic Systems, Virginia Tech Blacksburg, VA, USA, 2018
- [10] Johan Strydom, Dead-Time Optimization for Maximum Efficiency, WHITE PAPER: WP012, EPC-CO, El Segundo, CA, 2019
- [11] Alex Lidow, eGaN® FET Drivers and Layout Considerations, WP008, EPC-CO, El Segundo, CA, 2016
- [12] Sanjay Havanur, Beware of Zero Voltage Switching, System Applications, Vishay Siliconix, Santa Clara, California 95054
- [13] M. Hartmann and J. W. Kolar, "Analysis of the trade-off between input current quality and efficiency of high switching frequency PWM rectifiers," The 2010 International Power Electronics Conference - ECCE ASIA -, 2010, pp. 534-541, doi: 10.1109/IPEC.2010.5543283.
- [14] Cycle Analyst V3.1 User Manual Rev1.0, Grin Technologies Ltd. Vancouver, BC, Canada, 2019
- [15] GANRUNNER GNRR-1500S, FTEEx, 642 rue de Courcelle, Montreal, 2021
- [16] Béalal Provencher, GaN Transistors Taking Center Stage in Power Electronics, FTEEx, 642 rue de Courcelle, Montreal, 2021
- [17] James Robert Mevey, SENSORLESS FIELD ORIENTED CONTROL OF BRUSHLESS PERMANENT MAGNET SYNCHRONOUS MOTORS, Kansas State University, Manhattan, Kansas, 2006
- [18] Austin Hughes, Bill Drury, Electric Motors and Drives: Fundamentals, Types and Applications, 4th edition, Newnes, 2013, ISBN:9780080983325
- [19] Kwang Hee Nam, AC Motor Control and Electrical Vehicle Applications, 2nd edition, CRC Press, Boca Raton, Florida, 2018, ISBN: 9781138712492
- [20] Hwang, Liu, Teng, Design and analysis of a novel inset permanent magnet synchronous motor, Journal of Magnetism and Magnetic Materials 320 e283–e286, 2008
- [21] Wei Tong, Mechanical Design of Electric Motors, CRC Press, Boca Raton, Florida, 2014 ISBN: 9781420091434
- [22] Bieńkowski, K.; Łapczyński, S.; Szulborski, M.; Kozarek, Ł.; Gołota, K.; Cichecki, H.; Kolimas, Ł.; Żelaziński, T.; Smolarczyk, A.; Babiński, A.; Owsiański, M. Validated Analytical Model of 8/6 and 10/8 Switched Reluctance

Motors. *Energies* 2022, 15, 630. <https://doi.org/10.3390/en15020630>

- [23] Karyś, S. Advanced control and design methods of the auxiliary resonant commutated pole inverter. *Bulletin of the Polish Academy of Sciences Technical Sciences*, 2015, 63. 10.1515/bpasts-2015-0056.
- [24] Steve Corrigan, *Introduction to the Controller Area Network (CAN)*, Texas Instruments Incorporated, Dallas, Texas, SLOA101B–August 2002–Revised May 2016
- [25] Bimal K. Bose, *Power Electronics And Motor Drives: Advances and Trends*, Burlington, MA, 2006, ISBN: 9780120884056
- [26] David Jauregui, Bo Wang, and Rengang Chen, *Power Loss Calculation With Common Source Inductance Consideration for Synchronous Buck Converters*, Texas Instruments Incorporated, Dallas, Texas, TSLPA009A, June 2011
- [27] *Mi Electric scooter specification*, Xiaomi Technology Netherlands B.V., <https://www.mi.com/uk/mi-electric-scooter/specs/>