



VYSOKÉ UČENÍ TECHNICKÉ V BRNĚ
BRNO UNIVERSITY OF TECHNOLOGY



FAKULTA STROJNÍHO INŽENÝRSTVÍ
ENERGETICKÝ ÚSTAV

FACULTY OF MECHANICAL ENGINEERING
ENERGY INSTITUTE

CONTROL SYSTEM OF BUILDING USING MODELLING AND SIMULATION

ŘÍDICÍ SYSTÉM BUDOVY S VYUŽITÍM MODELOVÁNÍ A SIMULACE

DOCTORAL THESIS

DIZERTAČNÍ PRÁCE

AUTHOR OF TREATISES
AUTOR

Ing. MOHAMAD KHEIR MOHAMAD

SUPERVISOR
VEDOUCÍ PRÁCE

doc. Ing. JOSEF ŠTĚTINA, Ph.D.

Brno 2014

Abstract

Maintaining of the indoor climate conditions so that they keep compatible with the occupants comfort is a key issue for control of heating, ventilation and air conditioning systems (HVAC systems). Computer modelling offers a virtual environment similar to real climatic conditions indoors and outdoors. It aims basically to devise solutions for control of indoor climatic conditions. This process requires understanding of these environments from physical and mathematical perspective, so that physical processes of these environments can be represented using relationships and equations which can reflect the influence of different environmental parameters. Then simulation process offers the possibility to describe the interaction between these models and their behaviour over time. It gives default representation of those environments and allows understanding of their behaviour before transferring these models to real applications. MATLAB/SIMULINK software has an advanced ability to simulate HVAC systems by creating a wide working environment for the designers depending on the development of mathematical models and simulating them by SIMULINK so that results output could be compatible with the desired conditions. This thesis addresses the process of modelling the indoor environment in buildings in order to understand the behaviour of key parameters which affect the thermal comfort of the occupants. The mathematical models of the indoor environment of a classroom have been designed with three basic indoor parameters: concentration of carbon dioxide, air temperature and relative humidity. Changes of these parameters over time have been simulated. Then, control strategies have been proposed for these parameters in order to keep them under the appropriate conditions of the occupants, although changing of climate outdoors, thermal and mass loads indoors. Through mathematical methods, some optimization methods have been proposed in order to reduce energy consumption without affecting the permissible limits of these parameters. Validation process of the model has been carried out by comparing the results with the real outputs monitoring by Honeywell Enterprise Buildings Integrator system installed in the classroom.

Keywords

HVAC systems, indoor environment, comfort, modelling, simulation, control strategy.

Abstrakt

Udržování vnitřních klimatických podmínek tak, aby byly v souladu s tepelným komfortem lidí, je klíčovou otázkou pro řízení systémů vytápění, větrání a klimatizace (HVAC systémy). Počítačové modelování nabízí virtuální prostředí pro simulaci vnitřních i vnějších podmínek a s jeho pomocí je možné navrhnout řešení pro řízení technických zařízení budov. Tento proces vyžaduje pochopení těchto prostředí z fyzikálního a matematického hlediska tak, aby bylo možné fyzikální procesy daných prostředí prezentovat pomocí vztahů a rovnic odrážejících jejich různé parametry. Simulační proces dále nabízí možnost popsat interakci mezi těmito modely a jejich chování v čase, dává výchozí reprezentace těchto prostředí, a umožňuje pochopení jejich chování před přenosem těchto modelů do reálných aplikací. Simulace umožňuje respektovat, a ovlivňovat jejich chování přes kontrolu navržených modelů. MATLAB/SIMULINK software má pokročilé schopnosti pro simulace systémů HVAC, a to vytvořením širokého pracovního prostředí pro designéry v závislosti na vývoji matematických modelů a jejich simulace pomocí SIMULINK, aby výsledky mohly být slučitelné s požadovanými výstupy. Tato dizertační práce se zaměřuje na proces modelování vnitřního prostředí v budovách, aby bylo možné pochopit chování klíčových parametrů, které mají vliv na tepelnou pohodu obyvatel či uživatelů, matematické modely vnitřního prostředí posluchárny byly navrženy speciálně pro tři základní parametry: koncentrace oxidu uhličitého, teplota vzduchu a relativní vlhkost. Změny chování těchto parametrů v průběhu času jsou simulovány a poté strategie kontroly návrhu těchto parametrů může je udržet ve vhodných rozmezích komfortních pro obyvatele či uživatele, i když změny venkovního klimatu, tepelné a hmotnostní zatížení interiéru. Pomocí matematických metod, některé optimalizační metody byly navrženy za účelem snížení spotřeby energie bez vlivu na mezní hodnoty těchto parametrů. Proces validace modelu se provádí porovnáním výsledků s reálnými výstupy monitoringu Honeywell Enterprise Buildings Integrator systémem (EBI) nainstalován v areálu univerzity.

Klíčová slova

HVAC systémy, vnitřní prostředí, komfort, modelování, simulace, strategie řízení.

Bibliografické citace

Mohamad, Mohamad Kheir. *Řídicí systém budovy s využitím modelování a simulace*. Brno: Vysoké učení technické v Brně, Fakulta strojního inženýrství, Energetický ústav, Odbor termomechaniky a techniky prostředí, 2014. Disertační práce 142 s. Vedoucí práce doc. Ing. Josef Štětina, Ph.D

Čestné prohlášení

Prohlašuji, že jsem disertační práci na téma *Řídicí systém budovy s využitím modelování a simulace* vypracoval samostatně pod vedením svého školitele doc. Ing. Josefa Štětiny, Ph.D. s použitím podkladů uvedených v seznamu použitých zdrojů.

V Brně dne 11. 3. 2014

Ing. MOHAMAD KHEIR MOHAMAD

Acknowledgment

I would like to wish peace to the soul of my mother, my brother, my friend and my relatives who died during the past two years of my study here...Your absence hurts me more than anything!

Your souls have inspired me in my work, and given me the motivation to continue despite all the obstacles and difficulties.

I wish you were waiting for me when I come back, and could see your faces, smiles, and kiss your foreheads!

This work is for you...to your timeless memories living in my soul!

I would also like to express great thanks to my supervisor Mr. Štětina Josef, doc. Ing., Ph.D. for his guidance, valuable comments, and for all he has done for the successful completion of this work.

I also deeply thank Mr. Charvát Pavel, Ing., Ph.D for his valuable advices which were very important in the preparation of this work.

I thank all the staff of the department, all my colleagues and friends in the office, who have created ideal working conditions during my study, and helped me a lot.

I thank my university in Syria, especially Mr. Ayman Youssef, Ing., Ph.D who was assiduous to care my affairs in spite of all the difficulties.

I thank my family in Syria which has remained patient in spite of all what happened after my departure...My dear father, my dear sisters, and my dear fiancée...You all have suffered a lot during my absence, but without your withstanding, I would not be able to withstand till this moment!

Thanks to all the nice people I have met in the Czech Republic. They have given me a lot of human warmth and love, and made me love the Czech Republic as if it is my second home.

Contents

1	INTRODUCTION	3
1.1	Definition of the objectives	4
1.2	Arrangement of work	5
1.3	Limits of work	6
2	INDOOR ENVIRONMENT	7
2.1	Thermal comfort	7
2.2	Indoor air quality	9
2.3	Humidity in building	10
2.4	Heat transfer in building	12
3	OUTDOOR CLIMATE DATA	16
3.1	Meteorological station TUBO	16
3.2	Processing of weather data by using MATLAB/SIMULINK software	20
3.3	Processing of weather data by using TRNSYS software	24
3.3.1	<i>Basics and background</i>	24
3.3.2	<i>TRNSYS model</i>	27
4	MODELLING INDOOR THERMAL PROCESSES	30
4.1	Basics and background	30
4.2	Modelling heat transfer indoors	35
4.2.1	<i>Model of heat transfer through external walls</i>	37
4.2.2	<i>Model of heat transfer through windows frame</i>	47
4.2.3	<i>Model of heat transfer through roof</i>	49
4.2.4	<i>Model of heat transfer through windows</i>	51
4.2.5	<i>Model of heat loss/gain due to ventilation</i>	52
4.2.6	<i>Model of internal gains</i>	53
4.3	Control strategy	54
4.4	Calculate heat removed/added	57
5	MODELLING CO₂ CONCENTRATION INDOORS	60
5.1	Background	60
5.2	Mass balance model of indoor carbon dioxide	61
5.3	Traditional base/forced ventilation model	62
5.4	Demand controlled ventilation (DCV) model	63

6	MODELLING HUMIDITY INDOORS	66
6.1	Background	66
6.2	Relative humidity model.....	67
6.3	Control humidity model.....	70
6.4	Model of detecting condensation on the walls.....	75
7	VALIDATION AND RESULTS.....	78
7.1	Enterprise Buildings Integrator (EBI)	78
7.2	Results.....	79
8	CONCLUSION.....	101
	References.....	104
	List of publications of author	109
	List of symbols and abbreviations	110
	List of Appendices.....	113

1 INTRODUCTION

Heating, ventilating and air-conditioning (HVAC) systems are multi-variables systems, which are one of the largest consumer of energy in buildings. These systems provide warmth and cooling, humidity control, indoor air quality, and provide comfort for the occupants. Despite great advances in HVAC systems but there are still wide fields of research, where, HVAC systems are constantly being developed in recent times, especially with the expansion of architectural buildings, and industrial renaissance taking place in the world.

Indoor air quality directly affects human health. In many countries there is a rise in health problems with increasing dissatisfaction with indoor air quality in buildings. A lot of scientific fields have been developed to search in these issues and address their details.

Because HVAC systems consume so much energy, buildings must have the potential to achieve significant savings by improving control strategy of processes being done by HVAC systems so that improves the efficiency. HVAC systems are usually designed for maximum heating and cooling loads such as solar ambient temperatures, thermal loads, occupancy size, etc. These conditions usually change through the day, so deviations from the set points may cause technical faults, and the inability to perform the tasks required. For this reason, HVAC capacity is designed to be greater than the real loads. Without control system, HVAC may overheat or overcool indoor spaces.

Modelling and simulation HVAC systems and their control systems are becoming increasingly important steadily, because the dynamic simulation using special software is the most efficient way to investigate controllability and to control performance of these systems. It is well known that the dynamic performance of a HVAC system has a great impact on energy consumption, as well as on indoor environment. Hence, it is clear how much the importance of modelling and simulation to address these issues.

Modelling is the process of design a model, which represents a system or phenomenon, or any subject being searched and investigated. The model is similar to the real system but simpler than it. The model is designed to predict the effect of conditions or any changes to the system, but the model should be very close to the real system from a physical and structural standpoint, and must include most of its properties. On the other hand, the designed model should not be so complex so that it is impossible to be understood well.

Model validation is very important part in modelling, which includes simulating the model at known conditions, and comparing results with real results which can be obtained by measurements.

A simulation of a system is the representation of how the model operates. Making and experiment the designed model directly is expensive and impractical process. Hence, simulation is the way to evaluate the performance of the system at different conditions over time.

Simulation process is usually applied before converting the model to real subject, in order to check the performance and reduce the chances of failure to meet specifications required, in addition to optimize system performance.

In this thesis, some methods of modelling and simulation using the computer have been designed to obtain the appropriate indoor conditions, with lower costs resulting from energy consumption.

1.1 Defining the objectives dissertation

In this work, an integrated model of controlling indoor climatic conditions within a building has been designed. These parameters are basically temperature, relative humidity and CO₂ concentration.

Practically, computational models are typically used when it is either impossible or impractical to create experimental conditions in which scientists can directly measure outcomes. Direct measurement of outcomes under controlled conditions are always more accurate than modelled estimates of outcomes. In order to achieve this objective, it is necessary to determine the best values of the required parameters indoors. The changes of climatic conditions outdoor must be taken into account. It means that the desired model must be an adaptable and adjustable model.

The goal of the work can be summarized by the following main points:

- 1 Design a computer model by using MATLAB/SIMULINK software and TRNSYS software to simulate and control the optimal indoor climate conditions in a building (office, library, school, theatre). This model achieves the following tasks:
 - a. Modelling the outdoor climatic conditions, and achieving the possibility of interaction with their changes. This task requires that the desired model provides the ability to store outdoor climatic conditions, as well as their changes according to the climatic conditions of the region where that building is located. The building considered in this thesis is a lecture room at the Faculty of Mechanical Engineering at the Brno University of Technology.
 - b. The model of solar radiation data has been designed by using TRNSYS software which can provide a suitable simulation environment to model climate change. While the other conditions (outdoor temperature and relative humidity have been simulated by exporting the real data taken from meteorological station in Brno (TUBO station) to MATLAB/SIMULINK, so that they can be used as outdoor conditions of the model.
 - c. Modelling the indoor temperature, with the possibility to control it according to the requirements of the occupants. This task requires taking into account thermal loads indoors, and simulating all the heat exchange processes to and from the room in order to be taken into account when calculating the heating and air conditioning (cooling) loads, for example: heat transfer from the walls, floor, windows and lamps, people, computer, etc.
 - d. Modelling the indoor relative humidity, with the possibility to control it according to the requirements of the occupants. This task requires modelling all the processes generating/removing moisture in order to calculate the moisture content in the indoor air in order to obtain the desired relative humidity which achieves the optimum thermal comfort of the occupants, and modelling the influence of other physical processes on the moisture content such as processes of heat transfer.
- 2 Modelling the indoor concentration of carbon dioxide, CO₂, with the possibility to control it according to the requirements of the occupants. This task requires modelling the mass flows of air to and from the inside of the lecture room, as well as their impact on the concentration of CO₂, taking into account the percentage of allowable CO₂ concentration in the air for the occupants commensurate with the degree of human activity inside.

3 Optimize indoor conditions in order to reduce their changes as much as possible by means of suitable control strategies, which can also reduce energy consumption. This task can be achieved by connecting process control of air quality with the monitoring of the concentration of carbon dioxide, so that by using this process it would be possible to bring in only the needed amount of outside air to maintain the concentration of carbon dioxide within the allowable values. This process saves the energy needed for the process of air-conditioning.

1.2 Arrangement of work

Content of the work is divided into three main tasks:

- 1 Obtaining the weather data. Then converting these data into format readable by the model by using MATLAB/SIMULINK software and TRNSYS software, so that they represent the virtual environment simulating the real outdoor climatic conditions of the place where the building is located.

Weather data have been obtained from meteorological station in the city of Brno in the form of Text Documents which can be downloaded online from the website of the meteorological station. Then these data can be exported to MATLAB/SIMULINK software in the form of MAT files, so that they become ready to be used in the model. The obtained data are: outdoor air temperature, relative humidity and the intensity of solar radiation.

Values of temperature and relative humidity have been converted into MAT files, and then exported to MATLAB/SIMULINK directly.

As for the available values of the intensity of solar radiation, these values represent the intensity of radiation incident on the horizontal surface, so it is necessary to find some way from which to take advantage of these data to calculate the intensity of solar radiation incident on the external walls in the building, which are vertical surfaces with different orientations, not horizontal. The solution has been proposed by creating a model by using TRNSYS software, where, the intensity of solar radiation incident on each external wall of the building can be calculated by using the values of temperature, relative humidity and the intensity of solar radiation on horizontal surfaces after knowing values describing the geographical location of the building, and azimuth angles of the walls.

- 2 The second step is modelling the basic parameters of the indoor environment, which are: temperature and relative humidity, in addition to modelling the concentration of carbon dioxide to check the quality of indoor air.

The basic principle for modelling the indoor temperature is the principle of conservation of energy, through calculation of heat flows to and from inside the building, with what it takes from prior knowledge of the thermal properties of all layers of the walls, and the mechanisms of heat flow through them, taking into account all gains and losses in the heat inside, if any.

While the basic principle for modelling the relative humidity is the principle of conservation of mass, through calculation of mass flows of water vapour in the air to and from inside the building, with what it takes to know the mechanisms of these flows.

As for the modelling the concentration of carbon dioxide, has been done also depending on the principle of conservation of mass through calculation of mass flows of carbon

dioxide to and from inside the building, with what it takes to know the mechanisms of these flows.

- 3 The third step is to propose strategies in order to control the indoor environment, so that it can maintain the conditions of indoor climate within the allowable range comfortable for the occupants, through modelling the basic processes of the air-conditioning system. At the same time they lead to the reduction of energy consumption by reducing the amount of air that is brought into inside building. Then, the results have been compared with the results of monitoring system installed inside the building to check the validity of these strategies.

1.3 Limits of work

- Weather data which have been taken into consideration are temperature, relative humidity and the intensity of solar radiation, but there are other data have an impact on the processes of heat and mass transfer, such as wind speed, its direction and actual atmospheric pressure, etc. Thus, neglecting their effects will affect the accuracy of the results.
- The indicator used for the indoor air quality is the concentration of carbon dioxide, with no discussion of the impact of other contaminants which can be present in the air.
- Modelling the basic processes of air conditioning is just limited to the modelling heat flow which must be supplied to or removed from the building in order to obtain the indoor temperature required, with proposing an approximate calculation of the minimal or maximum amount of heat flow needed, and then calculation of the approximate temperature of the air conditioner (The temperature of air supplied to the classroom) needed to get these amounts of needed heat.
- On the other hand, the control of the relative humidity is just limited to control of the rate of adding/removing of water vapour to/from the inside air, in order to obtain the indoor relative humidity required, without a discussion of technical details about how to apply these processes. In addition to propose some way to calculate the required rate of adding/removing water without the need to use the psychometric chart by relying on the principle of mass balance, as well as relationship of change in mass flow of water vapour to/from inside the building, and the relative humidity in the indoor air.

2 INDOOR ENVIRONMENT

Health problems caused by the surrounding environment are not related to the outdoor environment only, but also are related to the indoor environment. Air quality and indoor conditions have significant effects on human health. Because people spend most of their time inside buildings, especially in the winter, so they may be exposed to a lot of factors which can cause health problems. Indoor environmental problems can cause respiratory infections, allergic diseases from contaminants, or harmful reactions to chemicals used in industrial processes. The effects of indoor air quality (IAQ) on productivity became recently an important issue, due to understanding of the connections between variety of factors such as ventilation, pollution, indoor contaminants and their effects on human health and his comfort. There is growing concern of the impact of indoor environments on the health of occupants of the buildings, as well as the comfort and performance. Therefore, residential buildings, offices, schools and industrial facilities should be designed so that be maintained at appropriate conditions through some ways to reduce the sources of pollution, as well as provide adequate ventilation of fresh air through natural and mechanical means, while maintaining the temperature and humidity within the appropriate conditions, taking into account the special cases such as allergies or asthma. Hence, the lack in dealing appropriately with any of these issues will adversely affect the health, comfort, and performance of occupants.

2.1 Thermal comfort

It is well known that the human body generates constantly heat by a range from about 75 W during sleeping, to about 1000 W during extreme exercise [1], where excess amounts of heat should be transferred to the surrounding environment by radiation, convection, conduction and evaporation in an accurate and carefully controlled way, so that the internal organs of a human must remain at a constant temperature in order to maintain comfort, health and survival. This value is about 37.0 ± 0.5 °C. The maximum deviation of the temperature from the normal level is about 2 °C [2].

The human body has an accurate system to regulate the temperature, which checks whether that the body's core temperature is kept at specific temperature. The basic task of the human thermoregulatory system is to keep the core temperature constant [3]. This system consists of thermoreceptors and hypothalamus. The thermoreceptors are located in different parts of the body, and they have the ability to send signals about the temperature level and its change to the hypothalamus. Each type of thermoreceptor can be activated through a specific range of temperatures. When a thermoreceptor is subjected to a sudden change in temperature, it is will be stimulated quickly. This effect is called "overshoot" [4]. Skin is the basic part for dissipating heat from the body, where, the human body dissipates about 85% of its heat loss through the skin at normal environmental conditions [4]. On the other hand, thermal sensation is the body sense of temperature, which expresses the response of thermoreceptors. It is impossible to define this property through physical or psychological meaning, because thermal sensation is based on how people feel [5]. The thermosensitivity of the skin changes among different body parts. Hence, the thermal sensation and thermal comfort calculation should take into account this changing, especially in spaces with uneven surface temperature distribution [3].

Thermal control in the body is based mainly on peripheral blood-flow through the narrowing or expansion of blood vessels (vasoconstriction or vasodilation), in order to modify skin temperature, and thus regulate the heat exchange.

Thermal comfort describes the synthesis of feeling about thermal conditions in human body. The definition by ASHRAE (American Society of Heating, Refrigerating and Air-Conditioning Engineers) is “the condition of mind in which satisfaction is expressed with the thermal environment” (ASHRAE 2004). When people are not satisfied with the surrounding environment, the result is not only a potential health hazard, there are also impacts on their ability to perform their works effectively, and their comfort at work and so on. It is not easy to accurately explain the thermal environment of the human being, and cannot be expressed in a specific degree. There is no comprehensive definition within a specific range of temperatures acceptable for all occupants. But, based on personal experience depends on a large number of factors, where, can be different from one person to another within the same space. Where [1]:

- Thermal comfort is associated with the thermal balance of the body, which is itself affected by environmental and personal factors [5]: Environmental parameters: air temperature, mean radiant temperature, relative air velocity, relative humidity.
- Personal parameters: activity level or metabolic rate, thermal resistance of clothing.

Achieve thermal comfort is the result of a combination of environmental conditions, such as temperature of the indoor air, mean radiant temperature, relative humidity and air movement, which can be summarized as follows [1]:

- a. Temperature of indoor air greatly affects the occupants comfort and their perception of the environment. If the temperature of the indoor air is very warm, occupants may feel upset with little airflow. This case can lead to fatigue and lethargy. Moreover, higher temperatures may cause an increase in outgassing and toxins from the furnishings building materials and fittings, etc. On the other hand, if the ambient temperature is too cold, it can cause discomfort to occupants, such as shivering, muscular and joint tension.
- b. Mean radiant temperature is determined by surface temperatures, such as the temperature of walls, ceilings and windows, where, these surfaces radiate/extract heat to/from surrounding surfaces including the human body which can potentially causes discomfort.
- c. Relative humidity is a measure of water vapour content of the ambient air as a percentage of the air’s capacity to absorb water vapour. Relative humidity is a factor dependent upon air temperature. Several health problems can result from the large deviation of the values of relative humidity from the limits appropriate for occupants
- d. Air movement may be generated by natural convection, air leakage, infiltration, fans and the movement of occupants. Air movement increases the convective and evaporative heat losses from the body, which may cause discomfort.
- e. The quality of the indoor air affects human comfort through many ways, based on the contaminants included within it. Contaminants range from toxic particles such as carbon monoxide to nuisance particles such as large dust particles. There are a big variety of air contaminants, where, each kind has varying impacts on the human body.

The definition of the indoor environment and to control it in order to achieve the thermal comfort in buildings is difficult to be created. Since the thermal comfort depends on many factors, many studies have been carried out to investigate the various factors, and have proposed some comfort indicators. ASHRAE in its publication about indoor conditions which

can achieve thermal comfort for occupants has defined a comfort zone for winter and summer seasons. This definition of comfort zone is complex but can be simplified through some approximation ways to be a zone depending only on relative humidity and temperature as shown in Figure 1.

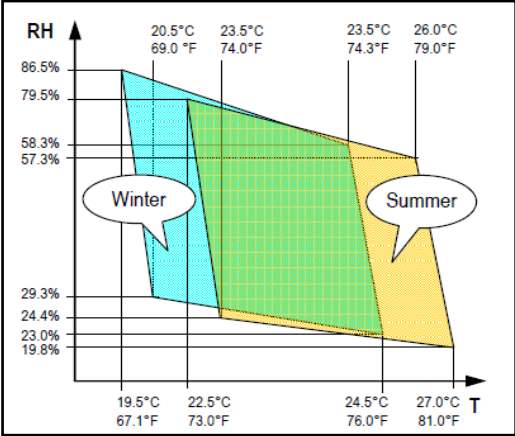

Figure 1: Relative humidity/temperature diagram based on comfort zone according to ASHRAE 55-1992 [6]

2.2 Indoor air quality

Toxic substances emitted from building materials and equipment in enclosed spaces, or gases resulted from human activities at home, such as the combustion of fuel when cooking or heating, all these processes may lead to a wide range of health problems and may be fatal in some cases.

Workers and students spend long time at work and school. Hence, maintaining appropriate quality of indoor air in schools and the workplace is a top priority. Outdoor air which must be used to dilute indoor air pollutants and remove contaminants included within it with moisture from the buildings is a major issue to achieve the required quality of indoor air.

Carbon dioxide, CO₂, is a natural component. The amount of CO₂ included within air sample is expressed as parts per million, ppm. CO₂ levels in the outdoor air is usually around 400 ppm [7], where, these levels depend on local conditions, such as vehicular traffic, industrial facilities in the region and other sources of pollution and combustion, and also depend on the climatic conditions such as wind and temperature in the local area. However, outdoor CO₂ levels could be higher near areas of traffic congestion vehicle traffic, industrial areas, where, there are sources of combustion.

Breathing produces carbon dioxide. Breathing for average adult contains about 35,000 to 50,000 ppm of CO₂ [8].

Current ventilation guidelines, such as done by ASHRAE, recommend that indoor CO₂ concentration not exceed the outdoor concentration by more than about 650 ppm [9]. Outdoor CO₂ concentration has significant impacts on the indoor concentration. Hence, it is important to measure outdoor CO₂ levels to deal with indoor concentrations. The concentration of CO₂ in closed spaces indicates whether the exchange of air in the building is appropriate or not for the occupants, in other words, refers to whether the optimal quantity of outside air is mixed with the air used in the building.

Indoor CO₂ concentration is related to the size of occupancy (number of people indoor), as well as the ventilation rate used and the CO₂ concentration outdoor. Because CO₂ is

generated continuously from occupants, it may accumulate if ventilation rate is not set well so that remove contaminants.

Epidemiological research has found that indoor CO₂ concentration is an acceptable indicator to predict human health and performance. Many studies have found that higher CO₂ concentrations in schools are associated with increased student absence [10]. Some studies have found that poorer student performance is associated with increased CO₂ in classrooms [11]. Some searches have confirmed that students performed their tasks at school less effectively when CO₂ concentration was higher [12]. Symptoms of carbon dioxide are shown in Figure 2.

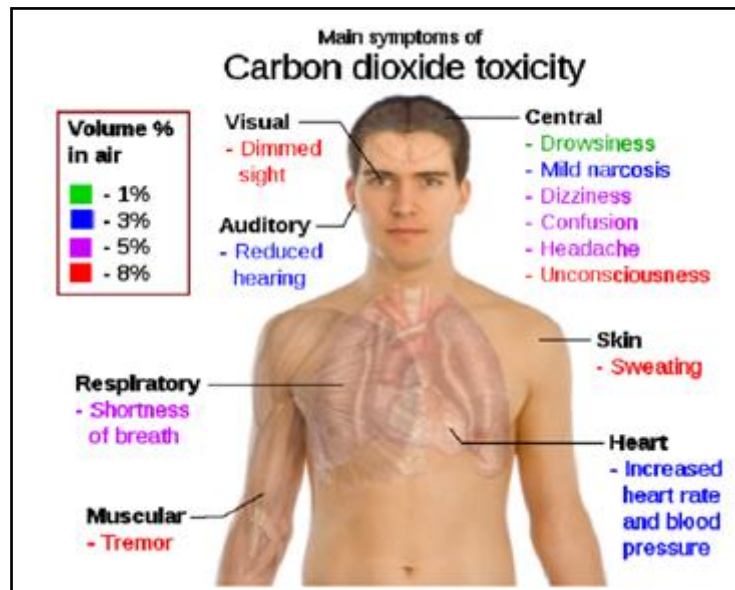

Figure 2: Main symptoms of Carbon dioxide toxicity [13]

[14] The current ventilation standards have recommended that the minimum fresh air rate should be 8 litres/s per person inside schools [15], but this ventilation rate should be applied for normal size of occupancy. Hence, sometime there is no need to use this rate at all times when the occupancy level drops.

Recent studies show that CO₂ concentration in the classroom, in many cases exceed the allowable limits, where, ventilation is often less than the required minimum of 3 L/s per person [16]. Studies indicate a close relationship between indoor air quality and the health of students and their performance. Anyway, the indoor environment and its impact on the health and comfort of occupants are not easy to define.

2.3 Humidity in building

Relative humidity is a measure refers to the water vapour in the gaseous mixture consisting of water and air. It is expressed as the ratio between the amount of water present in the air at a given temperature to the maximum amount that can be present in the air at that temperature.

Maintain the relative humidity within a range comfortable for occupants is an important factor in creating a healthy indoor environment, where, the high relative humidity indoor can lead to mould growth and spread of dust mites. Relative humidity if is high or low can be

a fertile environment for the growth of bacteria and viruses, as well as causing increased symptoms of asthma and allergic rhinitis.

Maintain the relative humidity in the range of 40-60 % is the ideal area for occupants [17]. Traditional buildings deal with moisture in the air through the control of ventilation and moisture management. Any changes to the heating or ventilation strategy in a building can affect the ability of the building to deal with the humidity, and this is critical.

In physics, moisture is defined as "water that is physically bound in the pores of a material that is able to evaporate at high temperatures" [18]. Study the exchange of moisture between the building envelope and room air deals with the transfer of moisture due to the difference in water vapour pressure on the outer surface and inner sides of the building.

Humans have difficulties to feel changes in relative humidity (RH), due to the lack of sensory receptors to moisture [19]. The concept of "dry air" is associated with the irritation of the mucous membrane of the eyes (such as dry eye) and upper airways (sensory irritation) [20], which is an major issue in the classic "sick building syndrome" in non-industrialized buildings [21]. Studies show that low RH (i.e. 10%) has very slight or no influence on the development of dry mucous membranes in the eyes and airways in a consistent manner [22]. In addition, it has been shown that high RH has a detrimental effect on the quality of indoor air [23]. This means that the quality of indoor air is seen as a "cool and dry" in office environments [24]. Hence the "dry air" has become a major issue in epidemiological studies of indoor environments. The balance of humidity in the room is affected by ventilation, air infiltration, and moisture gains. Apart from other factors, such as air temperature and air velocity, and interior comfort, the air quality is also affected by the relative humidity in the building. Furthermore, it is possible to determine the presence of condensation, mould growth, and the degradation of building materials due to moisture in the indoor. When the moisture flows through building materials, condensation may occur in non-heated areas of the building, or in areas where ventilation is reduced uncontrolled.

Water enters buildings either as a liquid or water vapour, as shown in Figure 3. Some of water in bathrooms, kitchens and laundries evaporates, and joins the water vapour exhaled by building occupants during breathing. Water vapour also moves through the building as part of the air that is being presented mechanically, or through holes and cracks in the building.

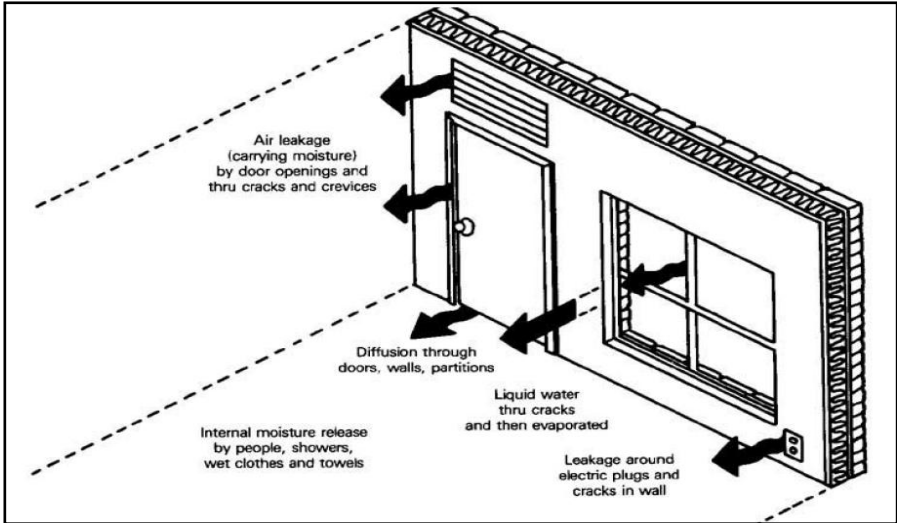

Figure 3: Moisture gain in a Building [25]

Relative humidity and temperatures often change within the building, while the actual mass of water vapour present in the air water vapour mixture (Absolute humidity) in indoor air can usually be assumed to be uniform. Therefore, if one side of the room is warm, and other side is cold, the cold side of the room has a higher RH than the warm side. Where, condensation occurs, if the relative humidity at the surface up to 100 %. This is important to understand why mould grows on one side, where, it is likely that the wall surface is cooler than the air in the room, because there is a space or isolation, or because of the wind blowing through the cracks in the outer part of the building.

2.4 Heat transfer in building

Heat transfer could take place basically through one of these forms: conduction, convection, and radiation.

1. Conduction

Conduction is a type of heat transfer which occurs when there is a temperature gradient through the body, where, the energy is usually transferred from a high temperature part to low temperature part. Higher temperatures are associated with higher molecular energies, where, they collide with less energetic molecules, so that transfer of energy occurs. The heat transfer rate by conduction can be expressed by the relation [26]:

$$\dot{Q} = -kA \frac{\partial T}{\partial x} \quad (1)$$

Where:

\dot{Q} [W]: heat transfer rate.

T [K]: temperature.

x [m]: distance.

k [W/m.K]: thermal conductivity of the material.

A [m²]: cross-sectional area of heat path.

Under the steady state conditions the temperature distribution is linear, and the temperature gradient may be expressed by the relation [26]:

$$\frac{dT}{dx} = \frac{T_2 - T_1}{l} \quad (2)$$

Where:

l [m]: thickness of heat path.

T_1 [K]: first temperature.

T_2 [K]: second temperature.

Then, heat flow can be calculated as follows [26]:

$$\dot{Q} = \frac{kA}{l} (T_1 - T_2) \quad (3)$$

In buildings, conduction occurs through solid walls that are not in thermal equilibrium.

2. Convection

Convection heat transfer occurs when a liquid flows touching a warm body. Fluid adjacent to the body constitutes so-called boundary layer, where the speed of the liquid on the surface is equal to zero. So, at this point, heat is transferred by conduction only. Fluid moves and carries the heat away. Temperature gradient on the surface of the body depends on the rate of carrying the heat away.

Newton's law of cooling expresses the overall effect of convection, is given by the relation [27]:

$$\dot{Q} = hA(T_s - T_\infty) \quad (4)$$

Where:

\dot{Q} [W]: heat transfer rate.

A [m²]: surface area.

T_s [K]: wall (surface) temperature.

T_∞ [K]: fluid temperature.

h [W/m².K]: convection heat transfer coefficient.

3. Radiation

All bodies emit energy due to electromagnetic radiation. Electromagnetic radiation as a result of a temperature difference is called thermal radiation. Where, blackbody (ideal thermal radiator) emits energy at a rate proportional to the fourth power of its absolute temperature and its surface area. Thus [26]:

$$E_o = \sigma AT^4 \quad (5)$$

Where:

E_o [W]: emitted energy rate.

σ : proportionality constant (Stefan – Boltzmann constant) $\sigma = 5.669 \times 10^{-8} \text{ W/m}^2 \cdot \text{K}^4$

Equation (5) is called the Stefan-Boltzmann law of thermal radiation and it applies only to the blackbodies.

For surfaces which are not behaving as a blackbody, a factor known as emissivity ϵ is used, is a measure of how efficiently a surface emits energy relative to a blackbody. Radiation heat transfer occurring between a surface at temperature T_1 completely enclosed by a much larger surface maintained at temperature T_2 can be calculated by the relation [26]:

$$\dot{Q}_{12} = \epsilon_1 \sigma A_1 (T_1^4 - T_2^4) \quad (6)$$

Where:

ϵ_1 [-]: emissivity of surface at temperature T_1 . Where: $0 \leq \epsilon \leq 1$.

A_1 [m²]: surface area.

With regard to buildings, whenever there is a temperature difference between the conditioned indoor space of a building and outdoor air, heat transfer takes place through the building structure (walls, roof, floor, etc), as shown in Figure 4. This is known as heat gains or losses, based on if heat transfer is to the building or from the building. Heat transfer through building includes sensible heat transfer through all the structural elements of a building. Exact analysis of heat transfer through building structures is very complex, due to the following facts:

- Complex structure of the building envelops, such as walls, roofs, etc. These parts consist of a wide variety of materials with different thermal properties.
- Continuously changing in outdoor conditions due to variation in climate conditions, such as solar radiation, outdoor temperature, wind velocity and direction, etc.
- Continuously changing in indoor temperature due to variations in indoor thermal loads.

For cooling and heating load calculations, the indoor conditions are usually assumed to be constant to simplify calculations. However, the changing in outdoor conditions due to solar radiation and outdoor temperature must be taken into account in the analysis in order to calculate the appropriate heating and cooling loads.

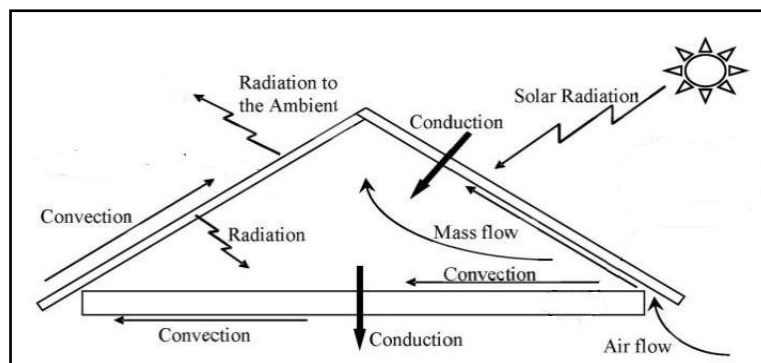

Figure 4: Schematic of the heat transfer mechanisms in the house roof [28]

The rate of heat exchange (\dot{Q}) through some parts such as roof, wall or floor under steady state can be calculated as follows [29]:

$$\dot{Q} = AU\Delta T \quad (7)$$

Where:

\dot{Q} [W]: heat transfer rate.

A [m^2]: surface area.

U [$W/m^2.K$]: the overall heat transfer coefficient.

ΔT [K]: temperature difference between inside and outside air.

U is calculated by the relation [29]:

$$U = \frac{1}{R_{total}} \quad (8)$$

Where:

R_{total} [$m^2.K/W$]: total thermal resistance, it can be calculated as follows [30]:

$$R_{total} = \frac{1}{h_{inside}} + \left(\sum_{j=1}^m l_j / k_j \right) + \frac{1}{h_{outside}} \quad (9)$$

Where:

h_{inside} , $h_{outside}$ [$W/m^2.K$]: inside and outside heat transfer coefficients respectively.

l_j [m]: thickness of the j_{th} layer.

k_j [$W/m.K$]: thermal conductivity of j_{th} material.

U [$W/m^2.K$]: the total amount of heat transmitted from outdoor air to indoor air through a wall or roof per unit area per unit time.

If the surface is also exposed to solar radiation, then [31]:

$$\Delta T = T_{so} - T_{indoor} \quad (10)$$

Where:

T_{indoor} [K]: indoor temperature.

T_{so} [K]: sol-air temperature.

To calculate the effect of solar radiation, sol-air temperature is used, which is an equivalent outdoor temperature combines the effects of convection and radiation. Solar radiation on walls warms the surfaces and affects the rate of conduction heat transfer through the wall. It is calculated using the relation [31]:

$$T_{so} = T_{outdoor} + \frac{\alpha.I}{h_{outside}} \quad (11)$$

Where:

$T_{outdoor}$ [K]: outdoor air temperature.

I [W/m^2]: the total solar heat flux on the wall.

α [-]: absorptance of surface for solar radiation.

3 OUTDOOR CLIMATE DATA

The weather in any area represents a state of the environment in the atmosphere within a short period of time. Weather over several years is usually known as climate. Analysis of the climate in a particular area can help to determine the periods during which a person is in uncomfortable situation, and also helps in the identification of more important climatic parameters, where, this information can help to build the buildings in the form capable of dealing with climate change. In addition to that discomfort and the demand for energy needed for mechanical systems can be significantly reduced by using an appropriate control of the climatic effects.

Weather and climate is characterized by some of the variables known as climatic factors. They are solar radiation, outdoor temperature and air humidity.

Solar radiation:

Solar radiation is the radiant energy generated from the sun. It is the intensity of sunrays incident per unit time per unit area, and is usually calculated in Watts per square metre W/m^2 . The radiation incident on a surface continuously varies depending on season, time of day and atmospheric conditions, geographic location (latitude and longitude of the region), orientation. Solar radiation is so important variable, because it determines whether the region experiences high or cold temperatures.

Outdoor temperature:

The outdoor temperature in a shaded place is known as the ambient temperature, it is generally calculated in degree Celsius $^{\circ}C$. Outdoor temperature depends on wind and local factors such as shading, presence of water, etc. Where, when the wind speed is low, local factors strongly influence on temperature of air close to the ground. On the other hand, when higher wind speeds, local factors less influence on outdoor temperature.

Air humidity:

Air humidity represents the amount of moisture within the air, and is usually described in terms of 'relative humidity', which is normally expressed as a percentage. Relative humidity continuously varies, tending to be higher when the air temperature is lower, and to be lower as the air temperature rises. The decrease in the relative humidity tends to be the largest in summer.

3.1 Meteorological station TUBO

In the frame of EUREF permanent network (Regional Reference Frame Sub-Commission for Europe) [32], the meteorological station is identified by four-character code TUBO [33]. The CERGOP (Central European Reference Geodynamic Project) Campaigns were performed in 1999 and 2001 years at this station for geodynamical investigation in the states of central Europe. The measurements on the station of the EUREF permanent network with code TUBO are used (together with measurements on further stations) [34]:

- Study the movements of Euro-Asian plate and for study of the intraplate movements.
- Definition of ETRS (European Terrestrial Reference System) in the Czech Republic.
- Monitoring the state and changes in some atmospheric parameters, and as the reference station's data for GPS surveying.

Description of the data flow [34], as shown in Figure 5: “Trimble receiver is connected by the serial link to the personal computer, where the measured data are sent continuously. Some programs run in the computer: primary program is the Trimble Reference Station software (TRS), which saves the measured data to the disk in the RINEX format and TRS runs special program after finish saving data to certain file. This special program checks the GPS data (in some cases it also merges the data) and it converts the data by another programs (CHECKRNX, LINKNAV, RNX2CRX, METRINTR) to the CompactRINEX format, attaches the meteorological data to the GPS data and prepares the data for sending.

Detailed information about meteorological data is shown on the page about meteorological data at the TUBO station.

The program for moving or delete the sent data and for management of primary data archive is running at half an every hour. There are some other programs running on the computer. They are: a program for recording the meteorological sensors, a program for communication with computer network and a program for setting the computer clock by accurate time servers.

The proper transmission is realized by operational centre GOP (only in Czech). The GPS NAVSTAR data files are sent to the OLG data centre in Graz. The data in files with 5-minutes length are sent to the experimental data centre for DGPS.

Availability of data from permanent GPS station TUBO in Brno is exactly described at page about TUBO station hosted by VUT (<http://tubo.fce.vutbr.cz/new/>.)”

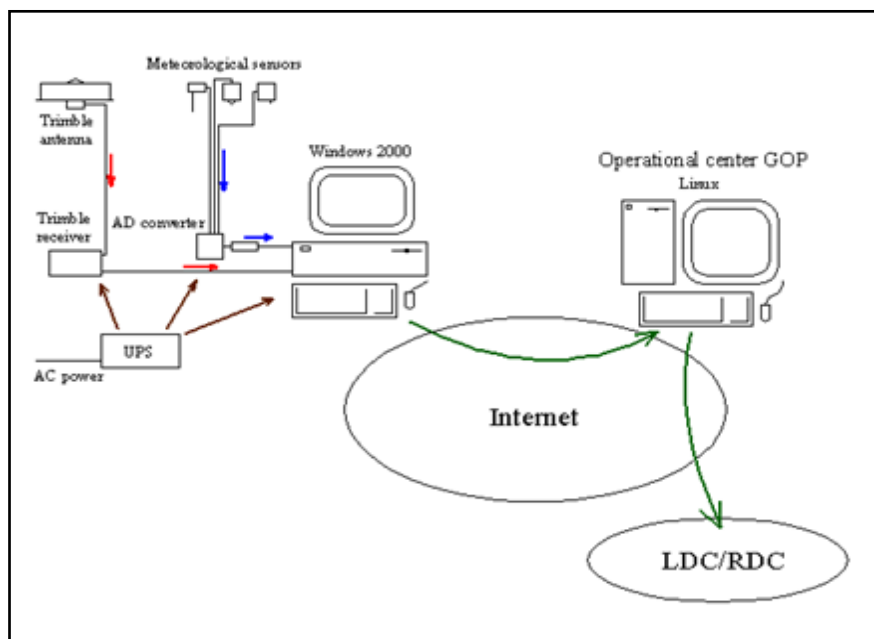

Figure 5: Data flow from TUBO station [34]

In this work, climate data from the station TUBO have been recorded for the period from September 2012 until August 2013. Where, the model has been applied for cold days, hot days, and mild days.

Table 1 shows the recorded data (average temperature, minimum temperature and maximum temperature respectively). Where, the values with red colour represent the cold days selected. Blue values represent the mild days, and green values represent hot days.

Table 1: Meteorological data recorded by TUBO station from September 2012 to August 2013

Month Day	September 2012	October 2012	November 2012	December 2012	January 2013	February 2013	March 2013	April 2013	May 2013	June 2013	July 2013	August 2013
1	15,6 13,3 17,6	15,9 10,2 21,5	6,2 3,8 7,5	0,5 -3,3 4,6	-0,7 -3,3 -0,2	5,2 2,9 8,6	2,3 1,1 3,3	-0,4 -3,6 3,2	14,6 11,3 19,9	11,9 7,0 17,0	3,5 0,0 0,1	23,8 16,2 30,8
2	17,9 13,6 23,7	13,6 9,3 17,2	6,1 4,6 8,4	-0,6 -2,9 1,1	-1,1 -2,1 0,3	3,2 1,6 5,0	1,8 -2,2 6,3	-2,3 -3,2 52,3	15,1 10,7 18,5	13,5 10,8 19,6	1,6 0,0 11,7	26,1 16,4 35,0
3	19,1 14,3 25,1	14,0 7,1 22,2	6,3 3,7 8,5	0,3 -2,4 2,6	0,9 -3,9 5,6	0,7 -1,0 2,4	0,8 -4,3 5,3	0,7 0,1 1,7	12,6 10,0 15,3	10,3 9,3 11,7	0,0 0,0 0,0	28,2 17,9 37,4
4	19,8 15,3 24,9	14,1 7,3 20,7	9,5 6,4 11,6	-0,7 -2,5 0,3	7,2 5,5 8,3	2,0 0,1 3,4	2,5 -1,9 7,6	2,2 -0,2 5,7	14,9 9,9 20,0	13,7 10,6 17,7	12,6 0,0 27,5	25,7 18,2 34,0
5	19,8 14,2 25,9	12,7 5,8 19,1	7,1 2,7 11,7	-1,0 -3,7 2,0	6,3 2,0 8,8	3,3 1,2 5,6	5,0 -0,4 10,4	1,8 0,8 3,0	15,2 12,3 20,6	13,0 11,4 15,1	21,6 17,8 26,3	23,6 17,1 31,2
6	15,8 9,4 19,3	17,8 9,6 25,3	4,4 0,9 8,2	-2,3 -4,9 1,3	3,7 1,8 6,3	0,6 -2,0 3,15	8,4 3,6 14,8	3,0 1,5 4,6	17,2 12,8 22,6	15,5 11,4 20,5	22,0 18,3 25,3	27,4 17,6 34,9
7	16,0 7,2 23,7	11,8 7,1 18,2	5,8 1,3 8,3	-6,2 -9,1 -2,9	0,8 -2,4 5,8	-0,2 -2,4 3,8	10,4 8,1 13,2	2,6 0,6 4,6	17,5 14,6 21,5	17,4 12,8 22,6	21,9 17,3 25,9	28,0 21,1 34,9
8	18,9 11,6 25,7	7,7 2,7 12,5	7,7 4,6 10,8	-6,3 -9,2 -2,1	-1,4 -3,1 0,0	-1,8 -4,3 2,0	8,6 5,2 11,3	4,5 -1,6 8,8	18,1 11,9 22,8	19,4 13,0 26,4	21,0 15,6 25,8	30,8 25,0 38,5
9	19,8 12,8 27,1	6,9 1,3 12,8	7,3 4,0 11,1	-6,9 -12,0 -2,1	0,4 -1,8 3,6	-2,3 -5,5 0,3	5,8 4,0 7,7	7,2 4,5 11,0	20,0 12,9 25,8	21,5 13,1 27,7	16,5 15,0 21,0	23,8 17,3 31,2
10	21,7 13,4 29,1	7,4 2,4 12,5	6,3 3,9 9,8	-1,2 -3,7 0,4	2,0 -0,7 5,3	-2,4 -2,9 -0,8	5,7 3,7 7,7	6,9 3,4 11,8	18,0 13,0 24,9	18,7 14,9 24,5		18,7 14,4 23,8
11	22,2 12,9 29,8	6,9 1,5 12,8	8,5 6,2 11,3	-2,4 -4,5 -0,4	-0,7 -3,8 2,6	-2,6 -3,8 -1,7	4,1 -0,5 7,1	10,0 1,3 17	12,0 10,4 13,2	15,4 10,7 19,1	16,6 14,3 19,9	20,6 13,1 27,1
12	16,5 9,7 20,9	8,0 2,4 10,5	8,6 7,3 10,3	-5,0 -6,3 -3,0	-4,3 -6,6 -1,3	-1,7 -3,8 -0,1	0,7 -1,2 3,8	11,3 6,8 15,2	11,8 9,4 16,5	16,8 9,4 22,8	17,6 13,8 21,7	20,9 13,9 26,8

13	9,6 8,9 11,6	10,4 7,1 14,7	7,8 3,7 10,2	-5,2 -6,1 -2,8	-4,5 -7,6 -2,3	-0,7 -1,4 0,2	0,8 -1,9 4,1	9,9 4,1 15,3	11,2 6,7 17,2	19,6 10,3 27,0	19,2 13,8 24,6	20,3 15,6 24,3
14		10,4 6,0 14,3	2,8 -1,8 7,6	-2,3 -6,0 0,8	-2,9 -3,9 -2,0	-0,3 -1,4 1,0	-2,8 -4,1 -1,5	10,8 2,9 17,4	13,0 5,6 20,4	18,2 11,7 22,9	20,3 15,0 25,3	17,9 12,4 23,1
15		12,7 8,7 18,4	3,6 -1,8 6,7	1,6 0,7 2,6	-3,2 -6,7 0,4	0,6 -0,5 2,1	-2,5 -4,6 0,6	12,2 3,4 19,2	16,4 7,3 22,1	21,0 14,8 26,9	18,7 13,5 23,0	17,0 9,6 24,7
16		7,3 4,5 8,8	3,9 0,0 7,0	0,9 0,5 1,1		0,9 -1,3 4,3	-2,5 -6,3 2,4	14,0 6,1 20,0	19,1 13,8 23,6	22,1 16,9 27,7	19,9 12,0 26,9	18,7 9,9 26,5
17		8,4 3,2 14,0	6,3 5,8 6,8	1,9 1,6 2,2		0,6 -1,8 2,6	-1,0 -5 3,4	16,1 8,5 22,5	18,3 15,2 22,2	24,8 16,1 31,4	22,8 13,7 30,0	20,9 11,1 29,5
18		12,5 6,7 16,0	6,0 5,3 6,8	1,7 1,3 2,2		0,4 -0,5 1,8	-0,6 -1,7 1,7	17,7 8,6 24,4	17,6 13,3 22,8	27,1 19,0 33,2	23,1 17,3 28,8	24,0 14,3 32,0
19		11,5 6,0 18,6	6,9 5,0 9,9	2,5 1,0 3,9		0,4 -0,3 1,1	3,7 1,0 5,5	13,0 9,2 16,6	19,6 11,7 25,9	27,5 20,1 33,5	23,8 16,8 30,5	22,2 16,8 30,2
20		10,6 5,1 18,9	7,5 2,0 10,9	0,2 -4,4 2,5	-2,0 -2,4 -1,8	-1,0 -4,4 1,8	4,2 -2,0 10,8	10,8 8,7 14,2	15,7 10,4 20,4	28,9 23,9 34,6	21,6 16,5 26,6	17,4 14,7 20,0
21		10,6 6,6 16,7	6,3 2,1 8,6	-2,8 -5,2 -1,6	-1,3 -2,4 -0,5	-3,6 -6,0 -0,8	2,5 -0,6 7,0	14,0 8,3 19,7	14,2 9,0 20,4	25,4 20,5 30,5	21,3 14,1 28,5	17,1 12,3 22,0
22		11,6 7,0 16,6	7,3 6,2 8,5	-3,0 -3,4 -2,0	-2,9 -5,3 -1,6	-3,6 -6,3 -1,7	-0,3 -2,7 1,5	15,1 6,8 22,4	13,1 7,7 19,4	22,3 17,7 26,8	22,9 13,6 30,8	16,8 10,6 22,0
23		9,4 7,0 11,7	6,4 5,8 6,9	-1,3 -2,5 -0,4	4,5 -5,6 -3,6	-0,6 -2,4 0,7	-4,0 -8,2 -1,0	15,5 8,2 21,7	9,5 5,9 12,7	15,2 0,0 28,2	24,1 15,4 31,6	18,4 11,7 24,0
24	18,6 15,5 21,9	10,4 7,3 14,1	6,2 5,3 7,6	-0,2 -0,5 0,3	-2,2 -3,8 0,8	2,2 0,3 3,1	-4,2 -9,1 0,1	15,8 8,1 22,7	10,4 6,2 13,9	8,5 0,0 13,8	24,0 14,6 32,3	18,6 15,3 22,9
25	17,6 13,3 22,5	9,1 7,8 9,8	7,5 6,4 8,2	0,7 -0,4 1,5	-5,0 -6,0 -2,7	3,3 2,3 4,0	-3,8 -6,4 -1,8	17,7 9,0 25,2	9,8 7,0 13,3	12,5 11,7 13,5	23,0 18,9 28,6	16,5 14,7 18,8
26	19,0 12,3 24,6	6,6 4,0 8,6	7,0 6,4 7,8	0,2 -1,3 1,0	-6,8 -9,9 -3,9	3,8 1,9 6,9	-3,1 -4,6 -1,1	19,7 9,6 27,2	9,9 5 14,2	11,9 9,9 14,2	25,0 17,0 32,2	14,7 13,9 15,5

27	16,7 13,6 18,8	3,0 0,1 5,0	8,5 7,3 9,3	2,2 -1,8 5,5	-7,4 -9,7 -5,5	3,5 1,8 5,8	-2,1 -5,1 0,5	19,5 14,3 25,4	9,4 6,7 11,4	13,1 8,1 17,3	27,6 18,4 35,0	15,2 13,8 17,4
28	14,9 8,8 20,5	1,4 -0,9 3,9	9,1 5,6 12,7	0,9 -4,8 4,0	-3,1 -5,5 -0,6	4,1 0,5 8,0	0,4 -1,4 2,3	13,7 9,0 17,1	13,0 7,2 18,8	15,1 10,1 20,2	29,8 19,7 36,6	16,2 13,1 19,8
29	13,5 7,1 19,0	1,2 -0,3 3,1	3,8 3,0 4,8	-2,9 -6,7 0,3	0,6 -2,4 3,9		1,8 0,2 3,5	14,5 7,4 20,1	15,4 11,3 20,6	0,7 -0,1 11,0	28,3 19,9 35,4	17,8 12,9 23,2
30	14,8 11,1 20,0	2,1 -2,0 5,6	2,4 -0,2 3,5	-1,1 -2,7 0,5	4,6 2,2 7,3		3,1 0,1 6,0	17,6 10,6 24,9	11,9 10,2 12,8	0,0 0,0 10,4	21,0 16,5 26,3	17,6 11,0 25,0
31		4,8 2,6 7,4		-2,0 -5,2 2,5	6,9 4,6 8,9		-0,3 -1,3 0,8		10,5 7,8 14,4		21,8 15,1 26,7	18,5 13,1 25,7

3.2 Processing of weather data by using MATLAB/SIMULINK software

SIMULINK is a program that runs as a companion to MATLAB. These programs are developed and marketed by the MathWorks, Inc [35]. SIMULINK and MATLAB form a package that serves as a tool for modelling dynamic systems. SIMULINK provides a graphical user interface (GUI) that is used in building block diagrams, performing simulations, as well as analysing results. Table 1 contains data about the outdoor temperature on each day of the simulated period. In addition to the outdoor temperature, data of relative humidity of ambient air and data of sun radiation incident on the horizontal surface can be obtained through the site TUBO. These data can be obtained as *text documents*. In order to use these data, they must be converted into a format readable in the designed model. Weather data of the selected days shown in Table 2, in addition to data of relative humidity and intensity of solar radiation have been converted to MAT files using MATLAB software as shown in Figure 6. These files represent modelling the climatic conditions of the outdoor environment.

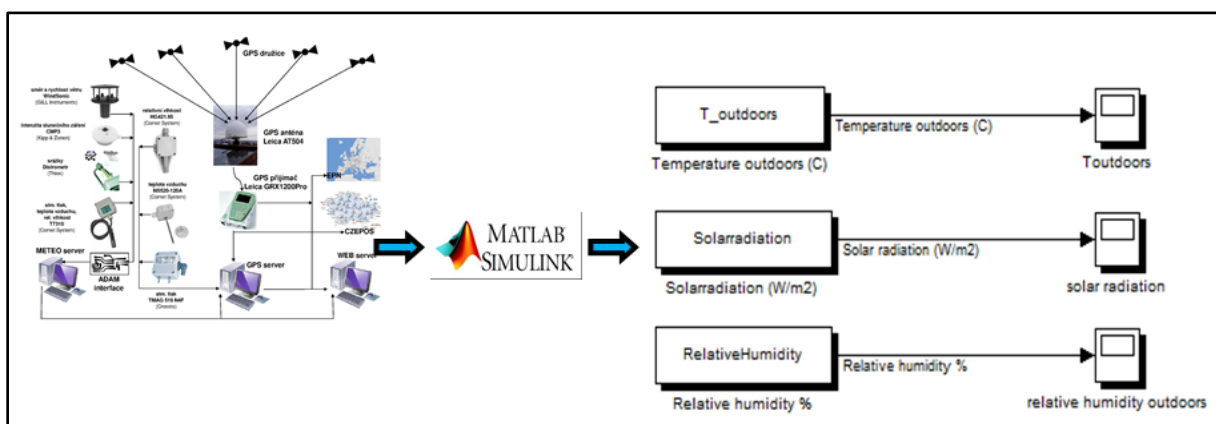
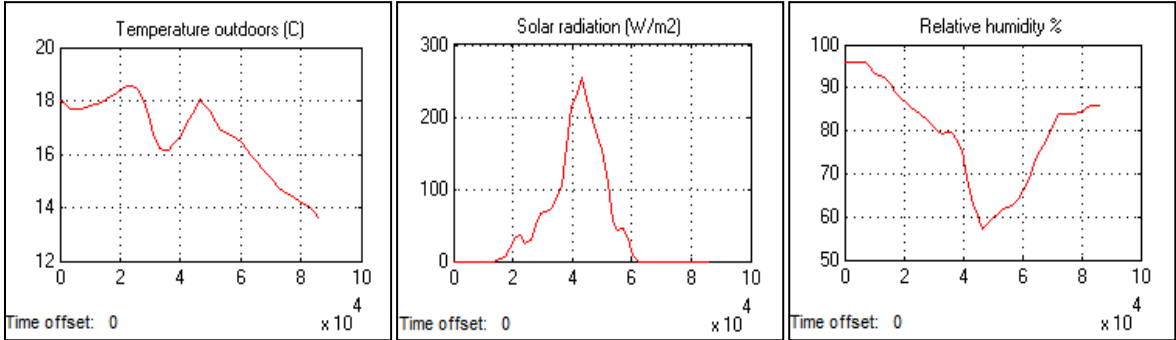

Figure 6: Conversion of weather data for the designed model by using MATLAB/SIMULINK

After converting the data into MAT files by using MATLAB/SIMULINK, it is possible to plot the data in charts. The results are shown in sub-figures contained in Figure 7. Where, all diagrams are results for the period from 0 to 86400 s, corresponding time from 0:00 am to 12:00 pm

27. 9.2012 (Mild Day)



22.10.2012 (Mild Day)

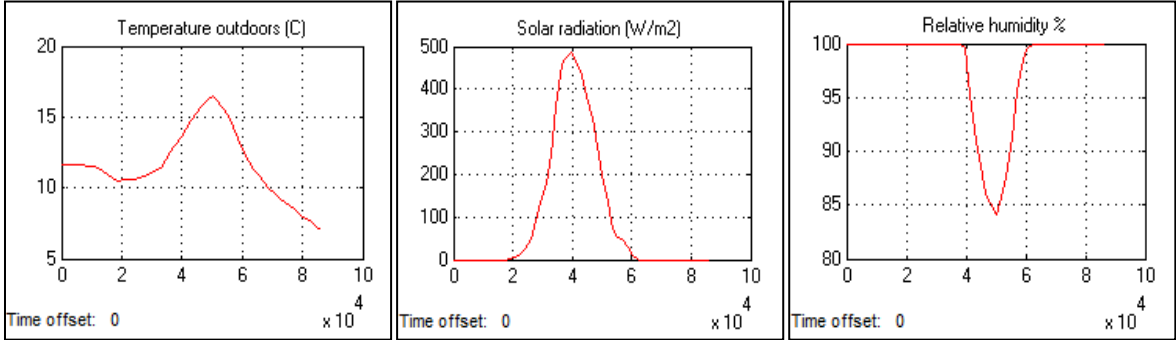

12.11.2012 (Mild Day)

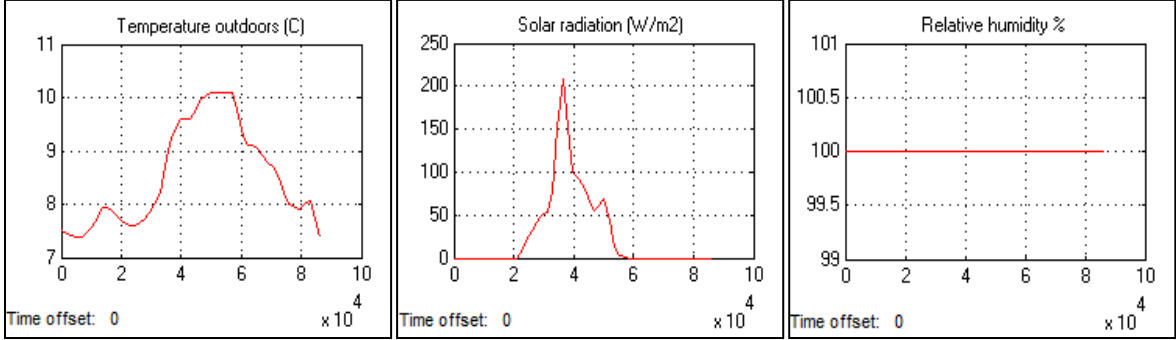

7.12.2012 (Cold Day)

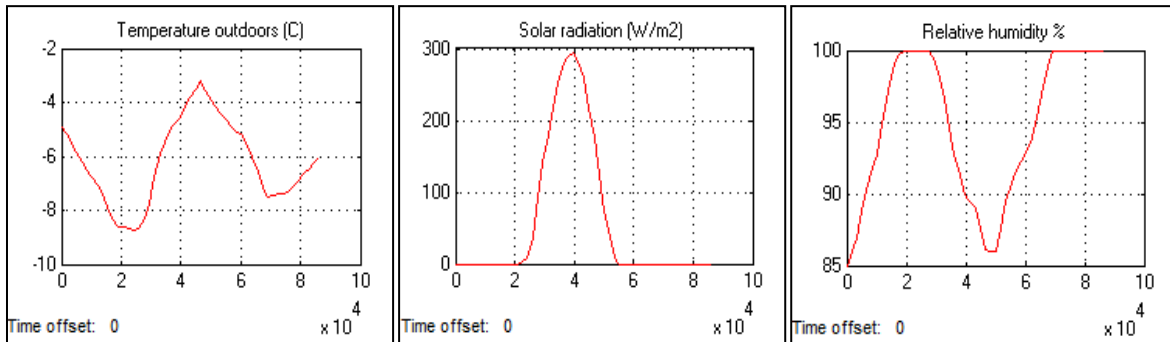

25.1.2013 (Cold Day)

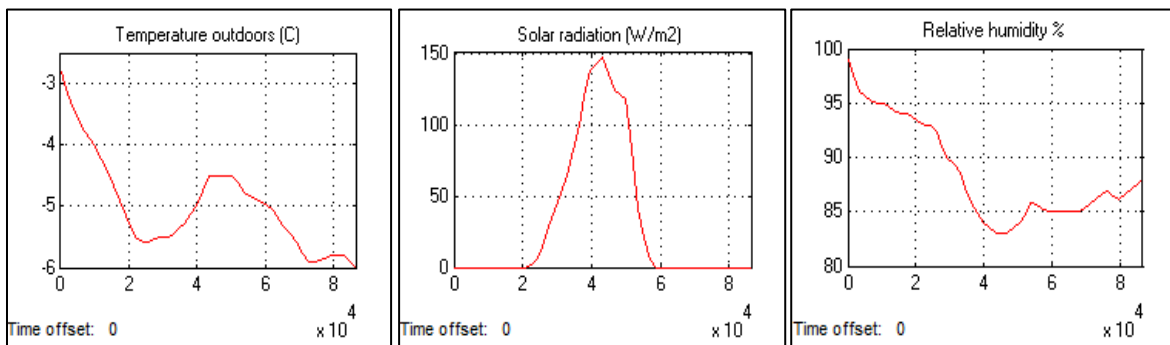

21.2.2013 (Cold Day)

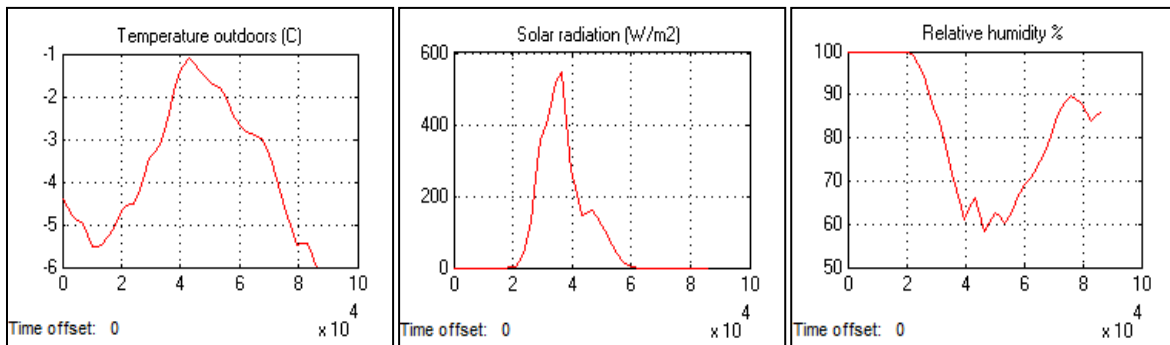

8.3.2013 (Mild Day)

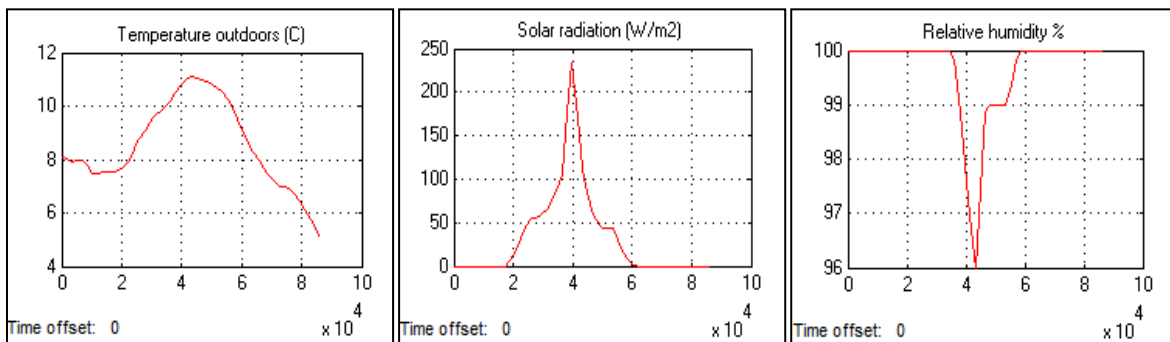

23.4.2013 (Mild Day)

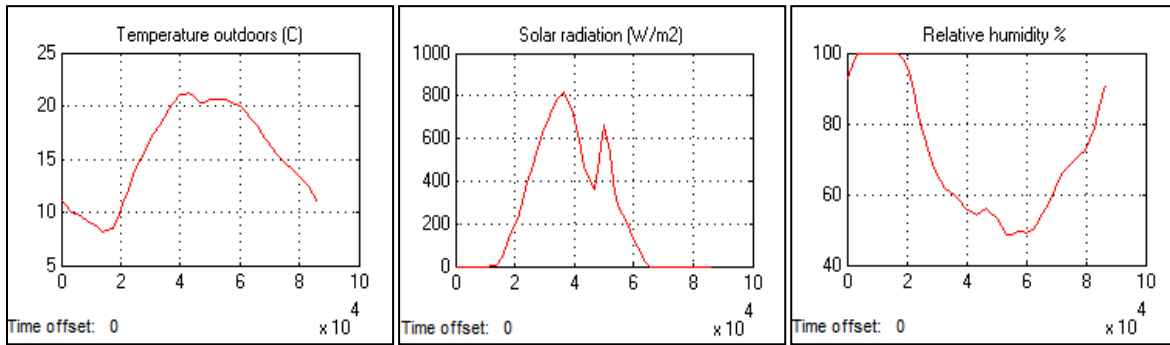

7.5.2013 (Mild Day)

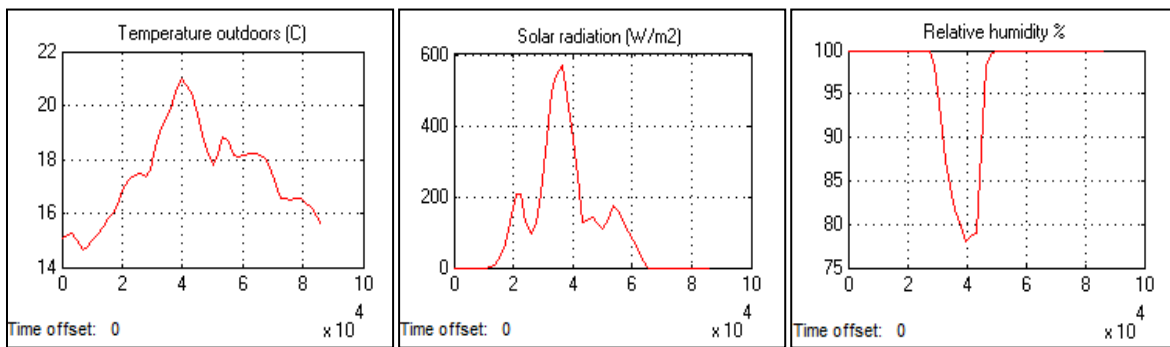

20.6.2013 (Hot Day)

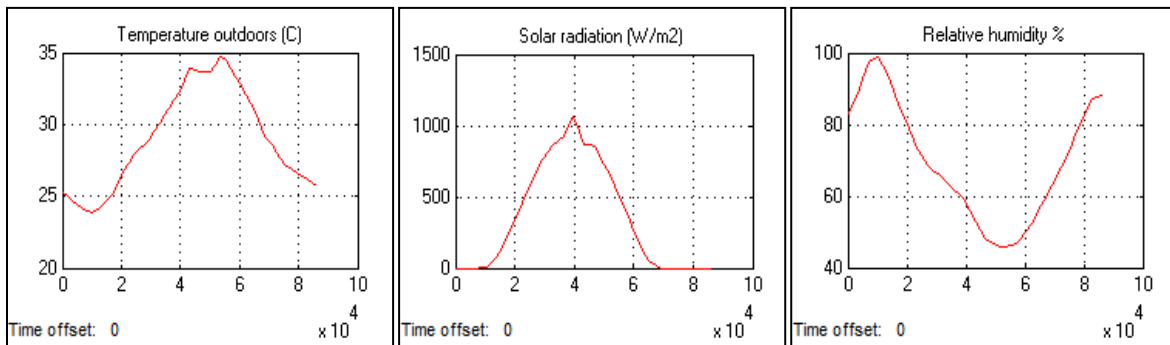

19.7.2013 (Hot Day)

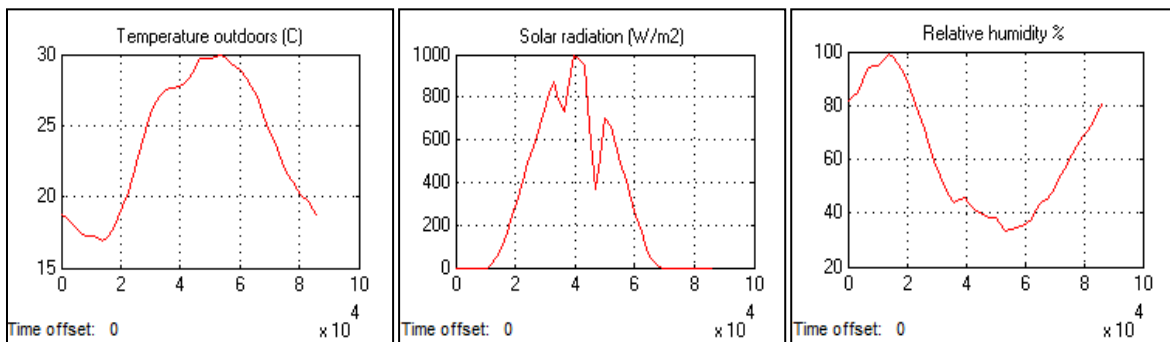

8.8.2013 (Hot Day)

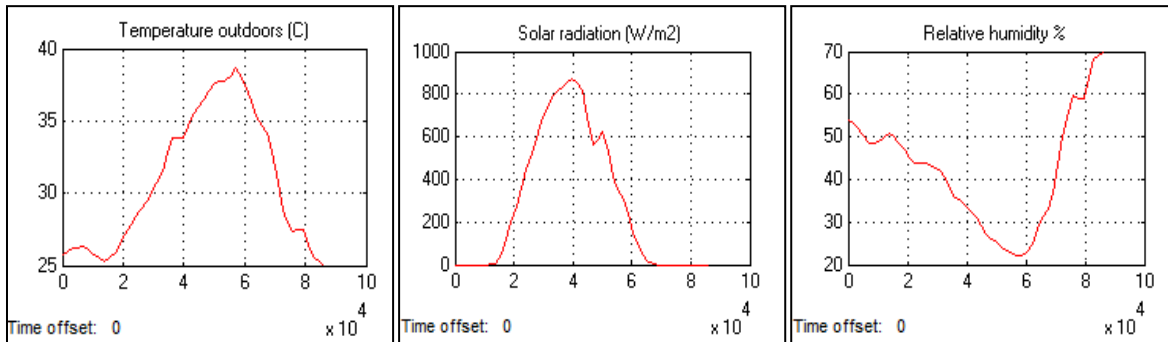

Figure 7: Meteorological data recorded by TUBO station from September 2012 to August 2013

3.3 Processing of weather data by using TRNSYS software

3.3.1 Basics and background

TRNSYS, a transient systems simulation program that has been commercially available since 1975 [36], continues to develop by the international collaboration from the United States (Thermal Energy System Specialists and the University of Wisconsin-Solar Energy Laboratory), France (Centre Scientifique et Technique du Bâtiment), and Germany (TRANSSOLAR Energietechnik).

The software package consists of a graphical front-end (TRNSYS Simulation Studio) to intuitively create a simulation, an interface for the detailed TRNSYS multi-zone building (TRNBuild/Type56), a Google SketchUp plugin for creating the multi-zone building envelope (TRNSYS3D), and a tool for manually editing the TRNSYS input files and creating stand-alone TRNSYS-based applications (TRNEdit/TRNSED) [37].

TRNSYS includes a graphical interface, a simulation engine, and a library of components that range from various building models to standard HVAC equipment to renewable energy and emerging technologies [37].

The sun has approximately a spherical shape, its diameter is about 1.39×10^6 km, and its average distance from the earth is 1.495×10^8 km as shown in Figure 8. The solar disc subtends a very small angle of 32' at any point on the earth's surface. Hence, the radiation received from the sun directly on the earth's surface can be considered parallel for all practical purposes. The energy flux resulted from the sun outside the earth's atmosphere is almost a constant value and is termed as the Solar Constant I_{sc} . It is defined as the energy received outside the atmosphere, per second, by a unit surface area normal to the direction of sun's rays at the mean sun-earth distance, is about 1367 W/m^2 . Filtering by gases in the atmosphere and by cloud and particulates means that fluxes at the earth's surface are variable and typically less than this value. Solar radiation incident on building surfaces can be broken down into three main components: direct (beam) radiation emanating from the region of the sky near to the sun's disc, diffuse radiation from the sky vault, and radiation scattered by the ground. Direct radiation is significantly modified by shading by nearby buildings and landscape features. Solar radiation enters the building through glazing and is absorbed (after repeated scattering) by internal surfaces. Part of this radiation may be lost

by being retransmitted out of the building through glazing. The effect of absorption and scattering by exterior surfaces (both opaque and transparent) is also significant.

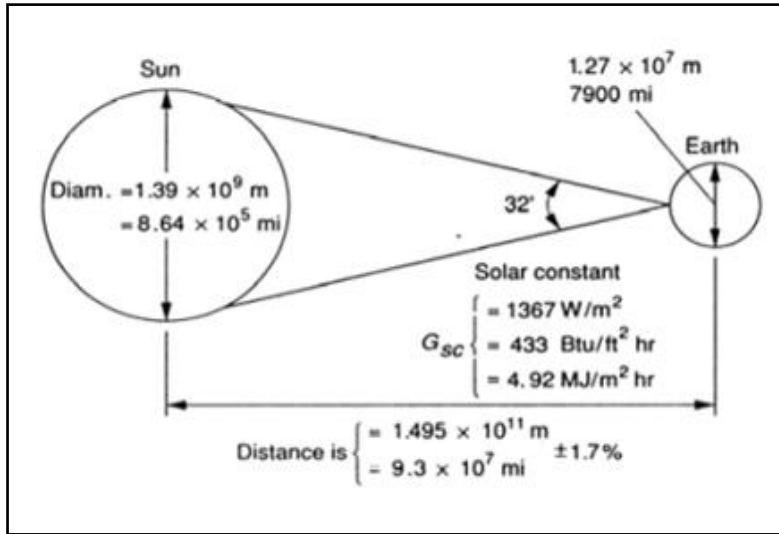

Figure 8: Sun-Earth relationships [38]

The intensity of radiation on a plane normal to sun's rays on any day is given by the relation [39]:

$$I_{ext} = I_{sc} [1.0 + 0.033 \cos(360n/365)] \quad (12)$$

Where:

I_{ext} [W/m²]: The intensity of radiation.

n is the day of the year, where: $1 \leq n \leq 365$.

Solar radiation is received on the earth's surface after undergoing various mechanisms of attenuation, reflection and scattering in the earth's atmosphere. Consequently, two types of radiation are received at the earth's surface: one that is received from the sun without change of direction, called beam radiation, and the other whose direction has been changed by scattering and reflection, called diffuse radiation. The sum of these two types is known as total or global radiation. Usually solar radiation incident on the earth's surface is measured on a horizontal surface. In order that the data reflect a true representation of the place, hourly measurements are carried out for a large number of years (typically ten years), and monthly averages of hourly radiation values over a number of years are calculated.

External surfaces of buildings receiving solar radiation are generally tilted, except for the flat roof, which is a horizontal surface. Consequently, it is required to estimate radiation on such surfaces from the data measured on a horizontal surface. The tilted surfaces receive three types of solar radiation, are beam radiation directly from the sun, diffuse radiation coming from the sky dome, and reflected radiation due to neighbouring buildings and objects. The estimation of the last component is very complicated. However, its contribution is much less compared to the first two sources.

For a surface tilted at an angle β , and with no shading, hourly incident solar radiation can be estimated as follows [40]:

$$I_T = I_g r \quad (13)$$

Where r is the global radiation tilt factor, and is given by the relation [39] [40]:

$$r = \left(I - \frac{I_d}{I_g}\right)r_b + \left(\frac{1 + \cos \beta}{2}\right)\frac{I_d}{I_g} + \rho_s \left(\frac{1 - \cos \beta}{2}\right) \quad (14)$$

$$r_b = \frac{\cos \theta}{\cos \theta_z} \quad (15)$$

$$\cos \theta = \sin \phi \cdot \sin \delta \cdot \cos \beta - \sin \delta \cdot \cos \phi \cdot \sin \beta \cdot \cos \gamma + \sin \delta \cdot \cos \phi \cdot \cos \beta \cdot \cos \omega + \cos \delta \cdot \sin \phi \cdot \sin \beta \cdot \cos \gamma \cdot \cos \omega + \cos \delta \cdot \sin \beta \cdot \sin \gamma \cdot \sin \omega \quad (16)$$

$$\cos \theta_z = \sin \phi \sin \delta + \cos \phi \cos \delta \cos \omega \quad (17)$$

Where:

I_T [W/m²]: hourly incident solar radiation.

I_g [W/m²]: mean hourly global solar radiation.

I_d [W/m²]: mean hourly diffuse solar radiation.

β [°]: slope, is the angle made by the plane surface with the horizontal.

ρ_s [-]: reflectivity of the ground surface.

r_b [-]: hourly geometric factor.

θ_z [°]: solar zenith angle.

θ [°]: incidence angle, the angle between the beam radiation on a surface and the normal to that surface.

ϕ [°]: latitude of a location, is measured as positive for the northern hemisphere.

γ [°]: surface azimuth angle, is the angle made in the horizontal plane between the line due south, and the projection of the normal to the surface on the horizontal plane, and is taken to be positive if the normal is east of south and negative if west of south.

ω [°]: hour angle, is the angular measure of time and is equivalent to 15° per hour.

δ [°]: declination angle, is defined as the angle made by the line joining the centres of the sun and the earth with its projection on the equatorial plane. It can be calculated from the following relation [40]:

$$\delta = 23.45 \sin \left[\frac{360}{365} (284 + n) \right] \quad (18)$$

Where:

n : day of the year

Sun-Earth angles are shown in Figure 9.

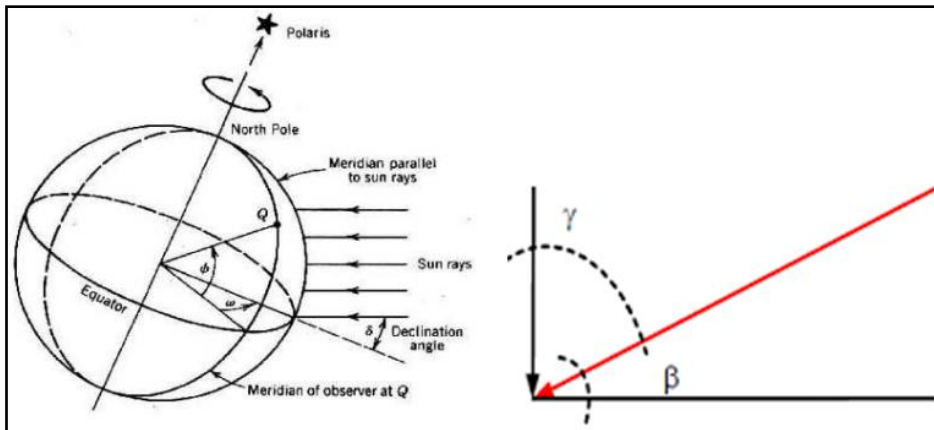

Figure 9: Sun-Earth angles [38]

3.3.2 TRNSYS model

Weather data concerning solar radiation taken from TUBO station represent the intensity of solar radiation on horizontal surfaces. But in this work, there are vertical walls with different orientations. Therefore, a model has been designed to calculate the intensity of solar radiation on each wall using TRNSYS software, as shown in Figure 10.

Where, by using total solar radiation on horizontal surface, air temperature and relative humidity, the solar radiation incident on all walls can be obtained for the given geographic location.

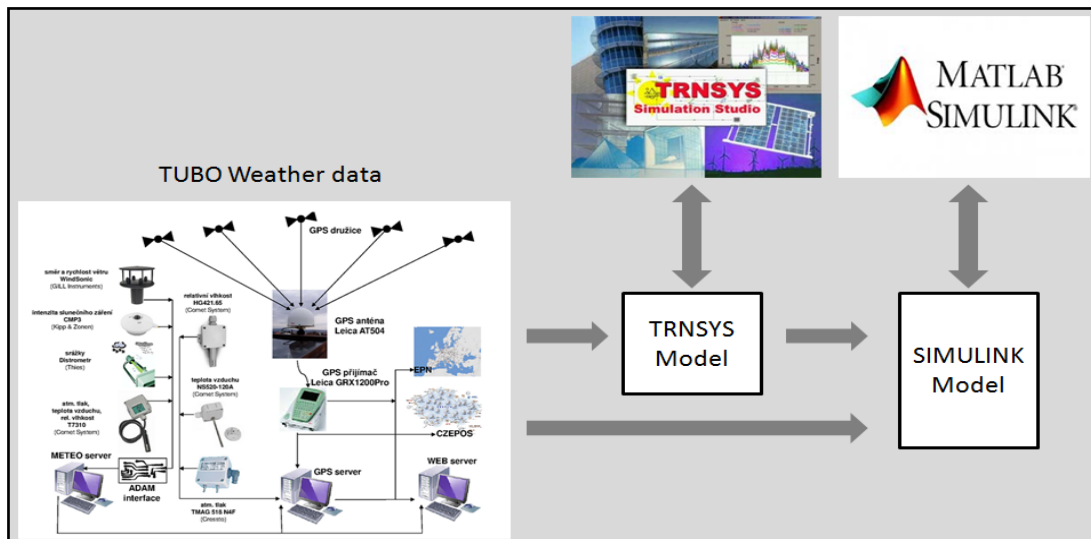

Figure 10: Import data from TUBO to TRNSYS and SIMULINK models

The designed model is shown in Figure 11. Where, the Solar Radiation Processor of this model includes: Total solar radiation on horizontal surface, Temperature and Relative Humidity

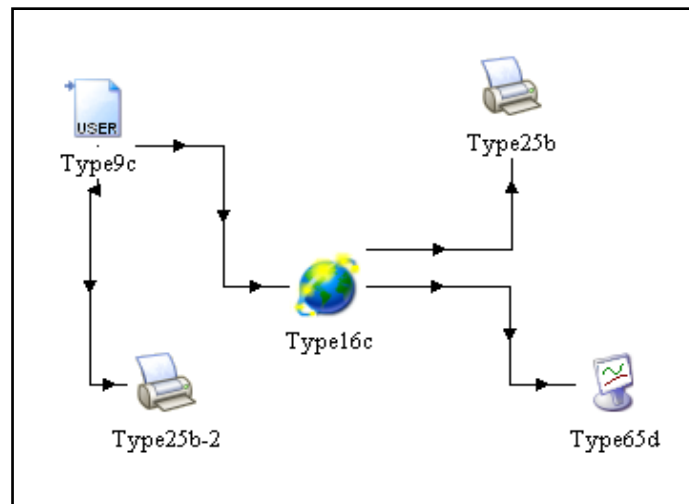

Figure 11: TRNSYS model

Solar radiation data is generally taken at one hour intervals and on a horizontal surface. In most TRNSYS simulations, estimates of radiation at time intervals other than one hour are required. Type16 component interpolates radiation data, calculates several quantities related to the position of the sun, and estimates solar radiation on a number of surfaces of either fixed or variable orientation. This instance of Type16 takes hourly integrated values of total horizontal solar radiation and computes the diffuse fraction using an algorithm that estimates cloudiness based on dry bulb and dew point temperature. It can use various algorithms to compute radiation on tilted surfaces.

The basic parameters in this model are as follows:

- *Surface Tracking Mode*: tracking mode is 1, because it is fixed surface.
- *Starting day*: The day of the year corresponding to the simulation start time. Every time the simulation start time is changed, the starting day must be changed or the radiation calculations will be inaccurate.
- *Latitude*: The latitude of the location being investigated. Latitude for the building area is 49 degrees north.
- *Solar constant*: is 4871.0 kJ/hr.m^2 .
- *Shift in solar time*: Since many of the calculations made in transforming insolation on a horizontal surface depend on the time of day, it is important that the correct solar time be used. This parameter is used to account for the differences between solar time and local time. The equation for the shift parameter is: $SHIFT = Lst - Lloc$. Where: Lst is the standard meridian for the local time zone. $Lloc$ is the longitude of the location in question. Longitude angles are positive towards West, negative towards East. The *UTC* is basically *GMT* (0 meridian). The shift is therefore $0 - (-16) = 16$.
- *Slope of surface*: The slope of the surface or tracking axis. The slope is positive when tilted in the direction of the azimuth. 0 = Horizontal, while 90 = Vertical facing toward azimuth. For all walls, slope is 90.
- *Azimuth of surface*: The solar azimuth angle is the angle between the local meridian and the projection of the line of sight of the sun onto the horizontal plane. Building has three external walls with the following (approximate) orientations: north-northwest (NNW), south-southeast (SSE) and east-northeast (ENE).

Figure 12 illustrates these angles and method of calculation:

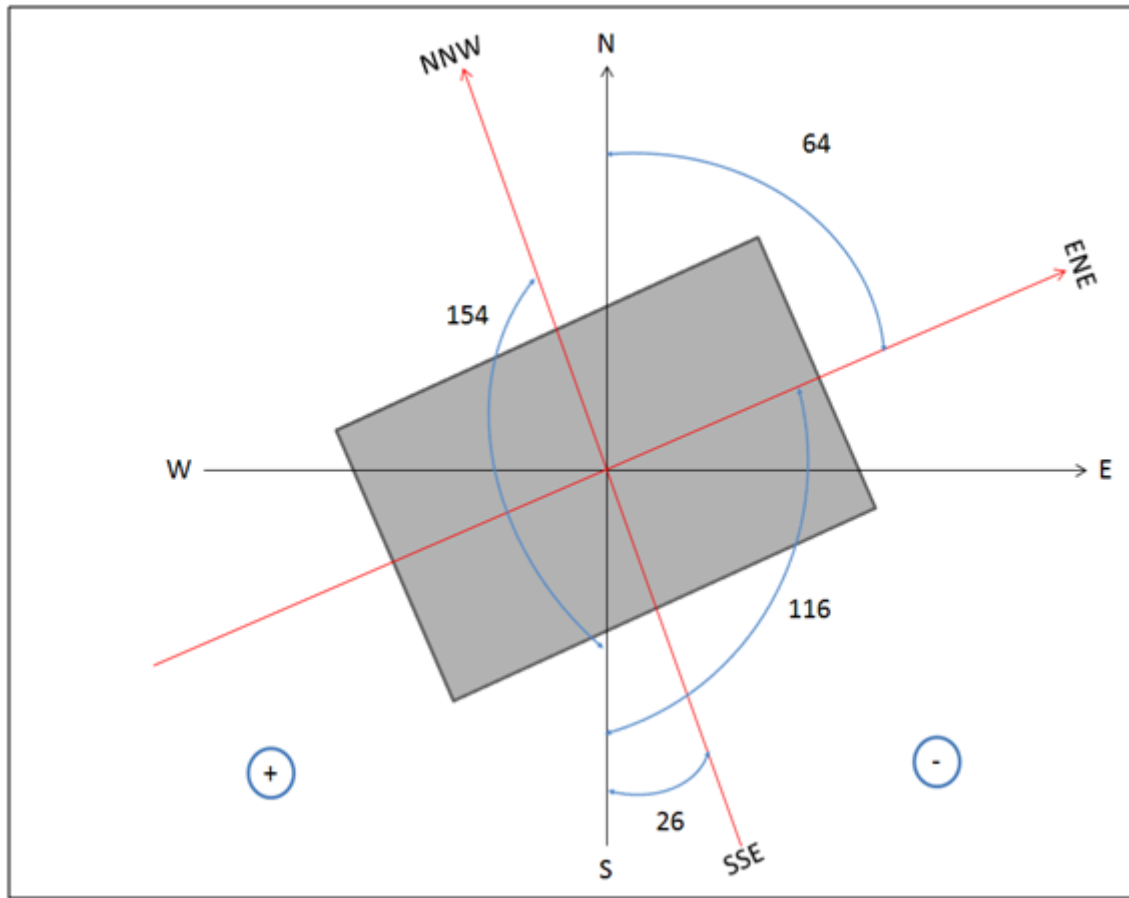

Figure 12: Azimuth of surfaces

The results are shown in Table 2.

Table 2: Azimuth of all walls

Wall	NNW	SSE	ENE
Azimuth	154	-26	-116

Through this model, the values of solar radiation incident on each wall in the building can be obtained, then these data can be converted into MAT files, so that can be used in the model has been designed by using MATLAB/SIMULINK.

4 MODELLING INDOOR THERMAL PROCESSES

4.1 Basics and background

It is needed for a better knowledge of the whole building Heat, Air & Moisture (HAM) balance [41] and its impact on the indoor environment, as well as energy consumption for heating cooling, air (de)humidification, in order to provide thermal comfort for occupants while reducing pollution and energy consumption. This is also the driving force behind the International Energy Agency Annex 41 [IEA Annex 41 2006].

A lot of computer applications already exist to deal with these issues. New developments tend to be in integrated building design [42]. Hence, integrated HAM models capable of covering HAM transfer between the outside, the building, the indoor air and the heating, ventilation and air-conditioning (HVAC) systems, are required. There is no one simulation tool can covers all issues [43]. But there is an option is the coupling of tools [44].

Modelling is to find mathematical equations to describe the dynamic response of the physical processes. It is usually achieved by using some known laws of (such as the law of conservation of energy, and conservation of mass). After modelling, the physical system can be simulated by using a particular software tool. Simulation model is an easy and quick way to show how the model responds to the inputs. Where, to simulate the process of responding to the changing in the output resulted by changing one step in input on a computer takes a few seconds, while in real time may take several hours or days before the systems settles. Thus, one of the most important reasons for the use of mathematical models is that it has the ability to save a great deal of money. The implementation of tests on the computer is easier and faster way, and at the same time can correct errors which are not exposed before the model is implemented in the real system.

Some methods are used to simulate the energy in buildings for predicting energy consumption and to determine the parameters of the indoor climate. Where, the results are used then to design building as required, so that to be able to meet the different requirements for energy consumption and indoor climate. The main principle of building energy simulation is to determine all the energy flows. Heat losses are through the building envelope (windows, walls ceiling and the floor), as well as through the ventilation system and infiltration. While thermal gains basically represent the solar heat gain through windows, internal heat from people, lighting and equipment. The model must also include the HVAC system, which aims to maintain the indoor environment at certain conditions. It is clear, that the actual indoor temperature is represented by a complex interaction between losses and gains, which contribute through a large number of variables on the energy balance. These variables are continuously changing, because the temperature outdoors is changing with time, as well as the solar heat gains and the internal heat gains. Air conditioning system must take these facts into account in order to maintain an acceptable temperature indoor with reducing energy consumption to a minimum.

In a mathematical model representing indoor environment, all what may affect the energy balance must be included in the model. It means that sub-models for walls, windows, ventilation system and all other components inside the building must be modelled. Hence, the options must be designed within a given level of assumptions that must be used in the model by using some approximate ways, where, it can be assumed that the air leakage rate is constant, although this is not realistic. Options and the assumptions used affect the complexity of the model. As the detailed model with many input parameters gives detailed results, but will also lead to the complexity of the model and causing difficulties to run it.

So, balance between accuracy and complexity must be taken into account so that model can get the required accuracy at the lowest possible complexity.

The mathematical model is run by using software for the application of the simulation process. Where that after the completion of the initial implementation of the model, it is necessary to validate the model in order to make sure that the results obtained are close to the real parameters, where, the results can be validated based on measurements made under controlled conditions.

An advantage of simulation is that results from several simulations with varying parameters can improve design of the building, and resolve unexpected problems in internal climate.

The common modelling approaches of detailed energy simulation can be summarized as follows [45]:

- Response function method under time domain.
- Numerical method using finite differences.
- Response function method under frequency domain.
- Numerical method using control volume heat balance.
- Numerical method using finite element approach.

The MATLAB environment has advanced capabilities to simulate indoor thermal processes. A whole building model has already been developed in MATLAB. This model, called HAMBBase (Heat, Air and Moisture model for Building and Systems Evaluation). This model has continuously been improved and implemented in MATLAB. Important features for this work are: multi-zone modelling, solar and shadow calculations and multi climate conditions.

SIMULINK is a software package for modelling, simulating, and analyzing dynamical systems. It supports linear and non-linear systems, modelled in continuous time, sampled time or a hybrid of the two. SIMULINK includes a block library of sinks, sources, linear and non-linear components and connectors [46]. Important features are: libraries of predefined blocks including controllers, ability to interface with other simulation programs, ordinary differential equations (ODE) modelling that can accommodate continuous, discrete, and hybrid systems [47]. Modelling the indoor environment can be implemented using SIMULINK, based on Ordinary Differential Equations (ODEs). The basic principle for modelling thermal processes in the building is based on the following laws:

Law of conservation of mass

The law of conservation of mass states that the mass of a closed system will remain constant over time, the mass can neither be created nor be destroyed. This means that mass stored in a fixed volume is only altered due to mass inputs and mass outputs, and is often referred to as mass balance.

Law of conservation of energy

The law of conservation of energy states that the energy of a closed system will remain constant over time. As for the mass, energy can neither be created nor destroyed. For that reason energy stored in a fixed volume is only altered due to energy inputs and energy outputs. It can however change form.

The range of heat and mass transfer processes that would take place in buildings is as illustrated in Figure 13.

The classroom is separated from the outdoors by an external wall and a window, and from adjoining rooms at the sides by internal partitions, and at above and below by a ceiling and a floor slab. The room is equipped with a HVAC system that would supply heating or cooling to

the room by circulating air between the room and the air-handling unit via the supply and return air ducts. As shown, the heat and mass transfer processes that would take place in a building include:

- a. Conduction heat transfer through the building fabric elements, including the external walls, roof, ceiling and floor slabs and internal partitions.
- b. Solar radiation transmission and conduction through window glazing.
- c. Infiltration of outdoor air and air from adjoining rooms.
- d. Heat and moisture dissipation from the lighting, equipment, occupants and other materials inside the room.
- e. Heating or cooling and humidification or dehumidification provided by the HVAC system.

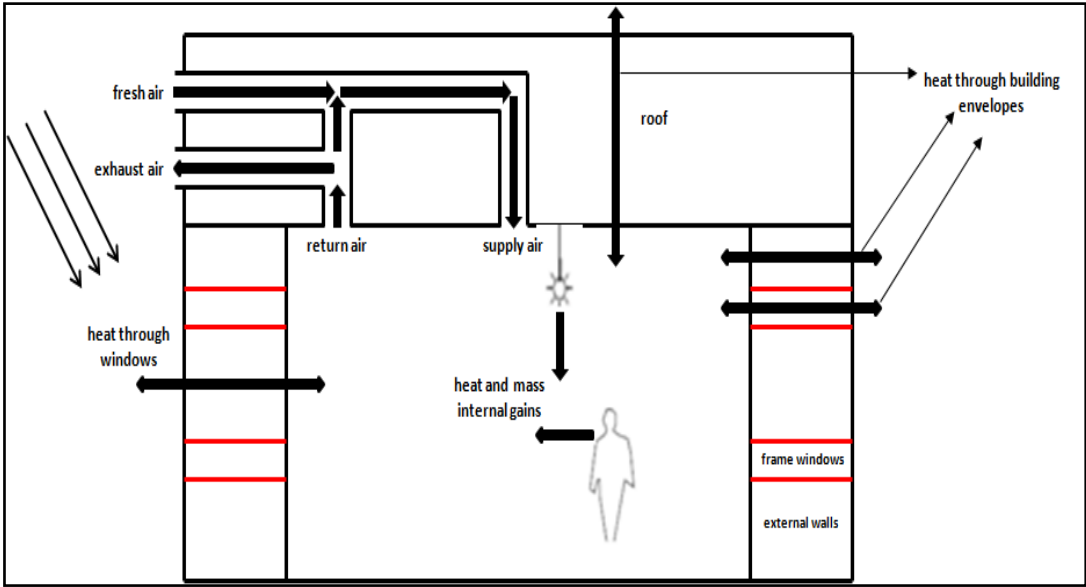

Figure 13: Heat and mass transfer in the building

Figure 14 shows a diagram of the building, where, the main dimensions in mm are clarified.

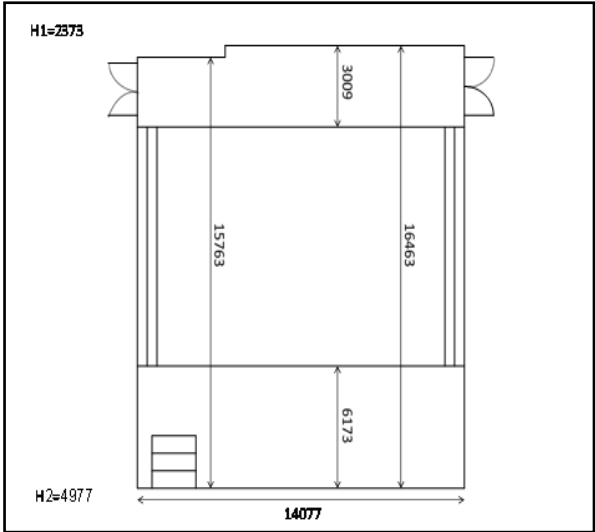

Figure 14: Dimensions of the building

The volume of indoor space is 910 m³. There are two external walls with the same dimensions. One of them in north-northwest orientation, while the other in south-southeast orientation. Each wall is covered partially with a wood layer. The area of the wood-covered part is 28.63 m², while the area of concrete part is 14.65 m² as shown in Figure 15. Further data are in Table 3.

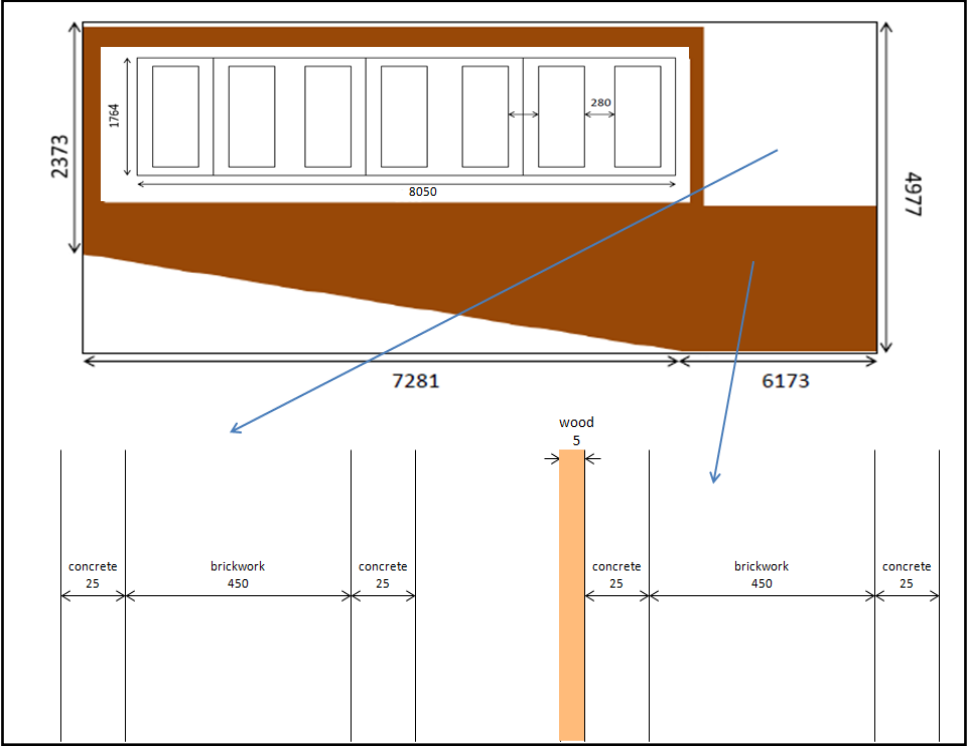

Figure 15: External walls (north-northwest, and south-southeast)

Table 3: Dimensions and properties of materials of all layers in external wall

External wall from inside to outside direction	Thickness [mm]	Thermal conductivity [W/m.K]	Specific heat capacity [J/kg.K]	Density [kg/m ³]
Wood	5	0.17	2000	700
Concrete	25	1.7	920	2300
Brick	450	0.8	800	1700
Concrete	25	1.7	920	2300

There is a steel frame for the window in each wall. The area of glass is 9.64 m², while area of frame is 4.35 m², as shown in Figure 16. Further data are in Table 4.

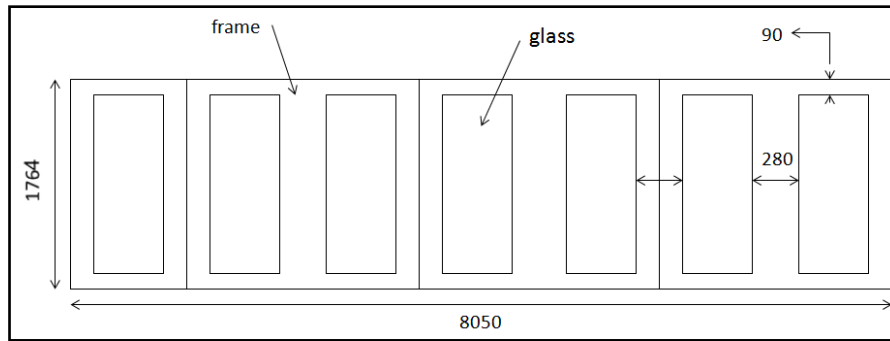

Figure 16: Windows

Table 4: Properties of window frame

Window frame	Thermal conductivity [W/m.K]	Specific heat capacity [J/kg.K]	Density [kg/m ³]
Steel	16	490	7820

There is another external wall with east-northeast orientation, is covered partially with a wood layer too, with the same layers exactly. The area of the wood-covered part is 36.65 m², while area of concrete part is 33.40 m², as shown in Figure 17.

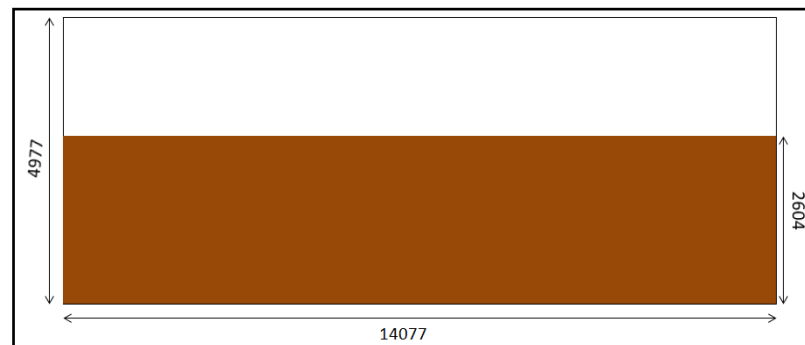

Figure 17: External wall (east-northeast)

With regard to roof, as shown in Figure 18, there is an air gap with thickness 300 mm, is assumed that has the same indoor temperature, connected with a concrete layer. Above roof, there is a room containing equipment for HVAC system. Its temperature changes between the indoor and outdoor temperatures, and it has been obtained by direct measurement. Table 5 includes the dimensions and properties of the concrete layer.

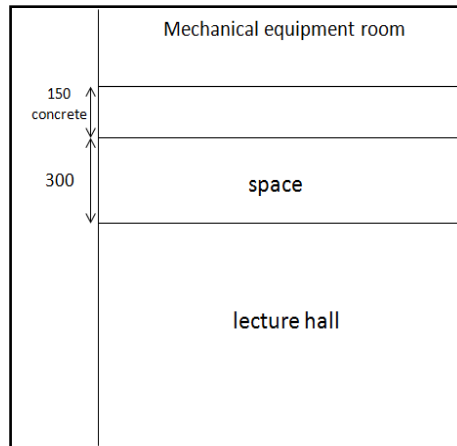

Figure 18: Roof

Table 5: Dimensions and properties of roof

Roof	Area [m ²]	Thickness [mm]	Thermal conductivity [W/m.K]	Specific heat capacity [J/kg.K]	Density [kg/m ³]
Concrete	231.75	150	1.7	920	2300

There is an inner wall connected with conditioned indoor space, while under the floor there is another classroom conditioned too. Since the air temperature in the adjacent indoor spaces (hallways, classroom) is the almost the same as in the lecture hall, the heat transfer through internal walls has been neglected in the model.

4.2 Modelling heat transfer indoors

The method used to model the interactions between the instantaneous loads and system models is the method of heat equilibrium, where, it requires solving a set of equations for heat transfer and temperature of the indoor air in order to determine the loads indoors. Where, the indoor temperature can be calculated based on the indoor environmental conditions, such as internal loads, the interactions between the surfaces, infiltration, ventilation, and air handling system. And then, the concept of energy balance is used to for determining the temperature inside at which the indoor space become balanced with the heating or cooling provided by the system, so that can maintain indoor climate conditions comfortable for occupants.

Energy balance indoors can be expressed by the following equation [48]:

$$(\rho_{air} \cdot c_{p\ air} \cdot V_{indoor} + C_{internal}) \frac{dT_{indoor}}{dt} = Q_{ventilation} + Q_{envelopes} + Q_{windows} + Q_{gains} \quad (19)$$

Where:

ρ_{air} [kg/m³]: density of air.

$c_{p\ air}$ [J/kg.K]: specific heat capacity of air.

V_{indoor} [m³]: indoor space volume.

$C_{internal}$ [J/K]: lumped thermal capacity of the building, which is the sum of the internal capacities of all internal layers, where, it is assumed that indoor air temperature and the temperature of all internal layers are the same

T_{indoor} [K]: indoor temperature.

$Q_{ventilation}$ [W]: heat loss/gain through ventilation.

$Q_{envelopes}$ [W]: heat exchange through building envelopes.

$Q_{windows}$ [W]: heat exchange through windows.

Q_{gain} [W]: internal gains (occupants and equipments, etc).

According to Figure 19, heat transfer through the building envelopes can be expressed by the following equation [49]:

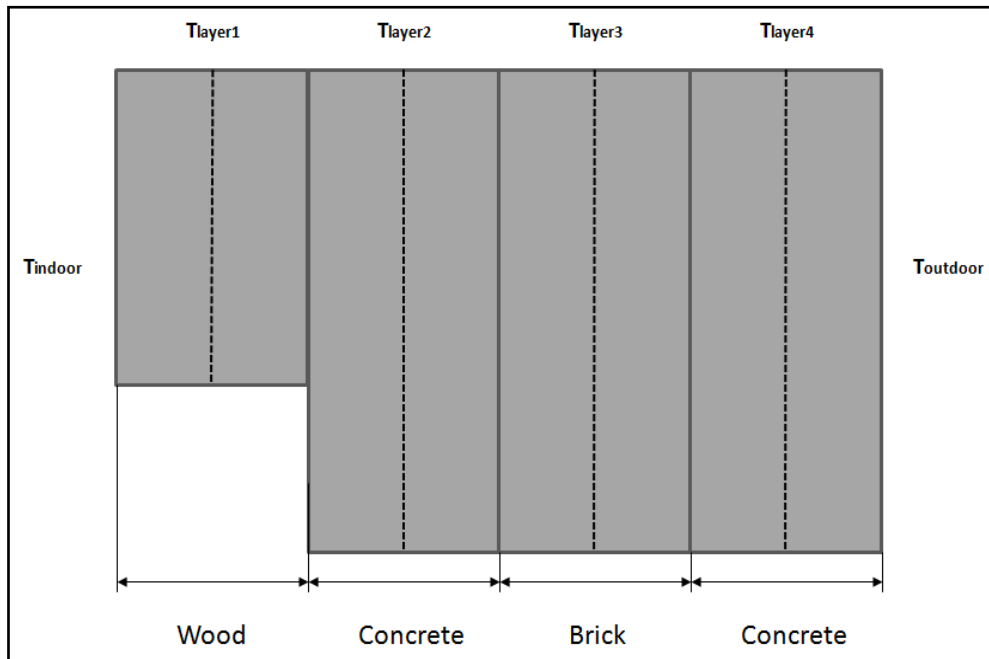

Figure 19: Different layers of the external wall

$$Q_{envelope} = \frac{1}{\frac{1}{h_{inside}} + \frac{l_1}{2k_1}} A_1 (T_1 - T_{indoor}) + \frac{1}{\frac{1}{h_{inside}} + \frac{l_{frame}}{2k_{frame}}} A_{frame} (T_{frame} - T_{indoor}) + \frac{1}{\frac{1}{h_{inside}} + \frac{l_{roof}}{2k_{roof}}} A_{roof} (T_{roof} - T_{indoor}) \quad (20)$$

Where:

h_{inside} [W/m².K]: heat transfer coefficient inside. In this model, is set to be 8 W/m².K.

l_1 [m]: thickness of wood layer (first layer inside).

k_1 [W/m.K]: thermal conductivity of wood layer (first layer inside).

A_1 [m²]: area of wood layer (first layer inside).

T_1 [°C]: temperature of wood layer (first layer inside).

l_{frame} [m]: thickness of windows frame.

k_{frame} [W/m.K]: thermal conductivity of windows frame.

A_{frame} [m²]: area of windows frame.

T_{frame} [°C]: temperature of windows frame.

l_{roof} [m]: thickness of concrete layer of roof.

k_{roof} [W/m.K]: thermal conductivity of concrete layer of roof.

A_{roof} [m²]: area of concrete layer of roof.

T_{roof} [°C]: temperature of concrete layer of roof.

4.2.1 Model of heat transfer through external walls

On the other hand, the conduction heat transfer through an external wall as shown in Figure 20 is the effect of the convective heat that the surface at each side of the element is exchanging with the surrounding air. For an external wall, the radiant heat exchange at the external side includes the absorbed solar radiation, including both direct and diffuse radiation.

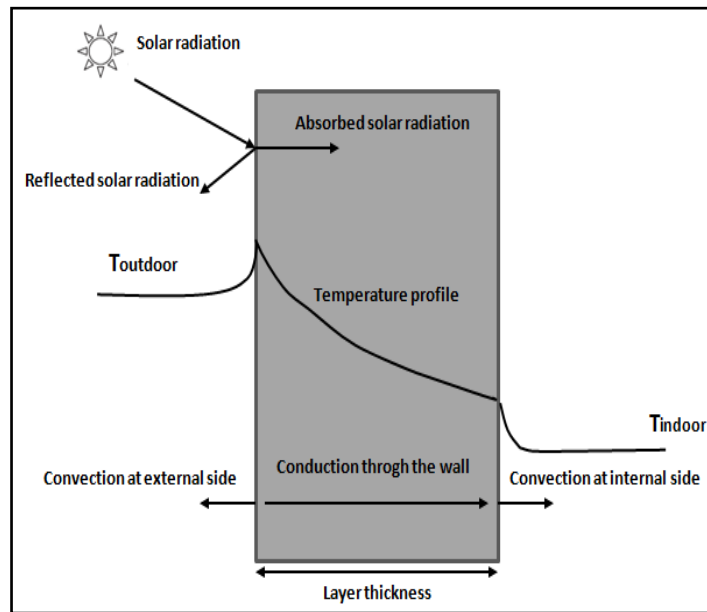

Figure 20: Heat transfer through external wall

Energy balance equation for wood layer (first layer inside) can be expressed by the following equation [49]:

$$\rho_1 c_{p1} V_1 \frac{dT_1}{dt} = \frac{1}{\frac{1}{h_{inside}} + \frac{l_1}{2.k_1}} A_1 (T_{indoor} - T_1) - \frac{2.k_1.k_2}{l_1.k_2 + l_2.k_1} A_2 (T_1 - T_2) \quad (21)$$

Where:

ρ_1 [kg/m³]: density of wood layer (first layer inside).

c_{p1} [J/kg.K]: specific heat capacity of wood layer (first layer inside).

V_1 [m³]: volume of wood layer (first layer inside).

k_2 [W/m.K]: thermal conductivity of first concrete layer (second layer inside).

l_2 [m]: thickness of first concrete layer (second layer inside).

A_2 [m²]: area of first concrete layer (second layer inside).

T_2 [°C]: temperature of first concrete layer (second layer inside).

By rearranging equation (21), T_1 can be calculated as follows:

$$T_1 = \int \left(\frac{1}{\frac{1}{h_{inside}} + \frac{l_1}{2.k_1}} A_1(T_{indoor} - T_1) - \frac{2.k_1.k_2}{l_1.k_2 + l_2.k_1} A_2(T_1 - T_2) \right) / \rho_1.c_{p1}.V_1 \quad (22)$$

After knowing T_1 , the first quantity of the right side of equation (20):

$\frac{1}{\frac{1}{h_{inside}} + \frac{l_1}{2.k_1}} A_1(T_1 - T_{indoor})$ can be simulated. Where, this quantity and equation (22) can be

simulated by using MATLAB/SIMULINK, as shown in Figure 21.

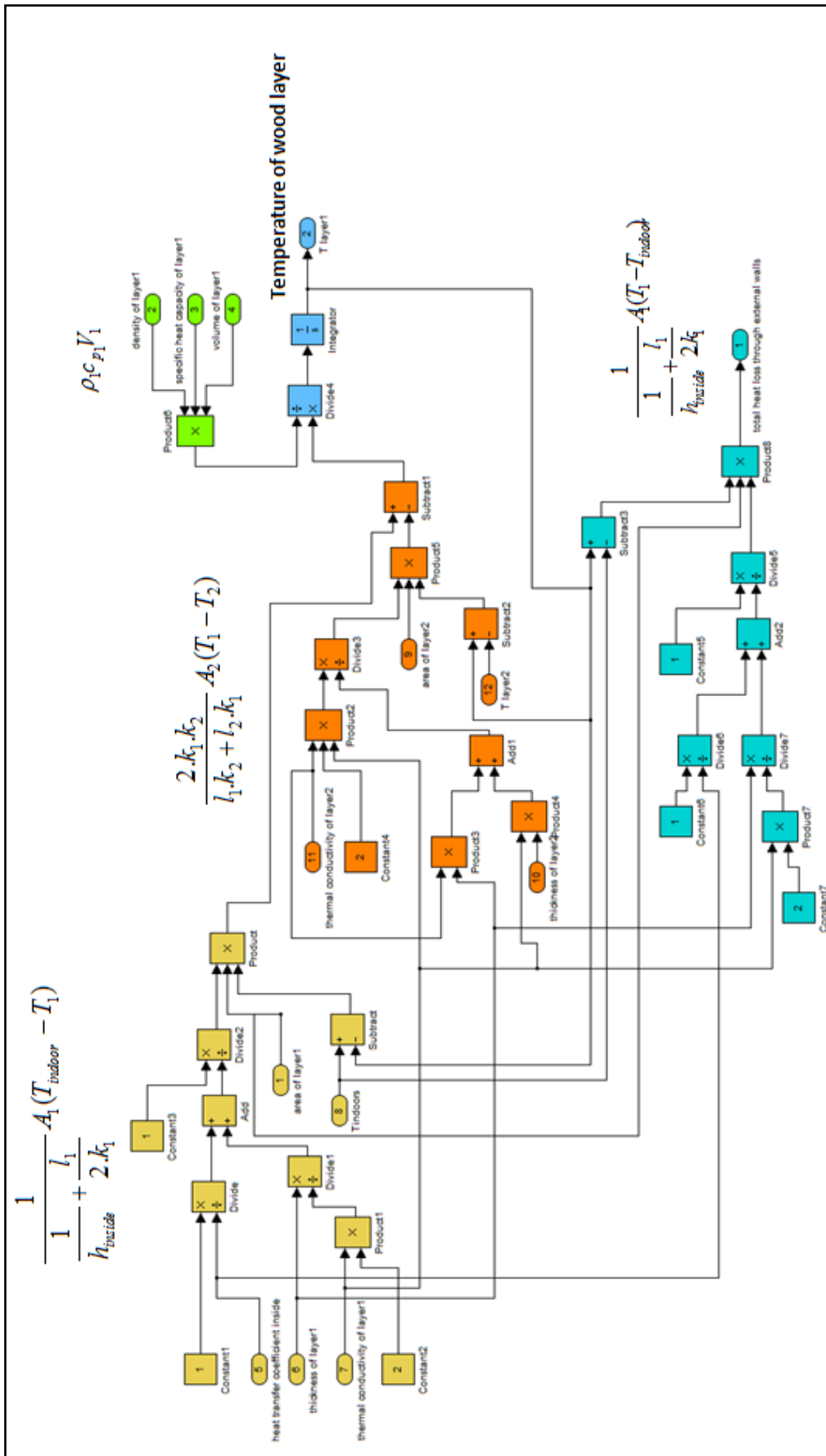

Figure 21: Model of wood layer (first layer inside)

According to equation (22), temperature of next layer must be calculated. Hence, energy balance equation for first concrete layer (second layer inside) can be expressed by the following equation [49]:

$$\rho_2 \cdot c_{p2} \cdot V_2 \frac{dT_2}{dt} = \frac{2 \cdot k_1 \cdot k_2}{l_1 \cdot k_2 + l_2 \cdot k_1} A_2 (T_1 - T_2) - \frac{2 \cdot k_3 \cdot k_2}{l_3 \cdot k_2 + l_2 \cdot k_3} A_3 (T_2 - T_3) \quad (23)$$

Where:

ρ_2 [kg/m³]: density of first concrete layer (second layer inside).

c_{p2} [J/kg.K]: specific heat capacity of first concrete layer (second layer inside).

V_2 [m³]: volume of first concrete layer (second layer inside).

k_3 [W/m.K]: thermal conductivity of brick layer (third layer inside).

l_3 [m]: thickness of brick layer (third layer inside).

A_3 [m²]: area of brick layer (third layer inside).

T_3 [°C]: temperature of brick layer (third layer inside).

By rearranging equation (23), T_2 can be calculated as follows:

$$T_2 = \int \left(\frac{2 \cdot k_1 \cdot k_2}{l_1 \cdot k_2 + l_2 \cdot k_1} A_2 (T_1 - T_2) - \frac{2 \cdot k_3 \cdot k_2}{l_3 \cdot k_2 + l_2 \cdot k_3} A_3 (T_2 - T_3) \right) / \rho_2 \cdot c_{p2} \cdot V_2 \quad (24)$$

Equation (24) can be simulated by using MATLAB/SIMULINK, as shown in Figure 22.

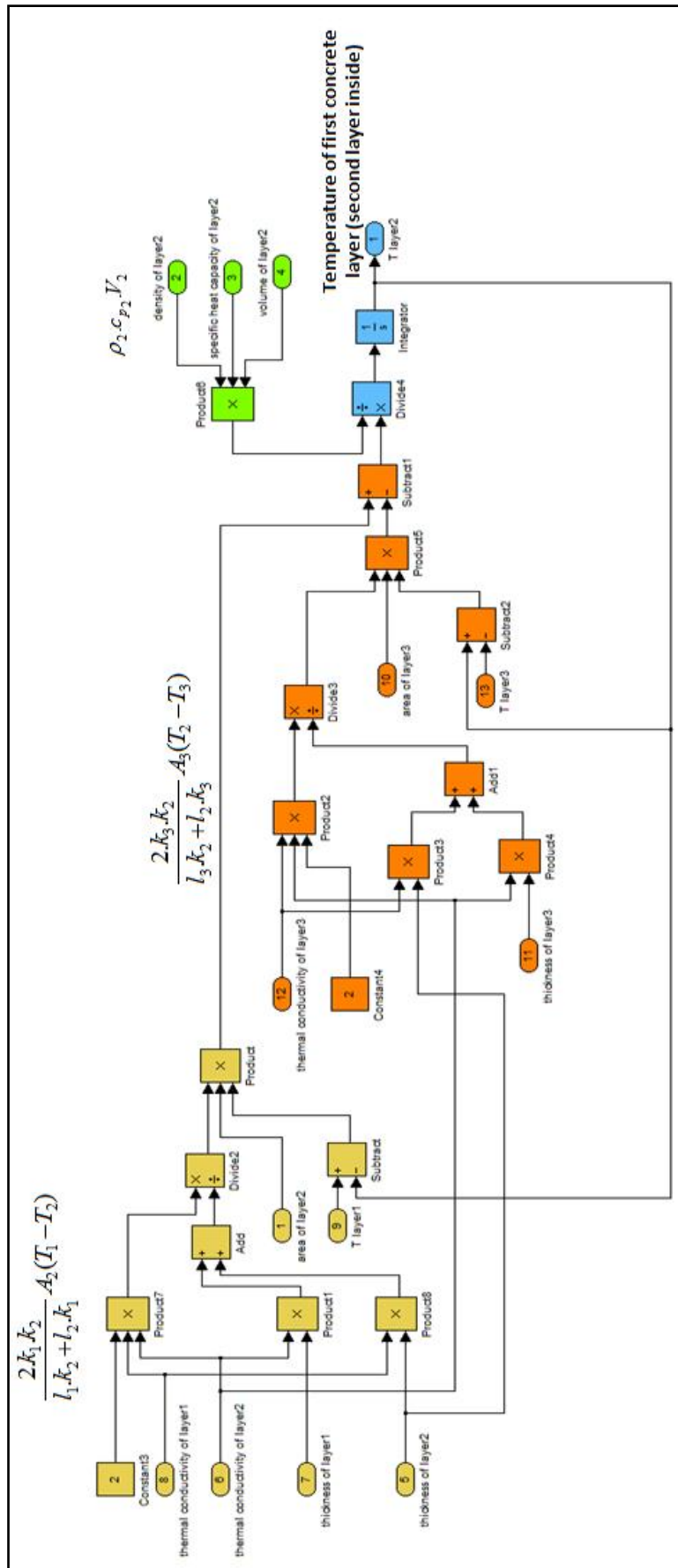

Figure 22: Model of first concrete layer (second layer)

According to equation (24), temperature of next layer must be also calculated. Hence, energy balance equation for brick layer (third layer inside) can be expressed by the following equation [49]:

$$\rho_3 c_{p3} V_3 \frac{dT_3}{dt} = \frac{2.k_2.k_3}{l_2.k_3 + l_3.k_2} A_3(T_2 - T_3) - \frac{2.k_4.k_3}{l_4.k_3 + l_3.k_4} A_4(T_3 - T_4) \quad (25)$$

Where:

ρ_3 [kg/m³]: density of brick layer (third layer inside).

c_{p3} [J/kg.K]: specific heat capacity of brick layer (third layer inside).

V_3 [m³]: volume of brick layer (third layer inside).

k_4 [W/m.K]: thermal conductivity of second concrete layer (fourth layer).

l_4 [m]: thickness of second concrete layer (fourth layer).

A_4 [m²]: area of second concrete layer (fourth layer).

T_4 [°C]: temperature of second concrete layer (fourth layer).

By rearranging equation (25), T_3 can be calculated as follows:

$$T_3 = \int \left(\frac{2.k_2.k_3}{l_2.k_3 + l_3.k_2} A_3(T_2 - T_3) - \frac{2.k_4.k_3}{l_4.k_3 + l_3.k_4} A_4(T_3 - T_4) \right) / \rho_3.c_{p3}.V_3 \quad (26)$$

Equation (26) can be simulated by using MATLAB/SIMULINK as shown in Figure 23.

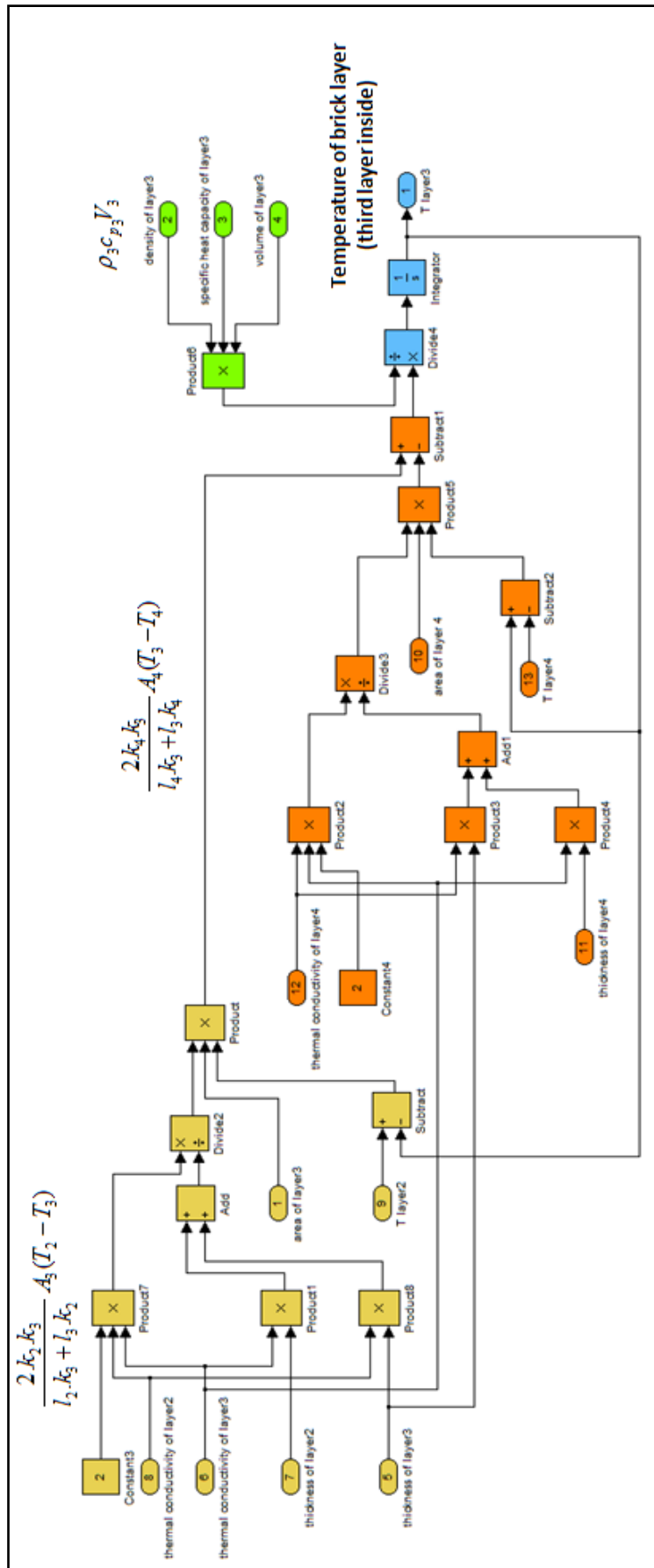

Figure 23: Model of brick layer (third layer inside)

By the same way, according to equation (26), temperature of next layer must be also calculated. Hence, energy balance equation of second concrete layer (fourth layer) can be expressed by the following equation [49]:

$$\rho_4 \cdot c_{p4} \cdot V_4 \frac{dT_4}{dt} = \frac{2 \cdot k_4 \cdot k_3}{l_4 \cdot k_3 + l_3 \cdot k_4} A_4 (T_3 - T_4) - \frac{1}{\frac{1}{h_{outside}} + \frac{l_4}{2 \cdot k_4}} A_{outside} (T_4 - T_{so,walls}) \quad (27)$$

Where:

ρ_4 [kg/m³]: density of second concrete layer (fourth layer).

c_{p4} [J/kg.K]: specific heat capacity of second concrete layer (fourth layer).

V_4 [m³]: volume of second concrete layer (fourth layer).

$A_{outside}$ [m²]: area of outside surface.

$h_{outside}$ [W/m²K]: heat transfer coefficient outside. In this model, from October to March is set to be 25 W/m²K, while for other months is set to be 18 W/m²K.

$T_{so,walls}$ [°C]: sol-air temperature for external walls, which can be modelled, as shown in Figure 24.

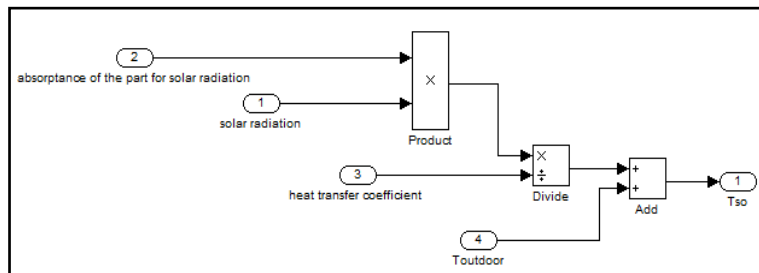

Figure 24: Model of sol-air temperature for external walls

It is clear that in the absence of radiation, the sol-air temperature is equal to the outdoor air temperature. The difference between sol-air temperature and outdoor air temperature increases as the amount of radiation incident on the outer surface increases and the external heat transfer coefficient decreases. Since the outdoor air temperature and solar radiation continuously vary over time, sol-air temperature continuously changes over time too.

Considering that there are three walls in different orientations, there are three different values of sol-air temperatures, depending on the intensity of solar radiation incident on each wall. Where, values of intensity of solar radiation incident on each wall have been calculated by using TRNSYS model.

By rearranging equation (27), T_4 can be calculated as follows:

$$T_4 = \int \left(\frac{2 \cdot k_4 \cdot k_3}{l_4 \cdot k_3 + l_3 \cdot k_4} A_4 (T_3 - T_4) - \frac{1}{\frac{1}{h_{outside}} + \frac{l_4}{2 \cdot k_4}} A_{outside} (T_4 - T_{so,walls}) \right) / \rho_4 \cdot c_{p4} \cdot V_4 \quad (28)$$

Equation (28) can be simulated by using MATLAB/SIMULINK, as shown in Figure 25.

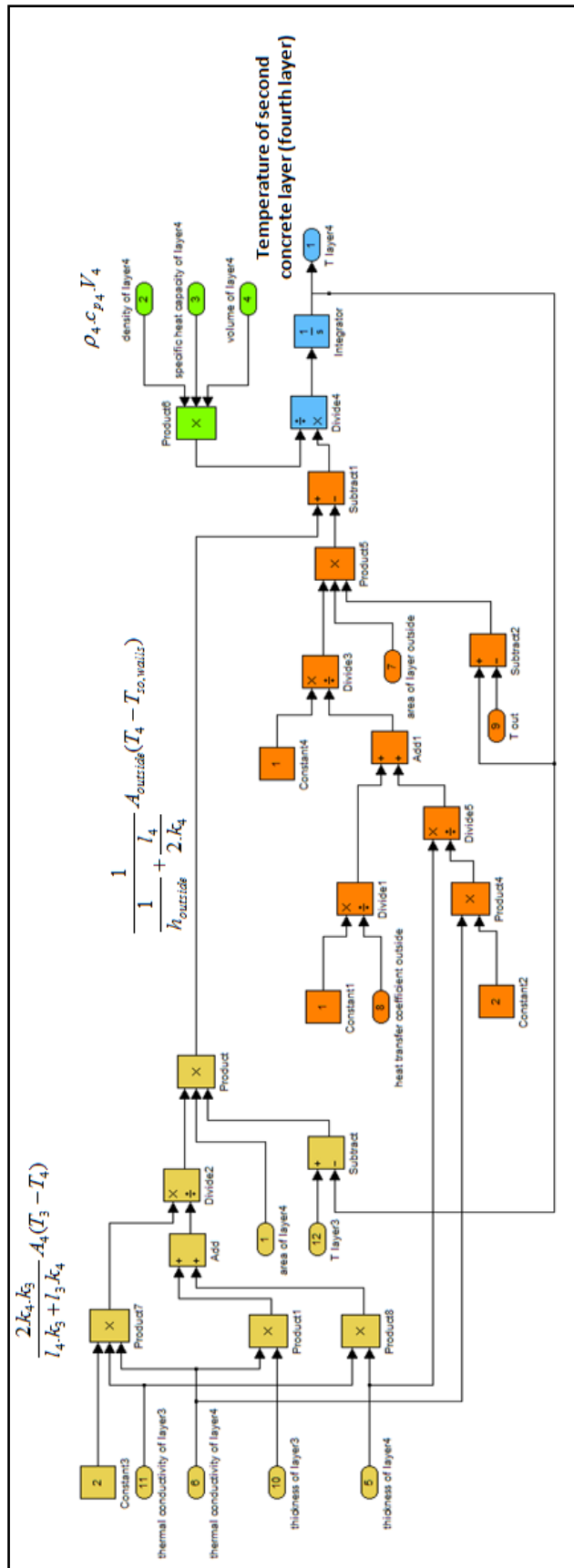

Figure 25: Model of second concrete layer (fourth layer)

After modelling heat transfer through each layer of the external wall, these layers can be linked together to form the complete model of the external wall, as shown in Figure 26.

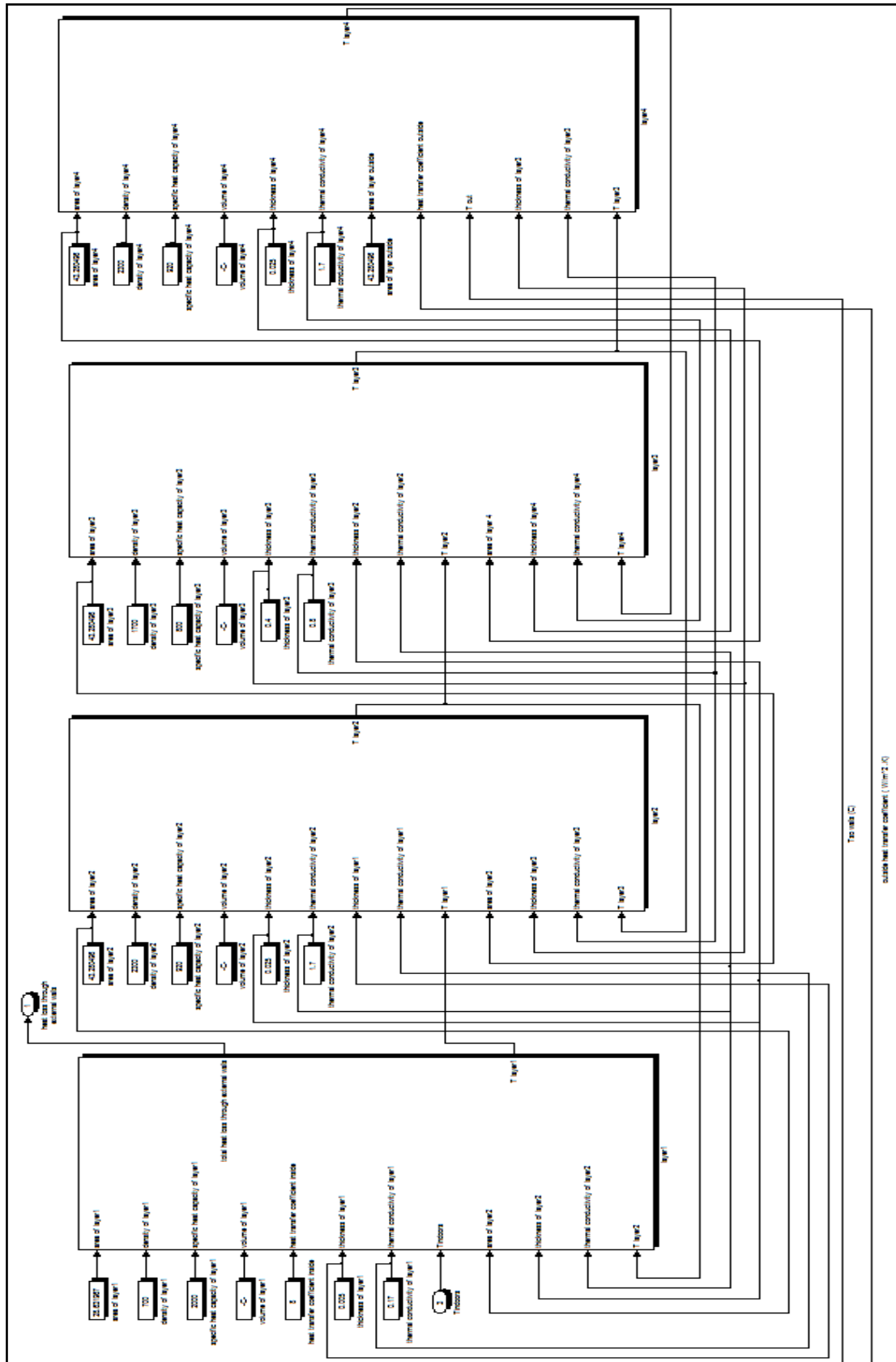

Figure 26: Model of all layers connected of the external wall

After calculating temperatures of all layers, T_j can be calculated, and then the first quantity of the right side of equation (20) can be calculated.

4.2.2 Model of heat transfer through windows frame

Energy balance equation of frame can be expressed by the following equation [49]:

$$\rho_{frame} \cdot c_{p,frame} \cdot V_{frame} \frac{dT_{frame}}{dt} = \frac{1}{\frac{1}{h_{inside}} + \frac{l_{frame}}{2 \cdot k_{frame}}} A_{frame} (T_{indoor} - T_{frame}) - \frac{1}{\frac{1}{h_{outside}} + \frac{l_{frame}}{2 \cdot k_{frame}}} A_{frame} (T_{frame} - T_{so,frame}) \quad (29)$$

Where:

ρ_{frame} [kg/m³]: density of frame.

$c_{p,frame}$ [J/kg.K]: specific heat capacity of frame.

V_{frame} [m³]: volume of frame.

$T_{so,frame}$ [°C]: sol-air temperature for frame.

By rearranging equation (29), T_{frame} can be calculated as follows:

$$T_{frame} = \int \left(\frac{1}{\frac{1}{h_{inside}} + \frac{l_{frame}}{2 \cdot k_{frame}}} A_{frame} (T_{indoor} - T_{frame}) - \frac{1}{\frac{1}{h_{outside}} + \frac{l_{frame}}{2 \cdot k_{frame}}} A_{frame} (T_{frame} - T_{so,frame}) \right) / \rho_{frame} \cdot c_{p,frame} \cdot V_{frame} \quad (30)$$

After knowing T_{frame} , the second quantity of the right side of equation (20) can be simulated:

$\frac{1}{\frac{1}{h_{inside}} + \frac{l_{frame}}{2 \cdot k_{frame}}} A_{frame} (T_{frame} - T_{indoor})$. Where, this quantity and equation (30) can be simulated by

using MATLAB/SIMULINK, as shown in Figure 27.

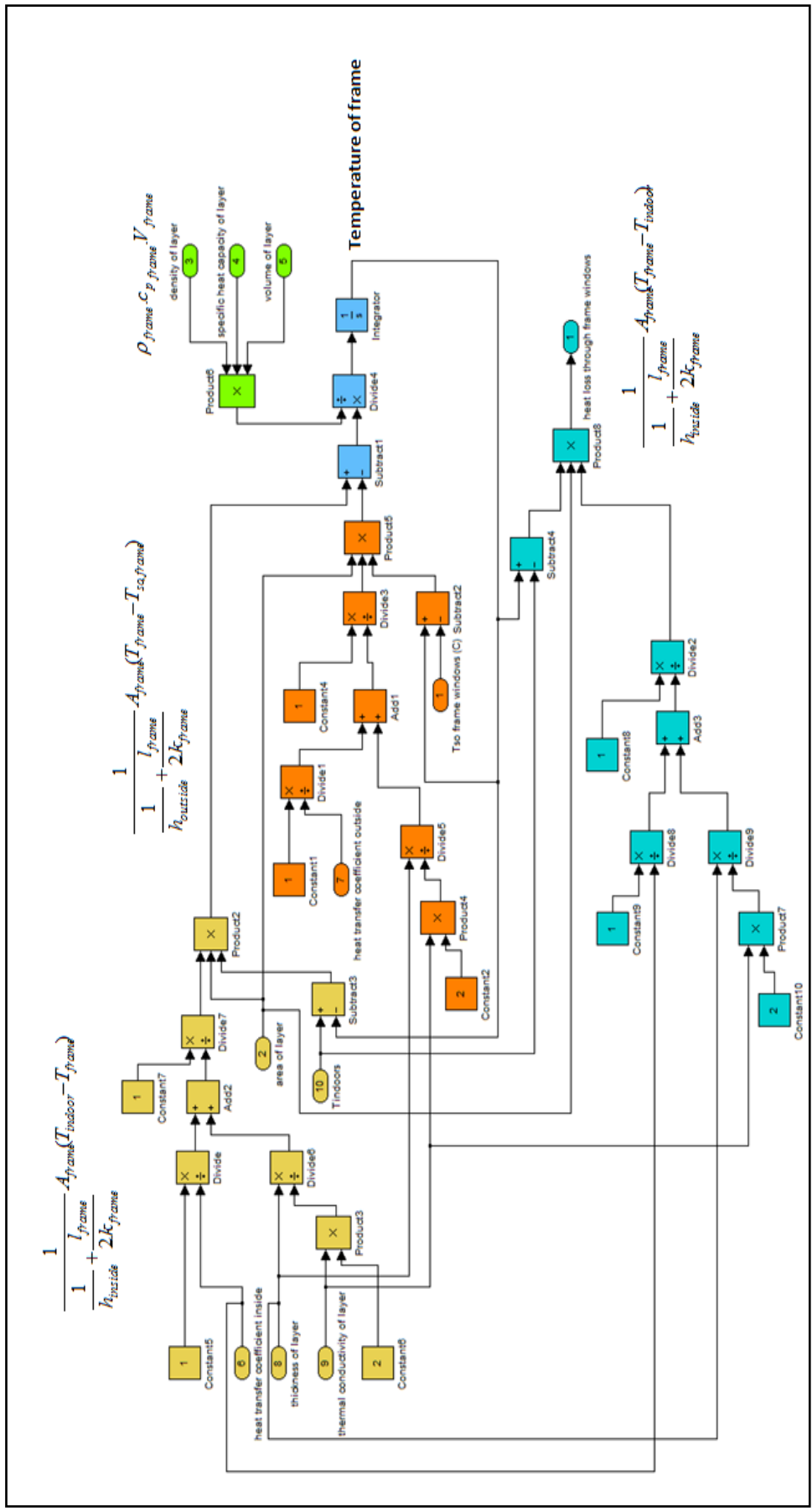

Figure 27: Model of heat transfer through windows frame

4.2.3 Model of heat transfer through roof

Energy balance equation of roof can be expressed by the following equation [49]:

$$\rho_{roof} \cdot c_{p,roof} \cdot V_{roof} \frac{dT_{roof}}{dt} = \frac{1}{\frac{1}{h_{inside}} + \frac{l_{roof}}{2k_{roof}}} A_{roof} (T_{indoor} - T_{roof}) - \frac{1}{\frac{1}{h_{outside}} + \frac{l_{roof}}{2k_{roof}}} A_{roof} (T_{roof} - T_{out,roof}) \quad (31)$$

Where:

ρ_{roof} [kg/m³]: density of concrete layer of roof.

$c_{p,roof}$ [J/kg.K]: specific heat capacity of concrete layer of roof.

V_{roof} [m³]: volume of concrete layer of roof.

$T_{out,roof}$ [°C]: temperature out roof.

By rearranging equation (31), T_{roof} can be calculated as follows:

$$T_{roof} = \int \left(\frac{1}{\frac{1}{h_{inside}} + \frac{l_{roof}}{2k_{roof}}} A_{roof} (T_{indoor} - T_{roof}) - \frac{1}{\frac{1}{h_{outside}} + \frac{l_{roof}}{2k_{roof}}} A_{roof} (T_{roof} - T_{out,roof}) \right) / \rho_{roof} \cdot c_{p,roof} \cdot V_{roof} \quad (32)$$

After knowing T_{roof} , the third quantity of the right side of equation (20) can be simulated.

$\frac{1}{\frac{1}{h_{inside}} + \frac{l_{roof}}{2k_{roof}}} A_{roof} (T_{roof} - T_{indoor})$. Where, this quantity and equation (32) can be simulated by using

MATLAB/SIMULINK, as shown in Figure 28.

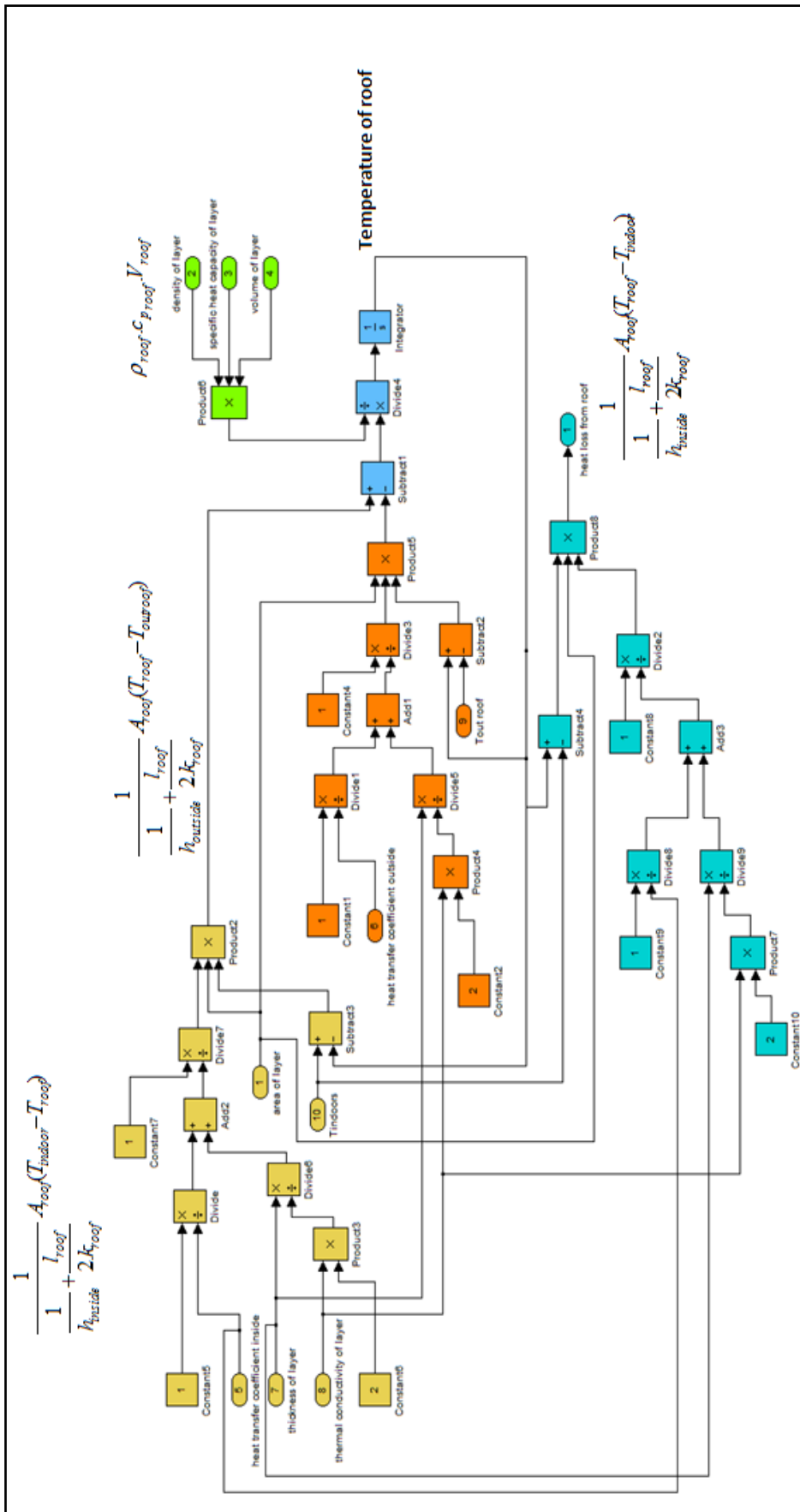

Figure 28: Model of heat transfer through roof

4.2.4 Model of heat transfer through windows

The heat transfer through the window is shown in Figure 29. The window glass transmits part of the incident solar radiation into the indoor space. While the solar radiation penetrates the glass pane, some of the energy will be absorbed by the glass, leading to an increase in the glass temperature, which will cause heat to flow in both the indoor and the outdoor directions, first by conduction within the glass and then by convection and radiation at the surfaces at both sides.

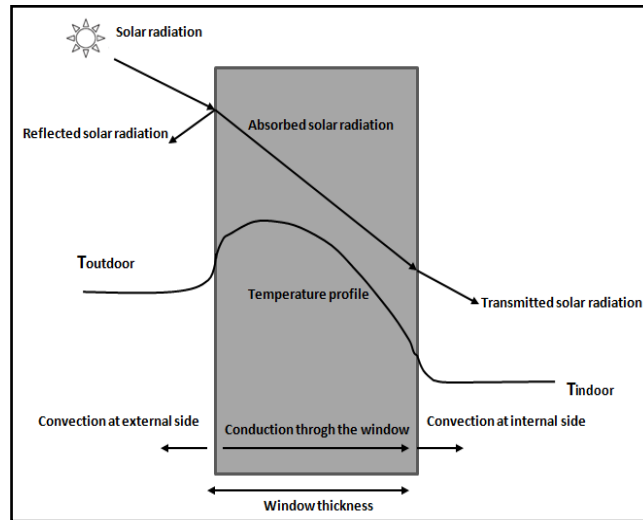

Figure 29: Heat transfer through windows

Heat Transferred through the window can be expressed by the following equation [50]:

$$Q_{windows} = A_{windows} U_{windows} (T_{so, windows} - T_{indoor}) + I \cdot SC \cdot A_{windows} \quad (33)$$

Where:

$Q_{windows}$ [W]: heat exchange through windows.

$A_{windows}$ [m²]: windows area.

$U_{windows}$ [W/m².K]: overall heat transfer coefficient of windows.

$T_{so, windows}$ [°C]: sol-air temperature for windows. Where, absorptance for solar radiation is assumed to be around 0.1.

T_{indoor} [°C]: indoor temperature.

I [W/m²]: solar radiation incident on the window.

SC [-]: solar heat gain coefficient.

Equation (33) can be simulated by using MATLAB/SIMULINK, as shown in Figure 30.

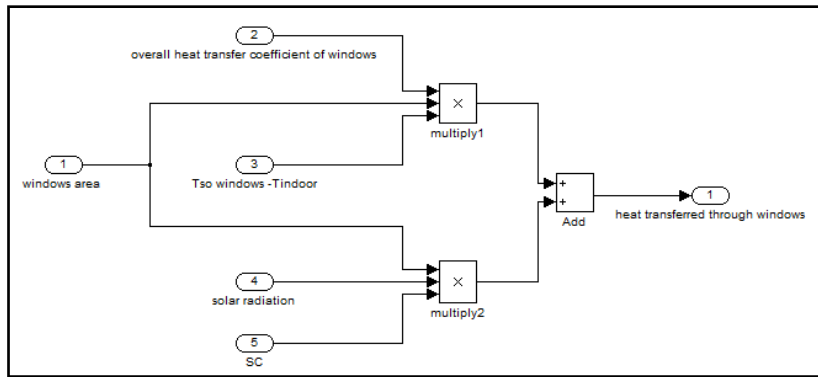

Figure 30: Model of heat transfer through windows

4.2.5 Model of heat loss/gain due to ventilation

Ventilation heat loss/gain can be calculated as follows [51]:

$$Q_{ventilation} = \frac{N \cdot \rho_{air} \cdot V_{indoor} \cdot c_{p\ air}}{3600} (T_{outdoor} - T_{indoor}) \quad (34)$$

Where:

$Q_{ventilation}$ [W]: heat loss/gain due to ventilation.

N [1/h]: air change rate = (air change rate due to infiltration + air change rate due to ventilation). Where, infiltration rate is assumed approximately in the lecture room (no occupancy) to be around 0.2 1/h.

V_{indoor} [m³]: indoor space volume.

$c_{p\ air}$ [J/kg.K]: specific heat capacity of air.

$T_{outdoor}$ [K]: outdoor temperature.

T_{indoor} [K]: indoor temperature.

Equation (34) can be simulated by using MATLAB/SIMULINK as shown in Figure 31.

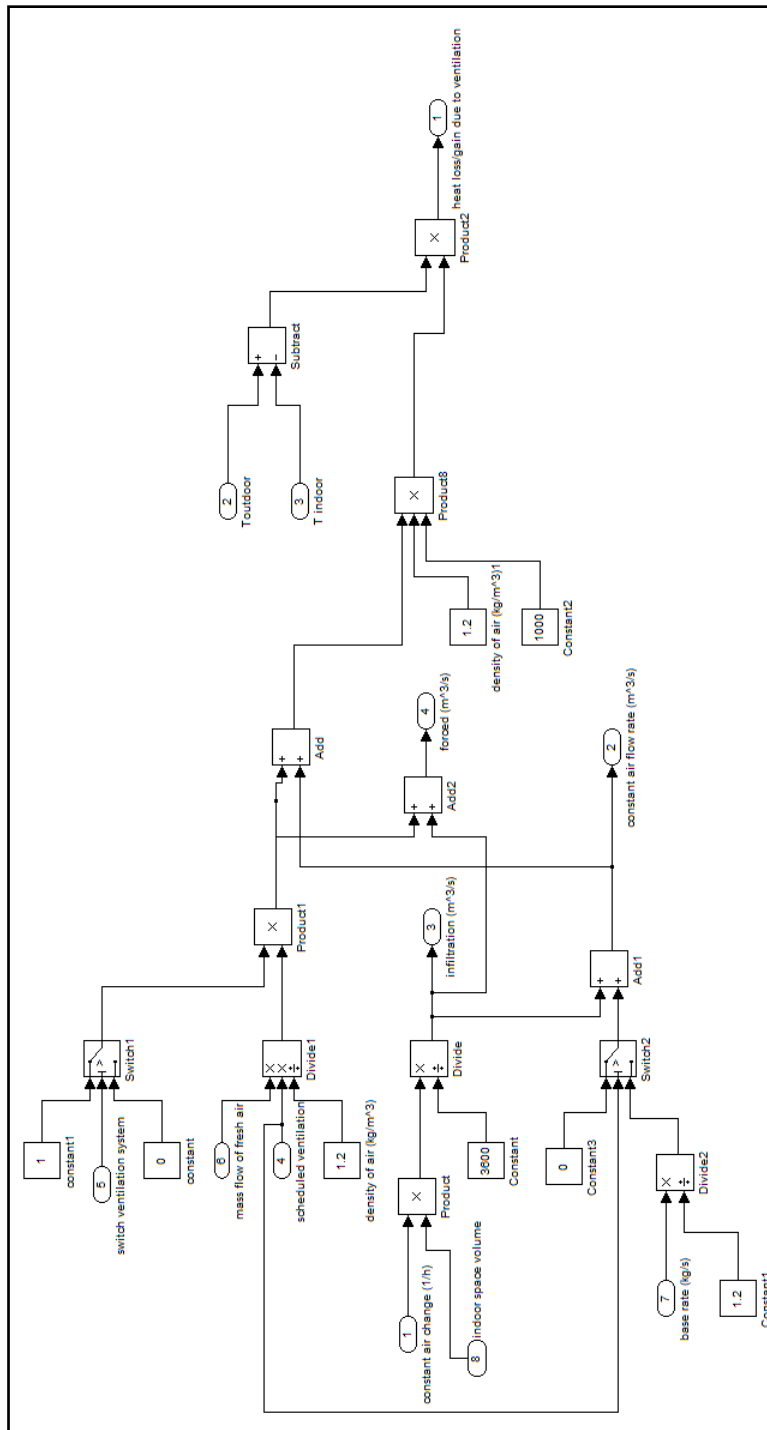

Figure 31: Model of heat loss/gain due to ventilation

4.2.6 Model of internal gains

The conversion of chemical or electrical energy to thermal energy in a building constitutes the internal heat gain or internal load of a building. The primary sources of internal heat gain are people, lights, appliances, and miscellaneous equipment such as computers, printers, and copiers. The average amount of heat given off by a person depends on the level of activity. Typical rates of heat dissipation by people are given in Table 6.

Table 6: Heat gain from people in conditioned spaces (from ASHRAE Handbook of Fundamentals, Chap. 26, Table 3)

Degree of activity	Typical application	Sensible heat, [W]
Seated at theater	Theater—matinee	65
Seated at theater, night	Theater—evening	70
Seated, very light work	Offices, hotels, apartments	70
Moderately active office work	Offices, hotels, apartments	75
Standing, light work; walking	Department or retail store	75
Walking, standing	Drug store, bank	75
Sedentary work	Restaurant	80
Light bench work	Factory	80
Moderate dancing	Dance hall	90
Walking 4.8 km/h (3 mph); light machine work	Factory	110
Bowling	Bowling alley	170
Heavy work	Factory	170
Heavy machine work; lifting	Factory	185
Athletics	Gymnasium	210

Hence, *total internal gains=constant gains (no occupancy), if any + scheduled gains (occupancy), if any + heat gain from people, if any*, as shown in Figure 32.

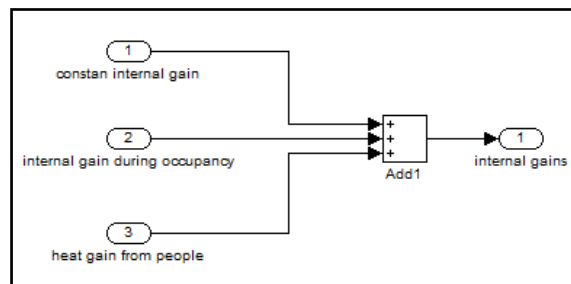

Figure 32: Model of internal gains

4.3 Control strategy

The control is the way of starting, stopping and regulation of HVAC system as well as the tool can make equipment work effectively, and sometimes gives the ability to change their actions over time, while conditions and occupancies may change. Controls are equipment have the ability to monitor the inputs and regulate the output of systems. Controlling of HVAC system includes measuring the variables and obtaining data, as well as process the data with other information, then cause a control action.

The aim of HVAC system and its controls is to provide a comfortable environment for the occupants indoors in order to create a more productive atmosphere. The process is also so important for manufacturing processes with special requirements to ensure a quality product, or it may be a laboratory or hospital operating suite. HVAC system controls and regulates the movement of air and water, as well as heating, cooling, humidification and dehumidification, and must manage the energy. It means that in addition to providing and regulating the functions of HVAC systems, those functions should be done in the most efficient use of energy.

Controllers are usually represented by equations that should be achieved in every simulation step. The controllers must have the ability to control the interaction between building and system as well as interactions between components of the system.

The closed loop control includes a sensor which samples a measurable variable. Based on the set point value and measured value, and according to the control algorithm, the controller calculates the control signal that feeds the actuator.

ON-OFF controller has been used to control indoor temperature, so that it works as controller for heating process in the direct direction of control signal, as follows:

If: $T_{set} - T_{indoor}$ is out of allowed interval, thus $Q_{heating/cooling} = \dot{m} \cdot c_p \cdot (T_{heater/cooler} - T_{indoor})$ will be provided to the classroom until the difference $(T_{set} - T_{indoor})$ return to the allowed interval.

On the other hand, after reversing of control signal, the controller controls the cooling process, as follows: In the direct direction, the difference $(T_{set} - T_{indoor})$ for cooling process is negative because $T_{set} < T_{indoor}$, so relay must work as follows: (switch on point) is (-value) not (+value), and (switch off point) is (+value) not (-value). That means: if $T_{set} - T_{indoor} = -value$, relay will send signal to switch cooling on. Conversely: if $T_{set} - T_{indoor} = +value$, relay will send signal to switch cooling off. Hence, signal relay should be inversed. That means when relay signal is 1, cooling process is off. When Relay signal is 0, cooling process is on. This process can be achieved as follows: When Relay signal is (1), control signal in direct direction is (1), and it is controlling heating process, while the reversed signal is (0), so there is no controlling of cooling process. While, when Relay signal is (0), control signal in direct direction is (0), so there is no controlling of heating process, while reversed signal is (1), and it is controlling cooling process.

Where, the control signal in the process of heating and cooling begins only when the temperature indoor after supplying of air from the air conditioning system without heating or cooling, is out of the allowed range of temperature indoor, as shown in Figure 33.

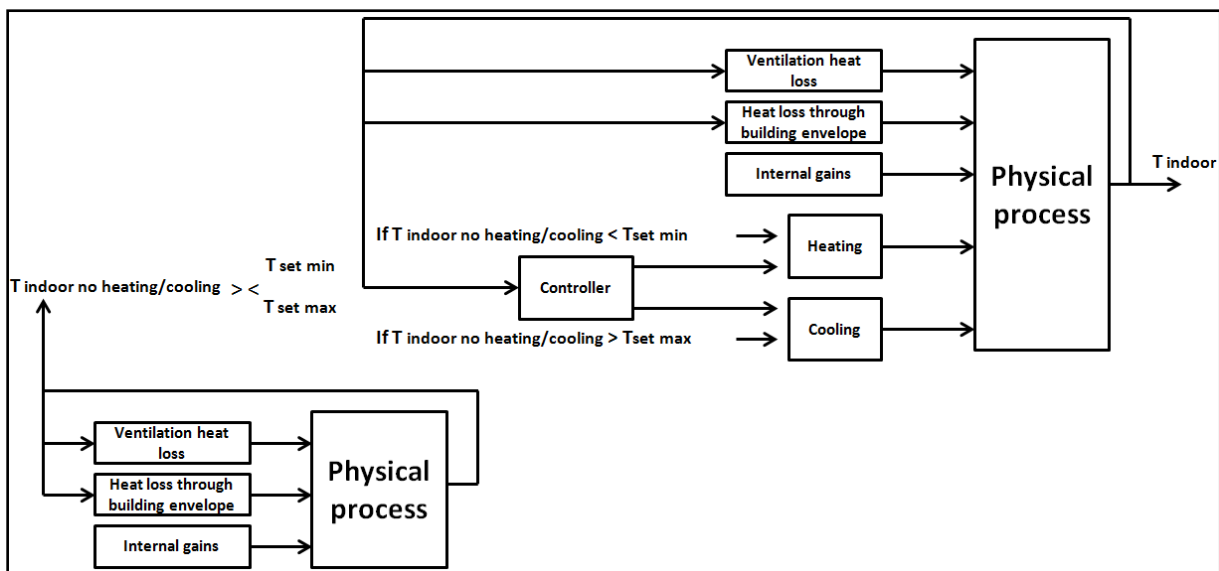

Figure 33: Temperature control strategy

This strategy can be simulated by MATALB/SIMULINK, as shown in Figure 34.

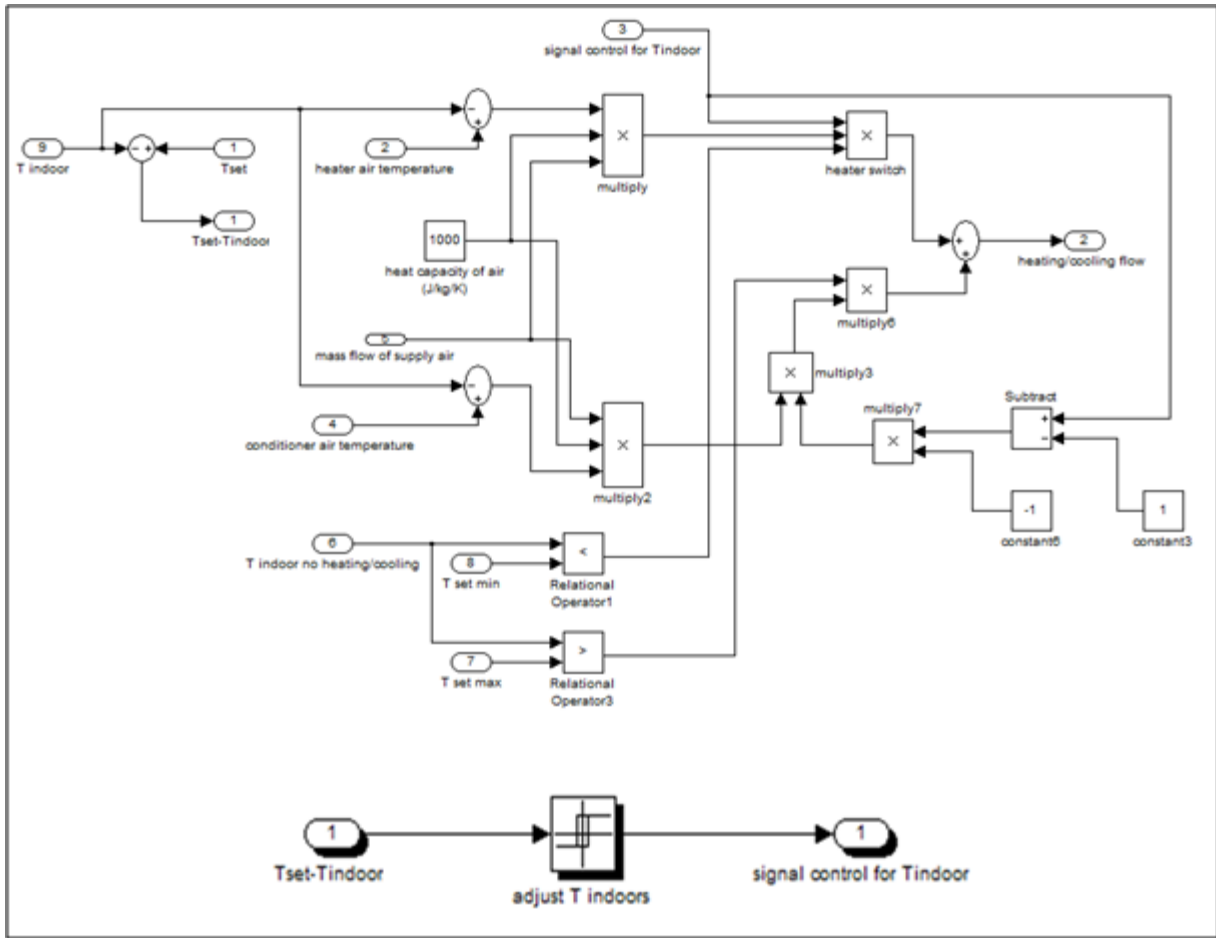

Figure 34: Control strategy model

After calculating all quantities on the right side of equation (20), indoor temperature can be calculated by rearranging equation (19) as follows: shown in Figure 35.

$$T_{indoor} = \int \frac{Q_{ventilation} + Q_{envelopes} + Q_{windows} + Q_{gains}}{\rho_{air} \cdot c_{p_{air}} \cdot V_{air}} \quad (35)$$

Equation (35) can be simulated by using MATLAB/SIMULINK, as shown in Figure 35.

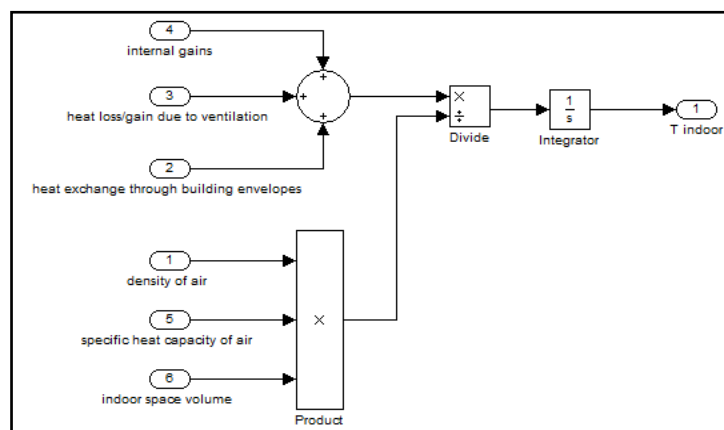

Figure 35: Indoor temperature model

4.4 Calculate heat removed/added

To control temperature inside the classroom, a certain amount of heat must be added or removed. But, considering that the indoor temperature is changing depending on the changing in outdoor temperature, as well as the changing in internal gains, controllers must be used to keep indoor temperature within the allowed range.

The amount of added heat must be greater than a minimum value, so that heating leads to achieving the minimum temperature in the allowed range, as shown in Figure 36.

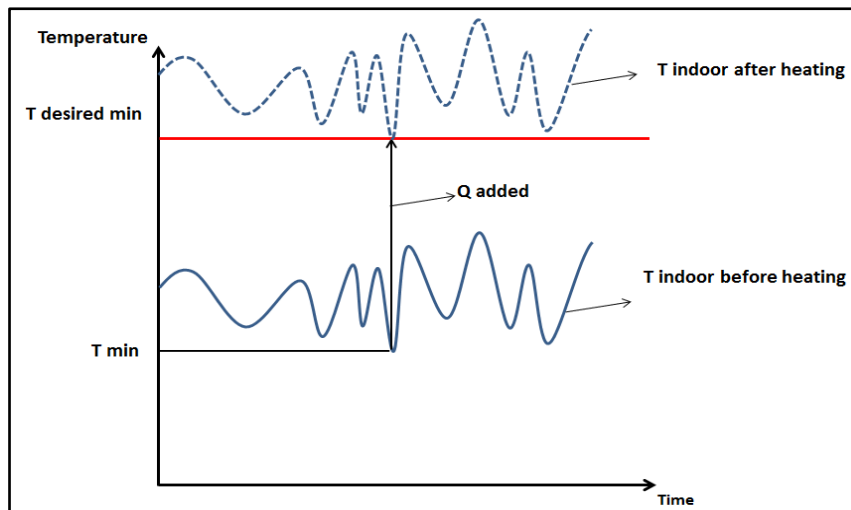

Figure 36: Added heat

It is necessary to calculate the minimum indoor heat gain ($Q_{sumheatmin}$), in order to determine the extreme conditions indoors in winter (the allowed coldest indoor temperature), then based on these conditions, the maximum heat load needed to be supplied to the indoor space can be calculated.

Where $Q_{sumheatmin}$ is the minimum value of the following sum:

(ventilation heat exchange if $T_{indoor}=T_{set, min}$) + (heat exchange through the building envelope if $T_{indoor}=T_{set, min}$) + (internal heat gains)

This value represents the extreme conditions allowed indoors in winter, where there should be a maximum supplying of heat.

There is a specific range, where, within it, indoor temperature can change without the need for any supplying or removing heat to/from indoor space. Hence, the minimum value in this range is called $T_{set, min}$, while the maximum value in this range is called $T_{set, max}$.

For example, If the average temperature inside is 21 °C, it can be assumed, for example, that there is no control signal as long as the indoor temperature is between 19 °C and 23 °C.

Where here: $T_{set, min}=19$ °C, while $T_{set, max}=23$ °C.

Hence, the minimum heat indoor without heating must be calculated, as follows:

$Q_{sumheatmin} = \text{Min (ventilation heat Min + heat through the building envelope Min + internal heat gain)}$

Where: *ventilation heat Min* can be calculated as follows:

$$\text{Ventilation heat Min} = \frac{N \cdot \rho_{air} \cdot V_{indoor} \cdot c_{pair}}{3600} (T_{outdoor} - T_{set\ min}) \quad (36)$$

While, *heat through the building envelope Min = heat exchange through building envelope if $T_{indoor}=T_{set, min}$.*

Where: $T_{set,min}$ is the minimum allowed indoor temperature. Hence, conditioner temperature (supply air temperature) can be calculated as follows:

$$T_{conditioner} = T_{set\ min} - \frac{Q_{sumheatmin}}{m \cdot c_{p\ air}} \quad (37)$$

Where:

m [kg/s]: mass flow of supply air.

c_{pair} [J/kg.K]: specific heat capacity of supply air.

On the other hand, the amount of removed heat must be greater than a minimum value, so that cooling leads to achieving the maximum temperature in the allowed range, as shown in Figure 37.

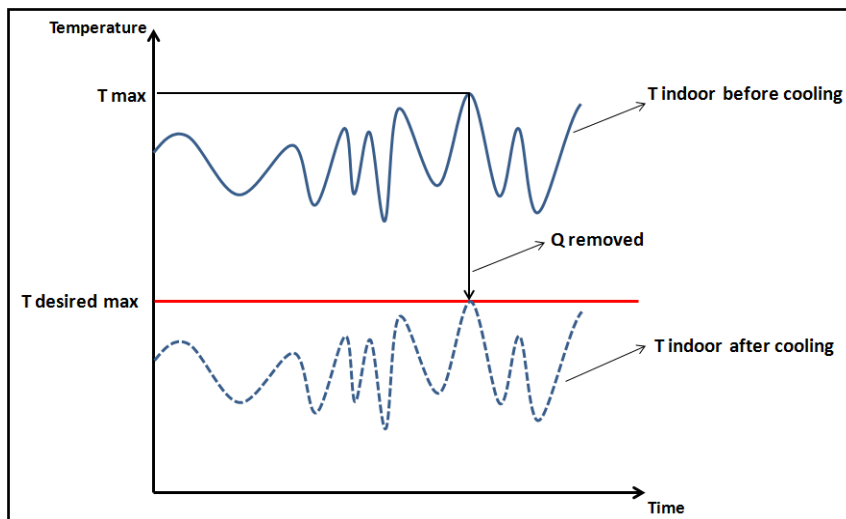

Figure 37: Removed heat

It is necessary to calculate the maximum indoor heat gain ($Q_{sumheatmax}$), in order to determine the extreme conditions indoors in summer (the allowed hottest indoor temperature), then based on these conditions, the maximum heat load needed to be removed from the indoor space can be calculated.

Where $Q_{sumheatmax}$ is the maximum value of the following sum:

(ventilation heat exchange if $T_{indoor}=T_{set, max}$) + (heat exchange through the building envelope if $T_{indoor}=T_{set, max}$) + (internal heat gains)

This value represents the extreme conditions allowed indoors in summer, where there should be a maximum removing of heat.

So, the maximum heat indoor without cooling must be calculated, as follows:

$Q_{sumheatmax} = \text{Max (ventilation heat Max + heat through the building envelope Max + internal heat gain)}$

Where: *ventilation heat Max* can be calculated as follows:

$$\text{Ventilation heat Max} = \frac{N \cdot \rho_{air} \cdot V_{indoor} \cdot c_{pair}}{3600} (T_{outdoor} - T_{set,max}) \quad (38)$$

While, *heat through the building envelope Max = heat exchange through building envelope if*
 $T_{indoor} = T_{set,max}$

Where: $T_{set,max}$ is the maximum allowed indoor temperature. Hence, conditioner temperature (supply air temperature) can be calculated as follows:

$$T_{conditioner} = T_{set,max} - \frac{Q_{sumheatmax}}{m \cdot c_{pair}} \quad (39)$$

5 MODELLING CO₂ CNCENTRATION INDOORS

5.1 Background

It is important to monitor indoor air quality (IAQ) to maintain health conditions indoor and to create appropriate conditions for achieving the required productivity at work. Process of bringing outside air to inside building to remove contaminants present in the air affects too much indoor air quality, but at the same time, is an expensive process, because outside air must be conditioned before being sent into the building. Ventilation based on concentration of carbon dioxide indoor (demand-controlled ventilation, or DCV) has been suggested to maintain the required air quality at the lowest possible cost. This strategy controls outside air brought to the building based on indoor CO₂ concentration. As a result, the building will not be under-ventilated, i.e. poor indoor air quality, nor over -ventilated, i.e. waste of energy.

Mechanical ventilation systems affect significantly the indoor air quality. On the other hand, are of the most energy consumers in the world. Most ventilation systems receive specific amounts of outside air, depending on a pre-defined value which is usually the maximum occupancy. This way causes unnecessary costs, because the actual size of occupancy in most buildings does not reach the maximum level, thus no need to deliver all those amounts of outside air, where, they must be conditioned before being sent into the building. This is what will lead to a waste of energy.

CO₂ production has been suggested to be as indicator for general occupancy activities indoors. Hence, indoor CO₂ concentration can be used with outside air in order to control ventilation rate which must be used in the building. It means that the buildings have a way to control outside air in real time which will be used as a ventilation rate, instead of relying on arbitrary amounts of outside air.

CO₂ control technology provides the ability to measure and control outside air delivered to the indoor space based on the actual ventilation rate required, which is determined by monitoring indoor CO₂ concentration.

The energy required for air-conditioning process can be reduced by combining ventilation rate with the number of occupants in the building over time, where, the process of air-conditioning by this strategy will be applied for proper amounts of outside air, not arbitrary amounts. This way is called (demand-controlled ventilation), or (DCV). This strategy operates based on measuring indoor CO₂ concentration by using a sensor, and generating a feedback signal to control the ventilation rate in order to maintain an acceptable indoor air quality by using the minimum amount of outside air. Hence, demand-controlled ventilation saves energy in buildings by reducing unnecessary amount of delivered air resulting from inappropriate ventilation rate.

(DCV) strategy provides the required quality of indoor air and offers an effective solution to save energy better than traditional ventilation strategy. Many searches have shown significant potential for energy savings ([52] [53]), particularly in buildings or spaces with a high and variable occupancy. Based on modelling [54], cooling energy savings by using demand controlled ventilation are up to 20 %. Actual savings that can be achieved by using (DCV) strategy depend on many factors such as usage, actual occupancy, building construction and equipment. The maximum savings that can be achieved are in facilities with continuously change in occupancy, such as theatres, classrooms and hotels.

5.2 Mass balance model of indoor carbon dioxide

Conservation of mass forms the basis to model the dynamic change in CO₂ concentration. Then simulation of this process on software SIMULINK/MATLAB helps to provide the necessary environment to propose control strategies in order to adjust CO₂ concentration in accordance with the requirements of the occupants.

The mass balance of indoor CO₂ concentrations for the steady state can be determined for the ventilation rate used by the equation [55].

$$V_{indoor} \frac{dC_{in}}{dt} = G + Q_v C_{out} - Q_v C_{in} \quad (40)$$

Where:

V_{indoor} [m³]: indoor space volume.

C_{in} [ppm]: indoor CO₂ concentration.

C_{out} [ppm]: outdoor CO₂ concentration.

t [s]: time.

G [m³/s]: indoor CO₂ generation rate.

Q_v [m³/s]: ventilation rate.

When students enter to the classroom, indoor CO₂ concentration will begin to increase until the amounts of CO₂ resulted from the students and amounts present within the air delivered from ventilation system to the space become in balance state. This state is called the equilibrium point. At this case, there is no change in CO₂ concentration:

$$V_{indoor} \frac{dC_{in}}{dt} = 0 \quad (41)$$

Then, equation (40) can be written as follows:

$$Q_v C_{in} = G + Q_v C_{out} \quad (42)$$

Figure 38 represents the balance expressed by the relation (42).

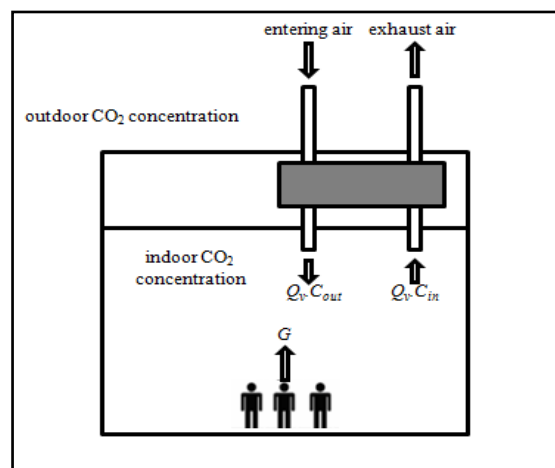

Figure 38: CO₂ indoors mass balance

By rearranging equation (40):

$$C_{in} = \int \frac{G + Q_v C_{out} - Q_v C_{in}}{V_{indoor}} dt \quad (43)$$

Equation (43) can be simulated using SIMULINK/MATLAB. This is the basic process simulation.

As shown in Figure 39 that (switch 1) allows signal of value (1) to pass only if there is occupancy. It means there is CO₂ generated from people indoors. In contrast, if there is no occupancy, (switch 1) allows signal of value (0) to pass. It means there is no CO₂ generated from people indoors. As shown that output of model is multiplied in 10⁻⁶ so that CO₂ indoor obtained in ppm. Forced ventilation rate value can be controlled according to the ventilation strategy used, where, two of these strategies have been discussed: traditional base/forced ventilation, and demand-controlled ventilation (DCV).

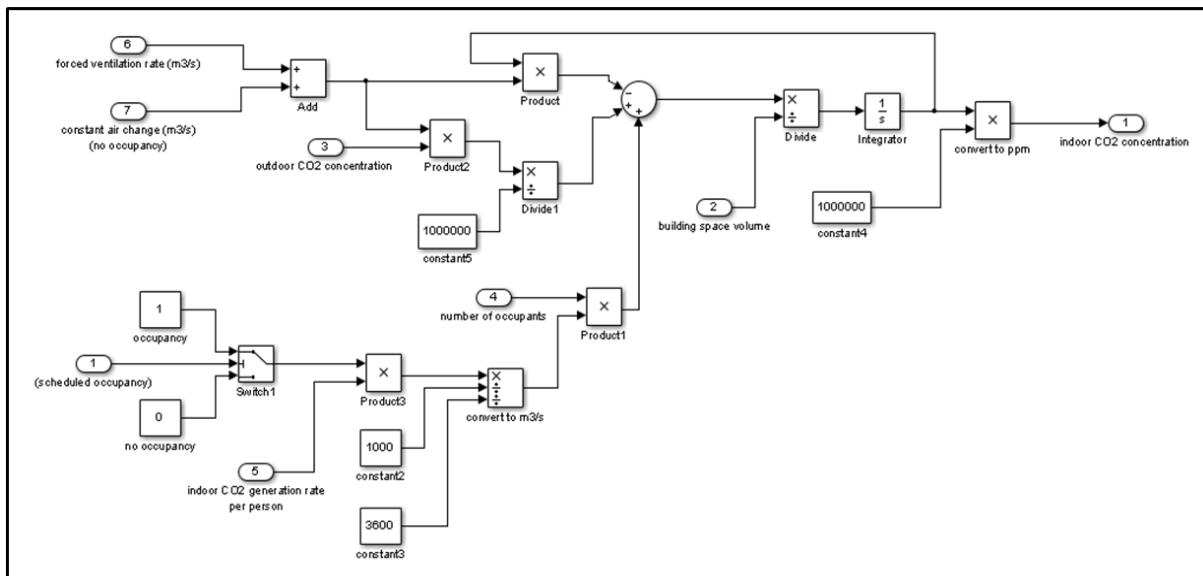

Figure 39: Mass balance model of indoor CO₂ concentration

5.3 Traditional base/forced ventilation model

Traditional base/forced strategy operates according to the existence of occupancy, so that when there is occupancy, forced ventilation will be used regardless of occupancy size, while base ventilation is used only when there is no occupancy. Hence, the criterion in this strategy is not the occupancy size, but it is the existence of occupancy. This strategy means if there is occupancy, the ventilation rate is the forced rate. On the other hand, when there is no occupancy, the ventilation rate is the base rate.

As shown in Figure 40, the model has been designed so that when there is occupancy, the signal passing through switch (1) is 1. In this case, the signal passing through switch (2) is the forced rate. As long as there is occupancy, the ventilation rate is the forced rate. On the other hand, when there is no occupancy, the signal passing through switch (1) is 0. In this case, the signal passing through switch (2) is the constant rate.

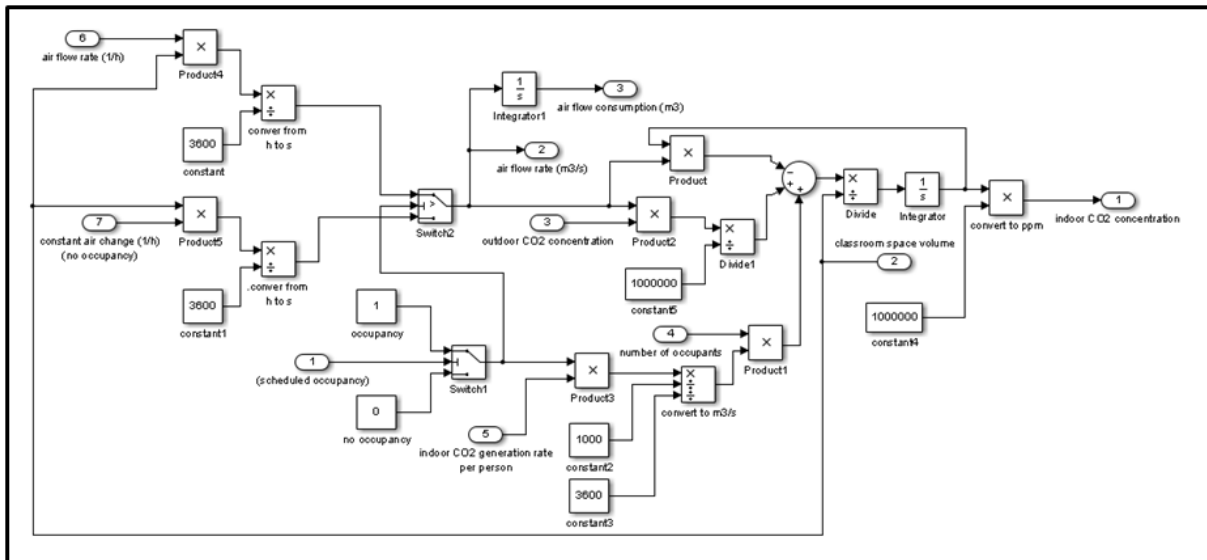

Figure 40: Traditional base/forced ventilation model

5.4 Demand controlled ventilation (DCV) model

To save energy, HVAC control system uses CO₂ concentration to automatically change the ventilation rate so that indoor CO₂ concentration remains at or below a maximum level. (DCV) strategy controls the ventilation rate according to the building occupancy (CO₂ concentration resulted from occupants). By this way, if the building is only 60% full, then only 60% of the design-rate ventilation air will be used, not 100% as is used in traditional mechanical ventilation systems.

CO₂ sensors are the technology available to operate (DCV) strategy. Sensors continuously measure indoor CO₂ concentration. Then based on measuring, the ventilation rate is modified when indoor CO₂ concentration reaches a pre-defined level. This level represents differential between indoor and outdoor CO₂ concentration.

The average of target indoor CO₂ concentration (set point) used in the model is 800 ppm. This strategy has been applied by using ON-OFF controller which operates as follows: When the differential between indoor CO₂ concentration measured and set point is in the range [-50→50], there is no signal control. In this case, switch (2) allows only the constant rate to pass, as shown in Figure 41. On the other hand, when the differential between indoor CO₂ concentration measured and set point exceeds this range, there will be a feedback signal. In this case, switch (2) allows the forced rate to pass until the differential becomes again within the range.

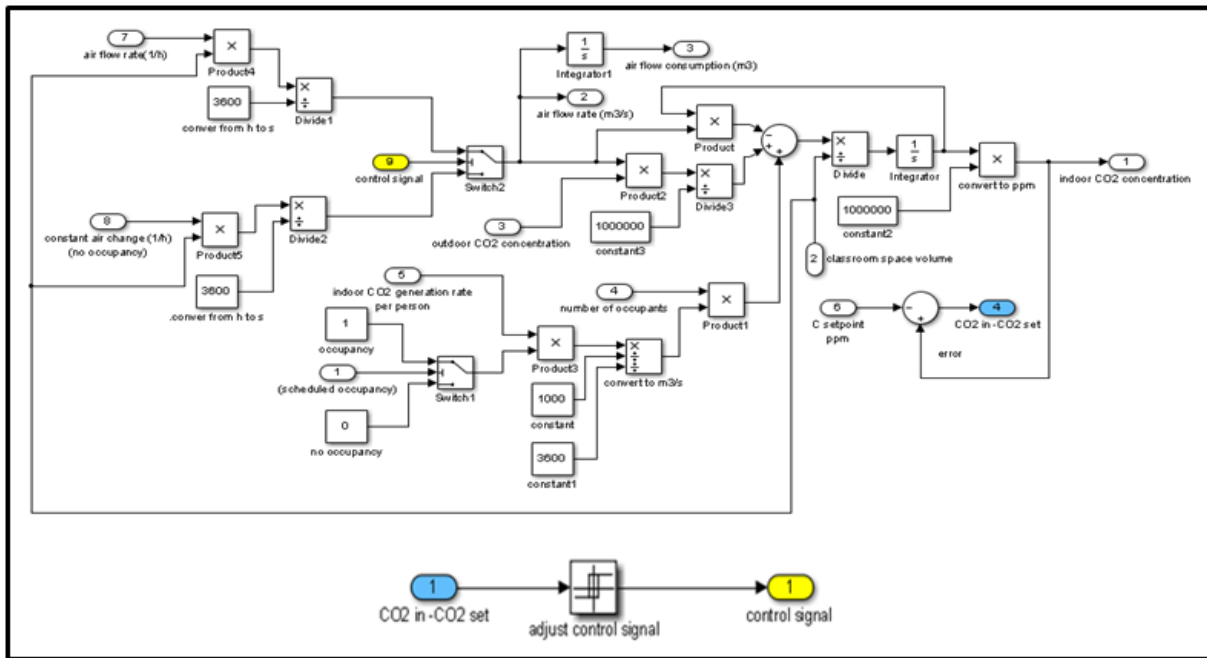

Figure 41: Demand controlled ventilation (DCV) with ON-OFF controller

Scheduled occupancy is simulated as shown in Figure 42.

Where:

Phase represents the time before occupancy.

Period represents the whole day (24 hours).

Amplitude = 1.

Width represents the occupancy period.

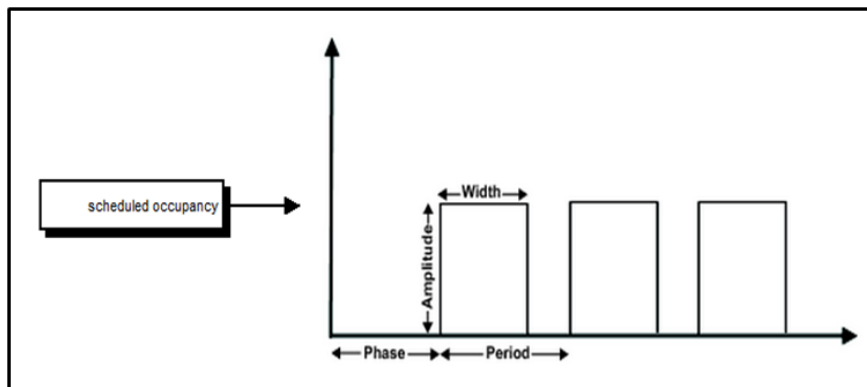

Figure 42: Scheduled occupancy model

The comparing between air consumptions shows that (DCV) strategy operates according to the occupancy size (indoor CO₂ concentration), not just according to the existence of occupancy, as it is in base/forced strategy. This leads to savings in air consumption. Where, percentage of savings can be calculated as follows:

Percentage of savings = (air flow consumption for traditional strategy - air flow consumption for DCV strategy) / air flow consumption for traditional strategy

Hence, it is possible to calculate the amount of savings in energy consumption when using (DCV) strategy. By the imposition that amount of air savings must be heated or cooled by the different between indoor and outdoor temperatures during winter or summer, respectively, the energy needed for this process can be calculated as follows [56]:

$$E = \rho_{air} \cdot c_{p,air} \cdot V_{air} \cdot |\Delta T| \quad (44)$$

Where:

E [J]: heat (energy).

ρ_{air} [kg/m³]: density of air.

$c_{p,air}$ [J/kg.K]: specific heat capacity of the air

V_{air} [m³]: air volume.

$|\Delta T|$: the difference between indoor and outdoor temperatures in absolute value.

These amounts of savings can be simulated on MATABL/SIMULINK as shown in Figure 43.

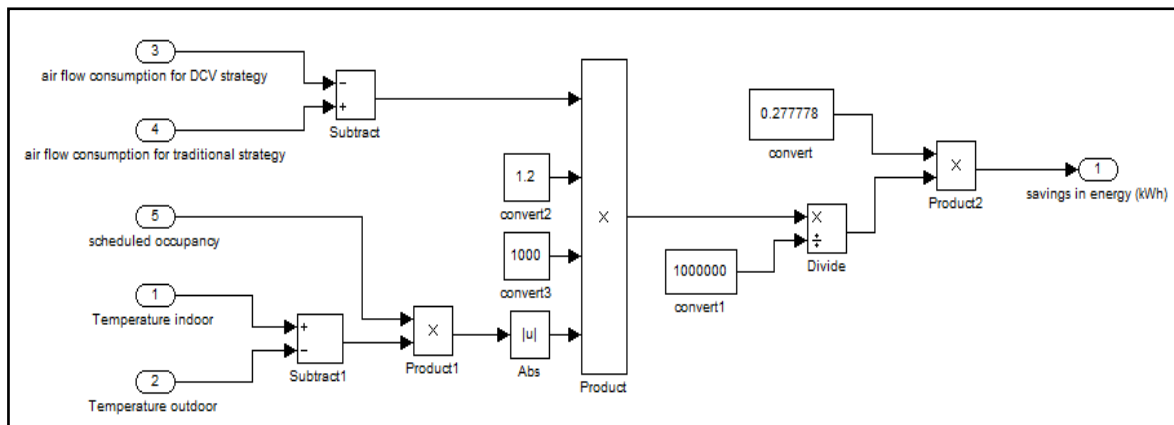

Figure 43: Savings model

6 MODELLING HUMIDITY INDOORS

6.1 Background

The general understanding of the concept of good control of the thermal environment is only to control the indoor temperature, but there are still a lot of people within this environment suffering from nose irritations, eye irritations, cough, fatigue, headache and skin irritations. Such symptoms are called sick building syndrome (SBS), which are affected by relative humidity indoors [17], because humidity affects the rate of evaporation of water in the air, and the balance of energy within the body, as well as thermal comfort for the occupants [57].

According to research on epidemiology, the relative humidity has a direct effect on cell membranes associated with respiratory, nose tissue inflammations or influenza and fever. It also has an indirect effect on the growth of allergies and respiratory diseases, bacteria and viruses [58]. Relative humidity also affects the severity of chemical pollution in the air by changing the distribution rate of gas from the materials used inside the buildings and the reaction between water and chemicals in the air [17].

Recent studies show that the increasing in humidity can reduce the inflammatory tissue of the nose. It has been found that the increasing in humidity can reduce the irritation of the nose of the 4 people of sample group of 22 people [59].

Low humidity is related to a tissue weakness [60]. While other studies [61] show that an appropriate increasing in humidity is useful to reduce various diseases and respiratory diseases.

Under certain temperature and a level of moisture content, mould can grow on the surfaces of some parts of the building, where, germs may cause health risks, even fatal to the occupants ([62], [63]).

Maintain moisture contents inside the building elements within safe levels and avoid the accumulation of moisture is critical to the durability of the building envelope, and should be carefully considered in the design of the building components and material used.

To understand the performance of the humidity within the building is necessary to know the theory of heat and mass transfer, as well as measurement of material properties, data collection and analysis of loads.

Building envelope separates between the indoor space and outdoor surroundings, where, it has multi layers components to control transfer of heat, air, moisture, noise and light. The indoor sources of moisture are basically the humidity resulted from the occupants and their behaviours, for example: manufacture process in industrial buildings, as well as cooking and washing for residential buildings, etc. While the outdoor sources are the humid air, precipitation in the forms of rain or snow, and ground water. The outdoor moisture from direct rain penetration, is a contributing factor in 91% of moisture-related problems [64], where by wind pressure, rain drops can pass through the joints and cracks, and result in partial or thorough penetration of the building envelope.

HAM, for Heat, Air and Moisture transport, is a building simulation program that provides one-dimensional calculations of heat, air and moisture transport processes in a building enclosure. Moisture is transferred by diffusion and convection in vapour phase. No liquid water transport is considered. HAM was initiated in the European Union and sponsored by IEA-Annex 24. It is has developed as part of HAM-Tools, an integrated simulation tool for heat, air and moisture analyses for whole buildings [65].

With the development of numerical computation techniques, the coupled heat and mass transport in building envelopes can be expressed as partial differential equations which can be calculated more accurately and efficiently. One approach to develop hygrothermal tools emerged which made use of environments of commercial engineering software, in particular MATLAB/SIMULINK, such as International Building Physics Toolbox (IBPT or HAM-tool) [66] and HAMLab [67]. The development of International Building Physics Toolbox (IBPT or HAM-tool) applied MATLAB/SIMULINK to generate modular blocks to represent various components, such as building envelopes, indoor climate, HVAC, and climate.

6.2 Relative humidity model

Moisture balance in the conditioned indoor space is shown in Figure 44.

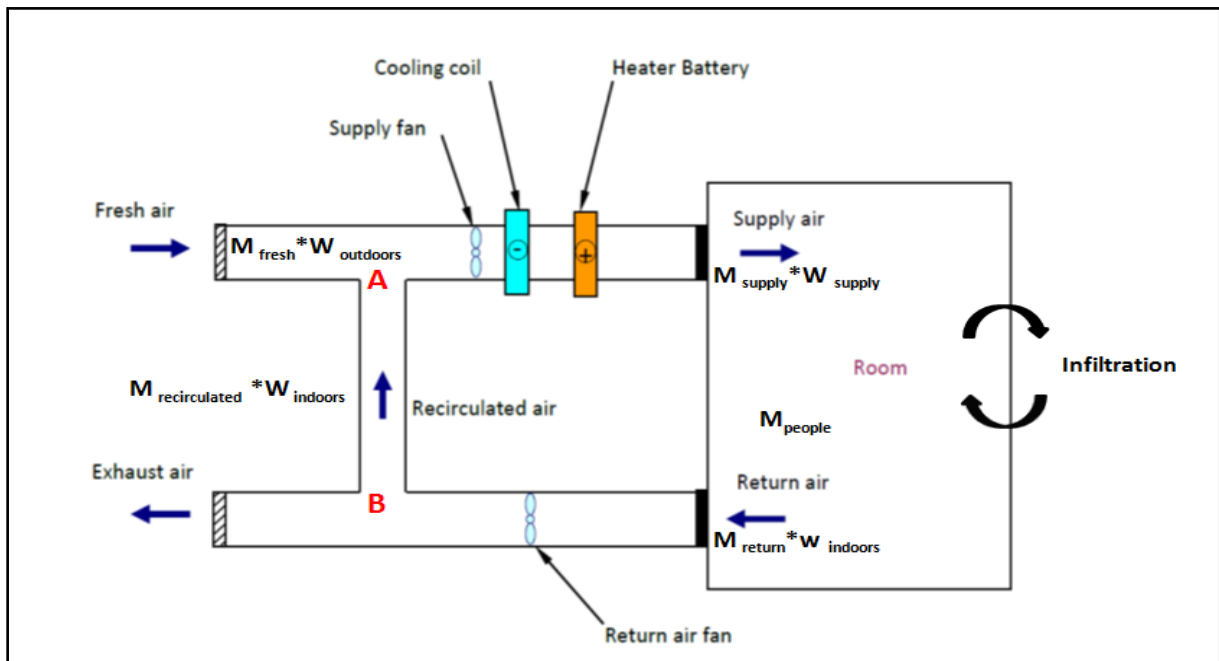

Figure 44: Schematic diagram of moisture balance in the conditioned room

The balance can be expressed by the relation [68]:

$$M_{supply} \cdot W_{supply} - M_{return} \cdot W_{indoors} + M_{infiltration} \cdot W_{outdoors} - M_{infiltration} \cdot W_{indoors} + M_{people} + M_{added/removed} = \rho_{air} V_{indoor} \frac{dW_{indoors}}{dt} \quad (45)$$

Where:

M_{supply} [kg/s]: mass flow of supply air.

W_{supply} [kg/kg]: specific humidity of supply air.

M_{return} [kg/s]: mass flow of return air.

$W_{indoors}$ [kg/kg]: specific humidity of air in the room.

$M_{infiltration}$ [kg/s]: mass flow of infiltration air.

$W_{outdoors}$ [kg/kg]: specific humidity of air outdoors.

M_{people} [kg/s]: moisture generated from people, normally is (0.01157/1000 kg/s per person) [69].

$M_{added/removed}$ [kg/s]: moisture generated by conditioning.

Depending on the mass balance at point **A**:

$$M_{supply} \cdot W_{supply} = M_{fresh} \cdot W_{outdoors} + M_{recirculated} \cdot W_{indoors} \quad (46)$$

Depending on the mass balance of air at point **B**:

$$M_{return} = M_{fresh} + M_{recirculated} \quad (47)$$

Where:

M_{fresh} [kg/s]: mass flow of fresh air.

$M_{recirculated}$ [kg/s]: mass flow of recirculated air.

By substitution equations (46) and (47) in equation (45):

$$W_{indoors} = \int \frac{(M_{fresh} + M_{infiltration}) \cdot (W_{outdoors} - W_{indoors}) + M_{people} + M_{added/removed}}{\rho_{air} \cdot V_{indoor}} \quad (48)$$

Outdoor humidity can be calculated by the relation [70]:

$$W_{outdoors} = \frac{0.622 \cdot RH_{outdoors} \cdot P_{s,outdoors}}{P_{outdoors} - (RH_{outdoors} \cdot P_{s,outdoors})} \quad (49)$$

Equations (48) and (49) can be simulated by using MATLAB/SIMULINK, as shown in Figure 45.

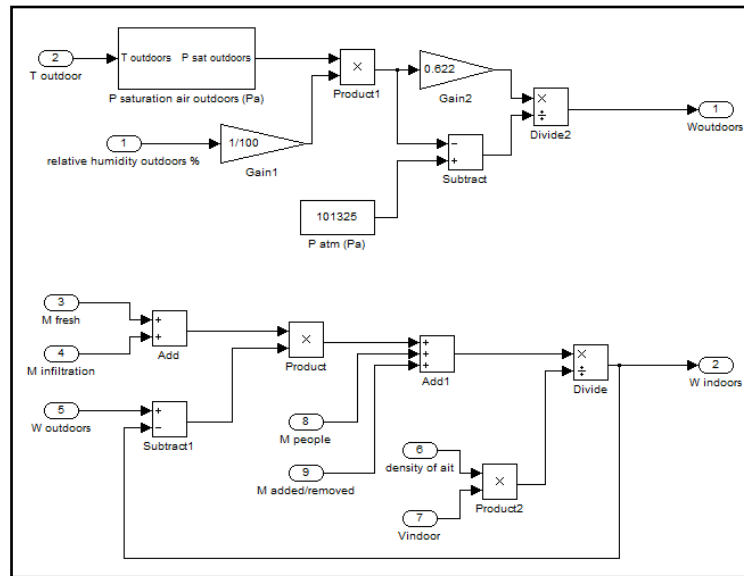

Figure 45: Humidity balance indoors model and humidity outdoor model

After calculating $W_{indoors}$, relative humidity indoors $RH_{indoors}$ can be calculated as follows [70]:

$$RH_{indoors} = \frac{0.622 \cdot W_{indoors} \cdot P_{s,indoors}}{P_{indoors} - (W_{indoors} \cdot P_{s,indoors})} \quad (50)$$

Where:

- a) $P_{s,indoors}$ [Pa]: saturation pressure of air indoors, can be calculated by the equation [71]:

$$P_{s,indoors} = \frac{e^{\left(77.3450 + 0.0057T_{indoor} - \frac{7235}{T_{indoor}}\right)}}{T_{indoor}^{8.2}} \quad (51)$$

Where: T_{indoor} [K]: is temperature of air indoors.

Equation (51) can be simulated by using MATLAB/SIMULINK, as shown in Figure 46.

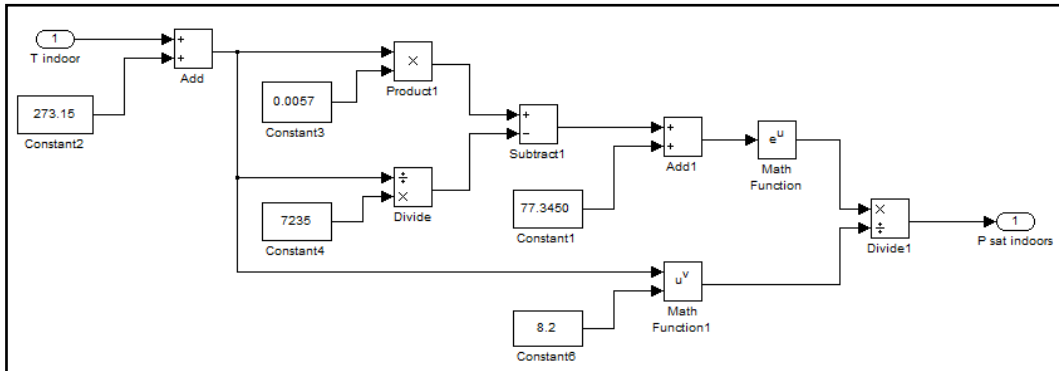

Figure 46: Saturation pressure air indoors model

- b) $P_{indoors}$ [Pa]: pressure air indoors can be calculated by the equation [70]:

$$P_{indoors} = \frac{T_{indoor} \cdot R_{air,indoor} \cdot \dot{m}}{Q_v} \quad (52)$$

Where:

\dot{m} [kg/s]: air mass flow = $M_{supply\ air} + M_{infiltration}$

Q_v [m³/s]: air flow rate = $Q_{v\ supply\ air} + Q_{v\ infiltration}$

$R_{air,indoors}$: gas constant of air indoors = 287 J/kg.K

Equation (52) can be simulated by using MATLAB/SIMULINK, as shown in Figure 47.

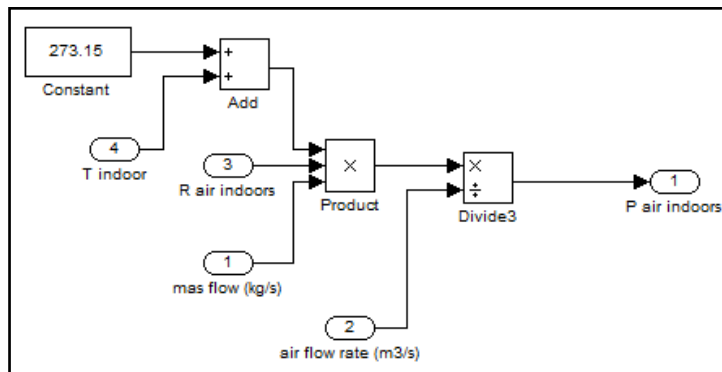

Figure 47: Pressure air indoors model

Then, relative humidity indoors $RH_{indoors}$ can be calculated by the relation [70]:

$$RH_{indoors} = \frac{W_{indoors} \cdot P_{indoors}}{P_{s,indoors} - (W_{indoors} + 0.622)} \quad (53)$$

Equation (53) can be simulated by using MATLAB/SIMULINK, as shown in Figure 48.

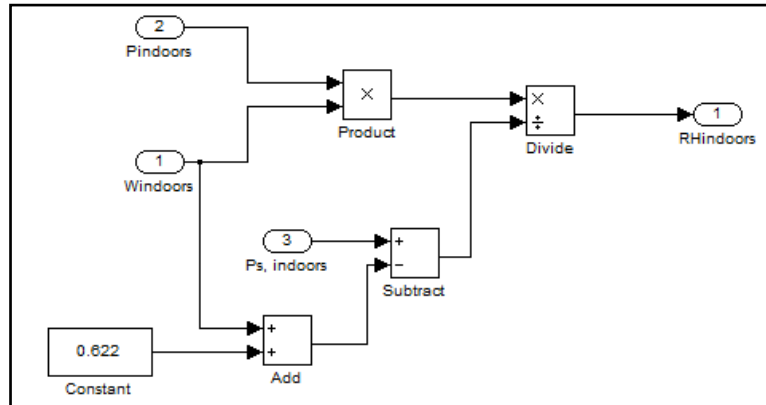

Figure 48: Relative humidity indoors model

6.3 Control humidity model

There is a specific range, where, within it, indoor relative humidity can change without the need for supplying or removing humidity (water) from the indoor space. Hence, the minimum value in this range is called RH_{min} and corresponding humidity is $W_{in(min)}$. While the maximum value in this range is called RH_{max} and corresponding humidity is $W_{in(max)}$. For example, if the average relative humidity inside is 40%, it can be assumed, for example, that there is no control signal as long as the indoor relative humidity is between 30 % and 50 % , where: $RH_{min}=30\%$, while $RH_{max}=50\%$

From equation (48), if assumed that:

$$M_{fresh} + M_{infiltration} = a$$

$$M_{people} = b$$

$$\rho \cdot V = c$$

If not, add or remove water:

$$c \cdot W_{indoors} = \int a \cdot (W_{outdoors} - W_{indoors}) + \int b \quad (54)$$

- If $W_{indoors} < W_{in(min)}$, there must be a process of adding water.

Where:

$$W_{in(min)} = \frac{0.622 \cdot RH_{min} \cdot P_{s,indoors}}{P_{indoors} - (RH_{min} \cdot P_{s,indoors})} \quad (55)$$

Equation (55) can be simulated by using MATLAB/SIMULINK, as shown in Figure 49.

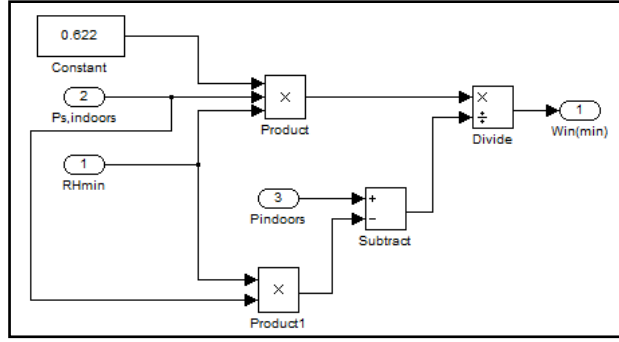

Figure 49: $W_{in(min)}$ model

In this case, equation (54) must become as follows:

$$c.W_{in(min)} = \int a.(W_{outdoors} - W_{in(min)}) + \int b + \int M_{added} \quad (56)$$

- If $W_{indoors} > W_{in(max)}$, there must be a process of removing water.

Where:

$$W_{in(max)} = \frac{0.622.RH_{max}.P_{s,indoors}}{P_{indoors} - (RH_{max}.P_{s,indoors})} \quad (57)$$

Equation (57) can be simulated by using MATLAB/SIMULINK, as shown in Figure 50.

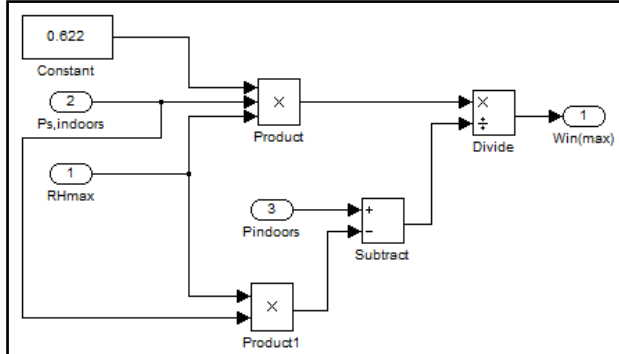

Figure 50: $W_{in(max)}$ model

In this case equation (54) must be as follows:

$$c.W_{in(max)} = \int a.(W_{outdoors} - W_{in(max)}) + \int b - \int M_{removed} \quad (58)$$

By subtracting equation (54) from equation (56):

$$\int M_{added} = c(W_{in(min)} - W_{indoors}) + a \int (W_{in(min)} - W_{indoors}) \quad (59)$$

Equation (59) can be simulated by using MATLAB/SIMULINK, as shown in Figure 51.

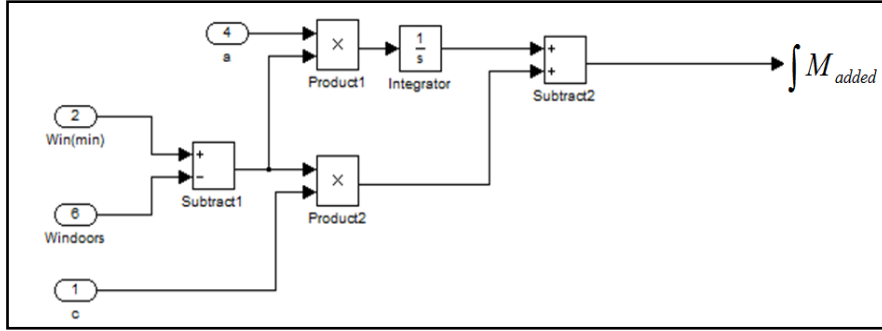

Figure 51: $\int M_{added}$ model

By subtracting equation (54) from equation (58):

$$\int M_{removed} = c(W_{indoors} - W_{in(max)}) + a \int (W_{indoors} - W_{in(max)}) \quad (60)$$

Equation (60) can be simulated by using MATLAB/SIMULINK, as shown in Figure 52.

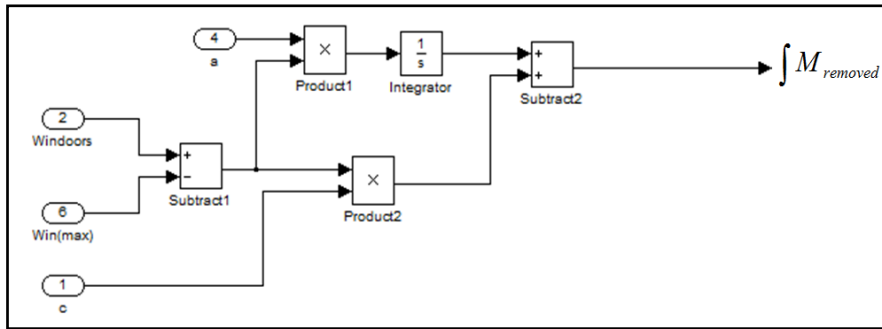

Figure 52: $\int M_{removed}$ model

After calculating $\int M_{added}$ and $\int M_{removed}$, as shown in Figure 53, adding and removing water rates can be calculated as follows:

$M_{added} = \int M_{added} / (\text{time integration of adding water})$, as shown in Figure 54.

Where: time integration of adding water is the interval time where $RH_{indoor} < RH_{min}$.

$M_{removed} = \int M_{removed} / (\text{time integration of removing water})$, as shown in Figure 55.

Where: time integration of removing water is the interval time where $RH_{indoor} > RH_{max}$.

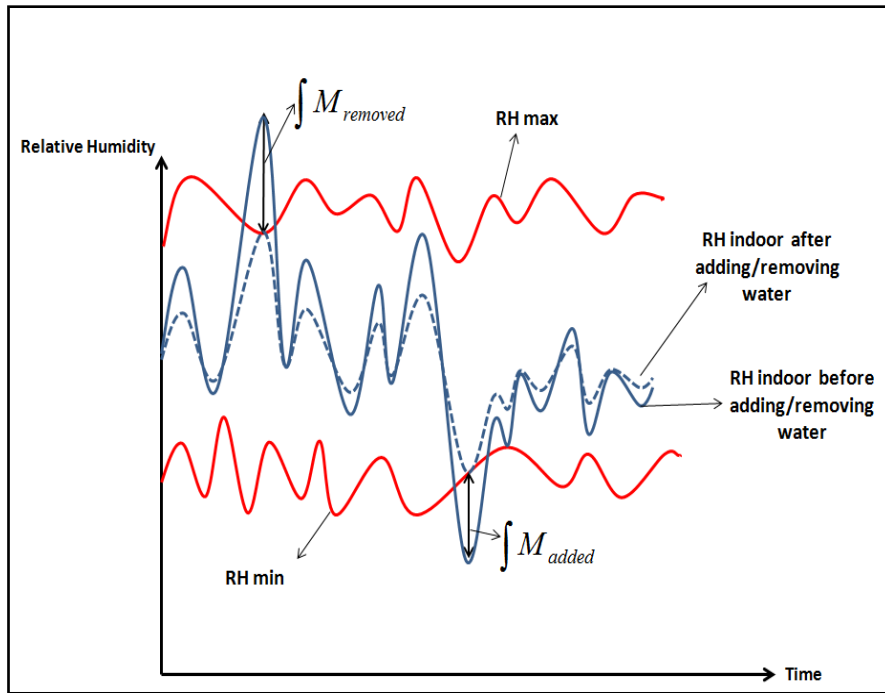

Figure 53: Control of indoor relative humidity

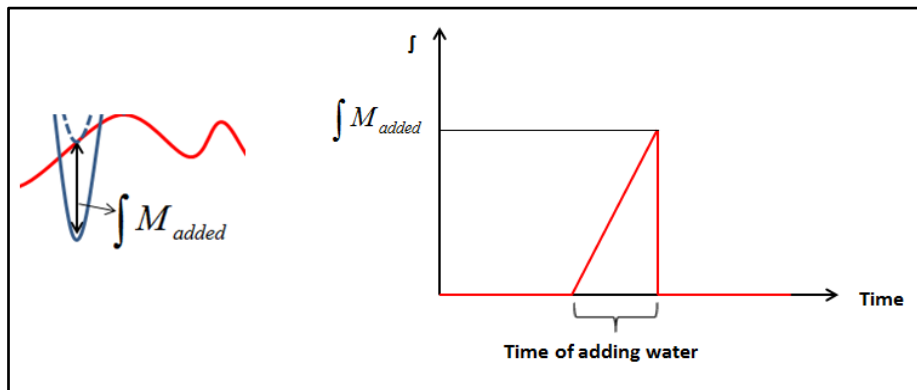

Figure 54: Calculate M_{added}

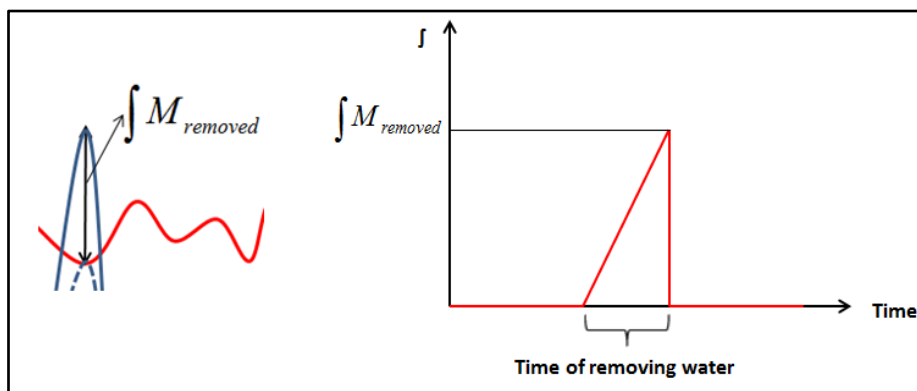

Figure 55: Calculate $M_{removed}$

Control indoor relative humidity $RH_{indoors}$ can be done by the quantity $M_{added/removed}$ which determines the amount of water must be added/removed to/from indoor air, so that maintain the desired indoor relative humidity.

If *relative humidity indoor no conditioning space* < *minimum level*, signal control must be sent so that adding water process begins.

If *relative humidity indoor no conditioning space* > *maximum level*, signal control must be sent so that removing water process begins.

If *maximum level* > *relative humidity no conditioning space* > *minimum level*, there is no signal control.

This strategy is shown in Figure 56.

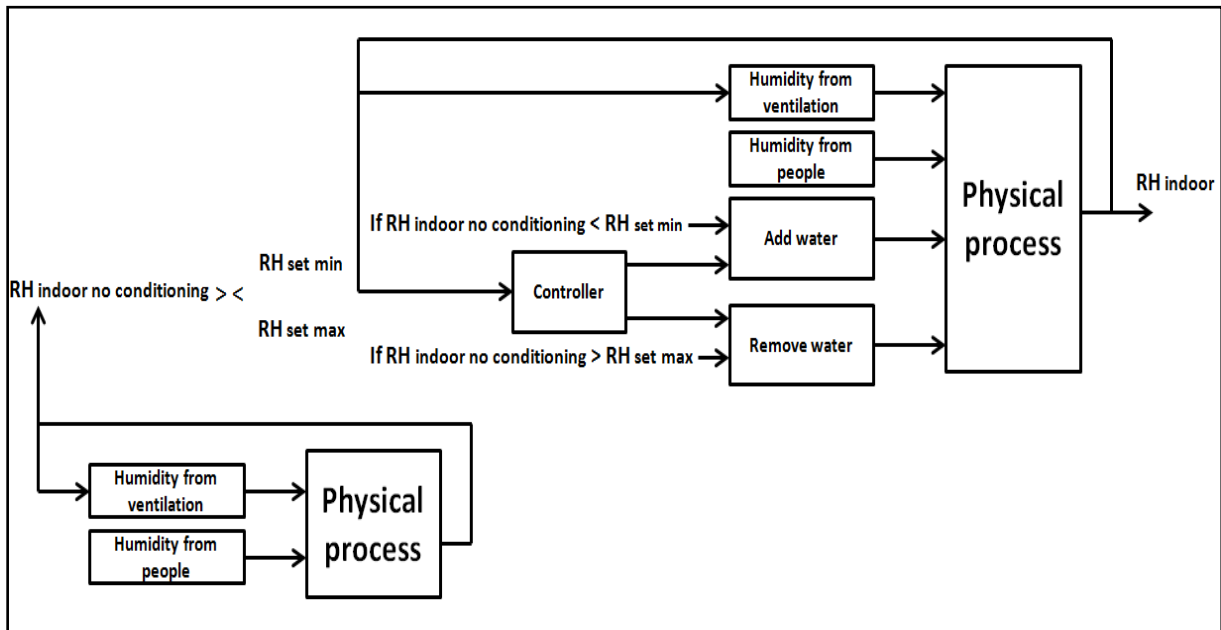

Figure 56: Scheme proposed strategy to control indoor humidity

In order to know whether the rates of added/removed water are correct, the actual indoor humidity content ($W_{indoors}$) must be compared with the maximum and minimum humidity content, depending on values of the maximum and minimum indoor relative humidity, (for simplification) W_{max} and W_{min} respectively.

In order to get the humidity content which achieves the relative humidity needed, the following relationship must be realized:

$$W_{min} \leq W_{indoors} \leq W_{max} \quad (61)$$

This relation means that curve of $W_{indoors}$ (or W for simplification) must be under or equal to curve of W_{max} during the period of occupancy, and must be above or equal to curve of W_{min} . In order to detect when the relation (61) becomes unrealized, it is easier to check whether:

$$W_{max} - W_{indoors} \geq 0, W_{indoors} - W_{min} \geq 0 \quad (62)$$

Hence, if the relations (62) are unrealized, that means added/removed water rate must be modified.

6.4 Model of detecting condensation on the walls

Atmospheric water vapour condenses when it is in contact with a surface at or below the dew point. The dew point is the temperature at which the water vapour reaches saturation, or 100% relative humidity. Condensation becomes a problem when it occurs either:

- a) On interior surfaces of walls, ceilings, windows, etc.
- b) On the interior of building cavities such as wall cavities, in roof or attic spaces, etc.

Condensation may be controlled or avoided by controlling relative humidities, or controlling the temperature of interior surfaces.

The short and long term costs of damage caused by condensation, justify consideration of means of avoiding it. It may be controlled by a combination of ventilation, vapour barrier and insulation.

Under normal circumstances air is not saturated with water. When considering condensation control, it is necessary to calculate the temperature of the internal wall or ceiling surface when the outside temperature is at the lowest level anticipated, as follows [72]:

$$T_s = T_{indoor} - (Q / h_{inside}) \tag{63}$$

Where:

T_s [°C]: internal surface temperature.

Q [W/m²]: calculated heat flow per square metre per second.

h_{inside} [W/m².K]: convection heat transfer coefficient inside.

If the internal surface temperature calculated in this manner is less than the anticipated dew point temperature, there is a risk of condensation forming on the surface. This can promote mould growth and the accumulation of dust and stains, and lead to the eventual breakdown of paint and paper finishes.

- **Temperature external wall surface inside (T_s):**

Figure 57 shows heat transfer through an external wall.

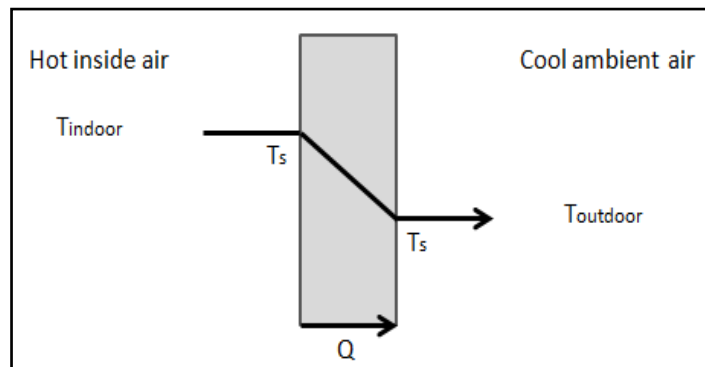

Figure 57: Heat exchange through the wall

Heat exchange through the wall can be expressed by the relation [72]:

$$Q = U.A.(T_{outdoor} - T_{indoor}) = A.h_{inside}.(T_s - T_{indoor}) \quad (64)$$

Where:

U [W/m².K]: the overall heat transfer coefficient.

A [m²]: area of external wall surface inside.

Then, temperature of external wall surface inside (T_s) can be calculated as follows:

$$T_s = \frac{Q}{A.h_{inside}} + T_{indoor} \quad (65)$$

- **Dew point of external wall surface inside (T_d):**

a) Water vapour saturation pressure can be calculated as follows ([73], [74]):

$$P_{ws} = A.10^{\left(\frac{m.T}{T+T_n}\right)} \quad (66)$$

Where:

P_{ws} [hPa]: Water vapour saturation pressure.

A, m, T_n : constants from Table 7 [74].

T [°C]: temperature.

Table 7: Constants for relation of water vapour saturation pressure

Temperature range(°C)	A	m	Tn	max error
over water:				
-20 ... 50	6.1162	7.5892	240.71	0.09%
50 ... 100	5.9987	7.3313	229.1	0.01%
100 ... 150	5.8493	7.2756	225	0.01%
150 ... 200	6.2301	7.3033	230	0.01%
200 ... 350	10.20614	7.364473	262.76	0.59%
0 ... 200	6.0964	7.33354	230.5	0.38%
Over ice:				
-70 ... 0	6.1134	9.7911	273.47	0.05%

According to the temperatures range in the Model: $A=6.1162, m=7.5892, T_n=240.71$

b) Water vapour pressure (P_w) can be calculated as follows [74]:

$$P_w = \frac{P_{ws} \cdot RH_{indoors}}{100} \quad (67)$$

Where:

P_w [hPa]: water vapour pressure.

$RH_{indoors}$ [%]: indoor relative humidity.

c) Dew point (T_d) can be calculated using the relation [74]:

$$T_d = \frac{T_n}{\frac{m}{\log\left(\frac{P_w}{A}\right)} - 1} \quad (68)$$

Then: if $T_s > T_d$, there is no condensation.

T_s and T_d can be simulated by using MATLAB/SIMULINK, as shown in Figure 58.

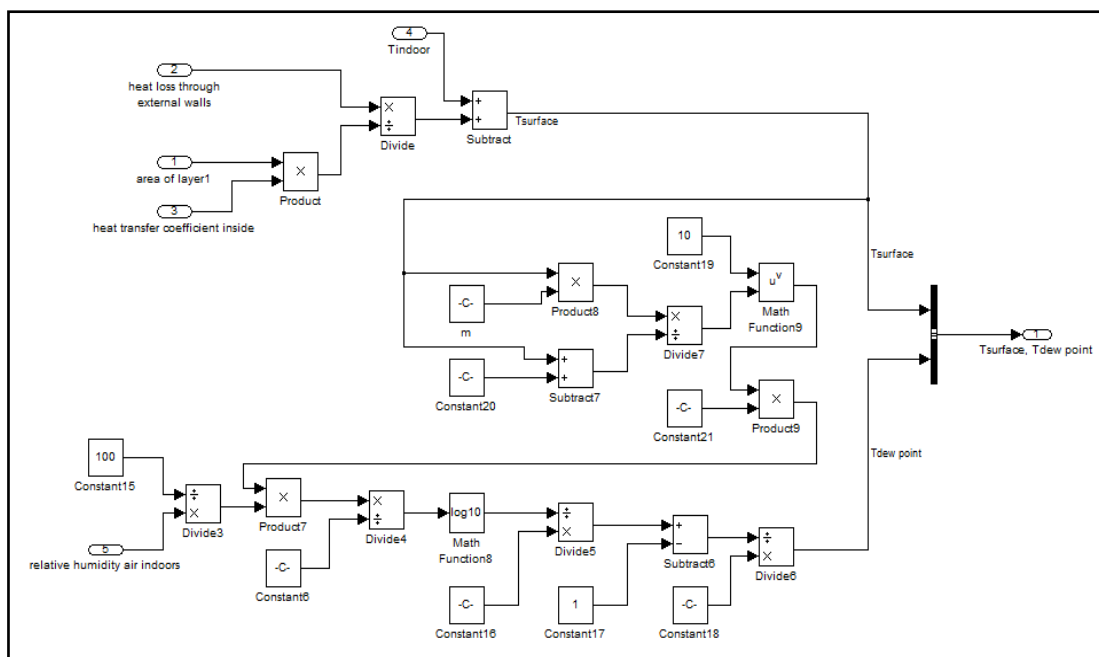

Figure 58: Model detecting condensation on the inside walls

7 VALIDATION AND RESULTS

7.1 Enterprise Buildings Integrator (EBI)

The results have been compared with the results recorded by a monitoring system installed in the building “Honeywell Enterprise Buildings Integrator (EBI)”. Its interface on PC is shown in Figure 59. This system is a suite of applications that provide a complete solution for the information access and control needs of one or more buildings such as security, fire-life-safety, ventilation, lighting, health and comfort.

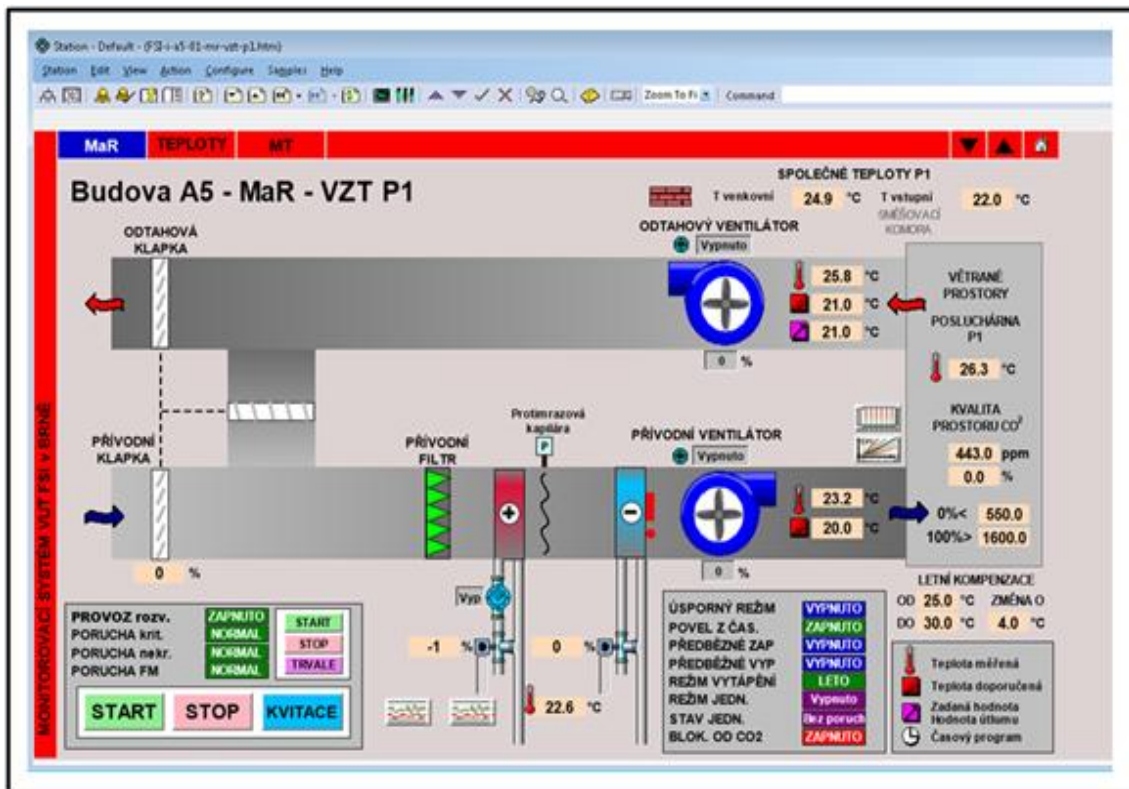

Figure 59: Interface panel of Honeywell Enterprise Buildings Integrator (EBI)

EBI is a system that allows monitoring and controlling, through a simple web-style window, subsystems including HVAC, Lighting Energy, Environment control, Smoke and Fire Alarms, Security, Access Control, and relating personal, finance, statistical, or user databases. A typical EBI system hardware consists of [75]:

- A PC configured as an EBI Server.
- A number of PCs configured as Workstations.
- A wide range of controllers.
- Communication hardware.
- Printers for reporting tasks.

EBI software communicates with the controllers, providing a complete system for control and monitoring. These controllers can be HVAC, programmable logic controllers (PLC), access controllers, safety controllers, fire alarm panels, CCTV switchers. Its main function is collecting data and transmitting them to the server.

There are several modes of communicating with server. They depend on the controller type. Some of them are Open Networks, Terminal server, and proprietary Networks. Operators can interact with EBI Server using an Operator Station.

Station software normally runs on one or more PCs, which are connected to the server through a network connection. Station can also run on the same PC where EBI Server is running. One or more printers can be configured in the system in order to print alarms, events, reports and displays. Hence, the Honeywell EBI suite of applications provides intelligent control of core facility functions.

7.2 Results

Measurements and validation processes have been carried out in accordance with a specified methodology, as follows:

Needed weather data which have been obtained from meteorological station (TUBO), have been exported to the model in order to validate the results under different climatic conditions with different occupancies, as follows:

Two days with low temperatures

Two days with high temperatures

Two days with mild temperatures

The occupancy within the classroom has been monitored during a specified period. Where, the total capacity is 190 seats.

The values of supply air flow, air-conditioner temperature and the proportion of fresh air flow, respectively, have been obtained from the monitoring system "EBI".

These values have been inserted to the model, with the corresponding size of occupancy. Then, simulation process has been run, and the results have been compared with the results of the monitoring system "EBI".

These results are:

- Indoor temperature.
- Indoor temperature after the minimum amount of heat calculated according to the method described in (section 4.4) was added/removed to/from the indoor space.
- Relative humidity and humidity content. Then through the values of the corresponding temperatures can check the validity by comparing with Psychrometric chart.
- Relative humidity and humidity content (humidity ratio or specific humidity) after using the way of calculation the rate of added/removed of water needed to keep indoor relative humidity within the allowable values which meet the requirements of the occupants, described in (section 6.3)
- Verification of the validity of the approach described in (section 6.3) through the comparison of humidity content after conditioning with the maximum and minimum humidity content.
- Compare values of the temperature on the internal surface of external walls with temperatures dew point on those surfaces to verify the absence of condensation.
- Indoor concentration of carbon dioxide to check air quality achieved by the strategies which have been modelled, are: traditional strategy and demand controlled ventilation (DCV) strategy.

- Air flow rate for the two strategies.
- The total amount of fresh air supplied into the classroom for the two strategies.
- Amount of energy saving for heating/cooling when using demand controlled ventilation (DCV) strategy.

First, results have been displayed for a whole day without conditioned indoor space, and without occupancy.

To run simulation, the initial temperatures of layers must be calculated, as shown in Figure 60.

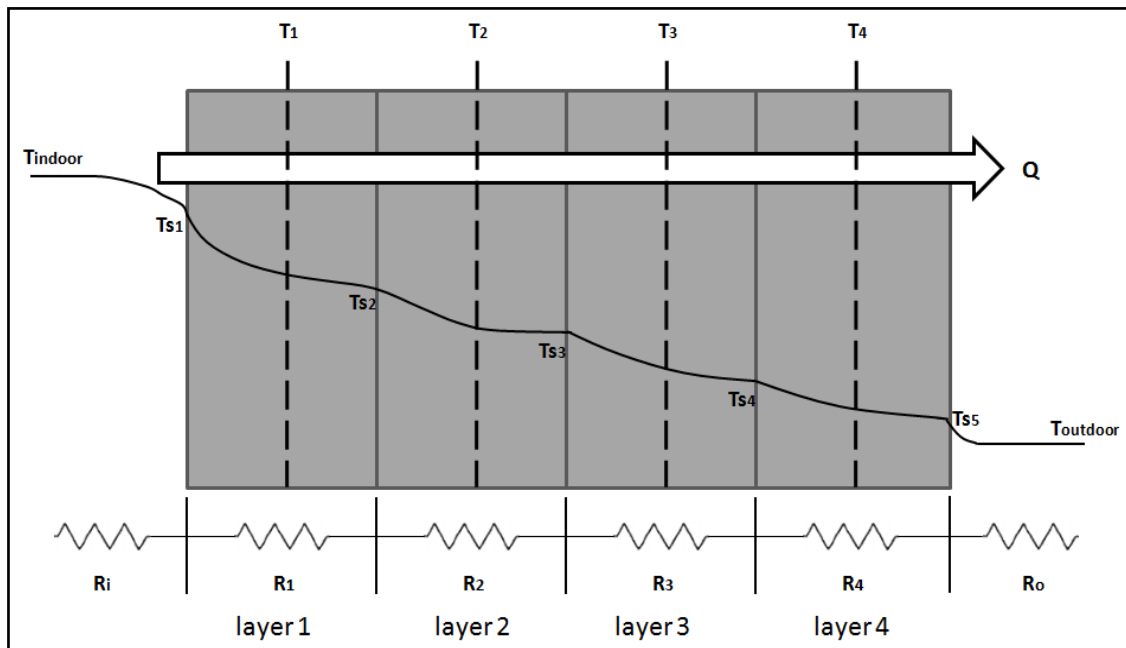

Figure 60: Wall layers and their thermal network

Where, each element of the total thermal resistance through the wall can be calculated as follows:

$$R_i = \frac{1}{h_{inside} \cdot A_1}, R_1 = \frac{L_1}{k_1 \cdot A_1}, R_2 = \frac{L_2}{k_2 \cdot A_2}, R_3 = \frac{L_3}{k_3 \cdot A_3}, R_4 = \frac{L_4}{k_4 \cdot A_4}, R_o = \frac{1}{h_{outside} \cdot A_{outside}} \quad (69)$$

By knowing (T_{indoor}) in the time 00:00 from EBI system, and ($T_{outdoor}$) from TUBO data, initial temperature of all layers can be calculated in the steady-state as follows:

$$\bullet \quad \frac{T_{indoor} - T_1}{R_i + \frac{R_1}{2}} = \frac{T_{indoor} - T_{outdoor}}{R_i + R_1 + R_2 + R_3 + R_4 + R_o} \quad (70)$$

$$T_1 = T_{indoor} - \frac{T_{indoor} - T_{outdoor}}{R_i + R_1 + R_2 + R_3 + R_4 + R_o} \left(R_i + \frac{R_1}{2} \right) \quad (71)$$

$$\bullet \frac{T_{indoor} - T_2}{R_i + R_1 + \frac{R_2}{2}} = \frac{T_{indoor} - T_{outdoor}}{R_i + R_1 + R_2 + R_3 + R_4 + R_o} \quad (72)$$

$$T_2 = T_{indoor} - \frac{T_{indoor} - T_{outdoor}}{R_i + R_1 + R_2 + R_3 + R_4 + R_o} (R_i + R_1 + \frac{R_2}{2}) \quad (73)$$

$$\bullet \frac{T_{indoor} - T_3}{R_i + R_1 + R_2 + \frac{R_3}{2}} = \frac{T_{indoor} - T_{outdoor}}{R_i + R_1 + R_2 + R_3 + R_4 + R_o} \quad (74)$$

$$T_3 = T_{indoor} - \frac{T_{indoor} - T_{outdoor}}{R_i + R_1 + R_2 + R_3 + R_4 + R_o} (R_i + R_1 + R_2 + \frac{R_3}{2}) \quad (75)$$

$$\bullet \frac{T_4 - T_{outdoor}}{R_o + \frac{R_4}{2}} = \frac{T_{indoor} - T_{outdoor}}{R_i + R_1 + R_2 + R_3 + R_4 + R_o} \quad (76)$$

$$T_4 = T_{outdoor} + \frac{T_{indoor} - T_{outdoor}}{R_i + R_1 + R_2 + R_3 + R_4 + R_o} (R_o + \frac{R_4}{2}) \quad (77)$$

Sub-model for calculation of initial temperatures is shown in Figure 61.

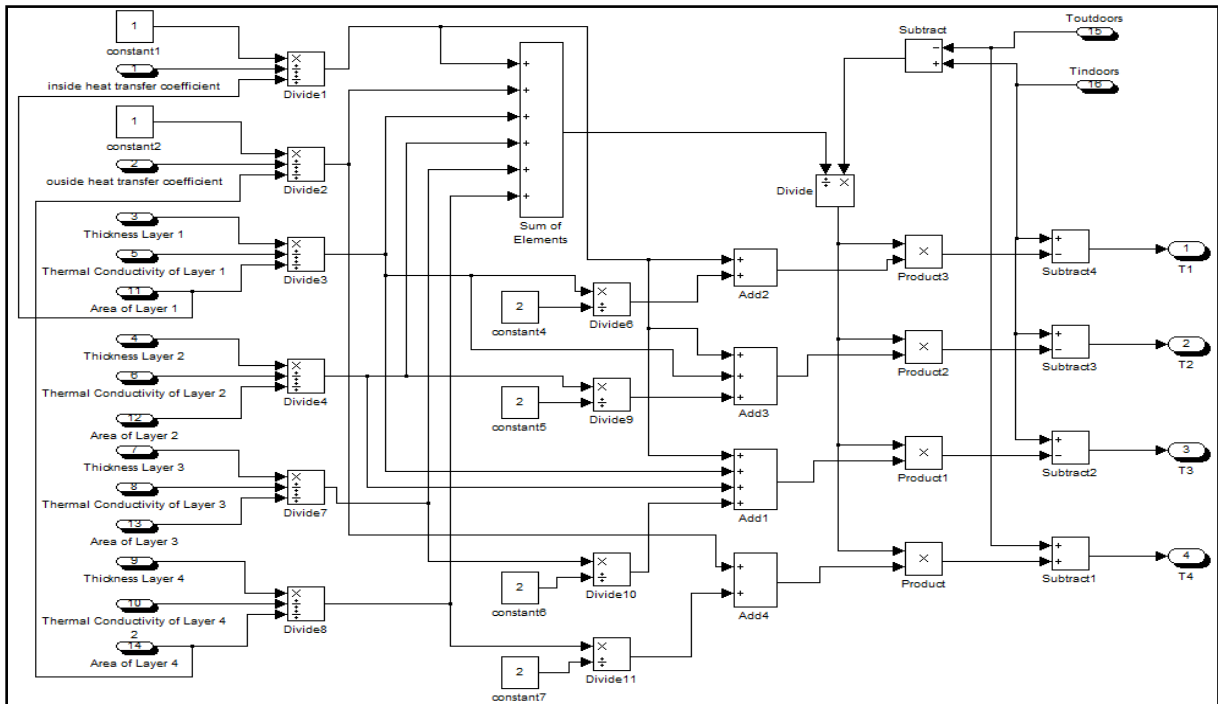

Figure 61: sub-model for initial temperatures of layers

The results are as follows:

August 8/8/2013

Period	16:00:00-18:40:00
mass flow of supply air	0kg/s
mass flow of fresh air (base rate)	0kg/s
maximum conditioner temperature	-
number of occupants	0

Results of the whole day

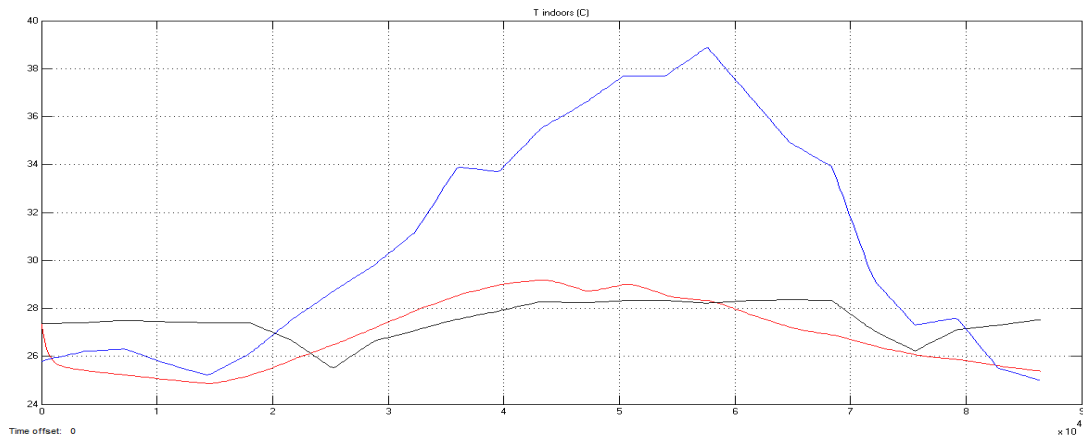

Red: simulation result
 Black: values monitored by Honeywell system
 Blue: outdoor temperature obtained by TUBO station

Results of the period specified above in the table (It is the method which will be used in all results)

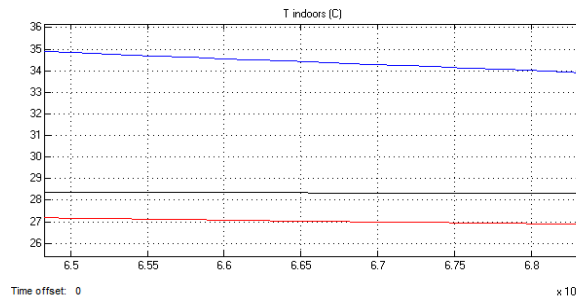

Red: simulation result
 Black: values monitored by Honeywell system
 Blue: outdoor temperature obtained by TUBO station

Modelling temperature

Relative humidity

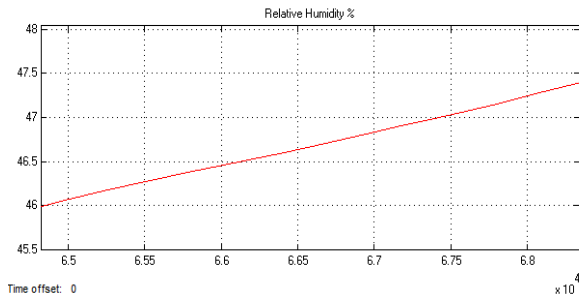

Humidity ratio

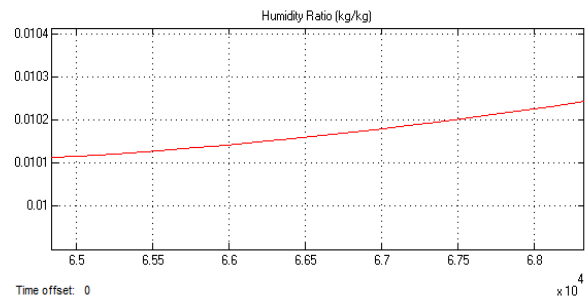

Modelling humidity

NNW wall

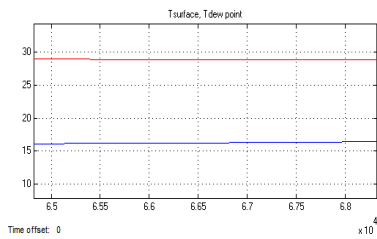

Red: Tsurface
Blue: T dew point

SSE wall

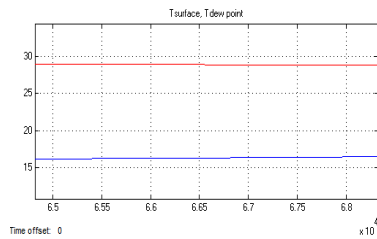

Red: Tsurface
Blue: T dew point

ENE wall

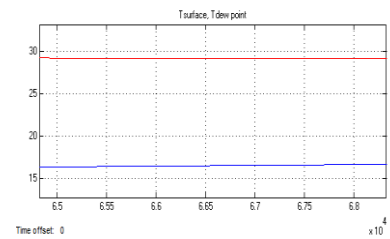

Red: Tsurface
Blue: T dew point

Comparison of T_{surface} and T_{dew point} for the external walls (condensation risk)

CO₂ concentration [ppm]

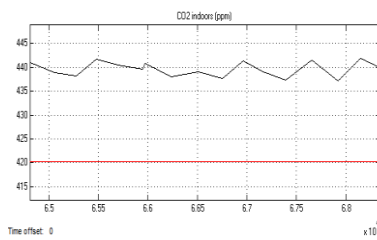

Red: simulation result
Black: values monitored by Honeywell system

Air flow rate [m³/s]

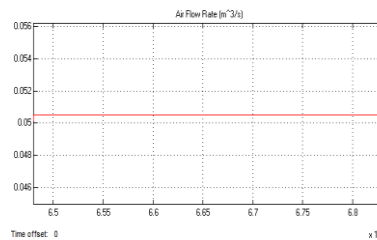

Red: simulation results

The total amount of fresh air supplied into the classroom [m³]

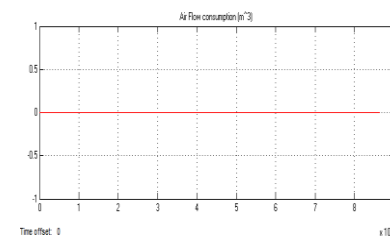

Red: simulation results

Modelling ventilation

Mild day, with occupancy 37%

October 22/10/2012

Period	10:50:00-12:13:00
mass flow of supply air	3 kg/s
mass flow of fresh air	1.5 kg/s
maximum heater temperature	21 °C
occupancy	70

Simulation result for the actual strategy used in building

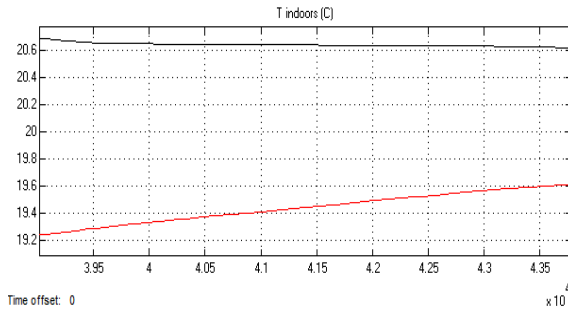

Modelling $T_{\text{conditioner}}$: $T_{\text{conditioner}} = 20.5 \text{ °C}$

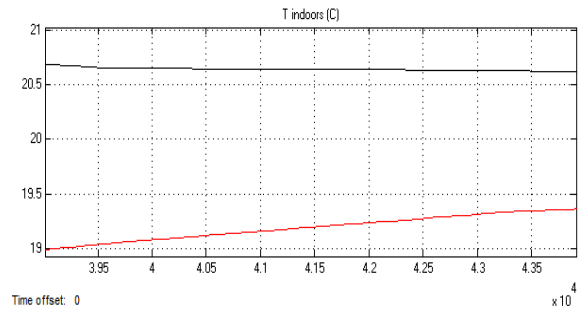

Red: simulation result for the actual strategy used in building
Black: values monitored by Honeywell system

Modelling temperature

Relative humidity before conditioning

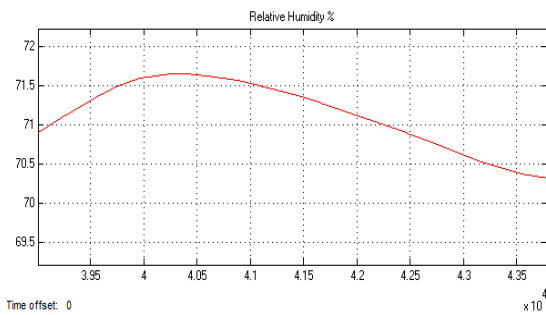

Humidity ratio before conditioning

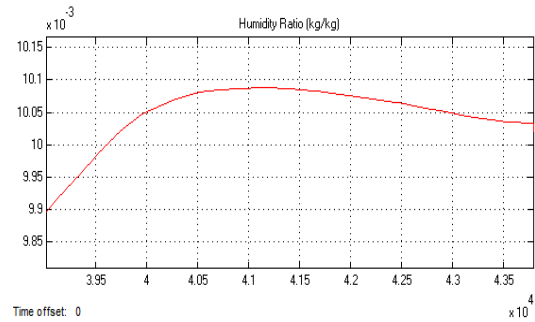

After conditioning: 0.0053 kg/s removed water

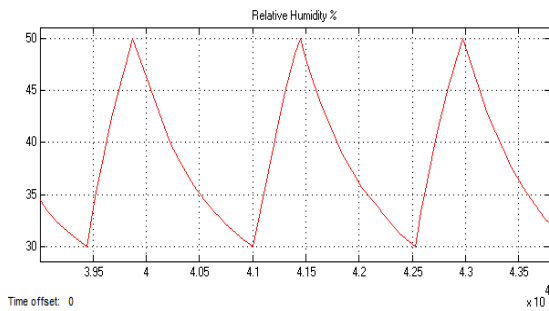

After conditioning: 0.0053 kg/s removed water

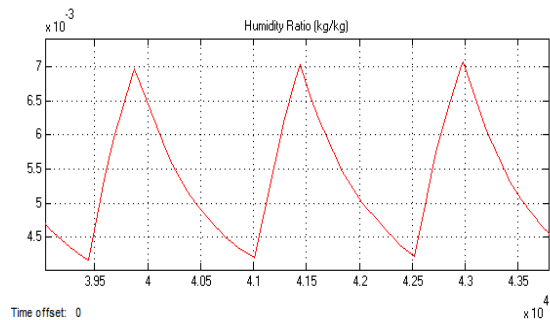

Modelling humidity

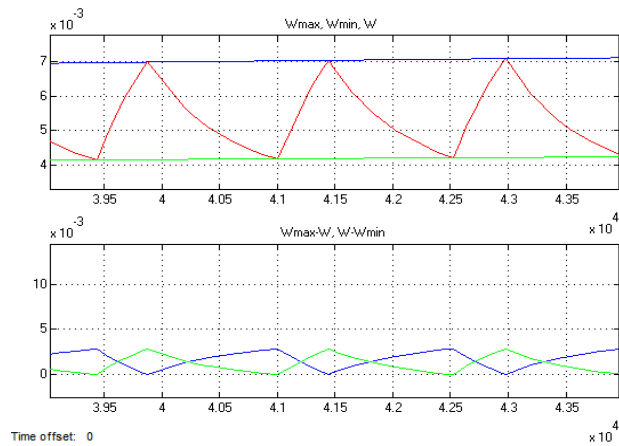

Blue top: W_{max}
 Green top: W_{min}
 Red: W
 Blue lower: $W_{max}-W$
 Green lower: $W-W_{min}$

Verification of humidity control

NNW wall

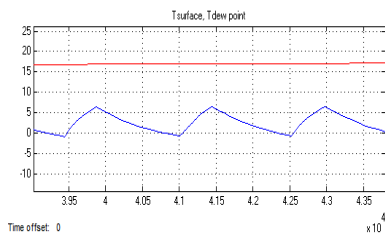

Red: $T_{surface}$
 Blue: $T_{dew\ point}$

SSE wall

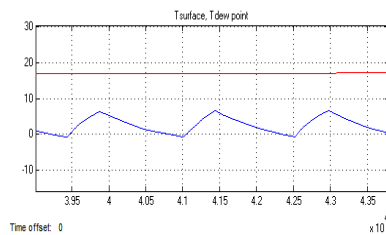

Red: $T_{surface}$
 Blue: $T_{dew\ point}$

ENE wall

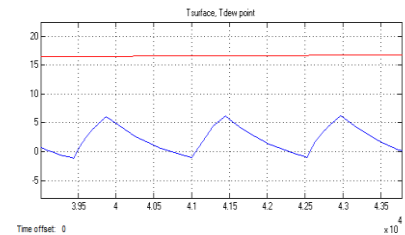

Red: $T_{surface}$
 Blue: $T_{dew\ point}$

Comparison of $T_{surface}$ and $T_{dew\ point}$ for the external walls (condensation risk)

CO₂ concentration [ppm]

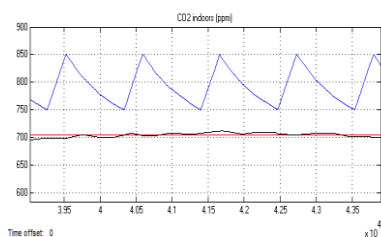

Blue: simulation results of DCV for $CO_2\ setpoint\ 800 \pm 50\ ppm$
 Red: simulation results for the actual strategy used in building
 Black: Measured values monitored by Honeywell system

Air flow rate [m^3/s]

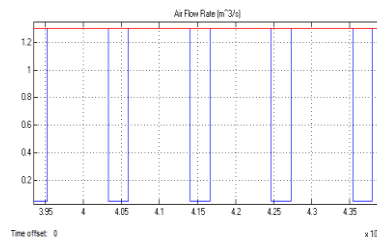

Blue: simulation results of DCV for $CO_2\ setpoint\ 800 \pm 50\ ppm$
 Red: simulation results for the actual strategy used in building

The total amount of fresh air supplied into the classroom [m^3]

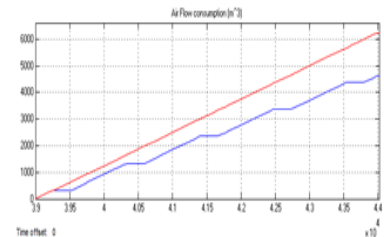

Blue: simulation results of DCV for $CO_2\ setpoint\ 800 \pm 50\ ppm$
 Red: simulation results for the actual strategy used in building

Modelling ventilation

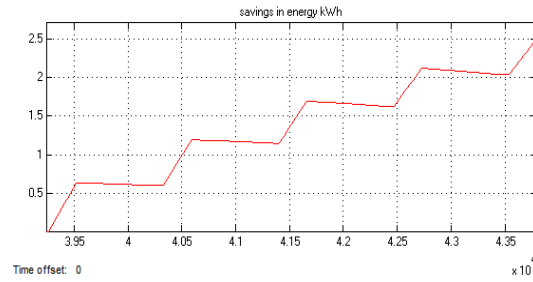

Savings in energy for heating/cooling by using DCV

Although the outdoor temperature is mild, but there is a saving in energy, because the size of occupancy is significant. Therefore, there will be a clear impact due to controlling the flow of air based on demand (Demand controlled ventilation), so that the air quality remains within the allowable values.

Cold day, with occupancy 3%

December 7/12/2012

Period	10:33:00-11:33:00
mass flow of supply air	0.75 kg/s
mass flow of fresh air	0.225 kg/s
maximum heater temperature	45 °C
occupancy	6

Simulation result for the actual strategy used in building

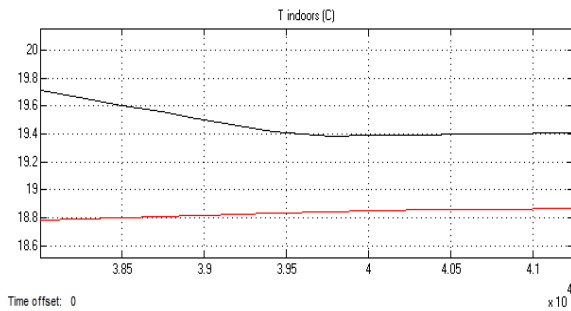

Modelling $T_{\text{conditioner}}$: $T_{\text{conditioner}} = 45\text{ °C}$

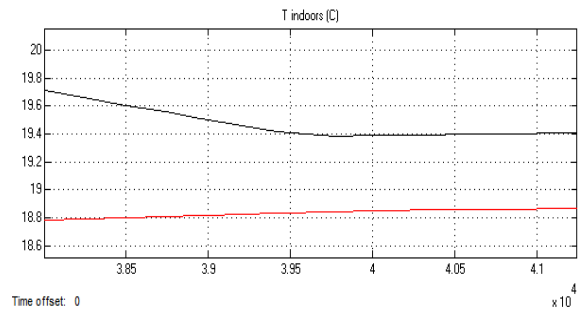

Red: simulation result for the actual strategy used in building
 Black: values monitored by Honeywell system

Modelling temperature

Relative humidity before conditioning

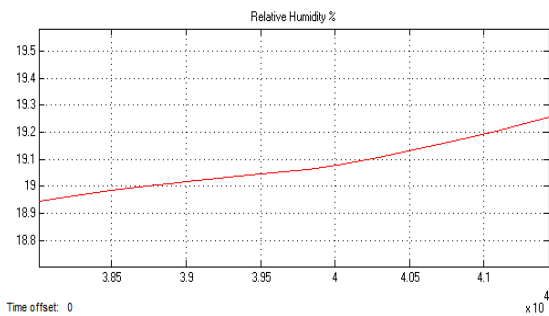

Humidity ratio before conditioning

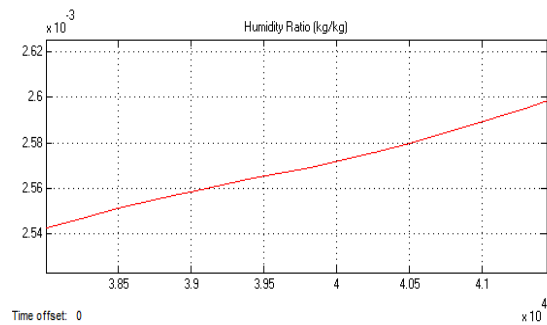

After conditioning: 0.00088 kg/s added water

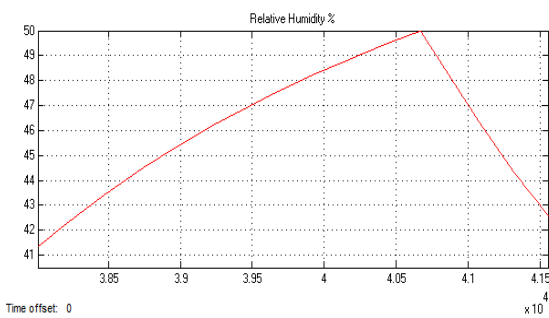

After conditioning: 0.00088 kg/s added water

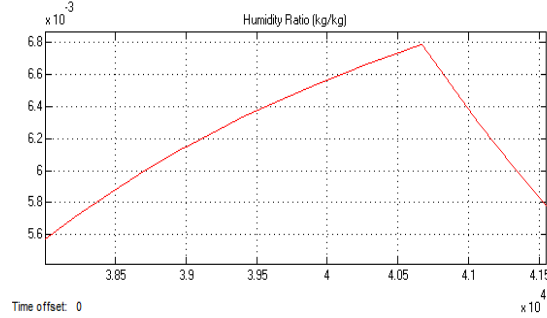

Modelling humidity

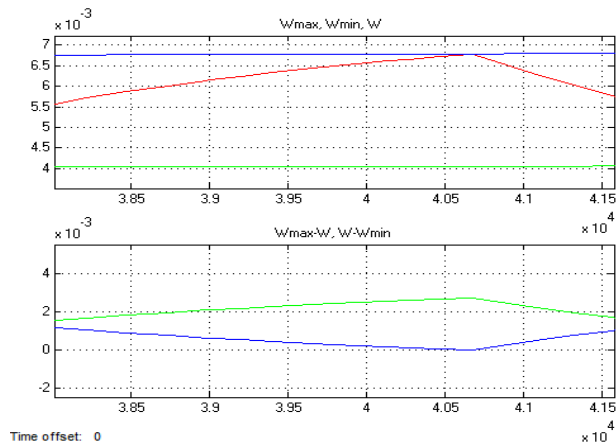

Blue top: W_{max}
 Green top: W_{min}
 Red: W
 Blue lower: $W_{max}-W$
 Green lower: $W-W_{min}$

Verification of humidity control

NNW wall

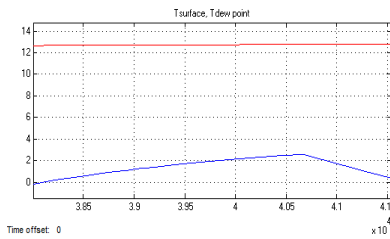

Red: $T_{surface}$
 Blue: $T_{dew\ point}$

SSE wall

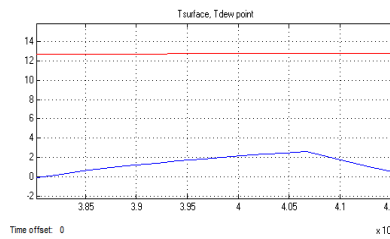

Red: $T_{surface}$
 Blue: $T_{dew\ point}$

ENE wall

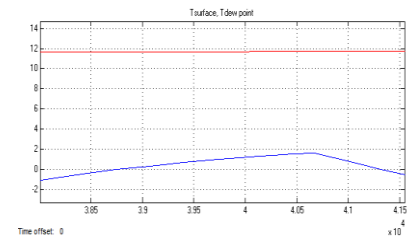

Red: $T_{surface}$
 Blue: $T_{dew\ point}$

Comparison of $T_{surface}$ and $T_{dew\ point}$ for the external walls (condensation risk)

CO₂ concentration [ppm]

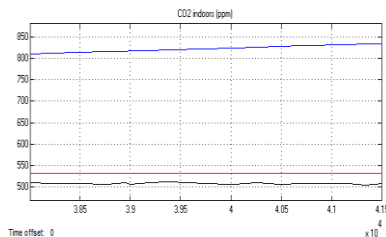

Blue: simulation results of DCV for CO₂ setpoint 800 ± 50 ppm
 Red: simulation results for the actual strategy used in building
 Black: Measured values monitored by Honeywell system

Air flow rate [m³/s]

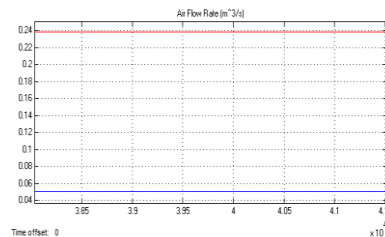

Blue: simulation results of DCV for CO₂ setpoint 800 ± 50 ppm
 Red: simulation results for the actual strategy used in building

The total amount of fresh air supplied into the classroom [m³]

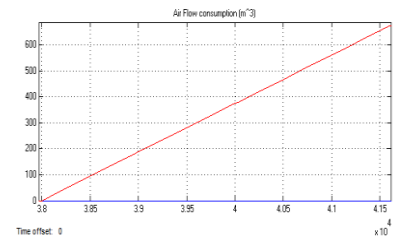

Blue: simulation results of DCV for CO₂ setpoint 800 ± 50 ppm
 Red: simulation results for the actual strategy used in building

Modelling ventilation

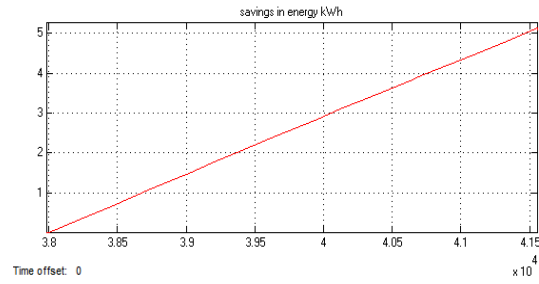

Savings in energy for heating/cooling by using DCV

The amount of savings in energy is significant. These savings have been achieved in spite of low occupancy. The reason basically is that any savings in the energy required to heat the cold air is significant.

Cold day and no occupancy, where, fresh air is just the base rate (no need to use DCV)

February 21/2/2013

Period	7:00-8:00
mass flow of supply air	0.75 kg/s
mass flow of fresh air (base rate)	0.225 kg/s
maximum heater temperature	46 °C
occupancy	0

Simulation result for the actual strategy used in building

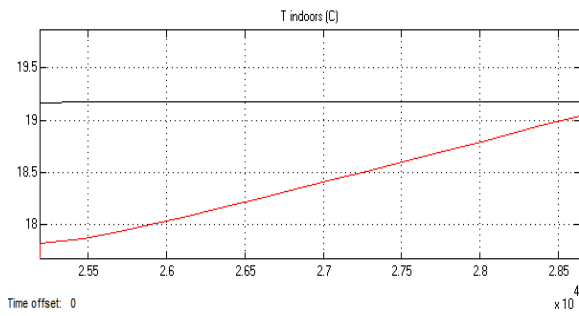

Modelling $T_{\text{conditioner}}$: $T_{\text{conditioner}} = 46 \text{ °C}$

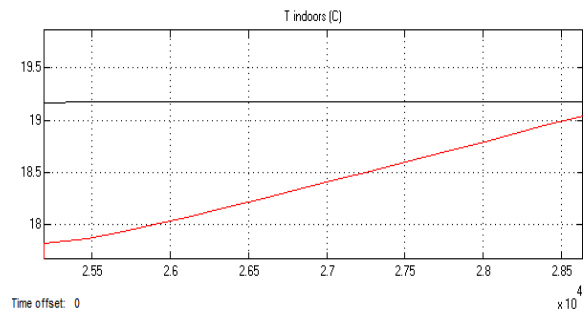

Red: simulation result for the actual strategy used in building
Black: values monitored by Honeywell system

Modelling temperature

Relative humidity before conditioning

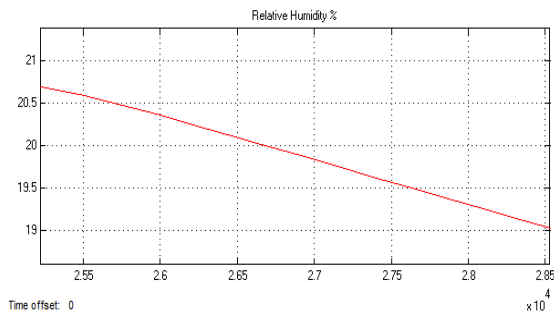

After conditioning: 0.00086 kg/s added water

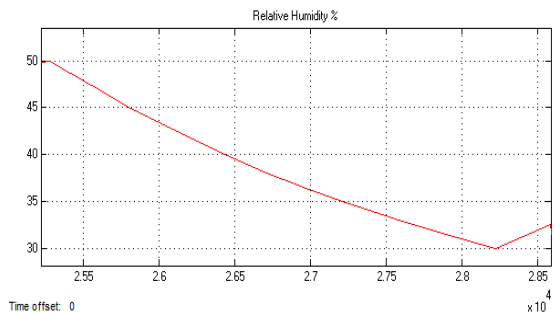

Humidity ratio before conditioning

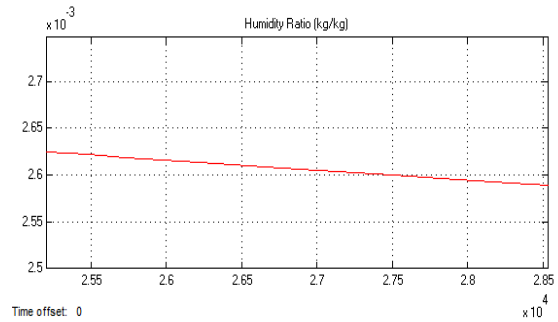

After conditioning: 0.00086 kg/s added water

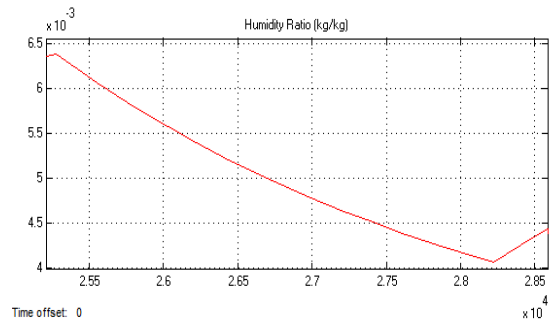

Modelling humidity

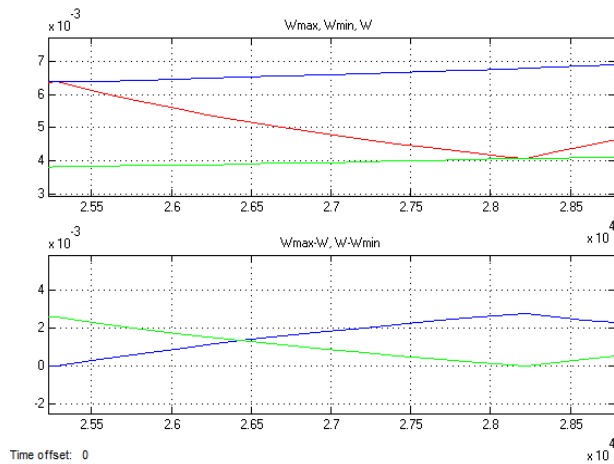

Blue top: W_{max}
 Green top: W_{min}
 Red: W
 Blue lower: $W_{max}-W$
 Green lower: $W-W_{min}$

Verification of humidity control

NNW wall

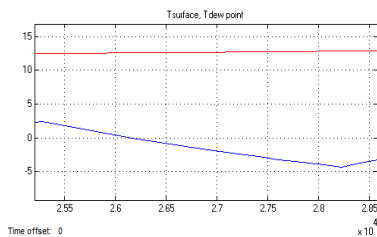

Red: $T_{surface}$
 Blue: $T_{dew\ point}$

SSE wall

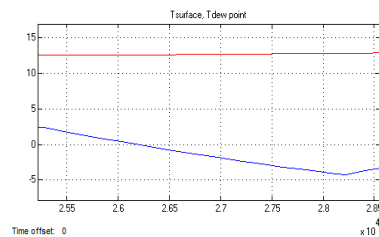

Red: $T_{surface}$
 Blue: $T_{dew\ point}$

ENE wall

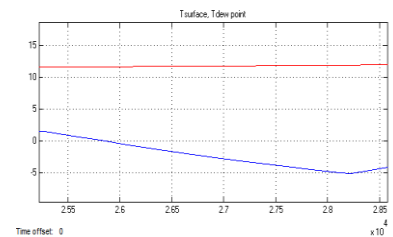

Red: $T_{surface}$
 Blue: $T_{dew\ point}$

Comparing of $T_{surface}$ and $T_{dew\ point}$ for the external walls (condensation risk)

CO₂ concentration [ppm]

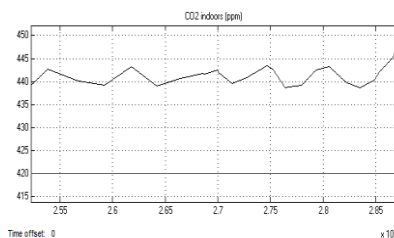

Red: simulation result for the actual strategy used in building
 Black: values monitored by Honeywell system

Air flow rate [m³/s]

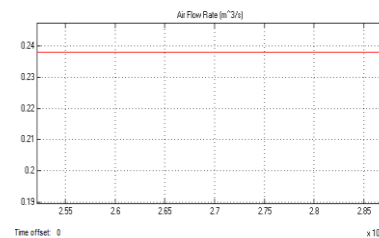

Red: simulation results for the actual strategy used in building

The total amount of fresh air supplied into the classroom [m³]

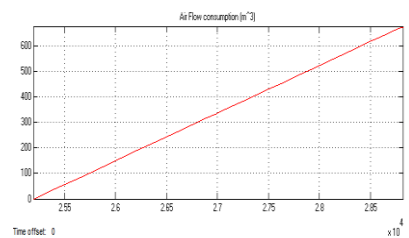

Red: simulation results for the actual strategy used in building

Modelling ventilation

Mild day, with occupancy 2%

May 7/5/2013

Period	14:51:00-16:13:00
mass flow of supply air	0.75kg/s
mass flow of fresh air	0.225 kg/s
maximum heater temperature	21 C (no heating nor cooling)
occupancy	4

Simulation result for the actual strategy used in building

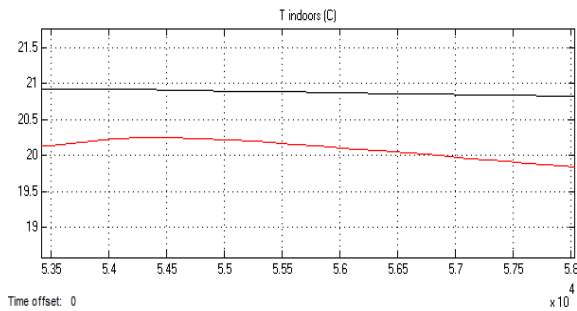

Modelling $T_{conditioner}$: $T_{conditioner} = 21^{\circ}C$

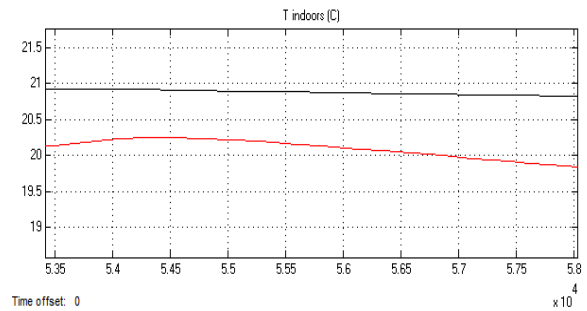

Red: simulation result for the actual strategy used in building
Black: values monitored by Honeywell system

Modelling temperature

Relative humidity before conditioning

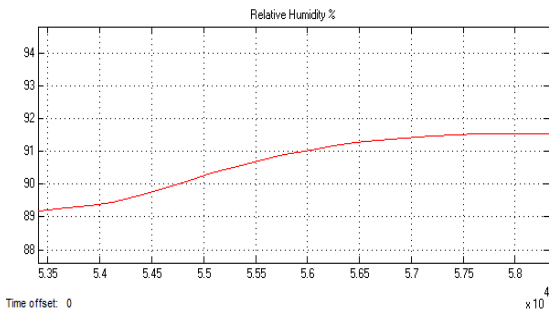

Humidity ratio before conditioning

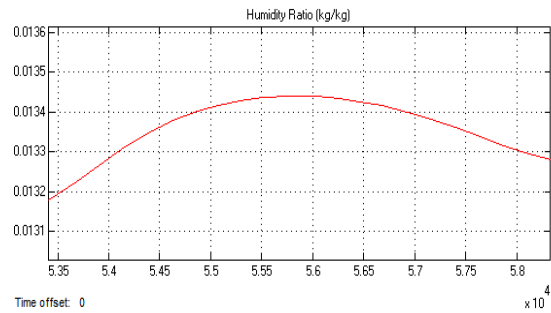

After conditioning: 0.0033 kg/s removed water

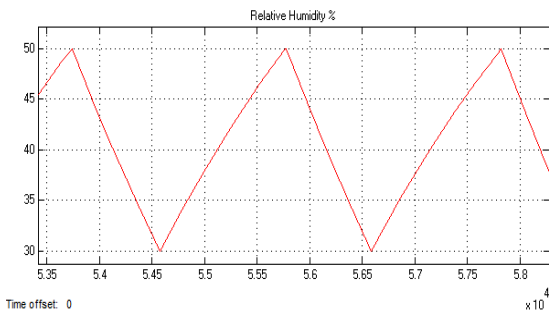

After conditioning: 0.0033 kg/s removed water

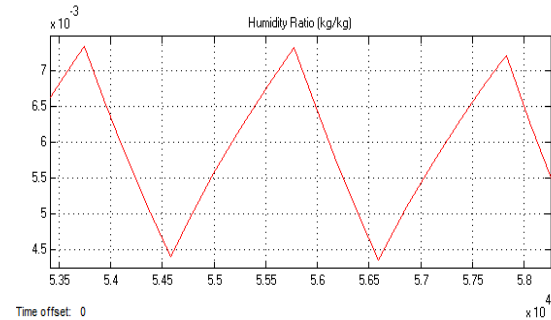

Modelling humidity

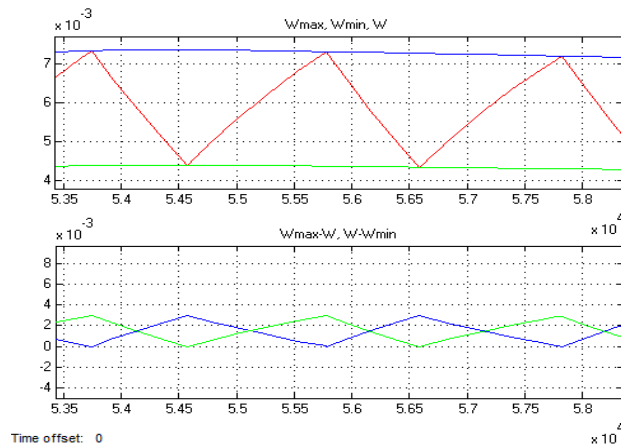

Blue top: W_{max}
 Green top: W_{min}
 Red: W
 Blue lower: $W_{max}-W$
 Green lower: $W-W_{min}$

Verification of humidity control

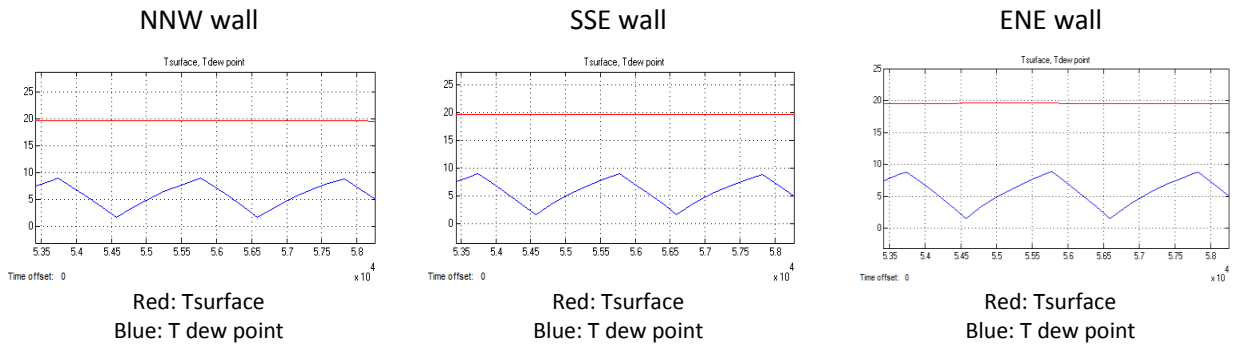

Comparing of between $T_{surface}$ and $T_{dew\ point}$ for the external walls (condensation risk)

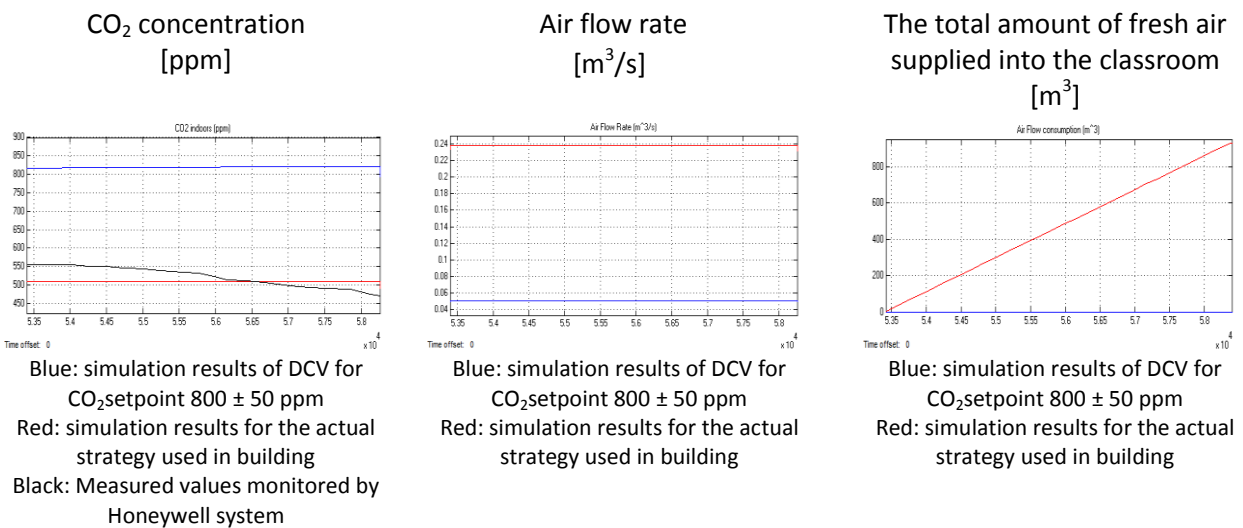

Modelling ventilation

As long as there is no air conditioning, the use of DCV strategy has no effect on energy consumption, although there are savings in air consumption.

Hot day, with occupancy 18%

June 20/6/2013

Period	9:06:00- 9:50:00
mass flow of supply air	3 kg/s
mass flow of fresh air	1.26 kg/s
conditioner temperature	19 °C
number of occupants	34

Simulation result for the actual strategy used in building

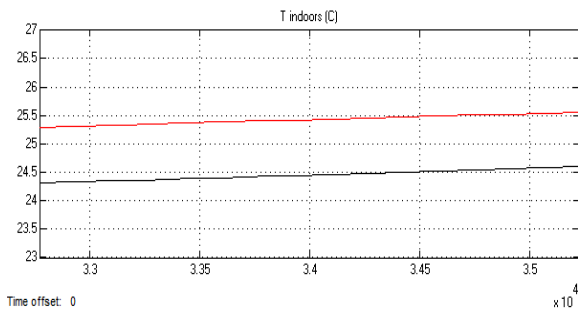

Modelling T_{conditioner}: T_{conditioner} = 17.5 °C

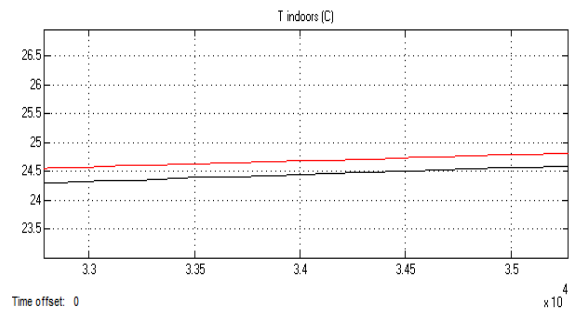

Red: simulation result for the actual strategy used in building
 Black: values monitored by Honeywell system

Modelling temperature

Relative humidity before conditioning

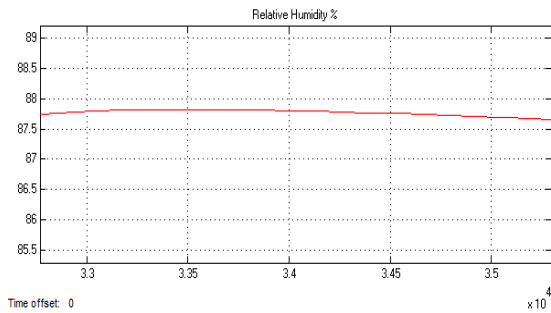

Humidity ratio before conditioning

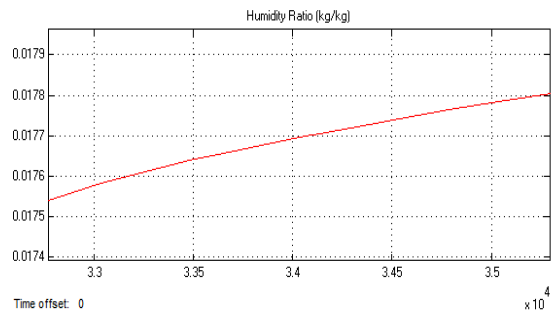

After conditioning: 0.0134 kg/s removed water

After conditioning: 0.0134 kg/s removed water

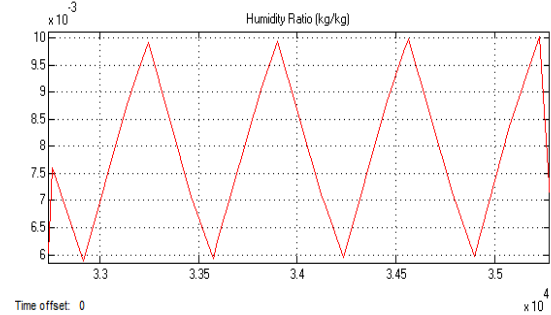
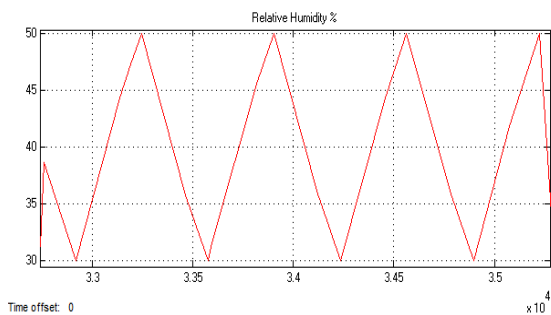

Modelling humidity

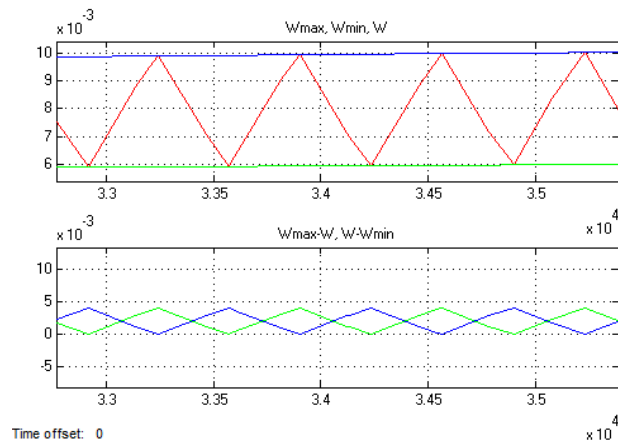

Blue top: W_{max}
 Green top: W_{min}
 Red: W
 Blue lower: $W_{max}-W$
 Green lower: $W-W_{min}$

Verification of humidity control

NNW wall

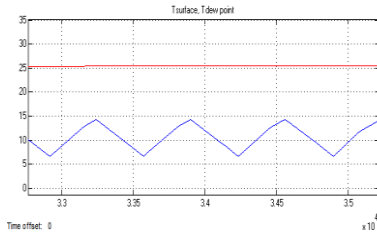

Red: $T_{surface}$
 Blue: $T_{dew\ point}$

SSE wall

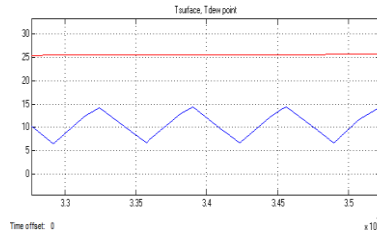

Red: $T_{surface}$
 Blue: $T_{dew\ point}$

ENE wall

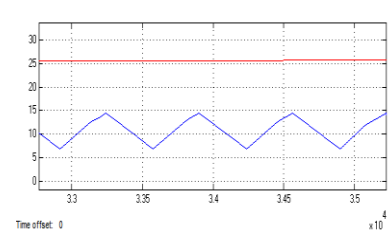

Red: $T_{surface}$
 Blue: $T_{dew\ point}$

Comparing of between $T_{surface}$ and $T_{dew\ point}$ for the external walls (condensation risk)

CO₂ concentration [ppm]

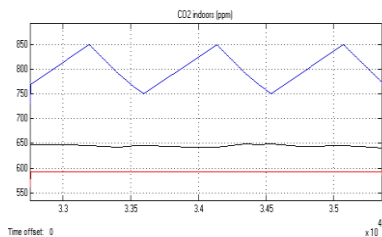

Blue: simulation results of DCV for $CO_2\ setpoint\ 800 \pm 50\ ppm$
 Red: simulation results for the actual strategy used in building
 Black: Measured values monitored by Honeywell system

Air flow rate [m^3/s]

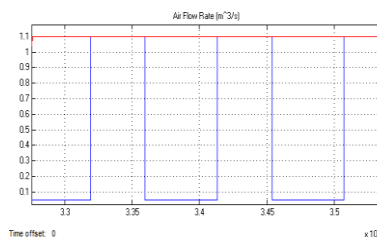

Blue: simulation results of DCV for $CO_2\ setpoint\ 800 \pm 50\ ppm$
 Red: simulation results for the actual strategy used in building

The total amount of fresh air supplied into the classroom [m^3]

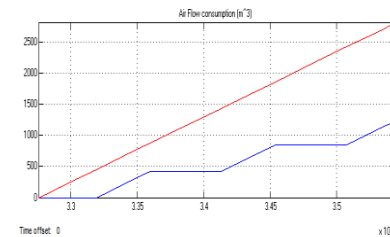

Blue: simulation results of DCV for $CO_2\ setpoint\ 800 \pm 50\ ppm$
 Red: simulation results for the actual strategy used in building

Modelling ventilation

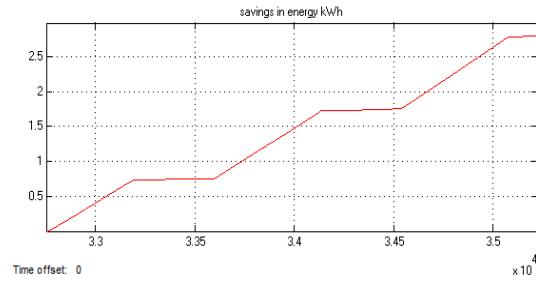

Savings in energy for heating/cooling by using DCV

The savings in fresh air supplied into the classroom and the savings in energy are significant, because conditioning of hot air requires more energy. Hence, DCV strategy has a significant impact on energy consumption for cooling.

Hot day and no occupancy, where, fresh air is just the base rate (no need to use DCV)

July 19/7/2013

Period	12:47:00 - 14:59:00
mass flow of supply air	3 kg/s
mass flow of fresh air (base rate)	1kg/s
conditioner temperature	19 °C
number of occupants	0

Simulation result for the actual strategy used in building

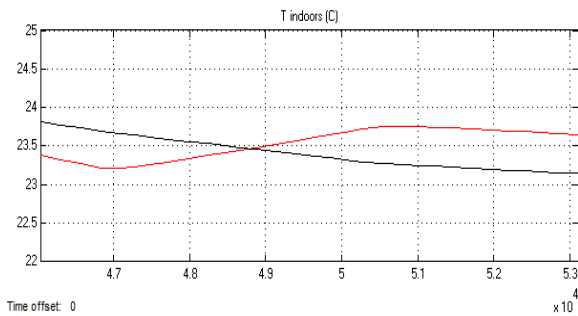

Modelling $T_{\text{conditioner}}$: $T_{\text{conditioner}} = 19^{\circ}\text{C}$

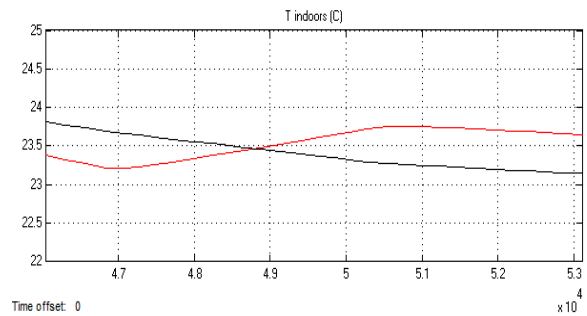

Red: simulation result for the actual strategy used in building
 Black: values monitored by Honeywell system

Modelling temperature

Relative humidity before conditioning

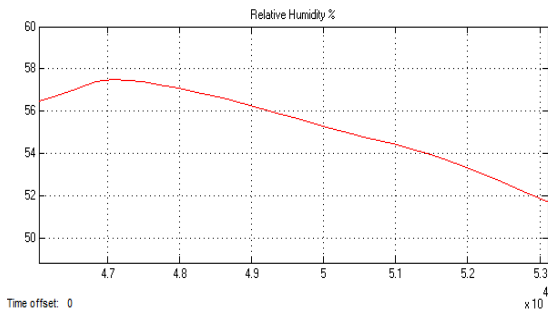

Humidity ratio before conditioning

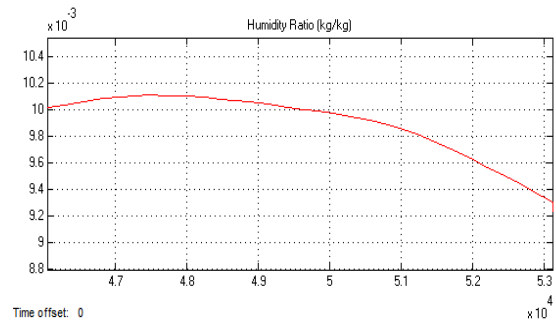

After conditioning: 0.001 kg/s removed water

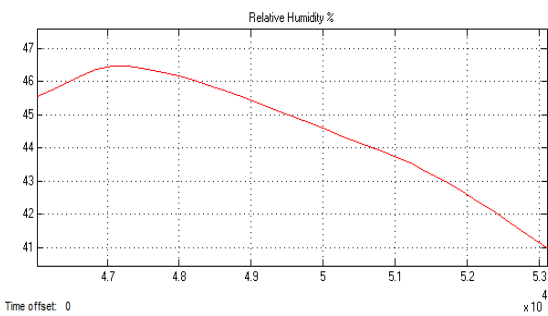

After conditioning: 0.001 kg/s removed water

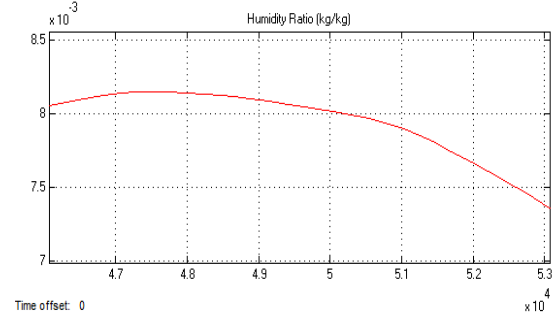

Modelling humidity

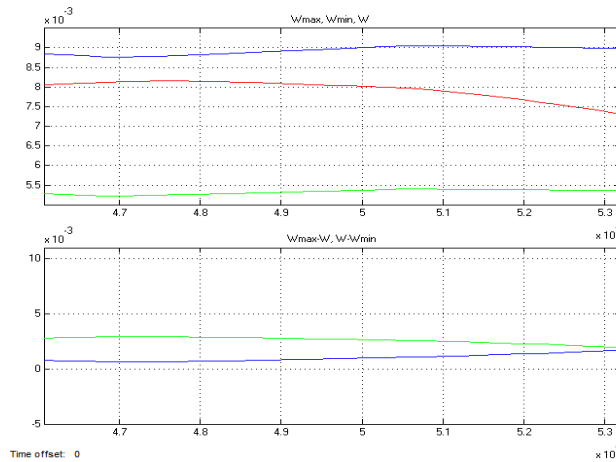

Blue top: W_{max}
 Green top: W_{min}
 Red: W
 Blue lower: $W_{max}-W$
 Green lower: $W-W_{min}$

Verification of humidity control

NNW wall

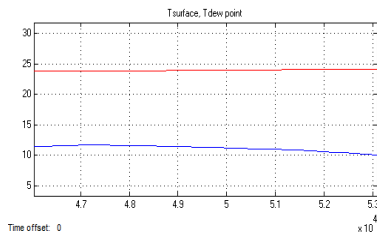

Red: Tsurface
 Blue: T dew point

SSE wall

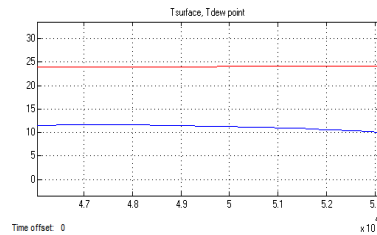

Red: Tsurface
 Blue: T dew point

ENE wall

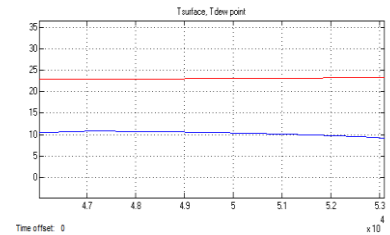

Red: Tsurface
 Blue: T dew point

Comparing of between $T_{surface}$ and $T_{dew point}$ for the external walls (condensation risk)

CO₂ concentration [ppm]

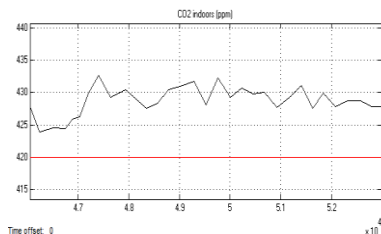

Red: simulation result for the actual strategy used in building
 Black: values monitored by Honeywell system

Air flow rate [m³/s]

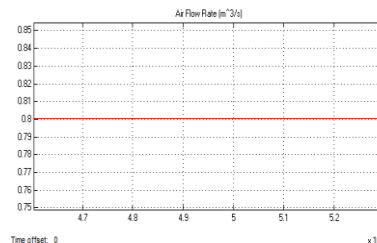

Red: simulation results for the actual strategy used in building

The total amount of fresh air supplied into the classroom [m³]

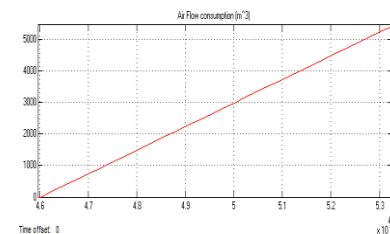

Red: simulation results for the actual strategy used in building

Modelling ventilation

The results have shown that if there is no air conditioning and without occupancy as was on 8/8/2013, the energy balance used for modelling indoor temperature has given results very close to the monitored temperature measured by EBI system in spite of the large amount of solar radiation incident on the walls. As well as the mass balance used for modelling indoor humidity and indoor concentration of carbon dioxide, CO₂, also has given results very close to the monitored values. This is what has given an indication of the possibility of continuing to add modelling air conditioning processes depending on the designed model.

For mild days, by using DCV strategy, there is a saving in energy when the size of occupancy is significant, as was on 22/10/2012. But if the outdoor temperature (taking into account the effect of solar radiation) is very close to the indoor temperature, the saving will be very small even for significant occupancy, as was on 23/4/2013 (in appendices).

In case there is a very small size of occupancy and there is no air conditioning, as was on 7/5/2013, the use of DCV strategy has no impact on energy consumption.

By the same way, if there is occupancy, but there is no air conditioning, as was on 27/9/2012 (in appendices), the use of DCV strategy has no impact on energy consumption.

If there is no occupancy nor air-conditioning, as was on 8/3/2013 (in appendices), basic parameters of indoor environment (temperature, relative humidity, CO₂ concentration) are also close to the monitored values.

For cold days, the amount of savings in energy is significant even for low occupancy, as was on 7/12/2012, because the energy required for air conditioning in cold weather to become suitable for the indoor environment is greater than that required for air conditioning in mild weather.

For cold day and no occupancy, there is no need to use DCV strategy, because the use of DCV in this case has no impact on energy consumption, as was on 21/2/2013, and 25/1/2013 (in appendices).

For hot days and there is occupancy, the amount of savings in energy is significant as was on 20/6/2013, because the energy required for air conditioning in hot weather to become suitable for the indoor environment is greater than that required for air conditioning in mild weather.

If there is no occupancy, there is no need to use DCV, because the use of DCV in this case has no impact on energy consumption, as was on 19/7/2013

The proposed method to calculate temperature of supply air has shown a great convergence between simulations and measurements, but, there is a deviation in some cases, as was on 20/6/2013, 8/3/2013 (in appendices) and 23/4/2013 (in appendices).

The proposed method to control humidity has shown that can keep relative humidity indoors between maximum and minimum values allowable for occupants.

Simulation results have shown that there is no condensation on the walls.

Results have shown that the savings which can be achieved in energy are in fact at the expense of the quality of air inside, but air quality remains within the allowable values appropriate for occupants. This means that in some cases can dispense with additional air quality in order to save more energy.

8 CONCLUSION

The basic physical processes within classrooms with different sizes of occupancy have been modelled using MATLAB/SIMULINK software. In order to accomplish this task, the outdoor boundary conditions had to be specified with the use of weather data obtained from the meteorological station in Brno (TUBO). These data have been converted into other form readable in the designed model. The data which have been converted into MAT files are outdoor temperature and relative humidity, so that become ready to be used directly, through exporting them to the model.

With regard to the values of the intensity of solar radiation, a sub-model has been designed by using TRNSYS software to calculate the intensity of solar radiation incident on the walls of the building, with the help of the values of temperature, relative humidity and the intensity of solar radiation taken from the meteorological station.

Modelling the indoor temperature is based on the principle of conservation of energy. The main flows of energy to and from the building through the envelope have been modelled, taking into account the internal thermal loads. Then, control strategy to control temperature using an ON-OFF controller has been designed, so that it works for heating/cooling processes, as it is required, at the same time. In direct signal, it controls heating process. After reversing of control signal, it controls cooling process, taking into account that the criterion to begin to control temperature inside the room are conditions after using supply air, but in absence of heating or cooling.

Modelling the concentration of carbon dioxide is based on the principle of conservation of mass, where, the main flows of air to and from the building have been modelled with the amount of carbon dioxide carried by these flows. Then two different control strategies have been modelled: first is the traditional strategy, while the second is demand controlled ventilation (DCV). DCV strategy uses fresh air only when the concentration of carbon dioxide reaches to the limit values. This way leads to savings in energy needed for air conditioning.

Modelling humidity is based on the principle of conservation of mass, where, the main flows of air to and from the building have been modelled with the amount of water vapour carried by these flows, taking into account the amount of water vapour originating from the people inside. Then depending on the moisture content of the maximum and minimal levels, an approximate method has been modelled to calculate the rate of water which must be added or removed, to keep relative humidity within the allowed range.

To determine the validity of the model, simulation results have been compared with the actual results taken by monitoring system installed inside the classroom known as EBI system (Enterprise Buildings Integrator).

The results have shown that the values of temperature, relative humidity and concentration of carbon dioxide within the classroom are close to the recorded values with variations that do not exceed ten percent of the maximum level. The results have shown that DCV strategy can save the energy used for heating/cooling. The amount of savings basically depends on the size of occupancy and climatic conditions outdoors. Where, in mild weather, the savings in energy are low, especially for low occupancy. While in hot/cold weather, the savings in energy are significant, even for low occupancy.

This work has presented an integrated computer model using MATLAB/SIMULINK and TRNSYS simulates the indoor environment and control its basic parameters, which are temperature, relative humidity and air quality.

Strategy temperature control has been designed using ON-OFF controller, and some methods of modelling have been applied makes the model responds automatically to the climatic conditions outdoors and can automatically determine the control signal required whether for heating or cooling, or no signal, depending on the climatic conditions outdoors as well as thermal loads and losses indoors, and is what may form the basis paves the way for the design of control systems work that way without human intervention, and can estimate the thermal load required of its own, so that thermal load will not be greater nor less than required. This is important to save energy, and at the same time can maintain the internal climate parameters under the conditions required for the convenience of the occupants.

Energy balance equations used in this work are differential equations, but with the help of Laplace transform, an environment work can be created with the help of SIMULINK suitable for other controllers.

An article has been published focused on how to create a simplified model for a residential room with the help of Laplace transform and propose a controller with tuning process using MATLAB/SIMULINK.

Another article has been published focused on how to design a simplified integrated model for an air-conditioning system.

Some strategies to control the quality of indoor air have been designed depending on the concentration of carbon dioxide indoors to investigate the impact on the cost of heating and cooling, and this is of paramount importance, especially in residential buildings that are subject to variable occupancy. But the search did not discuss the construction costs and maintenance of this process. This is necessary to assess the economic feasibility of the proposed strategy and is what paves the way for more research in the future. At the same time paves the way for finding cheap methods of control of air quality depending on the concentration of carbon dioxide because of the impact of this strategy on reducing the costs of heating and cooling. Here it should be noted that in industrial plants, there will be more factors affecting air quality. It depends on the gases emitted in those facilities.

An article has been accepted in the Journal of TZB-info, is about modelling of base/forced ventilation strategy and DCV strategy at different sizes of occupancy by using MATLAB/Simulink.

With regard to control humidity, some control strategy has been proposed based on ON-OFF controller depends on the amount of moisture which must be added or removed without the use of Psychrometric chart. This sub-model works in both directions (adding and removing moisture) and can automatically determine the signal needed to control humidity, whether adding moisture, remove moisture or no signal, and is what also essentially paves the way for the design of control systems work that way without human intervention and can estimate the latent thermal load required of its own. This is also important for energy conservation and at the same time for maintaining the internal climate parameters under the conditions required for the convenience of the occupants.

In the future, more articles about different strategies to control the operations of humidification and dehumidification will be working to publish.

The sub-model proposed to calculate the maximum/minimum temperature of supply air can help to calculate the required sensible thermal load.

The sub-model designed to detect condensation is important in buildings, especially in museums and theatres, and those where the requirements for maintaining the architecture are the utmost importance.

Model is designed in a way makes the separation and installation of parts (sub-models) of the building and modification is possible. Where it is easy to separate each part, then modify it and re install in the model without affecting the other sub-models.

Through the model, the annual energy consumption required for air conditioning process can be estimated.

Simulation runs quickly and saves a lot of effort and time to solve the differential equations which form the basis of mathematical models. Further, model can be developed in order to include more than one building.

These features could form the basis for the development of the model in the future to include a wide range of tasks relating to air conditioning and to estimate the costs as well as potential savings of energy.

Currently an article about modelling the indoor temperature using MATLAB and TRNSYS is being prepared to publish.

References

- [1] HOLOPAINEN, Riika. *A human thermal model for improved thermal comfort*. Ph.D. thesis, VTT Technical Research Centre of Finland, 2012.
- [2] Fu, G. *A Transient 3-D Mathematical Thermal Model for the Clothed Human*. Ph.D. thesis, Kansas State University, 1995.
- [3] HENSEL, Herbert. *Thermoreception and temperature regulation*. London; New York: Academic Press: Monographs of the Physiological Society, no. 38, 1981. ISBN 0123412609.
- [4] ZHANG, Hui. *Human thermal sensation and comfort in transient and nonuniform thermal environments*. Ph.D. thesis, University of California at Berkeley, 2003.
- [5] HENSEN, J.L.M. *On the thermal interaction of building structure and heating and ventilation system*. Ph.D. thesis, Eindhoven University of Technology, 1991.
- [6] ASHRAE Standard 55-1992, *Thermal Environmental Conditions for Human Occupancy*.
- [7] LACKER, K.S. Capture of Carbon Dioxide from ambient air. *The European Physical Journal Special Topics*, 2009, 176(1), 93–106.
- [8] Office of Environmental Health. *Public Health Evaluation of Indoor Air Quality, Self-Reported Illnesses, and Tumors Corona del Sol High School, Tempe, Arizona*. Arizona. 2008.
- [9] M. Krzaczek and J. Tejchman (2012). Indoor Air Quality and Thermal Comfort in Naturally Ventilated Low-Energy Residential Houses, *Air Quality - Monitoring and Modeling*, Dr. Sunil Kumar (Ed.), ISBN: 978-953-51-0161-1, InTech, DOI: 10.5772/33227. Available from: <http://www.intechopen.com/books/air-quality-monitoring-and-modeling/air-quality-in-low-energy-buildings>
- [10] SHENDELL, DG., RP. PRILL, WJ. Fisk, MG. Apte, D. Blake and D. Faulkner. *Associations between classroom CO₂ concentrations and student attendance*. Berkeley, CA: E.O. Lawrence Berkeley National Laboratory, August 2003. LBNL–53586.
- [11] SHAUGHNESSY, R.J., U. HAVERINEN-SHAUGHNESSY, A. NEVALAINEN and D. MOSCHANDREAS. A preliminary study on the association between ventilation rates in classrooms and student performance. *Indoor Air*, 2006, 16(6), 465–468.
- [12] WARGOCKI, P. and D.P. WYON. The effect of moderately raised classroom temperatures and classroom ventilation rate on the performance of schoolwork by children. *HVAC&R Research*, 2007, 13(2), 193–220.
- [13] MENDELL, MJ. and GA. Heath. Do indoor pollutants and thermal conditions in schools influence student performance? A critical review of the literature. *Indoor Air*, 2005, 15(1), 27–52.
- [14] BAKO-BIRO, Zs., N. KOCHLAR, D.J. CLEMENTS-CROOME, H.B AWBI and M. Williams. Ventilation Rates in Schools and Learning Performance. In *Proceedings of CLIMA 2007-WellBeing Indoors, the 9th REHVA World Congress*. Helsinki, Finland, pp. 1434–1440.

- [15] ASHRAE Standard 62.1–2004, *Ventilation for acceptable indoor air quality*, ASHRAE, Atlanta, GA, USA.
- [16] GODWIN, C. and S. BATTERMAN. Indoor air quality in Michigan schools. *Indoor Air*, 2007, 17(2), 109–121.
- [17] ARUNDEL, AV., EM. STERLING, JH. BIGGIN and TD. STERLING. Indirect effects of relative humidity in indoor environments. *Environ Health Perspect*, 1986, 65, 351–361.
- [18] VALEN, MS. *Moisture Transfer in Organic Coatings on Porous Materials*. Ph.D. thesis, Norwegian University of Science and Technology, 1998.
- [19] NAGDA, NL. and HE. RECTOR. A critical review of reported air concentrations of organic compounds in aircraft cabins. *Indoor Air*, 2003, 13, 292–301.
- [20] DOTY, RL., JE. COMETTO-MUNIZ, AA. JALOWAYSKI, P. DALTON, M. KENDALL-REED and M. HODGSON. Assessment of upper respiratory tract and ocular irritative effects of volatile chemicals in humans. *Crit Rev Toxicol*, 2004, 34, 85–142.
- [21] BURGE, PS. Sick building syndrome. *Occup Environ Med*, 2004, 61, 185–90.
- [22] ANDERSEN, I., GR. LUNDQVIST, PL. JENSEN and DF. PROCTOR. Human responses to 78-hour exposure to dry air. *Arch Environ Health*, 1974, 29(6), 319–24.
- [23] CAIN, W.S., R. SCHMIDT, B.P. LEADERER, J.F. GENT, D. BELL and L.G. BERGLUND. Emission of VOCs from materials used in buildings: analytical and sensory aspects. *ASHRAE Transactions*, 2002, 180, 283–96.
- [24] FANGER, PO. Indoor air quality in the 21st century: search for excellence. *Indoor Air*, 2000, 10, 68–73.
- [25] *Building Air Quality: A Guide for Building Owners and Facility Managers*– EPA, 1998. Indoor Air Quality Information Clearinghouse, P.O. Box 37133, Washington, D.C. 20013-7133; 1-800-438-4318.
- [26] HOLMAN, Jack Philip. *Heat Transfer*. 10th ed. New York: McGraw-Hill, 2010. ISBN 978–0–07–352936–3.
- [27] LIENHARD IV, John H and John H LIENHARD V. *A Heat Transfer Textbook*. 3^d ed. Cambridge, Massachusetts, U.S.A.: Phlogiston Press, 2008.
- [28] ASADI, Somayeh, Marwa HASSAN and Ali BEHESHTI. Residential Attic with Radiant Barrier System: Finite Element Simulation and Parametric Study. *48th ASC Annual International Conference Proceedings*. Birmingham, England, 2012.
- [29] JANNA, William S. *Engineering Heat Transfer*. Boca Raton, Florida: CRC Press LLC, 2000. 2^d ed. ISBN 0-8493-2126-3.
- [30] KUTZ, Myer. *Heat Transfer Calculations*. 1st ed. USA: McGraw-Hill Professional, 2005. ISBN-10: 0071410414.
- [31] JAMIL AHMAD, M., G.N. TIWARI, Singh ANIL KUMAR, Sharma MANISHA and H.N. SINGH. Heating/Cooling Potential and Carbon Credit Earned for Dome Shaped House. *International Journal of Energy and Environment*. 2010, 1(1), 133–148. ISSN 2076-2895.
- [32] EUREF. The International Association of Geodesy Reference Frame Sub-Commission for Europe, 1987 [viewed 15 June 2012]. Available from: <http://www.euref.eu/>

- [33] TUBO. Technical University Brno, (Permanent GPS stations), 1994 [viewed 10 June 2012]. Available from: <http://tubo.fce.vutbr.cz/new/>
- [34] *Geodetic observatory Pecný*. The Department of Geodesy and Geodynamics of the Research Institute of Geodesy, Cartography and Topography (VUGTK), 1992 [viewed 10 July 2012]. Available from: <http://pecny.asu.cas.cz/Joomla/>
- [35] MathWorks. The MathWorks, Inc. 1984, [viewed 10 October 2011]. Available from: <http://www.mathworks.com>
- [36] KLEIN, S.A., et al. TRNSYS 16 – A Transient System Simulation Program. University of Wisconsin-Madison Solar Energy Laboratory, Madison, WI, USA. 2007.
- [37] TRNSYS-17 manual, Volume 1: Getting Started, 2009.
- [38] DUFFIE, John A and William A BECKMAN. *Solar Engineering of Thermal Processes*. Wiley, 2006. 3^d ed. ISBN-10: 0471698679.
- [39] RADOSAVLJEVIĆ, Jasmina and Amelija ĐORĐEVIĆ. Defining of the Intensity of Solar Radiation on Horizontal and Oblique Surfaces on Earth. *Working and Living Environmental Protection*, 2001, 2(1), 77–86.
- [40] AL-RAWAHI, N.Z, Y.H. ZURIGAT and N.A. AL-AZRI. Prediction of Hourly Solar Radiation on Horizontal and Inclined Surfaces for Muscat/Oman. *The Journal of Engineering Research*, 2011, 8(2), 19–31.
- [41] ROPPEL, P.J., M.D. LAWTON and B. HUBBS. Balancing the control of heat, air, moisture, and competing interests. *Proceedings of the 11th Canadian Conference on Building Science and Technology Conference*. Banff, Alberta. 2007.
- [42] ELLIS, M.W. and E.H. MATHEWS. Needs and trends in building and HVAC system design tools, *Building and Environment*, 2002, 37(5), 461–470.
- [43] AUGENBROE, G. Trends in building simulation, *Building and Environment*, 2002, 37, 891-902.
- [44] HENSEN, Jan, Ery DJUNAEDYD, Marija RADOSEVIC and Azzedine YAHIAOUI. Building performance simulation for better design: some issues and solutions. *21TH PLEA Conference*. Eindhoven. 2004.
- [45] CARK, D.R. *HVACSIM+ Building Systems and Equipment Simulation Program Reference Manual*. Gaithersburg, MD 20899: the U.S. Department of Commerce, National Bureau of Standards, National Engineering Laboratory, Center for Building Technology, Building Equipment Division, 1985.
- [46] LEGHMIZI, Said and Latifa BOUMEDIENE (2011). Modeling and Control of Mechanical Systems in Simulink of Matlab, *Applications of MATLAB in Science and Engineering*, Prof. Tadeusz Michalowski (Ed.), ISBN: 978-953-307-708-6, InTech.
- [47] ASHINO, R., M. NAGASE and R. VAILLANCOURT. Behind and beyond the MATLAB ODE suite. *Computers & Mathematics with Applications*, 2000, 40, 491–512.

- [48] SASIC KALAGASIDIS, A. *The whole model validation for HAM-Tools. Case study: hygro-thermal conditions in the cold attic under different ventilation regimes and different insulating materials*. Report R:03-6. Department of Building Technology, Chalmers University of Technology, Gothenburg, Sweden. 2003.
- [49] SOLEIMANI-MOHSENI, Mohsen. *Modelling and intelligent climate control of buildings*. Ph.D. thesis, Chalmers University of Technology, 2005.
- [50] ZHONG, Zhipeng and James E. BRAUN. *Combined heat and moisture transport modelling for residential buildings*. Indiana, Purdue University. 2008.
- [51] RUTKOWSKI, Hank. *Manual: Residential Load Calculation*, 1986, 7th ed. Air Conditioning Contractors of America, Arlington, VA.
- [52] EMMERICH, S.J and A.K. PERSILY. *State-of-the-Art Review of CO₂ Demand Controlled Ventilation Technology and Application*. NISTIR 6729, National Institute of Standards and Technology, 2001.
- [53] APTE, M.G. A review of demand controlled ventilation. *In Proceedings of Healthy Buildings 2006*: Universidade de Porto, Portugal. IV: 371–376.
- [54] BRANDEMUEHL, M.J. and J. E. BRAUN. The impact of demand controlled and economizer ventilation strategies on energy use in buildings. *ASHRAE Transactions*, 1999, 105(2), 39-50
- [55] CHEN, Y. Lisa and Jin WEN. Estimating a Building Airflow Network using CO₂ Measurements from a Distributed Sensor Network. *International High Performance Buildings Conference at Purdue, July 2010*. Purdue: Purdue e-Pubs, a service of the Purdue University Libraries.
- [56] Joseph M. POWERS. *Lecture Notes on Thermodynamics*. University of Notre Dame, 2013.
- [57] HARRIMAN, L., G. BRUNDRETT and R. KITTLER. *Humidity Control Design Guide for Commercial and Institutional Buildings*, ASHRAE, Atlanta, GA. 2001.
- [58] BAUGHMAN, A., and E. ARENS. Indoor Humidity and Human Health—Part I: Literature Review of Health Effects of Humidity-Influenced Indoor Pollutants. *ASHRAE Transactions*, Vol. 101, Pt. 1, 1996.
- [59] HASHIGUCHI, N., M. HIRAKAWA, Y. TOCIHARA, Y. KAJI and C. KARAKI. Effects of setting up of humidifiers on thermal conditions and subjective responses of patients and staff in a hospital during winter. *Applied Ergonomics*, 2008, 39(2), 158–165.
- [60] HEMMERS, J.H., K.C. WINKLER and S.M. KOOL. Virus survival as a seasonal factor in influenza and poliomyelities. *Nature*, 1960, vol. 188, 4748, pp. 430–431
- [61] HIRAGA, Y., R. MIKAMI, M. KAJI, I. MIZOGUCHI, S. KUDO and T. SATAKE. Clinical epidemiological study on the use of ultrasonic humidifier in low-humidity rooms of apartment buildings heated by a central heating system. *Jpn. J. Thorac.* 1981, (9), 631–640.
- [62] McNeel, SV. and RV. KREUTZER. Fungi & Indoor Air Quality. *Health & Environment Digest*, 1996, 10(2), 9–12.

- [63] HAVERINEN, U., M. VAHTERISTO et al. Knowledge-based and Statistically Modeled Relationships between Residential Moisture Damage and Occupant Reported Health Symptoms. *Journal of Atmospheric Environment*, 2003, 37, 577–585.
- [64] TOM, RW. Wall Moisture Problems in Alberta Dwellings. *Canada Mortgage and Housing Corporation (CMHC)*. Canada, 2001.
- [65] HAGENTOFT, CE., A.S. KALAGASIDIS, B. ADL-ZARRABI, S. ROELS, J. CARMELIET, H. HENS, J. GRUNEWALD, M. FUNK, R. BECKER, D. SHAMIR, O. ADNAN, H. BROCKEN, K. KUMARAN and R. DJEBBAR. Assessment Method of Numerical Prediction Models for Combined Heat, Air and Moisture Transfer in Building Components: Benchmarks for One-dimensional Cases. *Journal of Thermal Envelope and Building Science*, 2004, 27, 327–352.
- [66] KALAGASIDIS, AS. *HAM-Tools, International Building Physics Toolbox, Block documentation, R-02:6*, Department of Building Physics, Chalmers University of Technology, Gothenburg, Sweden, 2002.
- [67] SCHELLEN, HL. and AWM. VAN SCHIJNDEL. Application of an Integrated Indoor Climate & HVAC Model for the Indoor Climate Performance of a Museum. *The 7th Symposium on Building Physics in the Nordic Countries*. Reykjavik, Iceland, 2005.
- [68] RODE, C, K. GRAU and T. MITAMURA. Hygrothermal Conditions in the Envelope and Indoor Air of Buildings. *Performance of Exterior Envelopes of Whole Buildings VIII Conference*. Florida, 2001.
- [69] SANDERS, C. *Heat, Air and Moisture Transfer in Insulated Envelope Parts, Final Report, vol. 2: Environmental Conditions*, International Energy Agency. Annex 24, Laboratory for Building Physics, Catholic University. Leuven, Belgium, 1996.
- [70] WANG, S.K. and Z. LAVAN. *Air-Conditioning and Refrigeration*. Mechanical Engineering Handbook Ed. Frank Kreith Boca Raton: CRC Press LLC, 1999.
- [71] DHARMA RAO, V, V. MURALI KRISHNA, KV. SHARMA and PVJM. RAO. Convective condensation of vapour in the presence of a non-condensable gas of high concentration in laminar flow in a vertical pipe. *International Journal of Heat and Mass Transfer*, 2008, 51(25-26), 6090–6101.
- [72] BERGMAN, Theodore L, Adrienne S LAVINE and Frank P INCROPERA. *Fundamentals of heat and mass transfer*. USA: Wiley, 2011. ISBN SBN-10: 0470501979.
- [73] WANGER, W. and A. PRUB. The IAPWS Formulation 1995 for the Thermodynamic Properties of Ordinary Water Substance for General and Scientific Use. *Journal of Physical and Chemical Reference Data*, June 2002, 31(2), 387–535.
- [74] *Humidity Conversion Formulas*. FI-00421 Helsinki, Finland: Vaisala Oyj, 2013.
- [75] Enterprise Buildings Integrator Operators Guide. Honeywell Limited Australia, 2005.

List of publications of author

- [A1] MOHAMAD, M. Preliminary Design and Thermal Study of a Solar Pond Used to Heat a Tourist Hotel. 30. *Setkání kateder mechaniky tekutin a termomechaniky 2011*. pp. 167-170. ISBN 978-80-7372-747-5.
- [A2] MOHAMAD, M. Developing of a Thermal Model for a Residential Room Using Simulink/Matlab. 31. *Setkání kateder mechaniky tekutin a termomechaniky 2012*. pp. 157-160. ISSN 978-80-214-4529-1.
- [A3] MOHAMAD, M. Design a Simplified Model of HVAC System Within a Residential Building by Using MATLAB/ SIMULINK. In Brno: IBPSA - CZ (The International Building Performance Simulation Association - Czech Republic), 2012. ISBN: 978 80-260-3392-9.
- [A4] MOHAMAD, Mohamad Kheir and Julia WEISMANOVÁ. Modelovanie vetracích systémov s konštantným prietokom vzduchu a systémov riadených skutočnou potrebou v programe MATLAB/Simulink. *TZB-info*, 2014, ISSN: 1801-4399. (In print).

List of symbols and abbreviations

Symbol	Nomenclature	Unit
A	Area	m ²
C _{in}	Indoor CO ₂ concentration	mg/m ³ (ppm)
C _{out}	Outdoor CO ₂ concentration	mg/m ³ (ppm)
c _p	Specific heat capacity for constant pressure	J/kg.K
E	Heat (Energy)	J
E _o	Emitted energy rate	W
G	Indoor CO ₂ generation rate	mg/s (m ³ /s)
h	Convection heat transfer coefficient	W/m ² K
I	Solar radiation	W/m ²
I _d	Mean hourly diffuse solar radiation	W/m ²
I _g	Mean hourly global solar radiation	W/m ²
I _T	Hourly incident solar radiation	W/m ²
k	Thermal conductivity	W/m.K
l	Thickness	m
m; M	Mass; mass flow	kg; kg/s
N	Air change rate	1/h
P	Pressure	Pa
P _s	Saturation pressure	Pa
P _w	Water vapour pressure	Pa
Q _v	Ventilation rate	mg/s (m ³ /s)
\dot{Q}	Heat transfer rate	W = J/s
R	Gas constant	J/kg.K

RH	Relative humidity	%
R_i	Thermal resistance of element i	$m^2 K/W$
r	Global radiation tilt factor	-
r_b	Hourly geometric factor	-
SC	Solar heat gain coefficient	-
T	Temperature	$^{\circ}C, K$
T_{so}	Sol-air temperature	$^{\circ}C, K$
t	Time	s
U	Overall heat transfer coefficient	$W/m^2 K$
V	Volume	m^3
W	Humidity content	kg/kg
x	Distance	m
α	Absorptance	-
β	Slope	$^{\circ}$
γ	Surface azimuth angle	$^{\circ}$
δ	Declination angle	$^{\circ}$
ε	Emissivity	-
Θ	Incidence angle	$^{\circ}$
Θ_z	solar zenith angle	$^{\circ}$
ρ	Density	kg/m^3
ρ_s	Reflectivity	-
ϕ	Latitude of a location	$^{\circ}$
ω	Hour angle	$^{\circ}$

List of physical constants

Constant	Unit
Solar constant	$I_{sc}=1367 \text{ W/m}^2$
Gas constant	$R_{air}=287 \text{ J/kg.K}$
Stefan – Boltzmann constant	$\sigma = 5,67051 \times 10^{-8} \text{ W/m}^2.\text{K}^4$

List of Appendices

Appendix 1

Results of other days in Figure 7, which they are the following days:

September 27/9/2012

November 12/11/2012

January 25/1/2013

March 8/3/2013

April 23/4/2013

September 27/9/2012

Period	11:06:00-12:12:00
mass flow of supply air	0.75kg/s
mass flow of fresh air	0.225 kg/s
maximum heater temperature	22 °C (no heating nor cooling)
occupancy	18

Simulation result for the actual strategy used in building

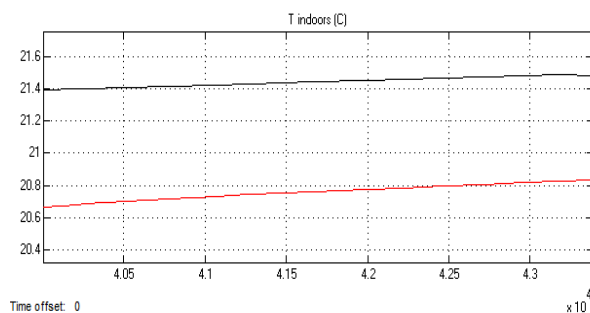

Modelling $T_{\text{conditioner}}: T_{\text{conditioner}} = 22 \text{ } ^\circ\text{C}$

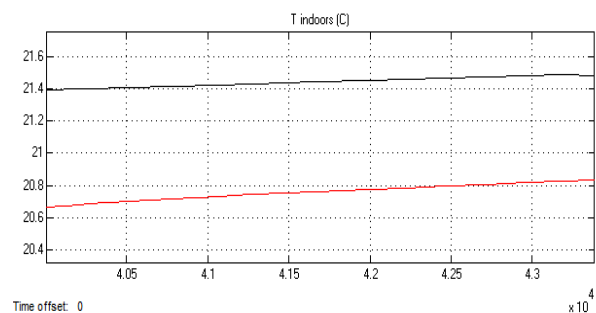

Red: simulation result for the actual strategy used in building
Black: values monitored by Honeywell system

Modelling temperature

Relative humidity before conditioning

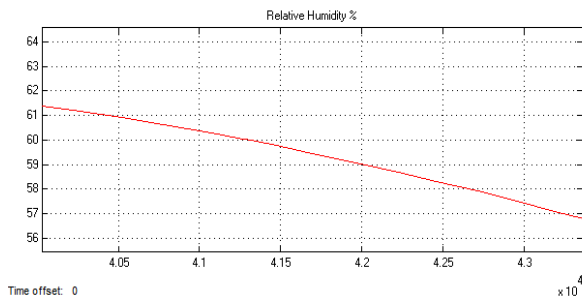

Humidity ratio before conditioning

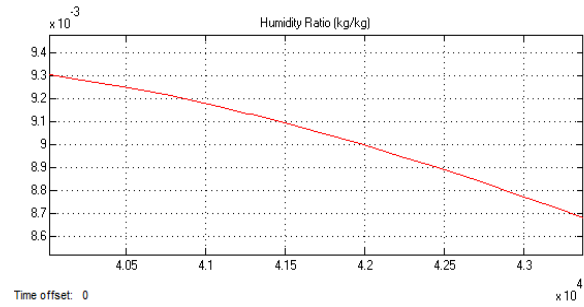

After conditioning: 0.00077 kg/s removed water

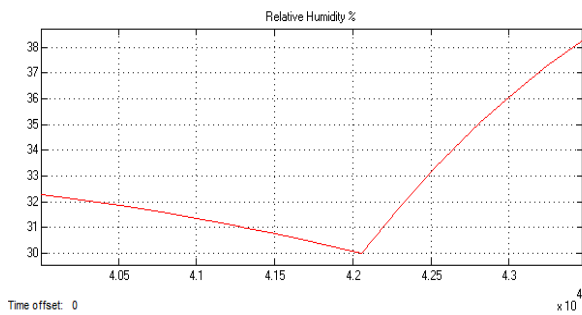

After conditioning: 0.00077 kg/s removed water

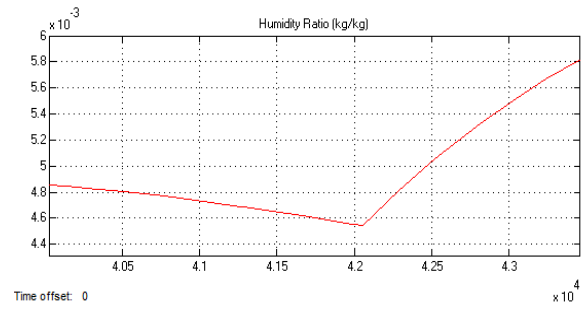

Modelling humidity

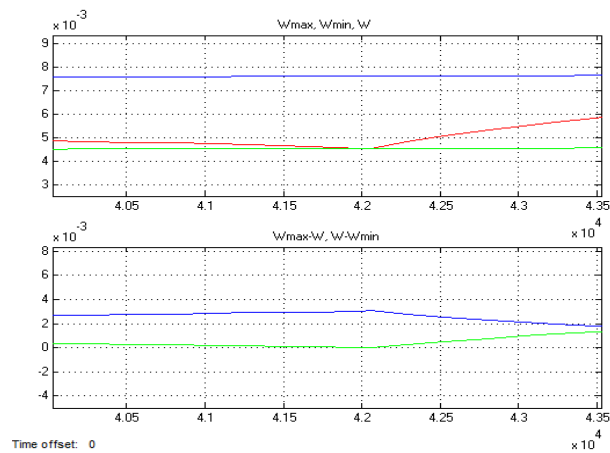

Blue top: W_{\max}
 Green top: W_{\min}
 Red: W
 Blue lower: $W_{\max} - W$
 Green lower: $W - W_{\min}$

Verification of humidity control

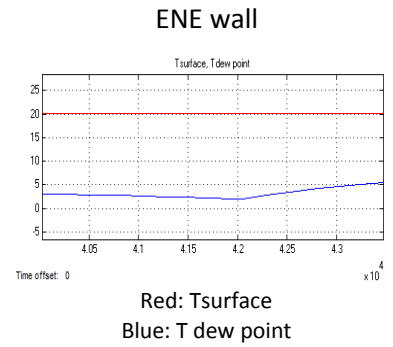
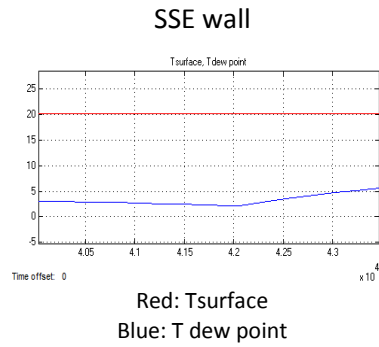
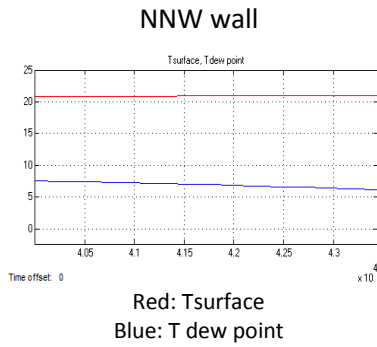

Comparison of T_{surface} and T_{dew point} for the external walls (condensation risk)

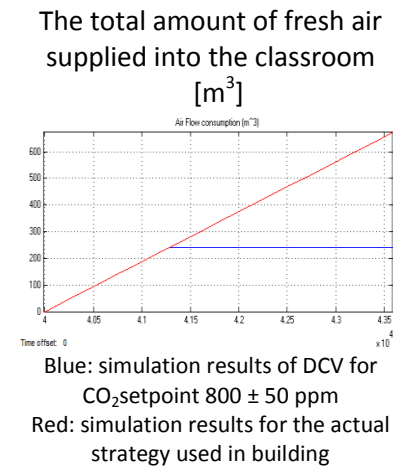
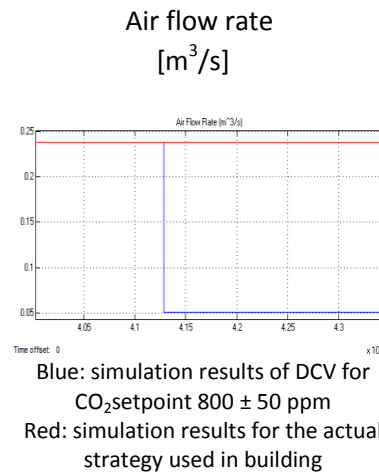
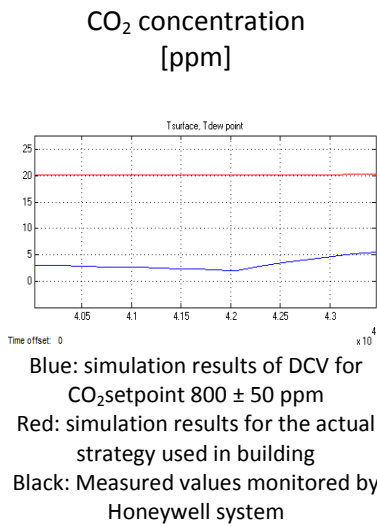

Modelling ventilation

November 12/11/2012

Period	13:44:00-14:40:00
mass flow of supply air	3 kg/s
mass flow of fresh air	1.5 kg/s
maximum heater temperature	21 °C
occupancy	83

Simulation result for the actual strategy used in building

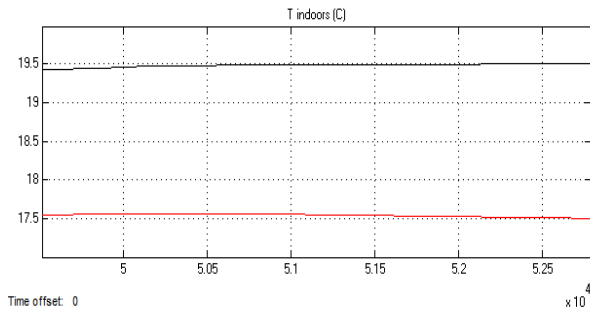

Modelling $T_{\text{conditioner}}$: $T_{\text{conditioner}} = 22\text{ °C}$

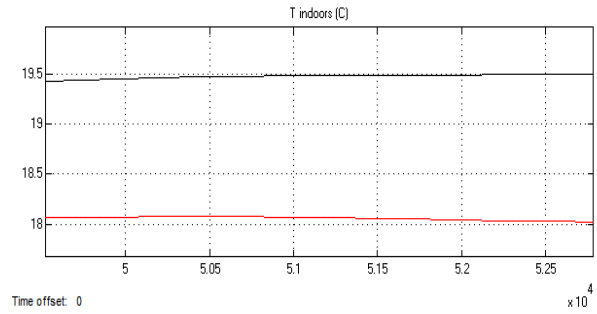

Red: simulation result for the actual strategy used in building
 Black: values monitored by Honeywell system

Modelling temperature

Relative humidity before conditioning

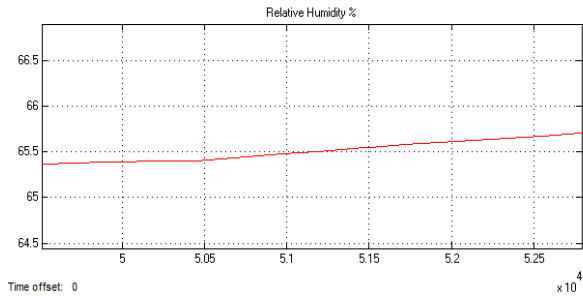

Humidity ratio before conditioning

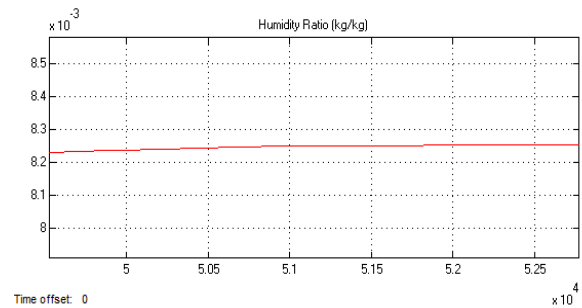

After conditioning: 0.0036 kg/s removed water

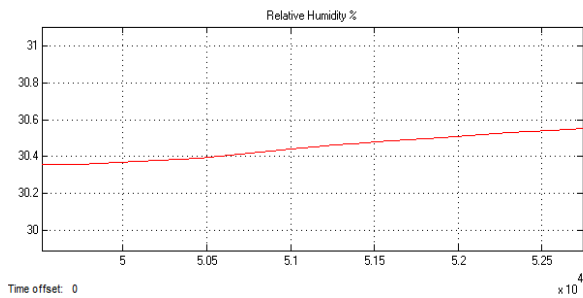

After conditioning: 0.0036 kg/s removed water

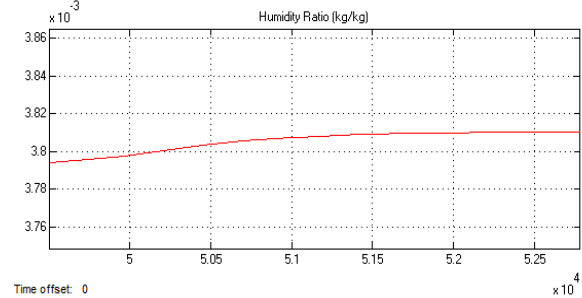

Modelling humidity

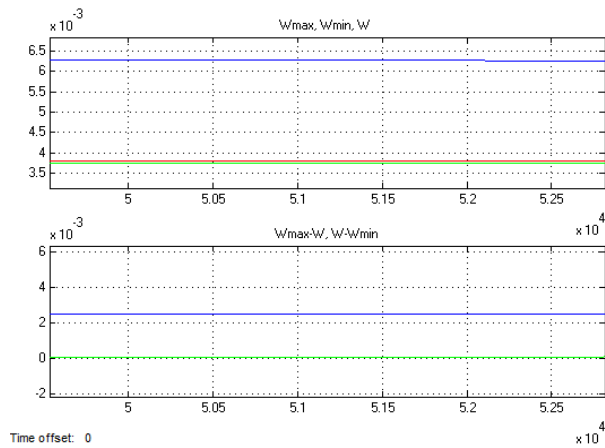

Blue top: W_{max}
 Green top: W_{min}
 Red: W
 Blue lower: $W_{max}-W$
 Green lower: $W-W_{min}$

Verification of humidity control

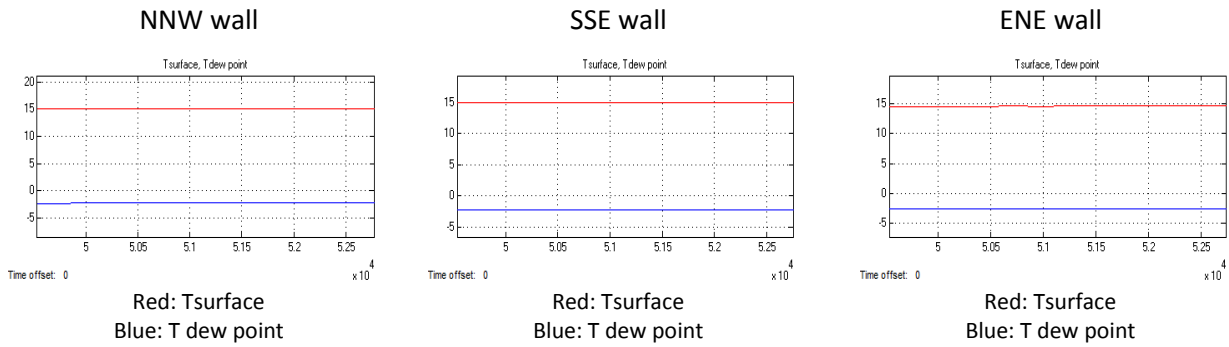

Comparison of $T_{surface}$ and $T_{dew point}$ for the external walls (condensation risk)

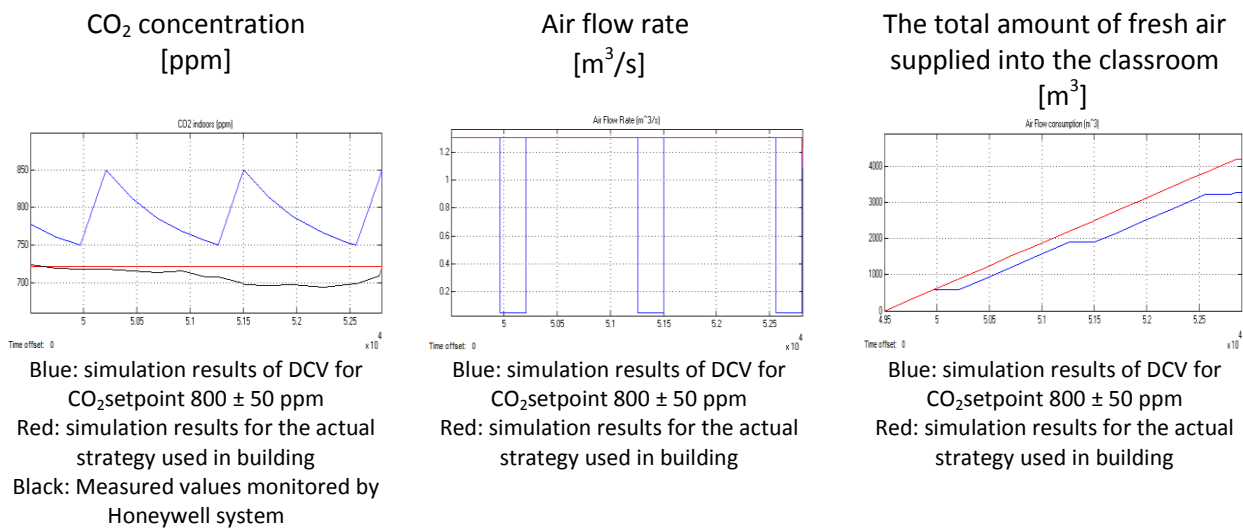

Modelling ventilation

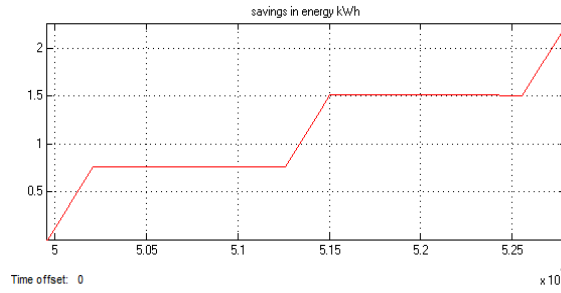

Savings in energy for heating/cooling by using DCV

January 25/1/2013

Period	14:25:00- 15:05:00
mass flow of supply air	0.75 kg/s
mass flow of fresh air (base rate)	0.225 kg/s
maximum conditioner temperature	46 °C
number of occupants	0

Simulation result for the actual strategy used in building

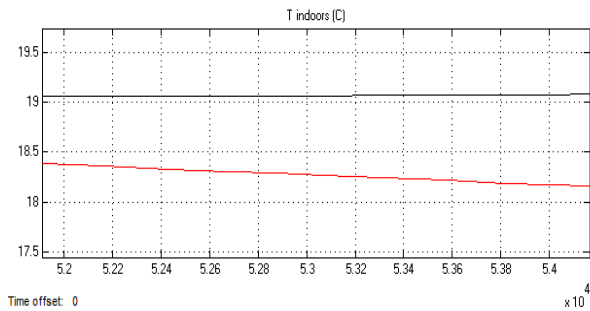

Modelling T_{conditioner}: T_{conditioner} =46 °C

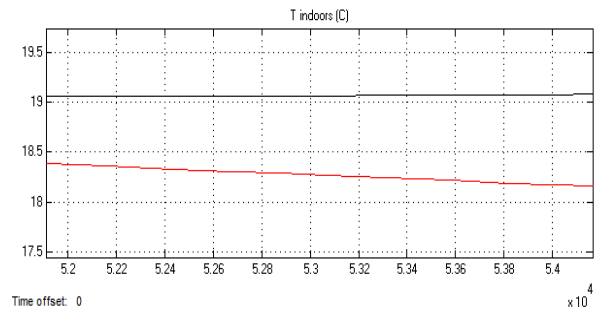

Red: simulation result for the actual strategy used in building
 Black: values monitored by Honeywell system

Modelling temperature

Relative humidity before conditioning

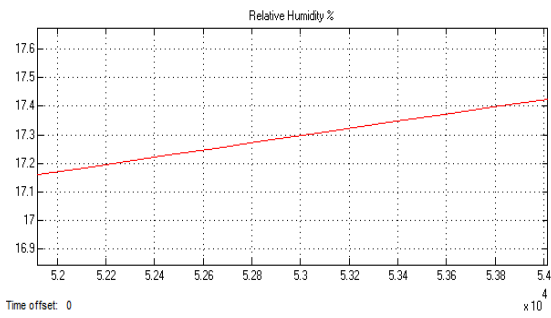

Humidity ratio before conditioning

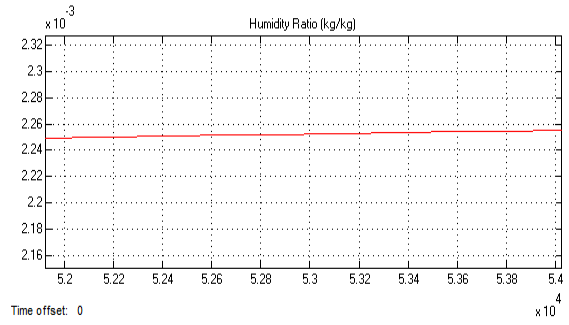

After conditioning: 0.0012 kg/s added water

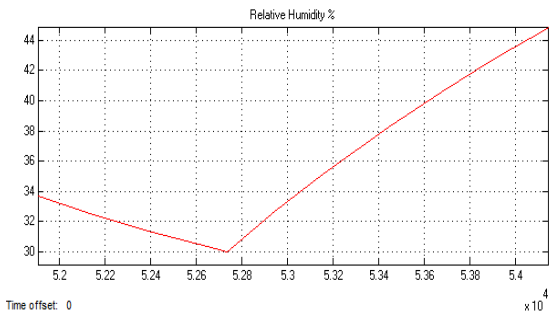

After conditioning: 0.0012 kg/s added water

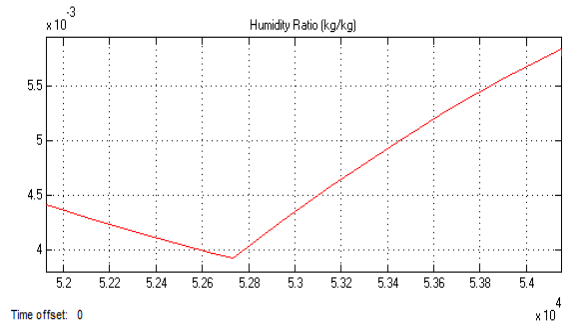

Modelling humidity

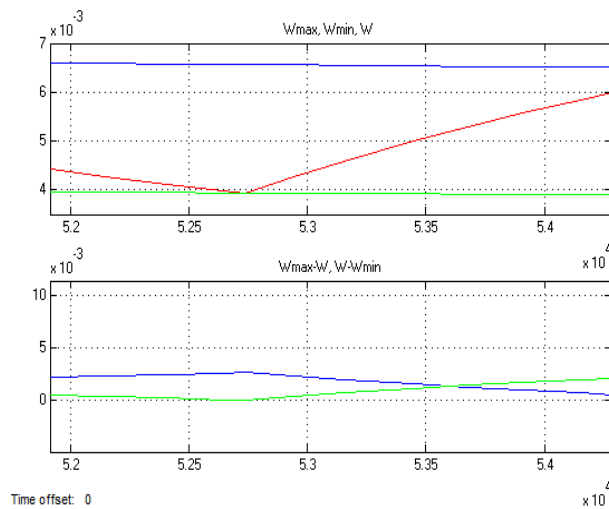

Blue top: W_{max}
 Green top: W_{min}
 Red: W
 Blue lower: $W_{max}-W$
 Green lower: $W-W_{min}$

Verification of humidity control

NNW wall

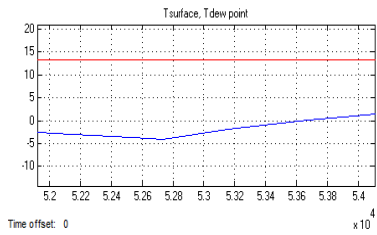

Red: T_{surface}
Blue: T_{dew point}

SSE wall

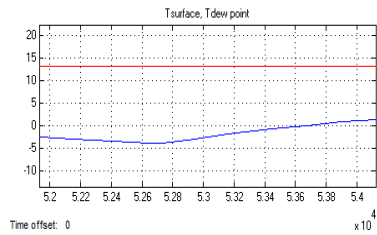

Red: T_{surface}
Blue: T_{dew point}

ENE wall

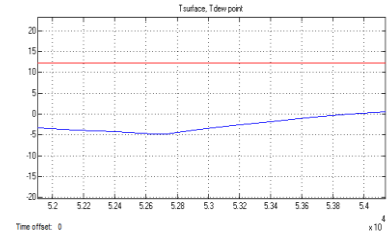

Red: T_{surface}
Blue: T_{dew point}

Comparison of T_{surface} and T_{dew point} for the external walls (condensation risk)

CO₂ concentration [ppm]

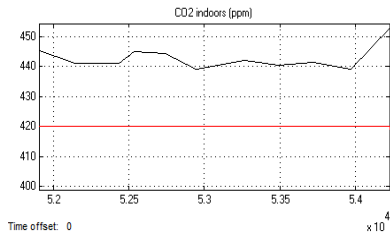

Red: simulation result for the actual strategy used in building
Black: values monitored by Honeywell system

Air flow rate [m³/s]

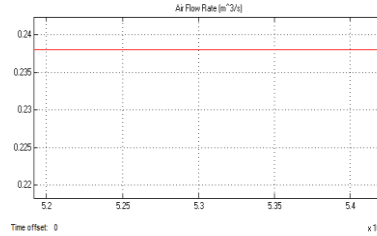

Red: simulation results for the actual strategy used in building

The total amount of fresh air supplied into the classroom [m³]

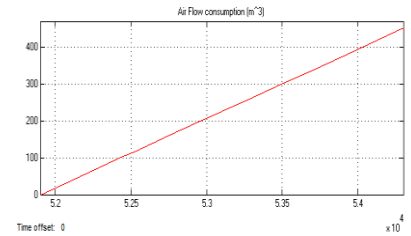

Red: simulation results for the actual strategy used in building

Modelling ventilation

March 8/3/2013

Period	13:45:00-14:35:00
mass flow of supply air	0.75 kg/s
mass flow of fresh air (base rate)	0.225 kg/s
maximum heater temperature	35 °C
occupancy	0%

Simulation result for the actual strategy used in building

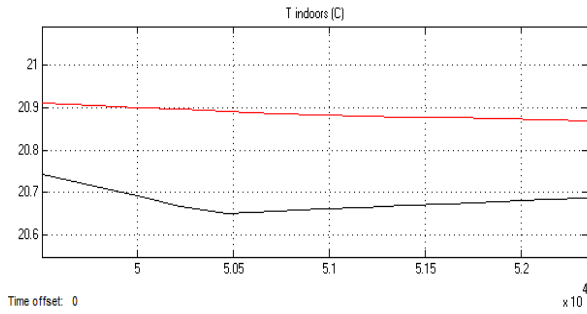

Modelling $T_{conditioner}$: $T_{conditioner} = 33\text{ °C}$

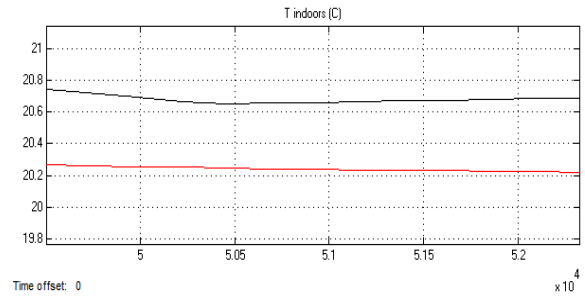

Red: simulation result for the actual strategy used in building
 Black: values monitored by Honeywell system

Modelling temperature

Relative humidity before conditioning

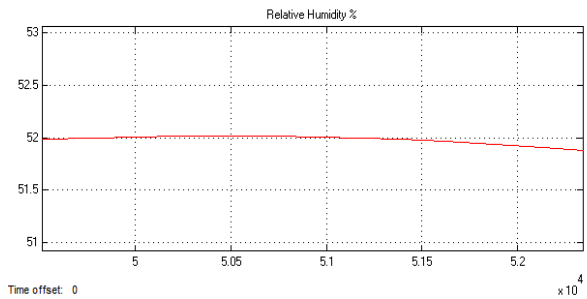

Humidity ratio before conditioning

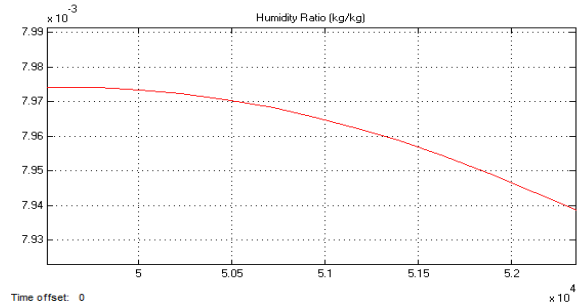

After conditioning: 0.0002 kg/s removed water

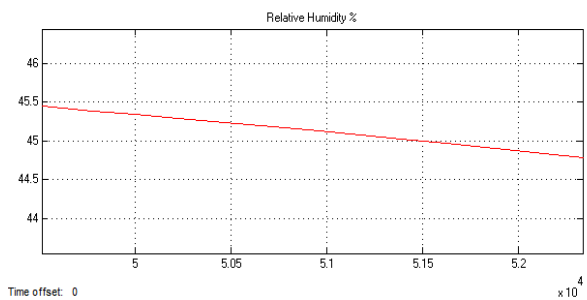

After conditioning: 0.0002 kg/s removed water

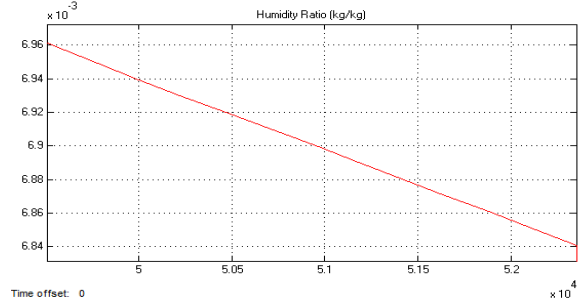

Modelling humidity

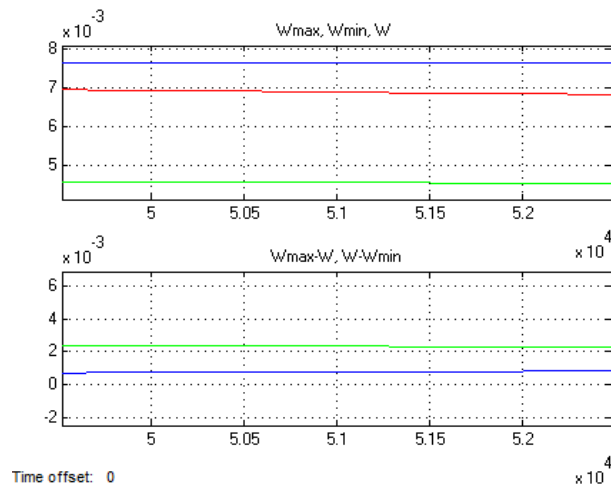

Blue top: W_{max}
 Green top: W_{min}
 Red: W
 Blue lower: $W_{max}-W$
 Green lower: $W-W_{min}$

Verification of humidity control

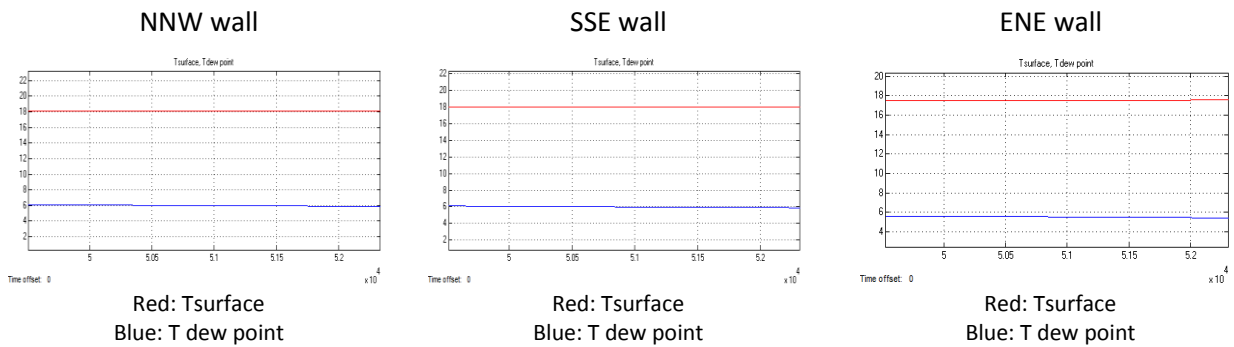

Comparison of $T_{surface}$ and $T_{dew point}$ for the external walls (condensation risk)

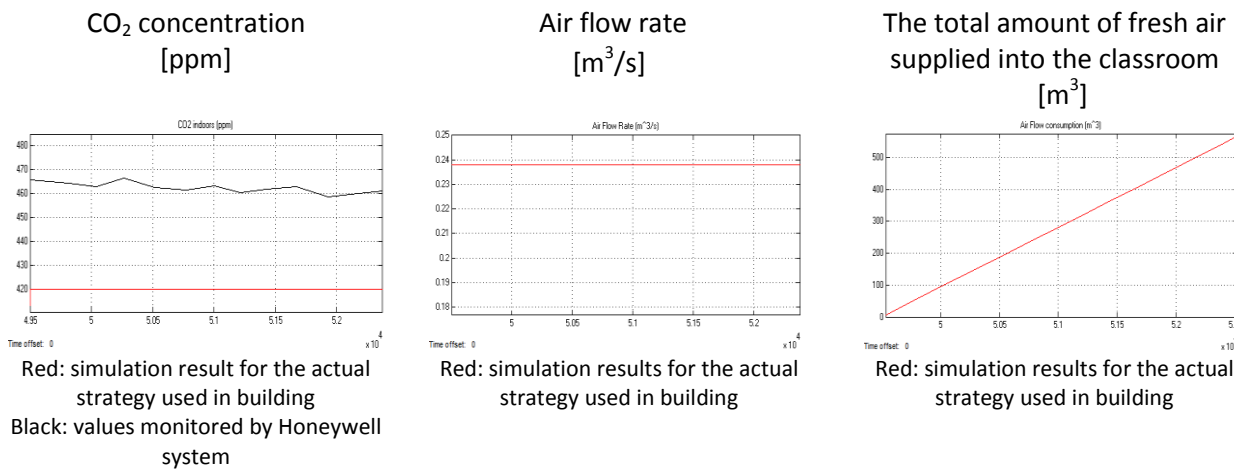

April 23/4/2013

Period	9:10:00-10:50:00
mass flow of supply air	2.885kg/s
mass flow of fresh air	1.18 kg/s
conditioner temperature	20 °C
occupancy	40

Simulation result for the actual strategy used in building

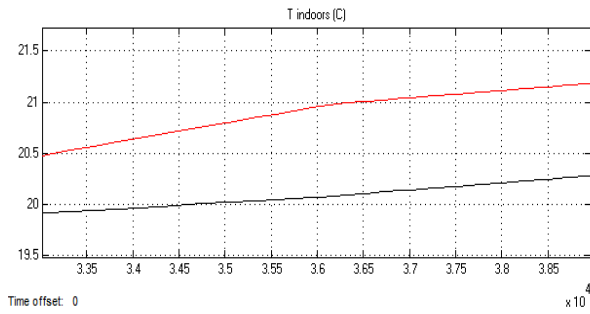

Modelling T_{conditioner}: T_{conditioner} = 17 °C

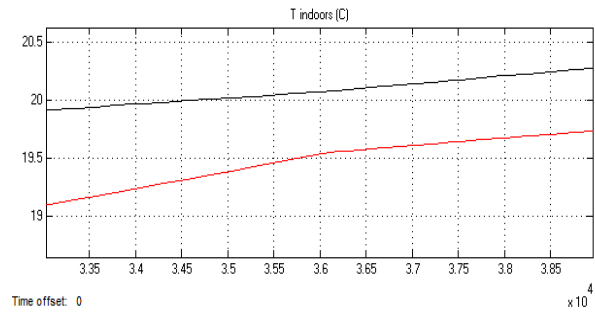

Red: simulation result for the actual strategy used in building
Black: values monitored by Honeywell system

Modelling temperature

Relative humidity before conditioning

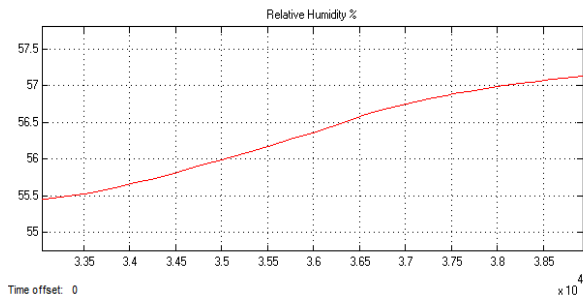

Humidity ratio before conditioning

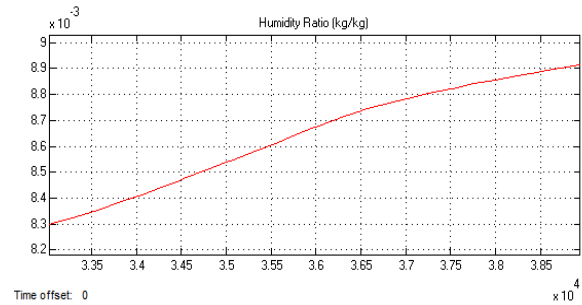

After conditioning: 0.0014 kg/s removed water

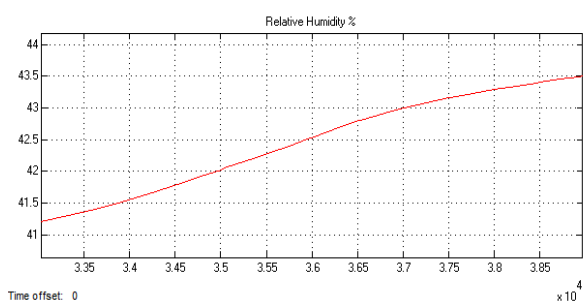

After conditioning: 0.0014 kg/s removed water

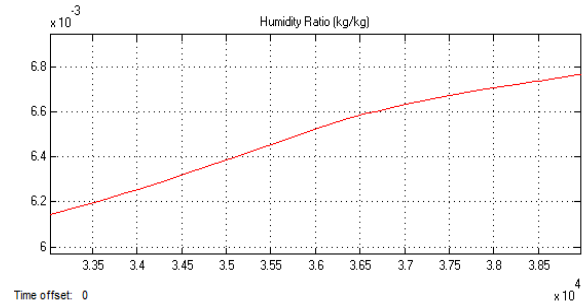

Modelling humidity

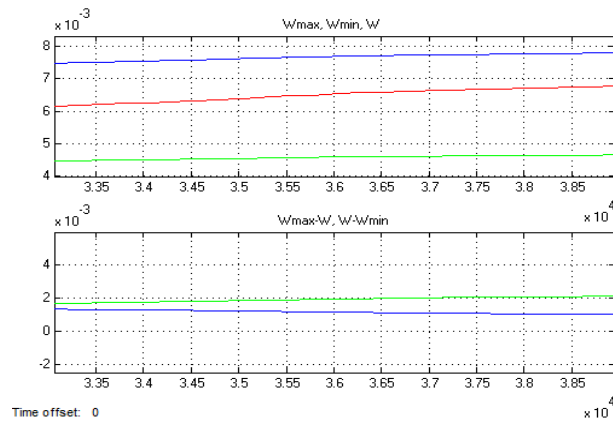

Blue top: W_{max}
 Green top: W_{min}
 Red: W
 Blue lower: $W_{max}-W$
 Green lower: $W-W_{min}$

Verification of humidity control

NNW wall

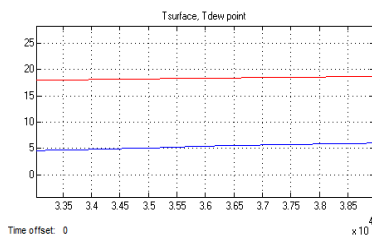

Red: $T_{surface}$
 Blue: $T_{dew\ point}$

SSE wall

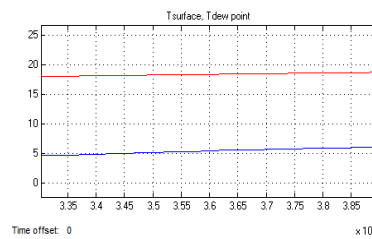

Red: $T_{surface}$
 Blue: $T_{dew\ point}$

ENE wall

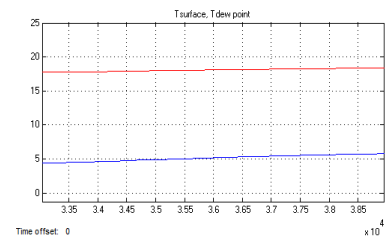

Red: $T_{surface}$
 Blue: $T_{dew\ point}$

Comparison of $T_{surface}$ and $T_{dew\ point}$ for the external walls (condensation risk)

CO₂ concentration [ppm]

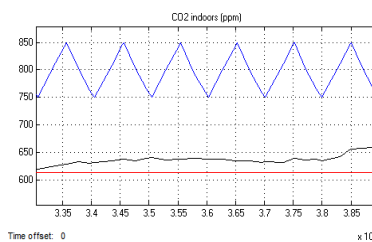

Blue: simulation results of DCV for CO_2 setpoint 800 ± 50 ppm
 Red: simulation results for the actual strategy used in building
 Black: Measured values monitored by Honeywell system

Air flow rate [m^3/s]

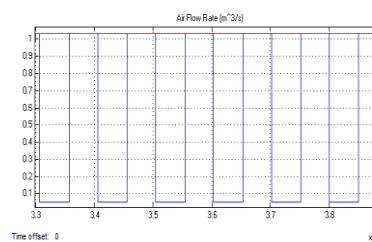

Blue: simulation results of DCV for CO_2 setpoint 800 ± 50 ppm
 Red: simulation results for the actual strategy used in building

The total amount of fresh air supplied into the classroom [m^3]

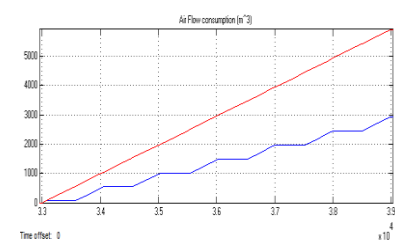

Blue: simulation results of DCV for CO_2 setpoint 800 ± 50 ppm
 Red: simulation results for the actual strategy used in building

Modelling ventilation

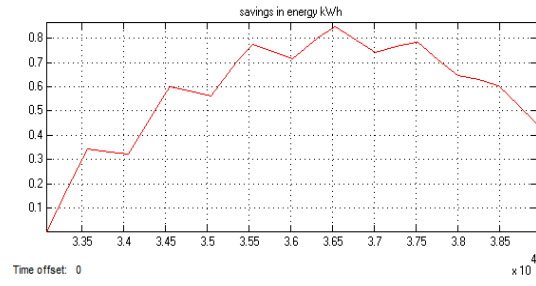

Savings in energy for heating/cooling by using DCV

Appendix 2

Weather inputs for MATLAB/SIMULINK model, which have been obtained from TUBO station: (outdoor temperature, outdoor relative humidity and intensity of solar radiation)+Weather outputs resulted from TRNSYS model (solar radiation incident on external walls NNW, SSE and ENE walls)

September 27/9/2012

TIME HOURS	Temperature C°	Relative humidity %	Solar radiation W/m ²	Solar radiation NNW W/m ²	Solar radiation SSE W/m ²	Solar radiation ENE W/m ²
0.00	18	96	0	0	0	0
1.00	17.7	96	0	0	0	0
2.00	17.7	96	0	0	0	0
3.00	17.8	93	0	0	0	0
4.00	18	92	0	0	0	0
5.00	18.2	88	8	2.02	61.7	109
6.00	18.5	86	41	19.2	23.2	24.8
7.00	18.6	84	19	11.4	11.4	11.4
8.00	17.7	82	64	38.4	38.4	38.4
9.00	16.2	79	71	42.6	42.6	42.6
10.00	16.1	80	94	56.4	56.4	56.4
11.00	16.6	76	210	126	126	126
12.00	17.3	63	255	123	124	123
13.00	18.1	57	191	91.4	92.0	91.4
14.00	17.5	60	152	72.3	72.7	72.3
15.00	16.8	62	43	25.8	25.8	25.8
16.00	16.7	63	45	21.3	21.0	21.0
17.00	16.3	67	0	0	0	0
18.00	15.8	74	0	0	0	0
19.00	15.3	78	0	0	0	0
20.00	14.8	84	0	0	0	0
21.00	14.5	84	0	0	0	0
22.00	14.3	84	0	0	0	0
23.00	14	86	0	0	0	0
24.00	13.6	86	0	0	0	0

October 22/10/2012

TIME HOURS	Temperature C°	Relative humidity %	Solar radiation W/m ²	Solar radiation	Solar radiation	Solar radiation
				NNW W/m ²	SSE W/m ²	ENE W/m ²
0.00	11.6	100	0	0	0	0
1.00	11.6	100	0	0	0	0
2.00	11.6	100	0	0	0	0
3.00	11.5	100	0	0	0	0
4.00	11.1	100	0	0	0	0
5.00	10.5	100	0	0	0	0
6.00	10.6	100	7	4.20	4.20	4.20
7.00	10.6	100	33	19.8	19.8	19.8
8.00	11	100	116	55.3	55.7	55.5
9.00	11.3	100	216	104	107	105
10.00	12.5	100	455	220	254	220
11.00	13.5	100	488	236	268	236
12.00	14.8	91	431	211	226	211
13.00	15.8	86	326	158	167	158
14.00	16.5	84	188	89.8	92.8	89.8
15.00	15.6	88	54	25.3	25.4	25.3
16.00	14.1	97	0	0	0	0
17.00	12.1	100	0	0	0	0
18.00	11.1	100	0	0	0	0
19.00	10.1	100	0	0	0	0
20.00	9.3	100	0	0	0	0
21.00	8.8	100	0	0	0	0
22.00	8.1	100	0	0	0	0
23.00	7.6	100	0	0	0	0
24.00	7	100	0	0	0	0

November 12/11/2012

TIME HOURS	Temperature C°	Relative humidity %	Solar radiation W/m ²	Solar radiation	Solar radiation	Solar radiation
				NNW W/m ²	SSE W/m ²	ENE W/m ²
0.00	7.5	100	0	0	0	0
1.00	7.4	100	0	0	0	0
2.00	7.4	100	0	0	0	0
3.00	7.6	100	0	0	0	0
4.00	8	100	0	0	0	0
5.00	7.8	100	0	0	0	0
6.00	7.6	100	0	0	0	0
7.00	7.6	100	27	12.7	14.6	13.8
8.00	7.8	100	49	29.4	29.4	29.4
9.00	8.1	100	57	34.2	34.2	34.2
10.00	9.1	100	217	105	108	105
11.00	9.6	100	101	60.6	60.6	60.6
12.00	9.6	100	85	51.0	51.0	51.0
13.00	10	100	55	33.0	33.0	33.0
14.00	10.1	100	70	42.0	42.0	42.0
15.00	10.1	100	5	3	3	3
16.00	10.1	100	0	0	0	0
17.00	9.1	100	0	0	0	0
18.00	9.1	100	0	0	0	0
19.00	8.8	100	0	0	0	0
20.00	8.6	100	0	0	0	0
21.00	8	100	0	0	0	0
22.00	7.9	100	0	0	0	0
23.00	8.1	100	0	0	0	0
24.00	7.4	100	0	0	0	0

December 7/12/2012

TIME HOURS	Temperature C°	Relative humidity %	Solar radiation W/m ²	Solar radiation	Solar radiation	Solar radiation
				NNW W/m ²	SSE W/m ²	ENE W/m ²
0.00	-4.9	85	0	0	0	0
1.00	-5.5	87	0	0	0	0
2.00	-6.3	91	0	0	0	0
3.00	-6.8	93	0	0	0	0
4.00	-7.5	98	0	0	0	0
5.00	-8.6	100	0	0	0	0
6.00	-8.6	100	0	0	0	0
7.00	-8.8	100	12	5.74	6.41	6.07
8.00	-8.1	100	129	61.3	217	114
9.00	-6	97	208	100	129	104
10.00	-5.1	93	280	136	164	136
11.00	-4.6	90	295	144	158	144
12.00	-3.8	89	260	127	135	127
13.00	-3.2	86	172	83.0	85.8	83.0
14.00	-4	86	64	38.4	38.4	38.4
15.00	-4.5	90	0	0	0	0
16.00	-5	92	0	0	0	0
17.00	-5.3	93	0	0	0	0
18.00	-6.3	96	0	0	0	0
19.00	-7.5	100	0	0	0	0
20.00	-7.4	100	0	0	0	0
21.00	-7.4	100	0	0	0	0
22.00	-6.9	100	0	0	0	0
23.00	-6.5	100	0	0	0	0
24.00	-6	100	0	0	0	0

January 25/1/2013

TIME HOURS	Temperature C°	Relative humidity %	Solar radiation W/m ²	Solar radiation	Solar radiation	Solar radiation
				NNW W/m ²	SSE W/m ²	ENE W/m ²
0.00	-2.8	99	0	0	0	0
1.00	-3.4	96	0	0	0	0
2.00	-3.8	95	0	0	0	0
3.00	-4.1	95	0	0	0	0
4.00	-4.5	94	0	0	0	0
5.00	-5	94	0	0	0	0
6.00	-5.5	93	0	0	0	0
7.00	-5.6	93	9	5.40	5.40	5.40
8.00	-5.5	90	37	22.2	22.2	22.2
9.00	-5.5	89	60	36.0	36.0	36.0
10.00	-5.3	86	96	57.6	57.6	57.6
11.00	-5	84	137	82.2	82.2	82.2
12.00	-4.5	83	147	88.2	88.2	88.2
13.00	-4.5	83	123	73.8	73.8	73.8
14.00	-4.5	84	118	70.8	70.8	70.8
15.00	-4.8	86	31	18.6	18.6	18.6
16.00	-4.9	85	0	0	0	0
17.00	-5	85	0	0	0	0
18.00	-5.3	85	0	0	0	0
19.00	-5.5	85	0	0	0	0
20.00	-5.9	86	0	0	0	0
21.00	-5.9	87	0	0	0	0
22.00	-5.8	86	0	0	0	0
23.00	-5.8	87	0	0	0	0
24.00	-6	88	0	0	0	0

February 21/2/2013

TIME HOURS	Temperature C°	Relative humidity %	Solar radiation W/m ²	Solar radiation	Solar radiation	Solar radiation
				NNW W/m ²	SSE W/m ²	ENE W/m ²
0.00	-4.4	100	0	0	0	0
1.00	-4.8	100	0	0	0	0
2.00	-5	100	0	0	0	0
3.00	-5.6	100	0	0	0	0
4.00	-5.4	100	0	0	0	0
5.00	-5	100	0	0	0	0
6.00	-4.5	100	6	0	0	0
7.00	-4.5	96	74	36.5	94.1	86.9
8.00	-3.5	88	341	150	354	265
9.00	-3.2	81	439	203	314	235
10.00	-2.5	71	570	262	388	266
11.00	-1.4	61	277	135	136	135
12.00	-1.1	66	146	87.6	87.6	87.6
13.00	-1.4	58	161	96.6	96.6	96.6
14.00	-1.7	63	117	70.2	70.2	70.2
15.00	-1.8	60	57	34.2	34.2	34.2
16.00	-2.4	66	9	5.40	5.40	5.40
17.00	-2.8	70	0	0	0	0
18.00	-2.9	73	0	0	0	0
19.00	-3	79	0	0	0	0
20.00	-3.8	86	0	0	0	0
21.00	-4.6	90	0	0	0	0
22.00	-5.5	88	0	0	0	0
23.00	-5.4	84	0	0	0	0
24.00	-6	86	0	0	0	0

March 8/3/2013

TIME HOURS	Temperature C°	Relative humidity %	Solar radiation W/m ²	Solar radiation	Solar radiation	Solar radiation
				NNW W/m ²	SSE W/m ²	ENE W/m ²
0.00	8.1	100	0	0	0	0
1.00	7.9	100	0	0	0	0
2.00	8	100	0	0	0	0
3.00	7.4	100	0	0	0	0
4.00	7.6	100	0	0	0	0
5.00	7.5	100	0	0	0	0
6.00	7.8	100	24	12.3	22.0	25.1
7.00	8.6	100	55	33.0	33.0	33.0
8.00	9.3	100	56	33.6	33.6	33.6
9.00	9.8	100	71	42.6	42.6	42.6
10.00	10.1	100	95	57.0	57.0	57.0
11.00	10.8	98	239	143	143	143
12.00	11.1	96	111	66.6	66.6	66.6
13.00	11	99	57	34.2	34.2	34.2
14.00	10.8	99	43	25.8	25.8	25.8
15.00	10.5	99	43	25.8	25.8	25.8
16.00	9.8	100	9	5.40	5.40	5.40
17.00	8.8	100	0	0	0	0
18.00	8.1	100	0	0	0	0
19.00	7.5	100	0	0	0	0
20.00	7	100	0	0	0	0
21.00	7	100	0	0	0	0
22.00	6.5	100	0	0	0	0
23.00	5.8	100	0	0	0	0
24.00	5.1	100	0	0	0	0

April 23/4/2013

TIME HOURS	Temperature C°	Relative humidity %	Solar radiation W/m ²	Solar radiation	Solar radiation	Solar radiation
				NNW W/m ²	SSE W/m ²	ENE W/m ²
0.00	11.1	93	0	0	0	0
1.00	10	100	0	0	0	0
2.00	9.5	100	0	0	0	0
3.00	8.8	100	0	0	0	0
4.00	8.1	100	8	3.41	10.5	56.0
5.00	8.6	100	128	59.2	110	273
6.00	11.5	93	254	122	138	157
7.00	14.3	78	448	212	249	263
8.00	16.2	68	600	286	330	324
9.00	18	62	736	352	402	376
10.00	19.5	60	824	395	445	401
11.00	21	56	724	359	373	359
12.00	21.2	54	471	231	235	231
13.00	20.2	56	357	174	175	174
14.00	20.6	53	691	331	339	331
15.00	20.7	48	296	143	142	142
16.00	20.3	50	206	101	97.9	97.9
17.00	19.8	49	89	45.0	41.7	41.7
18.00	18.5	53	0	0	0	0
19.00	17	59	0	0	0	0
20.00	15.5	66	0	0	0	0
21.00	14.6	69	0	0	0	0
22.00	13.6	72	0	0	0	0
23.00	12.6	78	0	0	0	0
24.00	11	91	0	0	0	0

May 7/5/2013

TIME HOURS	Temperature C°	Relative humidity %	Solar radiation W/m ²	Solar	Solar	Solar
				radiation NNW W/m ²	radiation SSE W/m ²	radiation ENE W/m ²
0.00	15.1	100	0	0	0	0
1.00	15.3	100	0	0	0	0
2.00	14.6	100	0	0	0	0
3.00	15.1	100	0	0	0	0
4.00	15.6	100	10	4.66	4.70	5.44
5.00	16.2	100	83	39.3	40.7	46.6
6.00	17.2	100	246	119	125	134
7.00	17.5	100	81	48.6	48.6	48.6
8.00	17.3	100	153	91.8	91.8	91.8
9.00	19.1	88	484	238	243	241
10.00	19.8	82	583	289	295	290
11.00	21	78	404	199	199	199
12.00	20.5	79	126	75.6	75.6	75.6
13.00	18.8	99	142	85.2	85.2	85.2
14.00	17.7	100	104	62.4	62.4	62.4
15.00	19	100	186	112	112	112
16.00	18	100	119	71.4	71.4	71.4
17.00	18.2	100	64	38.4	38.4	38.4
18.00	18.2	100	0	0	0	0
19.00	18	100	0	0	0	0
20.00	16.6	100	0	0	0	0
21.00	16.5	100	0	0	0	0
22.00	16.6	100	0	0	0	0
23.00	16.2	100	0	0	0	0
24.00	15.6	100	0	0	0	0

June 20/6/2013

TIME HOURS	Temperature C°	Relative humidity %	Solar radiation W/m ²	Solar	Solar	Solar
				radiation NNW W/m ²	radiation SSE W/m ²	radiation ENE W/m ²
0.00	25.3	83	0	0	0	0
1.00	24.7	89	0	0	0	0
2.00	24.1	98	0	0	0	0
3.00	23.8	99	3	2.97	1.48	9.16
4.00	24.5	92	93	58.5	43.6	204
5.00	25.5	84	252	118	133	283
6.00	27.1	77	421	197	219	276
7.00	28.2	71	595	279	315	351
8.00	28.7	67	738	349	391	401
9.00	30	65	862	410	456	444
10.00	31.1	62	915	440	479	451
11.00	32.2	59	1068	503	558	503
12.00	33.9	53	867	424	441	424
13.00	33.7	48	856	415	426	415
14.00	33.7	46	718	350	351	350
15.00	34.9	46	554	275	268	268
16.00	33.7	47	386	195	185	185
17.00	32.5	51	204	106	96.3	96.3
18.00	31.1	56	48	24.8	22.2	22.2
19.00	29.3	62	0	0	0	0
20.00	28.2	67	0	0	0	0
21.00	27.2	74	0	0	0	0
22.00	26.7	81	0	0	0	0
23.00	26.2	87	0	0	0	0
24.00	25.7	88	0	0	0	0

July 19/7/2013

TIME HOURS	Temperature C°	Relative humidity %	Solar radiation W/m ²	Solar radiation NNW W/m ²	Solar radiation SSE W/m ²	Solar radiation ENE W/m ²
0.00	18.8	82	0	0	0	0
1.00	18.2	85	0	0	0	0
2.00	17.3	95	0	0	0	0
3.00	17.3	95	0	0	0	0
4.00	16.8	100	58	33.1	27.7	130
5.00	18	94	198	92.3	101	171
6.00	19.8	85	367	172	194	242
7.00	22.2	74	544	256	291	322
8.00	25.2	61	687	326	367	375
9.00	27	50	891	416	484	463
10.00	27.6	44	713	352	367	356
11.00	27.7	46	997	473	524	473
12.00	28.3	41	952	456	489	456
13.00	29.8	39	344	167	168	167
14.00	29.7	38	734	356	358	356
15.00	30	33	560	277	271	271
16.00	29.3	35	378	190	181	181
17.00	28.7	36	206	107	97.2	97.2
18.00	27.5	43	52	27.6	24.1	24.1
19.00	25.5	46	0	0	0	0
20.00	23.6	53	0	0	0	0
21.00	21.8	61	0	0	0	0
22.00	20.5	68	0	0	0	0
23.00	19.7	73	0	0	0	0
24.00	18.6	81	0	0	0	0

August 8/8/2013

TIME HOURS	Temperature C°	Relative humidity %	Solar radiation W/m ²	Solar radiation NNW W/m ²	Solar radiation SSE W/m ²	Solar radiation ENE W/m ²
0.00	25.8	54	0	0	0	0
1.00	26.2	52	0	0	0	0
2.00	26.3	48	0	0	0	0
3.00	25.7	49	0	0	0	0
4.00	25.2	51	8	4.16	4.39	9.07
5.00	26.1	48	147	68.2	99.3	254
6.00	27.5	44	317	147	210	316
7.00	28.7	44	492	229	275	304
8.00	29.8	43	646	303	357	358
9.00	31.2	41	782	368	428	404
10.00	33.9	36	829	396	444	406
11.00	33.7	34	877	420	464	420
12.00	35.5	31	818	396	422	396
13.00	36.5	27	554	269	276	269
14.00	37.7	25	628	304	308	304
15.00	37.7	23	383	185	183	183
16.00	38.9	22	289	144	136	136
17.00	36.9	23	114	59.0	52.9	52.9
18.00	34.9	30	16	89.6	72.9	72.9
19.00	33.9	34	0	0	0	0
20.00	29.2	48	0	0	0	0
21.00	27.3	60	0	0	0	0
22.00	27.6	58	0	0	0	0
23.00	25.5	68	0	0	0	0
24.00	25	70	0	0	0	0

Appendix 3

Basic interfaces and sub-models of the SIMULINK model

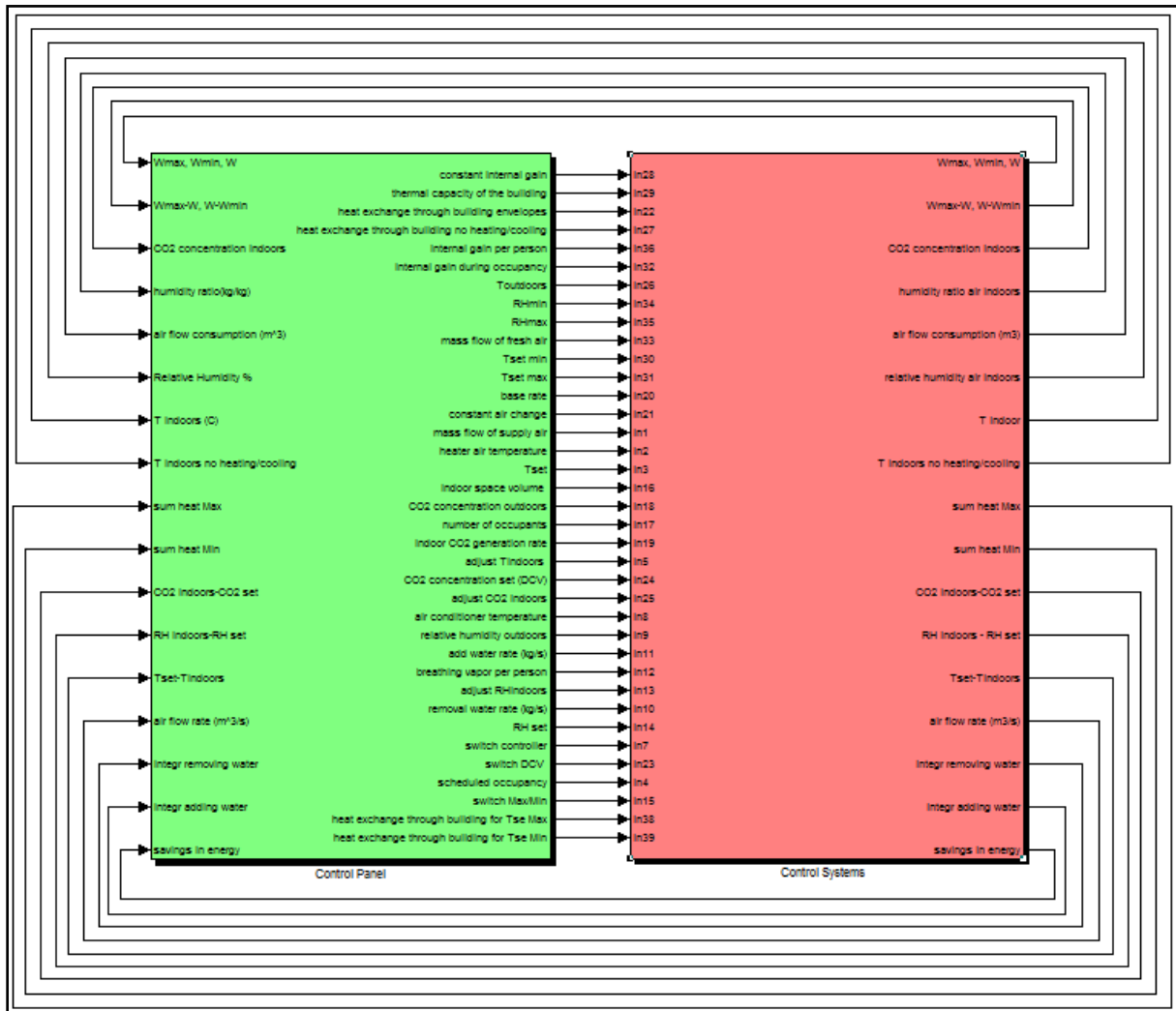

Basic interface (Control Panel + Control Systems)

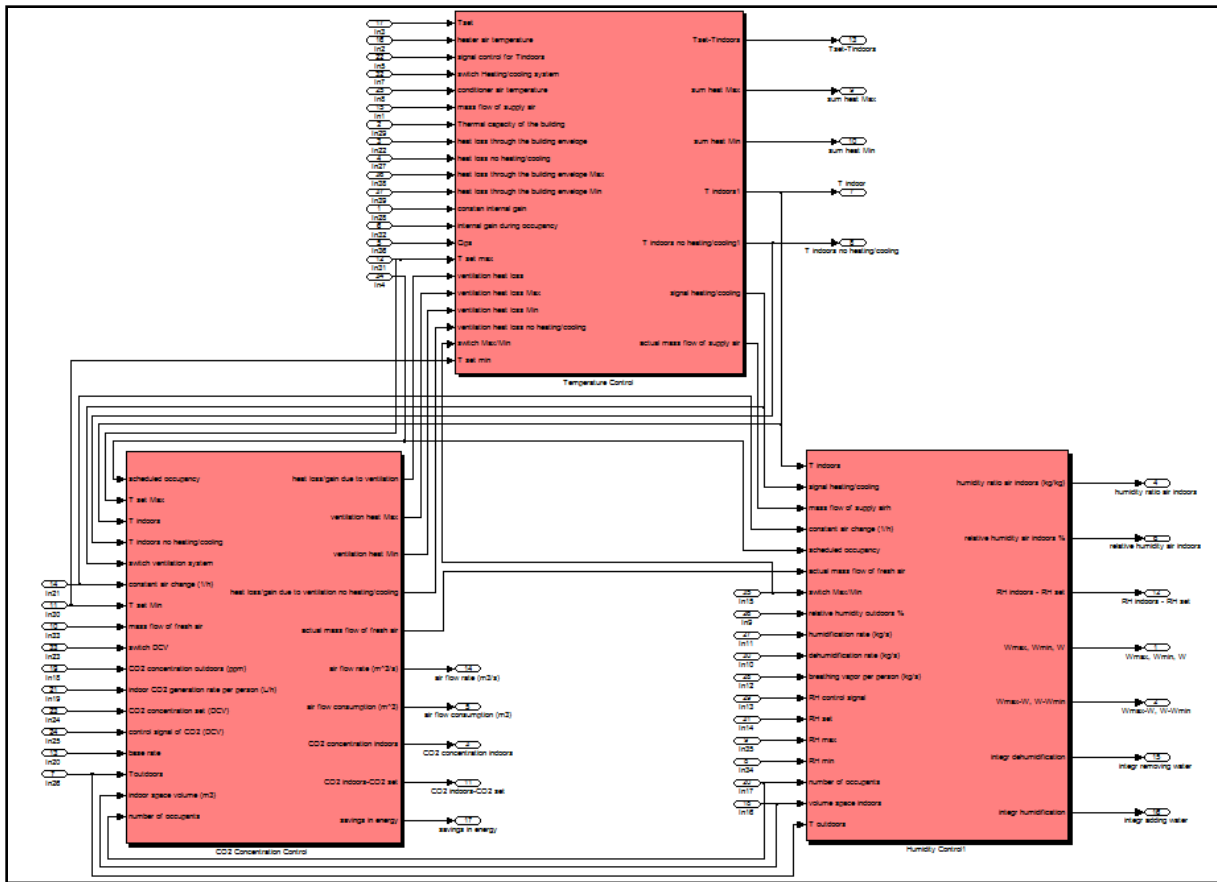

Control Systems (Temperature Model + CO₂ Concentration Model + Relative Humidity Model)

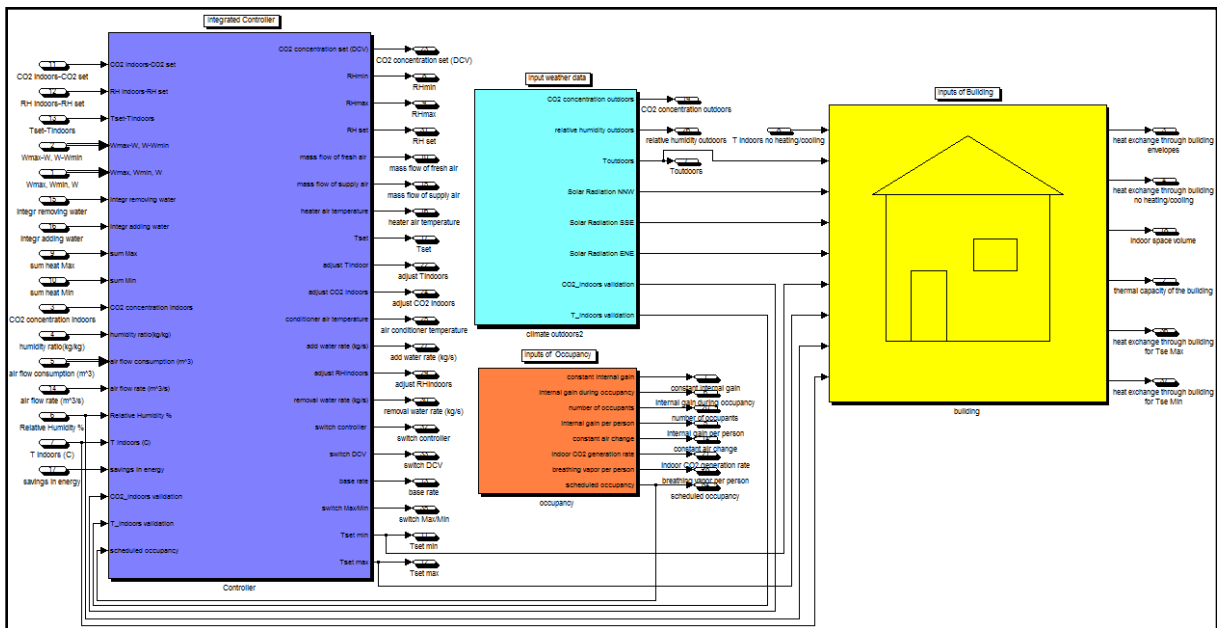

Control Panel interface (Integrated Controller+ Inputs of Weather Data+ Inputs of Occupancy+ Building)

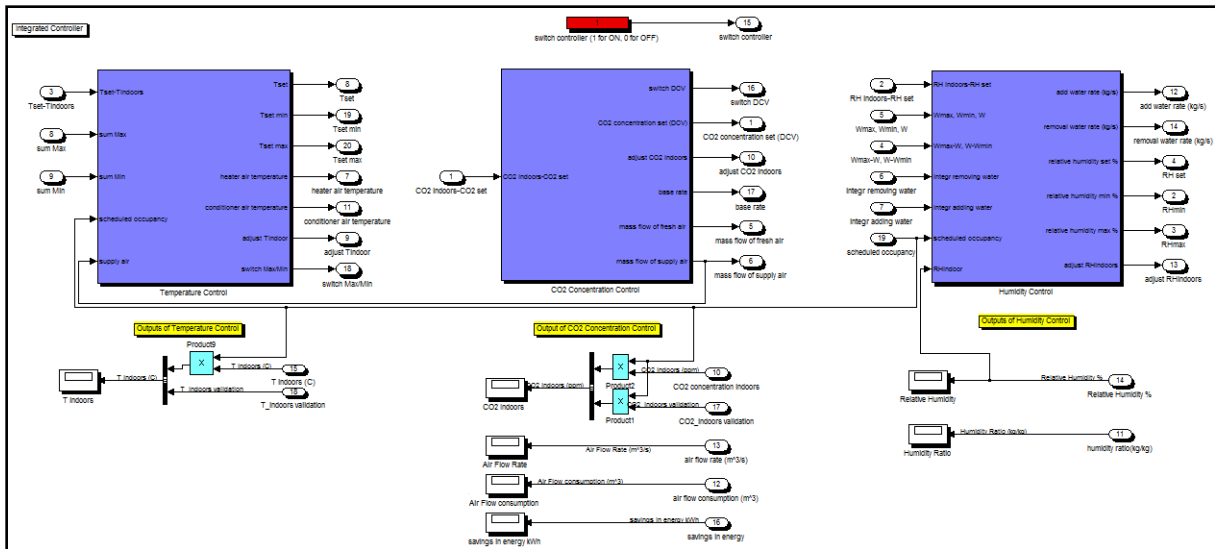

Integrated Controller interface (Temperature Control+ CO₂ Concentration Control+ Relative Humidity Control)

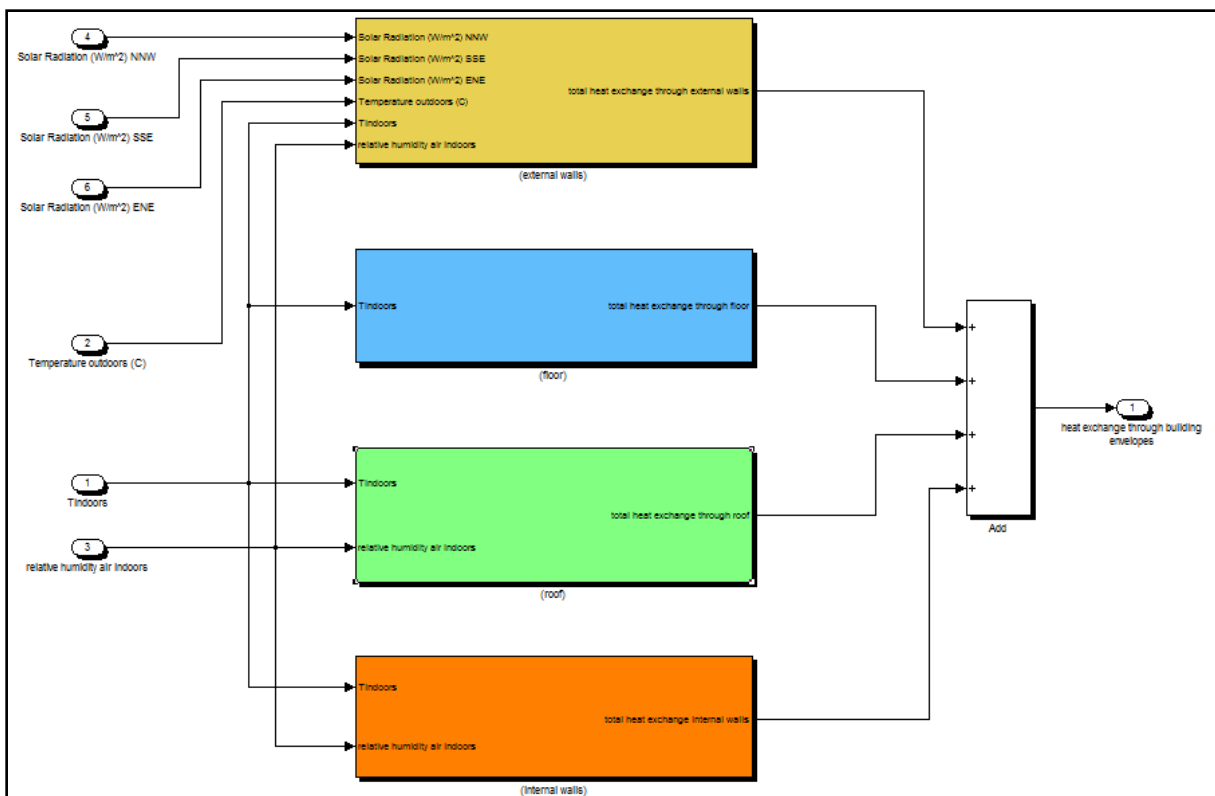

Building interface (external walls + floor + roof + internal walls)

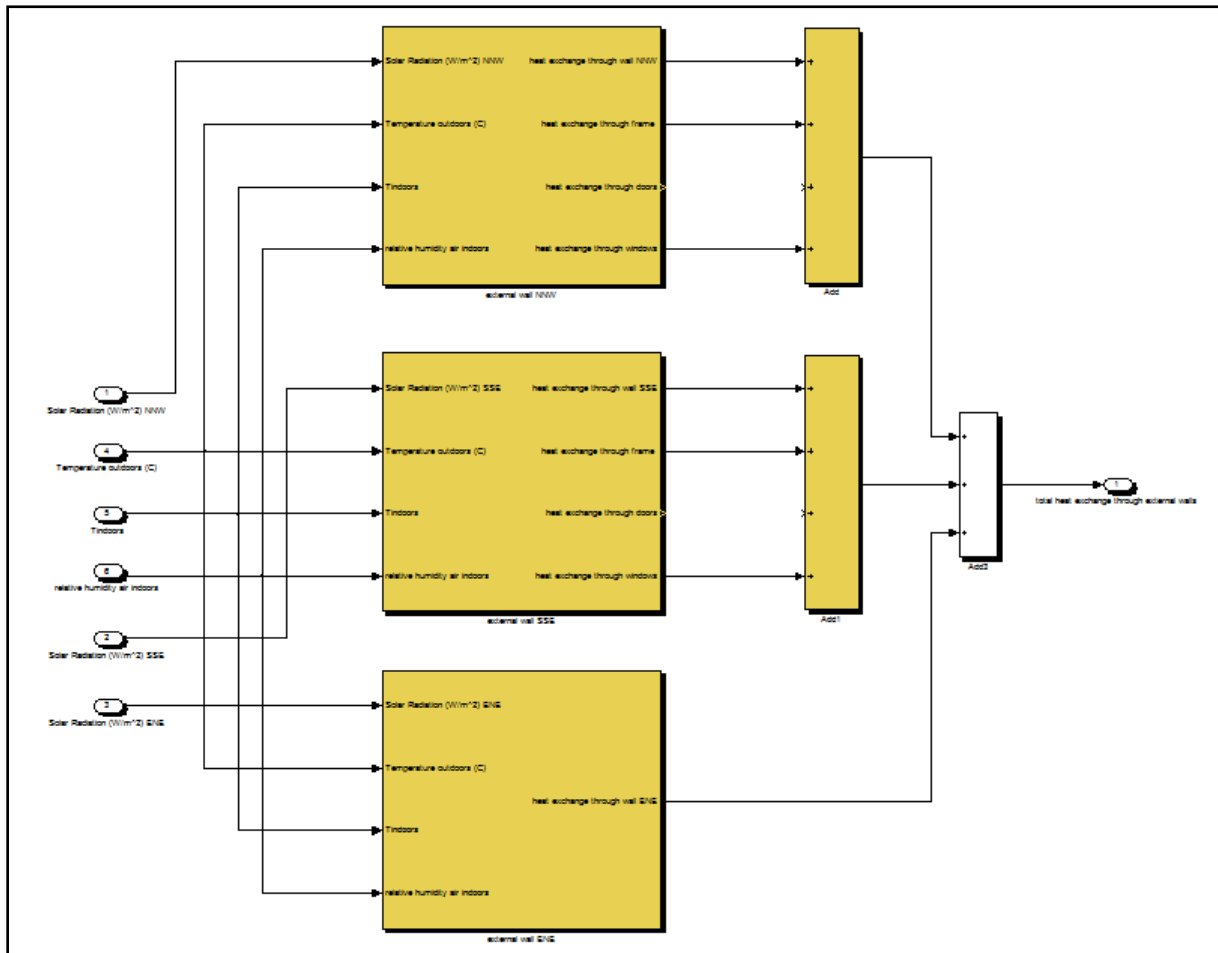

External walls interface (external wall NNW + external wall SSE + external wall ENE)

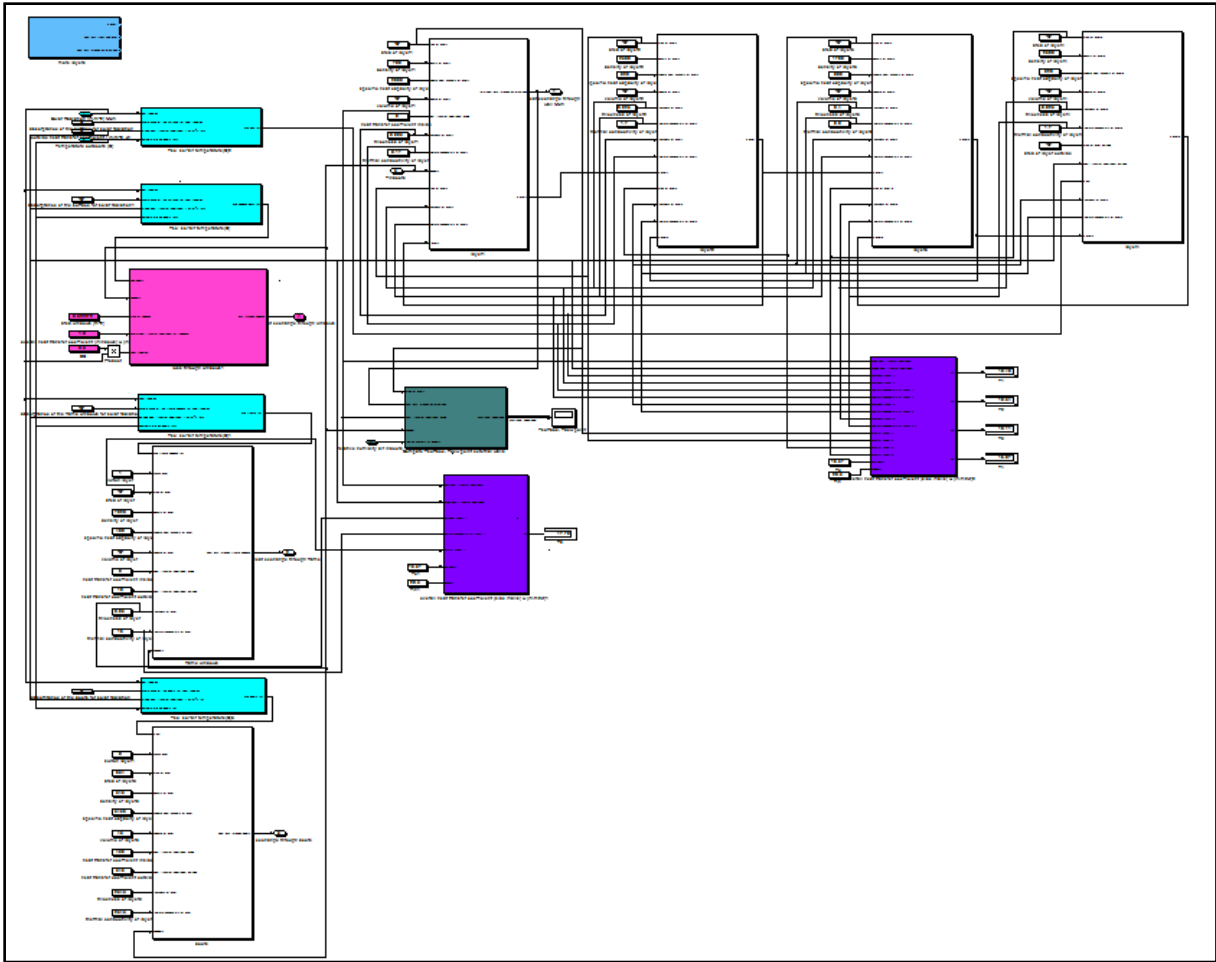

External wall NNW interface (wall layers + window + frame + sub-models of sol-air temperature + sub-model of detecting condensation on the wall + sub-models for initial temperatures of layers)