

VYSOKÉ UČENÍ TECHNICKÉ V BRNĚ

Fakulta elektrotechniky
a komunikačních technologií

BAKALÁŘSKÁ PRÁCE



VYSOKÉ UČENÍ TECHNICKÉ V BRNĚ

BRNO UNIVERSITY OF TECHNOLOGY

FAKULTA ELEKTROTECHNIKY A KOMUNIKAČNÍCH TECHNOLOGIÍ

FACULTY OF ELECTRICAL ENGINEERING AND COMMUNICATION

ÚSTAV RADIOELEKTRONIKY

DEPARTMENT OF RADIO ELECTRONICS

KOEXISTENCE BEZDRÁTOVÝCH SYSTÉMŮ LORA A BLUETOOTH

COEXISTENCE OF WIRELESS SYSTEMS LORA AND BLUETOOTH

BAKALÁŘSKÁ PRÁCE

BACHELOR'S THESIS

AUTOR PRÁCE

AUTHOR

Filip Paul

VEDOUCÍ PRÁCE

SUPERVISOR

doc. Ing. Ladislav Polák, Ph.D.

BRNO 2021



Bakalářská práce

bakalářský studijní program **Elektronika a komunikační technologie**

Ústav radioelektroniky

Student: Filip Paul

ID: 211538

Ročník: 3

Akademický rok: 2020/21

NÁZEV TÉMATU:

Koexistence bezdrátových systémů LoRa a Bluetooth

POKYNY PRO VYPRACOVÁNÍ:

V teoretické části práce se seznámte s fyzickou (PHY) vrstvou bezdrátových komunikačních systémů LoRa a Bluetooth. Definujte radiofrekvenční (RF) pásmo, ve kterém tyto systémy mohou koexistovat. Navrhněte měřicí testbed, využívající vývojový kit SK-iM282A, pro měření různých koexistenčních scénářů a metodiku pro vyhodnocení měření.

V experimentální části práce proveďte laboratorní měření definovaných koexistenčních scénářů. V rámci měření uvažujte různé systémové parametry. Zvolte vhodnou metodiku pro vyhodnocení odolnosti systému LoRa vůči interferenci. Získané výsledky přehledně vyhodnoťte a v rámci možností porovnejte s teoretickými předpoklady a dostupnou literaturou. Navrhněte laboratorní úlohu pro měření koexistence systémů LoRa a Bluetooth a připravte vzorové vypracování navržené úlohy.

DOPORUČENÁ LITERATURA:

[1] ORFANIDIS, Charalamos, and et al. Investigating interference between LoRa and IEEE 802.15.4g networks. In: 2017 IEEE 13th International Conference on Wireless and Mobile Computing, Networking and Communications (WiMob) [online]. IEEE, 2017, 2017, s. 1-8 [cit. 2020-04-22]. DOI: 10.1109/WiMOB.2017.8115772. ISBN 978-1-5386-3839-2.

[2] Semtech. SX1280 Long Range, Low Power 2.4 GHz Transceiver. Application Note: Bluetooth® Immunity of LoRa® at 2.4 GHz. Application Note, 21 pages. April 2018. Dostupný z WWW: <https://lora-developers.semtech.com/library/product-documents/>

Termín zadání: 8.2.2021

Termín odevzdání: 27.5.2021

Vedoucí práce: doc. Ing. Ladislav Polák, Ph.D.

prof. Ing. Tomáš Kratochvíl, Ph.D.
předseda rady studijního programu

UPOZORNĚNÍ:

Autor bakalářské práce nesmí při vytváření bakalářské práce porušit autorská práva třetích osob, zejména nesmí zasahovat nedovoleným způsobem do cizích autorských práv osobnostních a musí si být plně vědom následků porušení ustanovení § 11 a následujících autorského zákona č. 121/2000 Sb., včetně možných trestněprávních důsledků vyplývajících z ustanovení části druhé, hlavy VI. díl 4 Trestního zákoníku č.40/2009 Sb.

Abstract

This bachelor thesis focuses on the coexistence between LoRa and Bluetooth technologies in the unlicensed 2.4 GHz ISM band. The thesis consists from two main parts, namely theoretical and experimental. The theoretical part describes the physical layer and defines coexistence scenarios between both systems. The experimental part is intended to the design and realization of measuring testbed to measure different coexistence scenarios, which may occur between LoRa and Bluetooth systems, in the 2.4 GHz ISM band, including the processing of measured data. Finally, based on the results obtained from measurements, a laboratory task is proposed for educational purposes for course mobile communication taught at BUT university.

Keywords

LoRa, Bluetooth, LPWAN, WPAN, coexistence of wireless systems, interference, ISM, 2.4 GHz, PER, RF measurement, protection ratio.

Abstrakt

Bakalářská práce je zaměřena na koexistenci LoRa a Bluetooth technologií v bezlicenčním 2.4 GHz ISM pásmu. Práce se skládá ze dvou hlavních částí, jmenovitě teoretické a experimentální. Ve své teoretické části se věnuje popisu fyzické vrstvy obou systémů a definuje koexistenční scénáře, které mohou mezi oběma systémy nastat. V experimentální části je navržen a zrealizován měřicí testbed pro měření koexistenčních scénářů, které mohou nastat mezi LoRa a Bluetooth systémy v 2.4 GHz ISM pásmu včetně následného zpracování naměřených dat. Na závěr je navrhována laboratorní úloha a založená na experimentální části diplomové práce, která slouží pro edukativní účely pro kurz mobilních komunikací vyučovaný na univerzitě VUT.

Klíčová slova

LoRa, Bluetooth, LPWAN, WPAN, koexistence bezdrátových systémů, interference, ISM, 2.4 GHz, PER.

Rozšířený abstrakt

V současné době můžeme sledovat rostoucí trend Low Power Wide Area Network (LPWAN) sítí. V roce 2018 bylo aktivních 223 milionů zařízení operujících v této síti a do konce roku 2023 se očekává nárůst na 1.9 miliard aktivních zařízení [1, 2]. LPWAN sítě se vyznačují nízkými nároky na energetickou spotřebu (až desítky let na jedno nabití baterie), velkým dosahem (desítky kilometrů) a nižšími přenosovými rychlostmi (jednotky až stovky Kb/s). Zařízení operující v LPWAN síti je tak svými vlastnostmi vhodné pro Internet-Of-Things (IoT) scénáře. IoT umožňuje uživatelům vzdáleně automatizovat reálné procesy jako automatizace domácností, odečítání dat z různých senzorů, monitorování životních funkcí, zabezpečení objektů atd.[3, 4].

Long Range (LoRa) je jedním z členů z rychle rostoucí LPWAN sítě. Původně byla navržena pro sub-GHz pásmo. V současnosti však umožňuje využívat i bezlicenční 2.4 GHz Industrial Scientific and Medicin (ISM) pásmo bez omezujících požadavků na duty cycle. Toto pásmo je hojně využíváno technologiemi jako Bluetooth a WiFi. V porovnání s LoRa má Bluetooth vyšší přenosové rychlosti, na druhou stranu vyšší spotřebu a dosah v jednotkách až desítkách metrů [5, 6, 7].

Jak bylo zmíněno výše, LoRa a Bluetooth mohou využívat stejného rádiového spektra, což může způsobit rušení a znemožnit tak provoz těchto technologií ve společném RF pásmu. Z tohoto důvodu je nutné se věnovat koexistenčním scénářům, které mohou mezi jednotlivými systémy nastat. Tato práce se zabývá pouze koexistencí mezi technologiemi Bluetooth a LoRa v 2.4 GHz ISM pásmu. Za účelem měření koexistenčních scénářů, které mohou nastat mezi LoRa a Bluetooth technologiemi byla navržena metodika měření a realizován měřicí testbed. Výsledky měření jsou následně komentovány v experimentální části bakalářské práce.

DECLARATION

I declare that I have written the semestral project titled “Coexistence of wireless systems LoRa and Blueooth” independently, under the guidance of the advisor and using exclusively the technical references and other sources of information cited in the project and listed in the comprehensive bibliography at the end of the project.

As the author I furthermore declare that, with respect to the creation of this semestral project, I have not infringed any copyright or violated anyone’s personal and/or ownership rights. In this context, I am fully aware of the consequences of breaking Regulation § 11 of the Copyright Act No. 121/2000 Coll. of the Czech Republic, as amended, and of any breach of rights related to intellectual property or introduced within amendments to relevant Acts such as the Intellectual Property Act or the Criminal Code, Act No. 40/2009 Coll., Section 2, Head VI, Part 4.

Brno

.....

author’s signature

Contents

Introduction	10
1 LoRa Technology	11
1.1 LoRa Introduction	11
1.2 LoRaWAN	11
1.3 LoRa PHY layer	13
1.3.1 LoRa Modulation	13
1.3.2 LoRa Bandwidth	14
1.3.3 Spreading factor	15
1.3.4 Coding Rate	15
1.4 Frequency bands and channels	16
1.5 LoRa frame	16
2 Bluetooth	18
2.1 Bluetooth Introduction	18
2.2 Piconet and Scatternet	18
2.3 Bluetooth PHY	19
2.3.1 Bluetooth Modulation	19
2.3.2 Modulation parameters	24
2.4 Frequency bands and channels	24
3 Coexistence Scenarios	25
4 Measurement methodology	27
4.1 Measured parameters	27
4.2 Measurement testbed	27
4.3 Hardware and Software description	30
4.3.1 LoRa SK-IM282A module and WiMOD LR studio	30
4.3.2 R&S SMU200A	32
4.3.3 R&S FSQ	32
5 Experimental measurements	33
5.1 LoRa: BW = 200 kHz	34
5.2 LoRa: BW = 400 kHz	36
5.3 LoRa: BW = 800 kHz	38
5.4 LoRa: BW = 1600 kHz	39
5.5 Summary of the results	41
5.6 Comparison with related works	43

Conclusion	44
Bibliography	45
List of symbols, quantities and abbreviations	48

List of Figures

1	Market situation of mobile networks (taken from [1])	10
1.1	LPWAN classification by power vs distance (taken from [5])	11
1.2	Structure of LoRa systems (taken from [8])	12
1.3	LoRaWAN (taken from [7])	12
1.4	Upchirps (blue), Downchirps (red) and their frequency in time domain	13
1.5	Message modulated in frequency jumps and FFT of signal	14
1.6	LoRa PHY layer block diagram, (taken from [12])	14
1.7	Relationship between SF and symbol rate	15
1.8	Lora Frame	16
2.1	Piconet and Scatternet	18
2.2	BFSK modulation: time domain signal and its spectrum	20
2.3	CPFSK modulation time domain and spectrum	21
2.4	Gaussian filter: Transfer function, impulse response and filtered input message	22
2.5	GFSK modulation time domain and spectrum	23
2.6	FHSS modulation time domain, spectrum and frequency pattern	23
3.1	Coexistence scenarios	25
3.2	Possible coexistence of LoRa and Bluetooth systems in the 2.4 GHz ISM band	26
4.1	Block diagram and photo of measurement testbed	28
4.2	LoRa SK-IM282A module	30
4.3	WiMOD LR Studio GUI	31
5.1	LoRa BW200 C/I for various SF	35
5.2	Spectra of Bluetooth and LoRa signals at $\Delta f = 0$ and Δf_{max}	35
5.3	LoRa BW400 C/I for various SF	36
5.4	Comparison of PR for LoRa BW200 and 400 for SF = 5 (red) and 12 (blue)	37
5.5	Spectra of Bluetooth and LoRa signals at $\Delta f = 0$ and Δf_{max}	37
5.6	LoRa BW800 C/I for various SF	38
5.7	Spectra of Bluetooth and LoRa signals at $\Delta f = 0$ and Δf_{max}	39
5.8	LoRa BW1600 C/I for various SF	40
5.9	Spectra of Bluetooth and LoRa signals at $\Delta f = 0$ and Δf_{max}	40
5.10	Comparison of all BWs for SF = 5 and SF = 12	42

List of Tables

1.1	LoRa, available Bandwidth and spreading factor settings according to RF band	16
4.1	Measured combinations of LoRa PHY	27
4.2	Available parameters in WiMOD LR Studio	31
5.1	Bluetooth PHY parameters	33
5.2	Parameters of LoRa and Bluetooth PHY	34
5.3	Parameters of LoRa and Bluetooth PHY	38
5.4	Parameters of LoRa and Bluetooth PHY	39
5.5	Comparison of the SFs effect on PR for individual LoRa BWs	41

Introduction

Nowadays, interest for Low Power Area Network (LPWAN) is rapidly increasing. In 2018, 223 million active devices worked in LPWAN, and by 2023 the number should increase to 1.9 billion (Fig. 1)[1, 2]. LPWAN is characterized by low power consumption of end devices (up to decades per battery charge), long range (tens of kilometers), and low data rates (units up to hundreds of Kb/s). Devices operating in LPWAN are suitable for the Internet Of Things (IoT) scenarios. IoT allows users to remotely automate real-life processes, such as home automatization, collecting data from sensors, medicine, and security [3, 4, 5].

Long Range (LoRa) is a member of the LPWAN family. It was initially designed for the sub-GHz band. Nowadays, LoRa also supports the 2.4 GHz Industrial, Scientific and Medical (ISM) bands [6]. This Radio Frequency (RF) band is widely used by many technologies, such as Bluetooth, Wi-Fi and LoRa. Bluetooth is a member of the Personal Area Network (PAN). In comparison with LoRa, Bluetooth has higher transmission speed, but on the other hand, consumes more power and can send data over significantly shorter distances. Because LoRa and Bluetooth can share the same RF band, problems with coexistence may occur. It can lead to interferences between these systems. Therefore it is essential to explore the coexistence scenarios of these technologies. In this thesis, only the coexistence between Bluetooth and LoRa in the 2.4 GHz ISM band is discussed. In order to measure the coexistence scenarios that may occur between LoRa and Bluetooth technologies, a measurement methodology and measuring testbed were implemented. The measurement results are commented in the experimental part of the thesis.

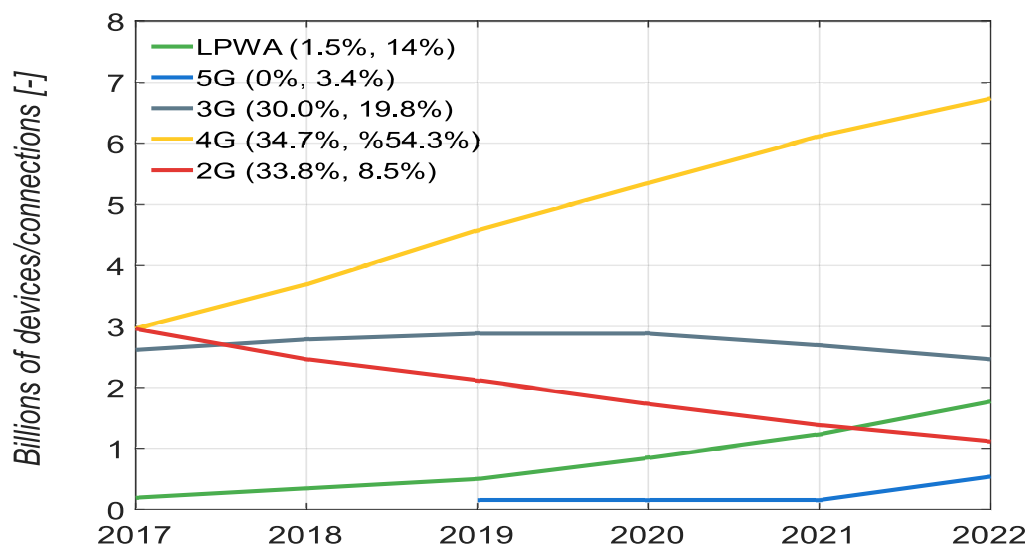

Fig. 1: Market situation of mobile networks (taken from [1])

1 LoRa Technology

1.1 LoRa Introduction

LoRa is a member of the LPWAN family (see fig. 1.1). This network is intended for the transmission of small data packets (0.3 kbps up to 50 kbps) over long distances (tens of kilometers) at low power (units of μA). Thanks to its lower power consumption, this network is suitable for battery-powered IoT devices [4].

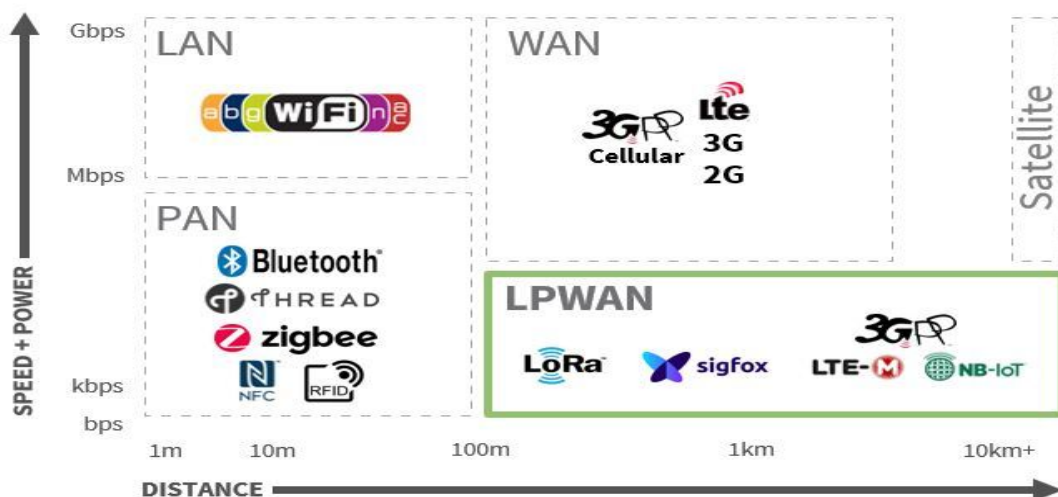

Fig. 1.1: LPWAN classification by power vs distance (taken from [5])

1.2 LoRaWAN

The LoRaWAN protocol defines network architecture for devices that use LoRa to communicate. LoRa is then just a designation of the PHY (see fig. 1.2). This network uses a star topology (see fig. 1.3). LoRaWAN is composed of end-nodes that communicate with the Gateway. A single end-node can send data to the multiple Gateways at the same time. From the Gateway, data are sent (via 3G/Ethernet/Backhaul) to the network server, which provides all the necessary work, such as security acts, network management, and acknowledgment. The last parts of LoRaWAN are application servers that usually represent personal laptops or other devices capable of internet connection, where the data is processed. In all steps, the transmission can be done in both directions [7].

The end node devices are divided into three classes, namely: A, B, and C. Class A is powered by batteries and opens two small downlink windows only after each uplink. In other words, the device can download data only after sending some

data. After data transfer, the device activates a sleep mode, in which LoRa can achieve low power consumption (units of μA).

Class B works in the same way as Class A, but also, it opens a downlink window in scheduled time intervals. Class C has a downlink window open all the time. In other words, the device is listening continuously for a signal. By doing that, it consumes more power. In this thesis, only Class A devices will be discussed [4, 7].

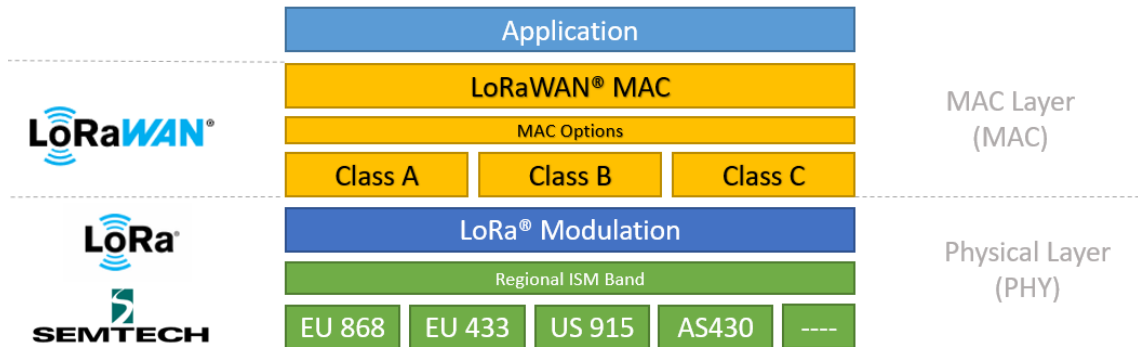

Fig. 1.2: Structure of LoRa systems (taken from [8])

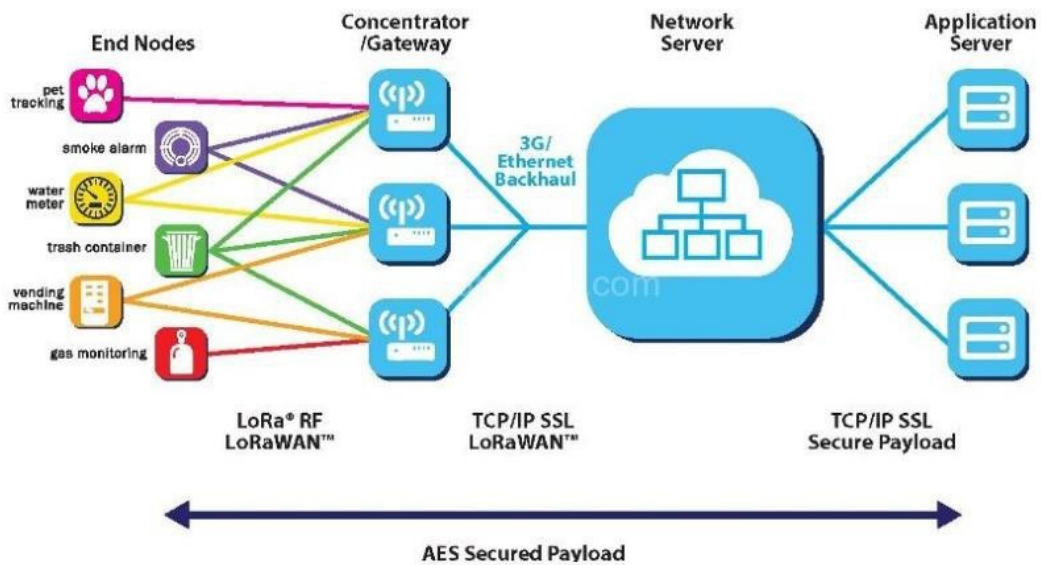

Fig. 1.3: LoRaWAN (taken from [7])

1.3 LoRa PHY layer

1.3.1 LoRa Modulation

LoRa modulation uses a Chirp Spread Spectrum (CSS) modulation. This modulation uses chirp pulses as a carrier signal. Chirp is a sinusoidal signal, where frequency linearly increases (upchirp) or decreases (downchirp) over time (see fig 1.4). Information is stored in ‘frequency jumps’ (see fig 1.5). This modulation type is resistant to the Doppler effect, has high robustness, and is suitable for urban use thanks to its high multipath/fading resistance. CSS is a type of constant envelope modulation, which is essential for low power consumption[4, 10, 11]. LoRa can also use Gaussian Shift Keying Modulation (GFSK), which is discussed in section 2. The block diagram of LoRa PHY with available modulations is shown in the figure 1.6. Parameters for the following figures (fig. 1.4 and fig. 1.5) were selected for demonstration purposes. Time-domain modulated signal with real modulation parameters would be difficult to see.

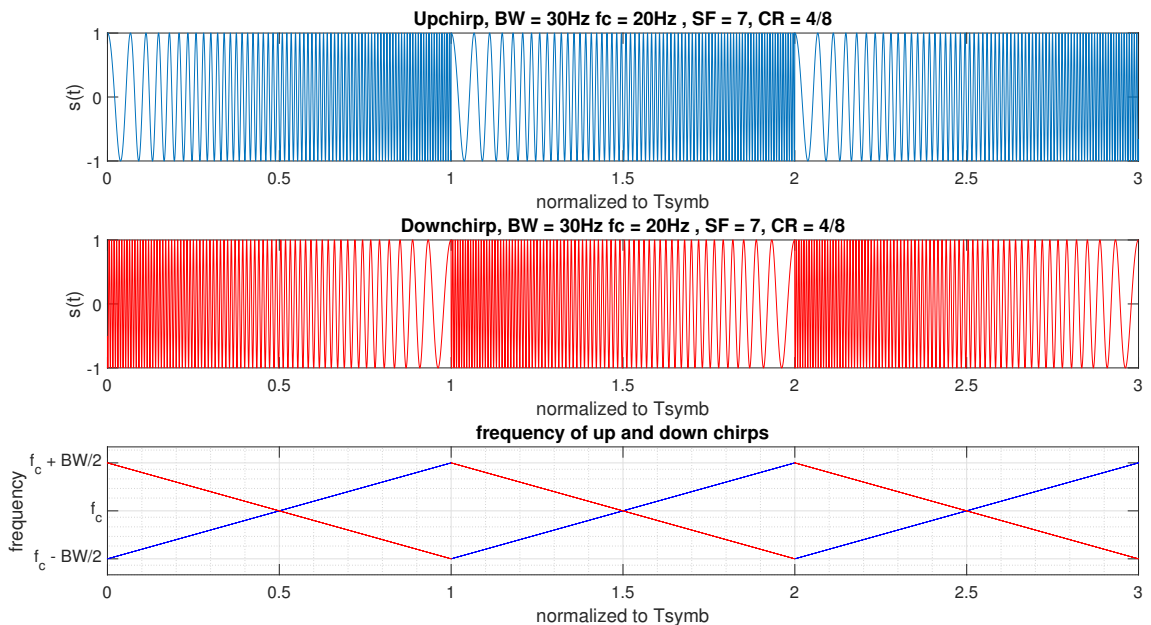

Fig. 1.4: Upchirps (blue), Downchirps (red) and their frequency in time domain

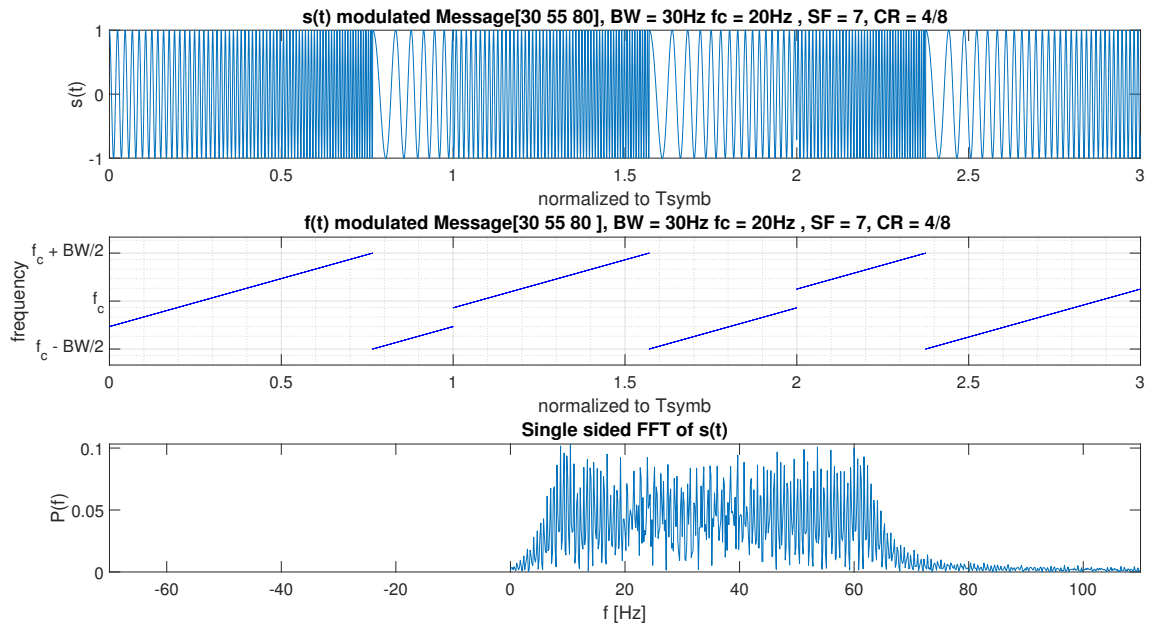

Fig. 1.5: Message modulated in frequency jumps and FFT of signal

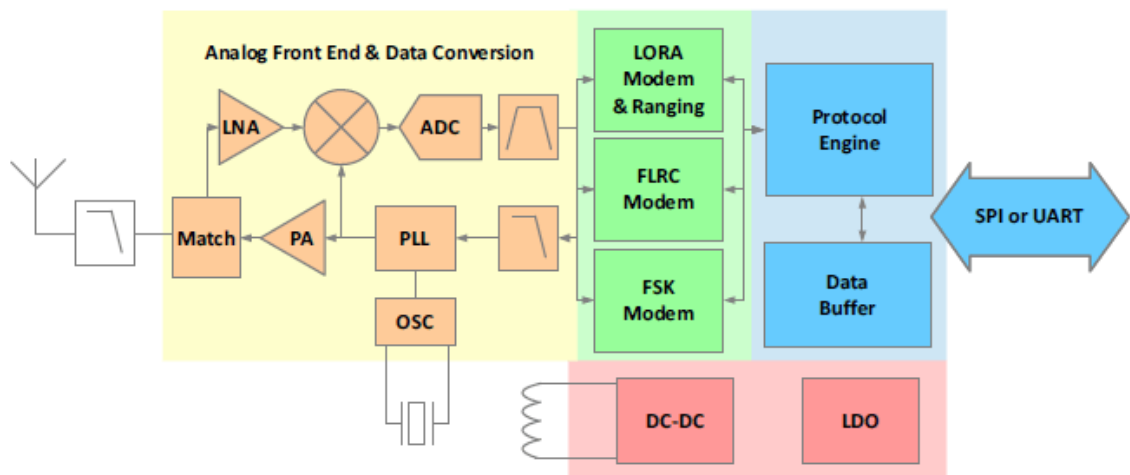

Fig. 1.6: LoRa PHY layer block diagram, (taken from [12])

1.3.2 LoRa Bandwidth

Bandwidth (BW) of LoRa sub-GHz systems can differ from 7.8 kHz up to 500 kHz. In the 2.4 GHz ISM band, has the following options of BW (200, 400, 800, and 1600 kHz). BW has a direct relation to chirp rate R_c , for instance, if BW = 400 kHz, chirp rate = 400 kcps.

The higher is the BW, the higher is the data rate. However, increasing BW also has a negative effect on the receiver's sensitivity and on the noise in the channel.

BW, together with the Spreading Factor (SF), determines the symbol period T_s [4, 10]:

$$T_s = \frac{2^{SF}}{BW} \quad (1.1)$$

1.3.3 Spreading factor

The Spreading Factor (SF) represents the number of bits in a single chirp. Single chirp is then divided into 2^{SF} chips. SF can also be written as a ratio of Symbol Rate R_s and R_c .

$$2^{SF} = \frac{R_c}{R_s} \quad (1.2)$$

For the implementation of LoRa wireless communication, we can select values of SF from 5 to 12. SF affects the receiver's sensitivity. Higher SF improves the receiver's sensitivity and lowers the data rate (see fig. 1.7, where the symbol period is rising together with SF). LoRa can run in mode, where SF is automatically set by a network server or by gateways. This option can improve power consumption [10, 11].

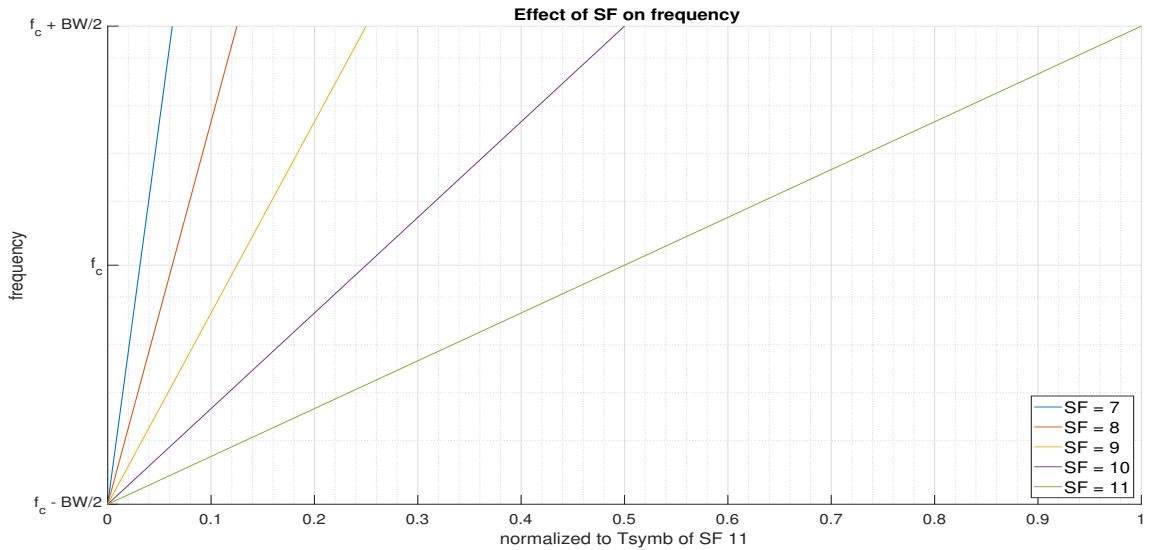

Fig. 1.7: Relationship between SF and symbol rate

1.3.4 Coding Rate

The CR defines the level of Forward Error Correction (FEC). This technique adds redundant (parity) bits to the transmission to avoid (recover) errors. LoRa supports CRs, namely: CR 4/5, 4/6, 4/7 and 4/8. The value of CR represents the proportion of transmitted bits that carry information to all transferred bits. With

higher CR, we achieve more reliable transmission. On the other hand, we need to transmit more bits to send the same message. Bit rate can be calculated using the following formula [4, 10]:

$$bitrate = SF \cdot \frac{BW}{2^{SF}} \cdot CR \quad (1.3)$$

1.4 Frequency bands and channels

LoRa was initially designed for the sub-GHz bands. In the sub-GHz bands, LoRa occupies different channels in different countries and regions. Each supported region has its ‘frequency plan’. For example, Czech Republic has a frequency plan EU863-870. This plan fully specifies the LoRa parameters [9]. Nowadays, LoRa can also operate in the 2.4 GHz ISM band. In the 2.4 GHz ISM band, LoRa parameters slightly differ from the sub-GHz bands (see Table 1.1).

Tab. 1.1: LoRa, available Bandwidth and spreading factor settings according to RF band

EU863-870		US902-928		ISM 2.4 GHz	
BW [kHz]	SF	BW [kHz]	SF	BW [kHz]	SF
125, 250	7-12	125, 500	7-10	200, 400, 800, 1600	5-12

1.5 LoRa frame

LoRa has an explicit and implicit option for its frame. The LoRa frame consists of three parts: preamble, header and payload (fig. 1.8). In explicit frame, the preamble usually consists of 8 upchirps and 2+1/4 of downchirp. The header contains information about payload length, CR and Cyclic Redundancy Check (CRC) of the header. The payload carries transmitted message with length up to 255 bits and can be optionally followed by the 16 bit CRC.

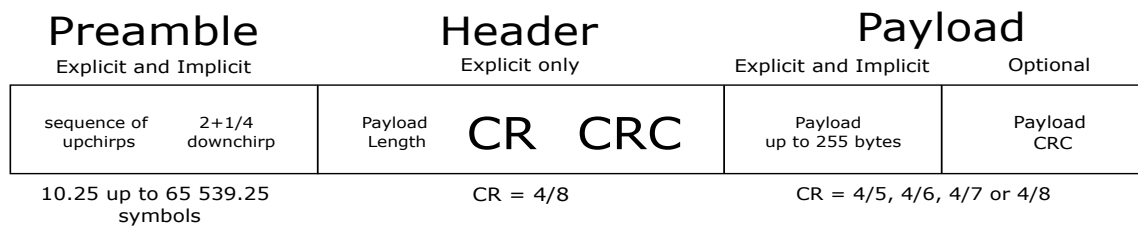

Fig. 1.8: Lora Frame

The implicit frame has the preamble, followed by a payload without a header. For successful transmission, the receiver and transmitter must have the same settings. The total number of symbols can be calculated by eq. 1.4, where DE (0 or 2) is slow data rate optimization, PL is payload length, H (0 or 20) is the header, CRC (0 or 16), and SF (5 up to 12) and CR (1 up to 4) [13].

$$n_s = 8 + \max \left(\text{ceil} \left(\left(\frac{8 \cdot PL - 4 \cdot SF + 8 + CRC + H}{4 \cdot (SF - DE)} \cdot (CR + 4) \right), 0 \right) \right) \quad (1.4)$$

2 Bluetooth

2.1 Bluetooth Introduction

Bluetooth is a member of Wireless Personal Area Network (WPAN), which is defined by a working group 802.15 (802.15.1, especially for Bluetooth) of the Institute of Electrical and Electronics Engineers (IEEE). This network is used to transfer data over short distances (tens of meters) between personal (local) devices wirelessly. In comparison with LPWAN, WPAN has very low (or none) requirements for network infrastructure, because devices can be connected directly without need of gateways [14].

2.2 Piconet and Scatternet

The Piconet protocol defines network architecture for devices that uses Bluetooth to communicate. This network provides a point-to-point or point-to-multipoint connection. In single Piconet, only one of the devices acts as the master and others as the slaves. However, slaves can participate in different Piconets, and also masters can participate as slaves in different Piconets. If Piconets has common devices, the network is called Scatternet [14].

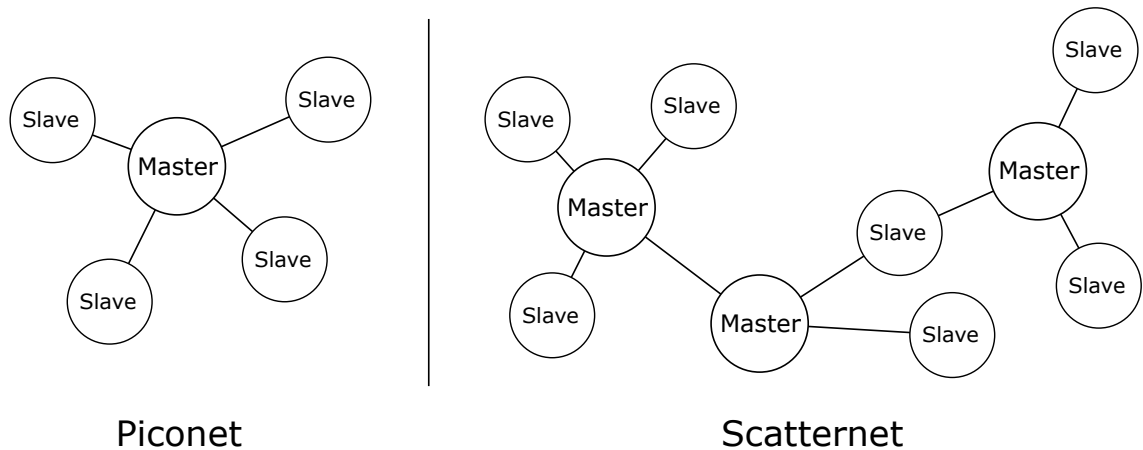

Fig. 2.1: Piconet and Scatternet

2.3 Bluetooth PHY

2.3.1 Bluetooth Modulation

Bluetooth modulation is based on Frequency Hopping Spread Spectrum (FHSS) and Gaussian Frequency Shift Keying (GFSK) modulation. GFSK is a form of Continuous Phase Frequency Shift Keying (CPFSK) modulation derived from Binary Frequency Shift Keying (BFSK). Parameters for all following figures in Bluetooth section were selected for demonstration purposes, because time-domain modulated signal with real modulation parameters would be difficult to see.

BFSK

BFSK is a type of digital FM modulation, where the message is encoded into two discrete frequencies. The time-domain signal can be described as follows:

$$t(s) = Amp \cdot \cos(2\pi f(t) \cdot t) \quad (2.1)$$

Assume that the input message $D(n)$ is a regular n -bit sequence of HIGH and LOW levels, where each bit has time duration T_b and assign f_1 and f_2 to the logical LOW and HIGH level of $D(n)$, respectively. Therefore, frequency becomes a function of $D(n)$. Usually, frequencies f_1 and f_2 are symmetrical according to the center frequency f_c . Therefore, the modulation index is defined as: $I_m = \Delta f / f_c$, where $\Delta f = f_2 - f_1$.

$$\begin{aligned} f(D(n)) : \text{if } D(n) = \text{HIGH}, f = f_1 = f_c - \frac{I_m \cdot f_c}{2} \rightarrow s(t) = Amp \cdot \cos(2\pi f_1 \cdot t) \\ \text{if } D(n) = \text{LOW}, f = f_2 = f_c + \frac{I_m \cdot f_c}{2} \rightarrow s(t) = Amp \cdot \cos(2\pi f_2 \cdot t) \end{aligned} \quad (2.2)$$

Therefore,

$$s(t) = Amp \cdot \cos(2\pi f(D(n)) \cdot t) \quad (2.3)$$

In fig. 2.2 we can see the discontinuities of the signal phase whenever $D(n)$ changes its value. This can cause problems during the signal amplification process.

CPFSK

To solve problems with discontinuities, we need to correct the phase of signal. There are several methods to do this. For example, assume that we want to find

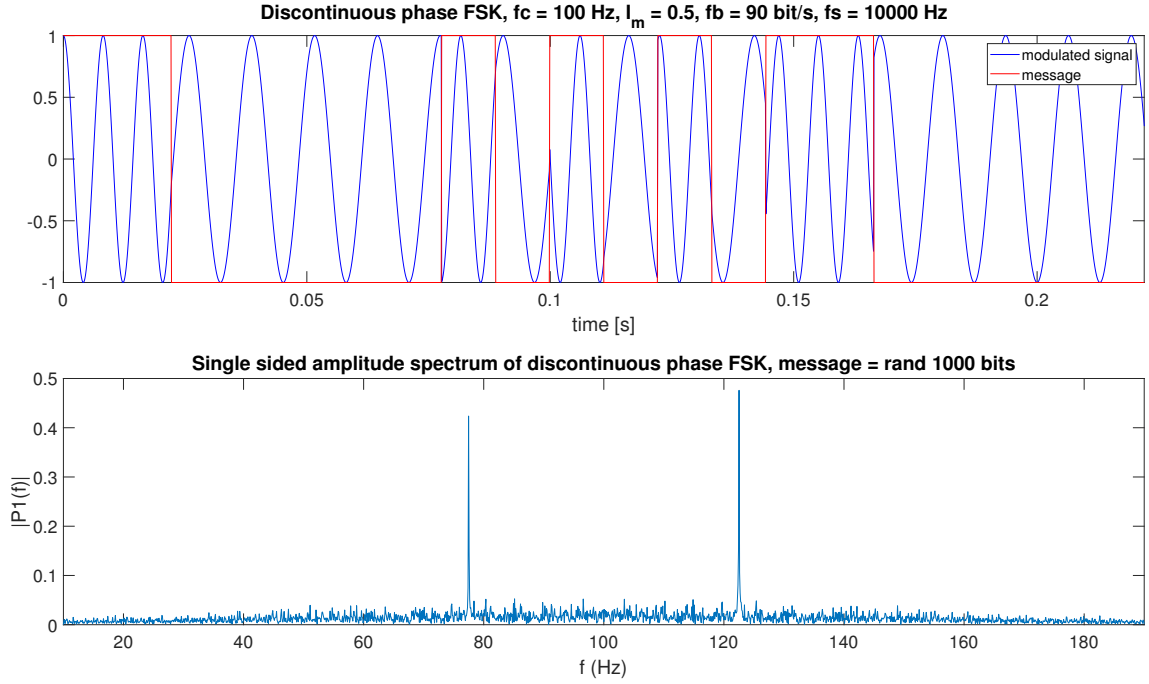

Fig. 2.2: BFSK modulation: time domain signal and its spectrum

phase shift φ_{T_b} in time $T_b = \frac{1}{f_b}$, where f_b is bit rate [15].

$$\begin{aligned}
 \cos(2\pi f(D(1)) \cdot T_b) &= \cos(2\pi f(D(2)) \cdot T_b + \varphi_{T_b}) \\
 \cos(2\pi f_1 \cdot T_b) &= \cos(2\pi f_2 \cdot T_b + \varphi_{T_b}) \\
 \varphi_{T_b} &= 2\pi T_b (f_1 - f_2)
 \end{aligned} \tag{2.4}$$

If we try to find φ_{2T_b} in time $2T_b$, we will need to add the previous phase φ_{T_b}

$$\begin{aligned}
 \cos(2\pi f(D(2)) \cdot 2T_b + \varphi_{T_b}) &= \cos(2\pi f(D(3)) \cdot 2T_b + \varphi_{2T_b}) \\
 \cos(2\pi f_2 \cdot 2T_b + \varphi_{T_b}) &= \cos(2\pi f_1 \cdot 2T_b + \varphi_{2T_b}) \\
 \varphi_{2T_b} &= 2\pi 2T_b (f_2 - f_1) + \varphi_{T_b}
 \end{aligned} \tag{2.5}$$

In general, phase correction can be evaluate as:

$$\varphi(n) = \sum_{n=1}^k 2\pi (f(D(n)) - f(D(n+1))) \cdot n \cdot T_b + \varphi_0, \tag{2.6}$$

where $k = \text{number of bits}$, $\varphi_0 = \text{initial phase}$

Note that $\varphi(n)$ was calculated only for discrete times $n \cdot T_b$, because we work with discrete frequencies. If the frequency changes continuously in time, the sum becomes an integral (eq. 2.7)

$$\varphi(t) = \int_0^t (2\pi (f(D(t)) - f(D(t+dt))) \cdot t) \cdot dt + \varphi_0 \tag{2.7}$$

Because CPFSK modulation is used in digital systems, the dt is approximately $T_s = 1/f_s$, where T_s and f_s are sampling period and sampling frequency, respectively. $D(n)$ is message sampled by time intervals T_s . Therefore, we can finally evaluate phase correction [15]:

$$\varphi(n) = \sum_{n=1}^k 2\pi(f(D(n \cdot T_s)) - f(D(n \cdot T_s + T_s)) \cdot n \cdot T_s + \varphi_0, \quad (2.8)$$

where $k = \text{number of bits} \cdot f_b$

And time domain phase corrected signal:

$$s(n \cdot T_s) = \cos(2\pi f(D(n \cdot T_s)) \cdot n \cdot T_s + \varphi(n)) \quad (2.9)$$

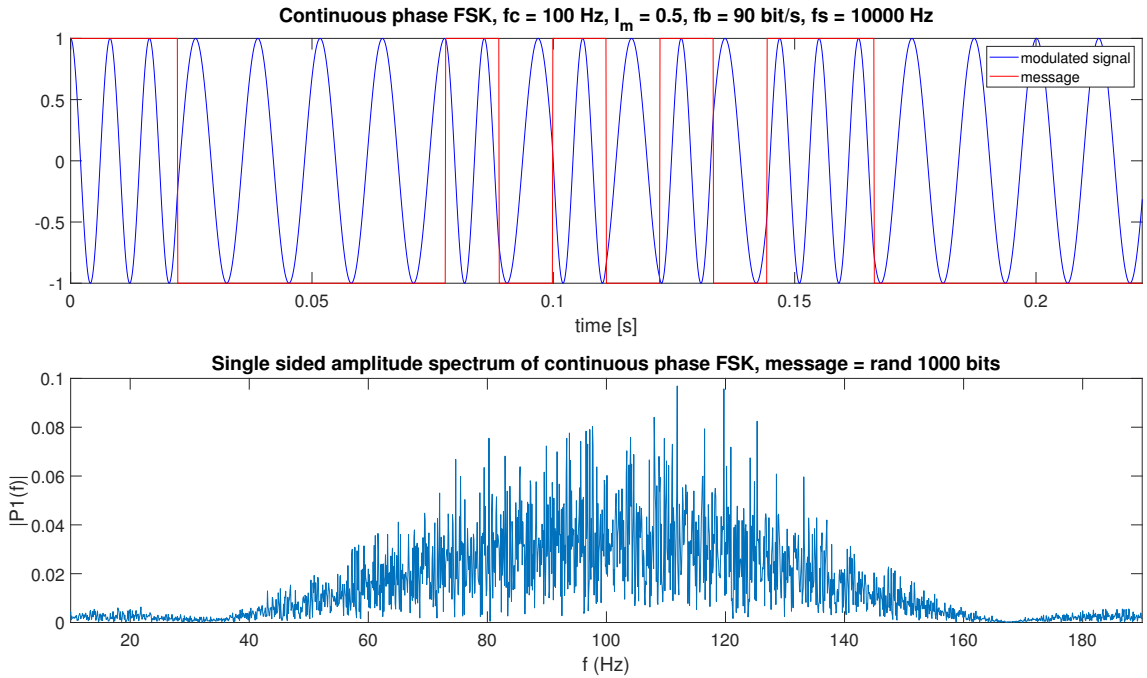

Fig. 2.3: CPFSK modulation time domain and spectrum

GFSK

GFSK uses a similar concept as CPFSK to achieve a continuous phase signal. The only difference is that the input signal is firstly filtered by a Gaussian filter, whose transfer function and impulse response can be seen in Figure 2.4, and then modulated (see fig. 2.5). The purpose of filtering is to make the spectrum of the signal narrower. Gaussian filter is used for its well-behaved time-domain impulse

response $h(n)$. The transfer function of the Gaussian filter is represented by eq. 2.10, where f_{-3dB} is the cut off frequency [15].

$$H(f) = A_0 e^{-\alpha(2\pi f)^2} \cdot e^{-j2\pi f \cdot t_0}$$

$$\alpha = \frac{\ln(2)}{2(2\pi f_{-3dB})^2}$$
(2.10)

and impulse response is a bell shaped function.

$$h(n) = \frac{A_0}{\sqrt{\pi}} \beta e^{-\beta(t-t_0)^2}$$

$$\beta = \sqrt{\frac{2}{\ln 2}} \pi f_c \cdot BT,$$
(2.11)

where roll off factor $BT = \text{filter Bandwidth} \cdot T_b$. The convolution of $h(n)$ and $D(n)$ returns the time domain filtered signal. Filtered signal $filt(n)$ is a continuous signal sampled by f_s , therefore equation 2.8 is used for phase corrections. After some corrections, we end with this formula for time domain signal (see fig. 2.5) [15].

$$s(n) = A_0 \cos \left[2\pi f_c \cdot n + \frac{2T_b \pi I_m}{2} \sum_0^n \frac{T_b \cdot filt(n)}{2} \right]$$
(2.12)

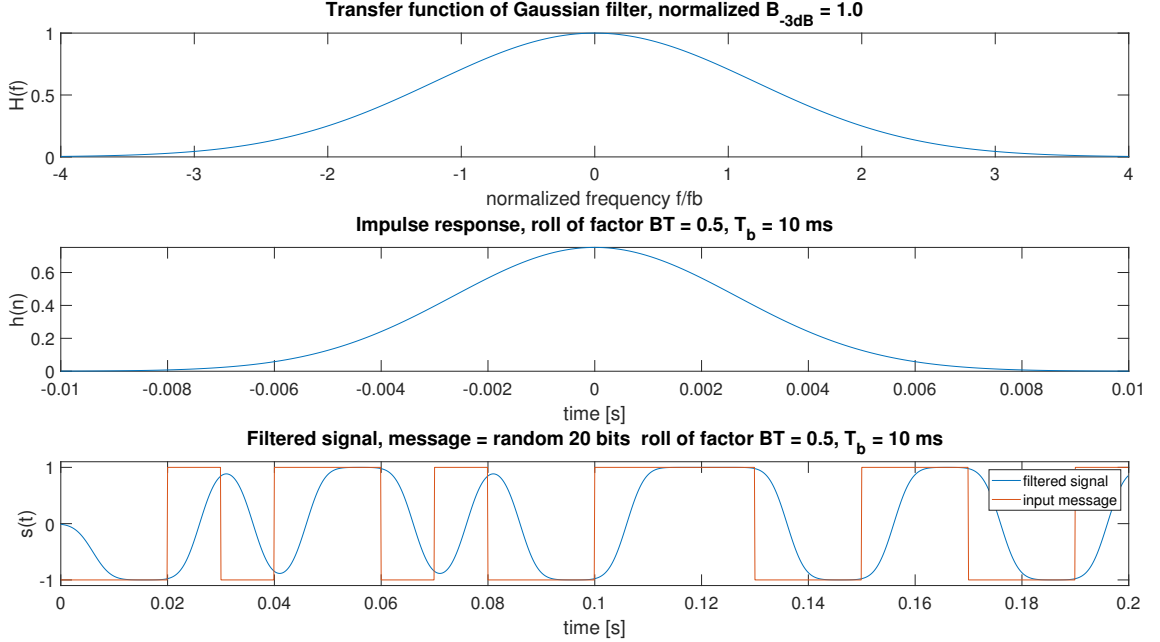

Fig. 2.4: Gaussian filter: Transfer function, impulse response and filtered input message

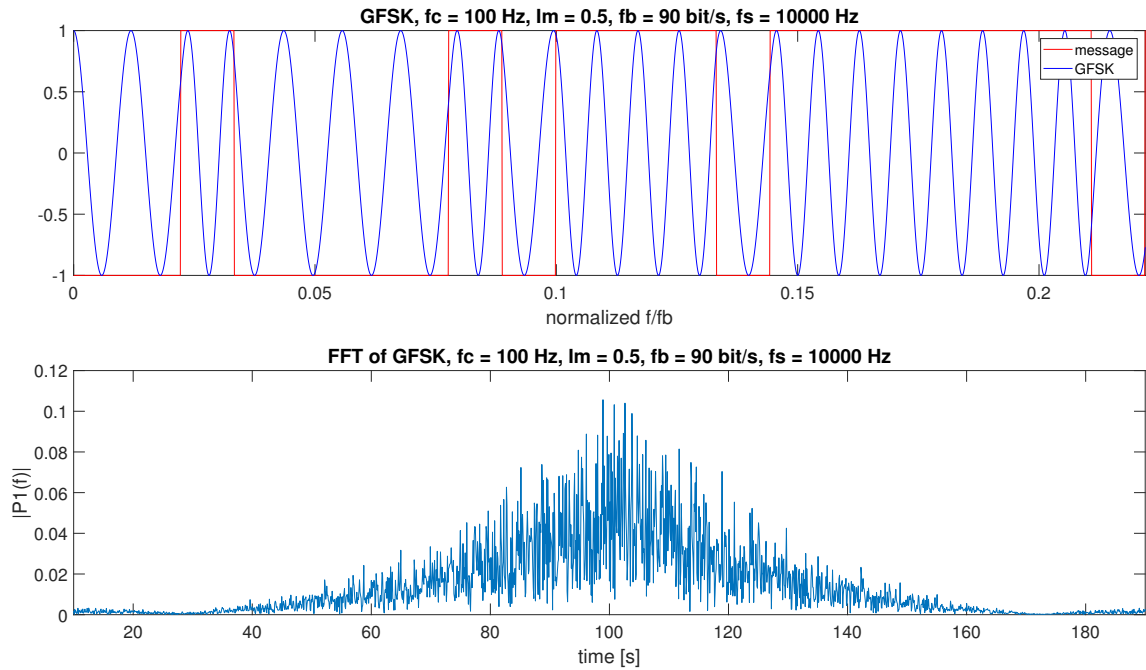

Fig. 2.5: GFSK modulation time domain and spectrum

FHSS

FHSS modulation distributes f_c to the appropriate channels in a pseudo random pattern (see fig. 2.6).

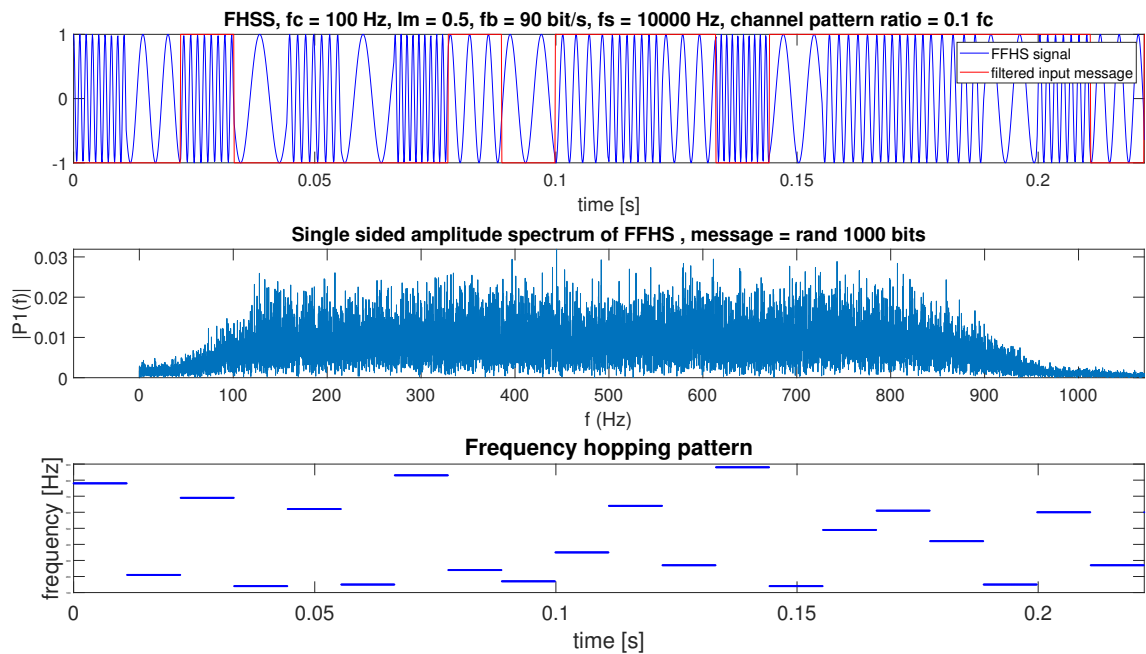

Fig. 2.6: FHSS modulation time domain, spectrum and frequency pattern

This method helps to avoid coexistence with other technologies in the 2.4GHz ISM band and at the same time improves transmission security. If a Bluetooth device detects interference in one of the channels, it automatically tries to avoid these channels by changing the pattern.

2.3.2 Modulation parameters

Bluetooth can operate in Basic Rate (BR) or Enhanced data rate (EDR) mode. In this thesis, all measurements are related to the basic rate mode.

BR mode uses GFSK modulation with BW of 1 MHz, modulation index I_m between 0.28 and 0.35, BT of Gaussian filter 0.5, data rate = 1 Mbps, and frequency hopping at the nominal rate of 1600 hops/s. In addition, the minimum frequency deviation should not be lower than 115 kHz. This mode is designed for devices that need to continuously communicate with each other, such as wireless headphones and hands-free.

The EDR mode uses two types of PSK modulation, the $\pi/4$ -DQPSK or 8DPSK, and achieves data rates of 2 Mbps and 3 Mbps, respectively [14, 16].

2.4 Frequency bands and channels

Bluetooth operates in 2.4 GHz ISM band and can occupy 79 RF channels in the following pattern:

$$f_c = 2402 + k \text{ MHz}, \quad (2.13)$$

where $k = 0,1,2,\dots,78$, f_c is the center frequency of channel and each channel has BW of 1 MHz.

3 Coexistence Scenarios

Since LoRa and Bluetooth can operate in the same 2.4 GHz ISM band, they can also share the same RF channel. In this thesis, the following types of coexistence scenarios are considered: Co-Channel Coexistence Scenario (CSSS), In-Band Coexistence Scenario (INCS), Adjacent Channel Coexistence scenario (ACCS), and Out-Band Coexistence Scenario (OBCS).

In CSSS, both systems work with the same carrier frequency. This scenario is potentially the worst from the view of interferences because most power of the interferer signal is concentrated around the carrier frequency.

On the other hand, in ACCS and INCS signals have different carrier frequencies, but coexistence occurs because their bands overlap each other. In our case, the main parameter of ACCS and INCS is the frequency offset Δf , which defines the offset between the carrier frequency of the interfering (unwanted) Bluetooth signal and the carrier frequency of the wanted LoRa signal. In general, the larger the Δf , the less likely systems will interfere each other.

OBCS presents a case with non-overlapping RF spectrums. To avoid interferences between two signals, that has their spectrums close to each other, we define a Guard Band (GB) as an unused part of the radio spectrum between RF bands [4].

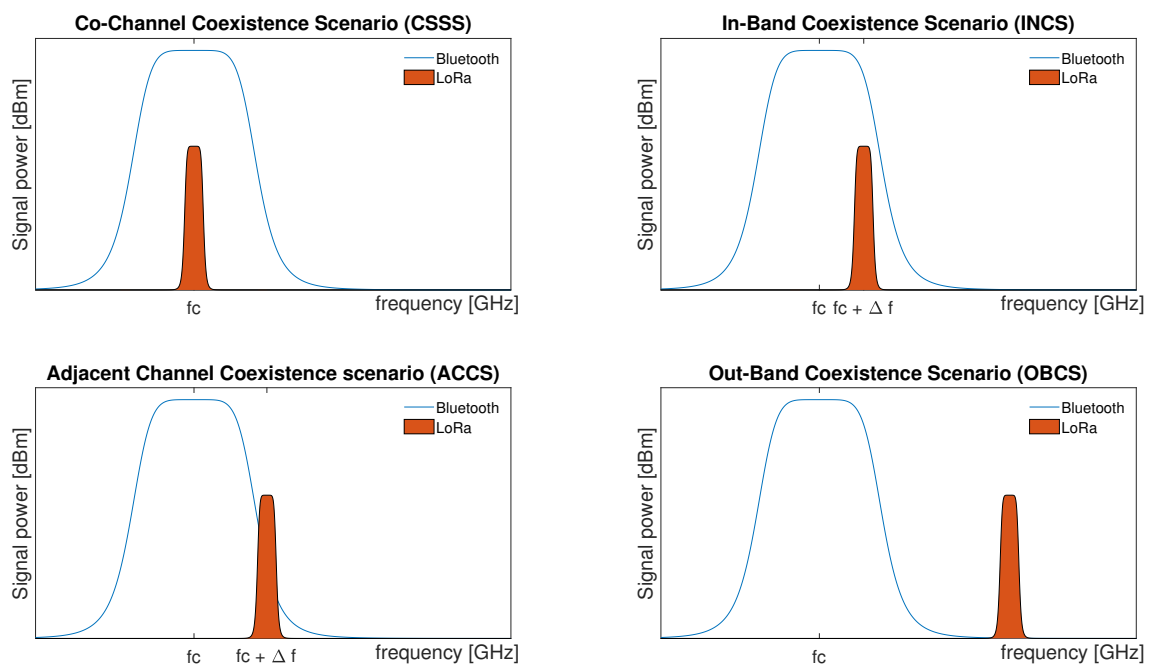

Fig. 3.1: Coexistence scenarios

As an example of coexistence (see fig. 3.2), We suppose that the Bluetooth signal is transmitted in channel 2. Next, the LoRa signal has BW of 400 kHz and f_c equals to 2403 MHz. Because both systems share the same f_c , they are in a CSSS.

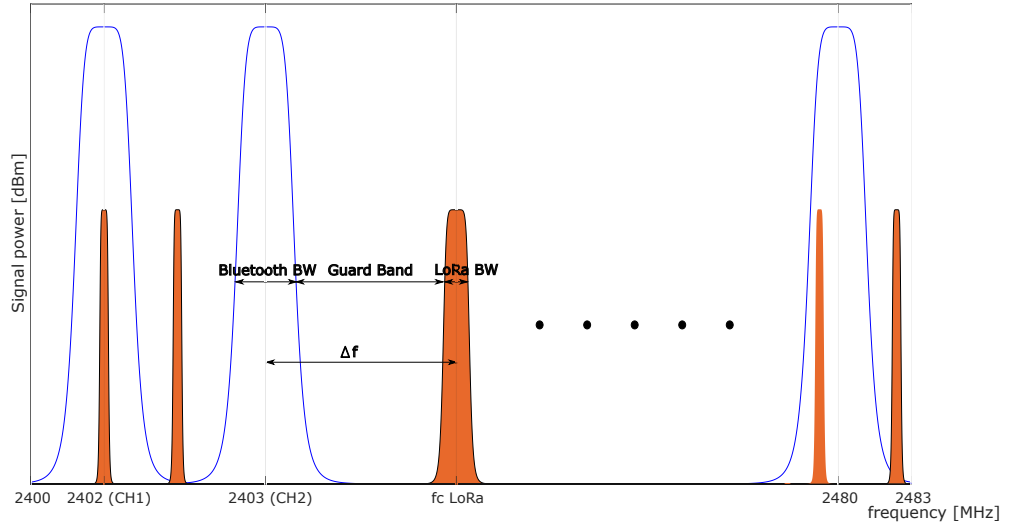

Fig. 3.2: Possible coexistence of LoRa and Bluetooth systems in the 2.4 GHz ISM band

If we increase the f_c of LoRa up to the 2403.7 MHz (Δf up to $(BW_{Bl} + BW_{LoRa})/2 = 0.7 \text{ MHz}$), systems will have no longer the same f_c and move from CSSS into INCS and ACCS. In these scenarios interference may occur, because spectra of the systems overlap each other. By further increasing the f_c , systems achieve case of OBCS, in which the systems have GB between each other and should not interfere.

4 Measurement methodology

4.1 Measured parameters

Measurement of Protection Ratio (PR) is one of the methods to define immunity of a wireless communication system to interference caused by other wireless communication system. In our case, PR is calculated as the ratio of C/I for Packet Error Rate (PER) of 10%, where C is the power of the LoRa signal and I is the power of the Bluetooth signal. PER represents the ratio of incorrectly received data packets and the number of all received packets expressed in percents, where the value of 10% represents the „threshold“ of reliable transmission for LoRa systems [4]. However, to get a better idea of the system’s immunity, it is advisable to measure the dependence of the PR on Δf . C and I are measured in dBm, therefore PR can be calculated as:

$$PR [dB] = C - I \quad (4.1)$$

4.2 Measurement testbed

The measurement of coexistence scenarios between LoRa and Bluetooth systems was performed for various combinations of parameters SF and BW (see Table 4.1) of the LoRa system, where these parameters have the most significant effect on the result of measurements.

Tab. 4.1: Measured combinations of LoRa PHY

BW 200			BW 400			BW 800			BW 1600		
SF	CR	C [dBm]	SF	CR	C [dBm]	SF	CR	C [dBm]	SF	CR	C [dBm]
5	4/5	-65	5	4/5	-65	5	4/5	-65	5	4/5	-75
6	4/5	-65	6	4/5	-65	6	4/5	-65	6	4/5	-75
8	4/5	-65	8	4/5	-65	8	4/5	-65	8	4/5	-75
10	4/5	-65	10	4/5	-65	10	4/5	-65	10	4/5	-75
12	4/5	-65	12	4/5	-65	12	4/5	-65	12	4/5	-75

The LoRa signal (C) was generated by using SK-iM282A module and individual physical layer parameters were set using WiMoD LR studio. The output power of the TX signal was set to the lowest possible level (-18 dBm). Next, the LoRa signal was attenuated to the level (see table 4.1) in order to achieve PER = 10% for the highest possible Δf with the limited maximum power (-5 dBm) of the Bluetooth

signal (I) generated with the help of R&S SMU200A arbitrary signal generator. Finally, both signals were combined in a Wilkinson power combiner/splitter and split into two signal paths. First one leads to the Rx LoRa module and second one to the R&S FSQ Spectrum Analyzer. The purpose of the Rx LoRa module was to measure PER, and the purpose of the spectrum analyzer was to reliably measure the output power of C and I signals (fig. 4.1).

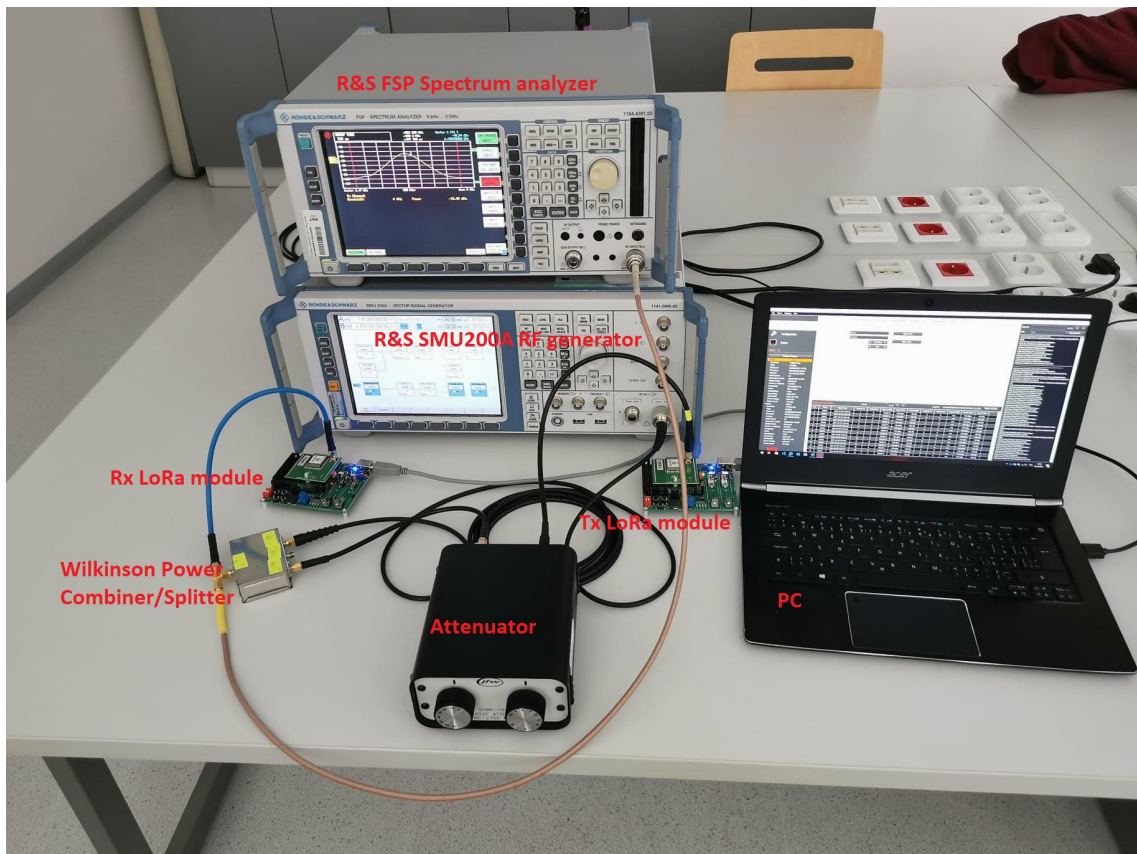
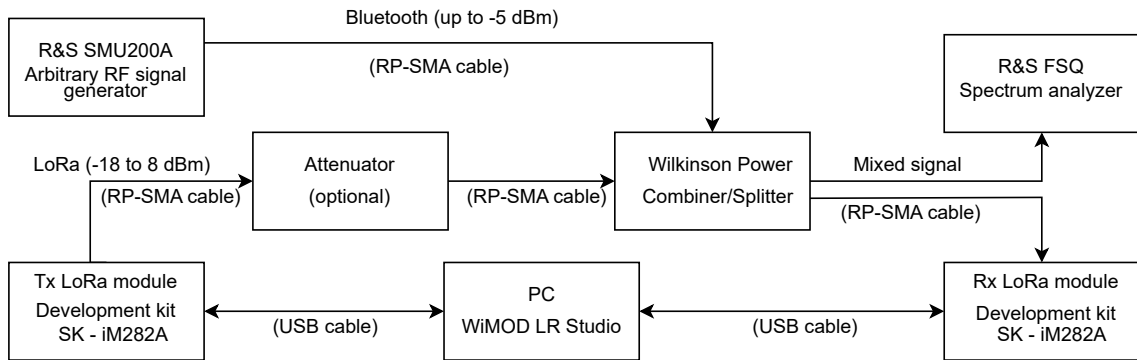

Fig. 4.1: Block diagram and photo of measurement testbed

The measurement process was performed in the following steps:

1. Setup LoRa signal C using WiMOD LR studio (SF, BW, CR, f_c). The proposed output power levels of attenuated output power of Tx LoRa module can be found in the table 4.1. Proposed output power levels are measured by the FSQ spectrum analyzer. Because the test, performed by the WiMOD LR studio, uses bidirectional communication between the Tx and Rx modules, it is necessary to disconnect the Rx module when the power level of Tx module is measured. This signal remains unchanged during the measurement of one combination of parameters from the table 4.1.
2. Setup Bluetooth signal I using R&S SMU 200A generator. The proposed initial output power is at least 10 dB lower than the LoRa power level. The output power of Bluetooth signal is measured by an R&S FSQ, while both LoRa modules are disconnected.
3. Adjust the power level of Bluetooth signal I to achieve a required condition of 10% PER for LoRa reliable communication. Measure the output power of the Bluetooth signal in the same way as was described in step 3.
4. PR (C/I) parameter is calculated from steps 2 and 4 using equation 4.1
5. Repeat steps 1 to 5 varying frequency offset Δf (starting from $\Delta f = 0$). The step Δf_{step} is different for each BW of LoRa signal and is discussed in the experimental part.

Each step of measurement is related to the different combination of LoRa PHY parameters. However, the center frequency f_c of LoRa remains constant for all measurements (2.47 GHz). Therefore, the frequency offset depends only on the center frequency of the Bluetooth signal.

4.3 Hardware and Software description

4.3.1 LoRa SK-IM282A module and WiMOD LR studio

LoRa modules SK-iM282A (fig. 4.2) are long-range modules produced by Semtech company designed to operate in the 2.4 GHz band. These modules can communicate directly with each other without the need of gateways. Modules can be controlled by the Windows app, called WiMOD LR Studio, developed by SEMTECH company. This program offers Graphical User Interface (GUI), where a user can set and monitor several parameters of LoRa system. The communication between LoRa modules and WiMOD LR studio is based on a USB interface. SK-iM282A modules must be firstly correctly configured (shorting onboard pins with jumpers) according to the datasheet. After all necessary configurations, SK-iM282A modules can be connected via USB cables to the PC, and software should automatically detect the modules.

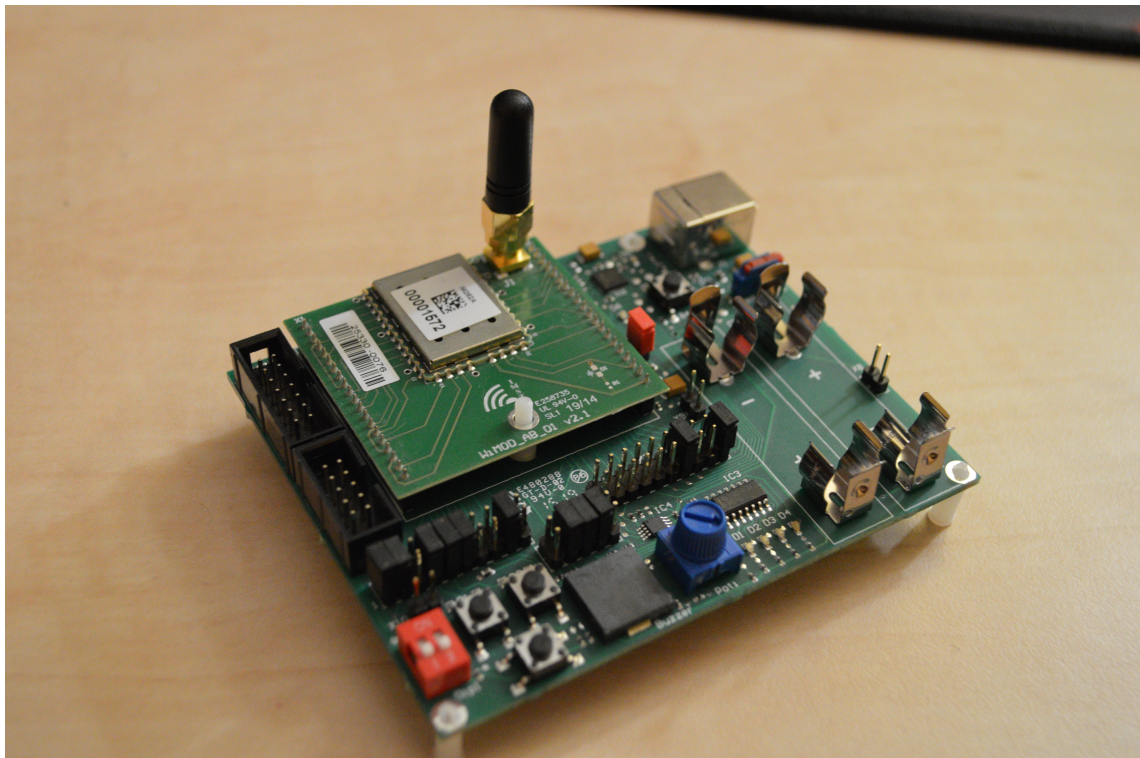

Fig. 4.2: LoRa SK-IM282A module

GUI has vertical and horizontal bars for more straightforward navigation in the program (see fig. 4.3). We can enter into three sections in the vertical navigation bar, namely: Radio Services, Configuration, and Extras. In the Configuration section, the PHY parameters can be configured according to the Table. 4.2.

Tab. 4.2: Available parameters in WiMOD LR Studio

Parameter	Description
RF Carrier Frequency	2402 000 143 Hz up to 2479 999 939 Hz with step approx. 198 Hz
Modulation	LoRa, FLRC, GFSK
BW (LoRa)	200 kHz, 400 kHz, 800 kHz, 1600 kHz
SF	5 up to 12
CR	4/5 up to 4/8
Output power	-18 dBm up to 8 dBm

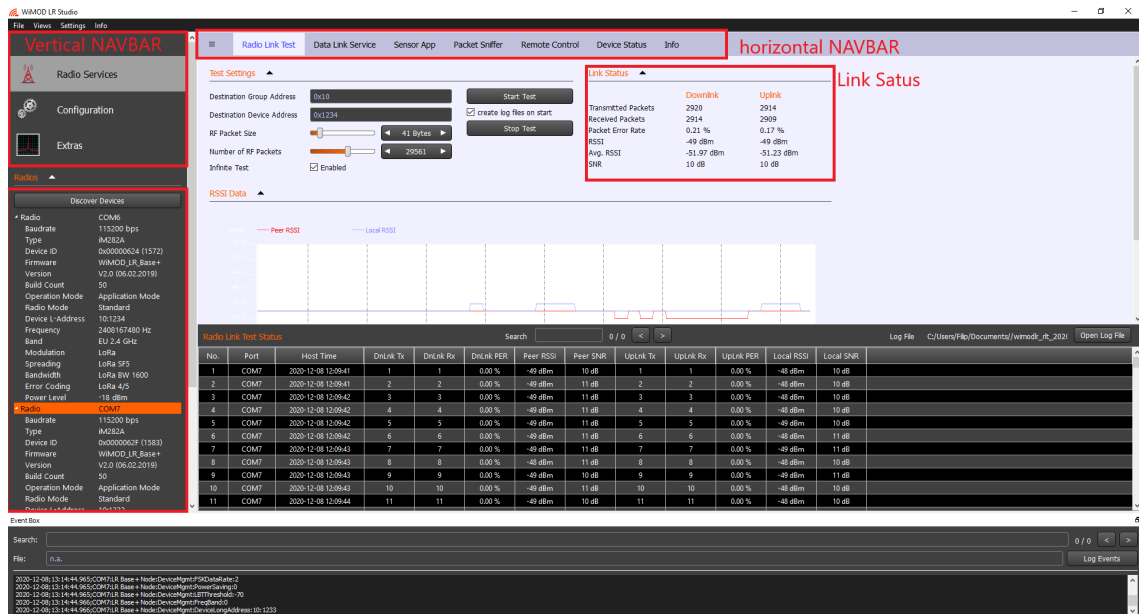

Fig. 4.3: WiMOD LR Studio GUI

We can start a test in the Radio Services section and open a link between the two LoRa modules. WiMOD LR studio ensures automatical measurement of Packet Error Rate and Received Signal Strength Indicator (RSSI) and print their value in the link status (see fig. 4.3). RSSI is an estimated power level that the device is receiving from another device. According to the radio settings, one device is marked as local, and the other as a peer device. Transmission from a local to a peer device is called ‘downlink’ while transmission from a peer to a local device is called ‘uplink’.

4.3.2 R&S SMU200A

The R&S SMU200A is a two-channel (A and B channels) arbitrary RF signal generator with an option to upload or create custom signals. Channel A is capable of generating a signal in a frequency range from 100 kHz up to 6 GHz. Channel B has a frequency range only up to 3 GHz. The maximum output power of the generator is 5 dBm.

4.3.3 R&S FSQ

R&S FSQ is a signal analyzer, which is capable of RF signal measurement up to 8 GHz. It has a feature to measure power levels in a selected RF channel. In this thesis, this device is used to display RF spectrums of Bluetooth and LoRa (or mixed) signals and to measure their power.

5 Experimental measurements

This chapter presents the results of the experimental measurements, which are described in previous section. Measurements were performed for different combinations of LoRa PHY parameters (see table 4.1). For each of combination of parameters, the dependence of PR on Δf was measured. Results are represented in a graphical form and discussed in the following subsections. The combinations of parameters are chosen to cover the extremes that may occur in the measured coexistence scenarios, while SF = 5 and SF = 12 for the given BW of LoRa signal are considered as extremes. The measured PR dependencies on Δf for other SFs should stay between these extremes.

The maximum value of the reached Δf_{max} varies depending on the limited output power of the Bluetooth signal generator and the combination of PHY parameters of the LoRa system. From the maximum reached Δf_{max} , the minimum step between individual Δf s is derived, to compromise, between the time complexity and the resolution of measurements. For each BW of the LoRa system, the RF spectra of the measured signals (Bluetooth and LoRa) for individual extremes (SF = 5 and SF = 12) at $\Delta f = 0$ and Δf_{max} are shown in the relevant figures. All spectra were measured by a R&S FSQ spectrum analyzer (BW = 4 MHz, VBW = 3 MHz, SWT = 12 s) and processed offline in MATLAB.

For all measurements a Bluetooth BR signal, with the following PHY layer parameters, was used:

Tab. 5.1: Bluetooth PHY parameters

Modulation	BT of Gaussian filter	BW	FHSS
GFSK	0.5	1 MHz	disabled

In order to set the required Δf , the Bluetooth Basic Rate signal (hereinafter referred as the Bluetooth) was generated without FHSS modulation.

Parameter PER was measured using WiMOD LR studio and SK-IM282 LoRa modules, where the evaluation took place after 100 sent packets, each with a length of 15 bytes. Such a small number of packets was chosen to speed up the measurement. Due to the small number of packets, it was not possible to accurately determine the PR at PER = 10%. Therefore, a PER value of $10 \pm 5\%$ was tolerated for the I signal power level adjustments.

5.1 LoRa: BW = 200 kHz

This section is dedicated to the measurement of coexistence scenarios for the following combination of LoRa and Bluetooth PHY parameters.

Tab. 5.2: Parameters of LoRa and Bluetooth PHY

LoRa						Bluetooth		
modulation	BW [kHz]	SF	C [dBm]	CR	f_c [GHz]	modulation	BW [MHz]	Symbol Rate
LoRa (CSS)	200	5,6,8,10,12	-65	4/5	2.47	GFSK	1	1Msym/s

The maximum Δf_{max} that was achieved during the measurement was 700 kHz with Δf_{step} of 100 kHz. It implies that the measurement includes CSSS and INCS. In the Fig. 5.1 the individual dependencies of PR (C/I) on Δf for different SFs can be seen. In general, the lower the PR, the more resistant the system is. Therefore, it can be concluded that LoRa is the most resistant to interference at SF = 12 and the lowest resistance against interferences has at SF=5. This corresponds with the assumption, which implies that with higher SF the receiver has higher sensitivity.

If we calculate the PR at $\Delta f = 0$, we obtain information about the immunity of LoRa system in the CSSS. As an example, consider SF = 12, where PR = -26.7 dB was measured at $\Delta f = 0$. That means, it is possible to reliably receive a LoRa signal with approximately 470x lower power than an interfering Bluetooth signal at the same f_c . For comparison, consider the same example, but with SF = 5. For this SF, PR = -17.72 dB was measured, therefore 52 times weaker LoRa signal can be reliably received. It seems that SF has no significant effect on the shape of obtained curves and affects only the amplitude of measured PRs.

In the case of scenario INCS ($\Delta f > 0$). There is decreasing tendency of PR over Δf , which implies more robustness of the LoRa system against interference. It corresponds to the fact that with increasing Δf , the spectral overlap decreases. Therefore it is necessary to increase the power of the interfering signal I to increase the side lobes of the spectrum to compensate mentioned reduction of the spectral overlap. Furthermore, according to eq. 4.1, the increase of I reduces the PR. This phenomenon is evident in fig. 5.2, where the measured spectra of Bluetooth and LoRa for SF = 5 and SF = 12 can be seen. The figure shows spectra of Bluetooth and LoRa signals at $\Delta f = 0$ and the Bluetooth signal at the maximum measured Δf_{max} . The displayed spectra respect the measured signal power levels. The displayed LoRa spectrum has a "special" character. This is caused by the bidirectional communication between the LoRa modules, where Tx module opens an Rx window after each sent packet, in which it does not transmit.

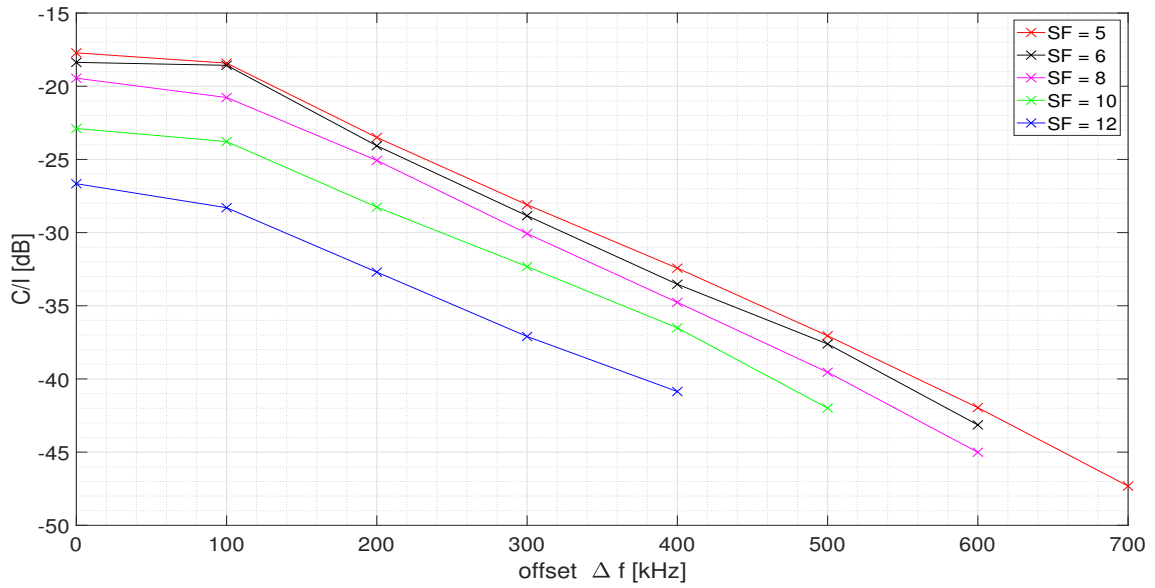

Fig. 5.1: LoRa BW200 C/I for various SF

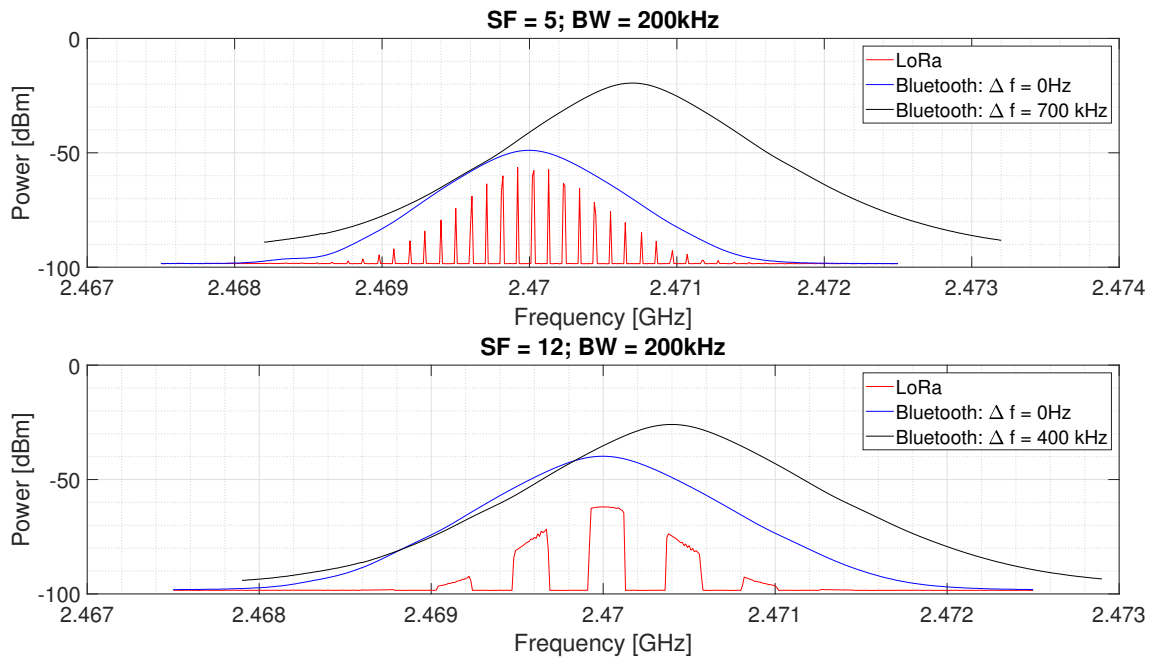

Fig. 5.2: Spectra of Bluetooth and LoRa signals at $\Delta f = 0$ and Δf_{max}

Tx power is measured with help of a spectrum analyzer, which has too short SWT (12s) in order to speed up the measurement. Therefore spectrum analyzer samples the signal, even when the Rx window is open and does not receive any signal. The difference in the spectrum for SF = 12 and SF = 5 is caused by differences between Tx and Rx window times. If a large SWT (hundreds of seconds) was set, the spectrum would become continuous.

5.2 LoRa: BW = 400 kHz

This measurement is similar to the previous one. In both cases, a combination of parameters, in which the LoRa has at least two times lower BW than Bluetooth. It can be understood as broadband interference caused by Bluetooth. Therefore LoRa behaves similarly for this and previous measurements. The measurement was performed for the same combination of parameters as in previous measurements except for the LoRa BW, which was changed to 400 kHz.

For the selected bandwidth 400 kHz, the maximum Δf_{max} 750 kHz was measured with a step Δf_{step} of 150 kHz. Since Δf_{step} is similar to the previous measurement, it is possible to compare graphs of both measurements. The following fig. 5.4 shows the dependencies of PR on Δf for SF = 5 and SF = 12 for both measurements (BW 200 and 400). And in fig. 5.3 all measured combinations for LoRa BW 400 are shown.

Fig. 5.4 shows that for CSSS the combination with BW 400 kHz is surprisingly more resistant against interference, which contradicts the theoretical assumptions, where the sensitivity of the Rx module should decrease with higher bandwidth. The behavior in INCS is also interesting, because after exceeding Δf approximately at 120 kHz for SF = 5 and 20 kHz for SF = 12, the combination with BW 200 seems to be more robust. From $\Delta f = 300$ kHz, the combination with BW = 200 kHz has a better PR compared to BW = 400 kHz by 3 dB for SF = 5 and 4 dB for SF = 12. Similarly, as in previous measurements, there is an overview of the measured spectra in fig. 5.5.

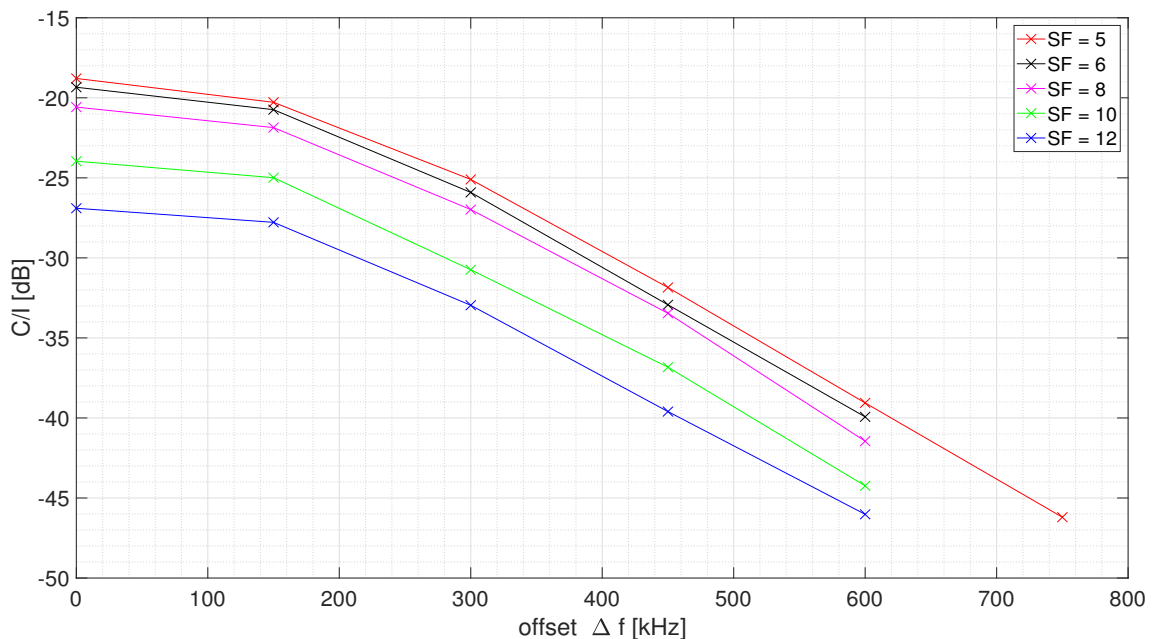

Fig. 5.3: LoRa BW400 C/I for various SF

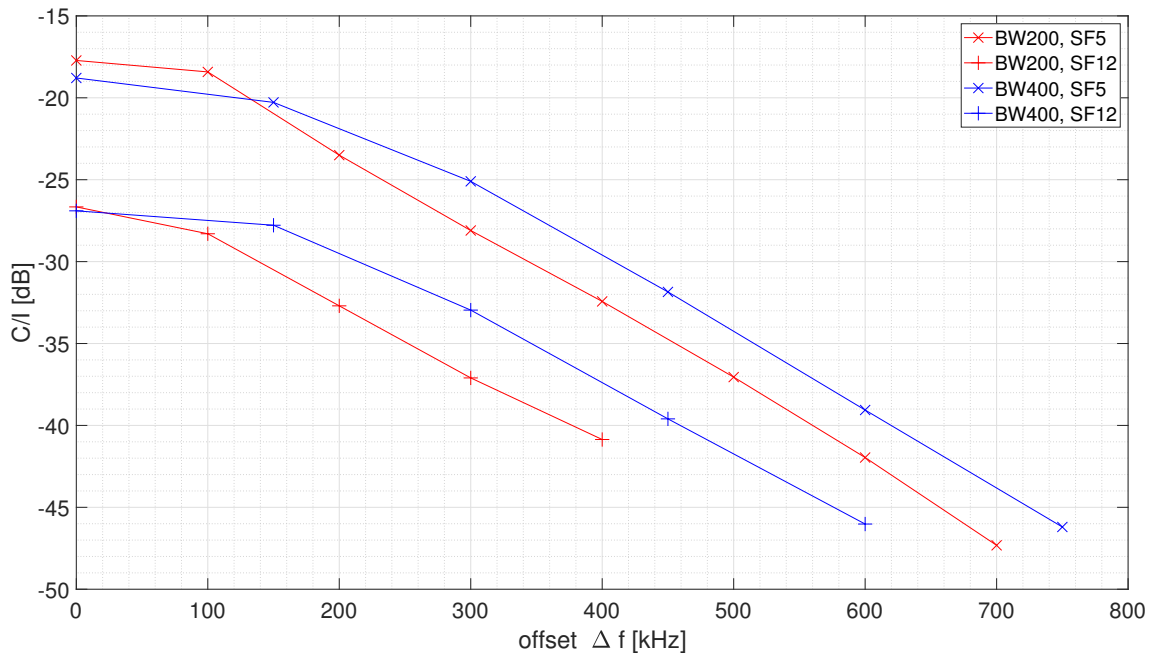

Fig. 5.4: Comparison of PR for LoRa BW200 and 400 for SF = 5 (red) and 12 (blue)

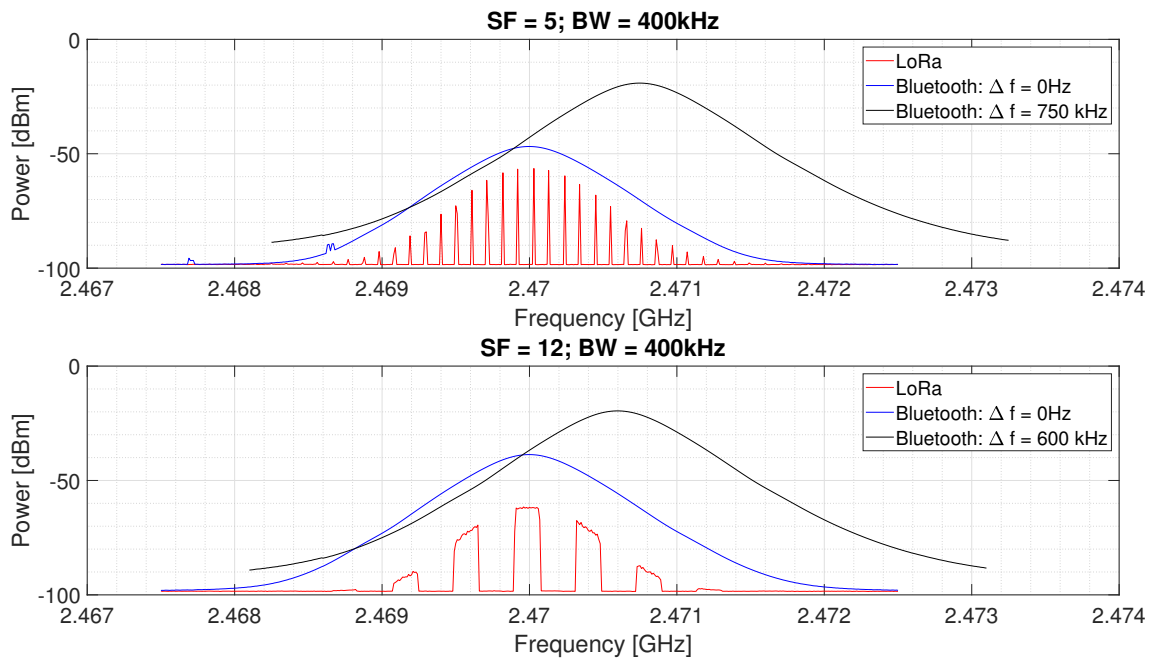

Fig. 5.5: Spectra of Bluetooth and LoRa signals at $\Delta f = 0$ and Δf_{max}

5.3 LoRa: BW = 800 kHz

This section is dedicated to the measurement of coexistence scenarios for the following combination of LoRa and Bluetooth PHY parameters.

Tab. 5.3: Parameters of LoRa and Bluetooth PHY

LoRa						Bluetooth		
modulation	BW [kHz]	SF	C [dBm]	CR	f_c [GHz]	modulation	BW [MHz]	Symbol Rate
LoRa (CSS)	800	5,6,8,10,12	-65	4/5	2.47	GFSK	1	1Msym/s

In this measurement, LoRa and Bluetooth have a comparable bandwidth. During the measurement, the maximum $\Delta f_{max} = 1$ MHz was reached with the step of 200 kHz. We can see that in this scenario, PR remains almost independent of Δf up to approximately 400 kHz. After exceeding this value, PR begins to decrease with a slope of approximately 9 dB/200 kHz.

In INCS, PR = -14.66 dB for SF = 5 and PR = -26.55 dB for SF = 12 were measured. As in previous measurements, SF does not significantly affect the shape of the dependencies and only affects their amplitude.

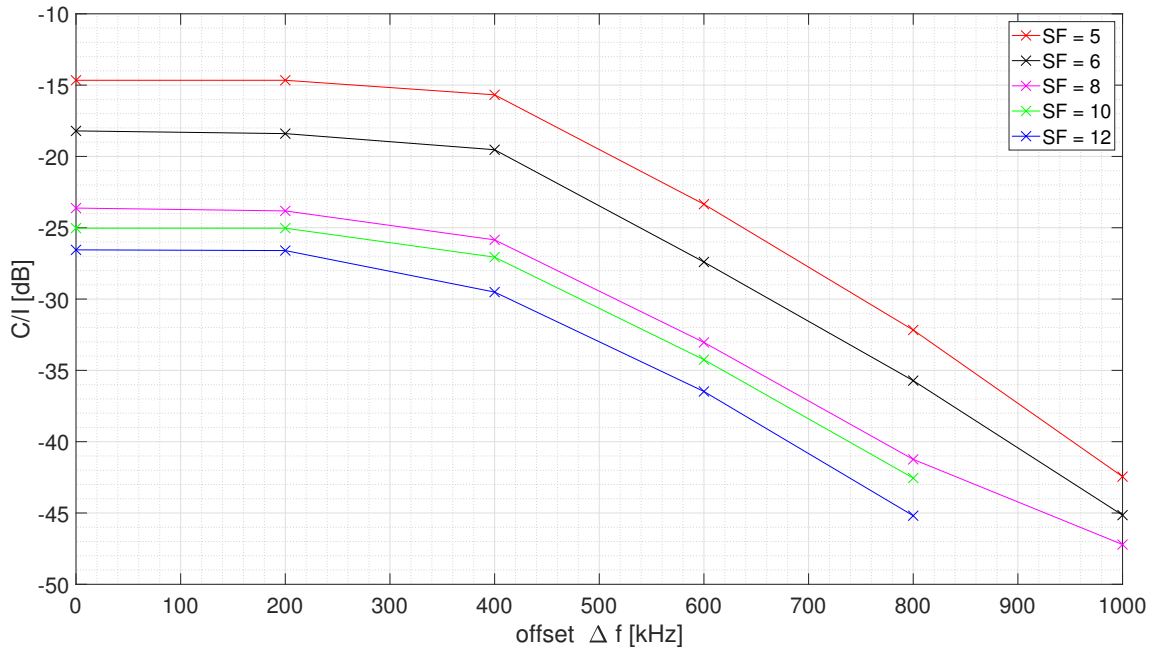

Fig. 5.6: LoRa BW800 C/I for various SF

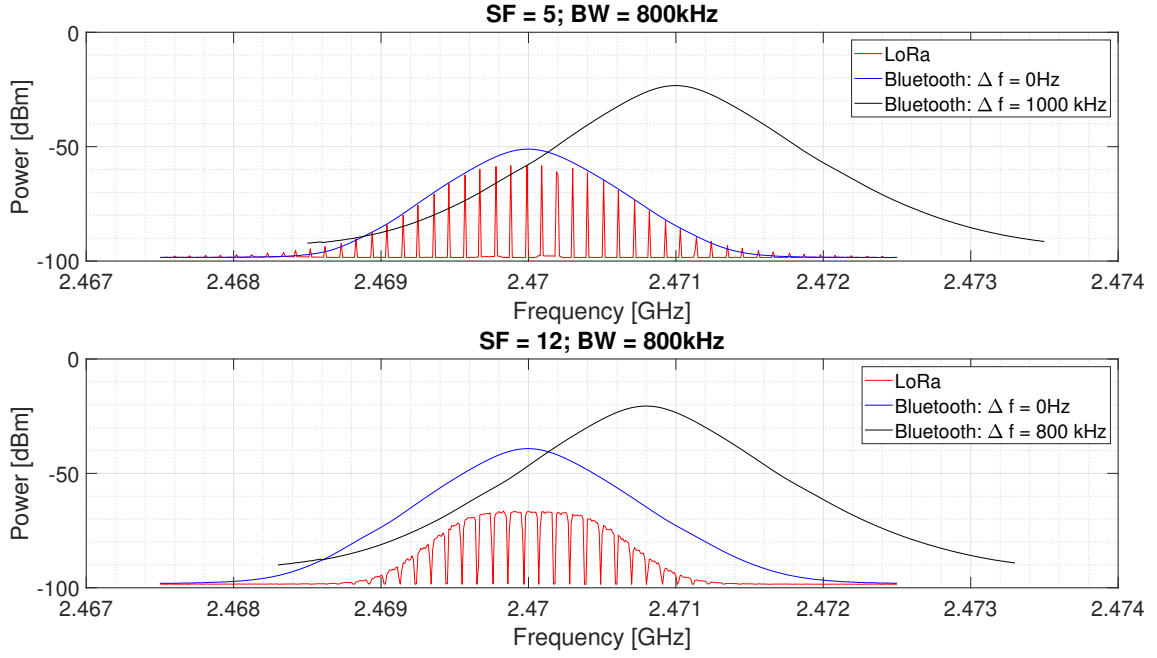

Fig. 5.7: Spectra of Bluetooth and LoRa signals at $\Delta f = 0$ and Δf_{max}

5.4 LoRa: BW = 1600 kHz

The parameters for the PHY layer of LoRa and Bluetooth signals were set according to table 5.4. In this measurement, the lower Tx power level of the LoRa module was set than in the previous measurements in order to reach a higher maximum Δf_{max} . By reducing the Tx power level, the shape of the Bluetooth signal will also change slightly, because the side lobes are reduced as well. It leads to a minor change in the measured PR. However, before the measurement, the reference PR values for several SFs were also measured at LoRa output power of -65 dBm. The difference between the results is smaller than 0.5 dB, so the effect of Tx power level on PR can be neglected.

Tab. 5.4: Parameters of LoRa and Bluetooth PHY

LoRa						Bluetooth		
modulation	BW [kHz]	SF	C [dBm]	CR	f_c [GHz]	modulation	BW [MHz]	Symbol Rate
LoRa (CSS)	1600	5,6,8,10,12	-75	4/5	2.47	GFSK	1	1Msym/s

Compared to Bluetooth signal, LoRa has larger BW, which can be observed in fig. 5.9. Therefore, the interference caused by the Bluetooth signal can be understood as narrowband interference. The maximum $\Delta f_{max} = 2400 \text{ kHz}$ was achieved with a step of 400 kHz. Therefore CSSS, INCS and ACSS were achieved.

If we look at the shape of measured dependencies, PR remains almost constant up to about $\Delta f = 400$ kHz. Between $\Delta f = 400$ kHz and $\Delta f = 1600$ kHz PR decreases approximately by 18 dB. Therefore, the immunity of the LoRa system against Bluetooth interference increases approximately 63 times. From $\Delta f = 1600$ kHz the PR decrease slows down, and the immunity of the LoRa system increases only slightly.

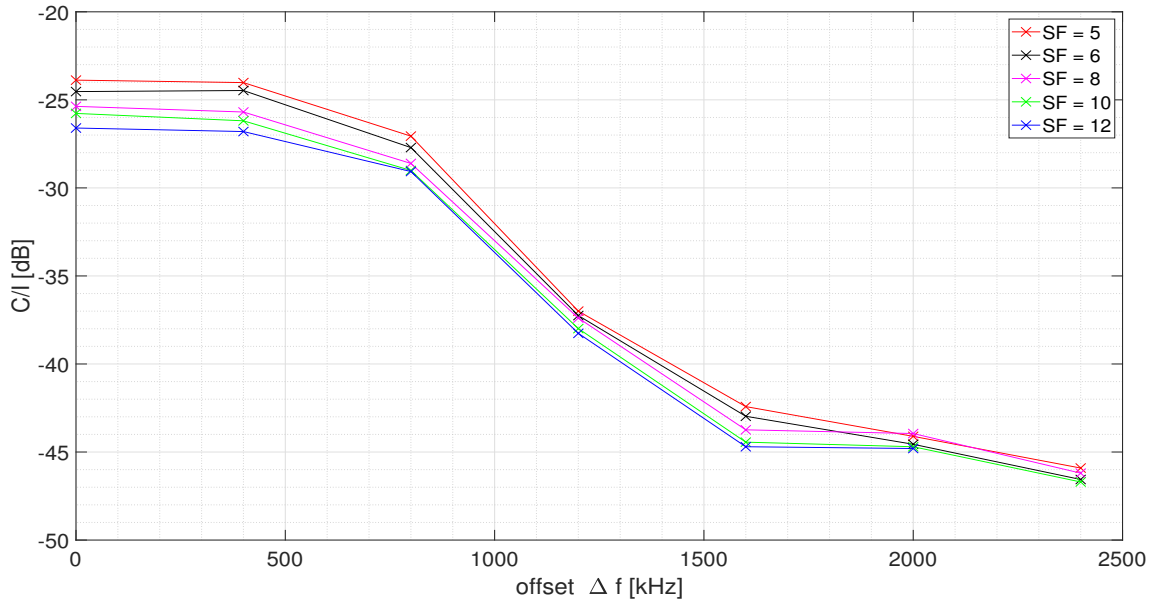

Fig. 5.8: LoRa BW1600 C/I for various SF

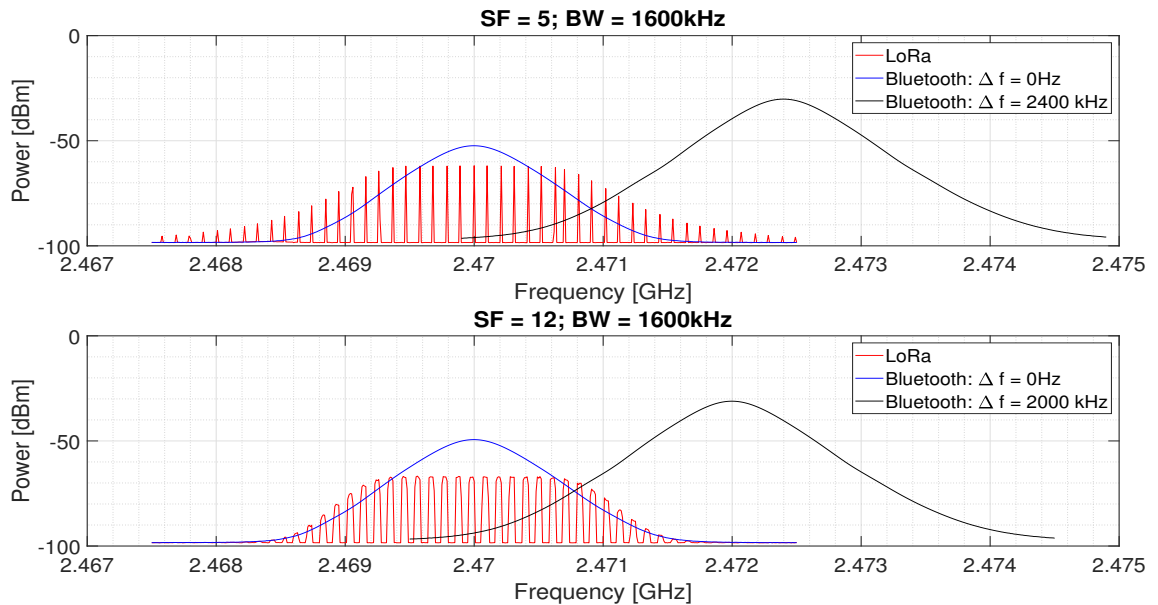

Fig. 5.9: Spectra of Bluetooth and LoRa signals at $\Delta f = 0$ and Δf_{max}

5.5 Summary of the results

This section is dedicated to the main differences between the coexistence scenarios presented in sections 5.1 to 5.4.

In Figs. 5.1, 5.3, 5.6 and 5.8, we can see that in the CSSS, the distribution of SFs is not uniform. For the BW 200 kHz and 400 kHz, the effect of SF on PR has a growing trend. In other words, the PR differences $\Delta PR = 1.7 \text{ dB}$ between SF = 5 and SF 8 and $\Delta PR = 6.2 \text{ dB}$ between SF = 8 and SF = 12 were measured respectively. On the other hand, the effect of SF on PR for LoRa BW 800 has a decreasing trend. For BW 1600, the effect of SF on the measured PR is less relevant than for other BWs, where the PR difference between SF = 5 and SF = 12 is only 2.72 dB. In the following table, in the column ΔPR , the difference of PR (ΔPR) related to the reference value of SF = 5 for all BWs is shown. In the last line (SF = 12 - SF = 5) we can see the maximum change that can be achieved by changing SF.

Tab. 5.5: Comparison of the SFs effect on PR for individual LoRa BWs

	$\Delta PR[dB]$			
ΔSF	BW 200	BW 400	BW 800	BW 1600
SF6 - SF5	-0.65	-0.55	-3.55	-0.65
SF8 - SF5	-1.73	-1.79	-8.96	-1.49
SF10 - SF5	-5.17	-5.17	-10.37	-1.89
SF12 - SF5	-8.94	-8.11	-11.89	-2.72

In order to compare individual results with each other, SF = 5 and SF = 12 for all BWs are shown in Figure 5.10. These values of SF = 5 and SF = 12 were chosen because they represent limit values, and the results for the other SFs lie between these extremes. For Fig. 5.10, fixed values of the X and Y axes are chosen to highlight the differences between measured combinations. If we compare the PR for individual BWs for SF = 5 in CSSS, we can see that the highest immunity against interference is achieved for BW = 1600 kHz, where the PR = -23.88 dB was measured. On the other hand, LoRa is the most vulnerable to Bluetooth for the BW = 800 kHz, where both systems have similar BWs.

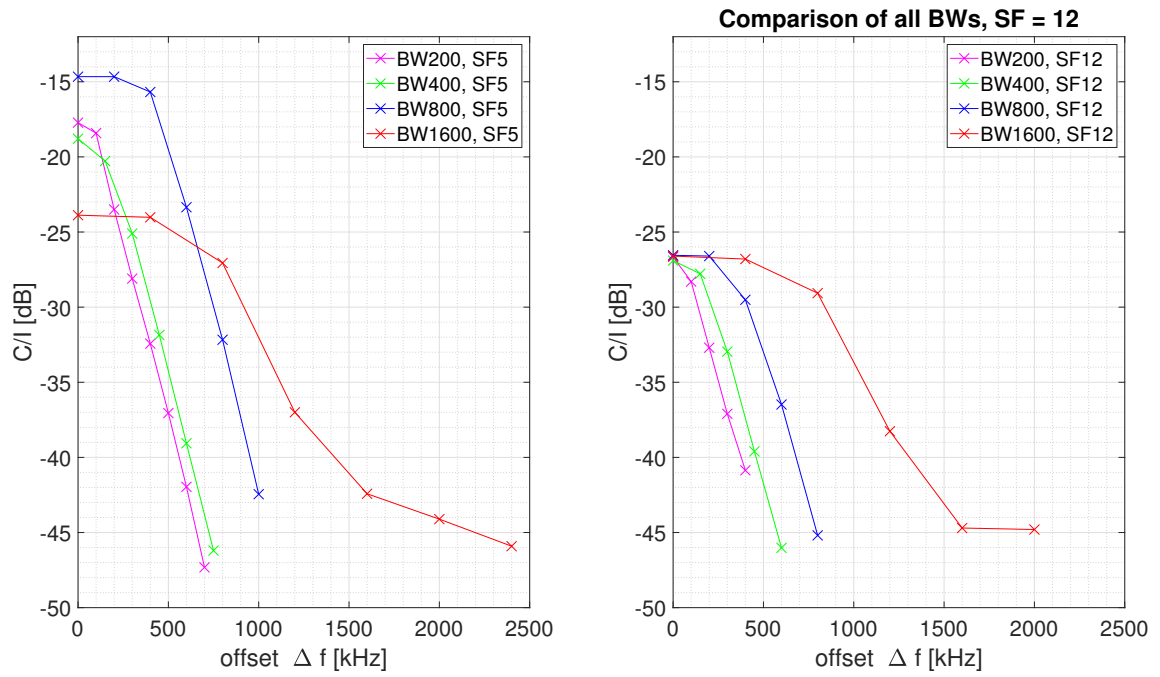

Fig. 5.10: Comparison of all BWs for SF = 5 and SF = 12

In the CSSS for SF = 12, PR around 26.7 dB was measured for all BWs. Fig. 5.10 also shows the effect of Δf on PR. In general, the narrower the LoRa BW, the faster the PR decreases over Δf .

5.6 Comparison with related works

Compared to other studies, a comparison of the results with application note: Bluetooth Immunity of LoRa at 2.4 GHz from SEMTECH [17] could probably be the most relevant. The study uses a very similar methodology and evaluation of C/I at PER = 10% as in our case. The main difference is that the SEMTECH adds the measurement of coexistence between Bluetooth EDR ($\pi/4$ -DQPSK and 8-DPSK modulation). Furthermore, SEMTECH extends the measurement of Out-Band coexistence scenarios, which we did not achieve due to technical possibilities. SEMTECH includes measurements only for combinations of LoRa PHY (SF = 6 and 12 and BW = 200kHz and 1600kHz). In both theses, SF, BW and Δf a similar effect on the immunity of the LoRa system to Bluetooth interference can be observed.

There are works dealing with the coexistence between LoRa and Wi-Fi [4, 18], which adds measurements of the immunity of LoRa against OFDM (BPSK and 64QAM) modulations. The results show that, as in our work, the immunity of the LoRa system against Wi-Fi increases with increasing SF and Δf . However, LoRa immunity against Wi-Fi behaves differently when the LoRa BW changes. The main difference is that, while increasing the LoRa BW, the shape of the measured dependencies does not change significantly and only the immunity of LoRa against Wi-Fi decreases. This is probably caused because Wi-Fi has significantly higher bandwidth than LoRa even at the highest LoRa bandwidth (1600kHz), therefore interference in all cases has broadband character. On the other hand, the coexistence between LoRa and Bluetooth changes from broadband to narrowband interference character according to the LoRa BW, and the results caused by changing LoRa BW cannot be compared.

Conclusion

The bachelor thesis aimed to define and measure coexistence scenarios between LoRa and Bluetooth in the ISM band 2.4 GHz. The theoretical part describes the PHY layers of LoRa and Bluetooth systems. In order to experimentally measure the immunity of the LoRa system to Bluetooth in defined coexistence scenarios, a measurement testbed was designed. The results of an experimental part are presented in the graphical form of dependencies of PR on offset. The measured results are commented in detail in the experimental part of the thesis and then compared with existing works on similar topics. The measured results show that SF, BW, and delta f can affect the LoRa system's immunity. Finally, a laboratory was created (written in the Czech language), which will be used for educational purposes for BPC-MKO course taught at BUT university.

The challenging part of the the thesis was the workflow with the WiMOD LR studio software, which was used to set up LoRa PHY and measure PER. This software does not allow measuring PER during one-directional communication between RX and TX LoRa modules. Another disadvantage of this software is that it only measures PER (does not support BER measurements), which in combination with the transmission speed of the LoRa system significantly slows down the measurement. This problem is discussed in more detail in the experimental part.

This thesis bases the ground for future research of coexistence between LoRa and Bluetooth in the 2.4 GHz band. The LoRa system allows setting different combinations of PHY (e.g. FLRC and GFSK modulation), which were not measured in this work due to time and technical reasons. Also, other types of Bluetooth than BR (e.g. EDR and BLE) could be used. Furthermore, only Co-Channel, In-band and adjacent coexistence scenarios were achieved. The Out-Band scenario was not achieved due to the limited power of the R&S SMU 200A generator, which was used to generate the Bluetooth signal. Due to the time complexity, it would be appropriate to automate the measurement.

Bibliography

- [1] Mašek Pavel, Communication Technologies and Protocols for (Industrial) Internet of Things. [online]. 22.2.2021 [cit.4..2021]. Available at: <https://moodle.vutbr.cz/pluginfile.php/340056/mod_resource/content/1/BPC-IOT_L03_Final.pdf>
- [2] CISCO, Cisco Annual Internet Report (2018–2023) White Paper. [online]. 9.3.2020 [cit.4..2021]. Available at: <<https://www.cisco.com/c/en/us/solutions/collateral/executive-perspectives/annual-internet-report/white-paper-c11-741490.html>>
- [3] Margaret Rouse, Internet of things(IoT). [online]. February 2020 [cit.17.10.2020]. Available at: <<https://internetofthingsagenda.techtarget.com/definition/Internet-of-Things-IoT>>
- [4] Kauciarik Filip, Koexistence systémů LoRa a Wi-Fi v RF pásmu 2.4 GHz. [online]. 16.6.2020 [cit.17.10.2020]. Available at: <https://www.vutbr.cz/studenti/zav-prace/detail/126128>.
- [5] Caroline Hayes, Managing power in the IoT with cellular LPWAN technology [online]. 9.2.2019 [cit.17.10.2020]. Available at: <[//www.electronicsspecifier.com/news/analysis/managing-power-in-the-iot-with-cellular-lpwan-technology](https://www.electronicsspecifier.com/news/analysis/managing-power-in-the-iot-with-cellular-lpwan-technology)>.
- [6] Ofcom, Frequency bands designated for Industrial, Scientific and Medical use (ISM). [online]. June 2017 [cit.17.10.2020]. Available at: <https://www.ofcom.org.uk/__data/assets/pdf_file/0022/103297/fat-ism-frequencies.pdf>
- [7] David Evans, LoRaWAN Network Server – Integrated or Cloud-hosted? [online]. 22.10.2019 [cit.17.10.2020]. Available at: <<https://www.rs-online.com/designspark/lorawan-network-server-integrated-or-cloud-hosted-1>>.
- [8] Semtech, What are LoRa® and LoRaWAN® ? [online]. 11.2.2020 [cit.17.10.2020]. Available at: <<https://lora-developers.semtech.com/library/tech-papers-and-guides/lora-and-lorawan/>>.
- [9] The Things Industries, LoRaWAN Frequency Plans and Regulations by Country. [online]. 2020 [cit.17.10.2020]. Available at: <<https://www.thethingsnetwork.org/docs/lorawan/frequencies-by-country.html>>.

- [10] Semtech, LoRa Modulation Basics [online]. 2.5.2015 [cit. 19.10.2020]. Available at: <<https://semtech.my.salesforce.com/sfc/p/#E0000000JelG/a/2R00000010Ju/xvKUc5w9yjG1q5Pb2IIkpolW54YYqGb.fr0Z7HQBcRc>>.
- [11] Vitor Manuel Fialho, Fernando Azevedo, Wireless Communication Based on Chirp Signals for LoRa IoT Devices [online]. december 2018 [cit. 19.10.2020]. Available at: <https://www.researchgate.net/publication/329913331_Wireless_Communication_Based_on_Chirp_Signals_for_LoRa_IoT_Devices>.
- [12] Semtech, Semtech SX1280. [online]. 2020 [cit. 19.10.2020]. Available at: <<https://www.semtech.com/products/wireless-rf/24-ghz-transceivers/sx1280>>
- [13] Augustin, Aloys and Yi, Jiazi and Clausen, Thomas Heide and Townsley, William, A Study of LoRa: Long Range & Low Power Networks for the Internet of Things [online]. 2016 [cit. 28.10.2020]. Available at: <https://www.researchgate.net/publication/307965130_A_Study_of_LoRa_Long_Range_Low_Power_Networks_for_the_Internet_of_Things>.
- [14] IEEE 802.15.1-2005, Local and metropolitan area networks– Specific requirements– Part 15.1a: Wireless Medium Access Control (MAC) and Physical Layer (PHY) specifications for Wireless Personal Area Networks (WPAN). [online]. 07, May, 2018 [cit. 17.11.2020]. Available at: <https://standards.ieee.org/standard/802_15_1-2005.html>.
- [15] Kashif Munir Virk, Design of an integrated GFSK demodulator for a bluetooth receiver [online]. 2019 [cit. 9.11.2020]. Available at: <<http://www2.imm.dtu.dk/pubdb/edoc/imm5479.pdf>>.
- [16] Rohde & Schwarz, R&S SMBVB-K60/-K117 Bluetooth Enhanced Data Rate, Bluetooth 5.x [online]. 7.5.2018 [cit. 17.11.2020]. Available at: <https://scdn.rohde-schwarz.com/ur/pws/dl_downloads/pdm/cl_manuals/user_manual/1178_8120_01/SMBVB_Bluetooth_EDR_UserManual_en_04.pdf>.
- [17] Semtech, Bluetooth Immunity of LoRa at 2.4 GHz [online]. April 2018 [cit. 28.10.2020]. Available at: <<https://semtech.my.salesforce.com/sfc/p/#E0000000JelG/a/2R000000HSNz/HeroVQVf0kV2KaLGS7BiPaFWWoCXVsrP3rFKf9hs6JQ>>.

- [18] Polák Ladislav, Miloš Jiří, Performance analysis of LoRa in the 2.4 GHz ISM band: coexistence issues with Wi-Fi [online]. July 2020 [cit. 20.02.2021]. Available at: <https://www.researchgate.net/publication/339714225_Performance_analysis_of_LoRa_in_the_24_GHz_ISM_band_coexistence_issues_with_Wi-Fi>.

List of symbols, quantities and abbreviations

ACCS	Adjacent Channel Coexistence scenario
BFSK	Binary Frequency Shift Keying
BR	Bluetooth Basic Rate
BT	Roll of Factor
BW	Bandwidth
CPFSK	Continuous Phase Frequency Shift Keying
CR	Coding Rate
CRC	Cyclic Redundancy Check
CSS	Chirp Spread Spectrum
CSSS	Co-Channel Coexistence Scenario
FEC	Forward Error Correction
FHSS	Frequency Hopping Spread Spectrum
FM	Frequency Modulation
GB	Guard Band
GFSK	Gaussian Shift Keying Modulation
GUI	Graphical User Interface
IEEE	Institute of Electrical and Electronics Engineers
INCS	In-BandCoexistence Scenario
IoT	Internet Of Things
ISM	Industrial Scientific and Medicin
LoRa	Long Range
LoRaWAN	Long Range Wide Area Network
LPWA	Low Power Wide Area
LPWAN	Low Power Area Network

OBCS	Out-Band Coexistence Scenario
PAN	Personal Area Network
PER	Packet Error Ratio
PHY	Physical Layer
PR	Protection Ratio
RF	Radio Frequency
RSSI	Received Signal Strength Indicator
SF	Spreading Factor
WPAN	Wireless Personal Area Network

Zadání

1. Seznamte se obsluhou vektorového signálového generátoru SMU 200A a signálového analyzátoru FSP firmy Rohde & Schwarz (dále R&S)
2. Vygenerujte LoRa signál definovaných parametrů na SK-iM282A LoRa modulech a pomocí WIMoD LR Studia proveďte test rádiového spojení
3. Pomocí generátoru R&S SMU 200A vygenerujte Bluetooth signál
4. Změřte koexistenční scénáře mezi LoRa a Bluetooth systémy v ISM pásmu 2,4 GHz
5. Vypracujte přehlednou zprávu o měření

Teoretický úvod

Laboratorní úloha se zabývá měřením koexistenčních scénářů mezi Long Range (LoRa) a Bluetooth v bezlicenčním Industrial Scientific and Medicin (ISM) pásmu 2,4 GHz .

LoRa

LoRa je členem rodiny Low Power Wide Area Network (LPWAN). Tato síť je určena pro přenos malého množství dat (0,3 kbps až 50 kbps) na velké vzdálenosti (desítky kilometrů), při využití co nejmenšího výkonu (Obr. 1). Díky těmto vlastnostem je technologie LoRa vhodná pro bateriově napájená IoT zařízení.

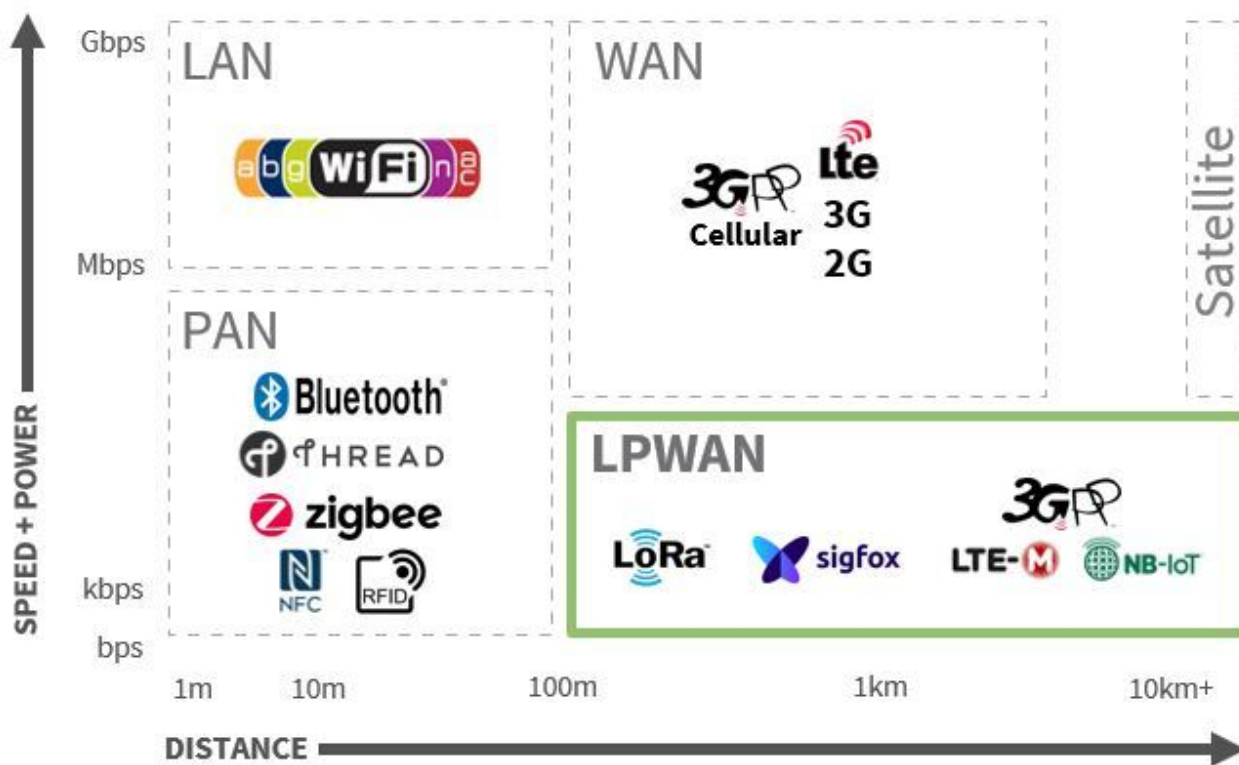

Obrázek 1: zařazení sítí WPAN a LPWAN

LoRa využívá modulaci založenou na Chirp Spread Spectrum (CSS). Tato modulace využívá tzv. chirp jako nosný signál a zpráva je pak obsažena v jednotlivých frekvenčních skocích (Obr. 2). Takto modulovaný signál je odolný proti Dopplerově efektu, vícecestnému šíření, umožňuje lokalizaci a je všeobecně velmi odolný vůči interferencím.

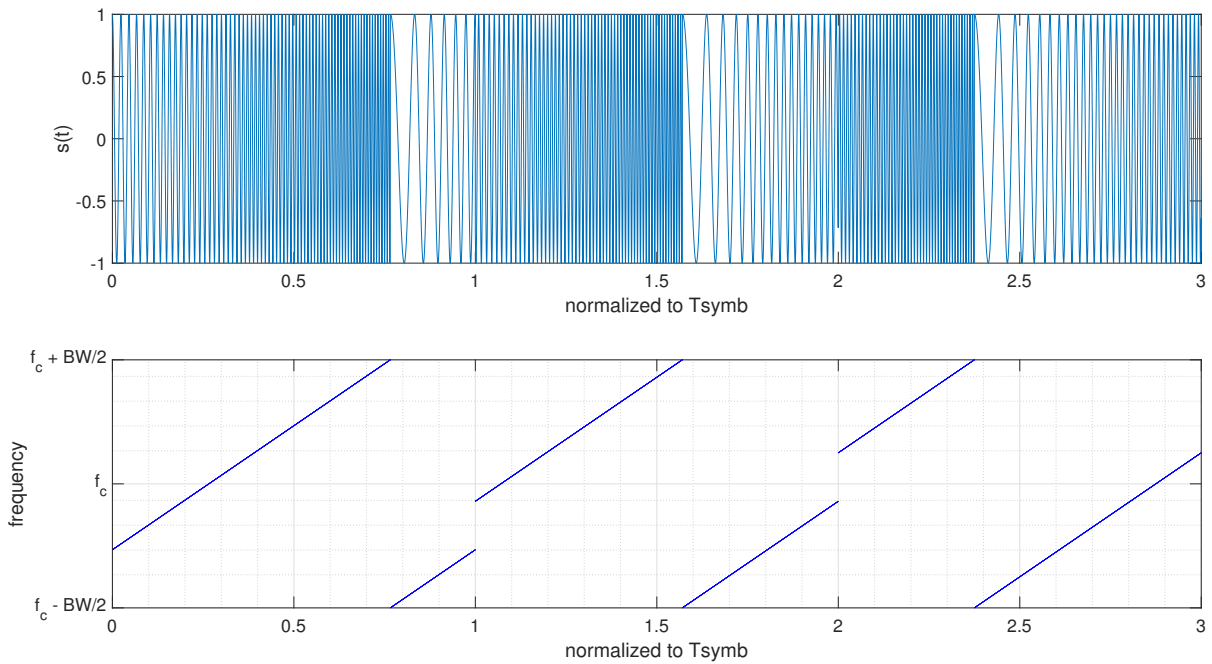

Obrázek 2: CSS modulace $s(t)$ nahoře a $f(t)$ dole

Na rozdíl od tradičního sub-GHz pásma, pro které byla LoRa prvotně navržena, nemá v 2,4 GHz pásmu požadavky na duty cycle. Dále nabízí rozšířenou volbu Spreading Factorů (5 až 12) a nové šířky pásma BW (200 kHz, 400 kHz, 800 kHz, 1600 kHz). Právě volba SF a (BW) ovlivňuje odolnost LoRa systémů vůči rušení. Obecně platí, že při vyšším SF je přijímač schopen dekodovat více zašumělý signál, kde pro $SF = 5$ lze dekodovat signál o SNR přibližně -3 dB a pro $SF = 12$ může SNR nabývat hodnot kolem -20 dB. Zvýšení hodnoty SF sebou však nese i nevýhody v podobě snížení datového toku. Naopak zvyšováním šířky pásma je možné dosáhnout přenosových rychlostí za cenu snížené citlivosti přijímače.

Bluetooth

Bluetooth je provozován v bezlicenčním 2,4 GHz pásmu a je členem (Wireless Personal Area Network) WPAN, která je definována pracovní skupinou IEEE 802.15.1. Tato síť je určena pro přenos dat na krátké vzdálenosti (desítky metrů) s vyšším datovým tokem (jednotky až desítky Mb/s) než je tomu u LPWAN. Další specifickou vlastností WPAN je, že pro svou funkci nepotřebuje téměř žádnou infrastrukturu a lze přenášet data přímo mezi koncovými zařízeními.

V současné době existuje několik druhů Bluetooth jako např. Low Energy (BLE), Enhance Data Rate (EDR), Basic Rate (BR) a další. V této laboratorní úloze je uvažována právě varianta Bluetooth Basic Rate, který ke své funkci využívá GFSK modulaci se šířkou pásma 1 MHz, Indexem modulace (0,28 až 0,35) a roll of faktorem Gaussova filtru ($BT = 0,5$). Při reálném přenosu se uplatňuje i Frequency Hopping Spread Spectrum (FHSS), který mění nosnou frekvenci pseudonáhodným způsobem, tak aby se předešlo případným interferencím. V této laboratorní úloze bude mít generovaný Bluetooth neměnnou nosnou frekvenci po celou dobu přenosu a FHSS se tak neuplatní.

Koexistenční scénáře

Jak již bylo zmíněno výše, obě technologie pracují v bezlicenčním 2,4 GHz ISM pásmu a můžou tak nastat scénáře, ve kterých budou obě technologie současně využívat stejné frekvenční spektrum. Na obrázku (Obr. 3) můžeme vidět symbolické rozložení jednotlivých LoRa (oranžově) a Bluetooth (modře) kanálů. Důležitým parametrem při popisu koexistenčních scénářů je frekvenční offset Δ_f , který popisuje frekvenční rozdíl mezi nosnými frekvencemi f_c jednotlivých systémů. Právě v závislosti na Δ_f lze vzájemnou koexistenci LoRa a Bluetooth systémů rozdělit na čtyři scénáře (viz. Obr. 4). V Co-Channel Coexistence Scenario (CSSS) oba systémy sdílejí stejnou střední frekvenci f_c a dochází tak k největšímu rušení v důsledku vysokého překryvu spekter. Se zvyšujícím se offsetem Δ_f přecházíme postupně přes In-Band Coexistence Scenario (INCS) do Adjacent Channel Coexistence scenario (ACCS). V těchto scénářích dochází k překryvu spekter v důsledku nenulových šířek pásma obou systémů a postranních laloků spekter. V Out-Band Coexistence Scenario (OBCS) dochází buď k minimálnímu a nebo žádnému překryvu spekter. Pro OBCS je důležitým parametrem Guard Band (GB), který představuje nevyužitou část spektra alokovanou za účelem předcházení interferencí.

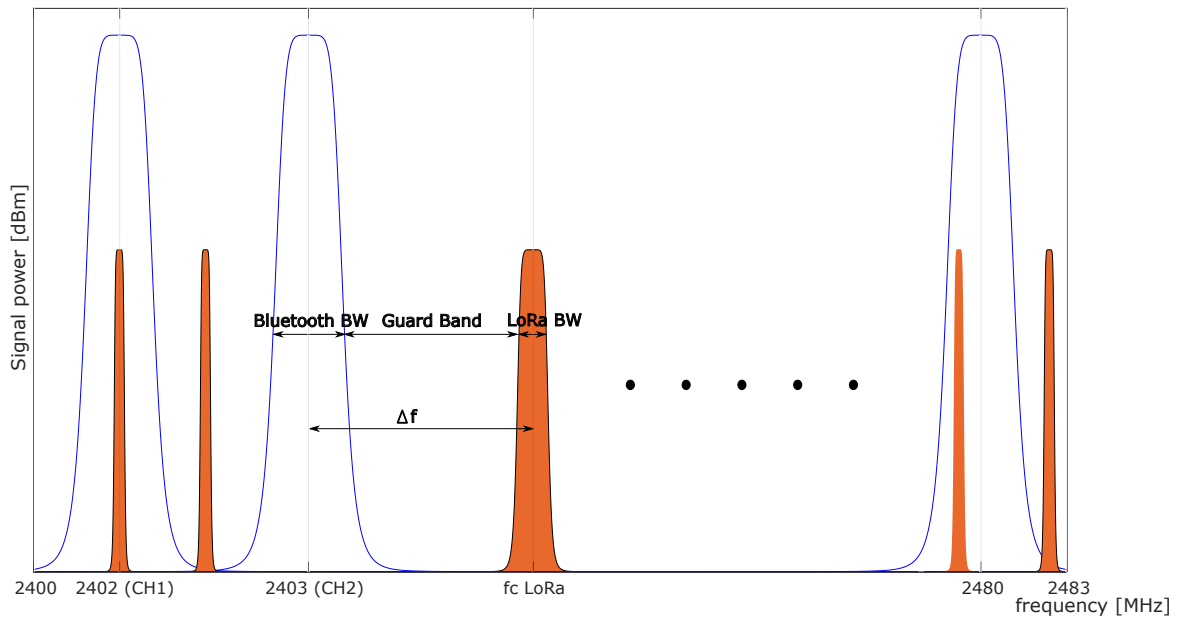

Obrázek 3: Koexistence mezi LoRa a Bluetooth v 2,4GHz ISM pásmu

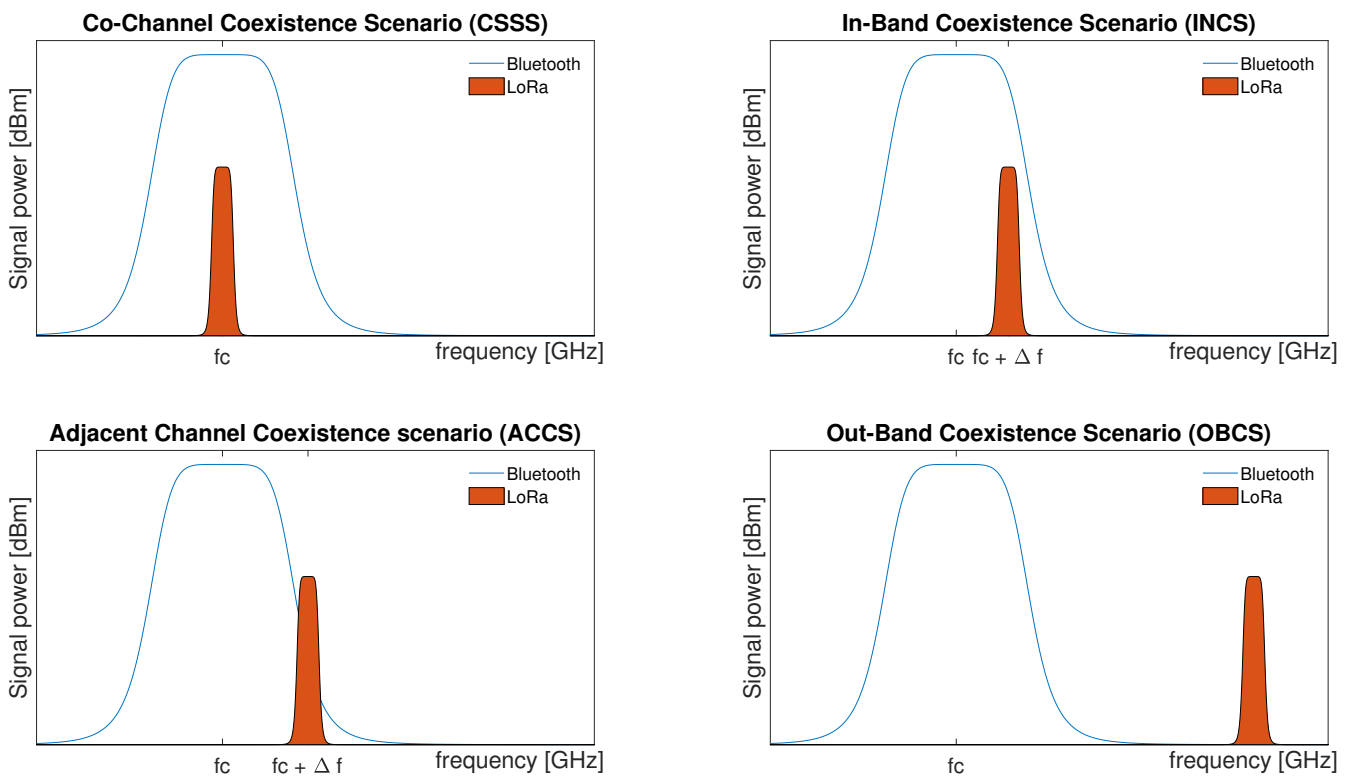

Obrázek 4: Typy koexistenčních scénářů

C/I Ratio

Jedním ze způsobů, jak definovat odolnost systému vůči rušení jiným systémem, je změřit ochranný poměr tzv. Protection Ratio (PR).

$$PR[dB] = C[dBm] - I[dBm], \quad (1)$$

kde C značí výkonovou úroveň signálu rušeného systému (v našem případě LoRa) a I rušivého signálu (Bluetooth) při Packet Error Ratio (PER) = 10%. PER označuje míru chybně přijatých paketů rušeného (LoRa) signálu a 10% je stanovená mezní hodnota do které se přenos považuje za spolehlivý. Abychom však získali širší představu o odolnosti systému je vhodné vycházet z závislosti PR na Δ_f .

Postup měření

Za účelem měření závislosti $PR = F(\Delta_f)$ byl navržen měřicí testbed. Pro generování a zpracování LoRa signálu jsou využity dva vývojové kity (Rx a Tx) SK-IM282A ovládané přes UART pomocí desktopové aplikace WiMOD LR Studio, která umožňuje měřit PER, SNR a nastavovat parametry fyzické vrstvy LoRa modulů. Generování Bluetooth signálů probíhá pomocí vektorového signálového generátoru R&S SMU 200A. Oba signály jsou pak přivedeny na Wilkinsonův slučovač. Výstup slučovače je přiveden na R&S signálový analyzátor FSP, kde probíhá měření výkonu spekter signálů, a na Rx LoRa modul. Vzhledem k šetrnosti k vektorovému signálovému generátoru R&S SMU 200A je vhodné nepřekračovat generovanou úroveň signálu nad -5 dBm! Z tohoto důvodu je za Tx LoRa modul přiřazen attenuator, aby se snížila výkonová úroveň LoRa signálu.

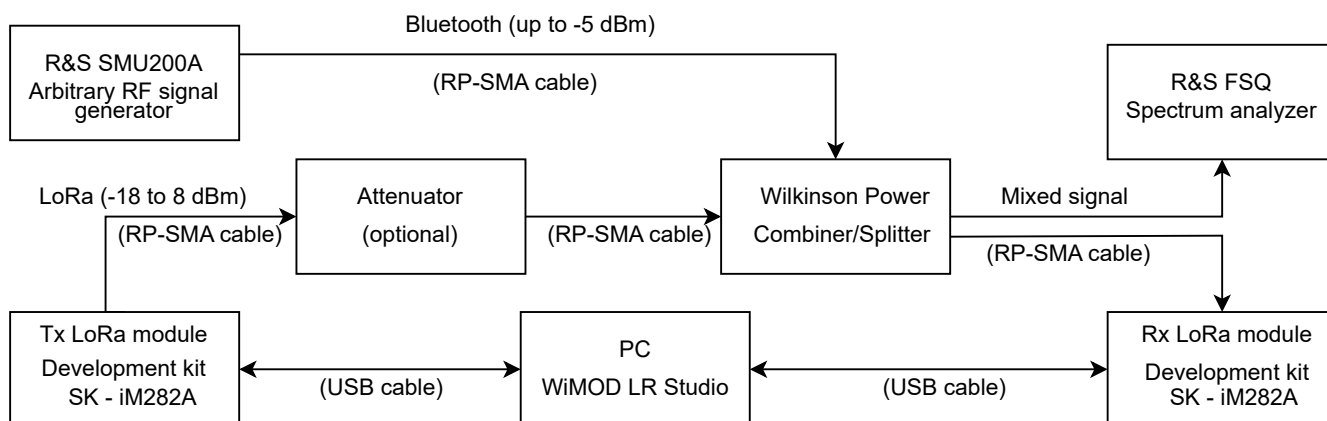

Obrázek 5: Měřicí testbed

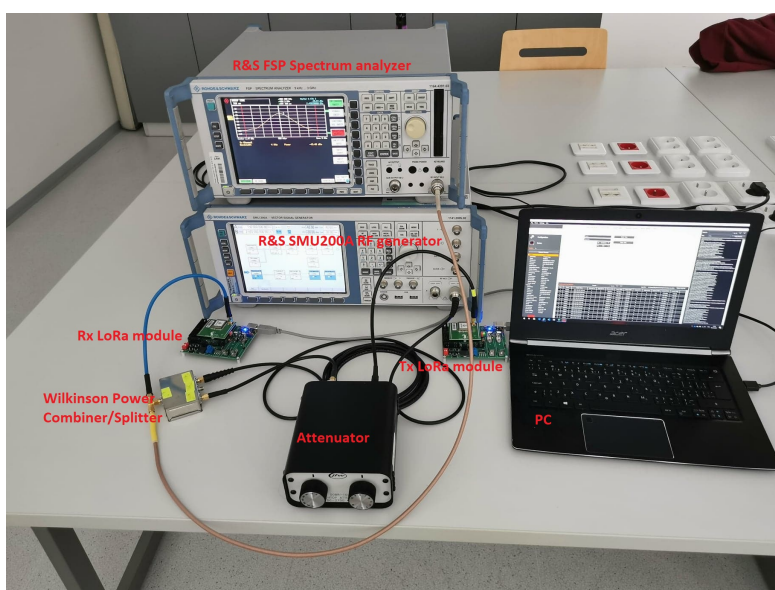

Obrázek 6: Reálné zapojení měřicího testbedu

1. Zapojte zařízení podle schématu na obrázku 5
2. Pomocí WiMoD LR studia (Configuration menu → Radio configuration) nastavte pro oba moduly (Rx a Tx) následující parametry. Mezi moduly se lze přepínat kliknutím do levého vertikálního navbaru na jakýkoliv parametr požadovaného zařízení. Před přepnutím na jiný modul, nezapomeňte nastavení potvrdit a nahrát do modulů stiskem tlačítka "Write Settings to Device" (pod tímto tlačítkem zaškrtněte "store in non-volatile memory"). Pokud nastavení do zařízení nenahrajete neuloží se ani v softwaru a budete muset nastavení zopakovat!

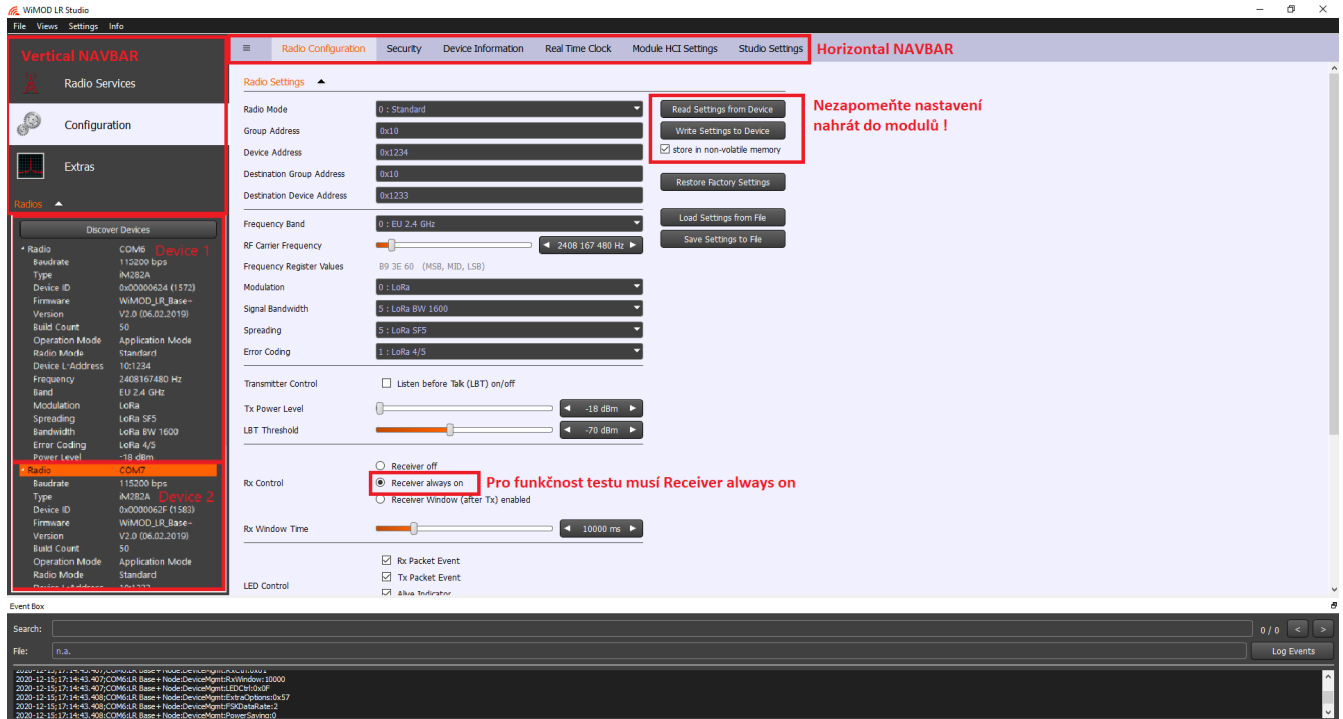

Obrázek 7: WiMoD LR studio: Configuration

Nastavení Parametrů pro Tx a Rx modul ve WiMOD LR studiu:

- a) Radio Mode: Standard
- b) Group Address: 0x10
- c) Device Address: Tato adresa slouží k identifikaci zařízení (podobně jako IP adresa u TCP/IP), zde nastavte libovolnou adresu rozdílnou pro RX a TX modul. Pro lepší orientaci je doporučeno zvolit poslední 4 čísla ze štítku na LoRa modulech
- d) Destination Group Address: 0x10
- e) Destination Device Address: Tato adresa určuje kam (komu) bude zpráva odesílána. Pro TX modul zvolte Device Address RX modulu a obráceně.
- f) **Frequency Band: EU 2,4 GHz**
- g) RF Carrier Frequency: Libovolná, doporučuje se volit celočíselné frekvence pro přehlednější odečítání (např. 2,47 GHz)
- h) Modulation: LoRa
- i) **Bw: 400 kHz**
- j) **SF: měření se bude opakovat pro tři SF (SF5, SF8 a SF12)**
- k) Error Coding : 4/5
- l) **Tx Power Level: nejnižší možný (- 18 dBm)**
- m) Rx Control: pro funkčnost následně prováděného testu je nutné zvolit Rx always on, tato možnost nastaví zařízení do módu podobného třídě C

n) Rx Window Time 4000 ms

o) Nezapomeňte nastavení potvrdit a nahrát do modulů stiskem tlačítka Write Settings to Device (pod tímto tlačítkem zaškrtněte "store in non-volatile memory")

3. Pomocí WiMoD LR studia (Radio Services menu → Radio Link Test) proveděte nastavení testu. V této záložce je automatické provedení testu, kde se výsledky testu zobrazují v pravé části programu v sekci Link Status (downlink pro směr z TX do RX). V dolní části programu je zobrazen časový průběh hodnot RSSI, kde označení peer odpovídá RX modulu a local odpovídá Tx modulu.

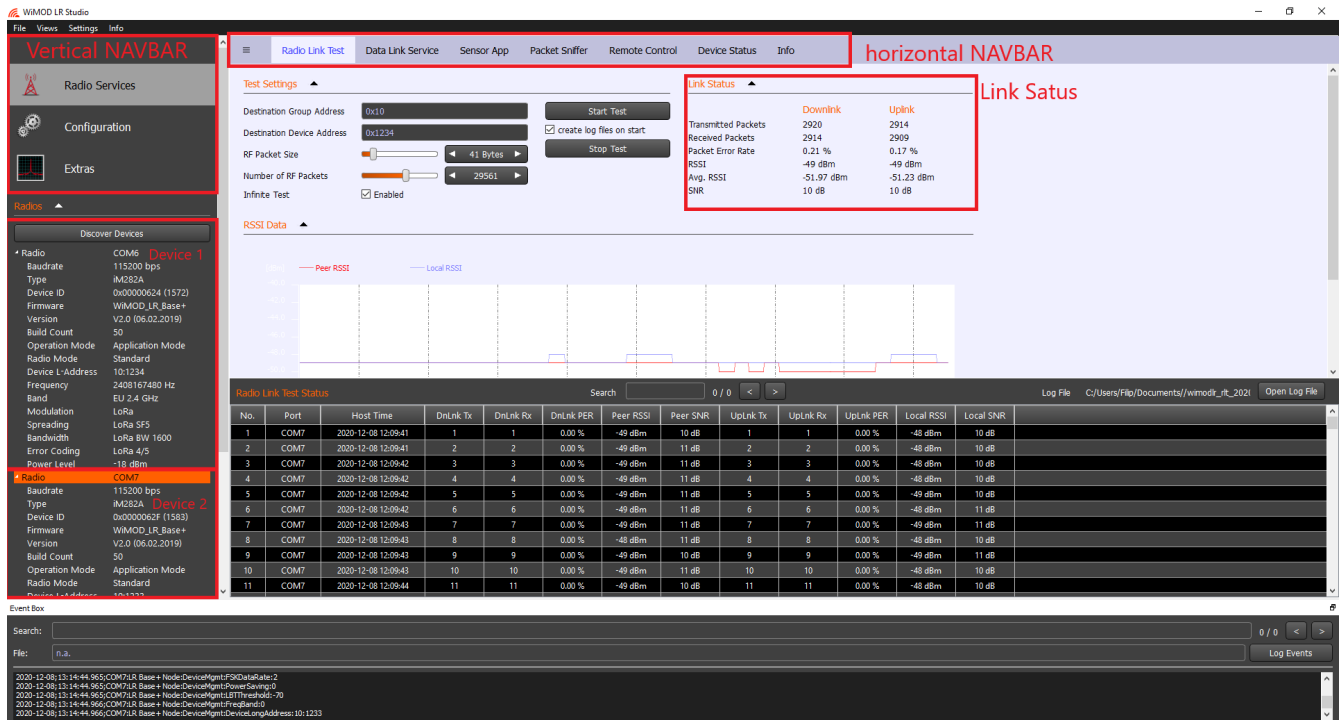

Obrázek 8: WiMoD LR studio: Radio Services

Nastavení Parametrů pro Tx a Rx modul ve WiMOD LR studiu:

- Destination Group Address: Destination Group Address RX modulu
- Destination Device Address: Destination Device Address RX modulu
- RF Packet size: 15 Bytes
- Number of RF Packets: PER se ve WiMOD LR studiu počítá průběžně ze všech přijatých packetů a měření se resetuje po přijetí počtu packetů nastavené v tomto poli Pro časovou náročnost měření zvolte nejnižší hodnotu (100)
- Infinite Test: Enabled
- Create log files on start: nechte nezaškrtnuté
- Test probíhá po stisknutí tlačítka "Start Test" z zařízení, které je zvoleno v levém vertikálním navbaru do zařízení, které je zadáno v poli Destination Device Address, proto je nutné před zahájením testu zvolit v levém navbaru TX modul
- Zahajte test stisknutím tlačítka "Start Test"**

4. Nastavení spektrálního analyzátoru a výstupního výkonu *C* LoRa modulu. Na spektrálním analyzátoru budou měřeny spektrální výkony obou systémů (LoRa i Bluetooth). Pro každý SF LoRa systému stačí však výstupní výkon LoRa modulu *C* změřit pouze jednou, protože v průběhu měření bude konstantní. Pro měření LoRa signálu je nutné odpojit RX modul z důvodu, že komunikace mezi LoRa moduly probíhá obousměrně.

Nastavení Parametrů pro spektrální analyzátor:

- Center Frequency: stejná jako Center Frequency LoRa modulů
- Nastavení šířky pásma: BW → **RES BW MANUAL 300 kHz**, BW → **VIDEO BW MANUAL 3MHz**
- SPAN: **SPAN 5 MHz**
- Měření výkonu: MEAS → CHAN PWR ACP → CP/ACP: ON → CP/ACP CONFIG → **CHANNEL BANDWIDTH: 4 MHz**. Ujistěte zda se měření spektrum nachází je uvnitř červených čar (viz Obr. 9) Pokud tomu tak není zopakujte nastavení CHANNEL BANDWIDTH
- SWT: Vzhledem k tomu, že má LoRa nízkou přenosovou rychlost a modul otevírá po vysílání zprávy Rx okna, je nutné nastavit vyšší Sweep Time pro správné zobrazení a měření přenášeného výkonu. Nastavte SWT (SWEEP → **SWT MANUAL**) **na 12 s** (případně i vyšší)
- Pomocí attenuátoru nastavte výstupní výkon LoRa modulu, tak aby byl výstupní výkon na spektrálním analyzátoru **-65 dBm**. Při tomto kroku se ujistěte, že máte odpojený RX modul (odšroubovaný SMA konektor viz Obr. 10) a vypnutý výstup generátoru. Změřený výkon (okolo -65 dBm) bude představovat výkon rušeného LoRa zařízení *C*
- Opět připojte Rx modul a zkontrolujte, zda probíhá test ve WiMoD LR studiu

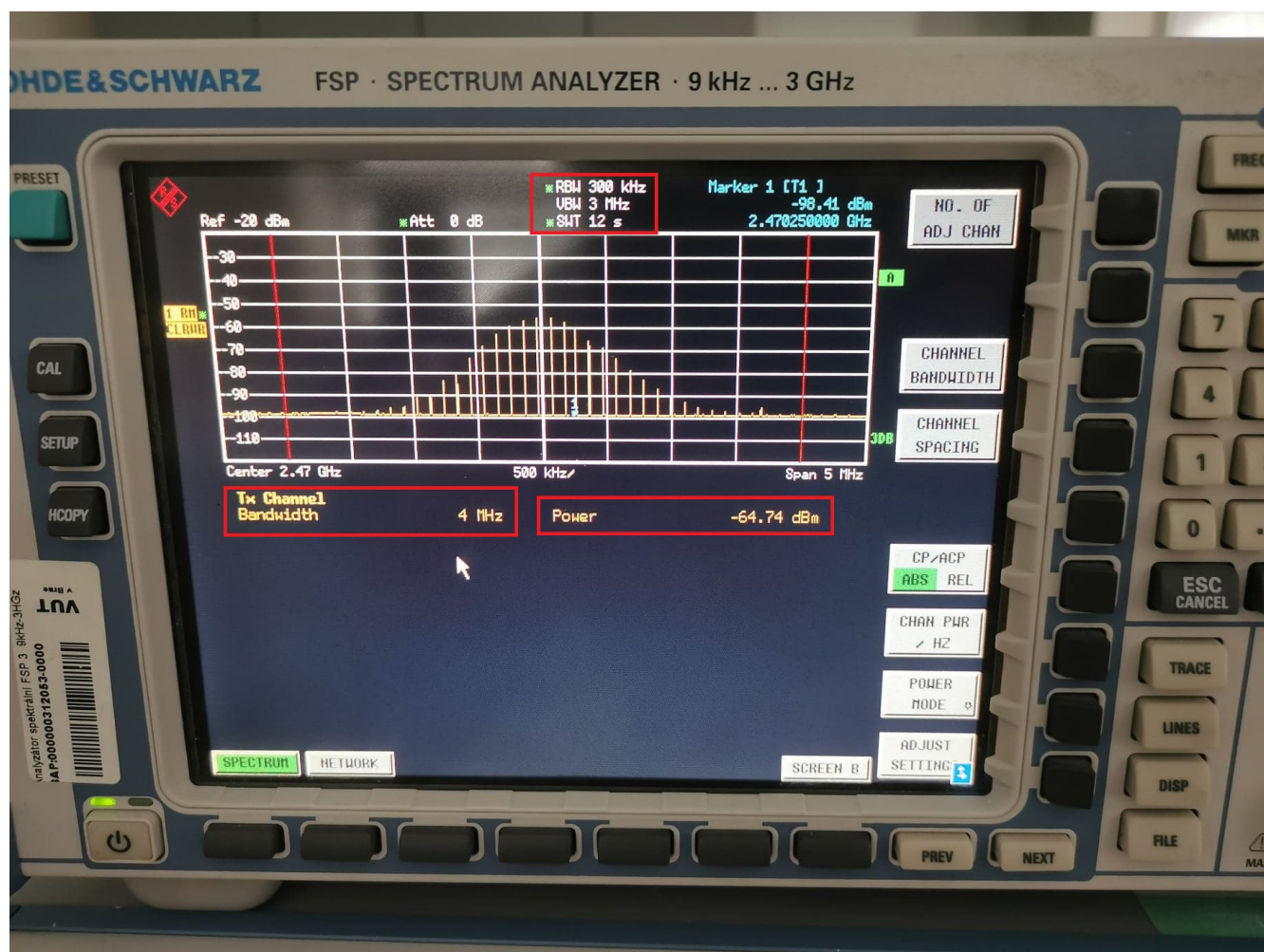

Obrázek 9: Spektrální analyzátor: měření výkonu

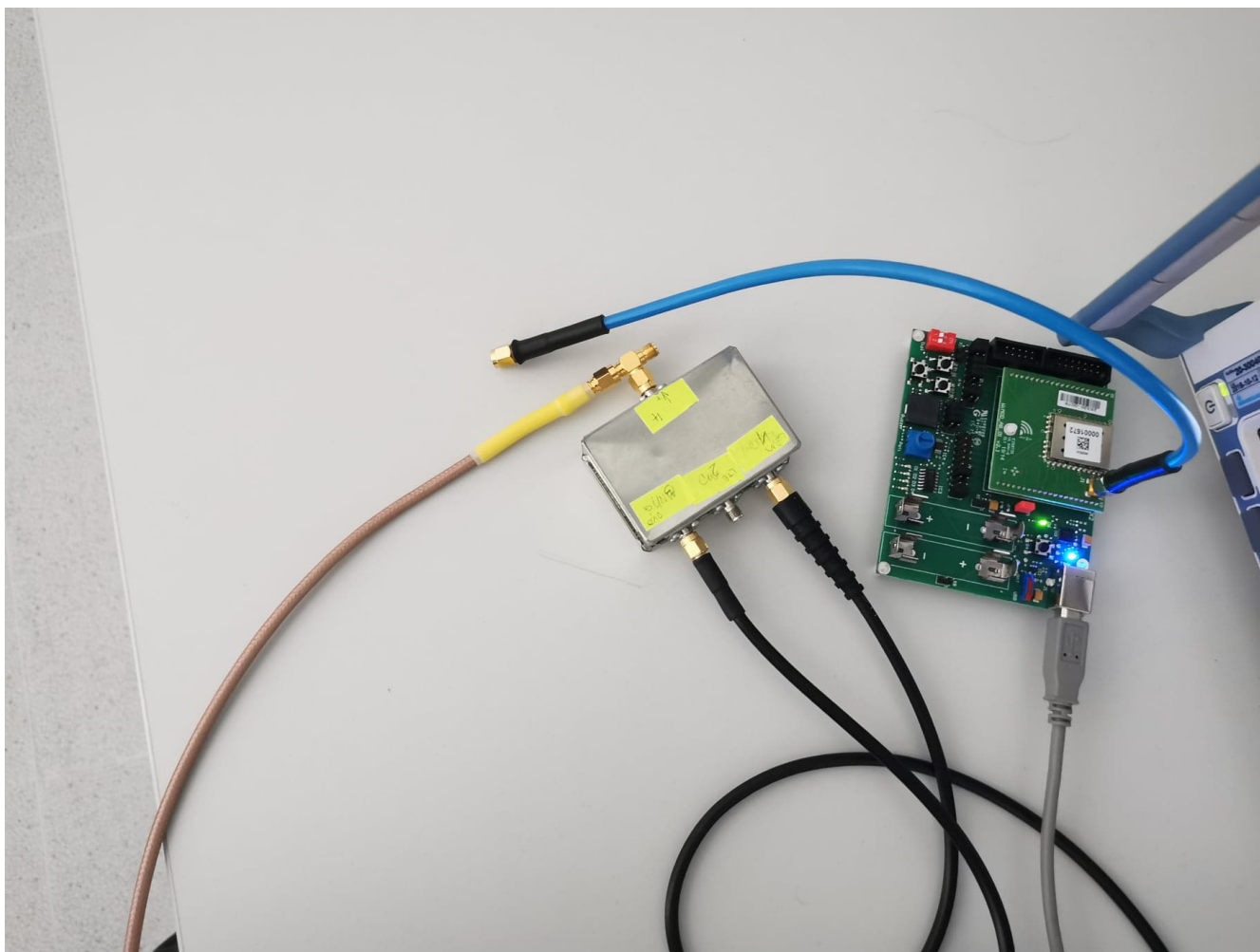

Obrázek 10: Odpojení Rx modulu

5. Nastavení Generátoru a měření spektrálního výkonu Bluetooth I. Generátor R&S SMU 200A umožňuje generovat Bluetooth signál s možností nastavení výstupního výkonu a volby center frequency f_c . Generátor je možné ovládat ručně nebo pomocí počítačové myši připojené přes USB.

Nastavení Parametrů pro Generátor:

- Ověřte do kterého kanálu je připojen propojovací koaxiální kabel a pro tento kanál proveďte následující nastavení.
- Zvolte typ modulace (viz. Obr. 11): Config → Custom digital modulation → Set acc to standart: Bluetooth → Symbol Rate 1Msym/s → Coding off → Modulation type: 2FSK → FSK deviation: 160kHz, Filter: GAUS(FSK), BT: 0.5
- Center frequency:** podle offsetu (viz tabulka 1), pro první měření stejná jako u LoRa modulu (2,47 GHz). Při změně offsetu, tudíž i center frequency je nutné pro správné měření změnit i center frequency na spektrálním analyzátoru
- Výstupní výkon: v pravém horním rohu je možné nastavit výstupní výkon generátoru. Kolečkem myši nastavte výkon na úroveň nižší než **-70 dBm** a aktivujte výstup generátoru zatržením posledního bloku v diagramu (RF/A Mod on)
- Postupně zvyšujte výstupní výkon do doby, než se hodnota PER (měřeno ve WiMOD LR studiu) bude blížit 10%. Vzhledem k malému počtu přenesených packetů se Vám pravděpodobně nepodaří nastavit přesných 10% (hodnoty $\pm 5\%$ jsou v pořádku) Všimněte si také, že při zvyšování výkonu rušivého Bluetooth signálu klesá SNR. Pro urychlení měření lze využít právě hodnot SNR, kde **PER = 10%** přibližně odpovídá určité hodnotě SNR. Pro měřené SF jsou odpovídající hodnoty SNR umístěny v tabulce (tab. 1)

f) Po dosažení **PER = 10%** vypněte test (tlačítkem stop test ve WiMoD Studiu). Změřte výkon Bluetooth signálu na spektrálním analyzátoru (nyní měříte pouze výkon Bluetooth signálu, který má přenosovou rychlost 1 Mbit/s můžete tak nastavit na spektrálním analyzátoru nižší **SWT (200ms)** pro rychlejší měření). Hodnotu výkonu I zaznamenejte do tabulky

g) Opakujte měření podle bodu 5.) pro frekvenční offsety (viz tabulka) do doby, než by pro rušení byl potřebný výkon generátoru vyšší než **-5 dBm**

Měření opakujte pro **SF 5, 8 a 12**, které nastavíte podle bodu 2. j). Pro každý SF je nutné znova nastavit výstupní výkon LoRa modulu pomocí atenuátoru na **-65 dBm**. **Vyneste závislosti C/I na Δ_f pro jednotlivé SF do jednoho grafu a zpracujte přehlednou zprávu z měření.**

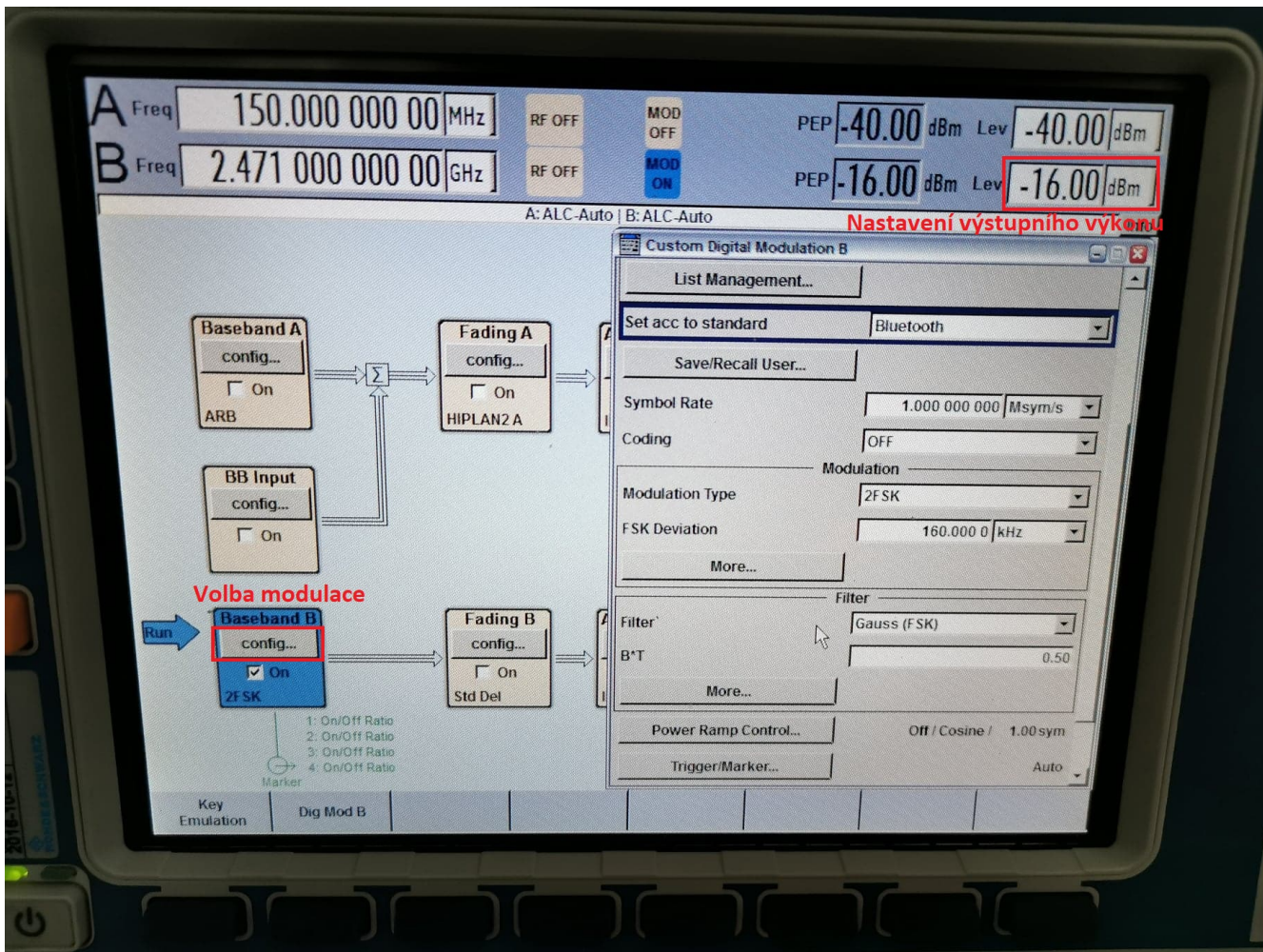

Obrázek 11: Generátor: screen obrazovky

Table 1: Tabulka naměřených hodnot

BW = 400[kHz]		SF5, SNR at PER 10% = cca -1.5 dB			SF8, SNR at PER 10% = cca -10 dB			SF12, SNR at PER 10% = cca 20 dB		
Δ_f [kHz]	f_c BL [MHz]	C_{LoRa} [dBm]	I_{BL} [dBm]	C/I [dB]	C_{LoRa} [dBm]	I_{BL} [dBm]	C/I [dB]	C_{LoRa} [dBm]	I_{BL} [dBm]	C/I [dB]
0		-65			-65			-65		
150		-65			-65			-65		
300		-65			-65			-65		
450		-65			-65			-65		
600		-65			-65			-65		
750		-65			-65			-65		

Reference, doporučená literatura

- [1] Semtech, Bluetooth Immunity of LoRa at 2.4 GHz [online]. April 2018 [cit. 28.10.2020]. Dostupné z: <<https://semtech.my.salesforce.com/sfc/p/#E0000000Je1G/a/2R000000HSNz/HeroVQVf0kV2KaLGS7BiPaFWWoCXVsrP3rFKf9hs6JQ>>.
- [2] Polák Ladislav, Miloš Jiří, Performance analysis of LoRa in the 2.4 GHz ISM band: coexistence issues with Wi-Fi [online]. July 2020 [cit. 20.02.2021]. Dostupné z: <https://www.researchgate.net/publication/339714225_Performance_analysis_of_LoRa_in_the_24_GHz_ISM_band_coexistence_issues_with_Wi-Fi>.
- [3] Kauciarik Filip, Koexistence systémů LoRa a Wi-Fi v RF pásmu 2.4 GHz. [online]. 16.6.2020 [cit. 17.10.2020]. Dostupné z: <<https://www.vutbr.cz/studenti/zav-prace/detail/126128>>.
- [4] Semtech, What are LoRa® and LoRaWAN® ? [online]. 11.2.2020 [cit. 17.10.2020]. Dostupné z: <<https://loro-developers.semtech.com/library/tech-papers-and-guides/loro-and-lorawan/>>.

Naměřené hodnoty a příklady výpočtů

BW = 400[kHz]		SF5, SNR at PER 10% = cca -1.5 dB			SF8, SNR at PER 10% = cca -10 dB			SF12, SNR at PER 10% = cca 20 dB		
Δf [kHz]	f_c BL [MHz]	C_{LoRa} [dBm]	I_{BL} [dBm]	C/I [dB]	C_{LoRa} [dBm]	I_{BL} [dBm]	C/I [dB]	C_{LoRa} [dBm]	I_{BL} [dBm]	C/I [dB]
0	2470	-65	-45,91	-18,79	-65	-44,9	-20,58	-65	-37,7	-26,9
150	2470,15	-65	-44,42	-20,28	-65	-43,62	-21,86	-65	-36,82	-27,78
300	2470,3	-65	-39,6	-25,1	-65	-38,5	-26,98	-65	-31,64	-32,96
450	2470,45	-65	-32,85	-31,85	-65	-32,02	-33,46	-65	-25	-39,6
600	2470,6	-65	-25,64	-39,06	-65	-24,03	-41,45	-65	-18,58	-46,02
750	2470,75	-65	-18,5	-46,2	-65	-	-	-65	-	-

$$C/I[\text{dB}] = C - I = -65 \text{ dBm} - (-45.91 \text{ dBm}) = -18.79 \text{ dB}$$

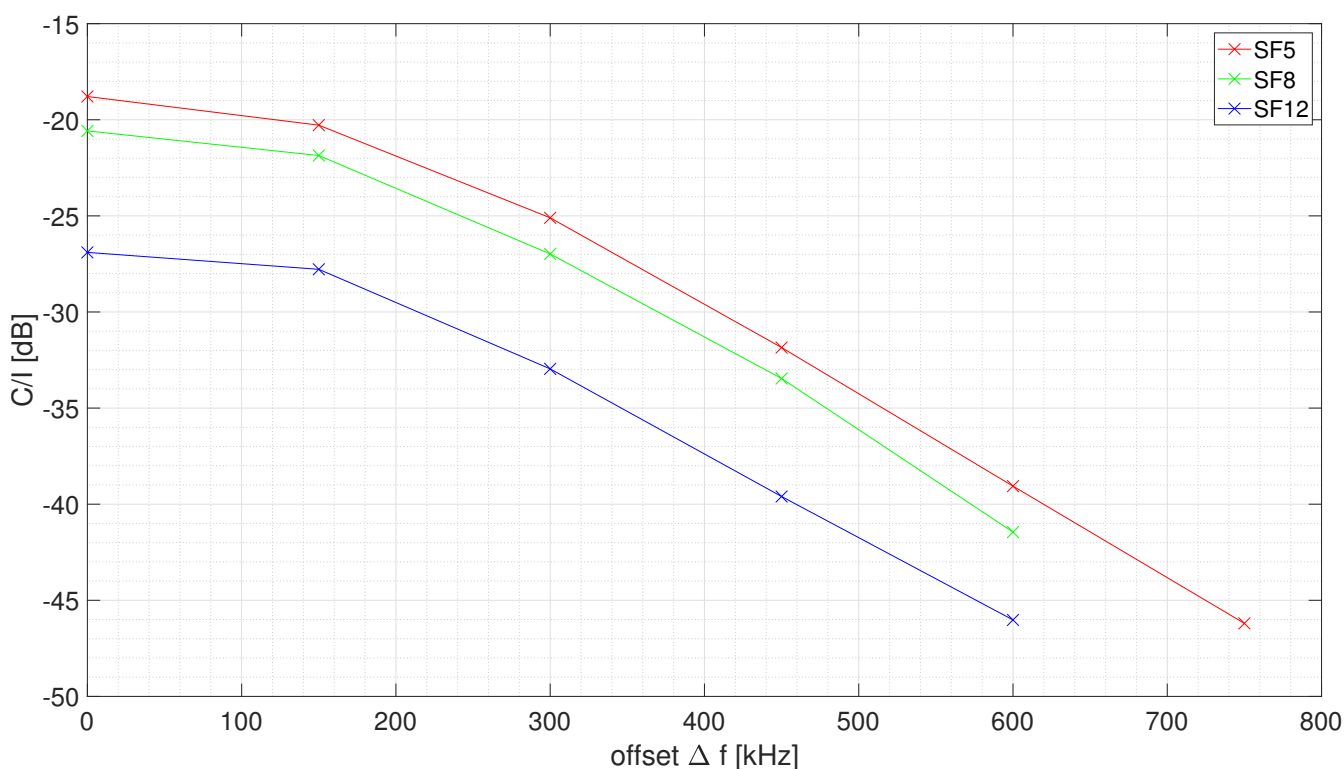

Obrázek 1: Změřené závislosti C/I na Δf pro SF 5, 8 a 12 při LoRa BW 400 kHz

Závěr

Maximální Δf_{max} , kterého se při měření podařilo dosáhnout byl 750 kHz. Z toho vyplývá, že měření zahrnuje Co-channel a In-Band koexistenční scénáře. Na obrázku výše můžeme vidět jednotlivé závislosti PR (C/I) na Δf pro různé SF. Obecně platí, že čím nižší je hodnota PR tím odolnější systém je. Proto lze usoudit, že je LoRa nejodolnější vůči rušení při SF 12 a naopak nejméně odolná při SF 5. Pokud vyčíslíme PR v $\Delta f = 0$ získáme tak informaci o odolnosti LoRa systému v Co-Channel scénáři. Jako příklad uvažujme SF 12, který má při $\Delta f = 0$ PR = -26.9 dB. Pokud přejdeme do Inband koexistenčního scénáře ($\Delta f > 0$). Vidíme, že s rostoucím Δf klesá PR, což označuje rostoucí odolnost LoRa systému. To je způsobeno, tím, že s rostoucím Δf dochází k zmenšení překryvu spekter. Vzhledem k šířce pásma LoRa (BW = 400 kHz) a Bluetooth (BW = 1 MHz) lze uvažovat, že rušení má širokopásmový charakter.

Seznam použitých přístrojů

1. LoRa modules SK-iM282-A
2. Signal Analyzer R&S FSQ
3. Signal Generator R&S SMU200A
4. PC with WiMoD LR studio software
5. Wilkinson power splitter/combiner
6. Attenuator vhodný s pracovní frekvencí 2,4 GHz