

**Czech University of Life Sciences in Prague**  
**Faculty of Economics and Management**  
Department of Information Engineering



Diploma Thesis

Development and Implementation of CRM System to Small IT Service  
Companies using .NET technology

Author: Azizbek Murhonov

Supervisor: Doc.Ing. Vojtěch Merunka, Ph.D.

© Prague, 2011

## **Declaration**

I declare that I have worked on my thesis titled “Development and Implementation of CRM System to Small IT Service Companies using .NET technology” by myself and I have used only the sources mentioned at the end of the thesis.

In Prague on

.....

Signature

## **Acknowledgement**

I would like to thank to Doc.Ing. Vojtěch Merunka, Ph.D. for his useful advice and support during my work on this Thesis.

I would like to sincere gratitude to my wife, family and friends for all the support.



Development and Implementation of CRM  
System to Small IT Service Companies  
using .NET technology

## **Abstract**

Good customer relationships are the heart of organizational success. The world today has come to recognize that positive relationships with customers are crucial to an organization's long-term success. IT service organizations are no exception. These organizations face greater challenge as they must sustain good relationship with customers and ensure quality services are provided. This thesis discusses development and implementation of CRM system to IT-based Company in order to achieve strong customer relationship. The project goes through 5 major phases which includes Strategy, Requirements, Design, Development and Implementation. Contents structure, a use case diagram, sequence diagrams and relational database diagrams were designed as a preliminary approach to developing CRM. In final step described how the end products of this projects as developed by the researcher will be implemented.

**Keywords:** CRM, IT Services, .NET, ADO.NET, C#, MSSQL, OOP, UML

## **Abstrakt**

Dobré vztahy se zákazníky jsou srdcem organizačního úspěchu. Dnešní svět přišel uznal, že pozitivní vztahy se zákazníky jsou rozhodující pro organizaci dlouhodobý úspěch. IT servisní organizace nejsou výjimkou. Tyto organizace čelí větším problémem, že musí udržovat dobré vztahy se zákazníky a zajištění kvality služeb jsou poskytovány. Tato práce se zabývá vývojem a implementace CRM systému IT-společnosti založené za účelem dosažení silných vztahů se zákazníky. Projekt prochází 5 hlavních fází, která zahrnuje strategii, požadavky, design, vývoj a implementace. Obsah struktura, use case diagram, sekvenční diagramy a relační databáze diagramy byly navrženy jako předběžný přístup k rozvoji CRM. V posledním kroku je popsáno, jak bude konečné produkty této projektů, vyvinuté výzkumným pracovníkem být prováděna.

**Klíčová slova:** CRM, IT Services, .NET, ADO.NET, C#, MSSQL, OOP, UML

## List of figures

Figure 2-1 The CRM Hierarchy (Maslow revisited, adapted from Kincaid, 2003).....	5
Figure 2-2 CRM Program Lifecycle (Adapted from Kincaid, 2003).....	10
Figure 2-3 Strategic planning process and tools .....	12
Figure 2-4 CRM Solution Map (Adapted from Greenberg, 2001) .....	16
Figure 2-5 Elements of CRM (Adapted from Tourniaire, 2003).....	16
Figure 2-6 How CRM Works (Adapted from Timm and Jones, 2004) .....	19
Figure 2-7 IT Delivery Process (Adapted from Bruton, 2004).....	21
Figure 3-1 Project Solution Roadmap .....	25
Figure 3-2 ITManagerCRM Lifecycle (Adapted from Kincaid, 2003).....	28
Figure 3-3 CRM Elements.....	28
Figure 4-1 Use-case diagram for ITManagerCRM.....	32
Figure 4-2 Login Sequence Diagram .....	35
Figure 4-3 ViewServiceCatalog Sequence Diagram.....	36
Figure 4-4 UseServices Sequence Diagram .....	36
Figure 4-5 ManageProfile Sequence Diagram.....	37
Figure 4-6 Logout Sequence Diagram .....	37
Figure 4-7 ManageApplication Sequence Diagram.....	38
Figure 4-8 ViewProjects Sequence Diagram.....	38
Figure 4-9 ADO.NET Entity Framework diagram for ITManagerCRM .....	39



## **List of tables**

Table 3-1 Strategic Planning Process (Adapted from Kincaid, 2003) .....	11
Table 3-2 Building Infrastructure Steps (Adapted from Kincaid, 2003).....	12
Table 3-3 Assess Customer Steps (Adapted from Kincaid, 2003) .....	14
Table 3-4 Deliver Customer Offer Steps by Kincaid (2003).....	14
Table 3-5 Types of IT Services.....	22
Table 3-1 CRM Actors features .....	29
Table 4-1 Steps and purposes for strategy development .....	31

## Table of Contents

Acknowledgement.....	III
Abstract.....	VI
Abstrakt .....	VII
List of figures.....	VIII
List of tables.....	IX
1. Introduction.....	1
1.1. Study background.....	1
1.2. Study area .....	2
1.3. Goal and Methodology.....	2
2. Literature Review.....	3
2.1. Customer Relationship Management .....	3
2.1.1 Definition of CRM.....	3
2.1.2 Goal and Benefits of CRM .....	4
2.1.3 CRM Strategies.....	7
2.1.4 CRM Methodology .....	9
2.1.5 CRM Technology.....	15
2.2. IT Services .....	19
2.2.1 IT Services Culture .....	19
2.2.2 IT Delivery Process.....	20
2.2.3 Types of IT Services .....	22
3. Functional Requirements and Methodology.....	25
3.1. Project Methodology.....	25
3.1.1 Project Strategy.....	26

3.1.2	Project Requirements .....	26
3.1.3	Project Design.....	27
3.1.4	Project Development.....	29
4.	Software Development and Implementation .....	31
4.1.	CRM Design and Development .....	31
4.1.1	Develop a Strategy .....	31
4.1.2	Use-Case Model.....	32
4.1.3	Use-case Scenarios.....	32
4.1.4	Sequence Diagrams.....	35
4.1.5	ADO.NET Entity Framework diagram .....	39
4.2.	CRM Implementation.....	40
5.	Conclusion .....	41
6.	References.....	42

## **1. Introduction**

Customer Relationship Management is a way of doing business that touches all areas and it is enabled by information technology. To make strong relationship with customers is the success of any organization. The world today has come to recognized that positive relationships with customers are crucial to an organization's long-term success. Indeed, no business or organization can succeed without creating a base of loyal customers. Customer relationships are also believed to be the basis for achieving increased efficiency and leveraging a competitive advantage for organizations.

Today, CRM is becoming increasingly important as a strategy to learn more about customer's needs and behaviors. In other words, CRM is a strategy that starts, maintains and optimizes relationships to make customers loyal. CRM also helps organizations use technology and human resources to gain insight into the behavior of customers and the value of the customers.

Many IT Service Companies provide CRM system but it is expensive to implement to all levels of business. That is the reason we need to develop CRM for our business especially for small ones.

### **1.1. Study background**

As CRM encompasses wide aspects which include people, culture, technology, process and leadership, its implementation within an ICT service organization will give major contribution and guidance towards the organization's success.

ICT market growing too fast and IT Service Companies faces problems in creating, improving and maintaining good relationships with its customers and manage customer needs and expectations.

Realizing these problems, the researcher sees the needs to study and analyze the concepts of CRM. Integrating these concepts together shall produce a useful CRM application for small IT Service Companies.

## **1.2. Study area**

In this thesis CRM application has been developed using .NET environment. The Researcher is implementing CRM solution for the IT Service Companies to make their business activities more efficiency and maintaining good relationships with their customers.

## **1.3. Goal and Methodology**

The goal of this thesis is to discuss how CRM can be success of any organization such as IT Service Companies in order to make stronger and more profitable relationship with customers. ITManagerCRM application developed by researcher has been taken into consideration for its pros and cons.

For the methodology there are 5 major phases such as Strategy, Requirements, Design, Development and Implementation.

## **2. Literature Review**

The role of literature review is to probe into the areas that are of interest to the research study. Literature review will aid the author in having deeper understanding on the research areas. With the knowledge and understanding obtained, the author will be able to conduct and present the research study. For readers, the literature review provides a comprehensive insight of the subject background and a better review of the research study flow.

The areas under study that shall be discussed are organized around four main themes that are Customer Relationship Management (CRM) and IT Services.

### **2.1. Customer Relationship Management**

#### **2.1.1 Definition of CRM**

The definition of CRM has not been standardized, different people define the concept with different perspective and generally it can be described as a set of business applications that are responsible for management of every business processes.

CRM has been defined as “the core business strategy that integrates internal processes and functions, and external networks, to create and deliver value to targeted customers at a profit. It is grounded on high quality customer-related data and enabled by information technology” (Buttle, 2004).

According to Gartner, Inc. (2009) “Customer relationship management (CRM) is a widely-implemented strategy for managing a company’s interactions with customers, clients and sales prospects. It involves using technology to organize, automate, and synchronize business processes-principally sales activities, but also those for marketing, customer service, and technical support. The overall goals are to find, attract, and win new clients, nurture and retain those the company already has, entice former clients back into the fold, and reduce the costs of marketing and client service.”

DestinationCRM says that “If customer relationships are the heart of business success, then CRM is the valve the pumps a company's life blood. As such, CRM is best suited to help businesses use people, processes, and technology to gain insight into the behavior and value of customers. This insight allows for improved customer service, increased call center efficiency,

added cross-sell and up sell opportunities, improved close rates, streamlined sales and marketing processes, improved customer profiling and targeting, reduced costs, and increased share of customer and overall profitability.”

According to Buttle (2004) CRM can be described at three levels:

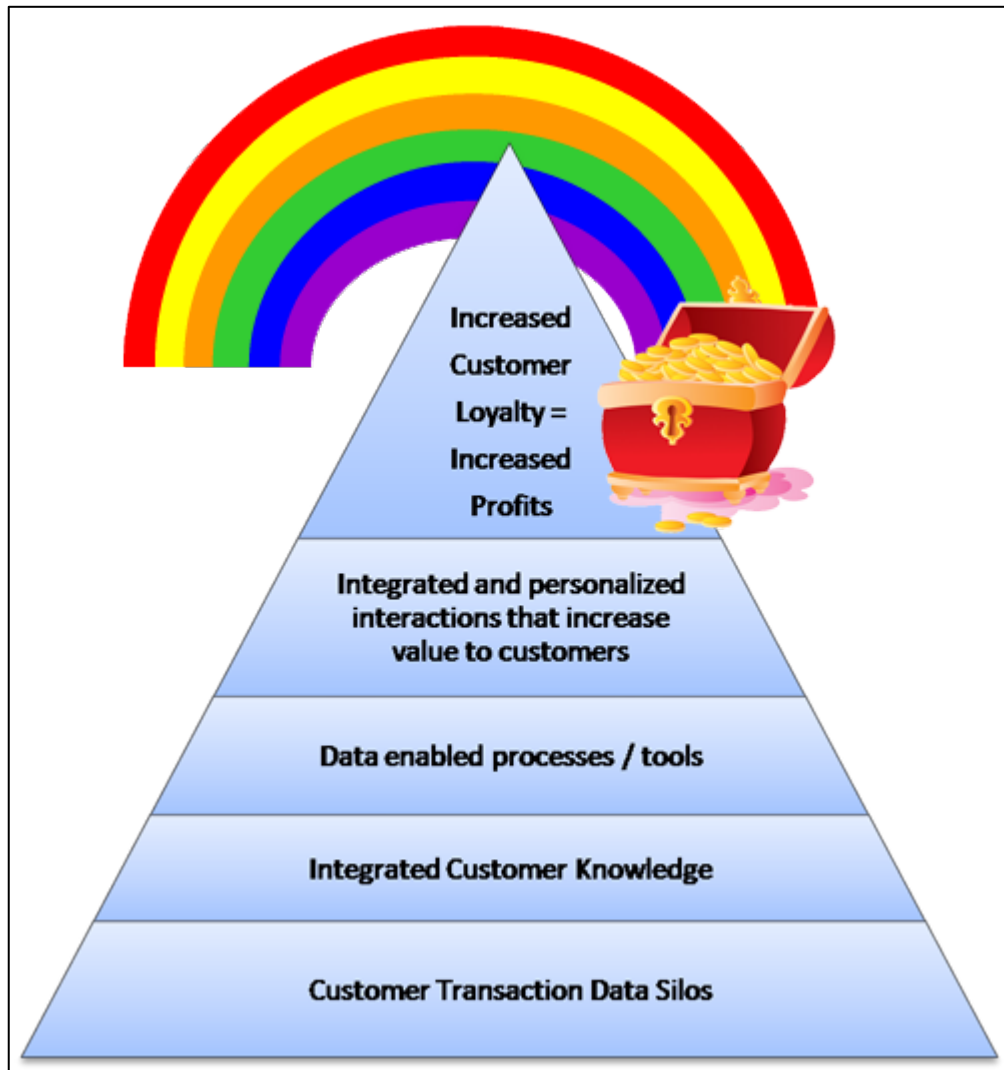
- **Strategic.** A top-down perspective on CRM which views CRM as a core customer-centric business strategy that aims at winning and keeping profitable customers
- **Operational.** A perspective on CRM which focuses on major automation projects such as service automation, sales force automation or marketing automation
- **Analytical.** A bottom-up perspective on CRM which focuses on the intelligent mining of customer data for strategic or tactical purposes

### **2.1.2 Goal and Benefits of CRM**

Main goal of any CRM system is to make stronger and more profitable relationship with customers. Some companies do this by taking cost out of the relationship; for example, by shifting customers to web-based self-service. Others do this by increasing the revenue earned from a customer relationship; for example, by selling customers additional products and services. Most companies use both of these approaches. (Buttle, 2004)

Maximum customer loyalty is the goal of CRM and it cannot be achieved overnight. This is reflected in the CRM Hierarchy with Maslow’s self-actualization pyramid adapted from Kincaid (2003) as shown in Figure 2-1 below. Kincaid mentions that you cannot jump right in at the top designing loyalty programs unless you have already addressed all the lower levels of the pyramid.

For CRM to work, it usually requires significant changes in the organization’s systems, information management practices, business processes and also organizational and employee behavior. Achieving the goal of loyal customers and increased profit takes time. Organizations must move through the levels of the CRM hierarchy one at a time. They must first satisfy basic needs such as integrating their customer information and application silos, redesigning processes and educating their employees.



**Figure 2-1 The CRM Hierarchy (Maslow revisited, adapted from Kincaid, 2003)**

When company implements properly CRM then it can bring a lot of tangible benefits.

According to CustomerServicePoint CRM system can bring:

- **Shared or distributed data**

As companies realize that customer relationships are happening on many levels (not just through customer service or a web presence), they start to understand the need for sharing all available data throughout the organization. A CRM system is an enabler for making informed decisions and follow-up, on all the different levels.



- **Cost reduction**

A strong point in Customer Relationship Management is that it is making the customer a partner in your business, not just a subject. As customers are doing their own order entry, and are empowered to find the info they need to come to a buy decision, less order entry and customer support staff is needed.

- **Better Customer Service**

All data concerning interactions with customers is centralized. The customer service department can greatly benefit from this, because they have all the information they need at their fingertips. No need to guess, no need to ask the customer for the n-th time. And through the use of push-technology, customer service reps can lead the customer towards the information they need. And, most of the time, the customer can do this on their own, as the CRM system (remember, the 3 P's) is more and more able to anticipate the need of the customer. The customer experience is greatly enhanced.

- **Increased Customer Satisfaction**

The customer feels that he is more "part of the team" instead of just a subject for sales and marketing (the proverbial number), customer service is better, his needs are anticipated. There is no doubt that customer satisfaction will go up. If the products sold exceed the customer's expectation, of course, no CRM system can help you with shoddy products. In my opinion, the term satisfaction is a contaminated. Many companies think that if customers are satisfied that this is a good predictor for repeat business. However, this is not the case. Only delighted customers have a great level of loyalty.

- **Better Customer Retention**

If a CRM system can help to enchant customers, this will increase customer loyalty, and they will keep coming back to buy again and again, hence customer retention.

- **Customer loyalty**

All business needs to build customer loyalty, but small organizations- and especially those looking to establish themselves – need to pay particularly close attention to providing excellent customer service.

- **More repeat business**

The repeat business is coming from the delighted customers, who are turned from doubting clients into loyal advocates.

- **More new business**

If you are delivering the ultimate customer experience, this will seed the word-of-mouth buzz, which will spawn more new business.

- **More profit**

More business at lower cost equals more profit.

### 2.1.3 CRM Strategies

For larger-scale enterprises, a complete and detailed plan is required to obtain the funding, resources, and company-wide support that can make the initiative of choosing and implementing a system successfully. Benefits must be defined, risks assessed, and cost quantified in three general areas:

- **Processes:** Though these systems have many technological components, business processes lie at its core. It can be seen as a more client-centric way of doing business, enabled by technology that consolidates and intelligently distributes pertinent information about clients, sales, marketing effectiveness, responsiveness, and market trends. Therefore, a company must analyze its business workflows and processes before choosing a technology platform; some will likely need re-engineering to better serve the overall goal of winning and satisfying clients. Moreover, planners need to determine the types of client information that are most relevant, and how best to employ them. (DestinationCRM, 2002)
- **People:** For an initiative to be effective, an organization must convince its staff that the new technology and workflows will benefit employees as well as clients. Senior executives need to be strong and visible advocates who can clearly state and support the case for change. Collaboration, teamwork, and two-way communication should be encouraged across hierarchical boundaries, especially with respect to process improvement. (TechTarget, 2009)
- **Technology:** In evaluating technology, key factors include alignment with the company's business process strategy and goals, including the ability to deliver the right

data to the right employees and sufficient ease of adoption and use. Platform selection is best undertaken by a carefully chosen group of executives who understand the business processes to be automated as well as the software issues. Depending upon the size of the company and the breadth of data, choosing an application can take anywhere from a few weeks to a year or more. (DestinationCRM, 2002)

According to Buttle (2004) following five stages of the CRM value chain represents three main sequential phases of CRM strategy: analysis, resource development and implementation:

1. **Customer portfolio analysis:** this involves an analysis of the actual and potential customer base to identify which customers you want to serve in the future. Top of the list will be strategically significant customers, including those that will generate profit (value) in the future.
2. **Customer intimacy:** you will get to know the identity, profile, history, requirements, expectations and preferences of the customers that you have chosen to serve.
3. **Network development:** you will identify, brief and manage relationships with your company's network members. These are the organizations and people that contribute to the creation and delivery of the value proposition(s) for the chosen customers. The network can include external members such as suppliers, partners and owners/investors, as well as one important internal party, employees.
4. **Value proposition development:** this involves identifying sources of value for customers and creating a proposition and experience that meet their requirements, expectations and preferences.
5. **Manage the customer lifecycle:** the customer lifecycle is the customer's journey from 'suspect' towards 'advocate status'. Managing the lifecycle requires attention to both process and structure:
  - **Process:** how will the company go about the important processes of customer acquisition, customer retention and customer development, and how will it measure the performance of its CRM strategy?
  - **Structure:** how will the company organize itself to manage customer relationships?

#### **2.1.4 CRM Methodology**

Methodologies allow organizations to learn from previous experience and to get better and faster at what they do. Timm and Jones (2004) propose 5 Steps for deploying CRM. The steps are:

Step 1: Develop a Customer Strategy First

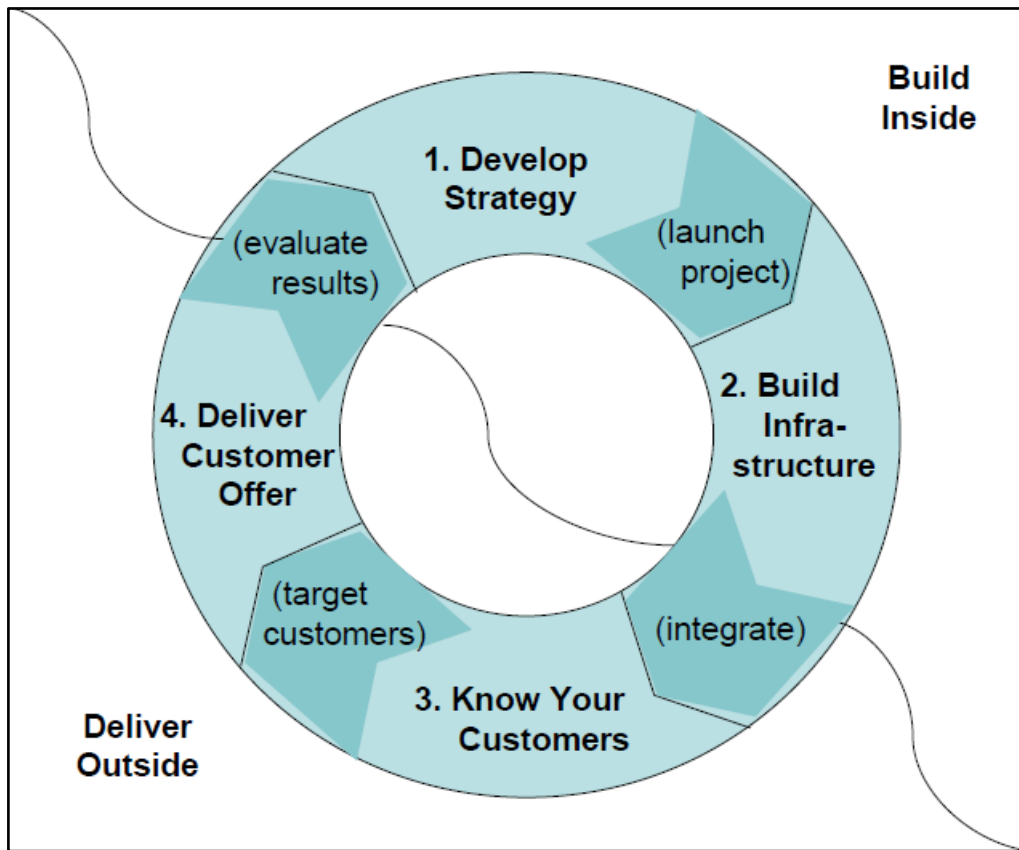
Step 2: Align the Organization and Its Processes

Step 3: Adopt Appropriate Technology

Step 4: Measure Benefits

Step 5: Build the Right Relationship the Right Way

On the other hand Kincaid (2003) argues that CRM is not a linear method. Generally, a CRM program is made up of all the individual CRM projects. To ensure successful integration of all these projects, organizations must follow a well-defined method. Figure 2-2 shows the entire methodology that is necessary to ensure delivery of a CRM program that achieves business goals.



**Figure 2-2 CRM Program Lifecycle (Adapted from Kincaid, 2003)**

Referring to Figure 2-2 above, the CRM life cycle is shown as a circle specifically because the method is not linear. The steps are repeated until appropriate level of CRM implementation to meet the organization’s needs is achieved. At the end of the first project, results are evaluated, strategies are reassessed based on those results and then the organization will begin planning for the next highest priority project. This methodology and lifecycle will be the basis of implementing ITManagerCRM as the steps are comprehensive.

There are four phases in the CRM lifecycle with four well-defined transition steps connecting them. **Phase 1** begins by creating a vision and a strategy so that the organizations know what they want to achieve. The process also helps them understand their business, priorities and competitive position so that they can pick the best place to begin. **Phase 2** involves creating the supporting infrastructure while remembering that CRM is more than just technology. After necessary work has been done internally, organizations may now take the new capability or

campaign to their customers. **Phase 3** starts by identifying specific customers to include in the new capability. The last phase which is **Phase 4** is where organizations will deliver the benefit to these targeted customers.

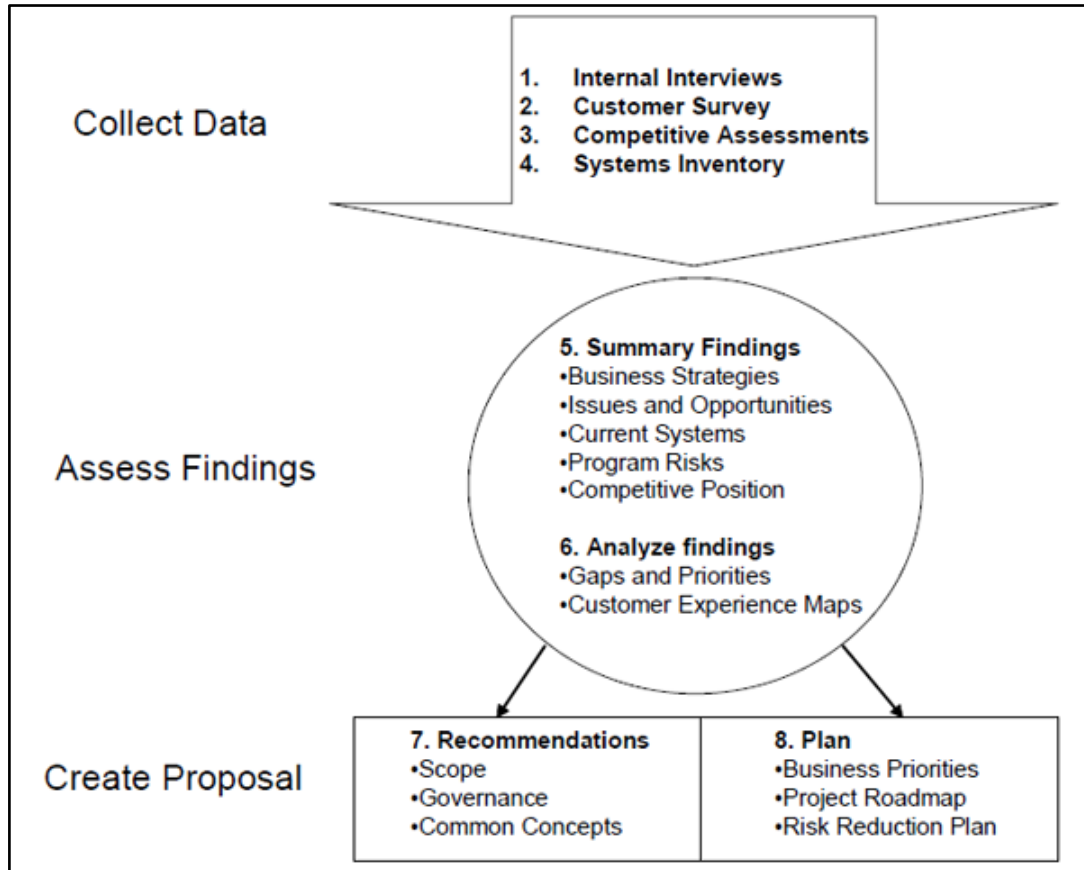
### **Phase 1 – Develop a Strategy**

The strategy and planning phase of CRM life cycle encompasses surveys of key internal and external stakeholders. It produces a set of documents or blueprints. Table 2-1 below shows the main steps involved and the purposes:

**Table 2-1 Strategic Planning Process (Adapted from Kincaid, 2003)**

<b>Step</b>	<b>Purpose</b>
Collect Data	<ul style="list-style-type: none"> <li>• Ensure that the CRM program is aligned with company strategy.</li> <li>• Discover what customers think about your current performance. What do they want more of? What makes it difficult to do business with you? How do you compare to competitors?</li> <li>• Understand all the customers’ project and functional silos that currently exist.</li> </ul>
Assess Findings	<ul style="list-style-type: none"> <li>• Identify business strategies, risks, and opportunities that will influence your CRM program.</li> <li>• Identify gaps between the goal and today’s reality</li> <li>• Define high-level customer segments.</li> </ul>
Create a Proposal	<ul style="list-style-type: none"> <li>• Define a common vision and language about what CRM is for your company.</li> <li>• Ensure that key constituents understand and support the strategy.</li> </ul>
Transition: Launch Project	<ul style="list-style-type: none"> <li>• Select the best project to tackle first (or next).</li> <li>• Determine scope, schedule, and resources.</li> </ul>

In order to carry out these four steps, Kincaid (2003) states that there are ten tools which can be utilized as shown in Figure 2-3:



**Figure 2-3 Strategic planning process and tools**

**Phase 2 – Build the Infrastructure**

The focus of Phase 2 is the analysis, design and construction of all the infrastructure elements required to meet the project objective. Integration occurs during the transition to Phase 3. Table 2-2 describes the detail steps in Phase 2.

**Table 2-2 Building Infrastructure Steps (Adapted from Kincaid, 2003)**

Step	Purpose
------	---------

Gather and analyze requirements	<ul style="list-style-type: none"> <li>• Identify business needs for information, process, technology and people</li> <li>• Analyze and compare to existing infrastructure</li> </ul>
Design component	<ul style="list-style-type: none"> <li>• Develop a detailed design</li> </ul>
Construct solution	<ul style="list-style-type: none"> <li>• Code and test information and technology solutions</li> <li>• Develop process and people change solutions</li> </ul>
Transition: Integrate Capability	<ul style="list-style-type: none"> <li>• Information Integration (consistency)</li> <li>• Process Integration (continuity)</li> <li>• Technology Integration (compatibility)</li> <li>• People Integration (congruity)</li> </ul>

### **Phase 3 – Know Your Customers**

Phase 3 is mainly about identifying the customer or group of customers for whom the result is intended. This involves creating customer segments or groups that respond in the same manner. CRM uses information to identify groups of similar customers and to support personalization. Segments are created as it is the only way to build relationship with thousands of customers. CRM introduces us to segments like one (Kincaid 2003), which means putting customers into natural groupings based on having similar characteristics so that they can meet these criterions:

- They are likely to react to an offer in about the same way
- They have the same value, so we want to treat them the same

Targeting customers is the transition step between getting to know the customers and delivering the offer. This is where organizations pick exactly the customers they plan to contact with their offer. Table 2-3 describes the detail steps in Phase 3.



**Table 2-3 Assess Customer Steps (Adapted from Kincaid, 2003)**

<b>Step</b>	<b>Purpose</b>
Getting Down and Dirty with the Data	<ul style="list-style-type: none"> <li>• Determine customer profiling and scoring model</li> <li>• Optimize profile coverage</li> </ul>
Segmenting Customers	<ul style="list-style-type: none"> <li>• Define most predictive segmentation strategy</li> <li>• Create Groups of customers “like one”</li> </ul>
Construct solution	<ul style="list-style-type: none"> <li>• Code and test information and technology solutions</li> <li>• Develop process and people change solutions</li> </ul>
Transition: Selecting Target Segments	<ul style="list-style-type: none"> <li>• Select customers profile values most likely to deliver the best response to the project offer</li> <li>• Identify specific customers who match that profile</li> </ul>

**Phase 4 – Deliver Customer Offer**

Phase 4 is the time to take the program outside and deliver it to the customers that have been targeted. For a CRM program, the customer offer is always aimed at generating responses from the targeted customers. These responses may be anything from buying a product to adopting a new service offering. Phase 4 also comprises of several steps that is detailed in the Table 2-4 below:

**Table 2-4 Deliver Customer Offer Steps by Kincaid (2003)**

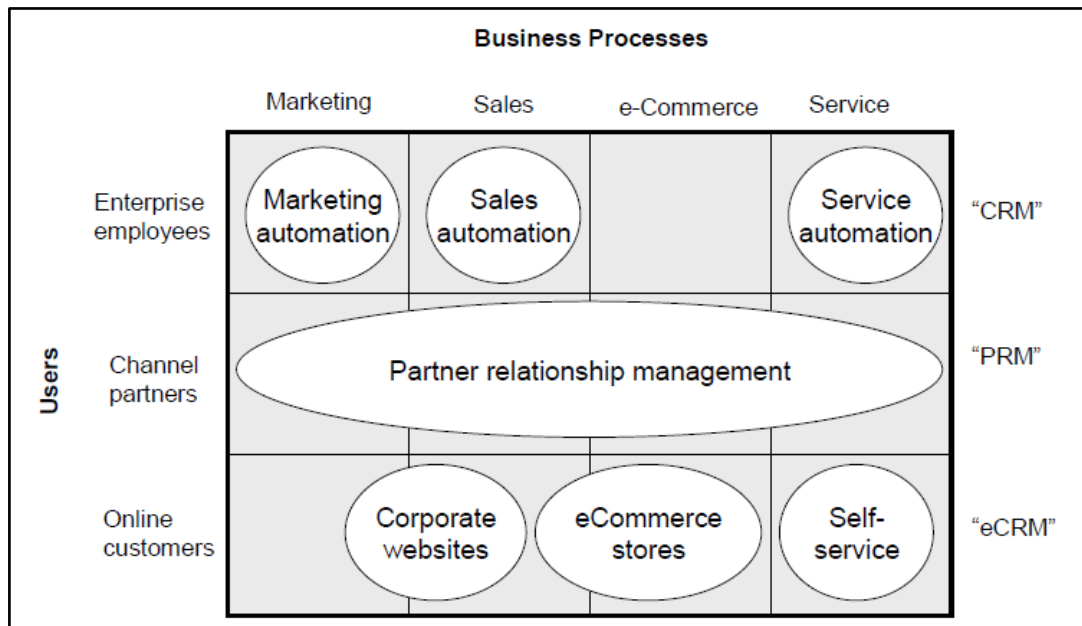
<b>Step</b>	<b>Purpose</b>
Design the offer	<ul style="list-style-type: none"> <li>• Maximize offer ROI</li> <li>• Optimize expected responses</li> </ul>
Prepare the offer message(s)	<ul style="list-style-type: none"> <li>• Develop message that matches each segment value proposition</li> <li>• Prepare to measure results</li> </ul>
Present the offer	<ul style="list-style-type: none"> <li>• Install new capability; and train customer to use it; release marketing communication</li> <li>• Minimize cost of offer delivery</li> </ul>

Transition:	<ul style="list-style-type: none"> <li>• Evaluate performance metrics</li> </ul>
Measure Results	<ul style="list-style-type: none"> <li>• Evaluate value metrics</li> </ul>

### 2.1.5 CRM Technology

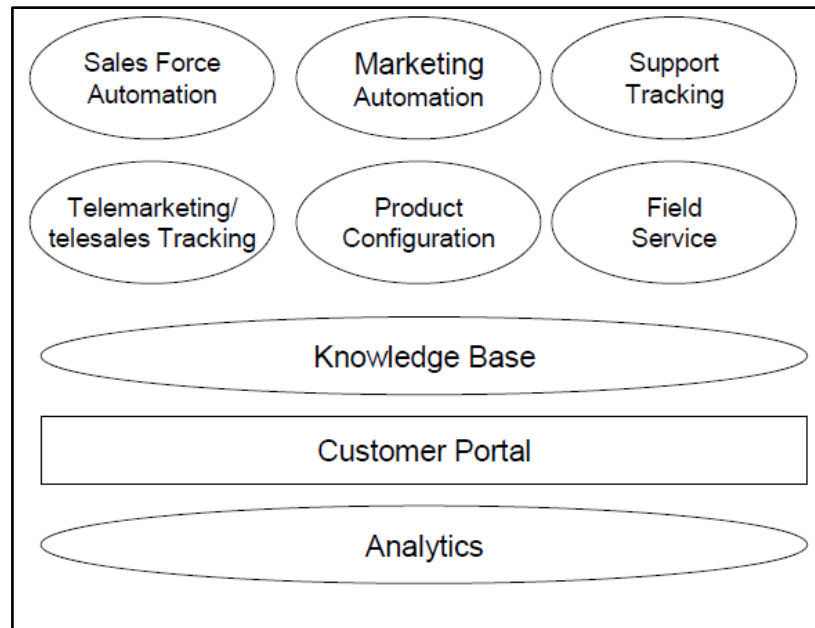
As the enabler for CRM, technology is divided into three segments which are operational, analytical and collaborative. According to Greenberg (2001), operational CRM is the customer-facing applications of CRM such as sales force automation, enterprise marketing automation and front-office suites that encompass all of this simultaneously. The analytic segment includes data marts or data warehouses for example customer repositories that are used by applications to dissect data and present it in a form that is useful to the user. The collaborative CRM which reaches across customer “touch points” includes applications for instance the partner relationship management (PRM) software. Customer touch points refer to all the different communication means that a customer might interact with such as email, phone call and fax.

CRM applications support marketing, sales, commerce and service processes as shown in the CRM Solution Map in Figure 2-4. Greenberg (2001) states that traditionally, enterprise employees have been the primary users of CRM applications. Then e-business or eCRM applications were introduced to allow enterprises to interact directly with customers via corporate websites, e-commerce storefronts and self-service applications. Finally, in 1999 PRM applications hit the market and were designed to support channel partners and other intermediaries between enterprise and its end customers.



**Figure 2-4 CRM Solution Map (Adapted from Greenberg, 2001)**

As CRM is growing into a dense and tangled field, Tourniaire (2003) presents richer functionality categories for CRM systems which consist of nine elements as shown in Figure 2-5.



**Figure 2-5 Elements of CRM (Adapted from Tourniaire, 2003)**

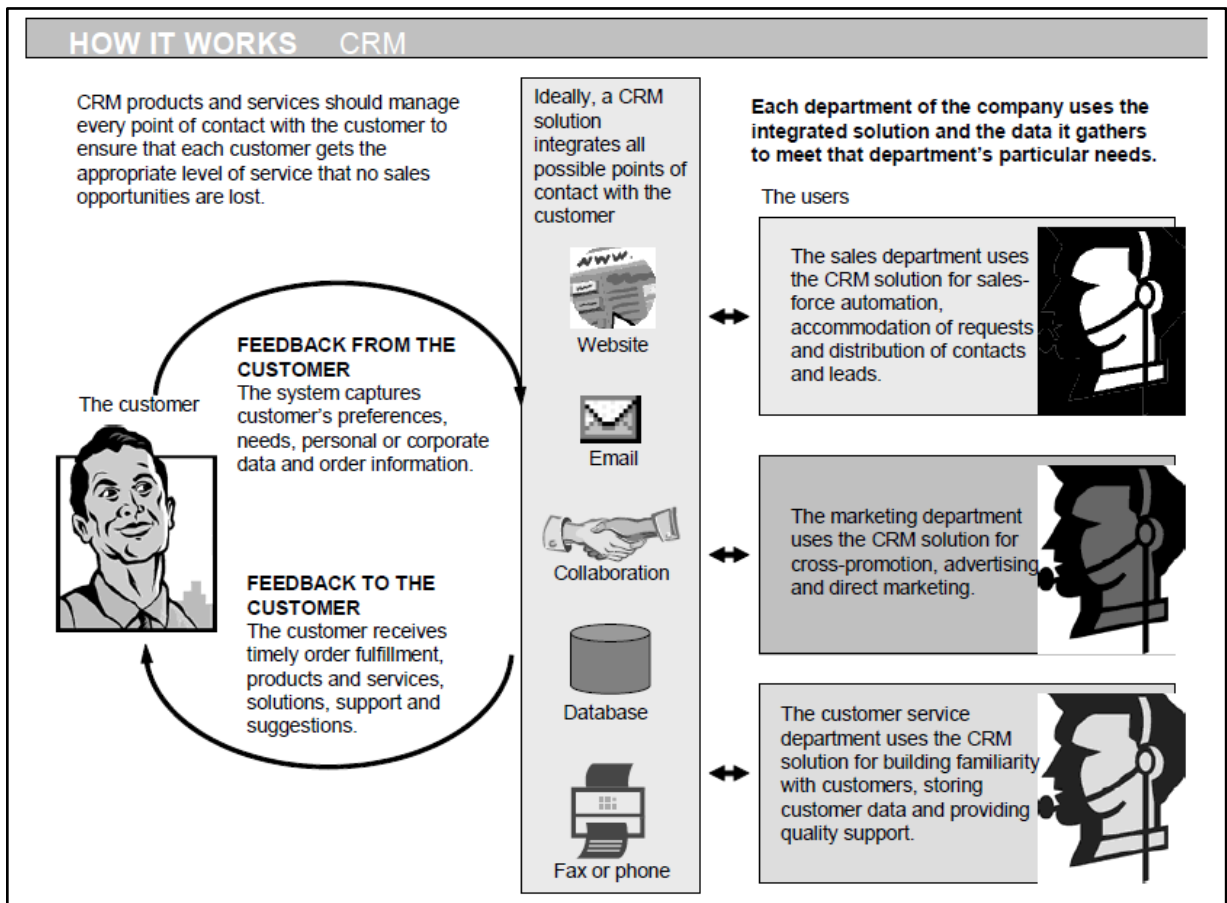
Below are the functions of each category as described by Tourniaire (2003).

- **Sales force automation (SFA).** SFA tools track prospects, contacts and activities allowing managers to follow leads through the pipeline, forecast revenue and catch bottlenecks.
- **Telemarketing and telesales tracking.** Tools for telemarketing and telesales operations are slightly different from SFA as telemarketers often work from scripts and in a structured environment. Many vendors offer contact center modules that can serve both inbound and outbound contact centers.
- **Product configuration.** Product configurators are tools that allow users to customize complex products to their exact requirements. They are now part of many CRM suites.
- **Marketing automation.** It is also called campaign management as it allows the design, execution and management of campaigns, and it also includes marketing event planning.
- **Support tracking.** The basic support tracking features include the ability to track the history of support requests from inception to resolution, including routing, ownership, escalations and transfers. It also includes integration with phone, electronic communication systems and the provision of customer database to track service contracts.
- **Field service.** Field service employs a mobile workforce and its tools allow users to communicate through wireless communications.
- **Knowledge base.** Knowledge base functionality is useful in all areas of customer-focused functions. There are two types of functionality. The first one is the ability to expose the knowledge base to the users through search capabilities. The second functionality is the ability to support the creation and maintenance of documents.
- **Customer portal.** Web-based customer access to the CRM systems is an absolute requirement. Customer portals and the functionality around them are sometimes called eCRM.

- **Analytics.** One of the benefits of CRM is an improved ability to view and analyze customer-related activities. Analytics have become big business and are often sold separately as a value-added option.

Today customers converse with an organization through a variety of channels which include telephone, fax, email, websites, kiosk and face-to-face exchanges. CRM manages the interaction and communication disruptions by managing every point of contact with the customer. Timm and Jones (2004) state that CRM software captures and consolidates customer information such as personal data, preferences, inquiry history and order information. The result is a comprehensive and seamless view of the customer. Complete customer information fosters completed conversations which in turn produce loyal customers.

CRM also plays an important role on the organization side. Key organization participants include sales, marketing, customer service and e-Commerce functions. The sales department looks to CRM to provide automated services for the sales force including ways to manage contract and leads. Marketing department uses CRM for cross-selling, targeted advertising and direct, targeted marketing. Customer service department depends on CRM to provide superior support and assistance, with all the data needed to fix problem. E-Commerce department uses CRM as the infrastructure for conducting business on the Web or for expanding their Web presence. Figure 2-6 illustrates how CRM works.



**Figure 2-6 How CRM Works (Adapted from Timm and Jones, 2004)**

## 2.2. IT Services

In order to develop CRM system for IT Service Company it is useful to specifically look into the area of IT services. This is because IT is changing rapidly and is becoming more service-oriented. The service culture, invented by helpdesk is now being inculcated into other processes and functions for instance procurements, application maintenance and infrastructure management.

### 2.2.1 IT Services Culture

Generally in any organizations, the IT department is a section that serves the information and communication needs of the business. Its primary focus is technology and its people are largely engineers. Today however, there is another way of seeing the IT group that is as a

business in itself rather than as a functional department. Bruton (2004) claims that IT has everything any business would have:

- A market (the userbase)
- Untapped opportunities within that market (use of ‘vertical’ applications with imported user support, new business needs, new versions of technologies etc.)
- A set of products and services
- A production line (the various end-to-end services and processes that produce them)
- Resources (staff, skills, technology) to produce those services
- Identifiable cost of production

For IT services, the way ‘service’ is delivered, the parameters surrounding it and associated limitations of authority of the service operative have to be well-defined as the product itself. This means that just like the product and process, IT service has to be designed and not just left to the staff in the vain hope that their ‘niceness’ will produce high levels of customer satisfaction.

### **2.2.2 IT Delivery Process**

In order to view IT services as a business, a business plan based upon a detailed consideration of the market is needed. Figure 2-7 shows the steps to go through in the creation, delivery and assessment of the IT service ‘factory’.

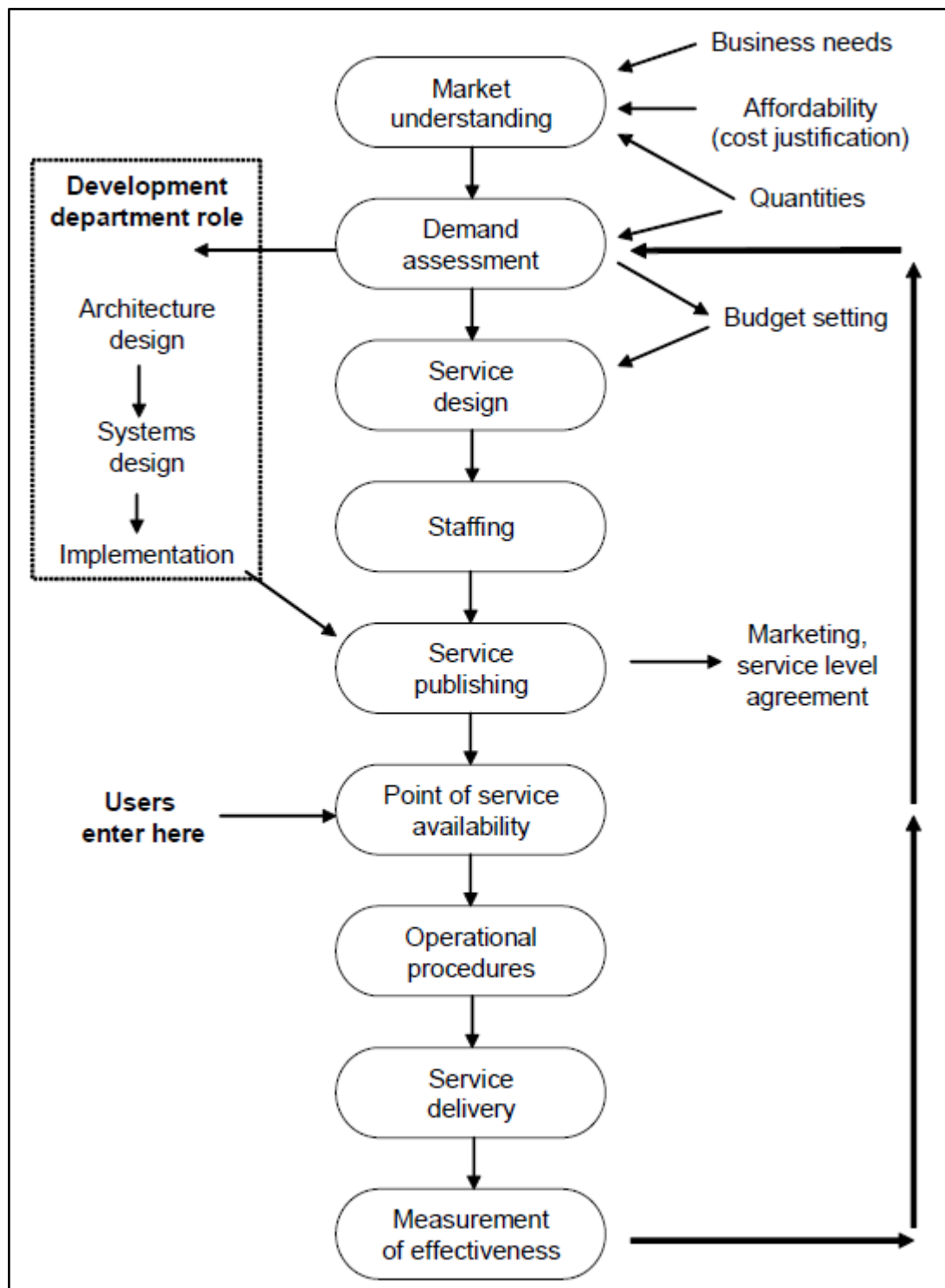


Figure 2-7 IT Delivery Process (Adapted from Bruton, 2004)



### 2.2.3 Types of IT Services

Based on the market demand, Bruton (2004) identifies the types of IT Services needed. The table below lists all the IT services and their descriptions.

**Table 2-5 Types of IT Services**

No.	Service	Descriptions
1	Account Management	Strategic representation at management level between user group and IT services
2	Antivirus	Protect users from attacks by malicious software
3	Applications maintenance	Upgrade and repairs to existing in-house business software to ensure continuing match to changing business needs
4	Archival	Offline data storage and retrieval
5	Business continuity	Disaster recovery
6	Change requests	Receipt, recording and processing of changes to any IT system or process
7	Computer operations	Management and provision of central processing
8	Consultancy	Assistance with choosing IT
9	Data conversion and transfer	Transfer of data between formats and processors
10	Environmental	Assistance with preparing the physical features of the desk environment for computing and communications tools

11	External support standards management	Provision and management of performance standards for external IT support suppliers
12	Financial reports	Information on financial implications of IT services activity
13	Hardware maintenance	Replacement and repair of faulty hardware
14	Helpdesk	Reporting point for user enquiries
15	Infrastructure	Provision of corporate data communications, storage and processing machinery
16	Installations	Making new hardware and software available for use at the usual point of use
17	Loans	Provision of temporary equipments
18	Management reports	Periodic documented management information
19	Moves	Changing the location of equipment
20	Network connection	Account on corporate computer network
21	Problem solving	Resolving computer problems reported to ITS by users
22	Procurement	Acquisition of IT equipment
23	Projects	Ad hoc projects
24	Remote resolution	Resolution of problems by remote control
25	Telephone connection	Account on corporate telephone private automatic branch exchange (PABX)
26	Training	Provision of computer usage training

27	Usage support horizontal applications	Assistance with use of standard applications as provided by network connection service
28	Usage support vertical applications	Assistance with use of business and specialist applications
29	User applications development	Provision of resource for writing new, ad hoc systems for specific user needs for desktop, laptop and palmtop processor
30	User performance monitoring	Feedback to line managers on employee use of helpdesk
31	Videoconferencing	Provision of videoconferencing facilities

### 3. Functional Requirements and Methodology

Generally, a methodology is a codified set of recommended practices. Methodology can also be defined as organized, documented set of procedures and guidelines that describes how something will be done. Methodology includes the frameworks, techniques, methods, patterns and procedures used to accomplish a set of goals and objectives. This chapter provides a clear guideline on how the project's goals and objectives shall be achieved.

For research purposes, CRM application is developed and named ITManagerCRM. ITManagerCRM from its name will be focused on planning organizing and delivering IT Services.

ITManagerCRM is web-based application. Following chapters will describe how application is developed.

#### 3.1. Project Methodology

Developing strategy of ITManagerCRM is illustrated in Figure 4-1. The project solution roadmap consists of 5 stages which are the strategy, requirements, design, development and implementation. Blue colored boxes in Figure 4-1 reflect the researcher's project scope.

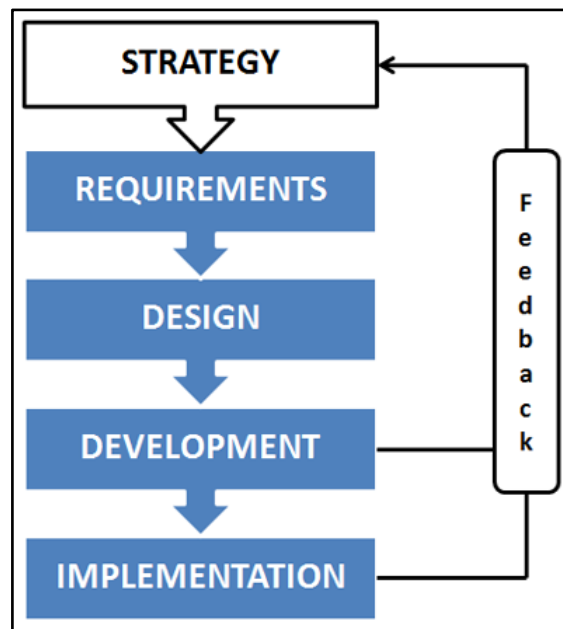


Figure 3-1 Project Solution Roadmap

Based on the solution roadmap in Figure 4-1, CRM application is developed and it comprises of 4 phases. All these phases with their key initiatives are described in the subsequent sections of this chapter. And each phase will be named optional as follow:

- **Phase 1** – Project Strategy
- **Phase 2** – Project Requirements
- **Phase 3** – Project Design
- **Phase 4** – Project Development
- **Phase 5** – Project Implementation.

### **3.1.1 Project Strategy**

The first phase of the operational framework is strategy. The main purpose of this phase is to define the goals, priorities and high-level business needs of the organization. Strategy allows the researcher to take the small steps that are more likely to be successful while ensuring that each one takes her in the direction of the ultimate goal. Strategy also allows the researcher to identify what is most important, get started, have a success and benefit from what is already built in ITManagerCRM. Another vital outcome from this phase is to get widespread participation, input, visibility, understanding and support for the long-term strategy of ITManagerCRM and immediate priorities of the project.

The strategy and planning phase of CRM life cycle encompasses surveys of key internal and external interested parts. It produces a set of documents or blueprints.

### **3.1.2 Project Requirements**

The focus of phase 2 is the analysis of all the elements required to meet the project objectives. The main purpose is to identify business needs of ITManagerCRM for information, process, technology and people. Information is the raw material of CRM. Customer-centered processes are the product of CRM. Technology is the machinery that enables CRM to work. And people are the power supply of CRM.

### 3.1.3 Project Design

When the requirements have been determined, the project moves into the third phase that is the design phase.

ITManagerCRM will be developed based on the theories and methodologies obtained during the literature review, coupled with the findings derived from the requirements analysis. The literature review has provided the researcher with detail concepts of customer, CRM and IT Services.

The focus of Phase 2 is the analysis, design and construction of all the infrastructure elements required to meet the project objective. Integration occurs during the transition to Phase 3.

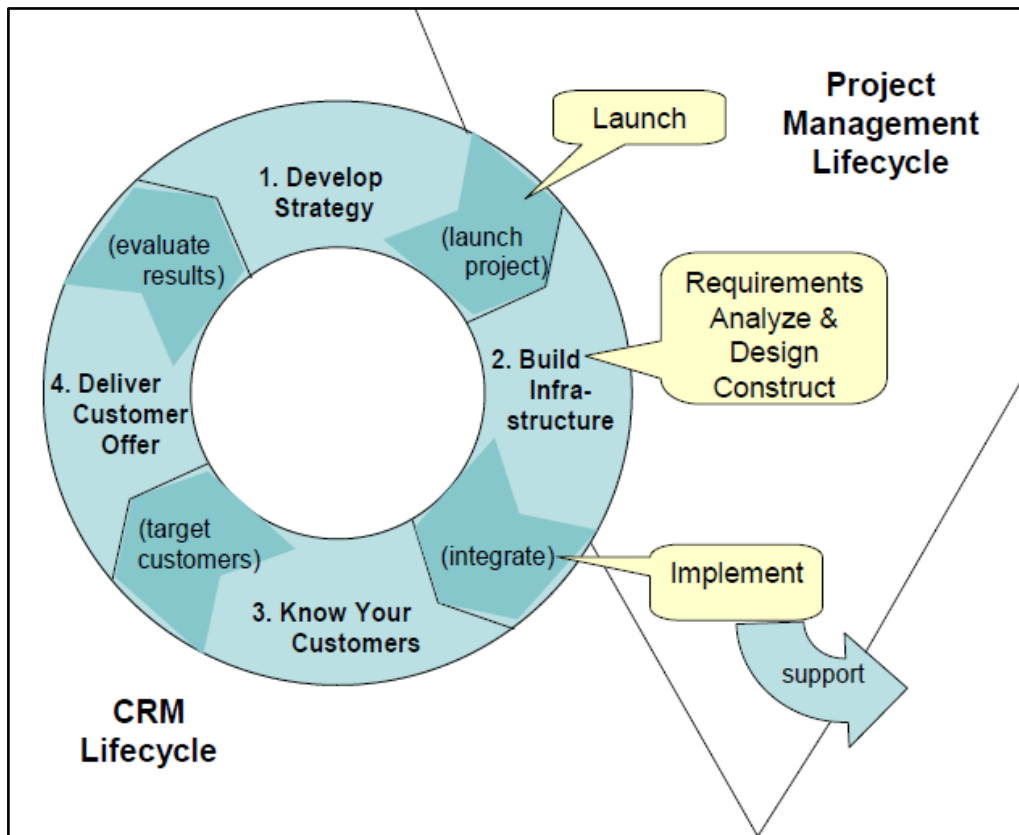
According to Figure 6-2 there are four phases in the CRM Lifecycle with four transition steps connecting them.

**Phase 1** begins by creating a vision and a strategy so that the organizations know what they want to achieve. The process also helps them understand their business, priorities and competitive position so that they can pick the best place to begin.

**Phase 2** involves creating the supporting infrastructure while remembering that CRM is more than just technology. After necessary work has been done internally, organizations may now take the new capability or campaign to their customers.

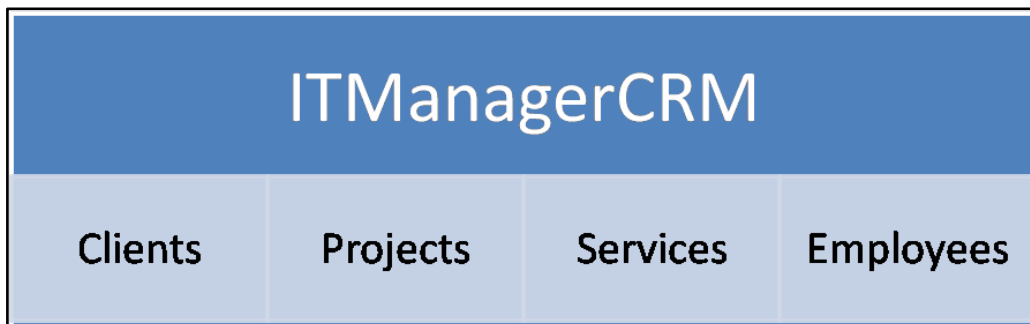
**Phase 3** starts by identifying specific customers to include in the new capability.

The last phase which is **Phase 4** is where organizations will deliver the benefit to these targeted customers.



**Figure 3-2 ITManagerCRM Lifecycle (Adapted from Kincaid, 2003)**

Based on the findings elements for ITManagerCRM are identified. The CRM will be a personalized, Web-based application that markets to, and service customers across multiple channels. The personalization is accessible through a password and username. Four elements are identified for the CRM which is illustrated in Figure 4-3.



**Figure 3-3 CRM Elements**

The following Table 4-1 shows every elements of CRM in details:

**Table 3-1 CRM Actors features**

CRM Elements	Actor	Features
Clients	Client	Manage personal information
	Employee	
	Administrator	Manage clients
Projects	Client	
	Employee	View personal projects
	Administrator	Manage projects
Services	Client	View service catalog Manage personal services
	Employee	
	Administrator	Manage services
Employees	Client	
	Employee	Manage personal information
	Administrator	Manage employees

### 3.1.4 Project Development

Once Phase 3 is completed, the development phase for CRM will commence. As technology is the enabler of CRM, this phase starts by acquiring hardware and software needed to develop the CRM.

ITManagerCRM was built on .NET environment and the following hardware and software required (Microsoft, 2010).

#### 1. Hardware requirements

- PC that has a 1.6GHz or faster processor
- 1 GB (32 Bit) or 2 GB (64 Bit) RAM
- 3GB of available hard disk space after OS installed
- 5400 RPM hard disk drive



- DirectX 9 capable video card running at 1024x768 or higher-resolution display

## 2. Software requirements

- Supported operation systems
  - Windows 7
  - Windows Vista
  - Windows XP
  - Windows Server 2003
  - Windows Server 2008
- Supported Web Servers
  - Internet Information Service (IIS) 5.1 or above
  - ASP.NET 4.0
- Supported Databases
  - MSSQL 2005 or above
- Supported browsers
  - Microsoft Internet Explorer 6 and above
  - Mozilla Firefox 2.0 and above
  - Google Chrome 1.x
  - Apple Safari 2.x
  - Visual Studio 2010 or above

## 4. Software Development and Implementation

ITManagerCRM will provide standard activities for ICT service organization to achieve good customer relationships by implementing CRM concepts and integrating basic necessary components.

### 4.1. CRM Design and Development

#### 4.1.1 Develop a Strategy

The strategy and planning phase of CRM life cycle encompasses surveys of key internal and external interested parts. It produces a set of documents or blueprints.

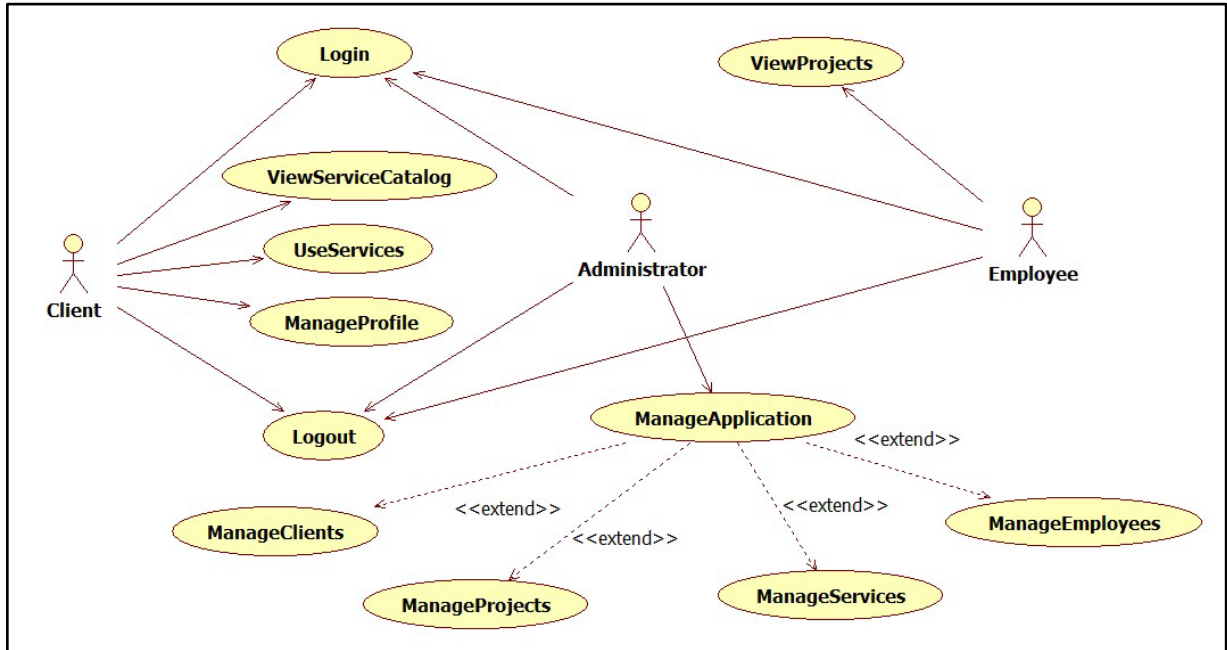
Table 5-1 shows the main steps involved and the purposes:

**Table 4-1 Steps and purposes for strategy development**

<b>Step</b>	<b>Purpose</b>
Data Collection	<ul style="list-style-type: none"><li>• Ensure that the CRM application is aligned with company strategy</li><li>• Discover what customers think about your performance. What do they want more of?</li></ul>
Assess Findings	<ul style="list-style-type: none"><li>• Identify business strategies, risks, and opportunities that will influence your CRM</li><li>• Identify gaps between the goal and today's reality</li></ul>
Create Proposal	<ul style="list-style-type: none"><li>• Define a common vision and language about what CRM is for your company</li><li>• Ensure that key constituents understand and support the strategy</li></ul>
Launch Project	<ul style="list-style-type: none"><li>• Select the best project to tackle</li><li>• Determine scope</li><li>• Determine schedule and resources</li></ul>

### 4.1.2 Use-Case Model

In order to represent interactions between users and system use-case model is used. And it helps to capture the goal of the users and the responsibility of the CRM to its users. It consists of a collection of all use cases and through a graphic notation termed as the use-case diagram, the interested parts and the CRM functionality is displayed as illustrated in Figure 5-1.



**Figure 4-1 Use-case diagram for ITManagerCRM**

### 4.1.3 Use-case Scenarios

The use-case scenarios or descriptions for each use case in the conceptual design of CRM are listed below:

#### 1. Login Use Case

Use Case Name	Login
Description:	This use case describes how a user logs into the CRM
Actor:	Registered client, employee, administrator
Pre-Condition:	User has been registered. The CRM homepage is loaded and displayed.
Normal Flow:	1) User enters Username and Password at the Login Form.

2) User clicks on the Login button.  
3) The CRM homepage will be redisplayed.  
Post-Condition: User is logged into the CRM

## **2. ViewServiceCatalog Use Case**

Use Case Name ViewServiceCatalog  
Description: This use case describes how a client views the service catalog.  
Actor: Client  
Pre-Condition: The CRM homepage is loaded and displayed.  
Normal Flow: 1) Client clicks 'Services' at the Main Menu.  
2) Service Catalog is displayed.  
3) User browses through the list of services.  
Post-Condition: null

## **3. UseServices Use Case**

Use Case Name UseServices  
Description: This use case describes how a client views and selects the services offered.  
Actor: Registered Client  
Pre-Condition: User is logged into the system.  
The CRM homepage is loaded and displayed.  
Normal Flow: 1) Client clicks 'Services' at the Main Menu.  
2) List of services is displayed.  
3) Client makes a selection by clicking on a service.  
Post-Condition: User is redirected to the desired option

## **4. ManageProfile Use Case**

Use Case Name ManageProfile  
Description: This use case describes how a registered client manages his/her profile.  
Actor: Registered Client  
Pre-Condition: User is logged into the system.  
The CRM homepage is loaded and displayed.

Normal Flow: 1) Client clicks 'Manage Your Profile' at the User Menu.  
2) Client details form is displayed.  
3) Client edits his/her profile by entering the details.  
4) Client clicks the Update button.

Post-Condition: Client profile is updated

## 5. Logout Use Case

Use Case Name Logout

Description: This use case describes how a registered user logs out of the CRM.

Actor: Registered client, employee, administrator

Pre-Condition: User is logged into the system.  
The CRM homepage is loaded and displayed.

Normal Flow: 1) User clicks 'Logout' at the User Menu.  
2) A confirmation page to logout is displayed.  
3) User clicks the Logout button.  
4) User is logged out from CRM.

Post-Condition: The CRM homepage is loaded and displayed.

## 6. ManageApplication

Use Case Name ManageApplication

Description: This use case describes how an administrator manages the CRM.

Actor: Administrator

Pre-Condition: The CRM homepage is loaded and displayed.

Normal Flow: 1) Administrator selects 'Administrator' at the Login Form.  
2) Administrator logs into CRM admin area.  
4) Administrator selects one of the extended options from the main menu to manage and update CRM.  
5) Administrator logs out from the admin area.

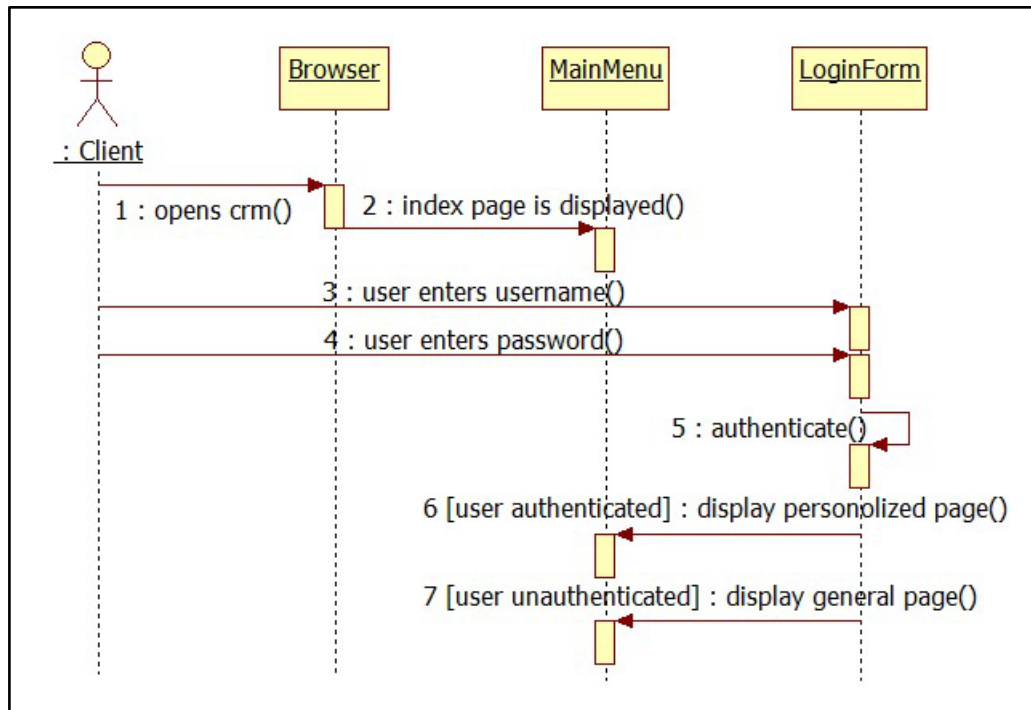
Post-Condition: The CRM homepage is loaded and displayed.

## 7. ViewProjects Use Case

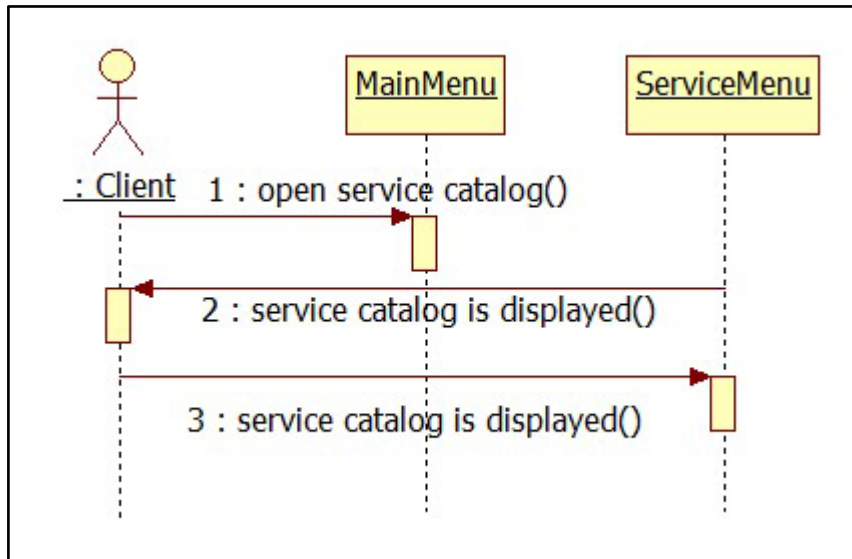
Use Case Name	ViewProjects
Description:	This use case describes how an employee views his/her projects.
Actor:	Employee
Pre-Condition:	The CRM homepage is loaded and displayed.
Normal Flow:	1) Employee selects 'Employee' at the Login Form. 2) Employee logs into CRM employee area. 4) Employee selects option from the projects to manage and update 5) Employee logouts from the employee area.
Post-Condition:	The CRM homepage is loaded and displayed.

### 4.1.4 Sequence Diagrams

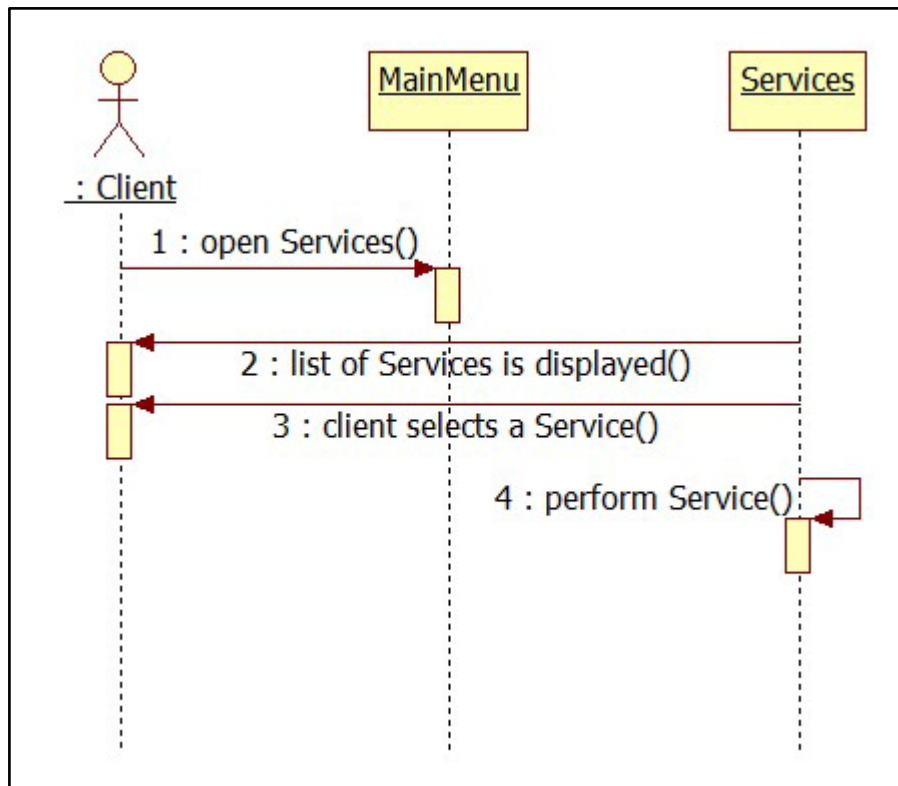
Sequence diagrams are designed to provide an easy and intuitive way of describing the behavior of CRM by viewing the interaction between the CRM and its environment. The following figures show the sequence diagrams of CRM application.



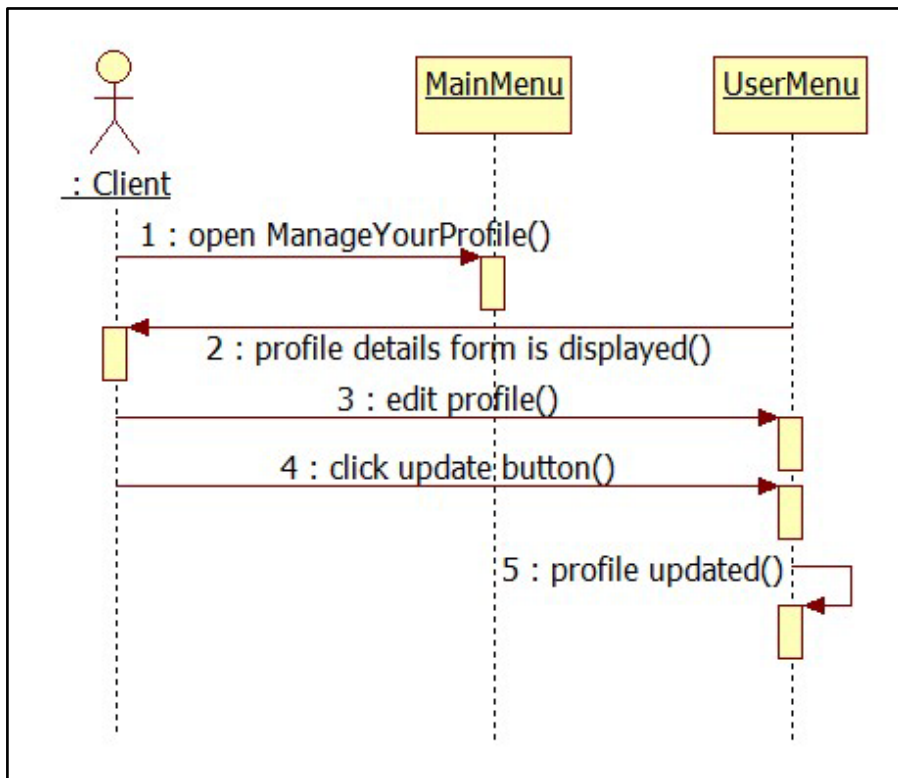
**Figure 4-2 Login Sequence Diagram**



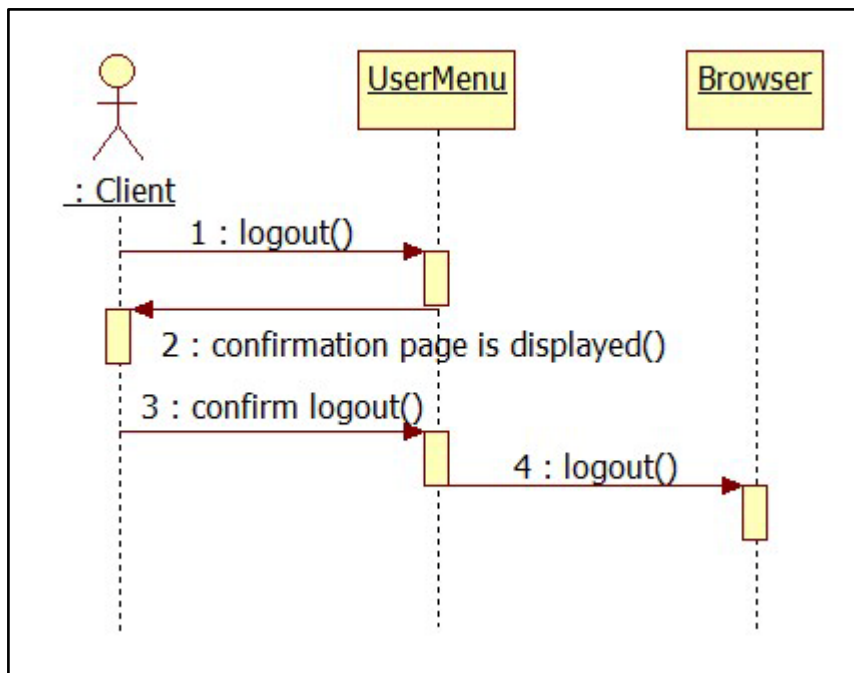
**Figure 4-3 ViewServiceCatalog Sequence Diagram**



**Figure 4-4 UseServices Sequence Diagram**

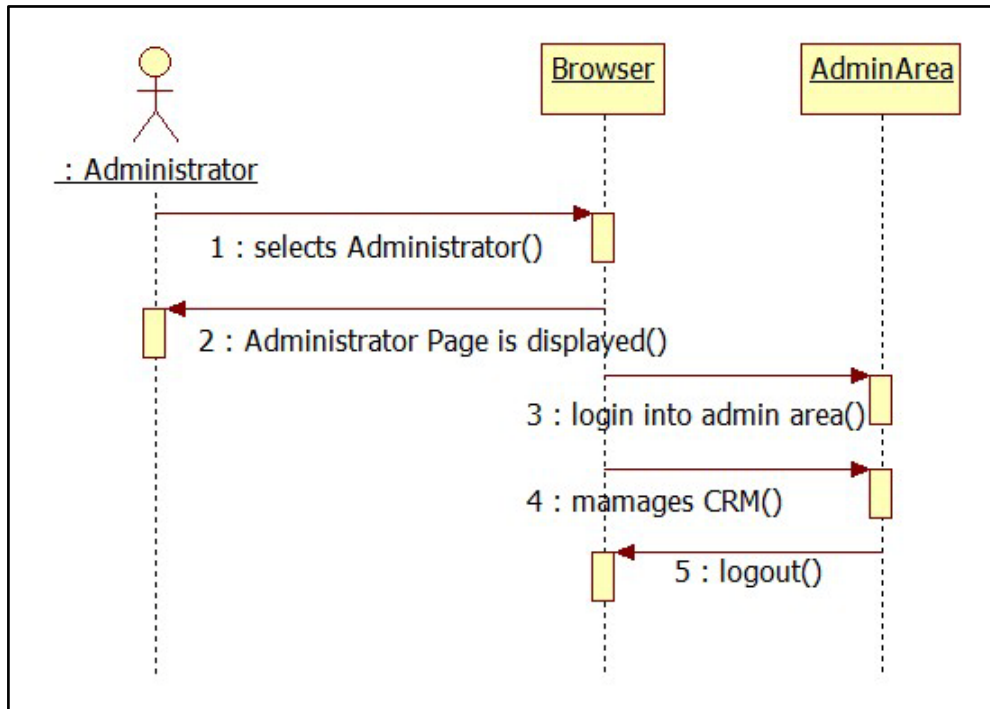


**Figure 4-5 ManageProfile Sequence Diagram**

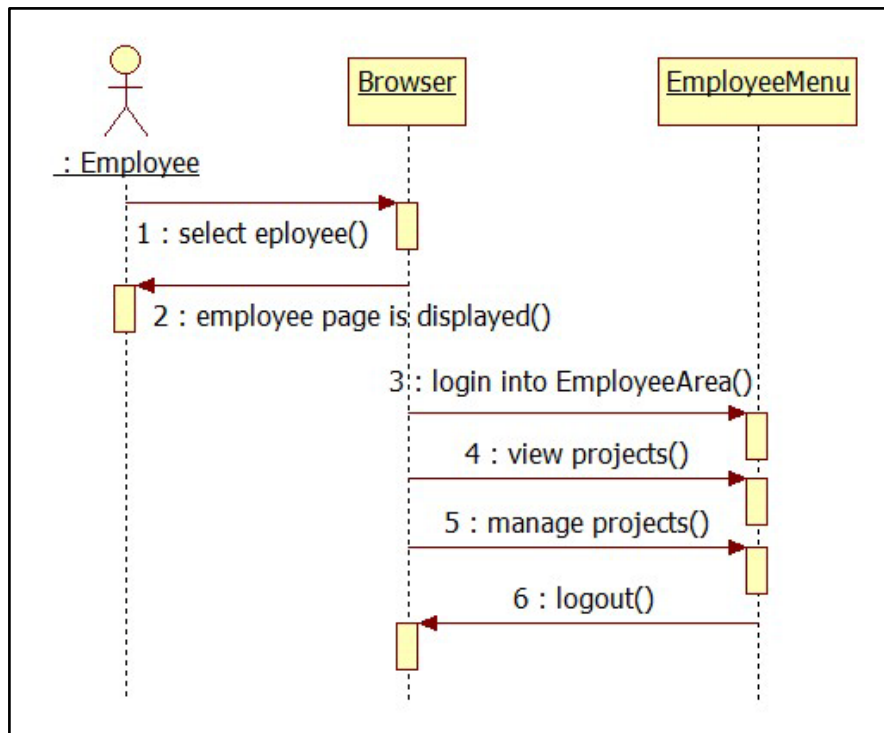


**Figure 4-6 Logout Sequence Diagram**





**Figure 4-7 ManageApplication Sequence Diagram**



**Figure 4-8 ViewProjects Sequence Diagram**

Based on the conceptual design, the CRM is developed and the user interfaces are designed.

#### 4.1.5 ADO.NET Entity Framework diagram

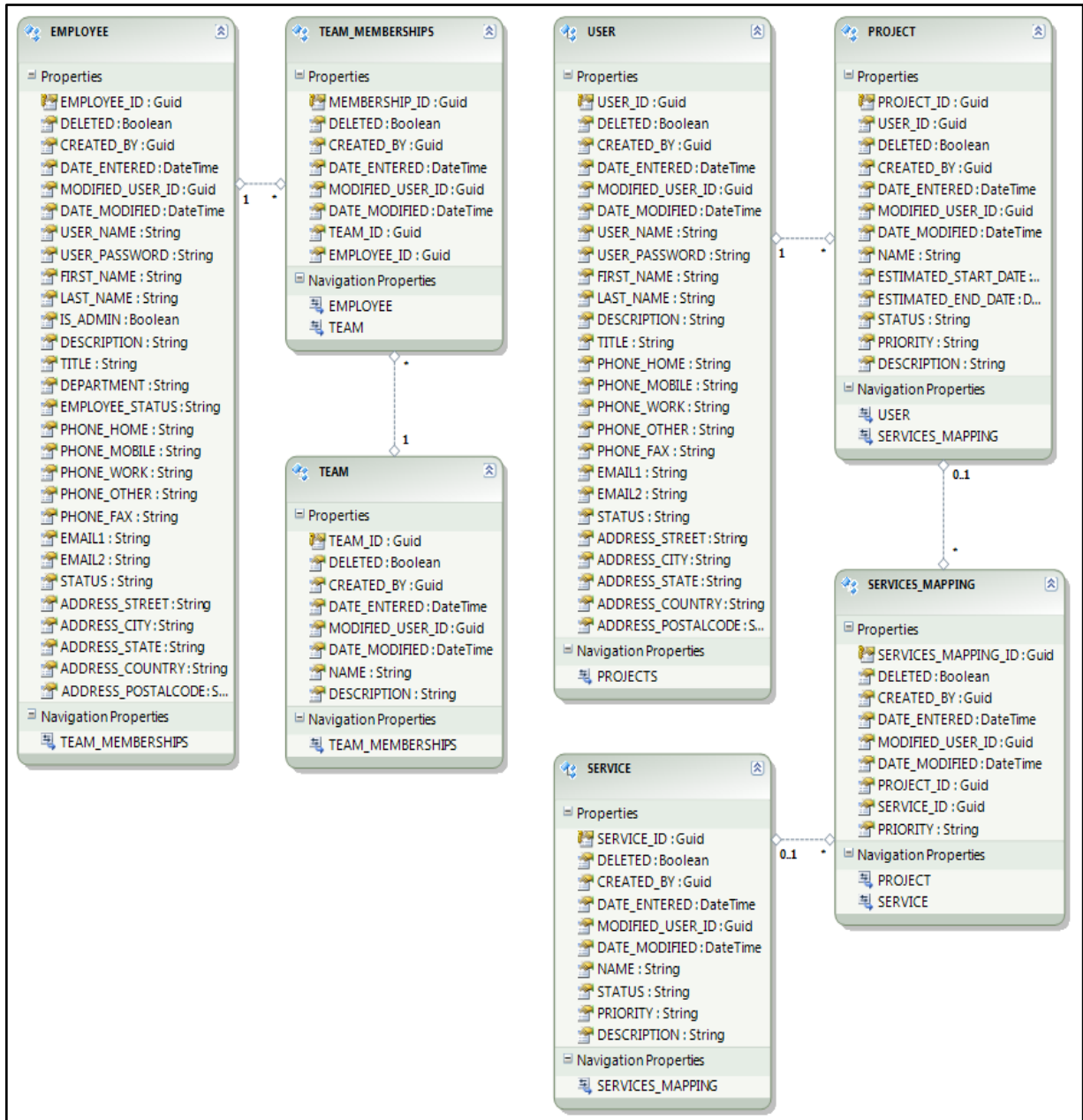


Figure 4-9 ADO.NET Entity Framework diagram for ITManagerCRM

## **4.2. CRM Implementation**

This chapter describes how the end products of this projects as developed by the researcher will be implemented.

ITManagerCRM will undergo certain implementation steps which will be explained in the following sections.

- **Assign personnel to be in charge of the CRM**

Upon submission of the CRM, company must take immediate action by assigning personnel to be in charge of the CRM and to perform necessary steps prior to CRM launch

- **CRM Content and Features Enhancement**

Company personnel (administrator) verify CRM contents and enhance or add insufficient information. All features within the CRM including services are enhanced to better serve customers and company needs.

- **CRM Launched**

The new CRM is uploaded and launched.

- **Analyze results and Feedbacks**

This analysis includes the analysis of services, feedback, poll and online survey. By looking at the customers' participation and comments, company can measure and review its services from time to time.

- **Review & Update**

Contents of the CRM must be updated regularly. Company should finally decide on the duration to conduct a review of its CRM effectiveness. Administrator and personnel in charge should first gather all necessary information, statistics and analysis so that the CRM review can take place and further improvements can be made to the current CRM.

## **5. Conclusion**

During analysis of literature review and development of CRM application for small IT Company the researcher has gain very good achievement, knowledge and experience and awareness towards the security measures that needs to be taken while trying to implement any CRM applications. And further my knowledge on N-tier application development has improved a lot.

The development of the CRM application for small IT Company was cost effective, more personalized and easily updatable compared to buying CRM from IT Service Companies. Therefore the researcher recommend for small companies to develop their own CRM

## **6. References**

1. Don Peppers, Martha Rogers. *Managing Customer Relationships: A Strategic Framework*. 2nd edition. Wiley, 2011. 512 p. ISBN 9780470423479
2. Francis Buttle. *Customer Relationship Management*. Butterworth-Heinemann, 2005. 384 p. ISBN 075065502X
3. Francoise Tourniaire. *Just Enough CRM*. Prentice Hall PTR, 2003. 400 p. ISBN 0131010174
4. Gartner, Inc. *What's 'Hot' in CRM Applications in 2009*. Gartner, Inc., 2009
5. Kincaid, J. W. *Customer Relationship Management: Getting It Right*. Prentice Hall, 2003. 512 p. ISBN 9780130352118
6. Matthew MacDonald, Mario Szpuszta *Pro ASP.NET 3.5 in C# 2008*. 2nd edition. Apress, 2007. 1498 p. ISBN 1590598938
7. Noel Bruton. *Managing the IT Services Process*. 1st edition. Butterworth-Heinemann, 2004. 256 p. ISBN 9780750657235
8. Paul Greenberg. *CRM at the Speed of Light: Capturing and Keeping Customers in Internet Real Time*. 1st edition. Osborne/McGraw-Hill, 2001. 360 p. ISBN 0072127821
9. Timm, P. R., Jones, C. G. (2004). *Technology and Customer Service: Profitable Relationship Building*. Prentice Hall, 2004. 208 p. ISBN 0130989908

### **Internet sources**

1. [On-line]. [Accessed on 2011-04-08]. [<http://searchcrm.techtarget.com/feature/CRM-strategy-checklist-Planning-for-CRM-and-customer-service-success?offer=brieffcaseCRM>]
2. [On-line]. [Accessed on 2011-04-08]. [<http://www.customerservicepoint.com/crm-system.html>]
3. [On-line]. [Accessed on 2011-04-08]. [<http://www.destinationcrm.com/Articles/CRM-News/Daily-News/What-Is-CRM-46033.aspx>]
4. [On-line]. [Accessed on 2011-04-08]. [<http://www.destinationcrm.com/Articles/CRM-News/Daily-News/What-Is-CRM-46033.aspx>]
5. [On-line]. [Accessed on 2011-04-08]. [<http://www.microsoft.com/visualstudio/en-us/products/2010-editions/ultimate/system-requirements>]