

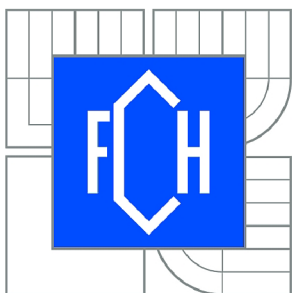

VYSOKÉ UČENÍ TECHNICKÉ V BRNĚ

BRNO UNIVERSITY OF TECHNOLOGY



FAKULTA CHEMICKÁ

CENTRUM MATERIÁLOVÉHO VÝZKUMU

FACULTY OF CHEMISTRY

MATERIALS RESEARCH CENTRE

METHODOLOGY FOR EXPERIMENTAL STUDY ON THE RELEASE OF HUMIC ACIDS FROM HYDROGEL APPLICATION FORMS.

NÁVRH A OPTIMALIZACE METODY EXPERIMENTÁLNÍHO STUDIA UVOLŇOVÁNÍ
HUMINOVÝCH LÁTEK Z GELOVÝCH APLIKAČNÍCH FOREM.

BAKALÁŘSKÁ PRÁCE

BACHELOR'S THESIS

AUTOR PRÁCE

AUTHOR

VERONIKA PALANOVÁ

VEDOUCÍ PRÁCE

SUPERVISOR

Ing. PETR SEDLÁČEK, Ph.D.

BRNO 2014



Vysoké učení technické v Brně
Fakulta chemická
Purkyňova 464/118, 61200 Brno 12

Zadání bakalářské práce

Číslo bakalářské práce:	FCH-BAK0804/2013	Akademický rok: 2013/2014
Ústav:	Centrum materiálového výzkumu	
Student(ka):	Veronika Palanová	
Studijní program:	Chemie a chemické technologie (B2801)	
Studijní obor:	Chemie pro medicínské aplikace (2808R031)	
Vedoucí práce	Ing. Petr Sedláček, Ph.D.	
Konzultanti:		

Název bakalářské práce:

Návrh a optimalizace metody experimentálního studia uvolňování huminových látek z gelových aplikačních forem.

Zadání bakalářské práce:

- 1) Vypracovat literární rešerši zaměřenou na metody laboratorního studia uvolňování aktivních látek s hydrogelových nosičových systémů.
- 2) Na základě literární rešerše navrhnout a optimalizovat metodu studia uvolňování huminových látek z gelových matric.

Termín odevzdání bakalářské práce: 23.5.2014

Bakalářská práce se odevzdává v děkanem stanoveném počtu exemplářů na sekretariát ústavu a v elektronické formě vedoucímu bakalářské práce. Toto zadání je přílohou bakalářské práce.

Veronika Palanová
Student(ka)

Ing. Petr Sedláček, Ph.D.
Vedoucí práce

prof. Ing. Miloslav Pekař, CSc.
Ředitel ústavu

V Brně, dne 31.1.2014

prof. Ing. Jaromír Havlica, DrSc.
Děkan fakulty

ABSTRAKT

Hlavnou náplňou bakalárskej práce bolo navrhnuť a optimalizovať metódu experimentálneho štúdia uvoľňovania huminovej látky z gelových matric, ktoré boli vytvorené pomocou bežných kozmetických a farmaceutických zahusťujúcich látok. Pre štúdium uvoľňovania tejto aktívnej látky bola zvolená difúzna aparátúra vo vertikálnom usporiadaní, tzv. Francova cela. Výluhy gelových vzoriek boli podrobené spektrofotometrickým meraniam. Vzniklé interakcie medzi roztokmi lignohumátu a rôznych typov zahusťujúcich látok boli experimentálne stanovené. Celý proces optimalizácie metódy pre uvoľňovanie huminovej látky z gelových foriem bol diskutovaný.

ABSTRACT

The bachelor's thesis focuses on the optimization of a method of experimental study on a release of the humic substance as an active agent from the hydrogel matrix formed by using different thickening agents. The utilization of vertical diffusion cell, so called Franz's cell, was tested in order to examine the gel samples. All the samples had also been analyzed by spectrophotometric measurements. The interactions between the lignohumate solutions and the thickeners were determined. The optimization of the release processes within the gel samples was discussed.

KLÍČOVÁ SLOVA

humínové látky, hydrogel, difúzia, Francova cela, uvoľňovanie aktívnych látok

KEYWORDS

humic substances, hydrogel, diffusion, Franz's cell, drug release

PALANOVÁ, V. *Návrh a optimalizace metody experimentálního studia uvolňování huminových látek z gelových aplikačních forem*. Brno: Vysoké učení technické v Brně, Fakulta chemická, 2014. 48 s. Vedoucí bakalářské práce Ing. Petr Sedláček, Ph.D.

DECLARATION

I declare that the bachelor's thesis has been worked out by myself and that all the quotations from the used literary sources are accurate and complete. The content of the bachelor's thesis is the property of the Faculty of Chemistry of Brno University of Technology and all commercial uses are allowed only if approved by both the supervisor and the dean of the Faculty of Chemistry, BUT.

.....

student's signature

ACKNOWLEDGEMENT

Firstly, I would like to thank my supervisor Dr. Petr Sedláček for his willingness to help me to solve the obstacles formed during the research and to provide me new scientific information. I would like to thank my family for their support and love. And at the end, I would like to thank my schoolmates who made my research easier and funnier.

CONTENT

1	Introduction	7
2	Theoretical part	8
2.1	Humic substances	8
2.1.1	Well-known facts	8
2.1.2	Structure and composition of humic substances	8
2.1.3	Humic substances and their conventional applications	9
2.2	Hydrogels	10
2.2.1	Structure of hydrogels	10
2.2.2	The gel formation	11
2.2.3	The gel matrix – traditional ingredients	11
2.2.4	Diffusion methods	13
2.2.5	Drug controlled release systems.....	14
2.2.5.1	Diffusion-controlled delivery systems	15
2.2.5.2	Swelling-controlled delivery systems	16
2.2.5.3	Chemically-controlled delivery systems	17
2.2.5.4	Micro/nanoscaled delivery systems	17
3	Current pathways	18
3.1.1	Medical applications of humic substances	18
3.1.2	Skin and hydrogels	18
3.1.3	Up-to-date research	19
3.1.3.1	Humic substances in medicine.....	19
3.1.3.2	Modern trends in hydrogel – based delivery systems	20
4	Experimental part	23
4.1	Chemicals and devices.....	23
4.2	Thickening agents.....	23
4.3	Preparation of stock solutions of Lignohumate	23
4.4	Preparation of neutralizing agent.....	23
4.5	Preparation of receptor solution	24
4.6	Preparation of gel samples.....	24
4.6.1	Illustration – 2% Polygel CA with 1% solution of Lignohumate	24
4.7	Methods of characterization of humic substances release from the hydrogels	24
4.7.1	Diffusion experiments	24
4.7.2	UV–VIS spectroscopy.....	25

4.7.2.1	Calibration curve.....	25
5	Discussion of results	26
5.1	Characterization of humic substances release from the hydrogels.....	26
5.1.1	Diffusion experiments – the method optimalization.....	26
5.1.2	UV – VIS spectroscopy.....	29
5.1.2.1	Demonstrational Sample: 2% Polygel CA with 1% LH solution and with 5% LH solution	30
6	Conclusion.....	35
7	References	36
8	List of symbols	38
9	List of abbreviations.....	39
10	Attachments	40
10.1	UV – VIS spectra	40
10.2	Different types of diffusion within different gel samples.....	41
10.3	Calibration curve.....	48

1 INTRODUCTION

What does usually come on our minds when the words humic acids appear as a topic of some casual conversation? Non-chemist people would probably imagine that we are talking about a soil that is used as a ground for agricultural crops or housewife's flowers. But there is a bigger deal than it seems to be?!

It is known that humic substances form a part of natural organic matter and possess exceptional characteristics that contribute to their spread applications. Instead of the demand in agriculture's branch, humic substances are also used in biomedical applications and cosmetics. The properties of humic substances which make them interesting for many investigators have still been studied in numerous research works.

Obviously, the polymeric crosslinked networks which are able to hold the water in its structure, so called hydrogels, are also the one of the 'hottest' topics in the present applied research. Their capacity to hold a specific amount of water, to carry specialized active agents, to maintain the drug release, to take part in healing processes – this is only the brief sum of hydrogel's characteristics which are well – proved and which correspond to their widespread applications.

Hydrogels as controlled drug – release and delivery systems have been studied in many diffusion experiments and this was the reason why they were also selected for this bachelor's thesis. The figure shows that the interest of release processes of active molecules from hydrogels has been constantly increasing in the last years.

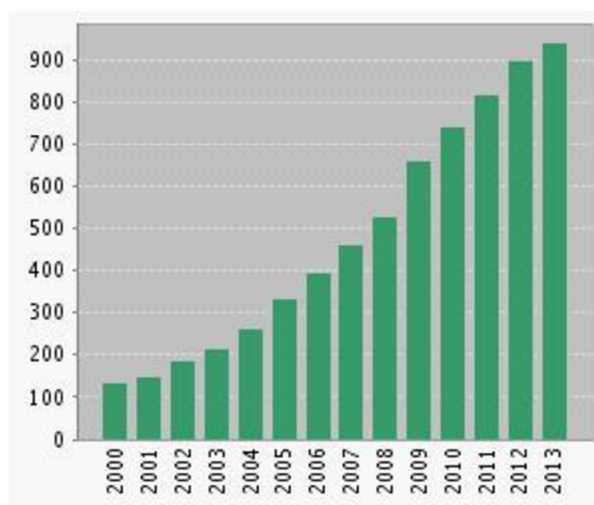

Figure 1. *Published papers (hydrogel – release) in the last ten years [29]*

The aim of this bachelor's thesis was to suggest and optimize the method of the release of an active agent (humic substance) from the gel matrix formed by using different thickening agents and then to examine the solution of released active molecule by selected analytical method.

2 THEORETICAL PART

2.1 HUMIC SUBSTANCES

2.1.1 Well-known facts

Humic substances can be described as products that are produced by biological decomposition of a dead biomass, phenolic compounds that undergo synthetic oxidation or polymers that are formed during roasting processes. These natural organic compounds can be found in many different places such as soils, water, peat and coal as well.

Humic substances are divided into three fractions, these are humic acids, fulvic acids and humin. This division is derived from acid-base effects of humic substances and their behaviour in acid or base solutions. Humic acids are soluble in alkali solutions, on the other hand, their solubility decreases with decreasing pH. It means that they are not soluble in water solutions with the value of pH less than two. Fulvic acids dissolve both in acids and bases, it does not matter the pH of the solution. Third category is humin, which can be dissolved neither in water nor in alkali solutions [1].

These organic compounds can also differ in a pigmentation. It is caused by distinct molecular weights of polymers, quantity of functional groups in each category and degree of polymerization. That is why the colour of humic acid is usually dark brown to black, fulvic acid yellow to yellow-brown and humin is black in colour [1].

Table 1. *Chemical properties of humic substances (modified from [1])*

	Humic substances (pigmented polymers)		
	Fulvic acids	Humic acids	Humin
Intensity of colour	→	→	→
Degree of polymerization	→	→	→
Molecular weight	→	→	→
Carbon content	→	→	→
Oxygen content	←	←	←
Exchange acidity	←	←	←
Degree of solubility	←	←	←

2.1.2 Structure and composition of humic substances

The basic elements that are included in the structure of humic substances are C, H, O and N, S. In fact, these elements are always presented regardless their origin and region or continent where they come from [2]. However, besides the importance of elemental contribution, the functional group composition provides the information about the chemical and structural properties of humic substances. Humic acids contain less functional groups (–COOH, phenolic –OH) that are of an acidic nature than the fulvic acids. When talking about oxygen as an element, this is incorporated in the nucleus and it is holded in its structure by ether and ester bonds [3]. There are many compounds which are involved in the humification processes, when the humic substance system is formed. For instance, amino acids, lignins, pectins or carbohydrates. All of these are holded

strongly together through different intermolecular forces such as donor-acceptor, hydrophilic, ionic or hydrophobic interactions [2].

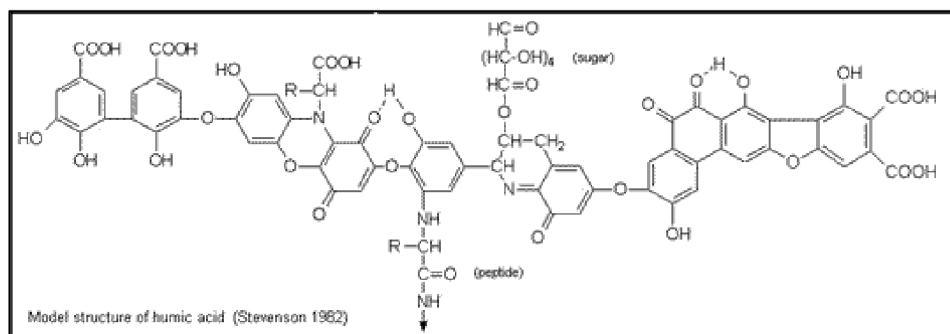

Figure 2. Historical model structure of humic acid by Stevenson [1]

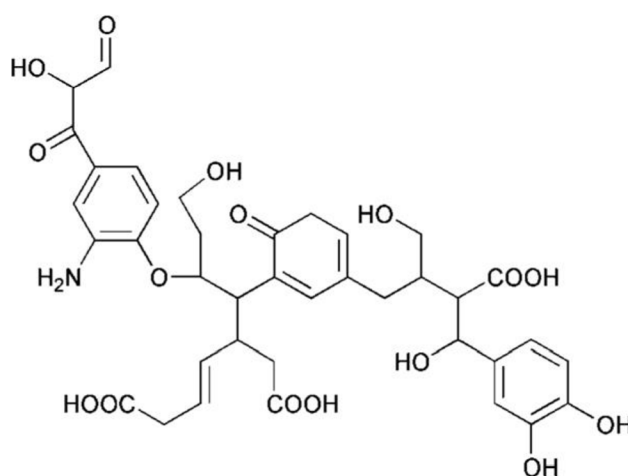

Figure 3. The Steelink model of humic acid monomer [4]

The above mentioned humification process includes numerous biochemical reactions. The theories that explain the formation of humic substances differ mainly in the starting substrate and mechanism of its transformation. First theory describes this process as a product of depolymerization of biopolymers and the other one as a product of polymerization of small molecules which are released after the decomposition of biopolymers [3].

2.1.3 Humic substances and their conventional applications

It is said that the humic substances are all around us and this is the reason why they are practically used as a starting point of many applications in different industrial and non-industrial fields.

Humic substances are commonly used in agriculture as an important part of soils. They are able to influence the physical properties of the soils, soil's productivity and quality. These complex substances can also influence soil fertility and its growth-promoting effects [2].

When talking about industrial applications, the humic substances are used as the additives to control the setting rate of concrete. Humic substances are also used in

production of plastics, in paper industry, as sources of synthetic hydrocarbons and fuel oils and also in food processing [2].

Humic substances also possess a great potential in biomedical applications. Apart from its utilization as fuel or other industry components, the humic substances are widely used as substrates for medical applications in a large scale. More detailed insight of the medical applications of humic substances is available on chapter 3.1.1.

2.2 HYDROGELS

2.2.1 Structure of hydrogels

Hydrogels are described as the crosslinked polymer networks that are swelling in water. Hydrogels have many properties that give them the water – retention characteristics. For instance, hydrophilic groups, such as amino; hydroxyl and carboxyl groups, are included in the polymer structure that give them a capacity to hold the water. The capacity of the hydrogel to hold the water in its structure is given by the number of hydrophilic groups. The higher the number of the hydrophilic groups, the higher the capacity to hold the water in the polymer structure will be. But on the other hand, when crosslinking density increases the stretchability of this three dimensional polymeric network decreases [5].

The cross links that are presented in the structure of hydrogel have chemical or physical nature. Chemical or permanent cross links are characterized by strong covalent bonds. Hydrogels that contain cross links formed physically (for example by ionic interactions or hydrogen bonding) are called physical hydrogels. These physically formed cross links present mainly strong or weaker crystalline regions in polymer chains.

Important biochemical properties of hydrogels that also involve hydrophilicity, charge and bioactivity are mainly derivated from hydrogel's chemical composition. These chemical precursors take part in non-covalent intramolecular interactions in polymer chain and also in intermolecular interactions that are presented between polymer chains in cross linked network and between this network and corresponding solvent. The side chains that are attached to the main polymer chain can also influence specific properties of hydrogel. The most significant premise for biochemical and medical purpose, that is very important when talking about health care, is that nowadays we are able to modify the chemical and physical properties of hydrogels (pH, temperature, charge) [6]. Due to the higher content of water holded in its structure they provide the biocompatible characteristics and this is also the reason why they are widely used in medicine and cosmetics.

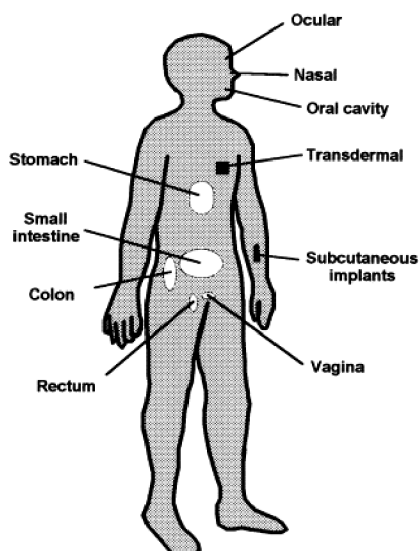

Figure 4. *The applications of hydrogels frequently used in health care [7]*

2.2.2 The gel formation

The process of gel formation is called gelation. Due to the linkage of macromolecular chains together the process starts by forming larger branched soluble polymers that are dependent on the structure and conformation of the initial material [8]. Polydisperse soluble polymer which is branched is then called 'sol'. If this process of binding continues the size of the new branched polymer increases with its decreasing solubility and the gel is formed. In other words, this infinite polymer undergoes the permeation with finite branched polymers ('sol') and the process of this remarkable change is known as gelation or 'sol-gel transition' and the new forming complex is then called 'sol-gel' system or only 'gel'. Within the process of gelation, the material which is supposed to be viscous, changes into the firm elastic substance. The binding mechanism observed during the gelation might be slightly different, the physical and chemical linkages are distinguished. Hydrogels that involve the chemical linking are characterized by the polymeric chains that are covalently linked together. On the other hand, physical hydrogels are held together by molecular entanglements and by molecular interactions such as ionic bonds, hydrogen bonds or van der Waals interactions [15].

2.2.3 The gel matrix – traditional ingredients

Further mentioned materials used as the compounds for a network formation have many applications and also take part in controlled release systems.

PHEMA or poly(2-hydroxyethyl methacrylate) is considered to be the most commonly used polymer in drug delivery applications [9]. This polymer is very stable and provides the hydrophilic aspects. The permeability of the PHEMA membranes are well – controlled by the degree of cross-linking which is applied. There was a study on the drug release behaviour of hydrocortisone as an active agent presented in the structure of PHEMA and it has shown that the polymer undergoes the non-Fickian release process [10].

Poly(vinyl alcohol) represents another hydrophilic polymer commonly used in biomedical applications. It carries a premise for biological drug delivery systems because of its nontoxicity and because it exhibits good the mucoadhesive properties [9]. The

applications of copolymers PHEMA (Hydron[®]) and PVA as delivery devices for polypeptide drugs were studied and based on the results of these investigations they were proposed as the useful materials for the release systems [9], [11].

Poly(ethylene glycol), also known as PEG, is spreadly used in biological drug delivery applications because of its protein resistance [9]. A study which explained the diffusional behaviour of cytochrome C and hemoglobin provided new information on the dependence between the cross-link density and protein diffusion coefficient and the starting molecular weight of the PEGs [9], [12].

The materials, recently studied with respect to their biomedical applications are polymers which are able to respond the pH changes. For instance, these are: polyacrylamide, poly(acrylic acid), poly(methacrylic acid), poly(diethylaminoethyl methacrylate) [9].

Another class of polymers is used in the preparation of the hydrogels which are supposed to be temperature-sensitive. A good representative of such a polymer is PNIPAAm (poly-*N*-isopropylacrylamide) [9].

Natural polymers, so called biopolymers, are also expected to be mentioned as well. Moreover, these are produced by living organisms and some of them are useful for biomedical and pharmaceutical applications. For example: fibrin, hyaluronic acid, dextran, methylcellulose, alginate, chitosan [14].

Table 2. *Hydrogel applications and the list of utilized polymers (modified from [8])*

Application	Polymers
Wound care	polyurethane, poly(ethyleneglycol), poly(propyleneglycol), poly(vinylpyrrolidone), agar, xanthan, methylcellulose, carboxymethylcellulose, alginate, hyaluronan and other hydrocolloids
Drug delivery, pharmaceutical	poly(vinylpyrrolidone), starch, poly(acrylic acid), carboxymethylcellulose, hydroxypropylmethylcellulose, polyvinylalcohol, acrylic acid, methacrylic acid, chitosan, α,β -glycerophosphate
Tissue engineering, implants	poly(vinylalcohol), poly(acrylic acid), hyaluronan, collagen
Others (agriculture, waste treatment, separation, etc.)	starch, xanthan, polyvinylalcohol, poly(vinylmethylether), poly(<i>N</i> -isopropylacrylamide)

Apart from the materials used during the gel formation, it is also necessary to sustain the new formed hydrogel 'pure'. When talking about cosmetic or pharmaceutical applications the preservatives are expected to be used as well. The list of chemicals that are utilized as preservatives in cosmetic products is pretty rich and ample. For instance, these are Ammonium benzoate, Benzoic acid, Calcium disalicylate, Chlorbutanol, Ethyl benzoate, Formaldehyde, Glutaral, Phenyl benzoate, Potassium benzoate, Benzyl alcohol [26] and also Paraben esters, Phenoxyethanol, organic acids and halogenated compounds [27]. Instead of the chemicals that have been already mentioned, there is a group of preservatives which are commonly used as the powder or liquid products which are added to the raw materials and there are some examples; Benzylalcohol, Honeysuckle blend, Caprylyl Glycol, EDTA, Potassium Sorbate [26].

2.2.4 Diffusion methods

To decide if a hydrogel is useful for the biomedical purposes it is necessary to determine the swelling behaviour and barrier and permeability properties of the gel material. In order to describe the process of hydrogel swelling, the percentage of swelling is observed as expressed by the swelling equation [5]:

$$\%S = \frac{W_s - W_d}{W_d} \cdot 100 \quad (1)$$

where $\%S$ represents the percentage swelling, W_s weight of swollen gel and W_d weight of dry gel.

Evaluation of the barrier properties of the gel is provided with the appropriate solution of Fick's laws that explain the diffusion processes which take place in the material. The diffusion properties of the system are quantitatively characterized by the diffusion coefficients of solutes that are usually obtained from the diffusion experiments that are commonly done in an appropriate double cell diffusion apparatus (horizontal or vertical).

It is possible to calculate the diffusion coefficient D in the hydrogel at any time of the experiment due to the following equations [5]:

$$D = \frac{1}{\beta \cdot t} \cdot \ln \frac{C_D(t) - C_R(t)}{C_D(0) - C_R(0)}, \quad (2)$$

where

$$\beta = \frac{A_H}{W_H} \cdot \left[\frac{1}{V_D} + \frac{1}{V_R} \right] \quad (3)$$

where $C_D(0)$ stands for initial concentration of drug in donor; $C_R(0)$ initial concentration of drug in receptor; $C_D(t)$ concentration of drug in donor at time t ; $C_R(t)$ concentration of drug in receptor at time t ; A_H effective cross-sectional area of diffusion in the hydrogel sample; W_H width of the hydrogel sample; V_D volume of drug solution in donor and V_R volume of receptor fluid.

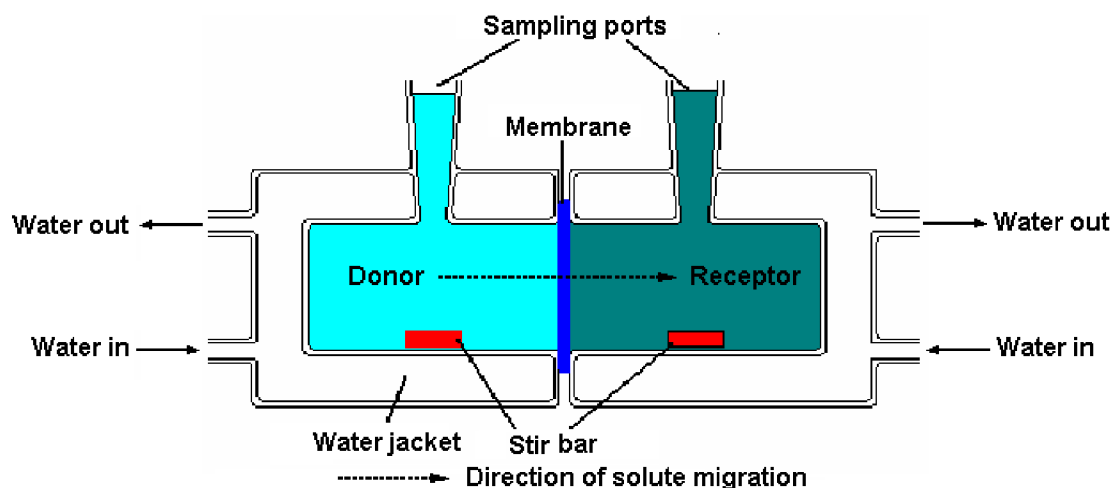

Figure 5. Schematic diagram of horizontal diffusion cell [5]

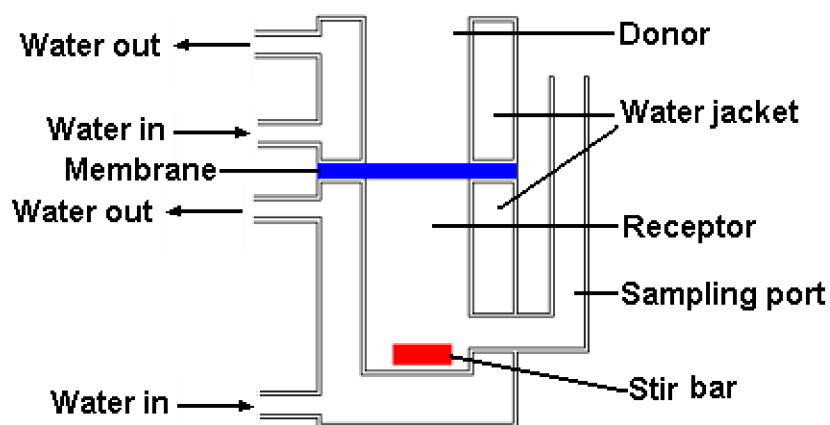

Figure 6. Schematic diagram of vertical diffusion cell [5]

The solute diffusion coefficient is affected by the specific interactions between the solute and the sample which passed through, by the solute in the course of its diffusion from the donor to the receptor chamber of the diffusion cells apparatus. The typical characteristics of hydrogels such as pore size and the polymer structure are not always the same and that is the reason why a new factor, tortuosity, is added. Diffusion mechanisms are also influenced by a nature of cross linkers. The diffusion goes easier when the molecular size of cross linker is small and that means that the cross linking reaction will run faster. Release of the solute from the hydrogel is connected with ionic and physical interaction of molecules and particles of the solute with the polymer chains of corresponding hydrogel. To summarize, the increase of cross linking density causes the decrease of the capacity to hold the water in the hydrogel and this is why the diffusion of the solute is reduced. The diffusion might be also influenced by the solubility of polymer, polymer molecular weight and the solute's molecular weight.

2.2.5 Drug controlled release systems

Biomedical applications of hydrogels also involve the drug delivery mechanisms which are needed when an active agent is expected to be released from the hydrogel. The

most conventional possibility how a drug might be released from a hydrogel is called diffusion. If the hydrogel carrying an appropriate drug comes into a contact with an aqueous solution, water penetrates into a system hydrogel-drug and dissolves the drug. This dissolved drug is then transported from the delivery system to the water medium by diffusion mechanisms. The diffusion of the active particle in hydrogel is dependent on the chemistry of hydrogel and this mechanism is also important when drug delivery systems are prepared. The drug delivery system is responsible for transferring the drug to the suitable surroundings where the active agent is aimed to be released. The empirical relationship which describes the drug transport and which is also called the power law can be applied to the most diffusion-controlled release systems [13]:

$$\frac{M_t}{M_\infty} = k \cdot t^n, \quad (4)$$

where M_t is amount of drug released at a given time t , M_∞ is amount of drug released at infinite time and k and n are the constants (characteristics of drug-polymer system).

The diffusional exponent, n , is dependent on the geometry of the device as well as the physical mechanism of release.

2.2.5.1 Diffusion-controlled delivery systems

Diffusion-controlled release mechanisms are classified into two categories – reservoir and matrix systems [13].

The core that stores a drug is encapsulated in a polymeric membrane of hydrogel which is able to diffuse the drug through the membrane. When this new formed system comes into a contact with water, water penetrates into the system, dissolves the drug and allows a concentration equivalent to the saturation solubility of the drug (C_s). Then the drug is transported through the membrane by diffusion mechanisms and the concentration of the system decreases below C_s . But the drug which is still presented in the core in solid state is also dissolved and is able to refund the concentration back to the C_s . Because of the presence of the drug in the core in solid state, the release mechanisms of the drug are permanent and are dependent on the presence of the solid drug in the core. Up to now, these systems follow the rules of zero order kinetics. However, if the drug which is presented in the core is spent, system follows the first order kinetics. This type of delivery mechanism is called reservoir delivery system and is usually used to deliver the active agent by oral, ocular and transdermal ways [5].

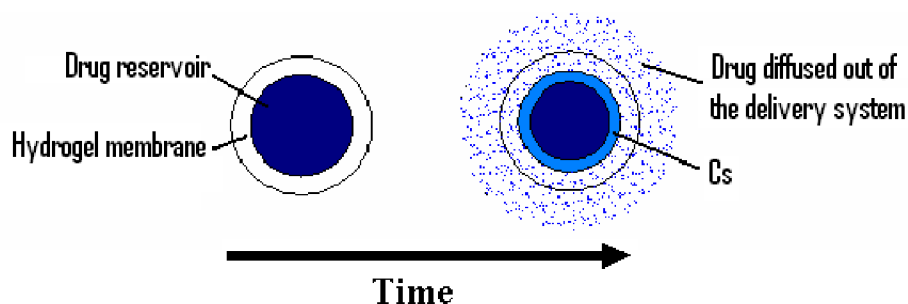

Figure 7. Drug delivery from reservoir system [5]

The second diffusion-controlled release system is the matrix system. The matrix system is built on a hydrogel matrix where the active agent is homogeneously dispersed in a solid state into the rate controlled medium. The delivery system and release controlled mechanisms of the drug are dependent on the structure and properties of the hydrogel matrix. When the hydrogel matrix comes into a contact with water, water penetrates into a system as well as it was in the previous case. Water starts to diffuse into the matrix in the surface and then passes to the central core of hydrogel and at the end the drug is released. The release of the drug is influenced by the diffusion of the water in the matrix and by diffusion of the dissolved drug from the matrix. To produce these delivery systems, it is necessary to choose inert polymers or bio-degradable polymers that are appropriate for this type of delivery mechanisms.

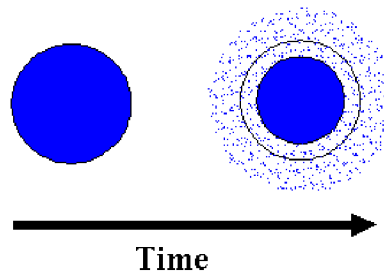

Figure 8. Drug delivery from matrix system [5]

2.2.5.2 Swelling-controlled delivery systems

Instead of the diffusion-controlled release mechanisms, there is another type of delivery system, swelling-controlled delivery system. The principle of this release system is that it occurs when the diffusion of the drug is faster than the hydrogel swelling [14]. To convert a hydrogel from a glassy state (where the captured molecules and particles are immobile) to a rubbery state (where molecules are able to diffuse), it is fundamental that the hydrogel undergoes swelling-driven phase transition. The release rate of the active agent from hydrogel depends on the swelling rate of polymer networks. The empirical relationship that describes the swelling-controlled drug release is derived from the empirical equation of the diffusion-controlled drug release but in the following equation are included also the drug diffusion and polymer relaxation [13]:

$$\frac{M_t}{M_\infty} = k_1 \cdot t^m + k_2 \cdot t^{2m} \quad (5)$$

where k_1 , k_2 , and m are constants.

An example of a swelling-controlled drug delivery mechanism is hydroxypropylmethylcellulose (HPMC). Before HPMC tablets were put into a contact with water they were in a glassy state. After water penetrates into a system, glassy state of HPMC undergoes the phase transition and the matrices are changed into a rubbery state. The rate of drug release is influenced by a rate of water transport and the thickness of the layer of the gel [13].

2.2.5.3 Chemically-controlled delivery systems

The chemically-controlled delivery system is the third class of the drug delivery system. This delivery system can be classified as purely kinetic-controlled release and reaction-diffusion-controlled release [13].

The kinetic-controlled release system is divided into two types: pendant chain system and surface-eroding system. The main characteristic of pendant chain system is that the drug is covalently bonded to the polymeric network of the hydrogel via cleavable spacers. The rate of the drug release then depends on the rate of the spacer-drug cleavage. It is common that the linkages used in these systems are hydrolytically degradable and follow the rules of the first order kinetics but these days there is an intention to form cleavable spacer linkages that are designed enzymatically and that is the reason which leads to the more complex release kinetics. The pendant chain release system is utilized when the increase of the drug activity is needed.

Another type of kinetic-controlled release system is surface-eroding system which is characterised by a relationship between the drug release and the surface erosion of polymer matrix. The main reaction that occurs in the system is hydrolysis so that means that the surface-eroding polymers are dependent on the hydrolytic-degrading polymers. The surface-eroding polymers are convenient vehicles for drug delivery applications because they provide an appropriate geometry for delivery device systems.

Reaction-diffusion-controlled release joins together two terms, reaction and diffusion. These systems represent active agent release as a combined reaction, bulk-degradation of polymer network and molecule diffusion, that is influenced by mechanical properties and swelling characteristics of hydrogel. Also known is affinity hydrogel release system where the developed hydrogel is able to decrease the rate of release of target protein therapeutics [13].

Instead of all these three active agent delivery systems, there are also composite hydrogel delivery systems presented. The composite hydrogel delivery systems are used in delivering multiple protein therapeutics that are significantly applied when talking about angiogenesis, bone remodeling or nerve regeneration. Two primary types of composite hydrogel delivery systems have been investigated, multi-layer and multi-phase systems.

2.2.5.4 Micro/nanoscaled delivery systems

Nowadays, there is a special topic that is often discussed, micro and nano world and this is why it is necessary to mention the micro/nanoscaled hydrogel delivery system too because nanoparticles have gained a prominent position in targeted active agent systems. Nanoparticles formed from hydrophilic hydrogels are used as the encapsulating particles that are able to carry biomacromolecules such as proteins or DNA. These nanoparticles contain appropriate active agent which might be delivered to the different parts of the human body, for instance via oral and nasal routes or it also can be injected.

3 CURRENT PATHWAYS

3.1.1 Medical applications of humic substances

In the past, peat was used as an additive in mud baths and was also applied in drinking cures, in order to cure intestinal, gastric, hepatic, gynecological, rheumatic, musculoskeletal and also skin diseases. But it must be mentioned that in the past there was not enough knowledge that would allow the exploration of the positive effects of both peat therapies and humic substances as well. We should admit that the science has improved a lot and nowadays the scientists are able to determine the biological effects of humic substances. These studies correspond to the antiviral activity of humic substances, to the specific behaviour of isolated enzymes, to the effects on a blood coagulation or estrogenic activity [16].

Foot and mouth disease and its healing process promoted by the humic substances was a precursor for the antiviral activity studies of humic substances. And again, peat was used in these studies to reveal how effective humic substances might be. It was explored that the humic substances support the combat against naked and enveloped DNA viruses such as Coxsackie A9 virus, influenza A virus or herpes simplex virus type 1 [16].

Humic substances show how important they are when they could also provide anti-inflammatory effects. There was a study on a rat paw edema model that explained that the sodium humate (twice as effective as acetylsalicylic acid or aminophenazone) inhibits the edema growing in comparison with unhealing processes [16]. As it is known humic substances have got different molecular weights and these can affect the inflammatory properties of humic substances. Pro-inflammatory properties are provided by the low molecular weight of humic substances which are responsible for the activation of blood cells – neutrophils. Pro-inflammatory properties also indicate the main building blocks of cartilage – chondrocytes. The study that focused on humic substances as electron donor-acceptor system showed that humic acids are able to produce and also to combine activated oxygen particles that are useful for injury treatments or cancer cells [16].

Besides the peat therapy is applied almost in every healing process, it is also used when talking about the blood coagulation. After a sterility operation, the complications might usually appear, for instance secondary adhesions or repeated occlusions of the ovarian duct. The adhesion-inhibiting effects provide peat extract baths that takes part in conversion of soluble fibrinogen into non-soluble fibrin via thrombin. Activated fibrin degrades due to the plasminogen activator (tissue released according to the humic acid's effect) which is responsible for antithrombotic defense [16].

Estrogenic activity of peat was explored in the bitumen fraction of peat. There were many unanswered questions about this topic. But it was found that the peat humic acids and the humic acid polymers contained in the peat proved an estrogenic activity of a peat. Because of mentioned facts humic substances may penetrate the skin and that is why they are used in cosmetics and in dermatology as well [16].

3.1.2 Skin and hydrogels

Nowadays, there is a group of scientists who are focusing on the skin treatment and the skin healing in a context of hydrogel application. The systems supporting the drug

delivery to the skin are requested because of their obvious benefits. The common use of the dermatologic active agents in hydrogels is for instance the disinfection of the skin itself or they are also used in healing processes during the skin diseases.

These benefits also include the fact that the hydrogels containing active agents can be delivered for a long duration at a constant rate and that means that the healing process is more effective. On the other hand, it is possible to interrupt the drug delivery if it is necessary by simply removing the drug delivery device. Another possible benefit of transdermal drug delivery is that the drug can bypass hepatic first-pass metabolism. Hydrogels are able to absorb high amounts of water and that is the reason why they provide better feelings for the skin tissues than the ordinary ointments.

3.1.3 Up-to-date research

3.1.3.1 Humic substances in medicine

There is a group of scientists who are attracted to the research of favorable effects of humic substances which do possess the unique physicochemical and also therapeutic properties. This part is considered to be a review of some of the nowadays applications of humic substances.

The study that explains the effects of combining a humic acid and arsenic trioxide was made as a proof of the growth inhibition properties of the above mentioned combined system in human cervical adenocarcinoma cells [17]. Because of the large number of patients suffering from the cervical cancer in the recent years there was an intention to improve the development of chemotherapeutics using arsenic trioxide combined with the humic acid. The presence of the humic acid showed that the viability of cervical cancer cells decreases with increasing amount of humic acid. It is said that the arsenic compounds act as apoptosis-inducing agents and that is one of the reasons why they have therapeutic effects on cervical cancer cells [18]. Two different types of cervical cancer cells were examined and underwent cell proliferation, programmed cell death and intracellular reactive oxygen species production. The study showed the growth inhibition of cancer cells to be enhanced due to the presence of metalloid (arsenic trioxide) and humic acid [17].

The experiment which had shown the antimutagenic and genotoxic effects of processed humic acids was tested on the yeast strain *Saccharomyces cerevisiae* D7 [18]. The humic acids which were examined were Humin-s 775, sodium humate, potassium humate, regenerated sodium humate, regenerated potassium humate and sodium humate which was obtained at the temperature of 250°C [18]. The yeast *Saccharomyces cerevisiae* D7 had been cultivated for 16-18 hours and after the centrifugation and other procedures the cell suspension was inoculated on the selective medium for the tryptophane conversion [18]. This study provides the information about the antimutagenic activity of humic acids which was tested on the yeast *Saccharomyces cerevisiae* D7 [18]. The highest antimutagenic effects showed potassium and sodium humates [18].

Humic acids and their antioxidant activity was the main purpose of the experiment [21]. These humic acids were extracted from the brown coal from Ukraine. The humic acid was expected to act as an inhibitor of radical-chain oxidation of hydrocarbons

(ethylbenzene and cumen) [21]. The graphic representation shows that the absorption rate of oxygen decreases with increasing humic acid concentration. Highly chemically active are free radicals which are found in the living organisms and that is the reason why compounds with antioxidant properties are needed. To evaluate the benefits of an inhibitor-humic acid, the authors used the hydrocarbons in a liquid phase. The experiment was done on the principles of gas-volumetric methods [21]. Due to the results of this study, humic acids are able to act as the effective inhibitors of radical-chain oxidation, it means that they provide the antioxidant activity and are recommended to be used in novel drug preparations and medicine [21].

There was a study that explains the dose-dependent effects of humic acid on blood coagulation [19]. The experiment included six humic acids of different types and also origins which were prepared in different ways. All these types had been extracted and purified using different precipitation cycles. As mentioned prepared humic acids underwent the thrombelastographic measurement methods and the reaction time was measured. The dependence of dose-dependent effects of humic acid on reaction time was examined in the range of concentration of humic acid of 7.8 to 1000 $\mu\text{g}/\text{mL}$ [19]. The measurements showed that the lower concentrated humic acids reduced the reaction time and provided a procoagulant effect but on the other hand humic acids prolonged the reaction time and provided an anticoagulant effect at high concentrations [19]. The two of the six examined humic acids showed both the anticoagulant and procoagulant effects and it means that so called bimodal behaviour of humic acids was also proved in this experiment [19].

The study which focused on silver nanoparticles was made using synthetic humic substances which were preferred to use over natural humic matter [20]. The authors explained this decision of using the synthetic humic substances as the standardization problem of naturally obtained humic substances which can easily change the properties of the product depending on the source of soils. These synthetic humic substances were used as the stabilizing and also reducing agents of silver nanoparticles which were then characterized by UV-VIS spectroscopy. The silver nanoparticles come into a contact with bacterial cell and attack its cell layers. Due to this fact, they possess the antibacterial characteristics. Also known are the antimicrobial and antifungal properties of humic substances. Due to the investigation of silver nanoparticles which were synthesized by using synthetic humic substances, these can be applied as the antimicrobial agents or can take part in medical devices constructions [20].

3.1.3.2 Modern trends in hydrogel – based delivery systems

There are new non-invasive techniques how to deliver the active agent presented in the hydrogel to the skin. There is a new strategy how to deliver the bioactive agent to the skin - by a microneedles system. The hydrogel forming microneedles systems have been designed as microneedles arrays that are made from hydrophilic polymers. These hydrogels systems consist of blank crosslinked needles projecting from a solid baseplate to which an adhesive drug reservoir is attached [22]. Then this needle array is applied to the skin and the diffusion of an active agent begins through the special swollen microprojections. The enormous benefit of this novel drug system delivery is that there are no polymeric residues in the tissue and this system provides controlled release of an active agent [22].

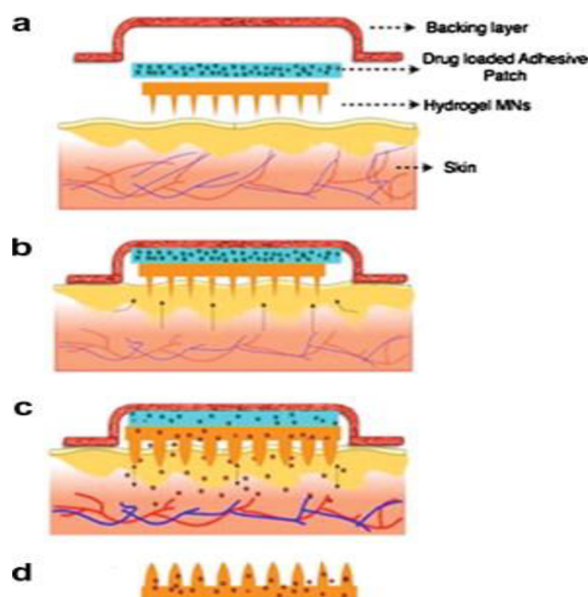

Figure 9. *Novel hydrogel-forming microneedles in controlled transdermal drug delivery* [22]

Another study was performed on the hydrogel blends which are predicted to improve the design of patches for transdermal delivery [23]. Two natural occurring polymers (pectin and gelatin) were used in the process of forming the hydrogel system in two-step gelation procedure (the thermal one and the ionic one). Thus formed hydrogel underwent the rheological measurements. In this case, the authors used as a model active agent testosterone because of its characteristics which are convenient for the transdermal delivery [23]. The rheological measurements showed that the formed patches are dependent on the hydrogel composition and set conditions of gel formation. Another target of these rheological measurements was to select the hydrogel patches with the appropriate visco-elastic characteristics which can be then applied to the skin. The in-vitro release tests had been done to optimize the method. The drug transdermal system had been studied on different apparatus; for instance, Franz's diffusion apparatus, rotating cylinder method and flow through diffusion cell [23]. The investigations led to the fact that the active agent release is controlled by the patch matrix and the transdermal hydrogel blends are needed to be examined by rheological measurements to determine the drug release and its sustainability [23].

The protein release from poly(ethylene glycol) hydrogels formed from poly(ethylene glycol) diacrylate, triethanolamine and 1-vinyl-2-pyrrolidone was examined in the study [24]. This hydrogel was formed via surface initiated photopolymerization. The formation of crosslinked network and its density through the hydrogel usually influences the control of diffusion of protein biomolecules. As an active agent the model protein GLP-1 was used (physiologically important protein). This biomolecule was incorporated into the hydrogel network with crosslink density gradients [24]. The results obtained from this study show that the release of the protein is stable and consistent with its size. The authors found that decreasing the protein size and increasing the molecular weight of PEGDA do all have promising impact on protein release [24]. The molecular weight of polymer also influences the distances among the crosslink juncture points. The formation of larger pores in

hydrogel structure makes the protein diffusion easier. By changing the monomer molecular weight and its concentration it is possible to influence the hydrogel characteristics and according to these manipulations also the protein diffusion [24].

Hydrogels have got special mechanical and physical properties and that is why they are spreadly used in medicine and pharmacy as well. Next study reveals the improved material properties resulting from the combination of a three-dimensional hybrid scaffold, 3D framework and hydrogel [25]. The hybrid scaffold was prepared by combining the alginate gel and 3D framework. The aim of forming of the above mentioned scaffold was to suggest tiny external dimensions which were proposed to be used as the spaces that will allow oxygen, nutrients, hormones and wastes to pass through the scaffold. The active agent used in this experiment was dopamine which was contained in specialized dopamine-secreting cells [25]. The hybrid scaffold was designed for having the non-natural occurring cells protected from the immune rejection of the host cell and for better mechanical properties of hydrogel which is eventually supposed to be used as a dopamine delivery system [25].

Another scientific approach was focused on the cancer-targeted controlled drug release via mesoporous silica composites [28]. The authors constructed layer-by-layer coating by synthesizing the chitosan gel mixed with CTAB and tetraethylorthosilicate. Doxorubicin was chosen as a water-soluble anticancer drug for the controlled release. It was explored that the folic acid must be conjugated to the outer surface of the gel to deliver the anticancer drug to the targeted tissue. Due to the formation of Schiff's bases which were formed during the network crosslinking reaction it was interesting to observe that the mesoporous silica particles possess the autofluorescent properties without any external fluorochromes. It was also investigated that the folate-modified mesoporous silica composites are predicted to be useful in treating cancer without endangering the normal health tissues [28].

4 EXPERIMENTAL PART

4.1 Chemicals and devices

- Lignohumate Amagro (potassium salt); Amagro Humic Substances s.r.o.
 - Sodium hydroxide micropearls G.R.; Lach-Ner, s.r.o.
 - Sodium chloride p.a.; Lach-Ner, s.r.o.
 - Polygel CA; 3V Sigma S.P.A.
 - Polygel CB; 3V Sigma S.P.A.
 - Synthalen M; 3V Sigma S.P.A.
 - Xanthan; Sigma-Aldrich
 - Distilled water
 - Inert silicone paste; Lukosan M14
-
- 25 mm jacketed Franz cell; SES GmbH-Analysesysteme
 - pH meter SevenEasy; Mettler Toledo
 - Rotating stirrer RW 16 basic; IKA[®]-WERKE
 - Membrane filters Pragapor 8 (diameter 50; pore size 0,23 µm); Pragochema spol.s.r.o.
 - Precision cells made of Quartz Suprasil (light path 10×4 mm); Hellma Analytics
 - Magnetic stirrer Variomag POLY; Thermo Scientific
 - Balance; ScalTec SPB 42
 - Fridge; Gorenje
 - Needles (d=0,8×120 mm); Santiago
 - Syringe (5 mL); Chirana T. Injecta
 - UV/VIS spectrophotometer; Hitachi U-3900H

4.2 Thickening agents

The thickeners which were used and which played one of the most important role of this experiment were: Polygel CA; Polygel CB; Synthalen M and Xanthan. All these issues are well-known synthetic polymers which are widely used in the cosmetic and pharmaceutical industry. Chemically, the first three substances are all defined as the carboxyvinyl polymers but they differ in viscous properties, Xanthan is the bacterial polysaccharide. These thickening agents are characterized as the fine white powders which are usually dispersed in water. However, it must be mentioned that it was necessary to regulate the pH with an appropriate base before the clear gel was formed.

4.3 Preparation of stock solutions of Lignohumate

The 1% and 5% stock solutions of Lignohumate were prepared by adding the Lignohumate powder into 1 L of water. These two Lignohumate solutions were used in the process of gel formation instead of water.

4.4 Preparation of neutralizing agent

It was necessary to prepare the neutralizing agent to regulate the pH and formation of gel samples. The inorganic base NaOH was used for these purposes. The 20% solution of NaOH was prepared in 50 mL of water. The aim of this agent was to regulate the pH of samples into the range of 6.50 to 8.50.

4.5 Preparation of receptor solution

The 0.1N NaCl prepared in 1 L of water was used as the receptor solution in Franz's cell's diffusion system.

4.6 Preparation of gel samples

4.6.1 Illustration – 2% Polygel CA with 1% solution of Lignohumate

1.022 g of powder Polygel CA was weighed and dissolved in 50 mL of 1% solution of Lignohumate. Thus prepared mixture was stirred until all particles were completely hydrated. At the end, the pH was regulated by adding 1.5 mL of 20% solution of NaOH up to 6.55 and the mixture was again stirred to avoid the lumps formation. After the clear hydrogel was formed, this substance was then used as the main building block of the diffusion experiments.

All of the gel samples were made in the same way as above mentioned. However, there was a difference in the amount of each powder, the volume of added neutralizing agent and the final pH of hydrogels. The complete insight is available on Table 3. and Table 4. .

Table 3. List of an amount of thickeners and the final pH of gel samples (5% LH)

	Thickener	m [g]	V_{NaOH} [mL]	pH
Dissolved in 50 mL of 5% solution of Lignohumate	2% Polygel CA	1.022	1.7	7.13
	2% Polygel CB	1.022	1.4	7.03
	2% Synthalen M	1.019	1.5	7.34
	5% Xanthan	2.630	-	8.40

Table 4. List of an amount of thickeners and the final pH of gel samples (1% LH)

	Thickener	m [g]	V_{NaOH} [mL]	pH
Dissolved in 50 mL of 1% solution of Lignohumate	2% Polygel CA	1.021	1.5	6.55
	2% Polygel CB	1.036	1.4	6.80
	2% Synthalen M	1.021	1.6	7.01
	5% Xanthan	2.629	-	7.72

4.7 Methods of characterization of humic substances release from the hydrogels

4.7.1 Diffusion experiments

The release of the Lignohumate as an active agent from hydrogel was performed in the specialized diffusion systems. This release was promoted by the vertical arrangement of diffusion cell, so called Franz's cell.

In this work, the 25 mL jacketed Franz's cell was used as the apparatus for diffusion experiments. The diffusion cell has got two shells, the outer one and the inside one. The outer shell might be used as the temperature controlled jacket, but it was not used in these experiments. The diffusion transport proceeded in the inside body of the cell.

At first, the flat ground joints were coated with the silicone paste in order to adhere the membrane. Then the membrane was placed on the ground joint and the top of the cell was pressed on the membrane. Into thus prepared apparatus, the 20 mL of the solution of NaCl were applied through the sampling port. The donor medium which was represented by the hydrogel sample was then placed on the membrane. To avoid the formation of sediments the stir bar was also added into the main body of Franz's cell and the receptor space had been constantly stirred.

At selected time intervals, the removal of sample from the receptor space which contained the specific amount of released active agent was done. These removals were performed during the whole release process and every time they were placed into the quartz cuvette where they had been analyzed by spectrophotometric measurements. After these tests the volume which was in the cuvette was removed and was again injected into the receptor space in order to sustain the constant volume in the diffusion apparatus.

All of the hydrogel samples (Tables 3. and 4.) were subjected to the release experiments in the vertical diffusion apparatus and all of them were examined three times.

4.7.2 UV–VIS spectroscopy

To find out the amount of released humic substance presented in the receptor space of the cell in different removal times, the UV – VIS spectrophotometric measurements were done. Due to the diffusion experiments which were always triplicated for every hydrogel sample, at the same time the UV – VIS measurements were made as well. Removed sample was placed into the quartz cuvette (10 mm light path) and the UV – VIS spectra were measured on the spectrophotometric device HITACHI U – 3900H. All the measurements were performed in the range of values of wavelengths between 250 – 850 nm. After the sample was examined, its volume was placed back into the cell. The absorption values were read out at the 465 nm and these data were then used for other evaluations.

4.7.2.1 Calibration curve

The calibration curve was made in order to determine the concentration of Lignohumate from the UV – VIS spectra of the removed samples. The powder of Lignohumate was dissolved in 0.1N NaCl so as the starting concentration of the solution was 2.0 g/L. Then the collection of the standard solutions with concentration of Lignohumate in the range of 0.4 – 2.0 g/L were prepared by controlled dilution of this starting solution. Obtained solutions were spectrophotometrically measured and the values of absorbance were also read out at the 465 nm and were plotted into a graph (Figure 36.).

5 DISCUSSION OF RESULTS

5.1 Characterization of humic substances release from the hydrogels

5.1.1 Diffusion experiments – the method optimization

To suggest the method which would clarify the way how would the active substance be released from the hydrogel matrix, it was decided to choose diffusion. Method which allows the active agent to penetrate through the membrane from donor space to the receptor space was optimized for this bachelor's thesis purposes.

All of the diffusion experiments were performed in specialized apparatus, so called Franz's cells which were optimized for these experiments. The vertical arrangement of these cells helped to perform the experiments more reliably in order to model the real situation. In other words, there was another target of these optimizations also, to approximate the release process as it was more or less performed on the skin. However, it must be mentioned that instead of the skin (which should act as the natural membrane), the membrane made of synthetic material with the specific pore size ($0.23\ \mu\text{m}$) was used.

The donor space of vertical cell was covered with the gel which contained the active substance – Lignohumate. It was necessary to cover the entire surface of the membrane with the hydrogel without any spare places to make the diffusion valid. Thus prepared donor space was then allowed to penetrate the membrane and to continuously release the active agent to the receptor space. The 0.1N saline solution was chosen as the solution for the receptor space (20 mL receptor volume) in Franz's cell in order to regulate the osmotic pressure. The increase of the ionic strength of the receptor solution ensured the active agent release to be continuous not sudden and also helped the hydrogel matrix not to absorb the liquid from the receptor space so intensively. Another reason why the saline solution was used as the receptor solution instead of water was the intention to simulate the physiological conditions within the experiment.

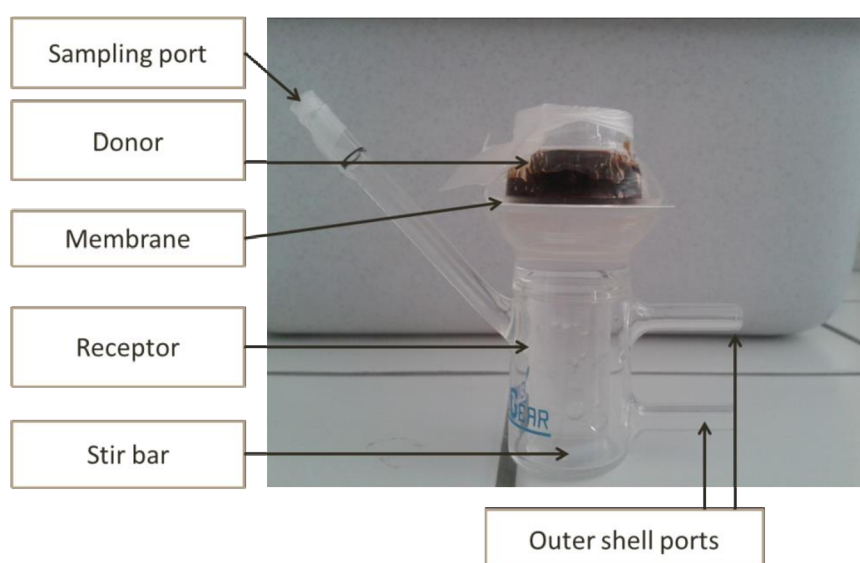

Figure 10. Apparatus – Franz's cell

Different types of gel matrix used for the diffusion experiments showed that the release of humic substance was distinct in each group of samples depending on the composition of hydrogel matrix. The release of an active agent was mainly affected by the concentration of Lignohumate solution in which the thickeners were dissolved. In general, it was explored that the gel samples prepared by dissolving the thickeners in 1% solution of Lignohumate were able to penetrate through the membrane filter significantly slower than if they were prepared in 5% Lignohumate solution. The amount of Lignohumate powder presented in the stock solutions influenced its release from the hydrogel form and also the experiment duration. The reason for this finding was obvious – higher concentration of the Lignohumate in the gel caused steeper concentration gradient across the membrane separating the donor and receptor chambre of diffusion apparatus. As far as the concentration gradient represents the actual driving power of the diffusion process, the rate of the Lignohumate penetration through the membrane would be correspondingly higher.

Table 5. *The experiment duration – 1% LH*

	Thickener	Experiment duration
Dissolved in 50 mL of 1% solution of Lignohumate	2% Polygel CA	7 days
	2% Polygel CB	6 days
	2% Synthalen M	7 days
	5% Xanthan	7 days

Table 6. *The experiment duration – 5% LH*

	Thickener	Experiment duration
Dissolved in 50 mL of 5% solution of Lignohumate	2% Polygel CA	30 hours
	2% Polygel CB	30 hours
	2% Synthalen M	30 hours
	5% Xanthan	25 hours

Another effect on the rate of the Lignohumate release could be attributed to the interactions between the Lignohumate and the thickener matrix inside the gel. The faster release of the humic substance as an active agent presented in the hydrogel matrix should probably mean that the interactions between the humic hydrogel formed from 5% Lignohumate solution and the thickening agents were significant and caused that the humic substance was held in the structure of hydrogel for a shorter period of time. Thus formed hydrogel would be better used in immediate utilization (faster release of an active agent) when talking about cosmetics or medical applications. On the other hand, gels formed from 1% Lignohumate solution showed slower release of the active molecule. The interactions of Lignohumate solution and thickeners were lower therefore the release of Lignohumate was slower. Hydrogels formed from 1% LH solution would find its applications in long-time healing processes.

The receptor solution with progressively releasing active substance had been analyzed during the whole diffusion process. The sample removal necessary for other analytical measurements was carried out using a long thin needle and syringe. At the beginning of the

experiments, short needles were used and these were able to remove the sample only from the sampling port. Instead of these short needles, we have decided to use long thin needles that would allow the removal to be done from the inside receptor space of the Franz's cell. The main purpose of the removals made by long thin needles was to reach the inside receptor solution, where the released substance was mostly stored. The concentration of the active agent was not spread homogenously in the space of sampling port even if the receptor solution was continuously stirred and that was the reason why there was a need to enter the interior space of the cell. The above mentioned removal was then placed into the quartz cuvette where it was analyzed.



Figure 11. *Long thin needle and short sampling needle with syringes*

After the removed sample was analyzed by the spectrophotometric measurements, this sample was given back to the receptor volume of the cell. According to this step we should be able to keep the receptor volume of the cell constant, however it was not possible as the receptor solution volume had gradually decreased. The hydrogel sample which was placed on the top of the cell had been absorbing the liquid from the receptor space to maintain itself hydrated. There was an intention to get through this obstacle by placing the gel sample in a desiccator filled up with water to keep the sample at the equilibrium hydration level. Note that in this case, the desiccator was used as an equipment for maintaining the 100% relative humidity not for drying. All of the gel samples had been placed in the desiccator for seven days but the situation was only slightly different and the significant change did not incurred. The fact that the gels absorbed a liquid from the receptor space could be probably caused by the low ionic strength of the saline solution used as the receptor solution and the consequent osmotic flow of the solvent (water) into the gel.

The injection of the analyzed removed sample back to the cell was performed in the way that the long thin needle was not placed into the inside body of the cell as there was in the case when the sample was removed but the needle was inserted in the top of the sampling port. The reason why the inverse injection was performed in the above mentioned way was the aim to avoid the bubble's formation. Once the bubbles were formed on the top of the receptor space just below the membrane filter, the diffusion did not run properly and the air bubbles obstructed the active humic substance to be released in full. The contact between donor and receptor space should be maintained without the formation of bubbles so the release process went correctly.

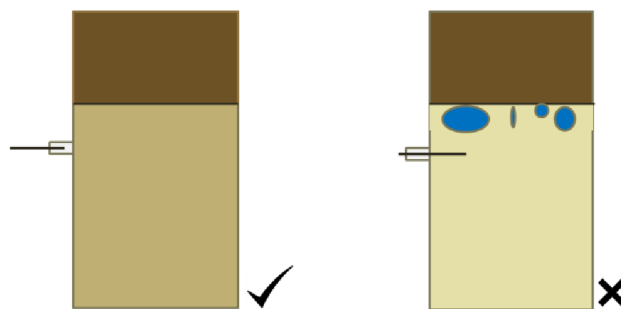

Figure 12. *Sketch of the inverse injection*

5.1.2 UV – VIS spectroscopy

To define a concentration of released active agent from each hydrogel matrix the UV – VIS spectroscopy was used as the appropriate method of determining the amount of the Lignohumate presented in the samples. The spectroscopic measurements were selected because of the fact that the humic substances do possess the ability to absorb the light from the ultraviolet and visible range. Due to the method of a calibration curve the absorption measurements were performed in order to determine the concentration of released active molecule in the receptor space of the cell in time. According to the information that the quartz cuvette has got transmission properties that allow the electromagnetic radiation in the UV – VIS range to pass through them, these natures were chosen for the measurements. There was necessary to use the absorption micro cell for the spectroscopic examinations because of the small amount of sample which was removed from the receptor space from the Franz's cell.

The change in absorption spectra with gradually increasing a content of the Lignohumate, released from the hydrogel matrix played an important role for understanding of the whole diffusion process. These changes provided us the information about how much was the active molecule released, how long the drug release ran and what changes brought the diffusion process within the donor and receptor space of the cell.

After all the measurements were done, the value of the absorbance at 465 nm was used for the calculation of the concentration of Lignohumate in the receptor solution.



Figure 13. *Absorption micro cell [30]*

5.1.2.1 Demonstrational Sample: 2% Polygel CA with 1% LH solution and with 5% LH solution

The gel sample which contained 1% Lignohumate solution passed through the membrane filter significantly slower so that meant that the diffusion process was longer and the absorption values at 465 nm were lower than in the other gel sample. Both of the gel samples were examined three times therefrom one of these were placed into a desiccator for seven days. The absorption spectra showed that the active Lignohumate substance had been constantly released. The first difference observed by comparing the data was the fact that the hydrogel sample formed from 1% Lignohumate solution reached lower absorption values at 465 nm than the gel formed from 5% LH. This status was caused by the force of the stock solutions in which the gel's matrix were prepared. The second difference was the fact that the gel sample formed from 5% Lignohumate solution which was placed in the desiccator showed the lower absorbance values than the gels which were not. The active molecule was incorporated into the hydrogel structure more strongly after the time spent in the desiccator and that might be a reason why the rate of its release decreased. On the other hand, the gels formed from 1% LH provided the same response when talking about the effect of using the desiccator only in the removals 5, 6 and 7 (shown at the Figure 14). This position could be a consequence of the interactions between the less concentrated humic hydrogel and the corresponding thickening agent. Moreover, both of the samples, whether with 1% LH or 5% LH, showed the upward trends.

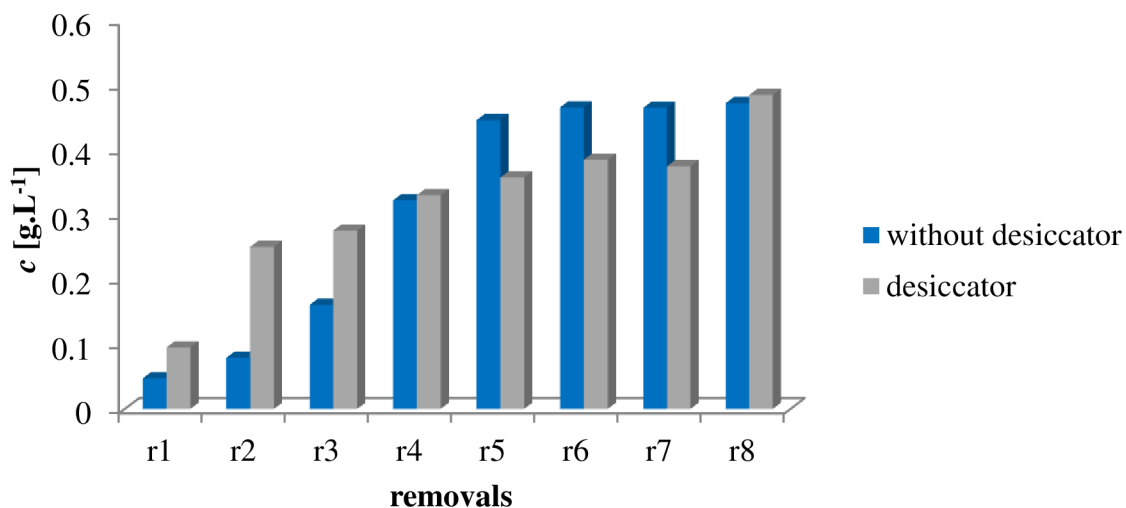

Figure 14. Active agent release trends – 2% Polygel CA and 1% LH

Table 7. Time periods of removals – 1% LH

2% Polygel CA and 1% LH solution	Time period [hrs]	
REMOVALS	1	1
	2	4
	3	21
	4	96
	5	97
	6	121
	7	125
	8	145

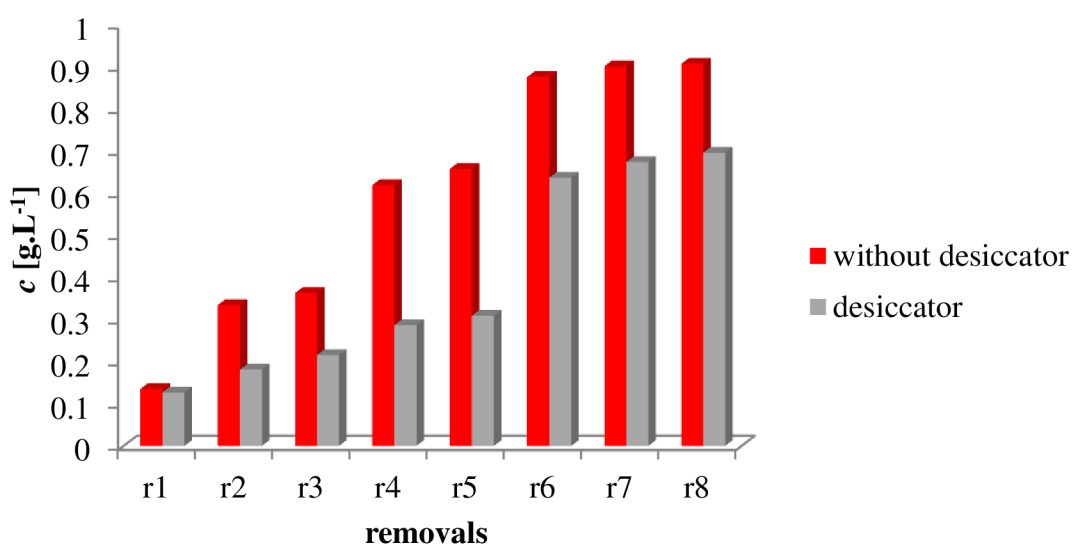

Figure 15. Active agent release trends – 2% Polygel CA and 5% LH

Table 8. Time periods of removals – 5% LH

2% Polygel CA and 5% LH solution	Time period [hrs]	
REMOVALS	1	1
	2	3
	3	5
	4	22
	5	24
	6	25
	7	26
	8	27

All of the removals were performed in a similar way for every hydrogel sample. The main difference which appeared during the removals was the volume of the saline solution

which was added into the receptor space in order to maintain the constant volume of the Franz's cell.

Due to the low linearity of the dependence of cumulative diffusion flux (total amount of the compound released from the donor to the receptor) on time, it was concluded that in general the gel samples did not undergo the steady – state diffusion. On the other hand, the dependence of the cumulative diffusion flux on the square root of time was linear and that was why the gel samples provided the non – stationary diffusion.

When talking about the non – stationary diffusion and its line's trends, it must be mentioned that near the end of the experiment, the initially linear dependence of the cumulative diffusion flux on the square root of time began to curve. This effect was probably caused by a cumulative mistake which resulted from the repeated supplementation of 0.1N sodium chloride into the receptor space of the cell.

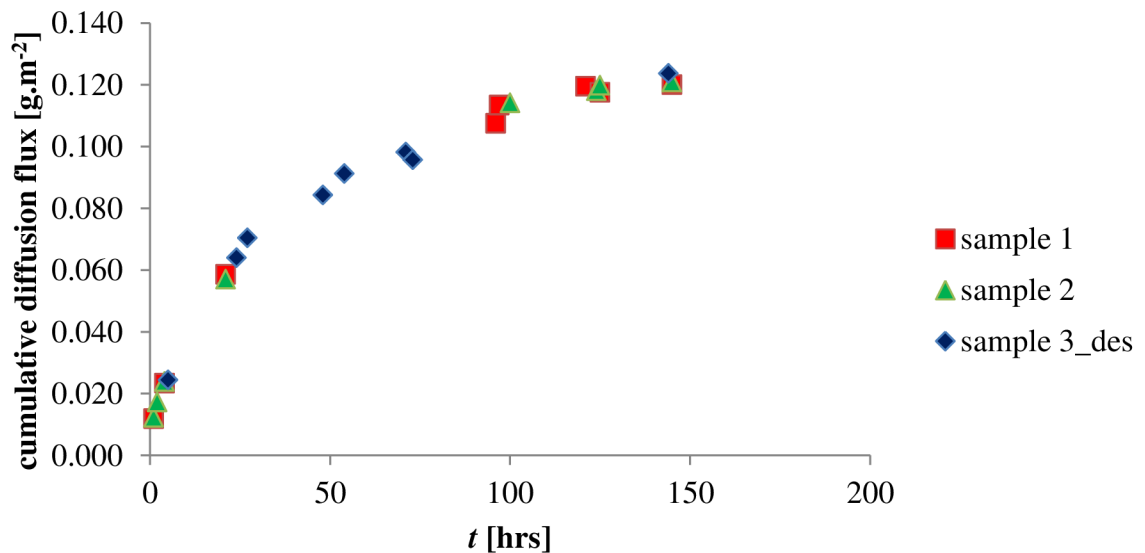

Figure 16. 2% Polygel CA with 1% LH; steady – state diffusion

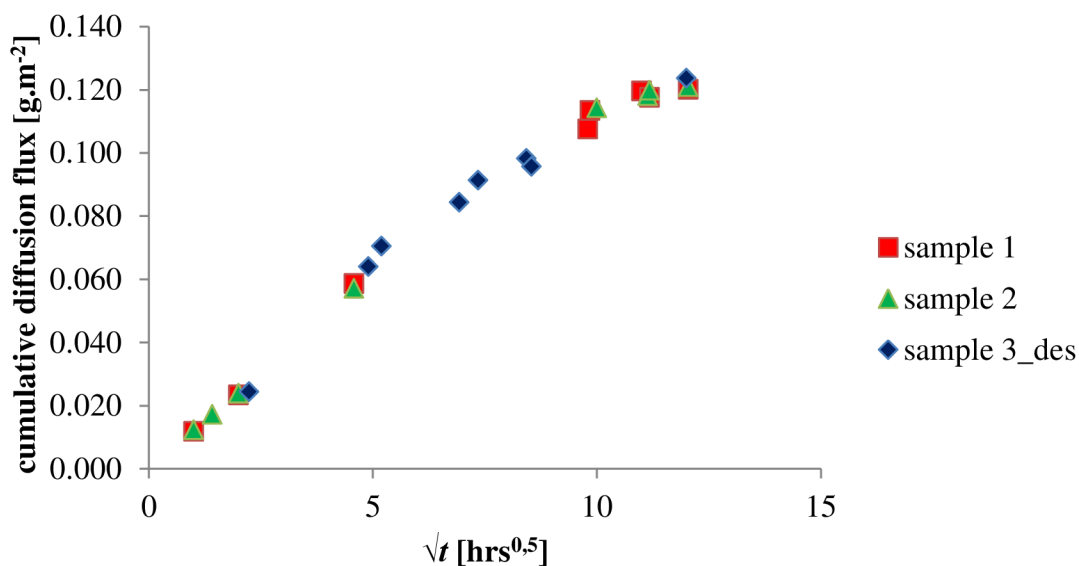

Figure 17. 2% Polygel CA with 1% LH; non – stationary diffusion

The linear parts of the non – stationary diffusion dependence were removed and the linear regressions of the data were performed. The slopes of these equations were used in order to compare the rate of the diffusion process for different hydrogels (differing in the thickening agents and the concentration of the Lignohumate).

In general, Polygel CA and Polygel CB behaved very similarly. On the other hand, it depended in what concentrated Lignohumate solution they were prepared. These two thickening agents showed that the releasing process of the active agent from 1% LH solution was performed less extensively than if they were dissolved in 5% LH. The samples which were placed in the desiccator with water showed stronger release of the active molecule when dissolved in 1% LH solution than in the 5% LH solution.

Synthalen M showed that the active molecule release was stronger from the 5% Lignohumate solution as well. But on the other hand, there was a difference between the samples prepared from 1% LH which were stored in the desiccator and the samples prepared from 5% LH solution which were also stored in desiccator. The hydrogel matrix made from 5% Lignohumate solution stored in the desiccator showed more intensive release.

The thickener Xanthan provided the similar release behaviour as the above mentioned thickening agents. The active molecule did not pass to the receptor space so intensively when this thickener was dissolved in 1% Lignohumate solution than there was in the case of dissolving in 5% Lignohumate solution. All the samples which were placed in the desiccator did not release the active molecule so quickly and it did not matter in which Lignohumate solution they were dissolved. The release trends were more or less the same.

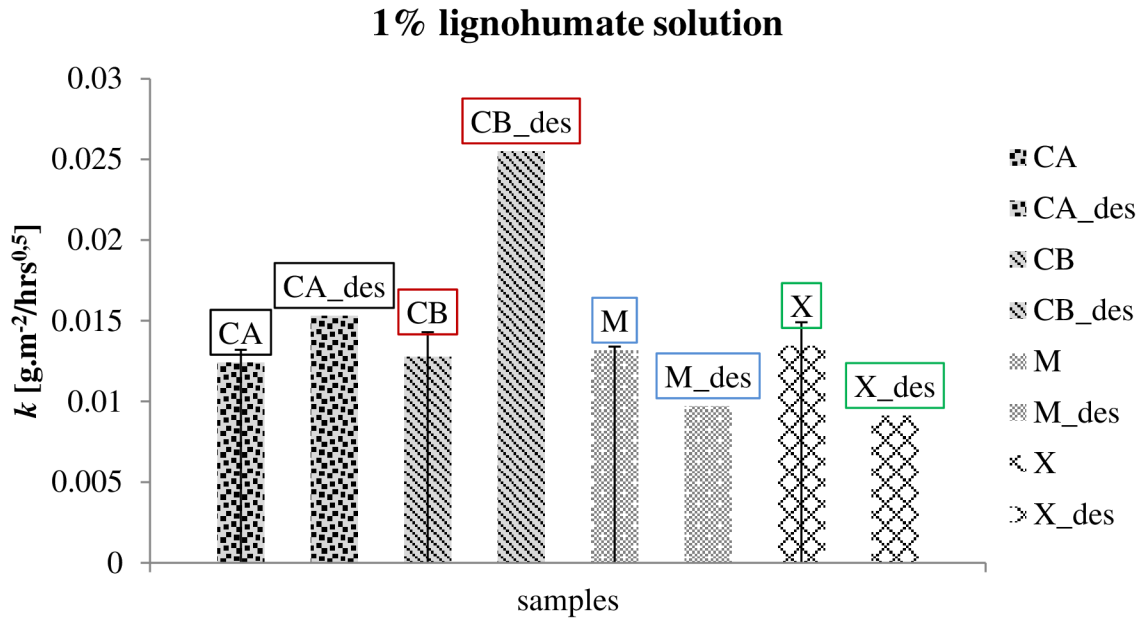

Figure 18. Dependence of the slope on samples prepared from 1% LH solution

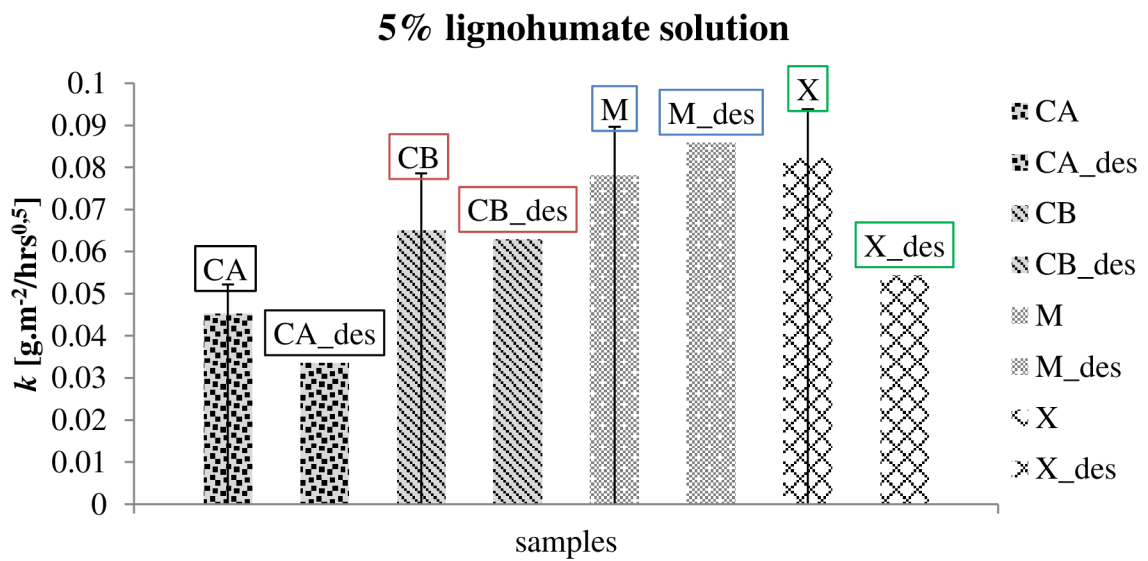

Figure 19. Dependence of the slope on samples prepared from 5% LH solution

6 CONCLUSION

This bachelor's thesis focuses on a design, testing and optimization of the method of experimental study on a release of the active molecule from a gel matrix. The main purpose of the thesis was to reveal the possibility of using the diffusion cell in vertical arrangement for all the experiments, to decide if there were any differences between using distinct thickening agents and Lignohumate solutions. Another aim was to characterize the intensity of released active molecule – humic substance from different types of hydrogel samples.

According to the pilot experiments, presented in this bachelor's thesis, the method of the Franz's cell appeared to be the method of the choice. The type of the diffusion cell was convenient for the drug release processes. As it was discussed in the experimental part, there were many critical points when talking about the optimization of the method, which were necessary to be solved in order to maintain the diffusion valid. For instance, injection of the saline solution into the receptor space of the cell; sample removals performed from the inside the chamber instead of from the sampling port; a small volume of the samples for spectrophotometric measurements and utilization of the micro cuvette; the inverse injection of the removal back to the chamber; etc.

Due to the basic evaluation of the experimental data, there was found that all of the gel samples provided the non – stationary diffusion release of the Lignohumate. The dependence of the cumulative diffusion flux on the square root of time was linear, at least in the initial steps of the experiment. The above discussed figures provided us with the information about the dependence of the slopes of straight lines on the types of samples. The experiments showed us that the thickening agents Polygel CA and Polygel CB behaved in a very similar way. Synthalen M and Xanthan possessed the same upwards trends as the Polygels, but these thickeners behaved in a little bit different way when dissolved in 1% Lignohumate and in 5% Lignohumate solution, especially when they were placed in the desiccator with water. The slopes of the lines involve somehow the actual value of the diffusion coefficient of the Lignohumate. In the follow-up experimental work, the exact determination of the diffusion coefficients should be performed by means of the release experiments, prolonged enough to achieve the equilibrium amount of the released Lignohumate. From these diffusion coefficients, the actual influence of the interactions between the Lignohumate and the gel matrix could be assessed.

Each of examined thickening agents behaved in a slightly different way when dissolved in 1% Lignohumate solution or in 5% Lignohumate solution. If we divide these mixtures into two categories, we are able to claim that the group of thickeners dissolved in 1% Lignohumate solution showed the slower and not so intensive release of the active agent than the group of thickeners dissolved in 5% Lignohumate solution. The less concentrated hydrogels could find its applications in continuous healing processes when the release of the drug is slower. On the other hand, the gels formed from 5% Lignohumate solution could be possible way in direct healing processes, where the release is required to be faster.

7 REFERENCES

- [1] WEBER, Jerzy. Definition of soil organic matter. Humintech [online]. 2009 [cit. 2013-06-10]. Available from: http://www.humintech.com/001/articles/article_definition_of_soil_organic_matter4.html
- [2] Humic substances-compounds of still unknown structure: applications in agriculture, industry, environment and biomedicine. *Journal of APPLIED BIOMEDICINE*. 2005, č. 3.
- [3] HUMÍNOVÉ KYSELINY. Pôvod a štruktúra. *Chemické listy*. 2008, č. 102.
- [4] SpringerLink [online]. 2000 [cit. 2014-03-13]. Available from: http://link.springer.com/article/10.1186%2F1467-4866-1-10/fulltext.html#Fig4_2
- [5] PAL, K., A. K. BANTHIA a D. K. MAJUMDAR. Polymeric Hydrogels: Characterization and Biomedical Applications –A mini review. *Designed Monomers and Polymers*. 2009, č. 12, s. 197-220. Available from: <http://dSPACE.nitrkl.ac.in:8080/dSPACE/bitstream/2080/1148/1/>
- [6] KIRSCHNER, Chelsea M. a ANSETH. Hydrogels in healthcare: From static to dynamic material microenvironments. *Acta Materialia*. 2013, č. 3, s. 931-944. Available from: <http://www.sciencedirect.com/science/article/pii/S1359645412007847>
- [7] PEPPAS, N. A., P. BURES, W. LEOBANDUNG a H. ICHIKAWA. Hydrogels in pharmaceutical formulations. *European Journal of Pharmaceutics and Biopharmaceutics*. 2000, č. 1, s. 27-46. Available from: <http://www.sciencedirect.com/science/article/pii/S0939641100000904>
- [8] Syed K. H. Gulrez, Saphwan Al-Assaf and Glyn O Phillips (2011). *Hydrogels: Methods of Preparation, Characterisation and Applications, Progress in Molecular and Environmental Bioengineering - From Analysis and Modeling to Technology Applications*, Prof. Angelo Carpi (Ed.), ISBN: 978-953-307-268-5, InTech, Available from: <http://www.intechopen.com/books/progress-in-molecular-and-environmental-bioengineeringfrom-analysis-and-modeling-to-technology-applications/hydrogels-methods-of-preparation-characterisationand-applications>
- [9] HYDROGELS. *Hydrogels*. 1999, č. 642.
- [10] J.M. Anderson et al., in J.D. Andrade, ed., *Hydrogels for Medical and Related Applications*, American Chemical Society, Washington, D.C, 1976, pp. 167-178.
- [11] R. Langer and J. Folkman, *Nature (London)* 263, 970-974 (1976).
- [12] P. Kofinas, V. Athanassiou, and E.W Merrill, *Biomaterials* 17, 1547-1550 (1996).
- [13] LIN, Chien-Chi a Andrew T. METTERS. Hydrogels in controlled release formulations: Network design and mathematical modeling ☆. *Advanced Drug Delivery Reviews*. 2006, 12-13, s. 1379-1408. Available from: <http://www.sciencedirect.com/science/article/pii/S0169409X06001694>
- [14] Natural and synthetic biomaterials for controlled drug delivery. *Archives for Pharmacal Research*. 2014, č. 1.
- [15] Spermidine-Cross-linked Hydrogels as Novel Potential Platforms for Pharmaceutical Applications. *Journal of Pharmaceutical Sciences*. 2013, č. 8.
- [16] KLOCKING, Renate a Bjorn HELBIG. Medical Aspects and Applications of Humic Substances. In *Biopolymers for Medical and Pharmaceutical Applications*. 2005, č. 1.

- [17] Humic acid enhances the cytotoxic effects of arsenic trioxide on human cervical cancer cells. *Environmental Toxicology and Pharmacology*. 2009, č. 29.
- [18] Antimutagenic and/or genotoxic effects of processed humic acids as tested upon *S. cerevisiae* D7. *Environmental Chem Letters*. 2010, č. 233.
- [19] *Functions of Natural Organic Matter in Changing Environment*. China: Springer, 2012. ISBN 978-7-308-10271-1.
- [20] Spectroscopy study of silver nanoparticles fabrication using synthetic humic substances and their antimicrobial activity. *Spectrochimica Acta Part A: Molecular and Biomolecular Spectroscopy*. 2013, č. 108.
- [21] Antioxidant Properties of Humic Acids from Brown Coal. *Solid Fuel Chemistry*. 2011, č. 6.
- [22] TUAN-MAHMOOD a MCCRUDDEN. Microneedles for intradermal and transdermal drug delivery. *European Journal of Pharmaceutical Sciences*. 2013, č. 1. Available from: <http://www.sciencedirect.com/science/article/pii/S0928098713001796>
- [23] Hydrogel blends with adjustable properties as patches for transdermal delivery. *International Journal of Pharmaceutics*. 2013, č. 454.
- [24] Characterization of protein release from poly(ethylene glycol) hydrogels with crosslink density gradients. *Journal of Biomedical Materials Research Part A*. 2014, č. 2.
- [25] Hybrid scaffold composed of hydrogel/3D-framework and its application as a dopamine delivery system. *Journal of Controlled Release*. 2013, č. 175.
- [26] *International Cosmetic ingredients dictionary* [online]. 1997, 2013 [cit. 2014-03-25]. Dostupné z: <http://www.makingcosmetics.com/INCI-63.html>
- [27] *The Preservation of Personal Care Products* [online]. 2009 [cit. 2014-03-25]. Dostupné z: <http://www.scss.org.sg/docs/SCSS%20Technical%20presentation%20K%20Roden.pdf>
- [28] Autofluorescent and pH-responsive mesoporous silica for cancer-targeted and controlled drug release. *Microporous and Mesoporous Materials*. 2014, č. 186.
- [29] Web of Science. Web of Science [online]. 2014 [cit. 2014-03-31]. Dostupné z: http://apps.webofknowledge.com/CitationReport.do?product=WOS&search_mode=CitationReport&SID=Y17E3MVINiR3kMz8dST&page=1&cr_pqid=3&viewType=summ ary&colName=WOS
- [30] HellmaAnalytics. Hellma Group Website [online]. 2014 [cit. 2014-04-03]. Dostupné z: [http://www.hellma-analytics.com/kuevetten/135/en/pg_id,40\\$pg_id,40\\$g_id,29\\$item_id,50\\$product_type,\\$app,\\$sg,29\\$sr,\\$lp,\\$vol,/absorption-cells.html#50](http://www.hellma-analytics.com/kuevetten/135/en/pg_id,40$pg_id,40$g_id,29$item_id,50$product_type,$app,$sg,29$sr,$lp,$vol,/absorption-cells.html#50)

8 LIST OF SYMBOLS

Symbol	Characterization	Units
m	mass	g
V_{NaOH}	volume of neutralizing agent	mL
t	time	hrs
\sqrt{t}	square root of time	hrs ^{0,5}
k	slope of the straight line	g.m ⁻² /hrs ^{0,5}
c	concentration	g.L ⁻¹

9 LIST OF ABBREVIATIONS

CA	Polygel CA
CA_des	Polygel CA stored in desiccator
CB	Polygel CB
CB_des	Polygel CB stored in desiccator
M	Synthalen M
M_des	Synthalen M stored in desiccator
X	Xanthan
X_des	Xanthan stored in desiccator
LH	lignohumate solution
UV – VIS	ultraviolet – visible spectroscopy
CTAB	cetyl trimethylammonium bromide
PEGDA	poly(ethylene glycol) diacrylate
PEG	poly(ethylene glycol)
DNA	deoxyribonucleic acid
HPMC	hydroxypropylmethylcellulose
PHEMA	poly(2-hydroxyethyl methacrylate)
EDTA	ethylenediaminetetraacetic acid
3D	three - dimensional

10 ATTACHMENTS

10.1 UV – VIS spectra

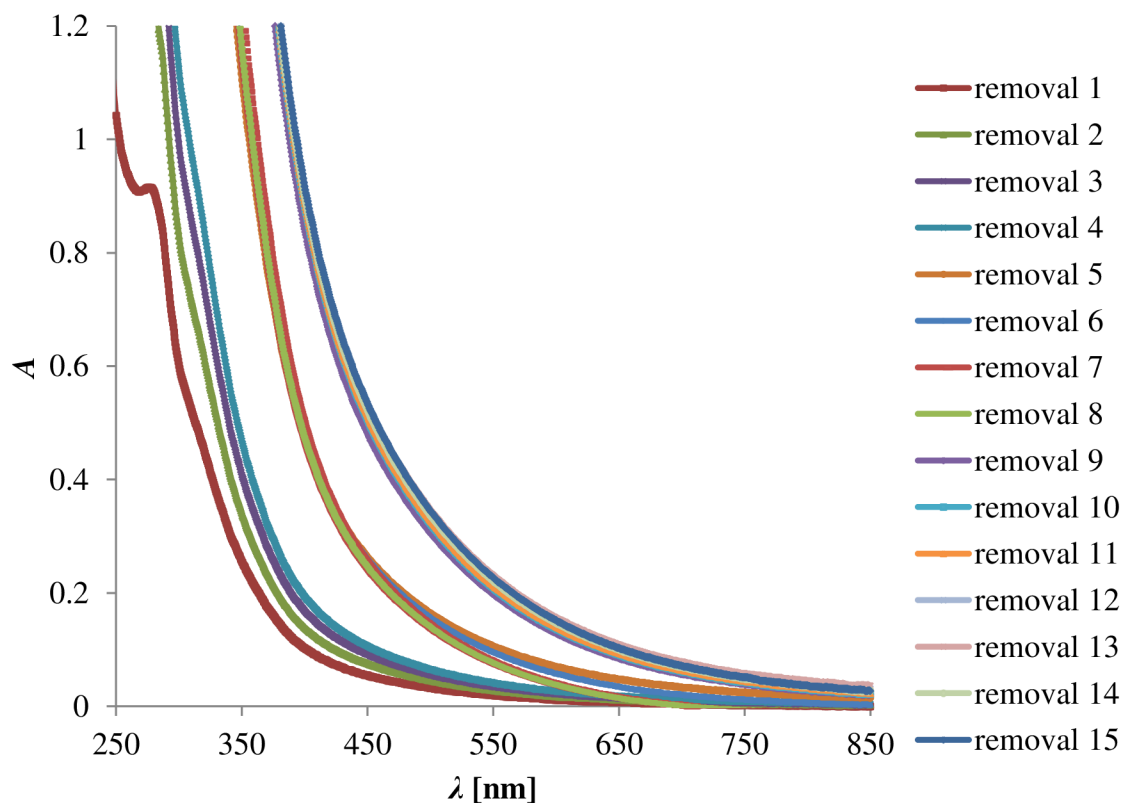

Figure 20. *Polygel CA with 1% LH; UV – VIS spectra*

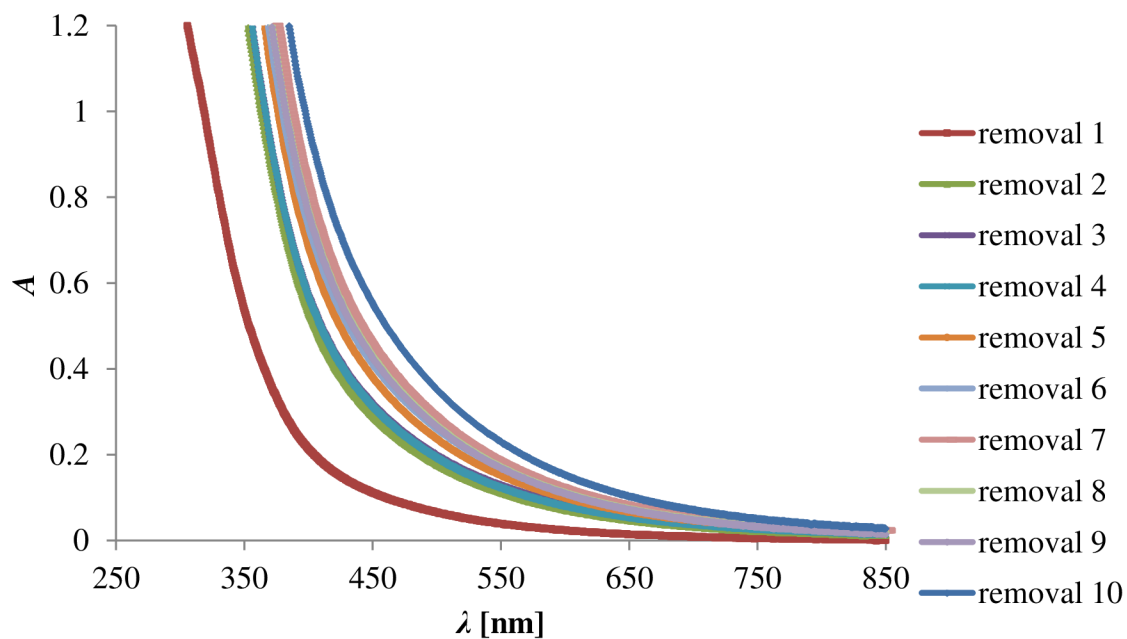

Figure 21. *Polygel CA with 1% LH stored in desiccator with water; UV – VIS spectra*

10.2 Different types of diffusion within different gel samples

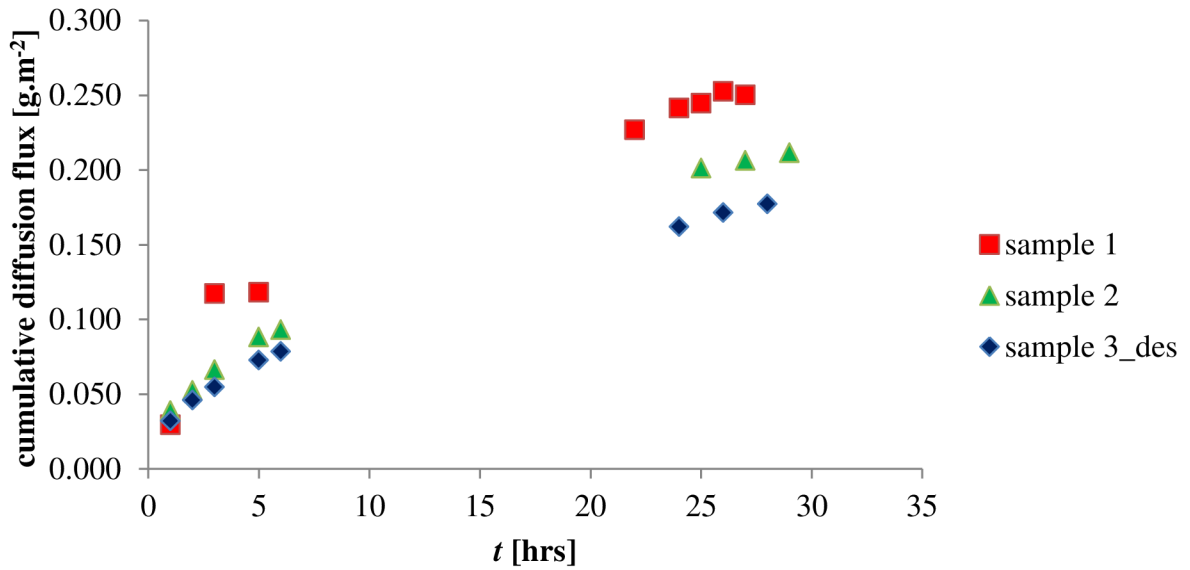

Figure 22. 2% Polygel CA with 5% LH; steady – state diffusion

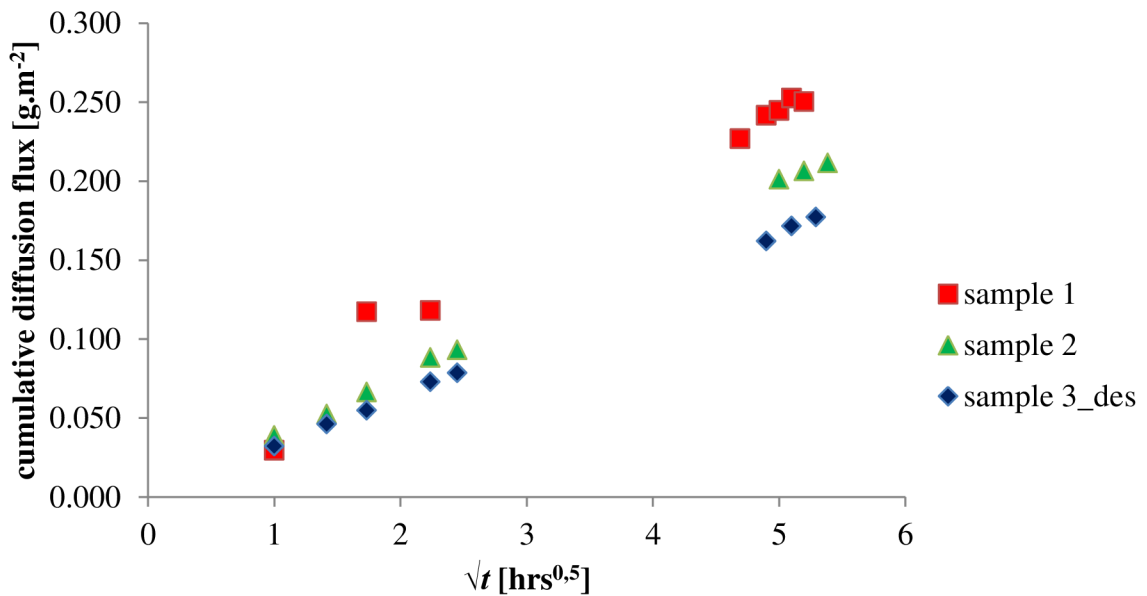

Figure 23. 2% Polygel CA with 5% LH; non – stationary diffusion

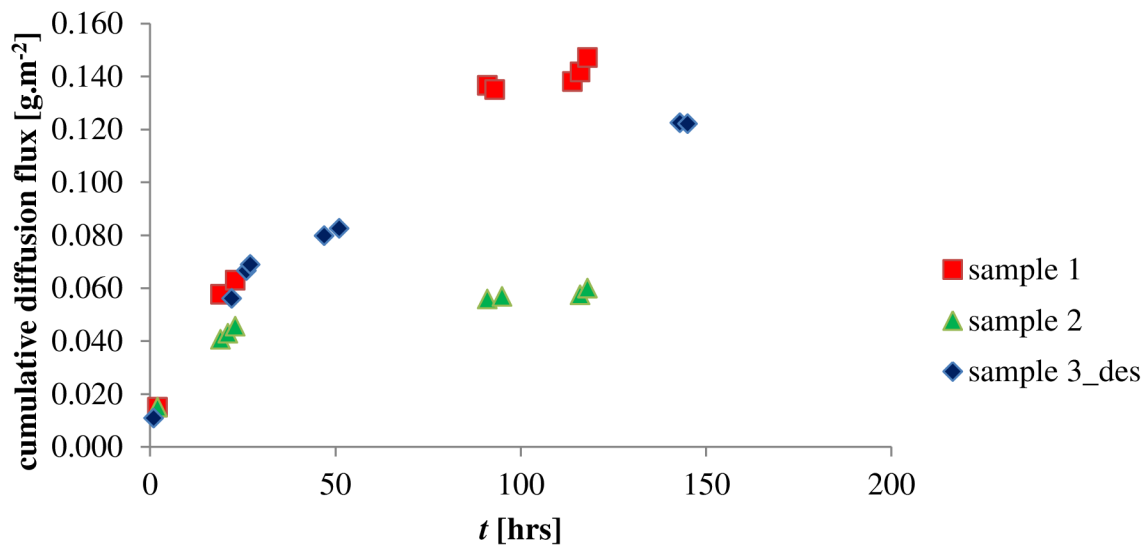

Figure 24. 2% Polygel CB with 1% LH; steady – state diffusion

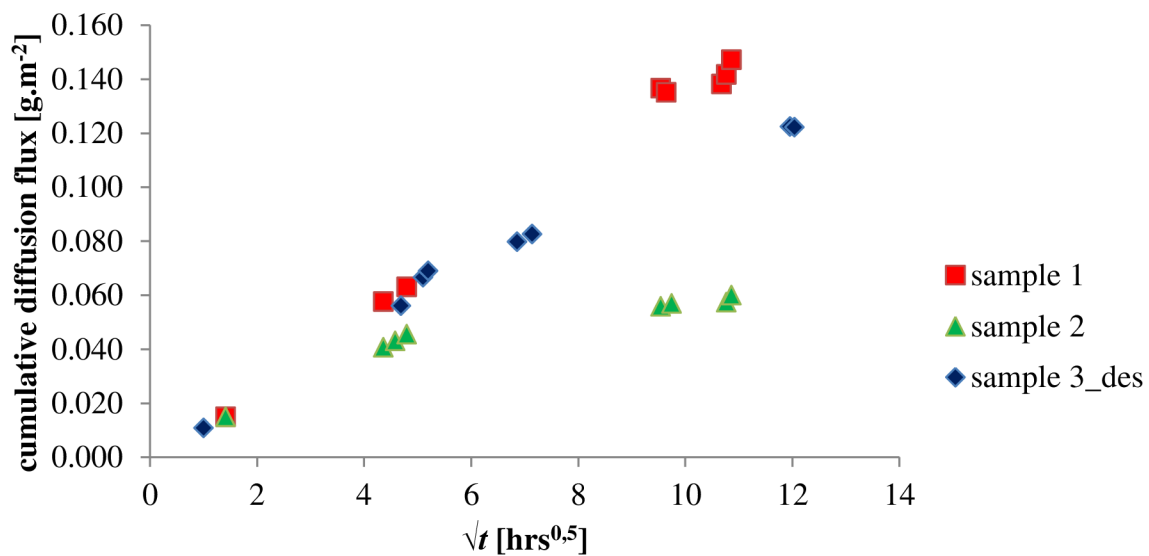

Figure 25. 2% Polygel CB with 1% LH; non – stationary diffusion

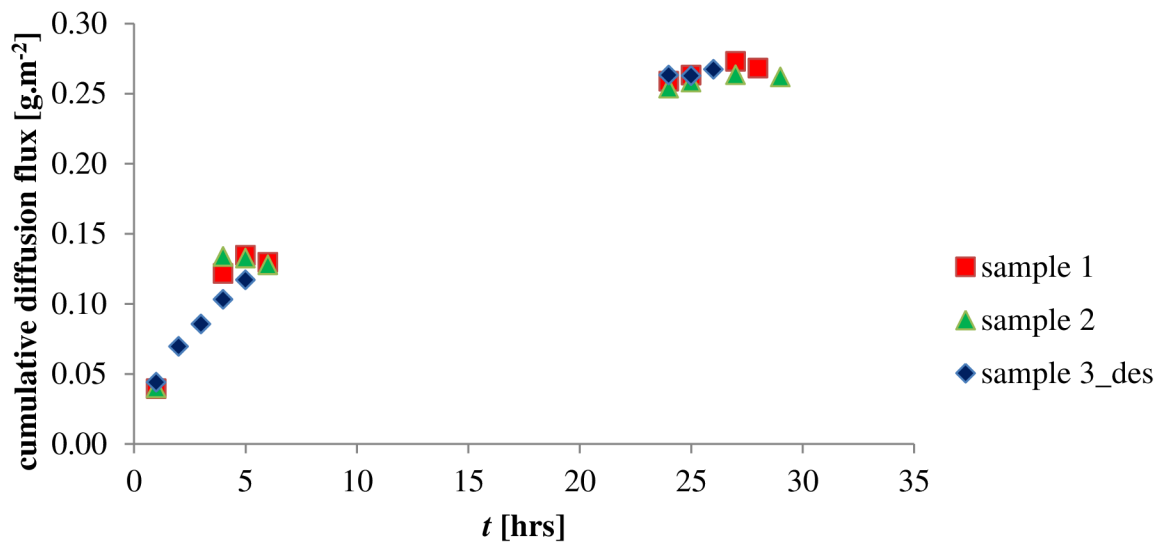

Figure 26. 2% Polygel CB with 5% LH; steady – state diffusion

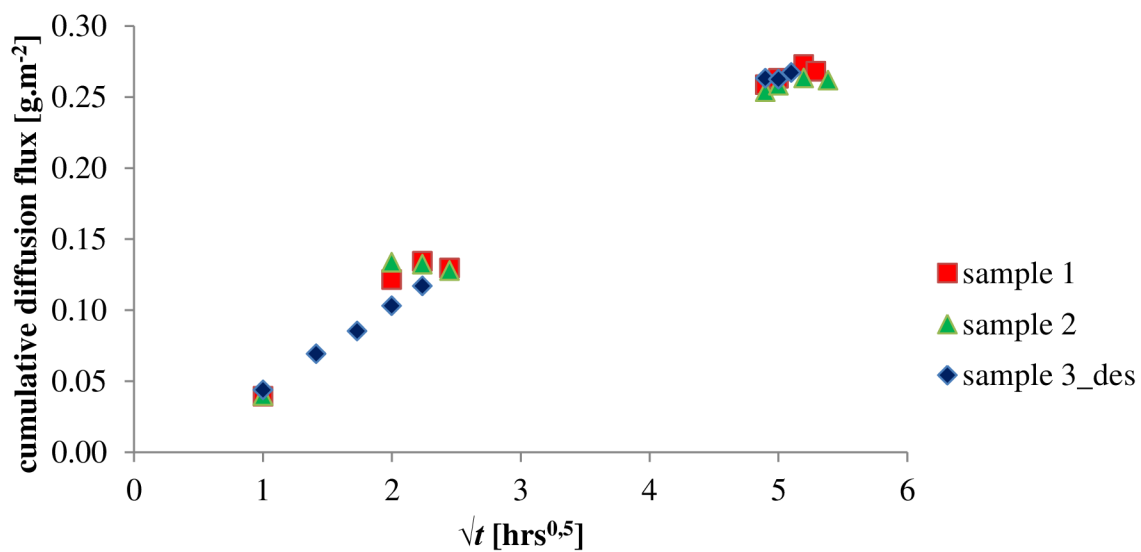

Figure 27. 2% Polygel CB with 5% LH; non – stationary diffusion

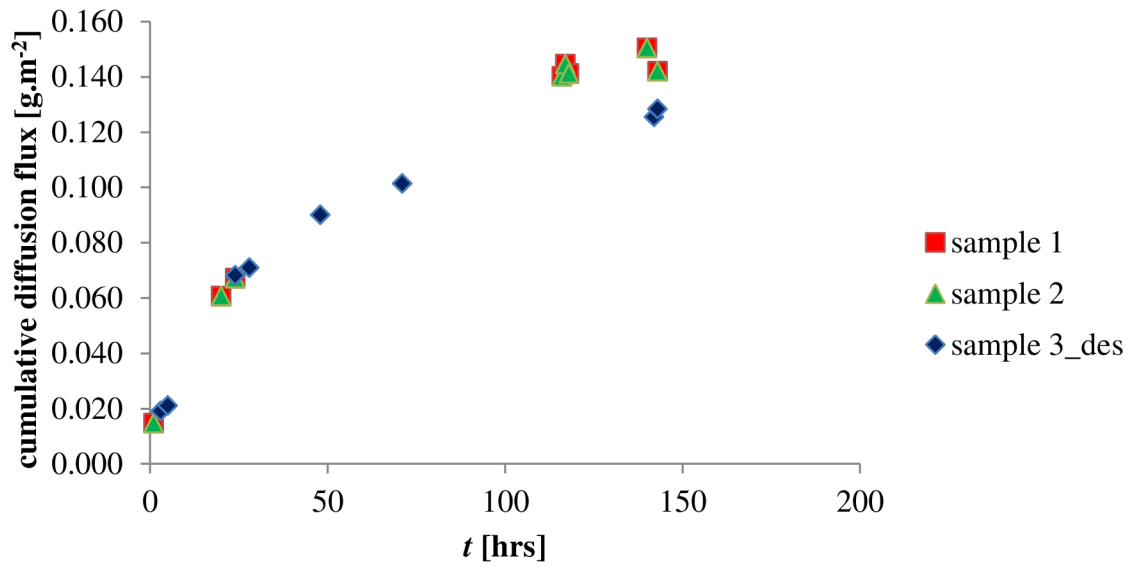

Figure 28. 2% Synthalen M with 1% LH; steady – state diffusion

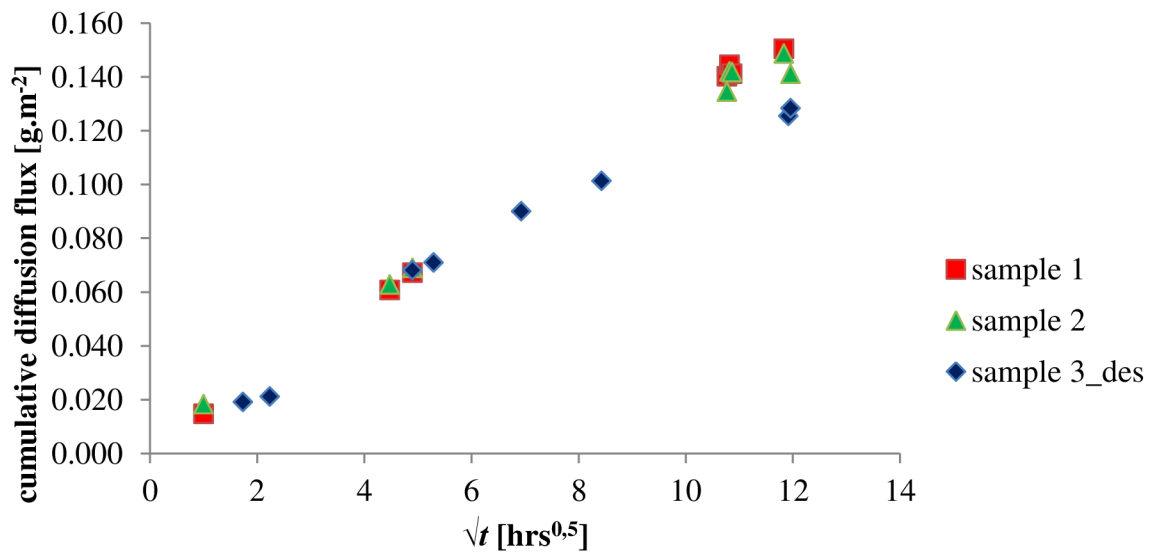

Figure 29. 2% Synthalen M with 1% LH; non – stationary diffusion

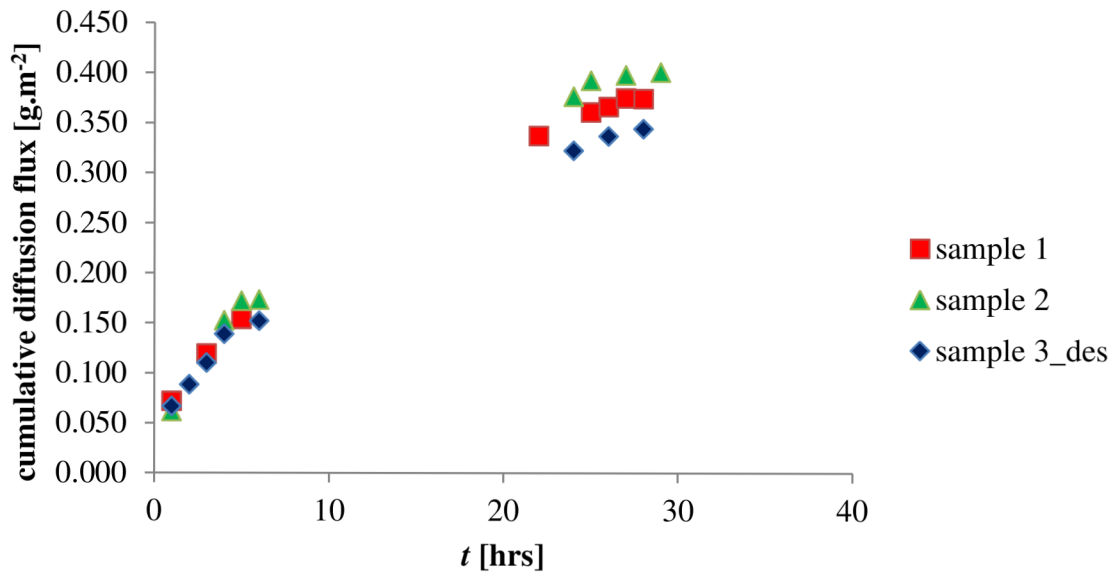

Figure 30. 2% Synthalen M with 5% LH; steady – state diffusion

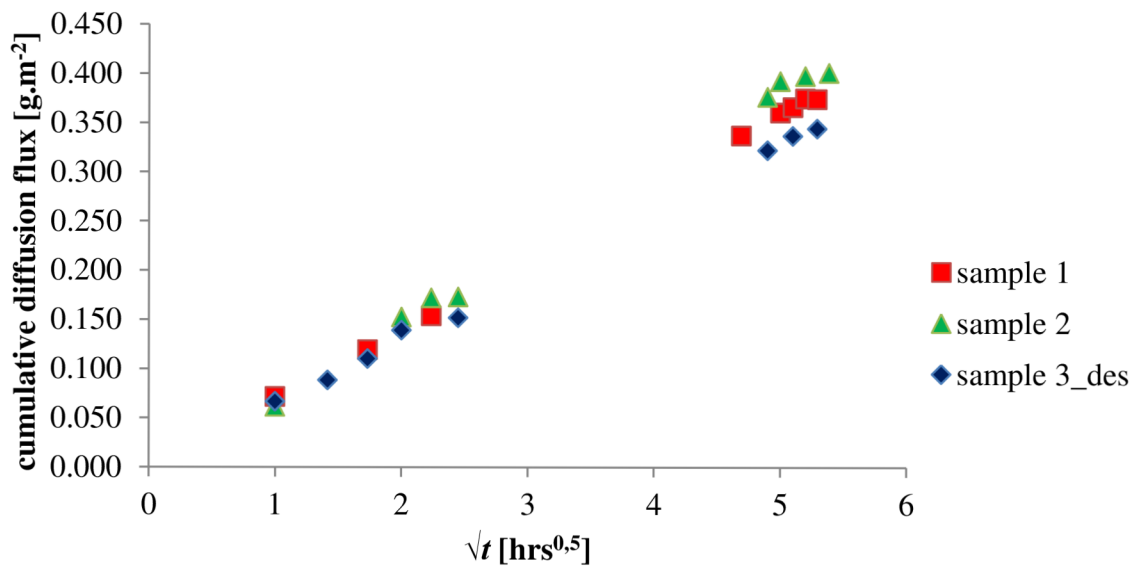

Figure 31. 2% Synthalen M with 5% LH; non – stationary diffusion

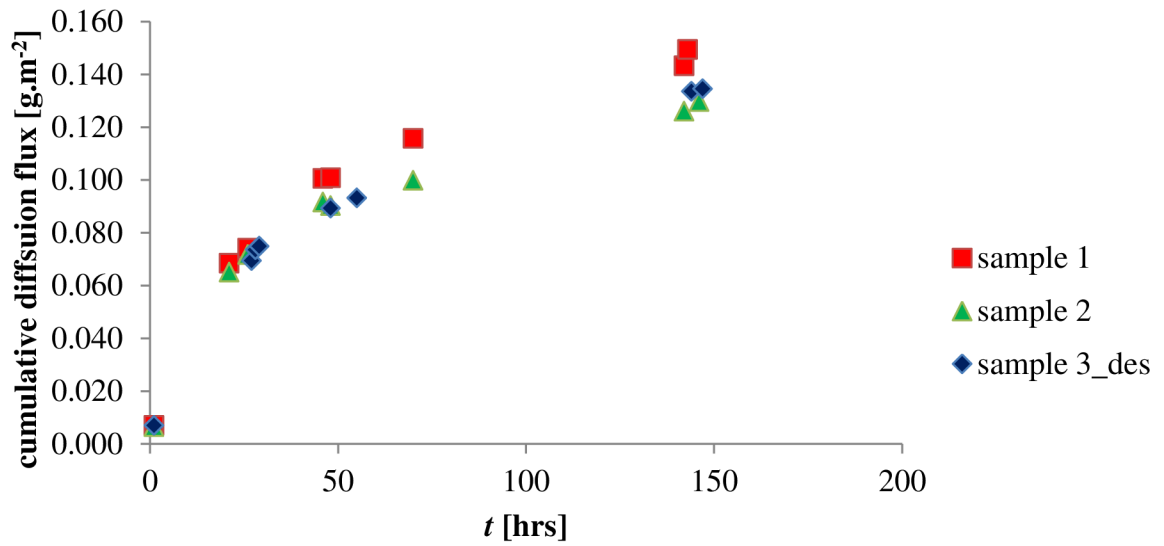

Figure 32. 5% Xanthan with 1% LH; steady – state diffusion

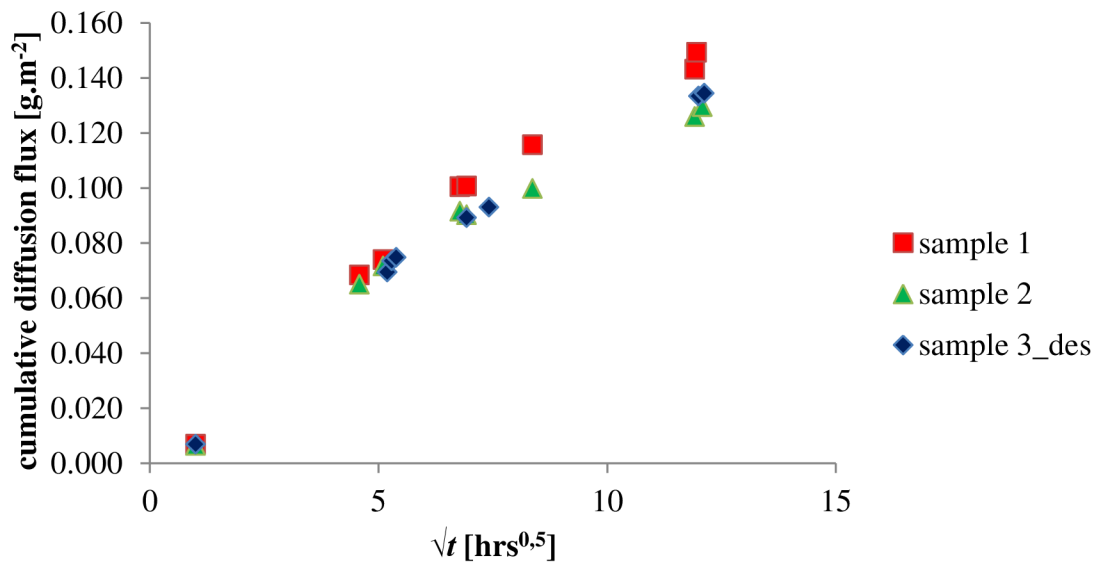

Figure 33. 5% Xanthan with 1% LH; non – stationary diffusion

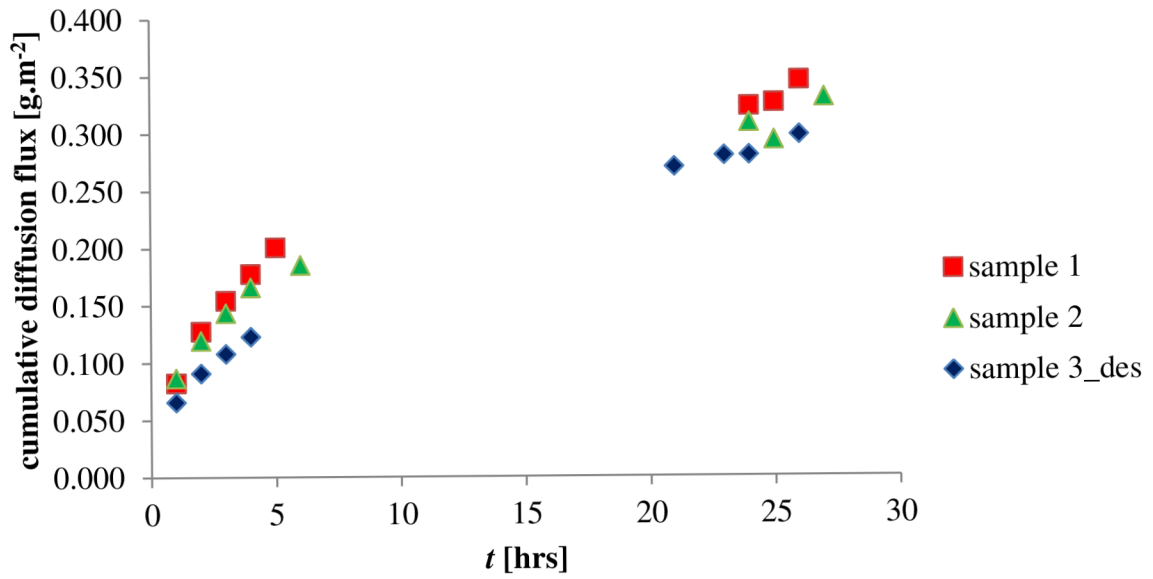

Figure 34. 5% Xanthan with 5% LH; steady – state diffusion

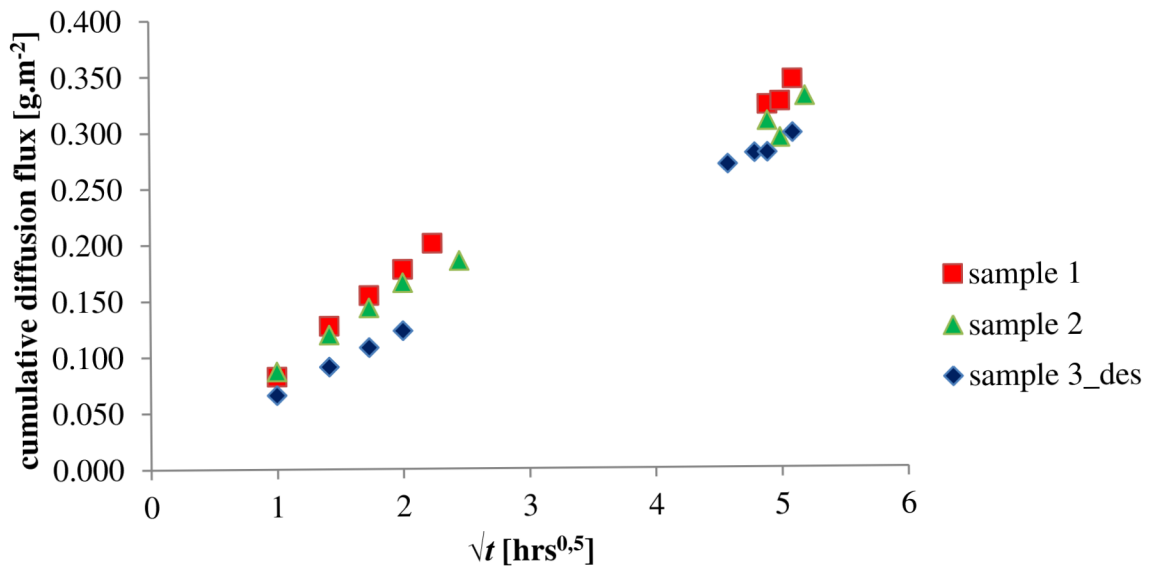

Figure 35. 5% Xanthan with 5% LH; non – stationary diffusion

10.3 Calibration curve

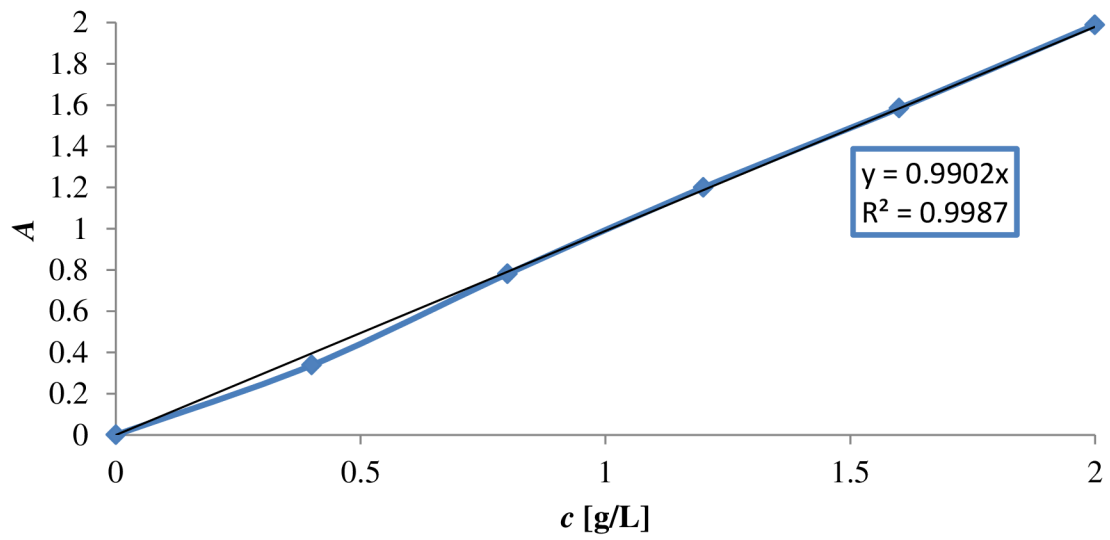

Figure 36. *The calibration curve*