



Dual-Material 3D Printing Using FLM Additive Technology

Master Thesis

Study programme:

N2301 Mechanical Engineering

Study branch:

Machines and Equipment Design

Author:

Gnaanesh Karunanithi Sumathi

Thesis Supervisors:

Ing. Petr Keller, Ph.D.

Department of Manufacturing Systems and Automation





Master Thesis Assignment Form

Dual-Material 3D Printing Using FLM Additive Technology

Name and surname: **Gnaanesh Karunanithi Sumathi**
Identification number: S19000363
Study programme: N2301 Mechanical Engineering
Study branch: Machines and Equipment Design
Assigning department: Department of Manufacturing Systems and Automation
Academic year: **2020/2021**

Rules for Elaboration:

This work aim is to test the two components printing on the 3D printer Rebel II, based on FLM technology. Printed parts will be from two different materials (e.g. ABS and TPU, ABS and Iglidur, etc.). Design the setting of printing parameters procedure, and if necessary, make changes in the printer design.

Recommended methods of elaboration:

1. Become familiar with the 3D printer Rebel II with dual head.
2. Make a research of existing works dealing with multicomponent printing using FLM, FDM, FFF technologies.
3. Design suitable parts for testing two-component 3D printing, such as a linear plain bearing, silent block, etc.
4. Prepare a design of experiments and on this basis perform practical tests of 3D printing to obtain the highest quality printing.
5. Evaluate your work.
6. Prepare a paper on this topic for publication in a technical journal or conference.

Scope of Graphic Work: according to need
Scope of Report: approx. 60 pages
Thesis Form: printed/electronic
Thesis Language: English



List of Specialised Literature:

- [1] GEBHARDT, A. *Understanding Additive Manufacturing: Rapid Prototyping – Rapid Tooling – Rapid Manufacturing*. Munich: Hanser, 2011. ISBN 978-3-446-42552-1.
- [2] WIMPENNY, D. I., L. J. KUMAR a P. M. PANDEY. *Advances in 3D Printing and Additive Manufacturing Technologies*. New York, NY, Springer Berlin Heidelberg, 2016. ISBN 978-981-10-0811-5.
- [3] SRIVATSAN, T. S. a T. S. SUDARSHAN. *Additive manufacturing: innovations, advances, and applications*. Boca Raton, Taylor and Francis, 2016. ISBN 9781498714785.
- [4] REPRAP. RepRap Forums [online]. 2016 [cit. 2020-09-15]. Available from: <http://forums.reprap.org/index.php>.
- [5] STRATASYS LTD. Professional 3D Printing. [online]. 2015 [cit. 2020-09-15]. Available from: <https://www.stratasys.com/fdm-technology>.

Thesis Supervisors: Ing. Petr Keller, Ph.D.
Department of Manufacturing Systems and Automation

Date of Thesis Assignment: November 19, 2020

Date of Thesis Submission: May 19, 2022

prof. Dr. Ing. Petr Lenfeld
Dean

L.S.

Ing. Petr Zelený, Ph.D.
Head of Department

Liberec March 5, 2020

Declaration

I hereby certify, I, myself, have written my master thesis as an original and primary work using the literature listed below and consulting it with my thesis supervisor and my thesis counsellor.

I acknowledge that my bachelor master thesis is fully governed by Act No. 121/2000 Coll., the Copyright Act, in particular Article 60 – School Work.

I acknowledge that the Technical University of Liberec does not infringe my copyrights by using my master thesis for internal purposes of the Technical University of Liberec.

I am aware of my obligation to inform the Technical University of Liberec on having used or granted license to use the results of my master thesis; in such a case the Technical University of Liberec may require reimbursement of the costs incurred for creating the result up to their actual amount.

At the same time, I honestly declare that the text of the printed version of my master thesis is identical with the text of the electronic version uploaded into the IS/STAG.

I acknowledge that the Technical University of Liberec will make my master thesis public in accordance with paragraph 47b of Act No. 111/1998 Coll., on Higher Education Institutions and on Amendment to Other Acts (the Higher Education Act), as amended.

I am aware of the consequences which may under the Higher Education Act result from a breach of this declaration.

May 27, 2021

Gnaanesh Karunanithi Sumathi

THEME: DUAL-MATERIAL 3D PRINTING USING FLM TECHNOLOGY

ACKNOWLEDGEMENT:

It is with immense gratitude; I acknowledge the support of my University for providing me this great opportunity to develop in deepest manner my engineering skills while accomplishing this diploma thesis and help them to further develop the importance in machine construction design.

I would like to thank, **Ing. Petr Keller, Ph.D.**, the supervisor of this diploma thesis, for his helpful approach, commitment to measure, professional advice, and critical reminders.

I would also like to thank our head of the department, **Ing. Petr Zeleny Ph.D.**, who has been a great support in every way to pursue our academics. Without his help, I might otherwise have never encountered successfully.

Furthermore, would like to thanks, **Ing. Petr Keller, Ph.D.** for providing guidance for the thesis writing.

I would also like to express my gratitude to The Department of Manufacturing Systems and Automation at the Technical university of Liberec for providing me the support I required, which gave me the opportunity to proceed freely with this work.

Finally, I am grateful to thank my whole family and friends for all the support, patience and encouragement throughout my studies.

This work was supported by the Student Grant Competition of the Technical University of Liberec under the project Optimization of manufacturing systems, 3D technologies and automation No. SGS-2019-5011.

Abstrakt:

Tato práce se zabývá 3D tiskem na tiskárně REBEL II pro tisk objektů ze dvou druhů materiálů (např. tvrdý a elastický materiál) v rámci jednoho tisku. Právě kombinace soutu tiskem tvrdého a elastického materiálu je nový způsob 3D tisku. Hlavním cílem je zlepšit kvalitu tisku a najít způsob, jak omezit ulpívání zbytků vláken na tištěném objektu. Nabízí se tak velké možnosti při vytváření plně funkčních dílů vytvořených z více materiálů vytištěných najednou. Pro zvýšení kvality tisku byla tiskárna vybavena gumovou stěrkou a kartáčkem pro čištění trysek.

Klíčová slova

3D tiskárna, technologie FLM, Rebel II, kvalitní, měkké a tvrdé materiály

Abstract:

This thesis works depends on the REBEL II 3D printer to print objects with different kind of materials (for example soft and hard materials) in a single run. It is expected that the combination of printing soft and hard material will be a new kind of 3D print. Main aim is to improve the quality of print and find a way to reduce the filament leftover get struck on the printed part. The different type of soft filament and hard plastic filament used to create fully functional, multi material objects in a single printing run with greater variety. In addition, silicon rubber and brush holder were developed for the nozzles cleaning, by using this it's possible to improve the quality of print.

Keywords:

3D printer, FLM technology, Rebel II, Quality, Hard and soft materials.

LIST OF CONTENTS

LIST OF CONTENTS	1
LIST OF FIGURE.....	4
LIST OF TABLE	6
LIST OF SYMBOL AND ABBREVAITION:.....	7
1. INTRODUCTION:	8
2. AIM OF THE THESIS:	9
3. ADDITIVE MANUFACTURING:	9
3.1. The Generic AM process:	10
3.2. Benefit of Additive Manufacturing:.....	12
3.3. Classification of Additive Manufacturing technology:.....	12
3.3.1. Powder Bed Fusion:	13
3.3.2. Directed Energy Deposition:.....	13
3.3.3. Material Extrusion:	14
3.3.4. Vat Photo Polymerization:	14
3.3.5. Binder Jetting:	14
3.3.6. Material Jetting:	14
3.3.7. Sheet Lamination:	14
3.4. Fused Deposition Modelling-(FDM)	15
4. PARTS OF FDM 3D PRINTER.....	17
4.1. Material Extrusion:	17
4.2. Nozzle:	18
4.2.1. Direct drive or direct extrusion:.....	19
4.2.2. Bowden:	20
4.3. Structure:.....	20



4.3.1. Cartesians printer:	21
4.4. Electronics:	21
4.4.1. Microcontroller:	22
4.4.2. Arduinio:	22
4.5. Structure	23
4.5.1. Cartesian printer:.....	24
5. COMPARING MM 3D PRINTER AND REBEL II:	25
5.1. PRUSA MNU 2.0:	25
5.1.1. Prusa MNU 2.0 concept:.....	25
5.1.2. Pros and Cons- Printers:.....	26
6. PRACTICAL WORK:	27
6.1. Rebel II- Printer – Dual Extruder:	27
6.2. Rebel II Dual Printer- Advantage:	28
6.3. Benefits of a REBEL II -dual extruder 3D printer:.....	29
6.3.1. Better for supports:	29
6.3.2. Multiple colors:	29
6.3.3. Multiple parts simultaneously:.....	29
6.4. 3D Model - Linear Bearing:.....	29
6.4.1. Outer Body Material- PLA:	30
6.4.2. Inner Body Material- Iglidur:.....	31
6.4.2.3. 3D printer filament: Iglidur® 150-PF:	31
6.5. 3D Model- Hard and Flexible material:.....	34
6.5.1. TPE 88 RubberJet:	34
7. REPETIER-HOST DOCUMENTATION:	36
7.1. Printer Configuration:	36

7.2. Units Settings:.....	39
8. CALIBRATION TEST:.....	40
8.1. Test 1:.....	40
8.2. Test 2:.....	41
8.3. Test 3:.....	42
9. PRINTING PROCEDURE - Linear Bearing:.....	43
9.1. Load the object:.....	43
9.2. Object placement:	44
9.3. Slicer:	45
10. PRINTER PRODUCTION- Hard and Flexible Material:	48
10.1. PursaSlicer:	48
10.2. Object Placement:	48
10.3. Slicer:	49
11. RESULT- Linear Bearing:.....	50
11.1. Linear Bearing- Trail 1:	50
11.2. Rebel II – Brush Support for Nozzle Cleaning:.....	52
11.3. Linear Bearing- Trial 2:	55
11.4. Ooze Shield:.....	55
11.4.1. Advantages.....	55
11.4.2. Disadvantages	55
11.5. Linear Bearing- Trail 3:	56
12. RESULT- Hard and Flexible Material:.....	57
12.1. Hard and Flexible Material- Trail 1:.....	58
12.2. Hard and Flexible Material- Trail 2:.....	58
13. DIMENSION COMPARSION OF 3D PRINTED MODEL:.....	59

13.1. Linear Bearing Parameters:.....	59
13.2. Hard and Flexible Material Parameters:	60
14. CONCLUSION:.....	61
15. REFERENCE:.....	62

LIST OF FIGURE

Figure 1:AM process of 3D model to part[1].	9
Figure 2: AM process of 3D model to part[2].....	10
Figure 3: Phases in AM Process[3]	12
Figure 4: Additive Manufacturing technology[4].....	13
Figure 5: Additive Manufacturing Technology using FDM[5]	15
Figure 6: 3D Printer	16
Figure 7: Material Extrusion	17
Figure 8: FDM Extruder Assembly[6].....	18
Figure 9: Nozzle[7]	19
Figure 10: Direct drive and Bowden[7]	20
Figure 11: Layout of Microcontroller	21
Figure 12: Microcontroller[7]	22
Figure 13 :Arduinio[7]	23
Figure 14: Cartesian Coordinate[8]	24
Figure 15: Cartesian [8]	25
Figure 16: 3D Printer	28
Figure 17: Linear Bearing.....	29
Figure 18 Sleeve bearing with flange	31
Figure 19 Iglidur - While Filament[12]	33
Figure 20: Hard and Flexible Material.....	34
Figure 21: Filament of TPE 88 RubberJet	35
Figure 22: Printer Setting- Connection[14]	37
Figure 23: Printer Setting- Printer.....	37

Figure 24 Printer Setting- Extruder.....	38
Figure 25: Printer Setting- Printer Shape[12]	39
Figure 26: Unit Setting[14]	39
Figure 27: Calibration Test 1	40
Figure 28: Calibration Test 2	41
Figure 29: Calibration Test 3	42
Figure 30: Repetier- Host Home Page	43
Figure 31: Load Printed object	44
Figure 32: Object Placement- One Part	44
Figure 33: Object Placement- 4 Object.....	45
Figure 34 Slice with PursaSlicer.....	46
Figure 35 Printer Preview- Without Ooze Shield.....	46
Figure 36: Printer Preview- With Ooze Shield.....	47
Figure 37: Printer Preview- 4 Object	47
Figure 38: Object Placement-Hard and Flexible Material	48
Figure 39: Print Preview- Hard and Flexible Material	49
Figure 40: Linear Bearing- Test 1.....	50
Figure 41: Linear Bearing- Test 2.....	51
Figure 42: 3D model of Brush and Holder	52
Figure 43: Brush and Holder.....	53
Figure 44: New Brush and Rubber Holder- 3D model	53
Figure 45: Brush and Rubber Holder.....	54
Figure 46: New brush and Rubber Holder.....	54
Figure 47: Linear Bearing - Test 3.....	55
Figure 48: Linear Bearing – with Ooze shield.....	56
Figure 49: Skirt Setting.....	56
Figure 50: Linear Bearing - without Ooze Shield.....	57
Figure 51: Hard and Flexible Material- Trail 1	58
Figure 52: Hard and Flexible Material- Trail 2	58
Figure 53: Linear Bearing Parameters	59
Figure 54: Measurement using vernier caliper	59

Figure 55: Parameters 60

Figure 56: Measurement using vernier caliper 60

LIST OF TABLE

Table 1: Pros and Cons 26

Table 2 Linear Bearing Parameter 30

Table 3 Pros and Cons of PLA 30

Table 4 Temperature Requirement 30

Table 5 Iglidur 1150- Specification[12] 32

Table 6: Hard and Flexible Material Parameter..... 34

Table 7 Printer Configuration 36

Table 8: Firmware Setting Test 1..... 40

Table 9: Firmware Setting Test 2..... 41

Table 10: Firmware Setting Test 3..... 42

LIST OF SYMBOL AND ABBREVAITION:

FFF - Fused Filament Fabrication.

FLM - Fused Layer Manufacturing

PLA – Polyactide

TPU - Thermoplastic Polyurethane

AM - Additive Manufacturing

SLA - Stereo lithography

SGC - Solid Ground Curing

UV – Ultra Violet rays

DLP – Digital light Processing

FDM - Fused Deposition Modelling

LOM – Laminated Object Manufacturing

TIJ – Thermal Inkjet

SLS – Selective Laser Sintering

SLM – Selective Laser Melting

3DP – Three Dimensional Printing

CAD – Computer Aided Design

STL - Standard Triangle Language

°C – Degree Celsius

Sec – Seconds

mm- Millimeter

TPE- Thermoplastic Elastomer

1. INTRODUCTION:

The Diploma Thesis title is “**Dual-Material 3D Printing Using FLM Additive Technology**” which is trail in “REBEL II”. FLM technology is applied in REBEL II. Fused Layer Manufacturing is one of the system of Additive Manufacturing technology. Stratasys Inc. was founded in 1989 in Delaware and developed the company’s AM system based on Fused Layer Modelling is also known as Fused Deposition Modelling (FDM) technology. Scott Cramp invented the technology in 1988, and a patent was granted in the United States in 1992. To create 3D models, FDM employs an extrusion process. Pasty strings are deposited layer by layer is called Fused Layer Modelling. The process works with prefabricated thermoplastic material. Colored parts are obtained when colored material is utilized. Technically, FLM is an extrusion process. The part need support during the build. The most popular ones FLM are the BFB3000, fabber 1, Rapman and RapRap. Most frequently, Polyactide (PLA) and Acrylonitrile butadiene styrene (ABS) are used for Fused Layer Modelling.

Before anything else, First portion of the proposition include the calibration of the two nozzle while printing different material such as PLA, TPU and Iglidur. The calibration improves the quality of the whole print as the nozzle adjust in same line.

Second portion of the thesis to be determination by the very compact test and calibration model for printing. When small string of plastic left behind on a 3D printing model, stringing is also known as oozing. Our main goal to make the calibration test as tiny and effective as possible.

2. AIM OF THE THESIS:

The main objective of the state is to get familiar with the 3D printer REBEL II with dual head and research on material and printing measurements of FLM technology, o test the two components printing on the 3D printer Rebel II, based on FLM technology. Printed parts will be from two different materials (e.g. ABS and TPU, PLA and Iglidur, etc.). Design the setting of printing parameters procedure, and if necessary, make changes in the printer design. The main aim of this thesis is to improve the quality of the print.

3. ADDITIVE MANUFACTURING:

Additive Manufacturing (AM) is formerly known as Rapid prototyping (RP). In contrast to subtractive manufacturing approaches, additive manufacturing is a "process of joining material to produce items from 3D model data, usually layer by layer". Additive manufacturing is a rotating, automated process based on the layer-based technological premise. It is distinguished by a chain that is depicted. It begins with a 3D CAD data set that represents the part that will be manufactured.

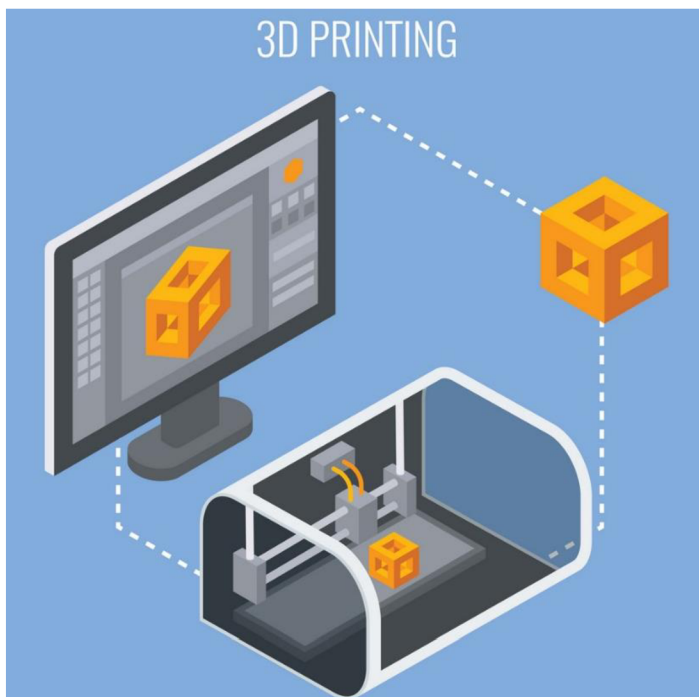

Figure 1:AM process of 3D model to part[1].

3.1. The Generic AM process:

AM requires a number of steps that shift from the definition of the virtual CAD to the physical component arising from it. Different items can include AM in various forms and to various degrees. AM can only be used for visualization models in small, relatively basic goods, but larger, more difficult products with significant engineering content may require AM through numerous phases and iterations. The AM procedure necessitates the completion of eight phases.

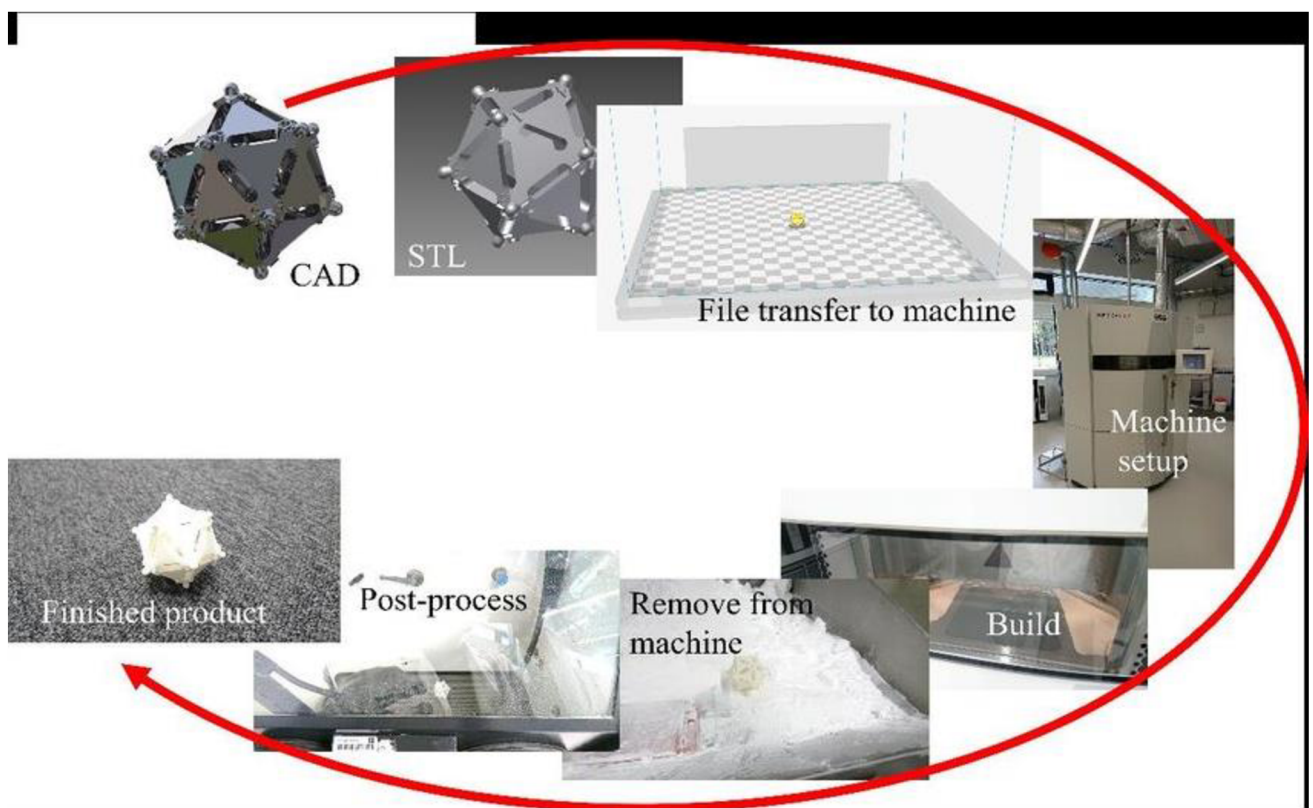

Figure 2: AM process of 3D model to part[2]

- Step 1 : CAD
- Step 2 : CAD model to STL
- Step 3 : File transfer to machine
- Step 4 : Machine setup
- Step 5 : Build
- Step 6 : Remove from machine
- Step 7 : Post-process
- Step 8 : Finished product

Step 1: CAD

AM parts must start from software model that fully describes the external geometry.

Step 2: CAD model conversion to STL

The STL file format, which has become a standard is accepted by Additive Manufacturing machines, and almost every CAD system can generate it.

Step 3: File transfer to machine

The STL file describing the parts must be transfer to the Additive Manufacturing Machine.

Step 4: Machine setup

Prior to beginning the build process, the Additive Manufacturing machine must be correctly set up. Such as criteria might include material restrictions, energy supply, layer thickness, and time, among others.

Step 5: Build

The process of making the part is large automated, and the machine can work without supervision for the most part.

Step 6: Removal

Additive manufacturing machine has completed the construct and the parts must be removed.

Step 7: Post-processing

Parts have been taken from the machine may require some additive cleaning before they are ready for use.

Step 8: Finished product

Parts may be ready to use, or they may need extra treatment before they can be used.

3.2. Benefit of Additive Manufacturing:

- Inexpensive
- High-volume manufacture
- Waste reduction
- Exceptional quality
- Accessibility
- Sustainability

3.3. Classification of Additive Manufacturing technology:

There are a few different classification systems for AM techniques, including one established by the American Society for Testing and Materials (ASTM), which divides them into seven categories. The state of the starting material can also be used to classify AM processes.

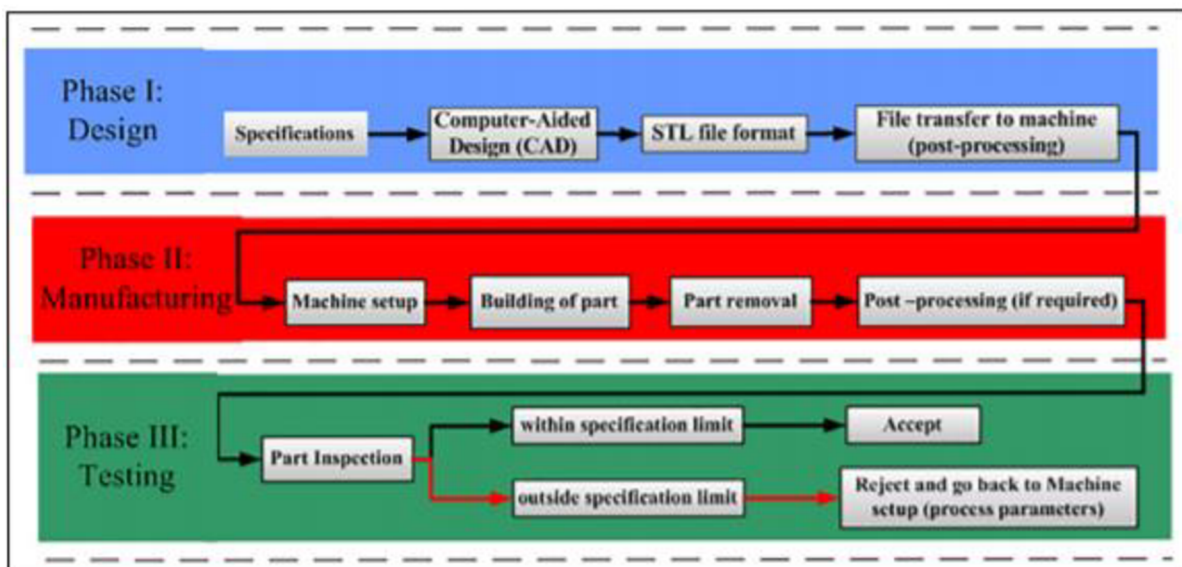

Figure 3: Phases in AM Process[3]

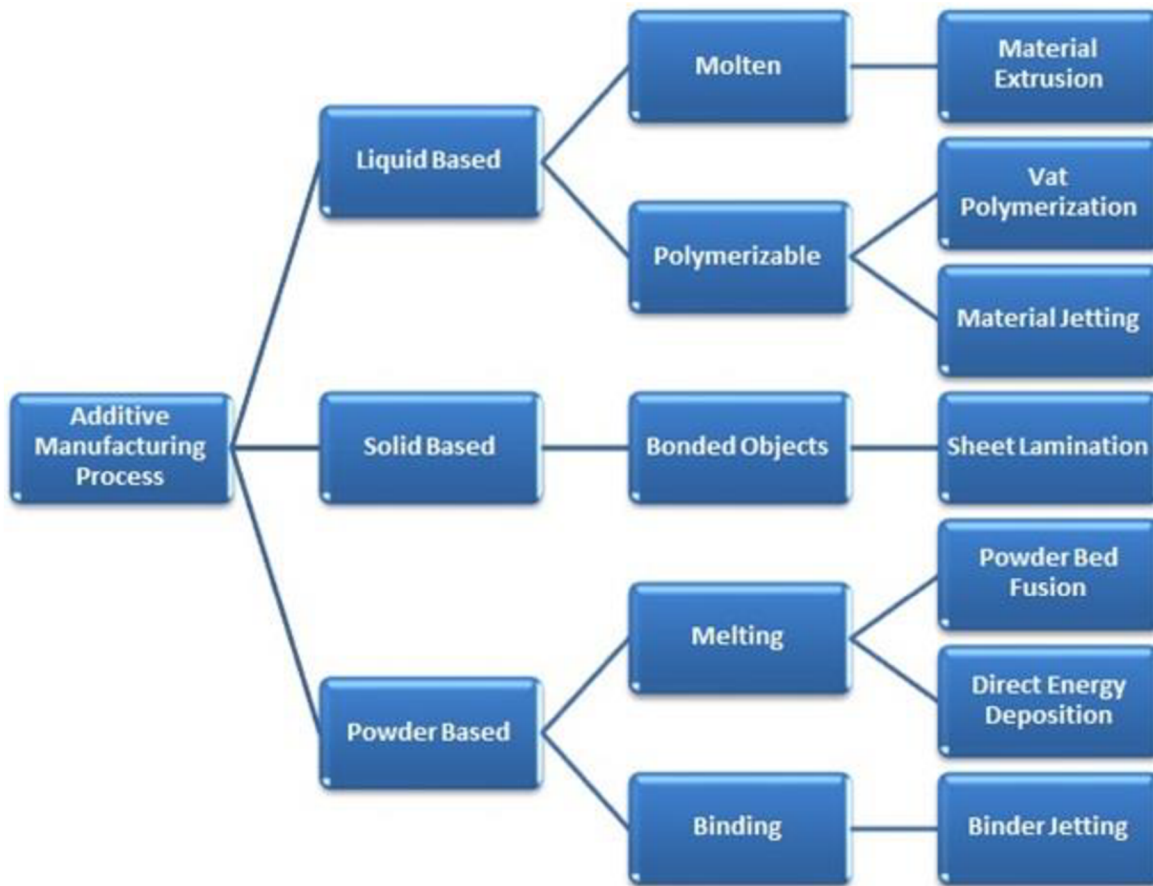

Figure 4: Additive Manufacturing technology[4]

3.3.1. Powder Bed Fusion:

Description: Thermal energy is selectively fuses regions of a powder bed.

Related Technologies: Electron Beam Melting (EBM), Selective Laser Sintering (SLS), selective Heat Sintering (SHS), Direct Metal Laser Sintering (DMLs).

Material Used: Metals and Polymers.

3.3.2. Directed Energy Deposition:

Description: Focused thermal energy is used to fuse materials by melting as the material is being deposited.

Related Technology: Laser metal Deposition (LMD)

Material Used: Metals

3.3.3. Material Extrusion:

Description: Material is selectively dispensed through a nozzle.

Related Technology: Fused Deposition Melting (FDM)

Material used: Polymers

3.3.4. Vat Photo Polymerization:

Description: Liquid photopolymer in a vat is selectively cured by light- activated or UV polymerization.

Related Technology: Stereolithography (SLA), Digital Light Processing (DLP).

Material Used: Photopolymer.

3.3.5. Binder Jetting:

Description: A liquid bonding agent is selectively deposited to join powder materials and then product is baked in an oven for final curing.

Related Technologies: Powder Bed and Inkjet head (PBIH), Plaster-based 3D printing (PP).

Material Used: Polymers, Sand, Metals and other.

3.3.6. Material Jetting:

Description: Droplets of build material are selectively deposited

Related Technology: MultiJet Modelling (MJM).

Material Used: Polymers, Waxes.

3.3.7. Sheet Lamination:

Description: Sheets of material are bonded to form an object.

Related Technology: Laminated Object Manufacturing (LOM), Ultrasonic Consolidation (UC).

Material Used: Paper, Metals

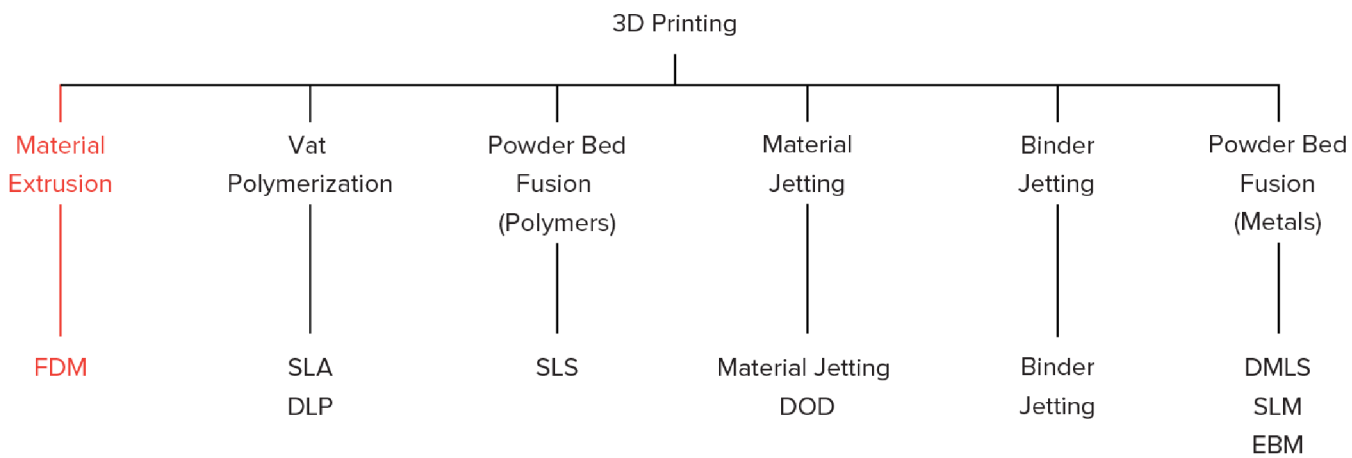

Figure 5: Introduction of FDM 3D printer [5]

3.4. Fused Deposition Modelling-(FDM)

The principle of FDM technology (fused Deposition modelling) is also known as Fused Layer Modelling (FLM). In FDM, a parts is constructed by selectively depositing melted material in a pre-determined path layer-by-layer is called Fused layer Modelling. By heating thermoplastic material to a semi-liquid state and extruding it along computer-controlled paths, FDM technology creates parts layer by layer. FDM used two materials to execute a print job: modelling material and scaffolding support for the finished product. Materials filament are fed from the 3D printer's material bays to the print head, which travels in X and Y coordinates, depositing material to finish each layer before the base travels down the Z- axis and the next layer begins.

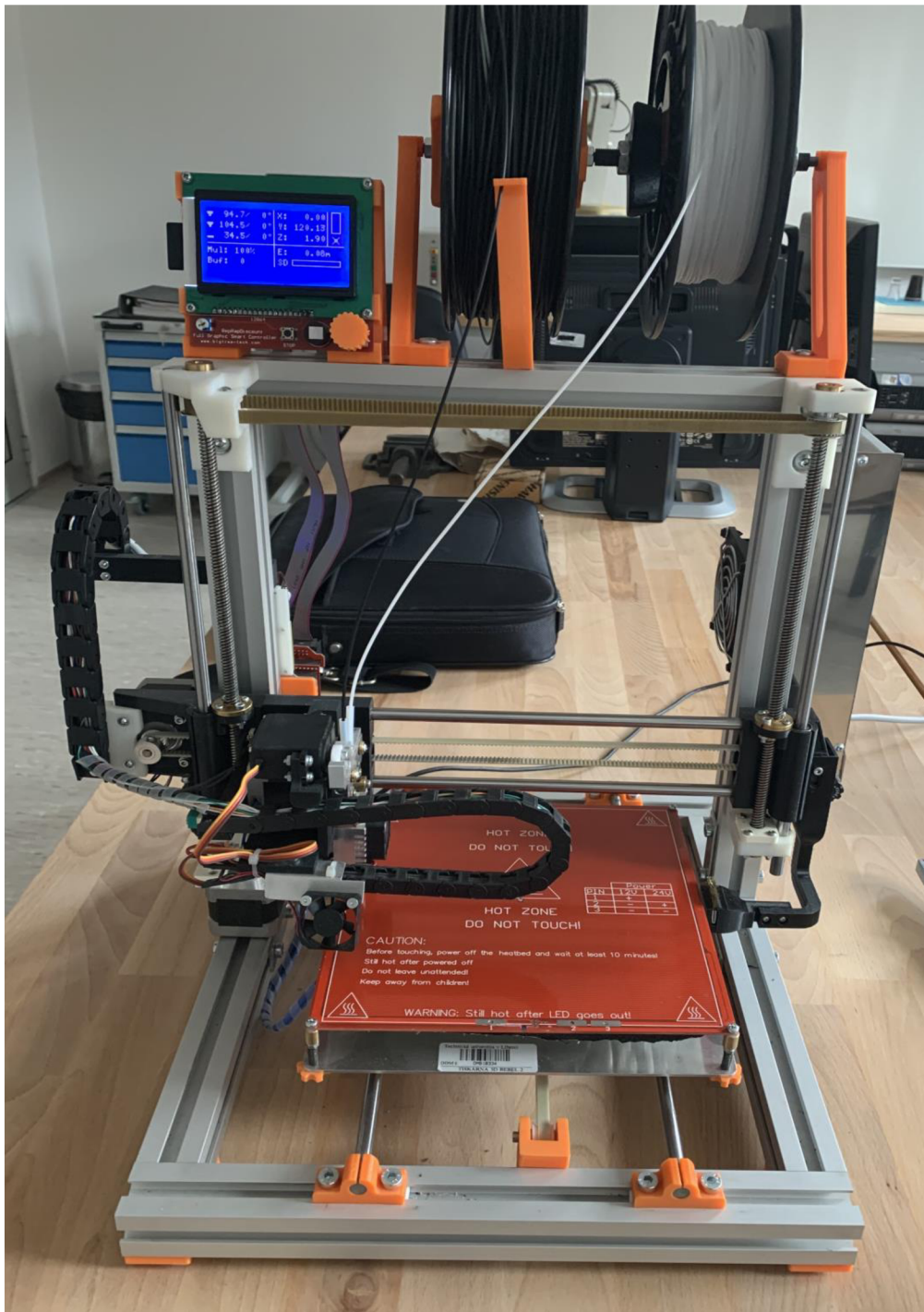

Figure 6: 3D Printer

4. PARTS OF FDM 3D PRINTER

4.1. Material Extrusion:

Fused Layer Modelling where a feedstock material is forced through an extruder, uses material extrusion to print products. The feedstock material comes in the form of a filament wound on a spool in most 3D printing machines for fused Layer Modelling. The component primarily used in this type of printing is the 3D printer. Extruders have a cold end and a hot end for these printers. The cold end uses the material's gear- or roller-based torque to extract material from the spool, and a stepper motor controls the feed rate.

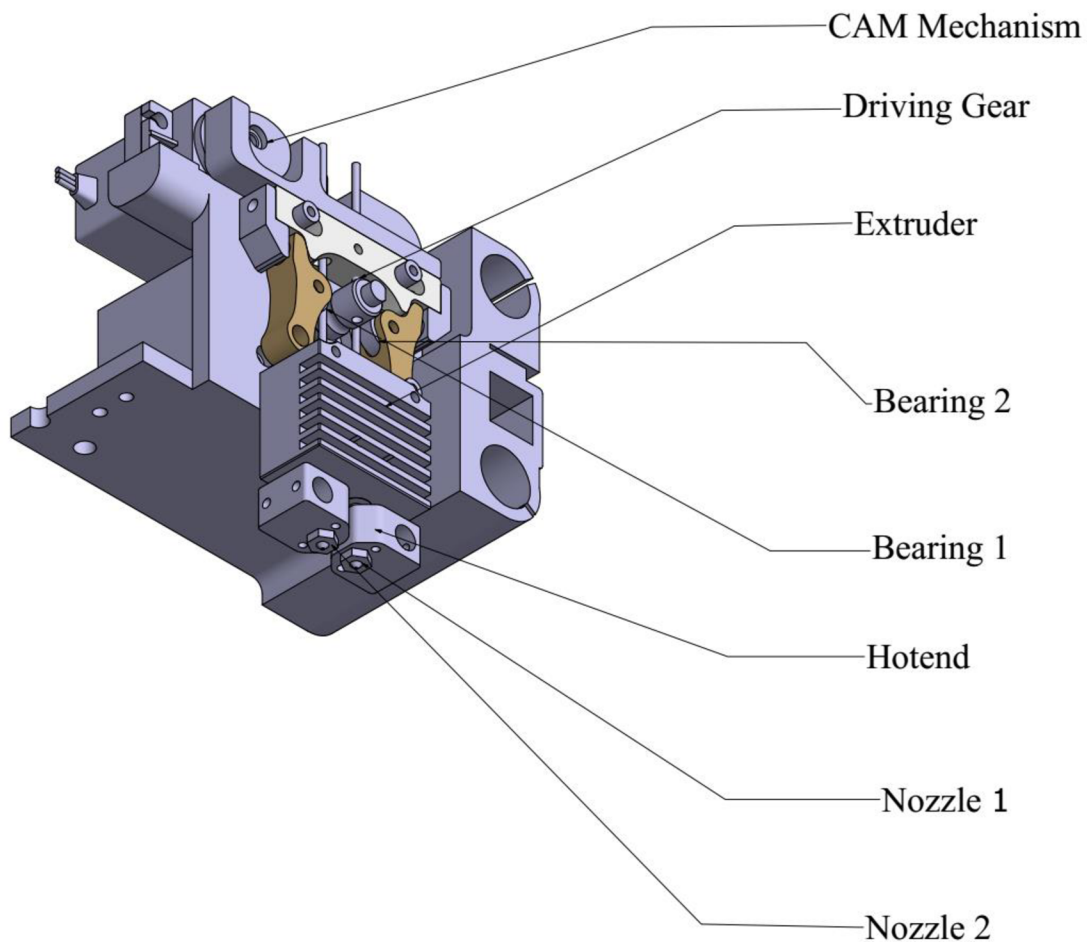
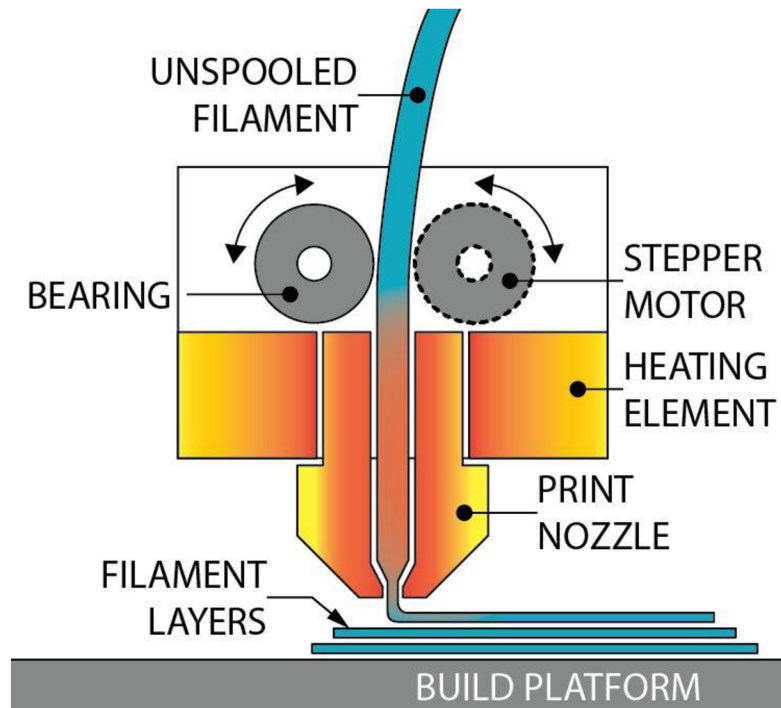

Figure 7: Material Extrusion

Filament is led to the extruder. To feed and retract the filament precisely, the extruder uses torque and a pinch system. The filament is melted to a usable temperature using a heater block. The heated filament is driven out of a smaller diameter heated nozzle. The extruded material is placed where it is needed on the model. The print head and platform bed is moved to the correct X/Y/Z position for placing the material.



FDM EXTRUDER ASSEMBLY

Figure 8: FDM Extruder Assembly[6]

4.2. Nozzle:

The nozzle gives the diameter with which the material will be extruded. When used in the context of painting, it refers to the brush that is used to apply paint to the layers. It is required to distinguish nozzles for 1.75mm filament. Nozzles of various materials can be found, just as the heater block. For the most part, brass nozzles are used because they are less expensive. There are nozzles with various threads that can be used with various extruder models. With finer nozzles, you can make smaller details. You may extrude more material in a single pass and print faster with larger nozzles[7].



Figure 9: Nozzle[7]

Types of Extruder:

There are many variety of extruders on the market. You must understand what to use filament of 1.75mm to 3 mm.

The filament diameter must be conditioned in both the thermal bar and the nozzle. It's also the component that pushes the filament. The types of extruders are listed below.

1. Direct drive
2. Bowden

4.2.1. Direct drive or direct extrusion:

Direct extrusion extruders are a development of gear extruders. The term "direct extrusion" refers to the filament being pushed directly by the motor. On the motor shaft, a toothed pulley, also known as a "Hobbed pulley," is installed. The teeth on this pulley drive the filament forward. A bearing is utilized on the other side of the filament to apply pressure and ensure that it does not slip.

The most significant benefit of this type of extruder is that it takes up less room. It is mainly used in filaments of 1.75 since these require less force to be pushed[7].

4.2.2. Bowden:

The Bowden extruder is an alternative that is typically utilized in delta printers. Both a direct extrusion mechanism and gear can be carried on a Bowden extruder. The distinction is that a PTFE tube separates the hotend driving mechanism.

Only have to shift the hotend this way, not the complete engine. It is feasible to significantly lower the weight of the printer, allowing it to print at higher rates. It also makes changing the Hot End a lot easier.

The biggest issue arises when attempting to control the filament's push. It's more difficult to regulate when the point that pushes the hardest is distanced from the point that generates resistance.

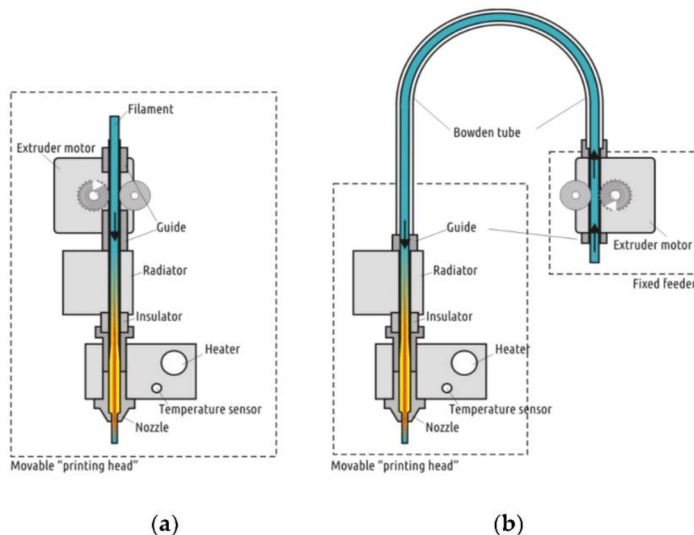

Figure 10: Direct drive and Bowden[7]

4.3. Structure:

In 3D printing, the structure is the component that connects all of the printer's parts and allows the axes to move.

Different structures allow for different movements, but having a robot structure is critical. The extruder is always positioned downwards and can be moved in three axes in relation to the printing surface (3 dimension). Linear movements, one for each axis, can be used. Also, rotary movements or a mixture of linear and rotational motions.

4.3.1. Cartesians printer:

The Cartesian coordinate system, which the printers employ for movement, gives them this name. In a Fused Deposition Modelling (FDM) 3D printer, they are the most prevalent sort of structure. The X-axis is used to move right and left, the Y-axis is used to move up and down, and the Z-axis is used to move forward and backward.

4.4. Electronics:

It is necessary to employ an electronic circuit that interacts with the environment and includes sensors and actuators.

- A sensor is a device that detects physical or chemical quantities and converts them to electrical information.
- An actuator works in the other direction, generating physical or chemical magnitude from an electrical signal. An electric motor, for example, is a device that converts electricity into motion.

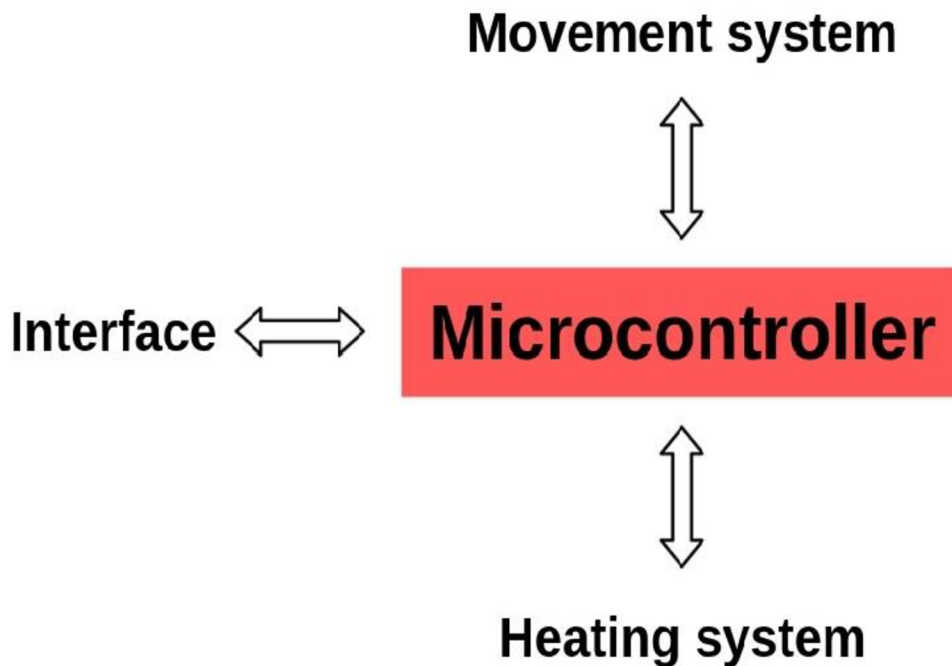

Figure 11: Layout of Microcontroller[7]

- Microcontroller: It's a programmable integrated circuit that can carry out the commands stored in its memory. That is the printer's brain.
- Heating system: The printer has a resistance as actuators to heat the extruder and a heated bed. The temperature of these parts is measured using temperature sensors.
- Movement system: The minimum will be one motor for each axis and another for the extruder. The movement part uses sensor to determine its current position. The most common are the end of a career.
- Interface: It is the part of the electronics that allows the user to exchange information with the printer. The most used are the end of a cancer.

4.4.1. Microcontroller:

Using an Arduino Board and a Ramps module is the easiest and most cost-effective option in open source.

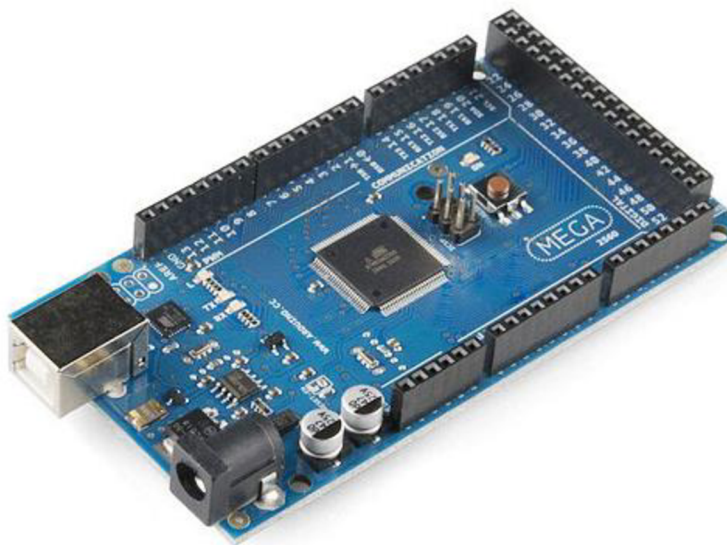

Figure 12: Microcontroller[7]

The plates Arduino is working on plates, as well as a microcontroller with inputs and outputs.

4.4.2. Arduino:

An arduino board is a wonderful alternative for any project that requires electronic components. The Arduino Due Model is employed in the case of 3D printers. The Ramps module is an adaption plate or shield that is attached to the Arduino's top directly.

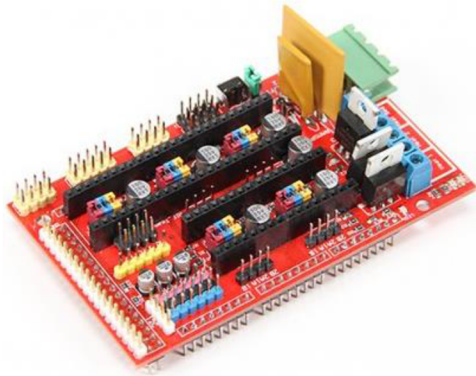

Figure 13 :Arduinio[7]

The microcontrollers work at 5 volt the same “electricity” that goes through a USB. In order to shift the motor and to be able to heat up as this requires more electricity the input and output signals have to be adapted[7].

4.5. Structure

In 3D printing, the structure is the component responsible for joining all the parts of the printer and allows the axes to move.

Different structures allow for different movements, but it is very important to have a strong structure. A weak structure transfer vibrations and forces printing at low speeds.

A 3D printer is a portable device that satisfies certain requirements. The extruder is always positioned downwards and can be moved in three direction in relation to the printing surface (3 dimensions).

It is possible to move the extruder in a variety of ways. Linear movements, one for each axis, can be used. Also, rotational movements or a mixture of linear and rotary.

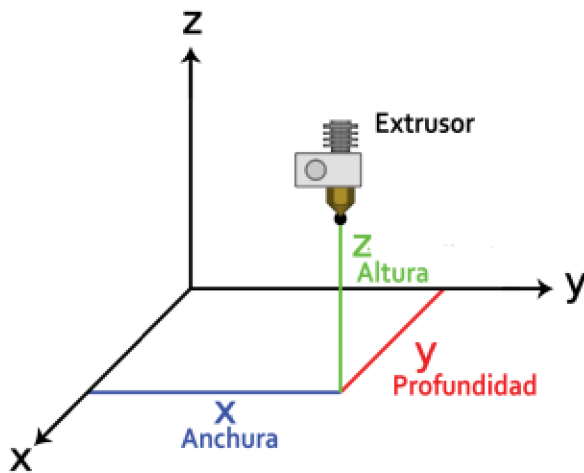

Figure 14: Cartesian Coordinate[8]

4.5.1. Cartesian printer:

The Cartesian coordinate system, which these printers use for movement, gives them this name. In fused deposition modeling (FDM) 3D printers, they are the most prevalent sort of structure.

To position the extruder, they use linear movements. Straight movements are used to move the extruder from left to right or from front to back (X axis and Y axis). To vary the height, move the printing surface instead of adjusting the extruder.

Cartesian printers have the advantage of being more intuitive. A movement failure is easy to identify. If the X-axis fails, for example, you will immediately see that the extruder does not travel from left to right. The structures are scalable, but keep in mind the force relationships. To put it another way, if I construct a larger printer, I'll need bigger shafts and motors that can generate more force because they'll be moving more weight. Another benefit is that you can create structures that can generate a lot of force in the tip; most CNC three-axes employ structures like this.

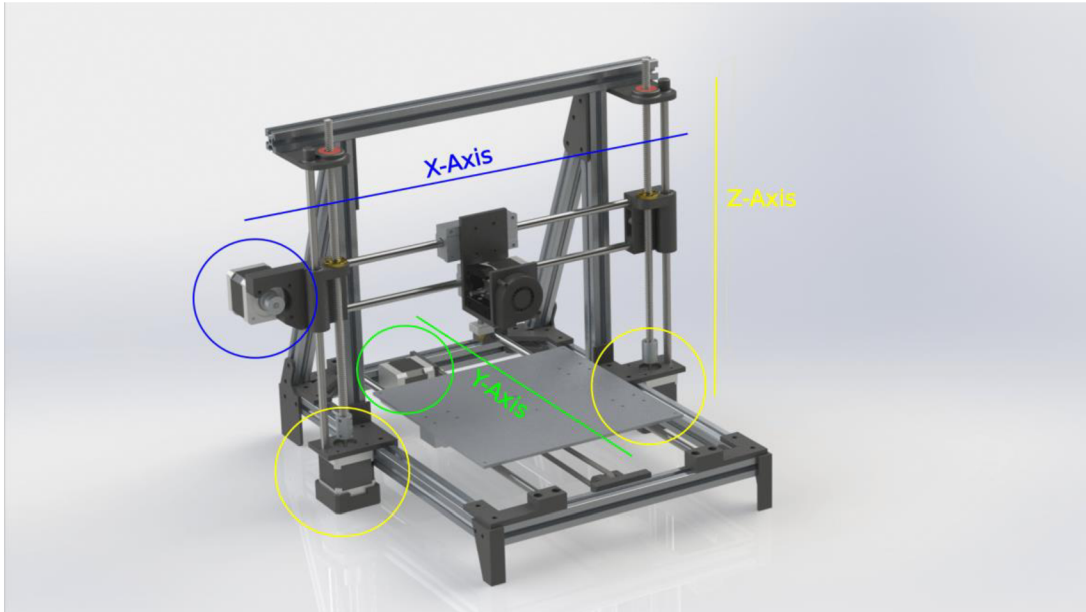

Figure 15: Cartesian [8]

5. COMPARING MM 3D PRINTER AND REBEL II:

5.1. PRUSA MNU 2.0:

MMU2S stands for Multi Material Unit, this is their improved version 2 of their product. This device allows Prusa printers can use 5 different filaments with one nozzle and extruder assembly. This means that you only need one nozzle and only one extruder on your X direction.

5.1.1. Prusa MNU 2.0 concept:

The Original Prusa MK3S, the company's current flagship 3D printer, and its predecessor, the Original Prusa MK2.5S, are the basic 3D printers to which this update can be done. The device is changed into a different 3D printer in either circumstance; they require distinct slicing treatment and must be selected as such in the software. In other words, if you use the MMU2 kit to update an MK2.5S, you no longer have an MK2.5S; you now have a “MK2.5S MMU2”. The concept here is to use different filaments within a print job to create multi-material capability, as both of the base 3D printers are filament-powered machines. However, because the device only has one nozzle, a mechanism to replace filaments on the fly is required. The Prusa MMU improvements are based on this principle [9].

5.1.2. Pros and Cons- Printers:

	Prusa MNU 2.0	REBEL II	Pursa MKS
Type of Extruder	Bowden	Direct Extrusion	Direct Extrusion
No. of Nozzle	Single Nozzle	Two Nozzles	Single Nozzle
Area Covered	Entire	Partial	Entire
Problem	<ul style="list-style-type: none"> • It take time to unload the material and load the material. • Flexible Material 	<ul style="list-style-type: none"> • The Retraction doesn't always work on 100%. • Filament leftover get struck on the printed part 	It take time to unload the material and load the material.
Filament	<ul style="list-style-type: none"> • 5 filament(same material) • Nozzle temperature are same throughout the procedure 	<ul style="list-style-type: none"> • 2 filament (Different material) • Nozzle temperature are vary by material 	2 Filament (same material) and same temperature

Table 1: Pros and Cons

5.2. 3D PRINTER GEEETECH A10T:

It has basic, durable and compact design and also is easy to assemble. Its stable structure ensure that it will generation high - quality prints. It also features a lot more refined design and individual components.

5.2.1. Specifications:

- Print capacity: 220x220x260 mm
- Layer resolution: 0.1 - 0.3 mm
- Printing string diameter: 1.75 mm
- Nozzle diameter: 0.4 mm
- Positioning accuracy: X / Y: 0.011mm. Z: 0.0025mm

5.2.2. Pros and cons- Printers:

	REBEL - II	Geeetech A10T
Print technology	FDM	FDM
Number of Nozzle	Dual Nozzle	Single Nozzle
Temperature	110°C - 280°C	110°C - 250°C
Type of extruder	Direct Extrusion	Bowden Extrusion
Problem	The Retraction doesn't always work on 100%.	It take time to unload the material and load the material.
Filament	<ul style="list-style-type: none"> • 2 Filament (different material) • Set the various temperature during the process 	2 Filament (same material) and same temperature throughout the process

Table 1: Pros and Cons

6. PRACTICAL WORK:

6.1. Rebel II- Printer – Dual Extruder:

Rebel II printer is a Dual extruder 3D printer. It has two print nozzles, rather than a single print nozzle on standard FDM 3D printers. Rebel II is a small printer having a print area of 200x200x140 mm. It is made up of two independent nozzles that may operate independently since each one is equipped with extruder gears that produce extrusion pressure. Input for the Rebel II is provided either by a computer connected by the USB connection available or by SD card which can be directly connected to the printer itself. The input files should be in STL format to be read by the printer. Repetier Host is in charge of the printer's inputs and manual controls. The table below shows the printer specifications, which include federate and permissible temperature [8].

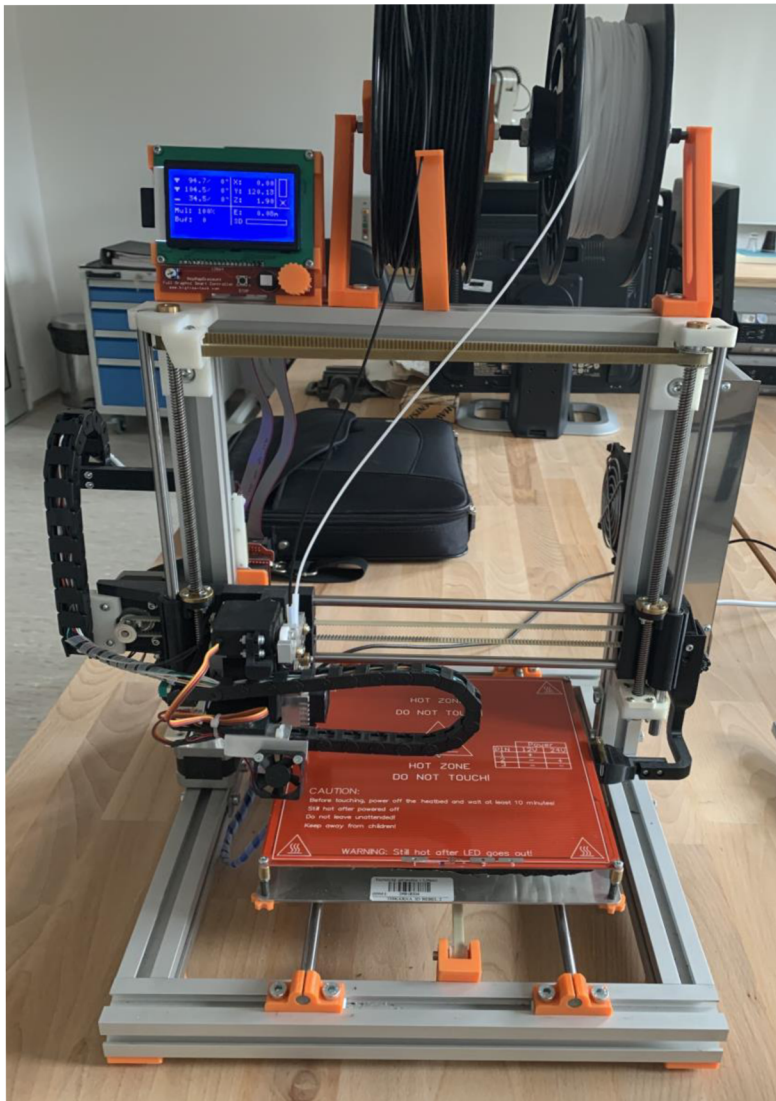

Figure 16: 3D Printer

6.2. Rebel II Dual Printer- Advantage:

Dual printing the constraints of using only one type of 3D printer filament and allows to easily build colorful parts. Dual head 3D printing allows to print multi-color parts and increases support printing with soluble supports like HIPS and PVA.

Extruders with two heads we cover more advanced printers as well as twin nozzle printers, which have two nozzles but extrude from a single head.

6.3. Benefits of a REBEL II -dual extruder 3D printer:

6.3.1. Better for supports:

Better for support is to have one extruder print your desired material, such as ABS or PLA, while the other extruder prints water-soluble supports, such as PVA filament. These supports dissolve quickly in water, resulting in smoother prints that don't require manual removal.

6.3.2. Multiple colors:

Dual filament has many colors. For a spectacular multi-colored item, 3D printers may print many colors of the same filament type, such as PLA filament.

6.3.3. Multiple parts simultaneously:

It can print multiple components at once. These printers have two extruders that function independently and can print different pieces at the same time [10].

6.4. 3D Model - Linear Bearing:

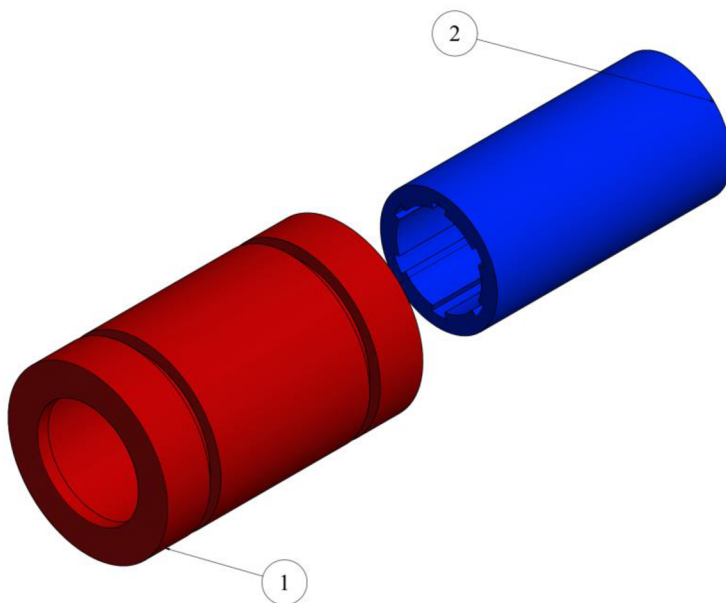

Figure 17: Linear Bearing

In most important industrial applications, linear sliding bearings are used. Because they generate far more friction than roller bearings, they can run at much greater speeds and use a smaller or bigger motor and driving system.

INDEX	PART NUMBER	MATERIAL	QTY
1	OUTER BODY	PLA	1
2	INNER BODY	IGLIDUR	1

Table 2 Linear Bearing Parameter

6.4.1. Outer Body Material- PLA:

Polyactic acid, also known as PLA, is one of the most widely used materials in desktop 3D printing. Because it can be produced at a low temperature and does not require a heated bed, it is the default filament for most extrusion-based 3D printers. PLA is an excellent initial material to use while learning about 3D printing because it is simple to print, affordable, and produces parts that can be used for a number of purposes. It's also one of the most eco-friendly filaments on the market right now. PLA, which is derived from corn and sugarcane, is renewable and, most importantly, biodegradable [11].

PROS	CONS
<ul style="list-style-type: none"> • Low Cost • Stiff and good strength • Good dimensional accuracy • Good shelf life 	<ul style="list-style-type: none"> • Low heat resistance • Can ooze and may need cooling fans • Filament can get brittle and break • Not suitable for outdoors (sunlight exposure)

Table 3 Pros and Cons of PLA [11]

Bed Temperature	45-60°C
Extruder Temperature	190-220°C

Table 4 Temperature Requirement

6.4.2. Inner Body Material- Iglidur:

Igus developed the Iglidur material, which is constructed of high-performance polymers.

6.4.2.1. Iglidur material consist of three components:

- Base polymer
- Fibers and filler
- Solid lubricants

6.4.2.2. Properties:

- Extremely wear-resistance
- Robust
- Self-lubrication



Figure 18 Sleeve bearing with flange [12]

6.4.2.3. 3D printer filament: Iglidur® |150-PF:

Components manufactured of igus® Tribo-Filament are up to 50 times more wear-resistant than ordinary 3D printing materials, resulting in a significantly longer service life. They're ideal for 3D printing replacement parts including bearings, drive nuts, gears, and other worn parts because of their outstanding tribological qualities. The igus® Tribo-Filaments can be printed on 3D printers that employ the fused-deposition-modelling method (FDM/FFF) and have the ability to adjust the nozzle temperature [12].

6.4.2.4. Typical application areas

- Special machine construction
- Jig construction
- Complex wear parts

6.4.2.5. Iigus® adhesive film is required for a non-heated print bed.

- Food compliant
- Tribo-filament that is easiest to process
- High abrasion resistance at low surface speeds
- Good mechanical coefficients
- Cost-effective
- Compliant with EU Regulation 10/2011

Nozzle temperature (min.)	240 °C
Nozzle temperature (max.)	250 °C
Bed temperature (min.)	20 °C
Bed temperature (max.)	60 °C
Max. long-term application temperature	65 °C
Max. short-term application temperature	75 °C

Table 5 Iglidur 1150- Specification[12]



igidur® I150-PF

igus

Figure 19 Iglidur - White Filament[12]

6.4.2.6. Advantage:

- Easy to process.
- High abrasion resistance at low surface speeds.
- Good mechanical properties

6.5. 3D Model- Hard and Flexible material:

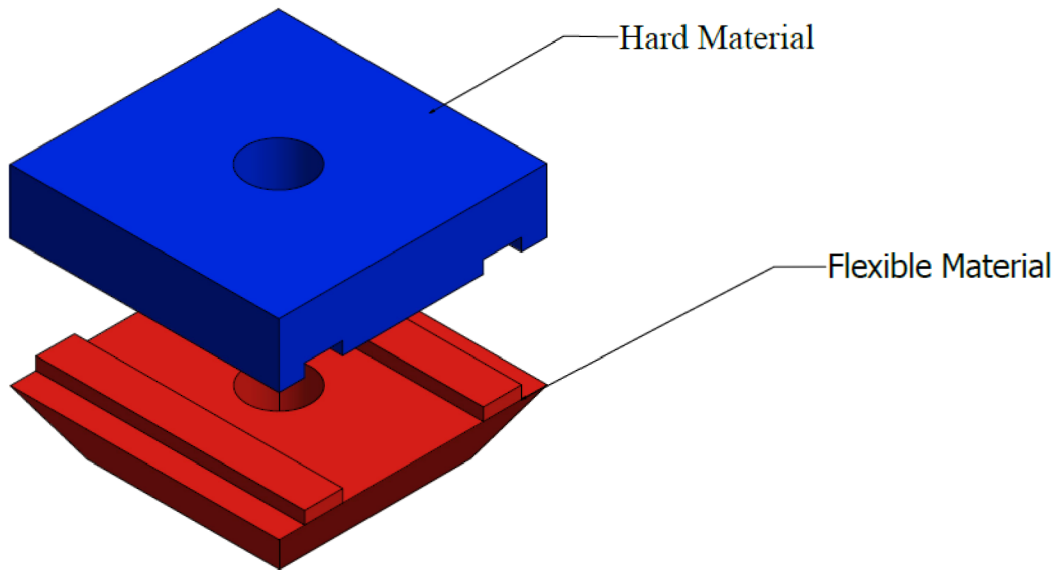

Figure 20: Hard and Flexible Material

INDEX	PART NUMBER	MATERIAL	QTY
1	Hard Material	PLA	1
2	Flexible Material	TPE 88 RubberJet	1

Table 6: Hard and Flexible Material Parameter

6.5.1. TPE 88 RubberJet:

- Material made of polyolefin
- Extremely flexible rubber
- Like material - input material designation 88A → shore 72.5A / 16D (test report)- excellent vibration damping-
- Pressure, shock, chemicals, and water resistance
- Matte appearance
- Non-stick surface is smooth and pleasant to the touch.
- Excellent print
- Very popular material that no macro should miss
- This material has a wide range of applications, and how well you use it is entirely up to you and your imagination [13].

Advantage:

- Printing is simple.
- Doesn't cause the nozzle to clog..
- Flexibility of printed objects.
- Excellent damping of vibrations.
- Pressure, shock, chemicals, and water resistance
- Adhesion of layers.
- Easy to clean.
- Excellent mechanical properties - tensile strength, abrasion resistance[13]

Disadvantage:

- Substrate adhesion is poor.
- Printing issues with printers that use a Bowden extruder [13]



Figure 21: Filament of TPE 88 RubberJet [13]

7. REPETIER-HOST DOCUMENTATION:

7.1. Printer Configuration:

The initial step should be to set up the printer so that the computer can connect to the host. Check to see that the printer is connected and turned on. To access the device, certain printers require a particular driver, therefore ensure the drivers are also loaded. The driver is already installed and uploaded the firmware to the printer.

Go to the menu “Config” ->”Printer Settings” or click the button Printer Settings[14].

Number of Extruder	2
Number of Fan	1
Max. Extruder Temperature	280°C
Max. Bed Temperature	120°C
Max. Volume per second	12 (mm ² /sec)
Extruder 1 Diameter	0.4 mm
Extruder 2 Diameter	0.4 mm

Table 7 Printer Configuration

Port:	COM3	▼
Baud Rate:	115200	▼
Transfer Protocol:	Autodetect	▼
RTS	Low to High	
DTR	Low to High	
Default is Low to High for RTS and DTR. If that does not work try RTS High and DTR Low.		
Reset on Emergency	Send emergency command and reconnect	
Receive Cache Size:	<input type="text" value="127"/>	
Communication Timeout:	<input type="text" value="40"/>	[s]

Figure 22: Printer Setting- Connection[14]

In Port to select the COM3, where the printer is connected. Then I choose the baud rate that was entered into the firmware. Transfer Protocol is communicate with the printer so I select auto-detect. In ASCII mode, all supported firmware function. A binary format is also supported by Repeater-Firmware. The advantage of the binary format are Data size is smaller, Error correction is improved and less computation time. “Auto detect” which will immediately convert to binary format if the Repeater – Host is found.

Printer Settings

Printer: default ▼ 

Connection
Printer
Extruder
Printer Shape
Scripts
Advanced

Firmware Type: Autodetect ▼

Travel Feed Rate: [mm/min]

Z-Axis Feed Rate: [mm/min]

Manual Extrusion Speed: [mm/s]

Manual Retraction Speed: [mm/s]

Default Extruder Temperature: °C

Default Heated Bed Temperature: °C

Figure 23: Printer Setting- Printer

Printer Settings

Printer: default 

Connection | Printer | **Extruder** | Printer Shape | Scripts | Advanced

Number of Extruder:

Number of Fans:

Max. Extruder Temperature:

Max. Bed Temperature:

Max. Volume per second [mm³/s]

Printer has a Mixing Extruder (one nozzle for all colors)

Extruder 1

Name:

Diameter: [mm] Temperature Offset: [°C]

Color:

Offset X: Offset Y: [mm]

Extruder 2

Name:

Diameter: [mm] Temperature Offset: [°C]

Color:

Offset X: Offset Y: [mm]

Figure 24 Printer Setting- Extruder

In the Extruder tab, Values are entered the number of extruder, number of fans, max. Extruder temperature, max. Bed temperature and max. Volume per second. There are 2 extruders in the 3D printer. Extruder 1 is an outer body of the linear bearing and I choose yellow color for print preview. Both nozzle diameter is 0.4 mm. Extruder 2 is an inner body of the linear bearing and I choose blue color for print preview.

In the Printer Shape, Maximum and minimum size of x- axis is 0 mm to 219 mm. Maximum and minimum size of y- axis is 0 mm to 200 mm. print area capacity is 200 x 200 x 160 mm.

Printer Settings

Printer: default 

Connection | Printer | Extruder | **Printer Shape** | Scripts | Advanced

Printer Type: Classic Printer

Home X: Home Y: Home Z:

X Min X Max Bed Left
 Y Min Y Max Bed Front

Print Area Width: mm

Print Area Depth: mm

Print Area Height: mm

The min and max values define the possible range of extruder coordinates. These coordinates can be negative and outside the print bed. Bed left/front define the coordinates where the printbed itself starts. By changing the min/max values you can even move the origin in the center of the print bed, if supported by firmware.

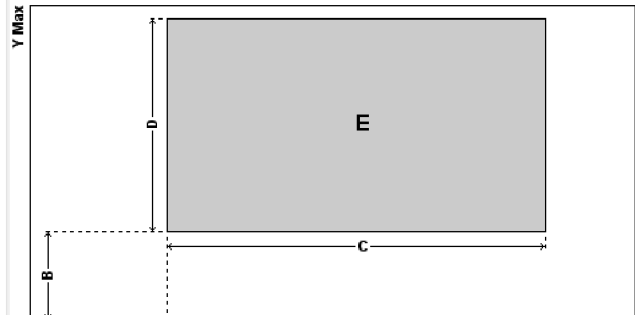

Figure 25: Printer Setting- Printer Shape[12]

7.2. Units Settings:

The Repetier-Host is only used Millimeters. The Repetier-host will convert the units correctly into Millimeters.

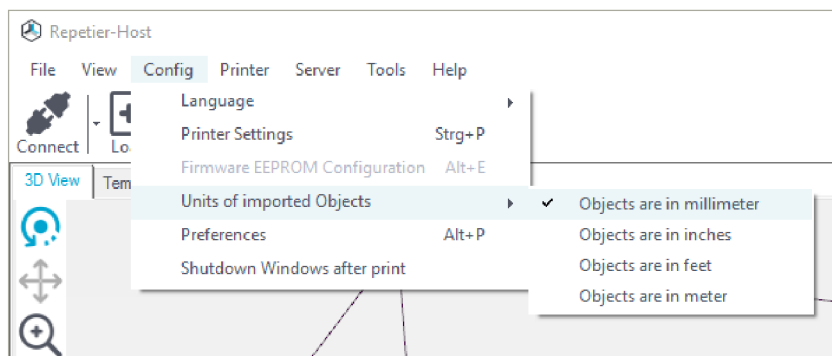

Figure 26: Unit Setting[14]

8. CALIBRATION TEST:

The deviation can only be changed by altering by changing the input in EEPROM Arduino, therefore the g codes used in previous prints remain the same. Various values are assumed and printed, as well as a calibration test. Each layer in the test is printed with both the nozzles, due to the difference in the nozzle position the determined print is not achieved. To test the distance error in the nozzles, the value is adjusted and multiple prints are performed.

8.1. Test 1:

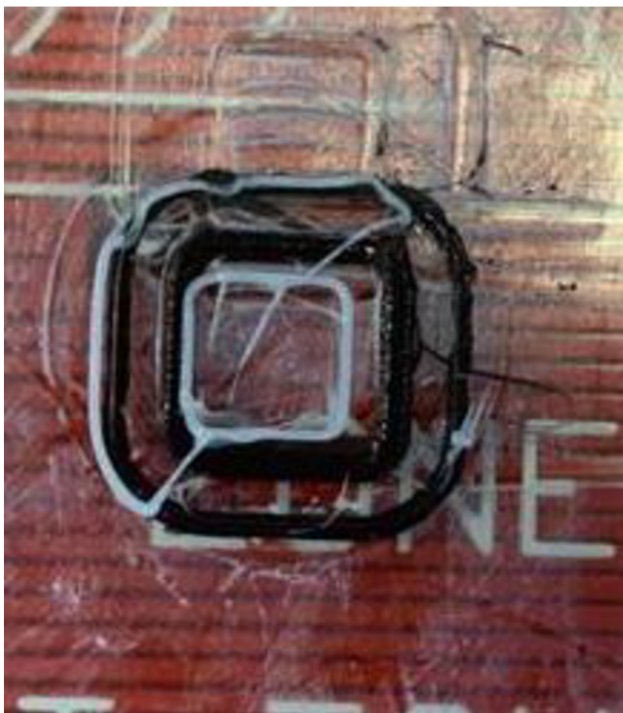

Figure 27: Calibration Test 1

Extruder 1 X- Offset	-140
Extruder 1 Y- Offset	-1600
Extruder 1 Z- Offset	0
Extruder 2 X- Offset	0
Extruder 2 Y- Offset	0
Extruder 2 Z- Offset	0

Table 8: Firmware Setting Test 1

8.2. Test 2:



Figure 28: Calibration Test 2

Extruder 1 X- Offset	-140
Extruder 1 Y- Offset	-1620
Extruder 1 Z- Offset	0
Extruder 2 X- Offset	0
Extruder 2 Y- Offset	0
Extruder 2 Z- Offset	0

Table 9: Firmware Setting Test 2

8.3. Test 3:



Figure 29: Calibration Test 3

Extruder 1 X- Offset	-140
Extruder 1 Y- Offset	-1640
Extruder 1 Z- Offset	0
Extruder 2 X- Offset	0
Extruder 2 Y- Offset	0
Extruder 2 Z- Offset	0

Table 10: Firmware Setting Test 3

9. PRINTING PROCEDURE - Linear Bearing:

The software Repetier-Host is used to operate or provide the input feed for the Rebel II.

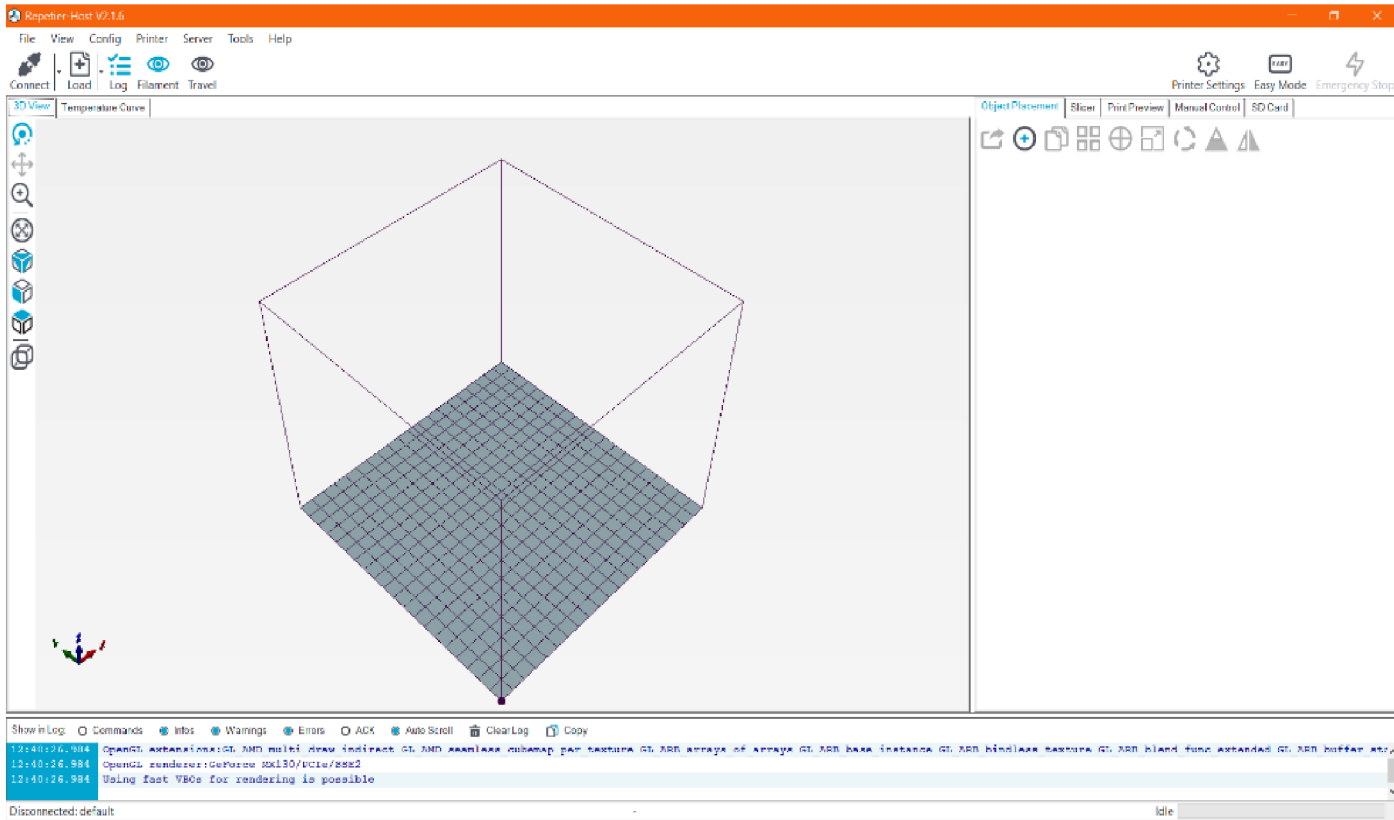

Figure 30: Repetier-Host Home Page

9.1. Load the object:

The software opens the STL (Stereo lithography or Standard Triangle Language) file of the sample to be printed and does the necessary setup. STL files can be created using design tools such as Inventor. For example, in the event of practical work, a cube is created to test the performance of the printer with two nozzles. In order to test the printer, a two-part liner bearing is employed.

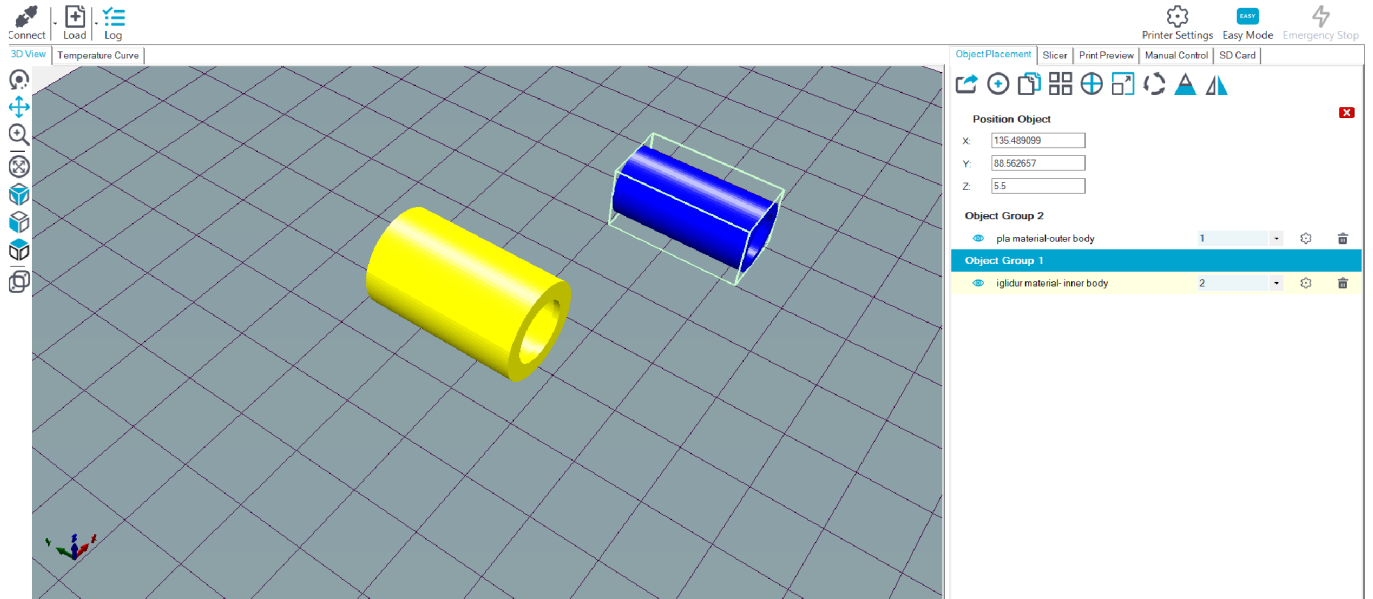

Figure 31: Load Printed object

9.2. Object placement:

The linear bearing is designed as two parts as outer and inner parts as shown in the image. Each part is assigned to different nozzle and placed in center. The workspace shown in the software represents the workspace in the printer. The parts are printed according to the software's instructions, so the two different components are centered or on the same axis. Once components have been aligned, the slicer in the Repetier host is used. Various slicer options are available such as Cura Engine, PuraSlicer and Slic3r. The slicer used for this project is Prusa Slicer.

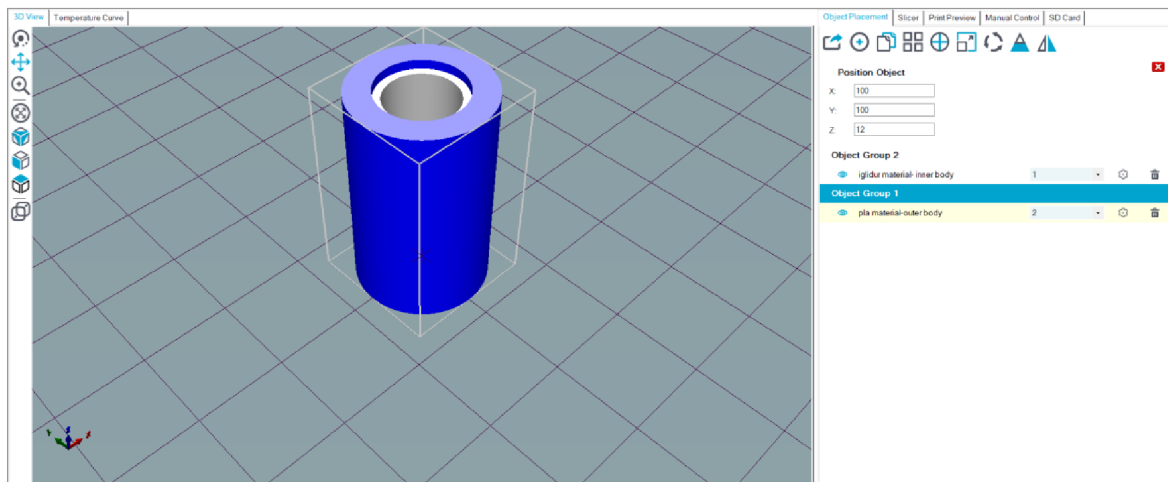

Figure 32: Object Placement- One Part

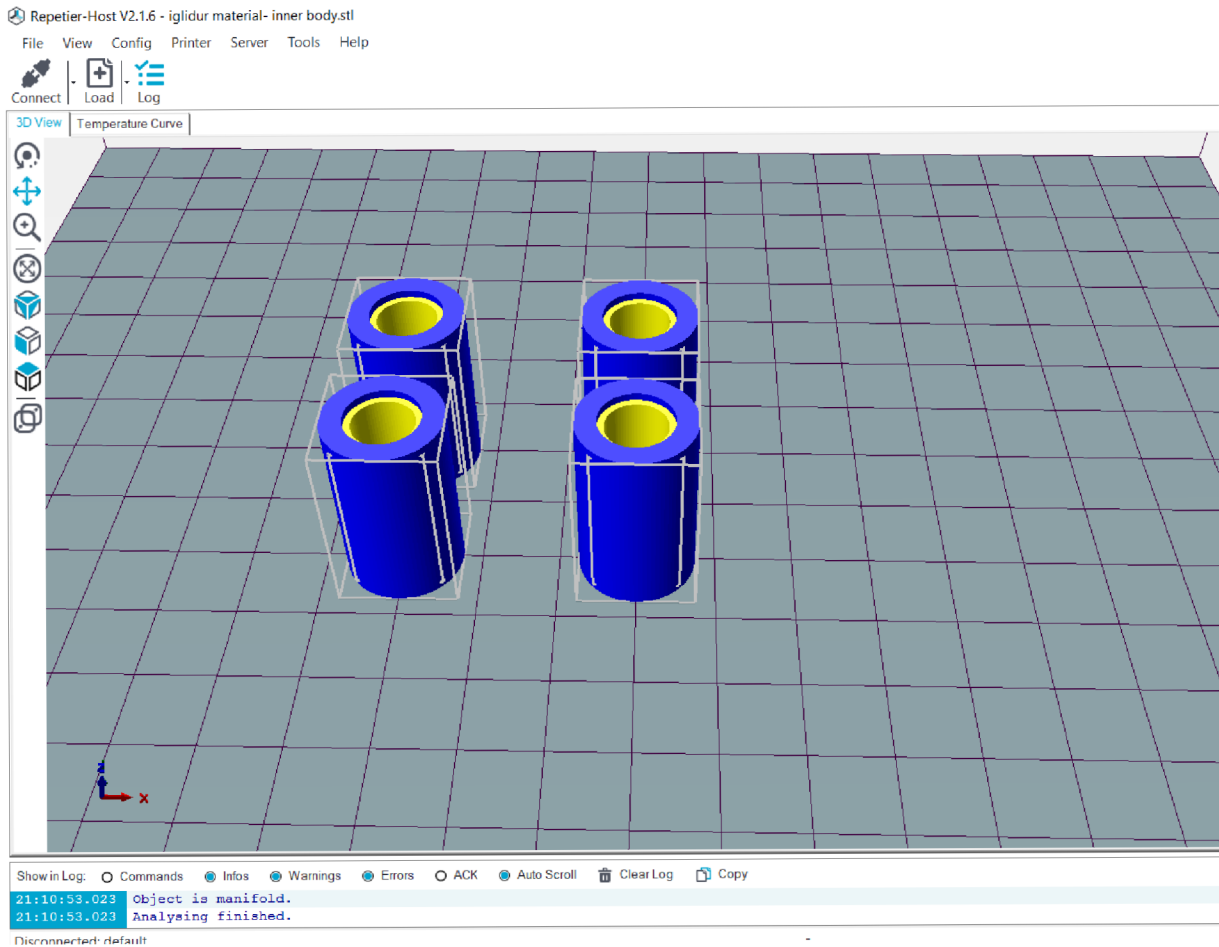

Figure 33: Object Placement- 4 Object

9.3. Slicer:

When the command Slice with PrusaSlicer, Printer setting are changes or altered as per our need in this window. Material density and infill pattern are set according to our specifications. The layer height is also changed. In this case, the layer height is 0.25mm, the infill density is set to 20%, and the infill pattern is honeycomb. Once all parameters are defined slicing in performed and the part is sliced and the resultant model is displayed.

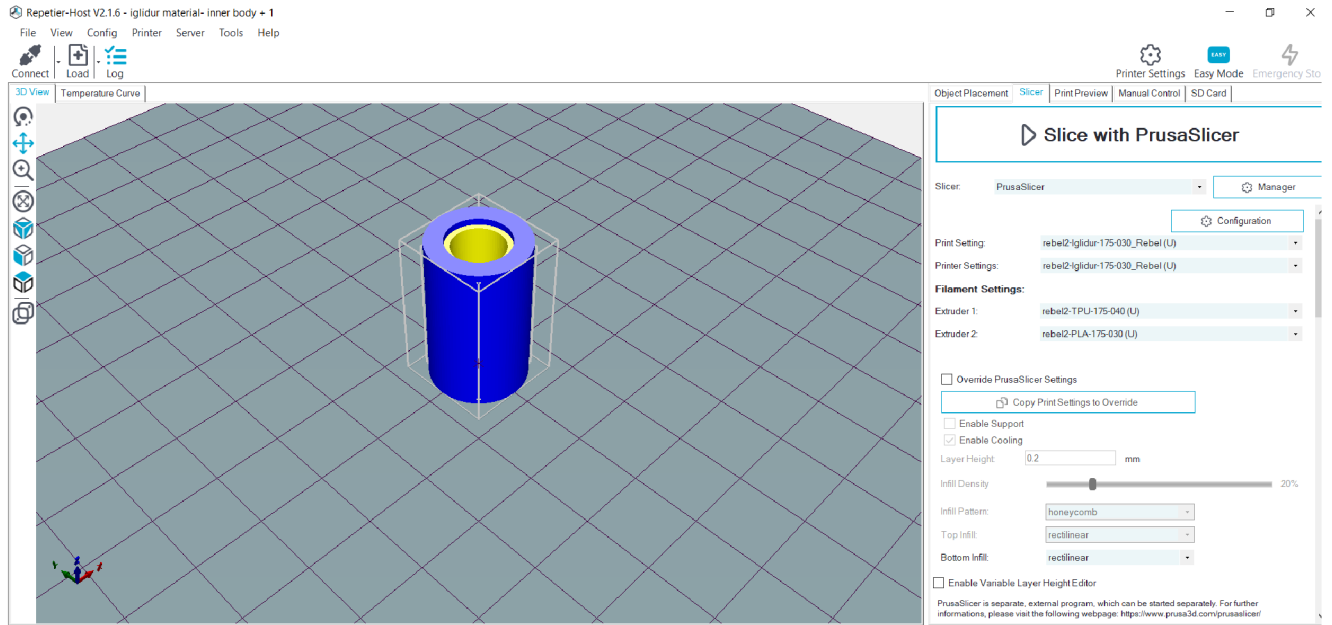

Figure 34: Slice with PursaSlicer

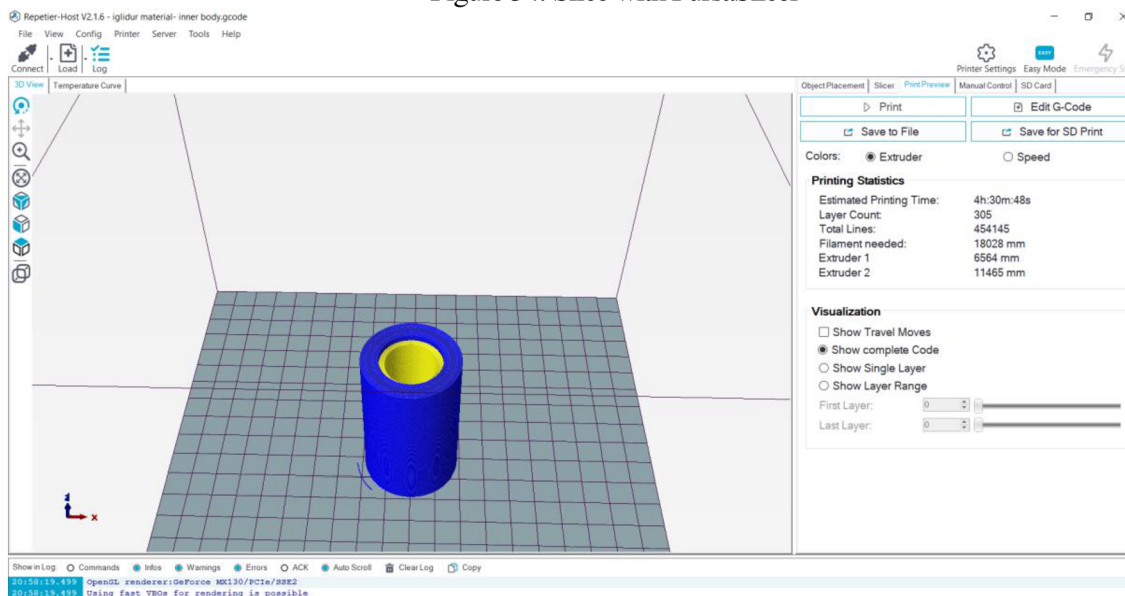

Figure 35: Printer Preview- Without Ooze Shield

The part is printed during slicing, and the sample is shown. In each extruder, details such as the number of layers, expected time, and amount of material required for printing are calculated and displayed. It is possible to see each and every layer of the print individually as shown below.

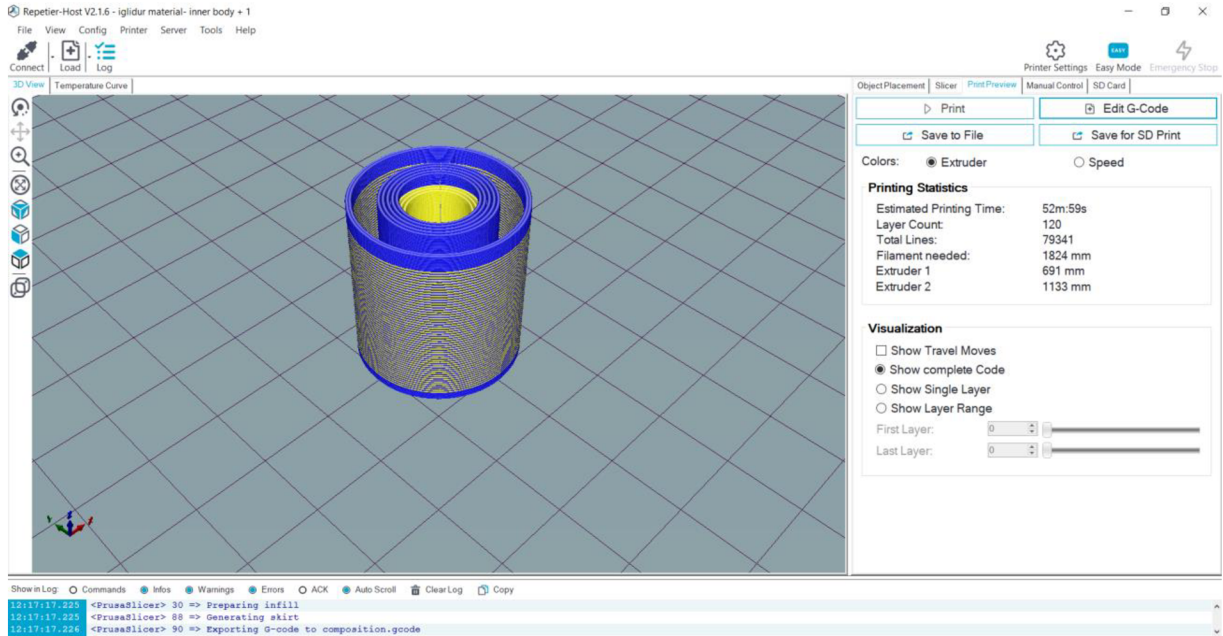

Figure 36: Printer Preview- With Ooze Shield

Fig 36 shows the print of both material 1 and 2 from corresponding extruders. The internal structure is used as honeycomb which allows for the use of low-cost, high-strength materials.

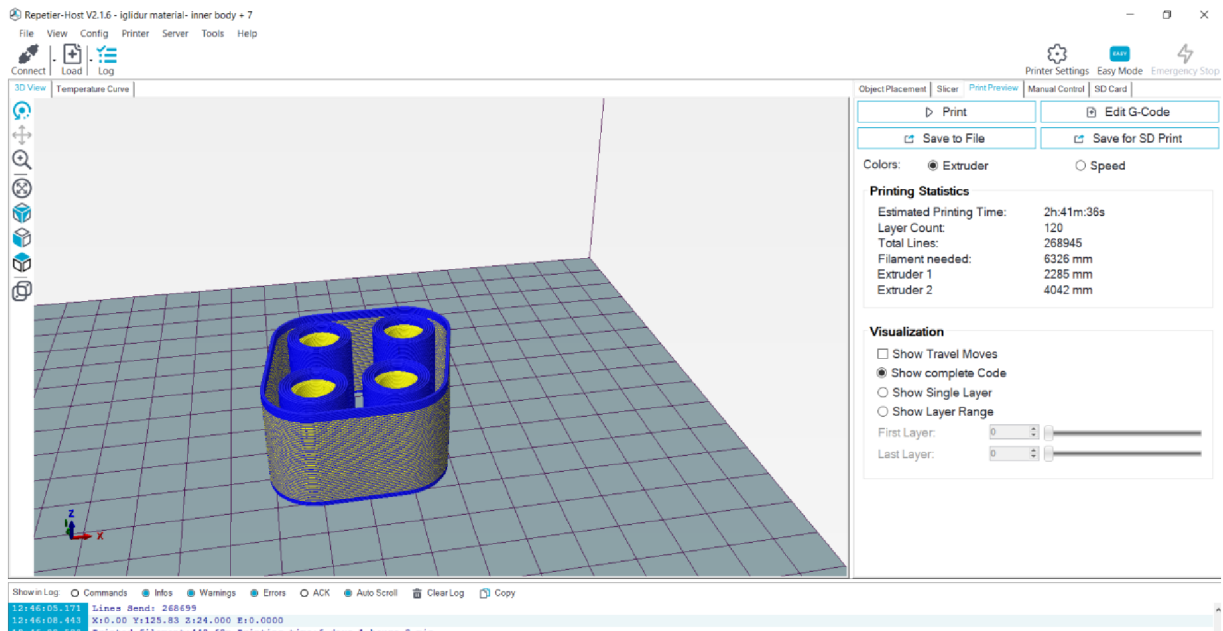

Figure 37: Printer Preview- 4 Object

10. PRINTER PRODUCTION- Hard and Flexible Material:

10.1. PursaSlicer:

PrusaSlicer is a slicer tool based on the open-source project Slic3r (previously known as Slic3r Prusa Edition or Slic3r PE). PrusaSlicer is an open-source, feature-rich, and frequently updated utility that provides everything you'll need to export the necessary print files for your Prusa 3D printer.

10.2. Object Placement:

As indicated in the figure, the object is made up of two components: an outside and an inner component. Each part is given its own nozzle and positioned in the center. The workspace indicated in the program corresponds to the printer's workspace. The parts are printed according to the software's instructions, so the two different components are centered or on the same axis.

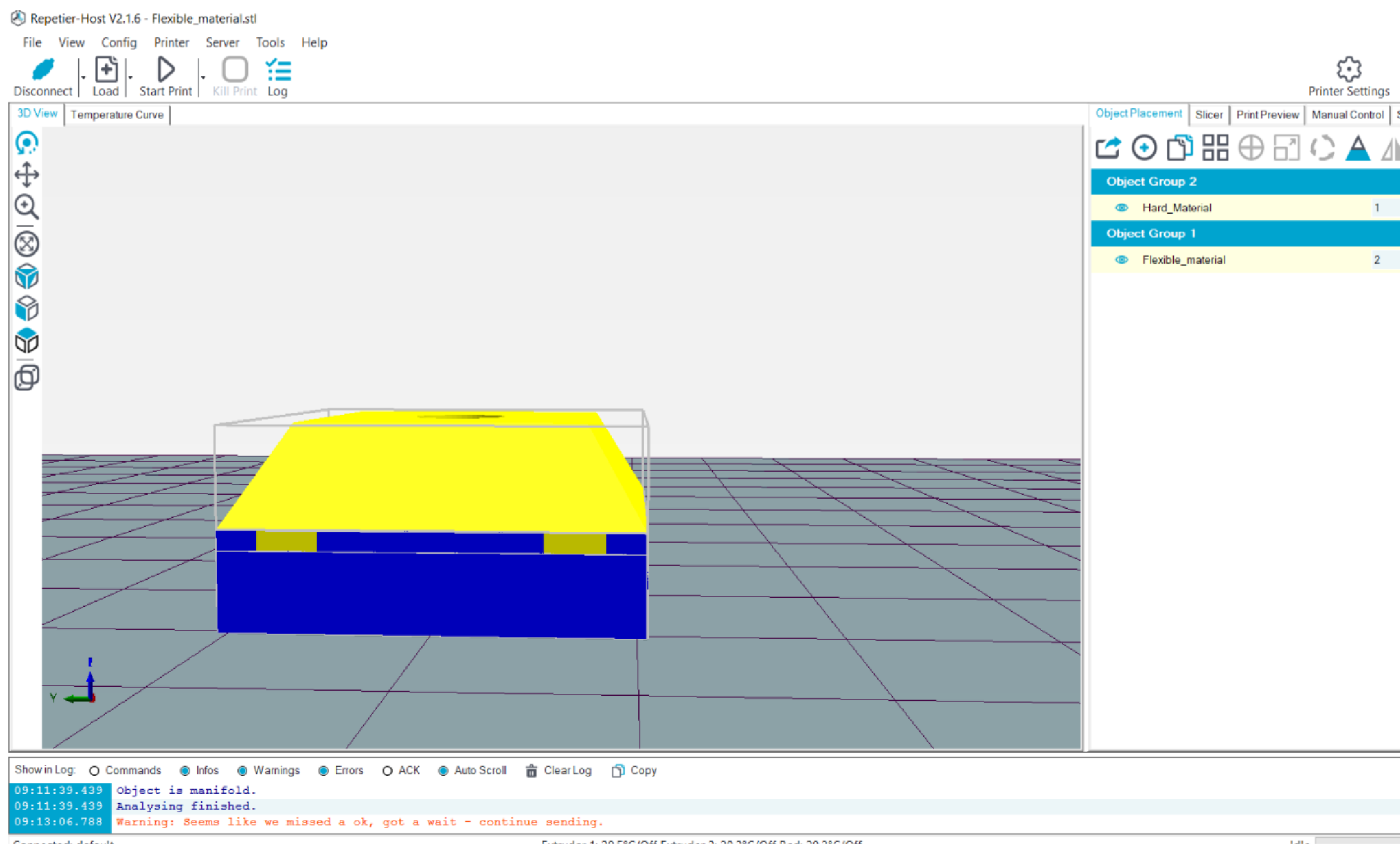

Figure 38: Object Placement-Hard and Flexible Material

10.3. Slicer:

While slicing, the part is printed and the sample is display below. In each extruder, details such as the number of layers, expected time, and amount of material required for printing are calculated and displayed. It is possible to view each and every layer of the print individually as shown below. Figure 39 shows the print sample of the layer 1, which include the print of both material 1 and 2 from corresponding extruders. The internal structure is honeycomb, which allows for the use of low-cost, high-strength materials.

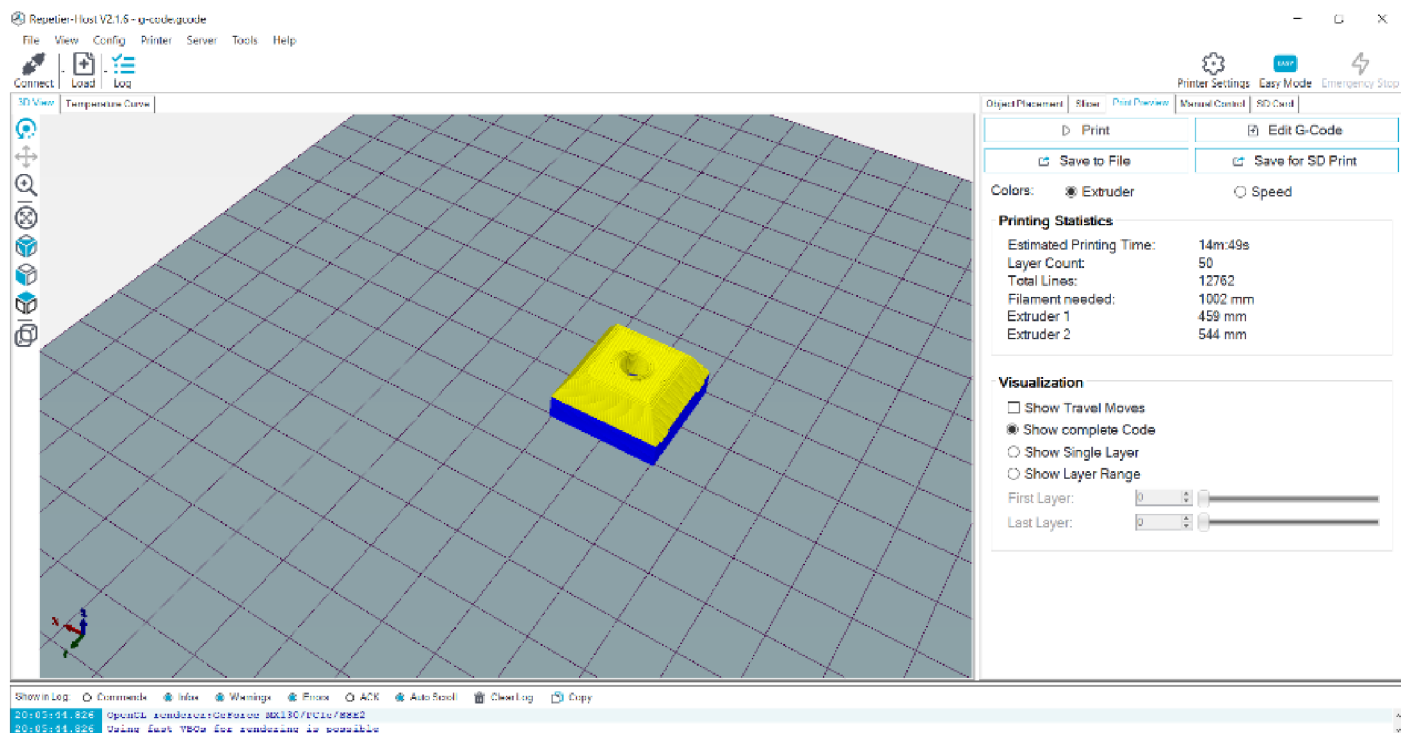

Figure 39: Print Preview- Hard and Flexible Material

Repetier Software allows to enter manual codes at certain locations to improve print quality. This aids in the addition or removal of a procedure. Manual codes can be inserted at many points throughout the process, including the start of the printing process, the completion of the program, and before or after layer changes. These manual codes can be used to cause the nozzle to stop to perform any actions like cleaning or cooling of the previous layer. Figure 39 shows the manual coding page of the Prusa Slicer printer configuration.

11. RESULT- Linear Bearing:

11.1. Linear Bearing- Trail 1:



Figure 40: Linear Bearing- Test 1

When the print head travels between two points, filament is notorious for string from the nozzle. This form strings on the prints that affect the quality of 3D printed model.



Figure 41: Linear Bearing- Test 2

In this picture, 3D printing quality is worst. Then I approached the rubber holder to improve surface finish. Each layer to take the nozzle to the corner and clean it with brush and rubber. Brush and Rubber will wipe the hanging filament.

11.2. Rebel II – Brush Support for Nozzle Cleaning:

I made a support for a brush on the right side of the Z-axis of Rebel II. Its help on three issues.

- I can add a g-code in between layers to clean the nozzle, which has a habit of gathering filament on the nozzle on extended prints.
- Before starting each print, I can do a purge on the corner, and the brush will wipe the dangling filament as it moves to start the print.
- When I change filaments, it purges until the color or substance changes, and I no longer have to manually wipe the nozzle.

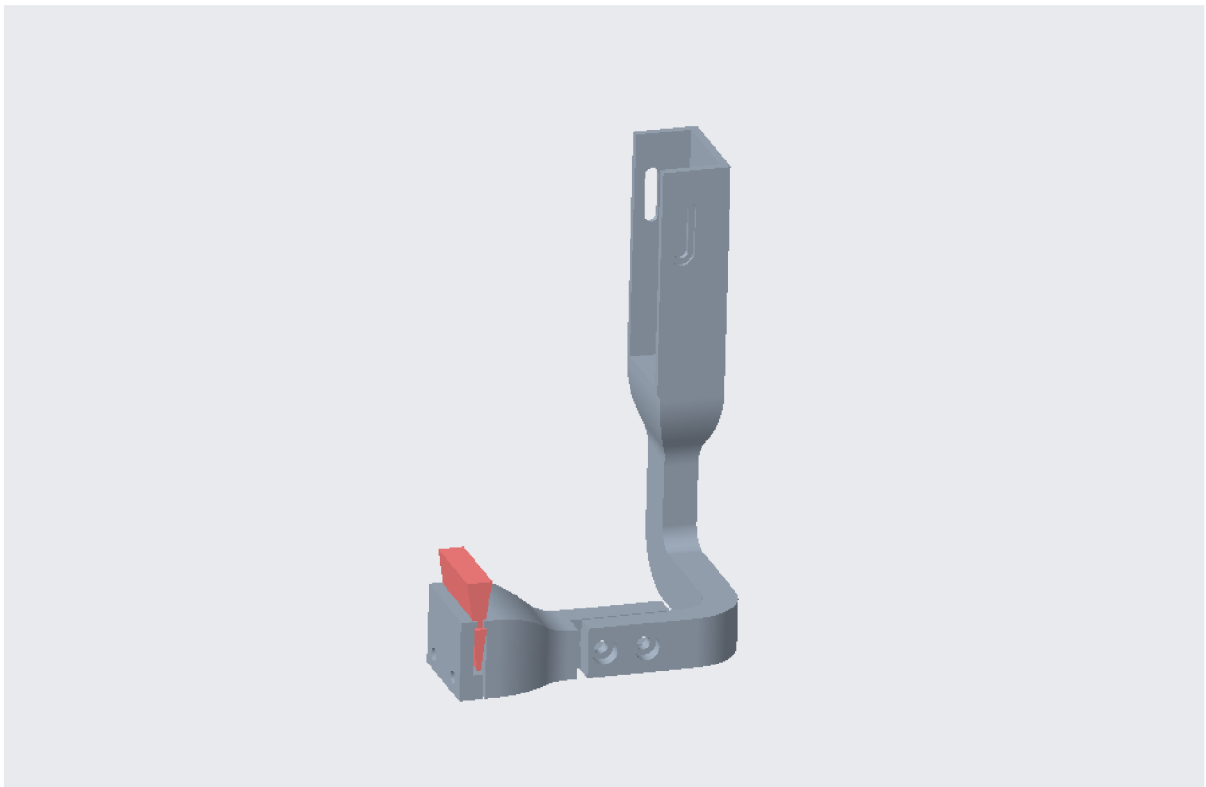

Figure 42: 3D model of Brush and Holder

How the brush holder are attached in the 3D printer. It's shown in the below fig.43.



Figure 43: Brush and Holder

I was faced some problem in our old model, so modified the old model and added silicon rubber in this model. The changes are made only the holder in the previous CAD model rest remains same. Here is our new model of holder and brush.

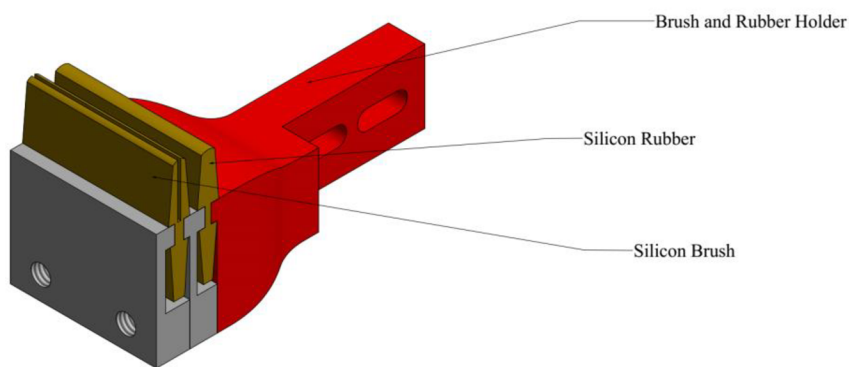

Figure 44: New Brush and Rubber Holder- 3D model

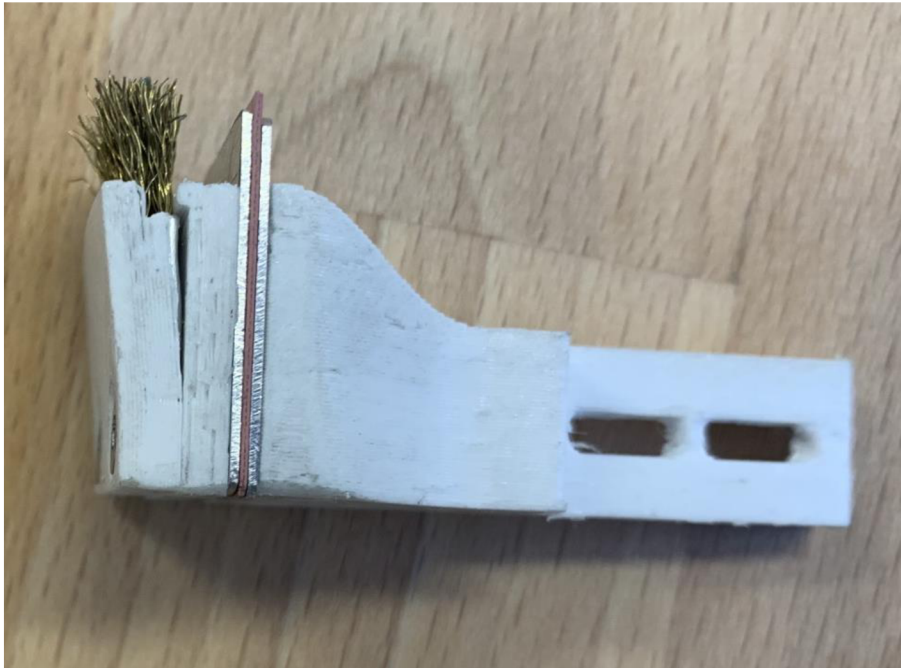

Figure 45: Brush and Rubber Holder

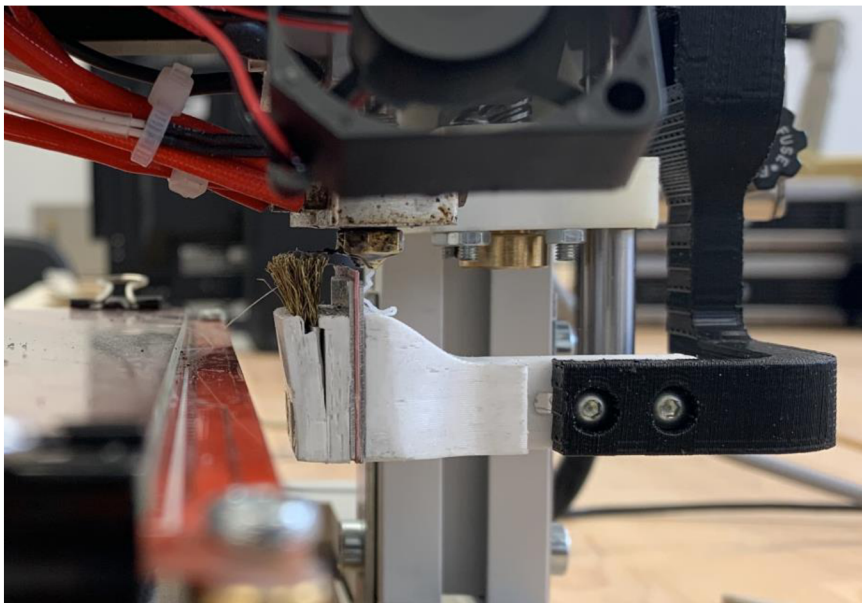

Figure 46: New brush and Rubber Holder

In this fig. 46 shows how the brush holder clean the nozzle and make the nozzle ready for next print. Here shown the gap between the rubber brush and work bench.

11.3. Linear Bearing- Trial 2:

After Installed the Brush and Rubber holder and then I make a print. I get the better result than previous test. The result are shown in Fig. 47.



Figure 47: Linear Bearing - Test 3

11.4. Ooze Shield:

At the commencement of a print job, skirts outline a print. Set one or two outlines to get things moving and to see how the final print will look in terms of space and placement. I wear a skirt with almost every print.

11.4.1. Advantages

- Assists in ensuring that the filament adheres adequately to the print bed at the start of a print.
- Displays the total amount of space required for the print.

11.4.2. Disadvantages

- A little additional printing time at the start.
- If it does not stick well at first, some strings may become stuck to the print.

11.5. Linear Bearing- Trail 3:



Figure 48: Linear Bearing – with Ooze shield

Skirt or Ooze Shield is used to protect an object. A skirt is an outline that encircles but does not touch your body part. Before beginning to print the model, the skirt is extruded on the print bed. Skirts are useful because they aid in priming the extruder and establishing a smooth filament flow.

To use a Skirt is:

- A lack of material flow,
- Bed is unleveled.
- A lack of layer adhesion.

● Loops (minimum):	<input type="checkbox"/> <input type="checkbox"/>	•	<input type="text" value="2"/>	<input type="button" value="▲"/>	<input type="button" value="▼"/>	
● Distance from object:	<input type="checkbox"/>	•	<input type="text" value="3"/>		mm	
● Skirt height:	<input type="checkbox"/>	•	<input type="text" value="1"/>	<input type="button" value="▲"/>	<input type="button" value="▼"/>	layers
● Draft shield:	<input type="checkbox"/>	•	<input type="checkbox"/>			
● Minimal filament extrusion length:	<input type="checkbox"/>	<input type="checkbox"/>	<input type="text" value="1000"/>		mm	

Figure 49: Skirt Setting



Figure 50: Linear Bearing - without Ooze Shield

What I have done to fix the surface problem are Ooze shield, reduce print speed and removing support filament. It can be accomplished a perfect shape.

12. RESULT- Hard and Flexible Material:

Based on the challenges that users have previously encountered, there are certain factors that you should keep in mind when printing with these materials.

- Thermoplastic elastomers are known to be poorly handled by the printer's extrusion.
- They absorb moisture, the filament is not stored properly.
- Thermoplastic elastomers are sensitive to rapid movements so it might buckle up when forced through the extruder.

12.1. Hard and Flexible Material- Trail 1:



Figure 51: Hard and Flexible Material- Trail 1

12.2. Hard and Flexible Material- Trail 2:



Figure 52: Hard and Flexible Material- Trail 2

The materials mentioned above are used in a variety of applications. In general, combined both hard filaments and flexible filament are very difficult and poor quality. Here the quality of parts or functional prototypes are produce absolutely remarkable and extraordinary.

13. DIMENSION COMPARISON OF 3D PRINTED MODEL:

13.1. Linear Bearing Parameters:

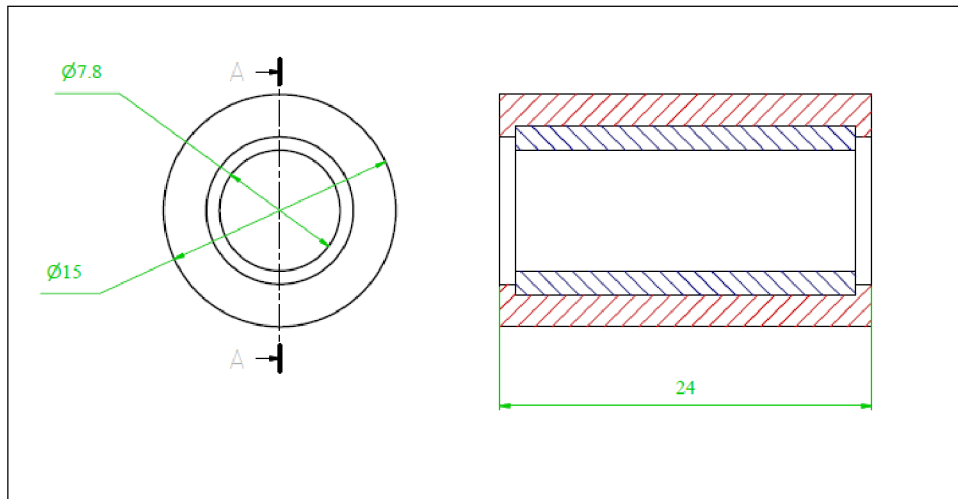

Figure 53: Linear Bearing Parameters

Parameters	Dimension
External Diameter	Ø 15 mm
Internal Diameter	Ø 7.8 mm
Length of the Model	24 mm



Figure 54: Measurement using vernier caliper

Comparing between the both given and measured dimension are approximately same by using vernier caliper. The linear bearing are machined with respective dimension and then it's attached with REBEL II 3D printer.

13.2. Hard and Flexible Material Parameters:

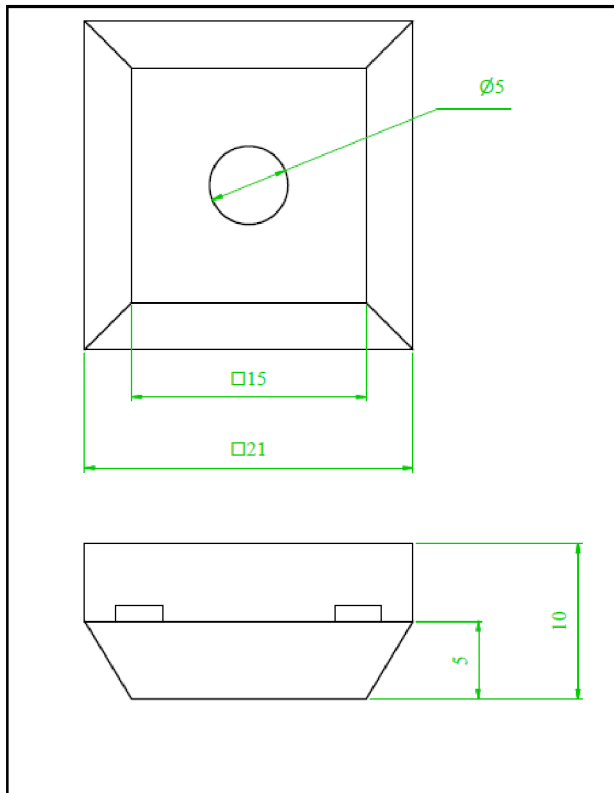

Figure 55: Parameters



Figure 56: Measurement using vernier caliper

Comparing between the both given and measured dimension are approximately same. By using the flexible material the measured dimension are normal.

14. CONCLUSION:

Rebel II is a 3D printer that can print filament-based materials. It is designed generally with a single nozzle. Extra nozzle is added in order to print with multiple materials. Certain issues, Over- Extrusion, have an effect on print quality. This issue reduced quality is focused here, the main aim of this thesis is to improve the quality of the print. Linear bearing and two different material model (Hard and Flexible material) are designed and printed to check the quality of the print, it was designed as two parts to be able to print by multiple nozzles the defects in the print are identified. So far, the filament switch appears to be working perfectly. Of course, I have yet to complete a print with it, but what is now printing seems promising.

In this paper, was described about the convenient approach to assessing the quality of 3D printed objects. The small strings of filament are left on a printed model was found to be neither extrusion temperature, nor the type of polymer substantially impact the quality. By using the temperature changes and brush holder approaches, it was showed that there were some development in the 3D printed object. The purpose of Ooze shield test done again and again to show the gradual improvement of the quality of 3D printed objects by eliminating the structural defect. Of course, I was faced some challenges while printing the PLA and Thermoplastic elastomer material. The main difficulties which I was faced in extrusion, filament wrapped around the arm and weak infill. It will also ruin a print by making it look less perfect, but these were commonly occurs with flexible filaments. I've done by reduce the printed speed and also set the nozzle at maximum temperature until print seems to be good.

All in all REBEL II seems to be a very fun and proper working option for multi-color or even multi material printing. I had a lot of experiment with this, for sure, I've done more updates on REBEL II 3D printer using Multi Material prints. REBEL II 3D printing is incredibly useful for prototyping, end-use production, and time-saving purposes. There are possible to create many models that require multiple colors, a combination of materials or support for complex geometries, then a printer that supports multi-material printing will be the best investment in the long run.

15. REFERENCE:

- [1] *3d printing process concept Royalty Free Vector Image* [online]. [vid. 2021-04-04]. Dostupné z: <https://www.vectorstock.com/royalty-free-vector/3d-printing-process-concept-vector-18095272>
- [2] *2. Generic AM process, showing the eight steps from CAD design to the... | Download Scientific Diagram* [online]. [vid. 2021-04-04]. Dostupné z: https://www.researchgate.net/figure/Generic-AM-process-showing-the-eight-steps-from-CAD-design-to-the-finished-product_fig2_331071064
- [3] ABDULHAMEED, Osama, Abdulrahman AL-AHMARI, Wadea AMEEN a Syed Hammad MIAN. Additive manufacturing: Challenges, trends, and applications Manufacturing processes [online]. 2019, **11**(2), 1–27 [vid. 2021-05-07]. Dostupné z: doi:10.1177/1687814018822880
- [4] *Additive Manufacturing/3D Printing: Introduction and Applications* [online]. [vid. 2021-04-04]. Dostupné z: <https://omnexus.specialchem.com/selection-guide/3d-printing-and-additive-manufacturing-polymers-and-processes>
- [5] *Introduction to FDM 3D printing | 3D Hubs* [online]. [vid. 2021-04-05]. Dostupné z: <https://www.3dhubs.com/knowledge-base/introduction-fdm-3d-printing/>
- [6] *A schematic illustration of the FDM 3D printing technology | Download Scientific Diagram* [online]. [vid. 2021-04-04]. Dostupné z: https://www.researchgate.net/figure/A-schematic-illustration-of-the-FDM-3D-printing-technology_fig1_333719097
- [7] *Fused Deposition Modeling | FDM 3D Printer Technology* [online]. [vid. 2021-03-30]. Dostupné z: <https://www.creativitybuzz.org/fused-deposition-modeling/>
- [8] *Why the Core3D printer uses CoreXY – Core3D Custom Printers* [online]. [vid. 2021-03-30]. Dostupné z: <https://core3d.tech/2017/06/10/why-core3d-printer-uses-corexy/>
- [9] *Hands On With The Prusa MMU2S, Part 1 « Fabbaloo* [online]. [vid. 2021-05-17]. Dostupné z: <https://www.fabbaloo.com/blog/2020/1/21/hands-on-with-the-prusa-mmu2s-part-1>
- [10] *10 Of The Best Dual Extruder 3D Printers 2021 | 3DSourced* [online]. [vid. 2021-04-05]. Dostupné z: <https://www.3dsourced.com/3d-printers/dual-extruder-3d-printer/>
- [11] *Ultimate Materials Guide - Tips for 3D Printing with PLA* [online]. [vid. 2021-04-06]. Dostupné z: <https://www.simplify3d.com/support/materials-guide/pla/>
- [12] *iglidur® I150-PF | 750g | igus®* [online]. [vid. 2021-04-05]. Dostupné z: <https://www.crea3d.com/en/igus/655-775-iglidur-i150-pf-750g-igus.html>
- [13] *TPE 88 RubberJet Flex - translucent (1.75 mm; 0.5 kg) | Filament PM* [online]. [vid. 2021-05-07]. Dostupné z: <https://www.filament-pm.cz/tpe-88-rubberjet-flex-translucent-1-75-mm-0-5-kg/p91>



- [14] *Installation and configuration - Repetier-Host documentation* [online]. [vid. 2021-04-04]. Dostupné z: <https://www.repetier.com/documentation/repetier-host/rh-installation-and-configuration/>
- [15] *Fill your print bed - Repetier-Host Documentation* [online]. [vid. 2021-04-05]. Dostupné z: <https://www.repetier.com/documentation/repetier-host/object-placement/>
- [16] *Repetier-Host Documentation - Repetier Software* [online]. [vid. 2021-04-06]. Dostupné z: <https://www.repetier.com/documentation/repetier-host/rhmanual-control/>
- [17] *PrusaSlicer - Prusa3D - 3D Printers from Josef Průša* [online]. [vid. 2021-05-07]. Dostupné z: <https://www.prusa3d.com/prusaslicer/>
- [18] *3D Printing Terminology* [online]. [vid. 2021-05-03]. Dostupné z: <http://www.abbymath.com/3DPrinting/Terminology.htm>