



BRNO UNIVERSITY OF TECHNOLOGY

VYSOKÉ UČENÍ TECHNICKÉ V BRNĚ

FACULTY OF ELECTRICAL ENGINEERING AND COMMUNICATION

FAKULTA ELEKTROTECHNIKY A KOMUNIKAČNÍCH TECHNOLOGIÍ

DEPARTMENT OF ELECTRICAL POWER ENGINEERING

ÚSTAV ELEKTROENERGETIKY

APPLICATION OF SENSORS AND DIGITALIZATION BASED ON IEC 61850 IN MEDIUM VOLTAGE NETWORKS AND SWITCHGEARS

APLIKACE SENZORŮ A DIGITALIZACE PODLE IEC 61850 V SÍTÍCH A ROZVODNÁCH
VYSOKÉHO NAPĚTÍ

DOCTORAL THESIS

DIZERTAČNÍ PRÁCE

AUTHOR

AUTOR PRÁCE

Ing. Martin Štefanka

SUPERVISOR

VEDOUCÍ PRÁCE

doc. Ing. Petr Toman, Ph.D.

BRNO 2016

Bibliographic citation:

ŠTEFANKA, M. *Application of sensors and digitalization based on IEC 61850 in medium voltage networks and switchgears*. Brno: Brno University of technology, Faculty of electrical engineering and communication, 2016. 149p. Supervisor of doctoral thesis: doc.Ing Petr Toman, Ph.D.

This is to certify that to the best of my knowledge, the content of this thesis including appendixes is my own work. This thesis has not been submitted for any degree or other purposes. I certify that the intellectual content of this thesis is the product of my own work and that all the assistance received in preparing this thesis and sources have been acknowledged.

Martin Stefanka

Acknowledgments:

I wish to express my gratitude to my supervisor doc.Ing. Peter Toman, Ph.D. for his guidance during my doctoral study. Further I wish to acknowledge the excellent support I received from laboratory technicians of ABB s.r.o. Brno Ing. Vlastimil Křápek and Ing. Ján Švindrych for their great work on all testing of sensors defined by me and which are subject of this thesis. I would like to also thank to Ing. Martin Čelko and Ing. Václav Prokop for their engagement during finalization of UniGear Digital concept. I want also thank to doc.Ing. Miroslav Mejzlík, CSc. for his valuable comments and reviews. Finally, I would to thank to my manager Dr. Gerhard Salge for his professional support during entire doctoral study.

Brno, January 2016

Ing. Martin Štefanka

ABSTRACT

Medium voltage air insulated switchgear is an important element in energy distribution chain both in industry and utility segments. Switchgear main functions are protection of operational personnel, disconnecting, insulating, switching of energy, measuring of currents and voltages, protection and control of loads and communication of data to control systems.

There have been technology evolution in every above mentioned functions during last 40 years. Switchgears today are reliable arc proof constructions with the footprint optimized close to physics limits of dielectric, electromagnetic and thermodynamic fields. Vacuum based technology circuit breakers provides durable and reliable switching functionality and we have seen several technology changes in protection, control and communication. From electromechanical to transistor based relays thru single purpose microprocessor based relays up to today's multifunctional high performing microprocessor based intelligent electronic devices. Only the area of measurements of currents and voltages have remained in last 40 years unchanged from the basic technology stand point. Still, inductive principal based current and voltage transformers are dominating measuring technology today. Some attempts were made to change measuring technology as such, but no success has been achieved.

This thesis is focused to offer a new view on alternative measuring technologies to be used in medium voltage air insulated switchgears and networks both for currents and voltage measurements. Thesis explains why Rogowski coil, resistive and voltage divider are the right choice to be used in medium voltage switchgears. It analyzes in details measurement accuracy constrains of them. Further, thesis explains that deployment of the new measuring technology must be done from the system approach stand point. Sensors connected to intelligent electronic device with communication capability based on IEC 61850 and high speed communication Ethernet bus create a system that simplifies and uniforms switchgear design and allows decoupling of measuring devices engineering aspects from short circuit selectivity study. Thesis also shows example, how this new system can bring changes and simplification to protection and control domain.

The result of several years of efforts to define new measuring and digitalization approach in medium voltage switchgear under my leadership are documented in this thesis. This effort lead also to a release of the new product - UniGear Digital concepts from ABB. Final parts of my thesis demonstrates practical deployment of all results documented in this thesis in real application.

KEY WORDS: Rogowski coil; resistive divider; capacitive divider; measurement accuracy; medium voltage; switchgear; IEC 61850; process bus; communication; residual current

ABSTRAKT

Vzduchem izolované vysokonapěťové rozváděče jsou nedílnou součástí energetického distribučního řetězce a to jak v průmyslovém, tak ve veřejném sektoru. Hlavní funkcí rozváděče je ochrana pracovního personálu, rozpojování/odpojování a spínání, izolování, měření proudů a napětí, chránění a ovládání zatížení a komunikace dat do řídicích systémů.

V každé z výše zmíněných funkcí probíhal technologický vývoj v průběhu posledních 40 let. Dnešní rozváděče jsou spolehlivé a elektrickému oblouku odolné zařízení, zoptimalizované téměř k fyzikálním limitům dielektrických, elektromagnetických a termodynamických polí. Vakuové vypínače zajišťují stálou a spolehlivou vypínací funkci. Taktéž v oblasti chránění, řízení a komunikace došlo k mnoha technologickým proměnám. Od elektromechanických relé přes zařízení založená na tranzistorech, později na jednoúčelových mikroprocesorech, až po dnešní multifunkční vysoce výkonná mikroprocesorová inteligentní elektronická zařízení. Pouze oblast měření proudů a napětí setrvala z technologického hlediska posledních 40 let beze změny. K dominujícím měřicím technologiím dneška stále ještě patří indukčně založené transformátory proudu a napětí. Byly sice provedeny některé pokusy k obměně technologie měření jako takové, nicméně bez dosažení úspěchu.

Tato dizertační práce je zaměřena na poskytnutí nového náhledu na alternativní technologii měření v elektrických sítích a ve vzduchem izolovaných vysokonapěťových rozváděčích, kterou lze využít jak pro měření proudu, tak i napětí. Tato práce vysvětluje, proč Rogowského cívky, odporové a kapacitní děliče jsou tou správnou volbou a měly by být použity ve vysokonapěťových rozváděčích a podrobně analyzuje přesnost měření a jejich příslušné meze. Dále tato práce popisuje, že pro nasazování nových měřicích technologií musí být postupováno systematicky. Senzory připojené k inteligentním elektronickým přístrojům a schopností komunikace založené na IEC 61850 spolu s vysokorychlostní komunikační sběrnici Ethernetu vytvoří systém, který zjednoduší a sjednotí konstrukci rozváděčů a umožní oddělit aspekty projektování měření od studie zkratových selektivit. V práci je také uveden příklad, jak tento nový systém může přinést změny a zjednodušení do oblastí projektování a řízení.

V této práci jsou popsány výsledky několikaletého úsilí při stanovení nových měřicích a digitalizovaných přístupů ve vysokonapěťových rozváděčích pod autorovým vedením. Toto úsilí také vedlo k uvedení nového produktu – UniGear Digital - konceptu od ABB. Závěrečná část práce demonstuje praktické nasazení všech výsledků v této práci při skutečných aplikacích.

KLÍČOVÁ SLOVA: Rogowského cívka; odporový dělič; kapacitní dělič; přesnost měření; vysoké napětí; rozváděč; IEC 61850; procesní sběrnice; komunikace; reziduální proud

TABLE OF CONTENTS

- ABSTRACT 4
- TABLE OF CONTENTS 6
- LIST OF ABBREVIATIONS..... 9
- 1 INTRODUCTION.....10
- 2 DESCRIPTION OF THE PRIMARY AIR INSULATED SWITCHGER12
- 3 OVERVIEW OF THE PRIMARY AIR INSULATED SWITCHGEAR STATE OF THE ART ...14
 - 3.1 Primary part..... 14
 - 3.2 Measuring and sensing part..... 15
 - 3.2.1 Comparison of available current measurement principles 15
 - 3.2.2 Rogowski coil principle and its measurement accuracy performance 16
 - 3.2.3 Comparison of available voltage measurement principles..... 18
 - 3.2.4 Resistive and capacitive dividers principles, measurement accuracy performance 19
 - 3.3 Control part.....21
 - 3.3.1 Measurements distribution in substation22
 - 3.3.2 Basic Introduction of IEC 61850 [6].....22
- 4 TARGETS OF THE DOCTORAL THESIS.....26
- 5 INFLUENCE OF EXTERNAL FACTORS ON SENSORS ACCURACY27
 - 5.1 General introduction and assumptions.....27
 - 5.2 Sensors amplitude and phase measuring accuracy as function of temperature29
 - 5.2.1 General arrangements and rational of the measurement29
 - 5.2.2 Parameters of the measurement.....29
 - 5.2.3 Results and conclusions – Rogowski coil31
 - 5.2.4 Results and conclusions – Capacitive voltage divider32
 - 5.2.5 Results and conclusions – Resistive voltage divider.....33
 - 5.3 Sensors amplitude and phase measurement accuracy as function of the cable length between sensor and IED - Basic accuracy test34
 - 5.3.1 General arrangements and rational of the measurement34
 - 5.3.2 Parameters of the measurement.....34
 - 5.3.3 Results and conclusions – Rogowski coil35
 - 5.3.4 Results and conclusions – Resistive voltage divider.....36
 - 5.4 Sensors amplitude and phase measurement accuracy as function of frequency – Frequency response.....36

APPLICATION OF SENSORS AND DIGITALIZATION BASED ON IEC 61850 IN MEDIUM VOLTAGE NETWORKS AND SWITCHGEARS

- 5.4.1 General arrangements and rational of the measurement 36
- 5.4.2 Parameters of the measurement..... 37
- 5.4.3 Results and conclusions – Rogowski coil 37
- 5.4.4 Results and conclusions – Resistive voltage divider..... 39
- 5.4.5 Results and conclusions – Capacitive voltage divider 41
- 5.5 Overall conclusions on applications of Rogowski coil, resistive and capacitive divider in MV networks and switchgears 42
- 6 CALCULATION OF RESIDUAL CURRENT, APPLICATION OF ROGOWSKI COIL 45**
 - 6.1 General arrangements and rational of the measurement 45
 - 6.2 Parameters of the laboratory tests 48
 - 6.3 Results and conclusions from the laboratory tests..... 49
 - 6.4 Results and conclusions from testing on primary network model 51
 - 6.4.1 Stability test on inrush current in the network caused by the power transformer 51
 - 6.4.2 Earth fault in system with isolated neutral 52
 - 6.4.3 Earth fault in system with high impedance neutral 53
 - 6.5 Overall conclusions of the Rogowski coil application for earth fault protection 54
- 7 NEW ARCHITECTURE OF MV AIR INSULATED SWITCHGEAR AND SUBSTATION 57**
 - 7.1 Definition of the gap 57
 - 7.2 Architecture of the MV air insulated switchgear with sensors and process bus. 58
 - 7.2.1 First step – definition of the standard feeders 59
 - 7.2.2 Second step - Overall example of the single line diagram and communication bus..... 63
 - 7.2.3 Third step - Calculation of communication bandwidth..... 65
 - 7.2.4 Fourth step - Selection of communication architecture and redundancy principle 67
 - 7.2.5 Reliability study of PRP and HSR redundant communication architectures 69
 - 7.3 Overall conclusions – Architecture of MV switchgear with sensors and process bus 73
- 8 EXAMPLE OF THE NEW SUBSTATION ARCHITESTURE APPLICATION 75**
 - 8.1 Verification of hypothesis – digital switchgear..... 75
 - 8.2 Example of the product application 76
 - 8.2.1 Use of the typical feeders with sensors and digital bus 76
 - 8.2.2 Selection of communication architecture 78
 - 8.2.3 Interlocking, blocking, control and measurement schemes through digital bus..... 78
- 9 CONSLUSIONS AND CLOSINGS 81**
- LIST OF PICTURES 87
- LIST OF THE TABLES..... 89
- REFERENCES 90
- LIST OF PUBLICATIONS, ARTICLES and PATENTS 93

APPENDICES	94
Appendix 1 Specification of indoor combined sensor KEVCD 24 AE3.....	94
Appendix 2 Specification of indoor combined sensor KEVA 24 C21	97
Appendix 3 Specification of indoor combined sensor KEVCY 24 RE1	99
Appendix 4 Specification of indoor combined sensor KEVCR 17.5 CA1	101
Appendix 5 Sensors amplitude and phase measurement accuracy as function of temp.	103
Appendix 6 Sensors amplitude and phase measurement accuracy as function of temp.	107
Appendix 7 Rog. coil and resistive voltage divider basic acc. tests and freq. response	110
Appendix 8 Capacitive voltage divider frequency response.....	122
Appendix 9 Static measurements of I_{oap} – apparent residual current	127
Appendix 10 Detailed drawings – 7.2kV substation Fortischem a.s. Novaky	135
CURICULUM VITAE	149

LIST OF ABBREVIATIONS

I_r – Rated current [A]

I_k'' – Rated short circuit current [A]

I_{L1}, I_{L2}, I_{L3} – Phase to ground currents [A]

I_0 – Residual current [A]

I_p – Perspective current [A]

$I_{0(ap)}$ – Residual apparent current [A]

U_p – Primary voltage [V]

U_s – Secondary voltage [V]

M – Mutual inductance [H]

MV – Medium Voltage

IEC – International Electrotechnical Commission

HV – High Voltage

IED – Intelligent Electronic Device

IT – Instrument transformer

RC – Rogowski Coil

SAS – Substation Automation System

$FOCS$ – Fiber optic current sensing

$FOVS$ – Fiber optic voltage sensing

HMI – Human machine interface

AIS – Air insulated switchgear

HSR – High-availability seamless redundancy

PRP – Parallel redundancy protocol

$SCADA$ – Supervisory control and data acquisition

SMV – Sampled measured values

$RSTP$ – Redundant spanning tree protocol

DR – Disturbance record

1 INTRODUCTION

Medium voltage (MV) switchgears are important part of the energy distribution chain in an alternating current (AC) systems from the power generation through the transmission and final distribution to the consumers of the energy. The frame of the specification, terms and definitions, ratings, design and construction, type testing and production routine testing are described for the European region in following standards:

- IEC 62271-1 High-voltage switchgear and controlgear – Common specification [1]
- IEC 62271-200 AC metal-enclosed switchgear and controlgear for rated voltages above 1 kV and up to and including 52 kV [2]
- IEC 62271-300 Gas-Insulated Metal-Enclosed Switchgear for Rated Voltages Above 52 kV [3]

IEC standards are widely accepted around the world, however some of the large countries such as United States, China or Russia have different standards.

Section 3.5 of the IEC 62271-1 [1] specifies all possible parts of switchgear and controlgear. Combination of the parts together, creates switchgear system with following functionalities in MV networks:

- Distribution of the energy from upper level transmission system down to energy consumption point
- Switching of the energy
- Measurements for protection, indication and billing purposes
- Protection of loads and equipment against faults
- Control, blocking and interlocking depending on needs and approach of network operation
- Communication of data to SCADA or DCS systems
- Protection of the operational staff in substation

Various type of the switchgear designs that meets criteria of the IEC standard can be found on the market, designed and manufactured by many producers. IEC standard clearly differentiates air insulated technology [2] from the gas insulated technology [3]. This thesis is primarily focused on air insulated switchgear technology, however results can be extended also to gas insulated technology, as well. Example can be found in [17].

Switchgear design varies depending on position in distribution system. Complexity of the switchgear design is given by the level of the energy that must be reliably distributed by the switchgear and complexity of the protection and control schemes. In general, the higher the electrical parameters of the switchgear are, the higher the protection and control complexity is required. IEC standard does not specify such differentiations, however manufactures and industrial segment commonly specify following two type of the switchgears.

1. Primary switchgears - usually above $I_r = 630$ A (rated current) and $I_k'' = 20$ kA (rated short-circuit current), close to HV/MV substation where level of protection and control is high
2. Secondary switchgears - usually up to $I_r = 630$ A and $I_k'' = 20$ kA, close to end MV/LV transformation of energy distribution chain where level of protection and control is low

More details and references can be found in manufactures handbook like ABB [8], Eaton [9], and Schneider Electric [10].

This thesis is focused to primary switchgears only, results and conclusions are unlike to be extended to secondary switchgears due to the lower requirements and complexity of protection, control and communication schemes used in this segment.

2 DESCRIPTION OF THE PRIMARY AIR INSULATED SWITCHGER

Typical architecture of primary air insulated switchgears (AIS) is organized to four basic compartments:

- Basic structure
- Circuit breaker compartment
- Cable compartment
- Low voltage compartment

As shown in Fig.2-1, Fig.2-2 and Fig.2-3.

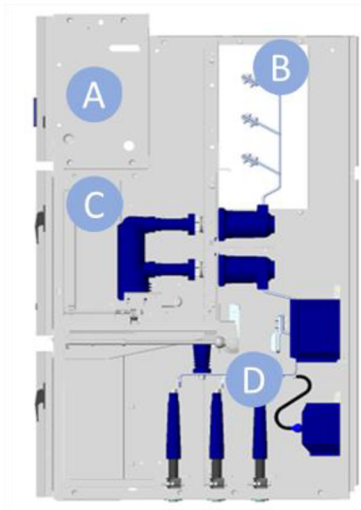

Fig. 2-1 : Cross section view ABB UniGear ZS1 [8]

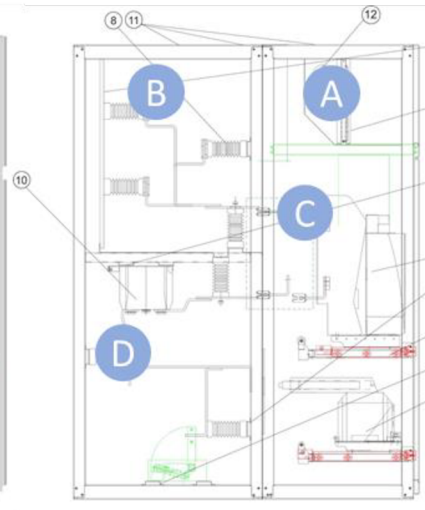

Fig. 2-2 : Cross section view Eaton 7.2kV Switchgear [9]

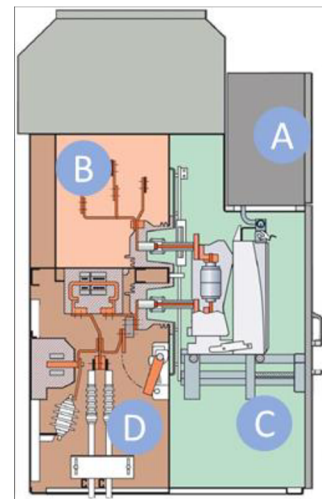

Fig. 2-3 : Cross section view Siemens NXAir [10]

1. Basic structure (marked as section B in Fig.2-1, 2-2 and 2-3) represents metal sheets that gives shape, dimensions, stiffness and robustness of the switchgear and it includes also copper parts. Copper parts carry energy and connects all compartments and apparatuses of the switchgear together. Structure as such, provides metal based segregations between compartments defined according to IEC 62271-200 different accessibility and together with arc proof door also arc withstand ability.

2. Circuit breaker compartment (marked as section C in Fig. Fig.2-1, 2-2 and 2-3) includes MV switching apparatus. Circuit breaker compartment can be equipped by various types of switching apparatuses such as load break switches, contactors, circuit breakers etc. Reliable and safe opening and closing of steady state as well as fault currents and voltages is the elementary function of the switching apparatus in the switchgear. Majority of the MV primary air insulated panels are equipped with circuit breakers. Vacuum interrupting technology in medium voltage is dominant today.
3. Cable compartment (marked as section D in Fig.2-1, 2-2 and 2-3) beside cable terminations includes sensing devices. Sensing devices primary purpose is to measure phase currents, phase voltages, residual current and residual voltage. Dominant technology for measurement is instrument transformer (IT) base on well-known inductive principal for both current and voltage measurement.
4. Low voltage compartment (marked as section A in Fig.2-1, 2-2 and 2-3) includes all auxiliary devices such as IED (Intelligent Electronic Device), meters, communication equipment, control and indication equipment, terminals and wires. All devices in low voltage compartment connected through wires and communication represent intelligent part of the switchgear, by means of management of the required protection, control, interlocking, blocking and switchgear data communication functionalities. Communication of the data from the switchgear can be managed by the large variety of the principles and communication protocols. Data communication is very important element of this thesis. The best communication standard and platform today is IEC 61850.

3 OVERVIEW OF THE PRIMARY AIR INSULATED SWITCHGEAR STATE OF THE ART

Development in the area of insulation materials, switching technology, power industrial electronic and information technologies over the last 20 years brought number of technology changes to MV switchgears and thus to MV networks.

3.1 Primary part

In depth study of electric field and possibility to model distribution of electric field helped to reduce size of AIS close to its physical limits. It looks that phase distance of 150 mm in enclosure width of 500 mm is the limit for rated voltage 17,5 kV, and phase distance of 210 mm in enclosure width of 800 mm is the limit for rated voltage 24 kV. Unless new physical laws will be found, it is extremely difficult to shrink footprint size of AIS technology further. Minimizing of dimensions, and phase distances creates risk of partial discharge increase which has significant influence on aging of insulation materials. New trends and developments are mainly towards to researching of the new materials, manufacturing and assembly methods with the target to make manufacturing and assembly more efficient.

As mentioned in chapter 2 vacuum interrupting technology in medium voltage is absolutely dominant today. Maximum switching limits reaches fault currents up to 63 kA symmetrical continuous short circuit and 164 kA dynamic peak of the fault current. A new basic technology in switching technology that could replace vacuum interrupter is not expected to come in near or mid-term future. Semiconductors (diodes) with combination of fast controlled switching are promising technology for special application switching such as capacitive loads. It is unlike that semiconductors can replace vacuum interrupters neither on short-term nor mid-term bases. Limit element is semiconductor itself. The limits of commercially available semiconductors what comes to reliable switching of energy reaches values of app. 500 MW (12 kV and 25 kA).

3.2 Measuring and sensing part

Looking at different components of the MV air insulated switchgear, sensing elements by means of instrument transformers are the oldest technology used. Introduction of new measuring principles of current and voltage is expected in near future as far as the MV switchgears are concerned. An alternative principles of current and voltage measurement have been tried to be introduced in MV air insulated switchgears and medium voltage networks several times without measurable success. There are several alternative principles of current measurements such as shunt resistance principle, optical sensor, Hall Effect etc. available. Considering available options for voltage measurements number of available technologies is limited. Alternatives to inductive measurement of voltage are limited to resistive/capacitive divider or optical principle of voltage measurements. The main constraints why alternative measuring principles called commonly together sensors are not widely used and all previous attempts to introduce them failed are following:

- Improper interpretation of the accuracy class of the measurement
- Interoperability of sensors signals and IEDs (Intelligent Electronics devices) among vendors
- Limitation of signal cable length between sensor and IED
- System aspects of current and voltage signal/data sharing in the substation
- Missing explanations of current and voltage measurements by sensors towards to protection algorithms and protection philosophy in medium voltage as such

3.2.1 Comparison of available current measurement principles

Following well known principles can be considered to be used in MV switchgears and networks.

- Shunt resistance base on principle of Ohm's Law
- Hall Effect sensors based on principle of closed loop Hall Effect
- Current measuring technology base on principle of Ampere's theorem
- Rogowski coil
- Magneto resistivity principle
- Fiber optic current sensing (FOCS) base on Faraday effect [15]
- Current transformer based on inductive principle

Selection criteria whether the principle of current measurement can be suitable in MV networks is defined by two main aspects, accuracy class and costs. Usual accuracy class limit in MV networks is 1%, however 0,5% or even 0,2% for tariff metering purpose is sometimes needed. Fig. 3-1 shows relationships between these two criteria. Similar comparison can be found in [18].

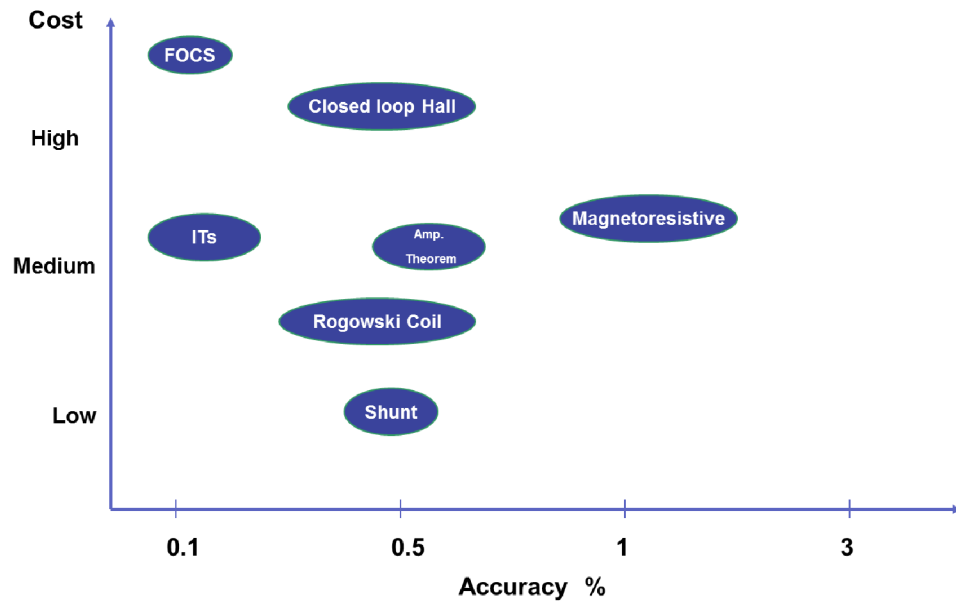
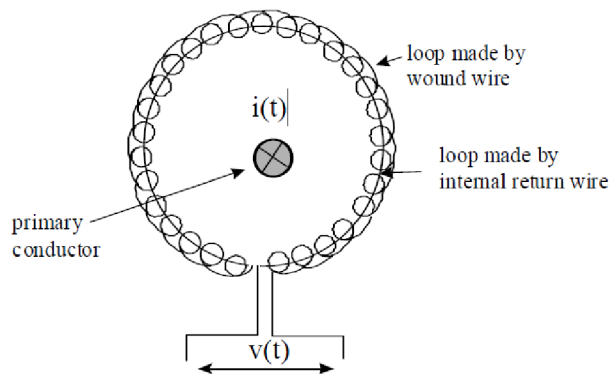

Fig. 3-1 : Relations between accuracy and costs of available current sensing tech.

From all available principles considering balance of achievable accuracy and costs, it is obvious that instrument transformer, Rogowski coil and shunt resistance are good candidates to be used in MV networks. The other principles are either too expensive or accuracy does not meet limits required by MV. Shunt resistance major issue when using in MV is to guarantee reliable and sufficient galvanic insulation, therefore application of this principle in MV is excluded.

3.2.2 Rogowski coil principle and its measurement accuracy performance

Rogowski coils appears to be the best alternative to be used in MV networks instead of current transformer. Rogowski coil, named after Walter Rogowski, is an electrical device for measuring alternating current (AC) or high speed current pulses. The principle has been first published in 1912. Rogowski coil basic assembly is on the Fig. 3-2 [14]. It is uniformly wounded coil with non-magnetic core. It consists of a helical coil of wire with the lead from one end, returning through the center of the coil to the other end, so that both terminals are at the same end of the coil. The whole assembly is then wrapped around the straight conductor whose current is to be measured. Output voltage is proportional to the derivate of primary current according formula Eq.3-1.



$$v(t) = M \times \frac{di(t)}{dt} \quad (Eq. 3 - 1)$$

Fig. 3-2 : Basic Rogowski coil with return wire thru the winding center

Rogowski coil does not include iron core, therefore saturation effect cannot be developed and relationship between primary measured current and secondary voltage has linear character which is visible from Fig. 3-3. The same picture shows comparison with current transformer characteristics, relation of the primary and secondary current.

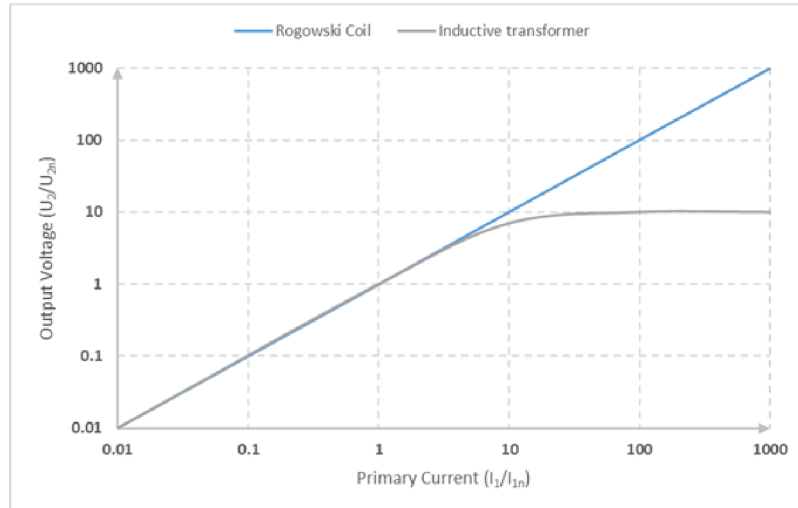

Fig. 3-3 : Schematic comparison of the Rogowski coil and IT characteristics

It is important to underline that Fig.3-1 does not express accuracy changes what comes to required dynamic range of the measurement. Inductive principle of current measurement with ferromagnetic core reaches the saturation point at the certain current level. From this point accuracy of inductive current transformer is not guaranteed. Fig.3-4 shows amplitude accuracy performance of Rogowski coil trough

entire measuring range. From the protection and metering application stand point Rogowski coil performs according requirements defined by IEC 60044-8 [5].

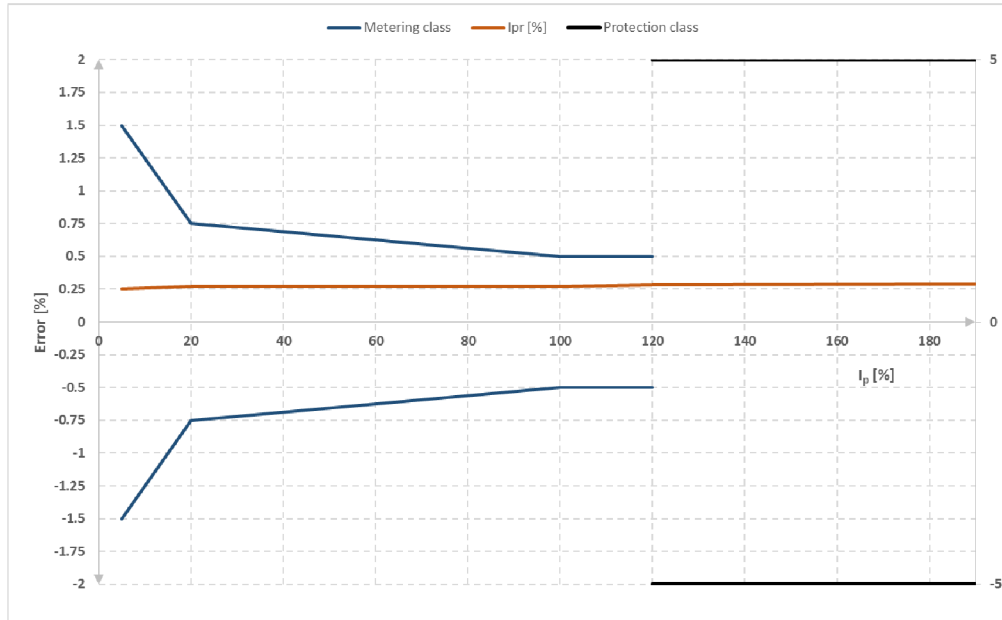

Fig. 3-4 : Combined accuracy limits of Rogowski coil at const. ambient temp. [23]

Amplitude accuracy of the Rogowski coil across entire dynamic range is constant. This is its very important characteristic. Modern IEDs provide possibility to set correction factors of the amplitude and phase measurements. Proper setting of the amplitude error correction in IED brings error of the current measurement used by IED close to 0 and this error is applicable across complete dynamic range.

3.2.3 Comparison of available voltage measurement principles

Following well know principles can be considered to be used in MV switchgears and networks.

- Resistive voltage divider
- Capacitive voltage divider
- Fiber Optic Voltage Sensing (FOVS)
- Voltage transformer based on inductive principle

Selection criteria of what are possible principles to be used for voltage measurement in MV are the same like in case of current measurement. It means accuracy class at least 0,5% and acceptable cost of product. Fig. 3-5 shows relationship between cost and accuracy of all relevant voltage measurement technologies.

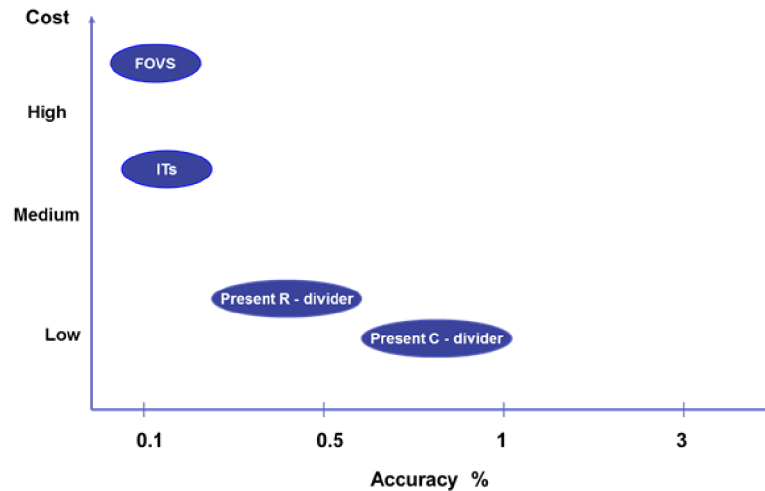

Fig. 3-5 : Relations between accuracy and costs of available voltage sensing tech.

Fiber optic voltage sensing has excellent accuracy performance and it is immune against all environmental impacts, however high cost disqualifies the application of this technology in MV.

3.2.4 Resistive and capacitive dividers principles, measurement accuracy performance

From all known voltage measurement principles the best alternative for voltage measurement in MV networks in comparison to inductive based transformers are resistive or capacitive dividers. Voltage divider (also known as a potential divider) is a linear circuit that produces an output voltage (U_s) that is proportional to its input voltage (U_p). Voltage division refers to the partitioning of a voltage among the components of the divider. A voltage divider referenced to ground is created by connecting two electrical impedances in series. Impedances can be made either by resistors (resistive divider) or capacitors (capacitive divider).

A resistive divider simple assembly can be seen on Fig. 3-6. Applying Ohm's Law, the relationship between the input voltage U_p and the output voltage U_s , is defined by Eq. 3-2.

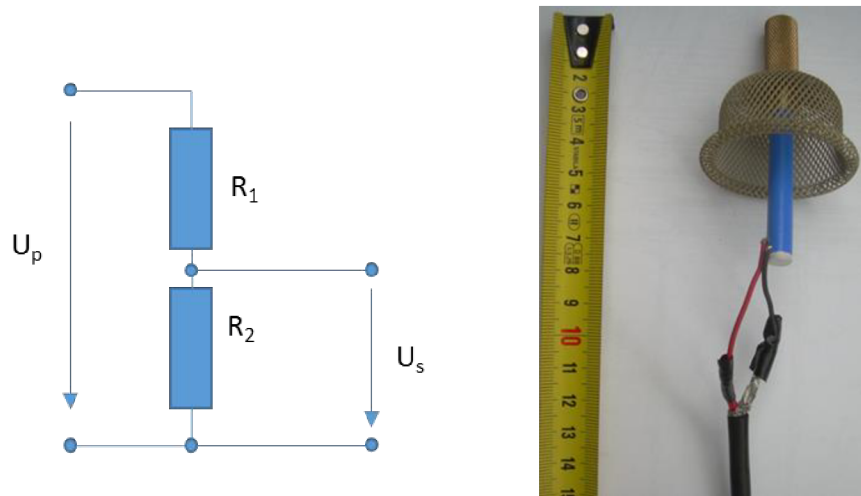

Fig. 3-6 : Left - Resistive divider scheme and Right – example of the assembly

$$U_s = \frac{R_2}{R_1+R_2} \times U_p \quad (\text{Eq.3-2})$$

A capacitive divider simple assembly can be seen on Fig.3-7. According Ohm's Law, the relationship between the input voltage U_p and the output voltage U_s , is defined by formula Eq. 3-3.

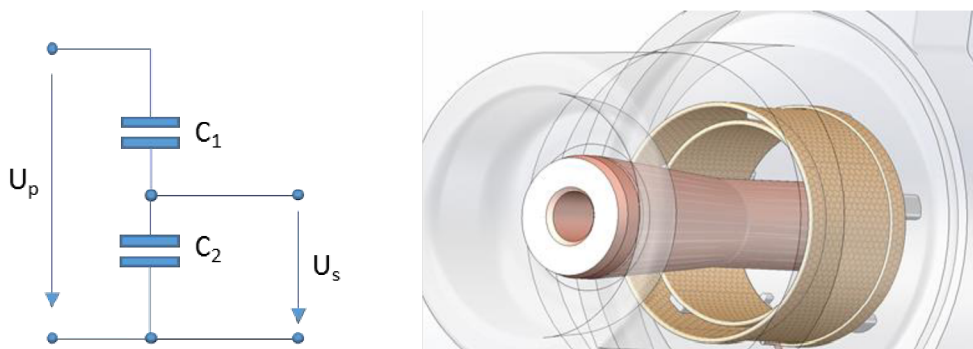

Fig. 3-7 : Left - capacitive divider scheme and Right – example of the assembly

$$U_s = \frac{c_1}{c_1+c_2} \times U_p \quad (\text{Eq.3-2})$$

Fig.3-8 shows voltage measurement amplitude error typically generated by voltage dividers. From the protection and metering application stand point both principles perform according requirements defined by IEC 60044-7 [4].

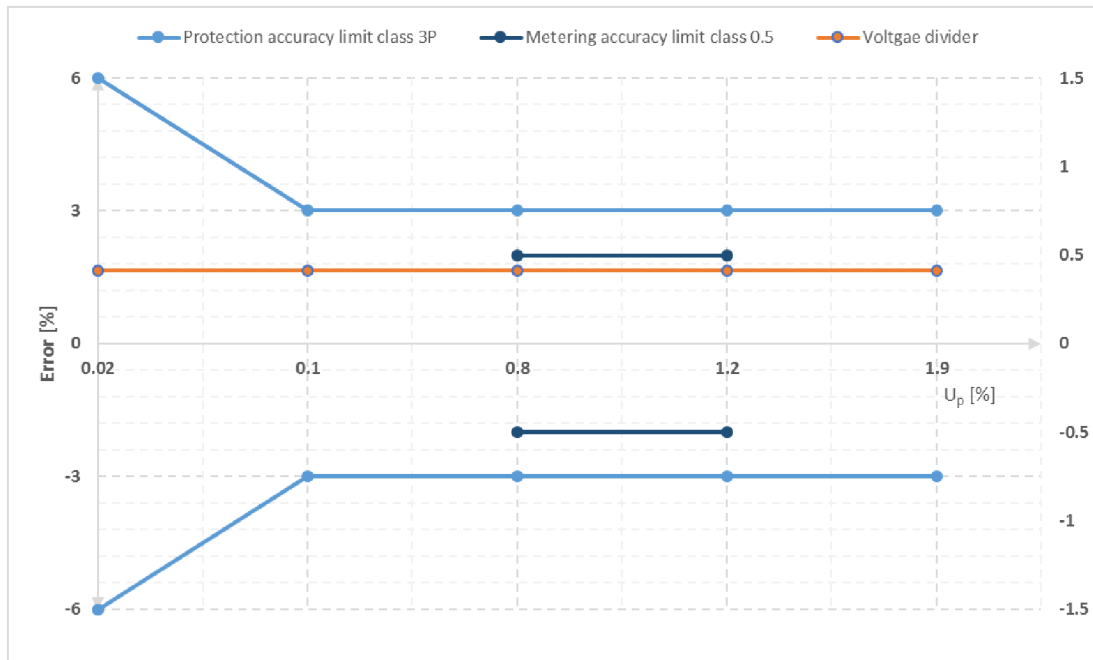

Fig. 3-8 : Voltage accuracy class of voltage divider at const. ambient temp. [23]

Modern IEDs offers possibility to define measurement correction factors as a parameter that can offset measurement error. Proper setting of correction factor in IED can bring voltage measurement error used by IED close to zero.

3.3 Control part

Control part of the MV switchgears is certainly the part where technology changes are happening in shortest cycles. Technology changes are driven by state of the art of the electronic devices for measuring, protection, control and communication. Three major steps of technology change in the area of electronic devices happened in last 40 years.

1. During 70's years of the last century from electromechanical to transistor based devices.
2. During 80's years of the last century from transistor based to single purpose microprocessor based devices.
3. During 90's years of the last century from single purpose to multifunctional microprocessor based devices.

Further technology changes in electronic devices during this century are driven by higher performance of microprocessors and changes in electronic device architecture that allows faster and higher data processing thru communication interface. Absolutely latest technology change has been implementation of Ethernet communication that allows to communicate very high traffic of data where even real time sampled measured data can

be shared on communication bus. These latest electronic devices are important enabler for future changes in substation architecture and it is assumed their commercial availability for the purpose of this thesis. Thesis as such does not deal with IED (intelligent electronic device) hardware and software architecture. It is assumed that IED with required analog and digital interface is commercially available. Example of such commercially available IED is ABB REF 615 which will be used for the purpose of this thesis. Other manufacturer IEDs are also available however there will not be explored within the scope of this thesis.

3.3.1 Measurements distribution in substation

Current and voltage measurements in MV substation are very often distributed and shared in entire substation. Due to the fact that output of the Rogowski coil and voltage divider is low voltage output signal, it is certainly higher technical challenge to distribute it within substation in comparison to signal output of the current or voltage transformers. This has always been application limit factor when introducing sensors in MV switchgears in the past. In year 2003 IEC 61850 has been introduced. Beside many other aspects of substation automation and communication this standard defines and unifies in section 9-2 how to sample measured values, in other words how to digitalize measurements. Measurements in digital format available on high speed communication bus can be shared for any purposes. In fact it overcomes any protection application constraints as results of above mentioned challenge of low voltage analog signal distribution and sharing.

3.3.2 Basic Introduction of IEC 61850 [6]

The possibility to build SAS (Substation Automation System) depends on the strong technological development of large-scale integrated circuits, leading to the present availability of advanced, fast, and powerful microprocessors. The result was an evolution of substation secondary equipment, from electro-mechanical devices to digital devices. This in turn provided the possibility of implementing SAS using several intelligent electronic devices (IEDs) to perform the required functions (protection, local and remote monitoring and control, etc.). As a consequence, the need arose for efficient communication among the IEDs, especially for a standard protocol. Up to now, specific proprietary communication protocols developed by each manufacturer have been used, requiring complicated and costly protocol converters when using IEDs from different vendors.

The industry's experience has demonstrated the need and the opportunity for developing standard communication protocols, which would support interoperability of IEDs from different manufacturers. Interoperability in this case is the ability to operate on the same network or communication path sharing information and commands. There is also a

desire to have IED interchangeability, i.e. the ability to replace a device supplied by one manufacturer with a device supplied by another manufacturer, without making changes to the other elements in the system. Interchangeability is beyond this communication standard. Interoperability is a common goal for electric utilities, equipment vendors and standardization bodies. In fact, in recent years several National and International institutions started activities to achieve this goal.

The objective of SAS standardization is to develop a communication standard that will meet functional and performance requirements, while supporting future technology developments. To be truly beneficial, a consensus must be found between IED manufacturers and users on the way such devices can freely exchange the data.

The communication standard must support the operation functions of the substation. Therefore, the standard has to consider the operational requirements, but the purpose of the standard is neither to standardize (nor limit in any way) the functions involved in substation operation nor their allocation within the SAS. The application functions will be identified and described in order to define their communication requirements (for example, amount of data to be exchanged, exchange time constraints, etc.). The communication protocol standard, to the maximum possible extent, should make use of existing standards and commonly accepted communication principles.

The approach is to blend the strengths of the following three methods:

- Functional decomposition, data flow, and information modeling. Functional decomposition is used to understand the logical relationship between components of a distributed function, and is presented in terms of logical nodes that describe the functions, sub functions and functional interfaces.
- Data flow is used to understand the communication interfaces that must support the exchange of information between distributed functional components and the functional performance requirements.
- Information modeling is used to define the abstract syntax and semantics of the information exchanged, and is presented in terms of data object classes and types, attributes, abstract object methods (services), and their relationships.

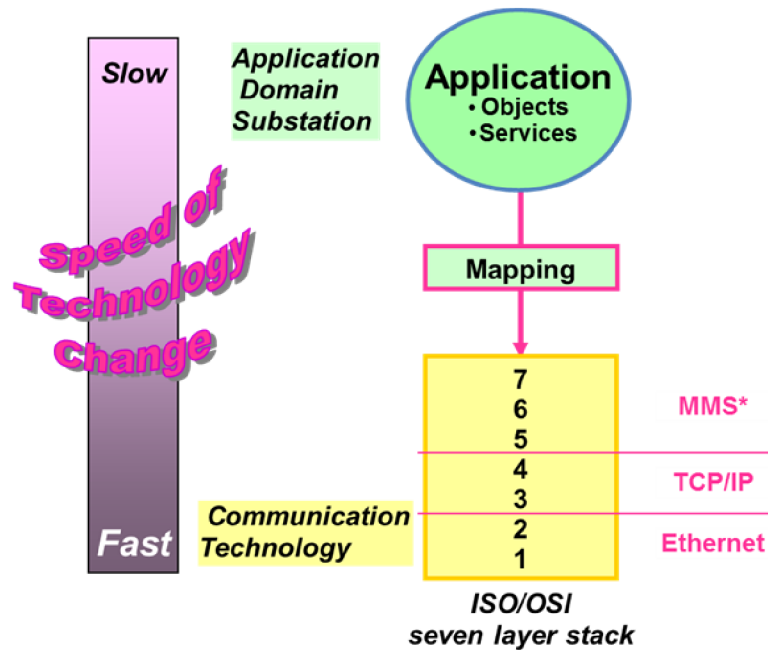

Fig. 3-9: IEC 61850 Approach [6]

Primary equipment technology changes are slow, while communication technology changes are fast. One of the key approaches, of IEC 61850 is split between these two different segments by means of abstract mapping substation functions to ISO/OSI layers as shown on Pic 3-9.

IEC 61850 is much more than communication protocol. It defines communication networks and systems in substations including engineering approach. The abstract data models defined in IEC 61850 can be mapped to any protocol. Current mappings in the standard are

1. MMS (Manufacturing Message Specification). Communication between IEDs and SCADA system
2. GOOSE (Generic Object Oriented Substation Event). Communication among IEDs
3. SMV (Sampled Measured Values). Communication between process level (e.g. sensor, actuator) and station system.

Application domain of IEC 61850 in substation begins at process interface (e.g. sensors or actuators) and goes across bay level represented by IEDs up to station level represented by station computer or station gateway. It does not go beyond substation computer or station gateway. This is clearly expressed in Fig. 3-10

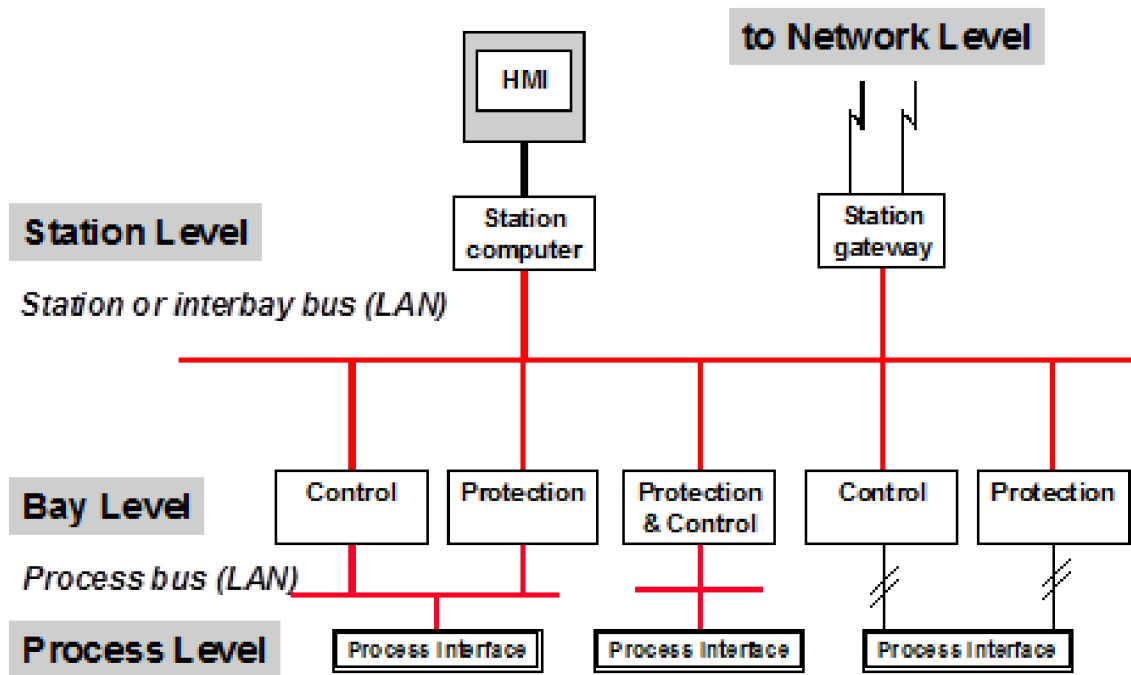

Fig. 3-10 : Application domain of IEC 61850 in Substation

4 TARGETS OF THE DOCTORAL THESIS

This thesis will focus to exploration of the application of two technologies - measuring of currents and voltages by Rogowski coil and voltage dividers and communication bus using IEC 61850-9-2 [7] in MV switchgears. Both technologies as such, have been independently subject of the investigations and explorations in many papers and publications. This thesis will propose and verify simultaneous combination of both technologies implemented and practically verified in MV Switchgear. It will offer clear view, why both technologies deployed hand in hand will create a new opportunities how to protect and control MV switchgears and networks in a different manner. Further target is to explain why Rogowski coil and voltage dividers are better alternative to well-known inductive transformers for current and voltage measurements in MV switchgear. Additional target is to offer technical arguments of what is the next step is architecture of MV switchgears. Thesis offers a system view on MV switchgear, it will explain how to connect loose well known components: sensors – IEDs – digital bus to one seamless architecture and it will demonstrate how this integration will impact MV switchgear engineering and design approach.

The first part of the thesis will be focused to detailed investigation of possible measurement accuracy influence by external factors in indoor substation environment. Based on the experimental measurements thesis will investigate how good is immunity of the Rogowski coil and voltage dividers against external factors that influence accuracy of the measurement.

The second part will propose alternative approach in residual current measurement by Rogowski coil and IED processing in comparison to existing practice of the residual current measurement by core balance transformer. It will analyze applicability of the alternative measurement and processing of residual current in insulated and directly grounded networks.

The third part will define new system architecture of the MV air insulated switchgear with seamless integration of the sensors, IEDs and digital bus in the switchgear and substation. It will propose new typical layouts of the MV feeders needed to design MV substation. It will investigate how the new typical layouts can change engineering approach. Important aspects of communication network reliability and availability will be verified for proposed architecture.

The final part will demonstrates practical application of the new proposed architecture deployed in real product and applied in real substation.

5 INFLUENCE OF EXTERNAL FACTORS ON SENSORS ACCURACY

5.1 General introduction and assumptions

Every measuring device has certain measuring error given by its physical principle of the measurement. This error is however not the final error. There are many external factors which may influence total measurement accuracy of any instrumental device for the measurement, including Rogowski coil and voltage dividers. External factors influencing measuring error of the sensors can be divided into three categories.

- I. External factors that can be eliminated by proper design
- II. External factors given by the application environment
- III. External factors generated by the architecture of the measuring system

Ad I. External factors that can be eliminated by proper design.

These factors were not investigated within this thesis taken into account assumption that design of the final product eliminates them. This category includes following external factors.

- High dielectric fields
- High magnetic fields (magnetic cross-talks)
- Eddy currents
- Vibrations, shock and tilting
- Altitude

Ad II. External factors given by the application environment

There are two general environmental application in MV networks defined by IEC 62271-1 [1] outdoor and indoor. This thesis is focused to investigation of temperature influence on total measuring error since this variable has major influence in indoor MV applications. Other environmental factors that can influence measurement accuracy when outdoor conditions are considered are following.

- Humidity
- Pollution
- UVA & UVB

Ad III. External factors generated by the architecture of the measuring system

The third category includes factors generated by the architecture of the measuring system. The current view about requirement of accuracy class measurement in MV applications is generally limited to accuracy class of sensing element (instrument transformer or sensor). This view is however not correct, because total measurement error is sum of errors contribution of each and every element in measuring chain. Complete measuring chain is clearly explained in IEC 60044-8 [5] and can be seen from Fig. 5-1.

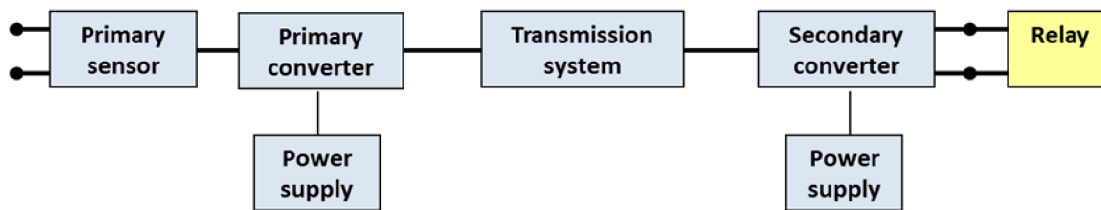

Fig. 5-1 : Definition of measurement accuracy chain according IEC 60044-8 [5]

Picture above defines measurement accuracy chain applicable both form MV and HV applications. There is no need to use primary and secondary active converter in MV applications due to the limited distance between primary sensor and relay. Transmission system represented by the cable between primary sensor and the relay is however element where it is very important to understand its possible influence on measuring accuracy. Finally also analog input of the relay, its nominal burden and design has influence on the measuring accuracy. Each manufacturer of the relay has analog inputs board optimized for the signals generated by the particular sensors. For the purpose of this thesis, ABB relay REF 615 was used, where analog input board is designed taking into account character of the signal sensors specified below in this chapter. All measurements were done by use of Ethernet communication cable CAT6 which represents transmission system on Fig.5-1.

Accuracy and the measurement quality of the sensors can be influenced by the design, manufacturing and assembly methods, therefore all results are relevant only for ABB sensors used for the purpose of this thesis. However, combination of sensor – IED – AIS architecture coming from different manufacturers could be investigated in an identical way. All investigations and measurements were done on following three types of ABB sensors KEVCD 24 AE3 - parameters are specified in Appendix 1, KEVA 24 C21 – parameters are specified in Appendix 2 and KEVCY 24 RE1 – parameters are specified in Appendix 3, KEVCR 17.5 CA1 - parameters are specified in Appendix 4.

5.2 Sensors amplitude and phase measuring accuracy as function of temperature

5.2.1 General arrangements and rational of the measurement

Fig.3-4 resp. 3-8 shows typical Rogowski coil and voltage divider measurement error considering constant ambient temperature. This is however ideal situation. MV equipment in switchgear must reliably perform under various temperature conditions. Operating temperature inside MV switchgear under service conditions is given by the sum of ambient temperature and temperature rise generated by operating current flow through the primary part of the switchgear. As first step we investigated relations between the temperature around sensors and their measurement accuracy. Details of measurements can be found in Appendix 5.

5.2.2 Parameters of the measurement

Sensor KEVCD 17.5 CA1 was used for the test. Three temperature cycles were measured for the Rogowski coil, resistive and voltage divider.

- Operating temperature cycle as shown in Fig.5-2. This is most likely temperature range around the sensors during their life cycle. Temperature range from -5°C ... $+40^{\circ}\text{C}$ was used. This is also operating ambient temperature range defined by the most of the manufactures for their MV switchgears. Test duration of 15 hours was defined in order to reach stabilized accuracy of the measurement.
- Storage temperature cycle as shown in Fig.5-3. Temperature range from -25°C ... $+80^{\circ}\text{C}$ was selected. The focus was given to investigation of higher temperature as no accuracy issues are expected at low temperatures. Duration of 30 hours was defined for the test.
- Extended temperature cycle as shown in Fig.5-4. The target was to verify accuracy of the sensors in extremities, therefore temperature range from -40°C ... $+115^{\circ}\text{C}$ was defined. The value of $+115^{\circ}\text{C}$ is defined by IED 62271-1 a maximum limit of temperature for the MV switchgear and controlgear. Test duration of 45 hours was selected. This is most important temperature cycle since ambient temperature in MV switchgear can reach the value of 110°C .

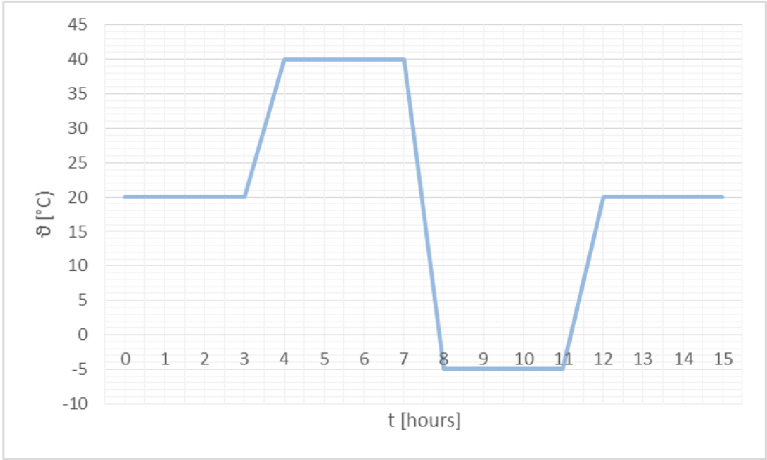

Fig. 5-2 : Operating temperature test cycle of the sensor accuracy

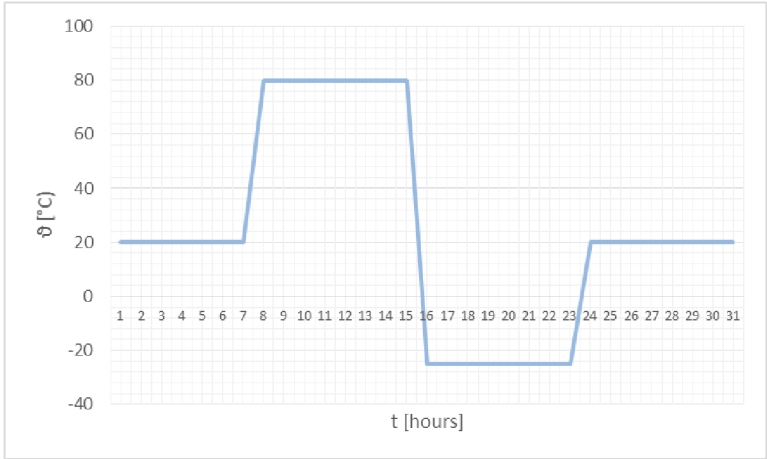

Fig. 5-3 : Storage temperature test cycle of the sensor accuracy

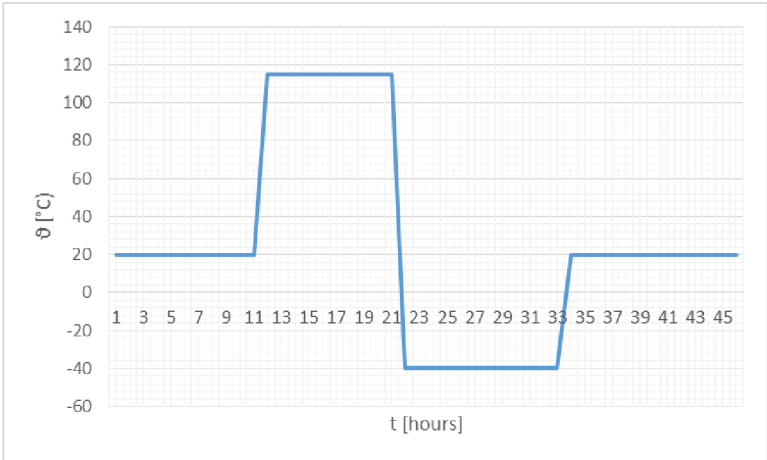

Fig. 5-4 : Extended temperature test cycle of the sensor accuracy

5.2.3 Results and conclusions – Rogowski coil

Accuracy classes for the current measurement are defined by IEC 60044-8 [5] separately for the metering and protection part. Limit values can be seen in Tab.5-1 and Tab.5-2

Tab. 5-1 : Current transformers protection accuracy classes acc. IEC 60044-8 [5]

Accuracy class	Current error at rated primary current [%]	Phase error at rated primary current		Composite error at rated accuracy limit Primary current [%]	At accuracy limit condition Maximum peak instantaneous error [%]
		Minutes	Centiradians		
5TPE	± 1	± 60	± 1.8	5	10
5P	± 1	± 60	± 1.8	5	-
10P	± 3	-	-	10	-

Tab. 5-2 : Current transformers metering accuracy classes acc. IEC 60044-8 [5]

Accuracy class	± percentage current (ratio) error at percentage of rated current shown below				± phase error at percentage of rated current shown below							
					Minutes				Centiradians			
	5	20	100	120	5	20	100	120	5	20	100	120
0.1	0.4	0.2	0.1	0.1	15	8	5	5	0.24	0.24	0.15	0.15
0.2	0.75	0.35	0.2	0.2	30	15	10	10	0.9	0.45	0.3	0.3
0.5	1.5	0.75	0.5	0.5	90	45	30	30	2.7	35	0.9	0.9
1.0	3.0	1.5	1.0	1.0	180	90	60	60	5.4	2.7	1.8	1.8

NOTE: The limit of current error and phase error predescribed for 120% of rated primary current should be retained up to the reated extended primary current.

Complete test results for defined temperature cycles are documented in Appendix 5. Tab.5-3 shows the results of the measurement in extended temperature cycle.

Tab. 5-3 : Extended temperature cycle, accuracy of the Rogowski coil

Cycle # 3 - Extended temperature range						
Temperature	°C	+20	+115	+20	-40	+20
ϵ	%	0.40	0.44	0.44	0.43	0.39
$\Delta\epsilon$	%	-	+0.04	+0.04	+0.03	-0.01
φ	min	6.0	32.4	12.6	3.6	10.2
$\Delta\varphi$	min	-	+26.4	+6.6	-2.4	+4.2

Rogowski coil meets accuracy class 0.1 according IEC 60044-8 [5] both for metering and protection part.

Amplitude error: Contribution of amplitude error as function of temperature change is a negligible constant value for all tested temperature cycles. Constant value of the amplitude error allows to define constant value of correction factor in IED and offset measuring error of the Rogowski coil principle in IED below accuracy class 0.1 across very large current dynamic range and temperature range.

Phase error: Contribution of phase error as function of temperature shows small and constant values for typical operating temperature ranges. Rogowski coil meets limits accuracy class of 0.1 specified by IEC 60044-8 [5]. Constant pattern of the phase error allows to define constant correction factor in IED and offset phase error measurement for further processing in IED close to zero. Contribution of phase error for low temperatures shows small dependency, but still within limits defined by the standard for protection accuracy class 5TPE. As far as the high temperatures are concerned, considerable phase displacement error was seen. For the MV applications where high temperatures are likely to appear Rogowski coil can meet 0.5 accuracy class limits according to IEC 60044-8 [5].

Rogowski coil meets all limits defined by IEC60044-8 for protection and metering purposes and temperature influence does not impact accuracy required for protection applications and metering applications.

5.2.4 Results and conclusions – Capacitive voltage divider

Accuracy classes for voltage measurement are defined by IEC 60044-7 [4]. Limit values can be seen in Tab.5-4.

Tab. 5-4 : Voltage transformers combined accuracy classes acc. IEC 60044-7 [4]

Class	Percentage voltage (ratio) error \pm	Phase displacement \pm	
		Minutes	Centiradians
0.1	0.1	5	0.15
0.2	0.2	10	0.3
0.5	0.5	20	0.6
1.0	1.0	40	2
3.0	3.0	Not specified	Not specified

Complete test results for defined temperature cycles are documented in Appendix 5.

Capacitive divider measuring error is significantly influenced by the temperature changes. Tab.5-5 shows accuracy deviation of capacitive divider as function of temperature. Both amplitude and phase error show changes in accuracy depending on temperature. Capacitive divider does not meet accuracy classes limits according IEC 60044-7 [4] across typical temperature operating range for indoor MV applications. This fact does not exclude possible application in MV, however dependency of capacitive divider on temperature must be taken into account when considering to use this technology in MV applications. Errors are not constant which excludes possibility to offset error by setting correction factor in IED.

Tab. 5-5 : Extended temperature cycle, accuracy of the capacitive divider

Cycle # 3 - Extended temperature range						
Temperature	°C	+20	+115	+20	-40	+20
ϵ	%	-3.99	-38.40	-5.34	-6.61	-4.00
$\Delta\epsilon$	%	-	+42.39	-1.35	-2.62	-0.01
φ	min	0.3	220.7	0.3	-53.2	0.1
$\Delta\varphi$	min	-	+220.4	+0.0	-53.5	-0.2

5.2.5 Results and conclusions – Resistive voltage divider

Complete test results as well as details of the measurement are documented in Appendix 6.

Resistive divider amplitude measuring error is constant and temperature influence plays negligible role in overall amplitude accuracy. Tab.5-6 shows accuracy of the resistive divider within operating temperature range. It can be concluded that resistive divider measurement accuracy is immune to temperature changes within operating temperature range. Resistive divider technology as such without correction factors in IED meets voltage accuracy class 0.5 according IEC 60044-7 [4] across large temperature range. Thanks to constant pattern of the amplitude error correction factor can be precisely defined in IED which offset amplitude measurement error close to zero for further processing in IED. Resistive divider phase displacement error shows small dependency on temperature. This value do not exceed limits of voltage accuracy class 0.5 specified by IEC 60044-7 [4]. It can be concluded that temperature has negligible contribution error to phase displacement of resistive dividers. Constant pattern of phase displacement error regardless on temperature allows to define correction factor in IED which offset phase displacement error close to zero for further processing in IED.

Tab. 5-6 : Extended temperature cycle, accuracy of the resistive divider

Cycle # 3 - Extended temperature range						
Temperature	°C	+20	+115	+20	-40	+20
ϵ	%	1.83	2.25	1.87	2.30	2.10
$\Delta\epsilon$	%	-	0.42	0.04	0.47	0.27
φ	min	12.10	20.70	12.05	11.40	11.50
$\Delta\varphi$	min	-	8.60	-0.05	-0.70	-0.60

5.3 Sensors amplitude and phase measurement accuracy as function of the cable length between sensor and IED - Basic accuracy test

5.3.1 General arrangements and rational of the measurement

Output signal from the sensors has low voltage level. Transfer of low voltage signals through long cables has limits. It is important to verify whether the typical distances between primary sensor and IED in MV application influence accuracy of the measurement. Basic accuracy test of sensor and cable according IEC 600447-7 cl.8.3.1 for voltage dividers, respectively IEC 60044-8 [5] cl.8.9.2 were followed in order to verify possible dependency of measurement error as function of cable length.

5.3.2 Parameters of the measurement

Cables length of 6.5 m, 20 m, 50 m and 100 m were investigated. All selected lengths represent certain application distance between primary sensor and the IED.

- 6.5 m – typical cable length between sensor and relay within one panel
- 20 m – typical cable length between sensor and relay within one section of the MV substation
- 50 m – maximum cable length between sensor and relay within entire MV substation
- 100 m – maximum cable length between sensor located next to the power transformer and relay located in MV switchgear

5.3.3 Results and conclusions – Rogowski coil

Detailed result and measurement description are documented in Appendix 7. Tab.5-7 shows results of the Rogowski coil measurement accuracy dependency on cable length.

Cable length does not influence amplitude error of the measurement. Deviations are negligible. Measuring error for different cable lengths has constant pattern. This allows to define constant amplitude correction factor in IED and offset measuring error to zero for further processing in IED.

Cable length is shifting phase considerably. This needs to be taken into account for particular metering or protection application. Phase displacement error for each particular cable length is constant. This allows to define constant phase correction factor in IED and offset measuring error to zero for further processing in IED.

It can be concluded that cable length between Rogowski coil and IED is not limiting factor of the MV application. It is important to define correction factors given by measuring error of amplitude and phase displacement of the particular Rogowski coil and cable length. Setting of correction factors in IED allows to consider accurate measuring input data for further processing in IED.

It is important to use well shielded cable between Rogowski coil and IED with sufficient terminations and grounding on both ends. Tests proven that Ethernet cable CAT 5 used as transmission element between primary sensor and IED meets required levels of accuracy classes defined by IEC 60044-8 [5] for metering and protection.

Tab. 5-7 : Rogowski coil measurement accuracy as function of cable length

Current and phase errors (ε_i , φ_i) of current sensor s.n. 1VLT5411010801						
Length [m]	Test current		0.05 I_r	0.20 I_r	I_r	15.625 I_r ¹⁾
6.5	ε_i	[%]	0.833	0.82	0.817	0.854
	φ_i	[']	-5.62	-5.59	-5.44	-6.45
20	ε_i	[%]	0.855	0.821	0.826	0.847
	φ_i	[']	-9.13	-9.41	-9.45	-9.62
50	ε_i	[%]	0.875	0.848	0.842	0.845
	φ_i	[']	-14.59	-14.79	-14.57	-16.52
100	ε_i	[%]	0.825	0.798	0.802	0.822
	φ_i	[']	-34.13	-37.42	-38.24	-37.05

¹⁾ Correction value (0.150%) of amplitude added - related to measured values at 80A

5.3.4 Results and conclusions – Resistive voltage divider

Detailed results and measurements descriptions are documented in Appendix 7. Tab.5-8 shows resistive voltage divider measurement accuracy dependency on cable length between primary sensor and IED. Considerable error both in amplitude and phase displacement can be seen from the measurement results of the long cables with resistive voltage divider. Amplitude error for the particular cable length and typical voltage measuring range in MV shows constant character. This allows to define constant correction factor in IED and offset amplitude measuring error for further processing in IED. Phase error for the particular cable length and typical voltage measuring range in MV shows constant character. This allows to define constant correction factor in IED and offset amplitude measuring error for further processing in IED. IED must have capability to set amplitude and phase correction factors when resistive voltage dividers are used otherwise measuring error can negatively influence accuracy of voltage measurements for metering or protection purposes. Accuracy classes for voltage measurement specified by IEC 60044-7 [4] can be met when correction factors in IED are properly set only.

Tab. 5-8 : Resistive voltage divider meas. accuracy as function of cable length

Amplitude and phase errors (ε_u, φ_u) of voltage sensor s.n. 1VLT5411010801						
Length [m]	Test Voltage		0.05 U_n	0.8 U_n	U_n	1.9 U_n
6.5	ε_u	[%]	-0.329	-0.263	-0.244	-0.142
	φ_u	[']	18.07	-2.2	-2.44	-3.14
20	ε_u	[%]	-0.369	-0.33	-0.311	-0.207
	φ_u	[']	-16.53	-36.72	-36.94	-37.63
50	ε_u	[%]	-0.479	-0.513	-0.497	-0.392
	φ_u	[']	-95.14	-114.82	-115.11	-115.67
100	ε_u	[%]	-0.803	-0.917	-0.902	-0.8
	φ_u	[']	-229.34	-244.56	-244.88	-245.2

5.4 Sensors amplitude and phase measurement accuracy as function of frequency – Frequency response

5.4.1 General arrangements and rationale of the measurement

Accurate measurement of the higher harmonics becomes important attribute in MV applications. Some of the protection functions requires to measure up to 7th harmonics for their proper fault detection. Demands for high harmonics measurements in metering applications is even more important. Accurate measurement of high harmonics determinates accurate calculation of power quality parameters. High harmonics up to 25th

harmonics are required to be measured for metering application. It is important to verify accuracy of the higher frequencies measured by sensors.

5.4.2 Parameters of the measurement

Two frequency spectra were selected where amplitude and phase displacement error were measured. First spectrum corresponds to protection applications 50 Hz – 350 Hz in order to verify accuracy of 2nd, 3rd, 5th and 7th harmonics. Protection requirements on transient response of voltage and current acquisition chain can be found in [16]. Second spectrum investigates accuracy of amplitude and phase displacement measurement for metering applications 40 Hz – 1500 Hz. This allows to see accuracy of the measurement up to 25th harmonics. Measurements with different cable lengths for Rogowski coil and resistive voltage divider were done in order to verify possible influence of cable length on measurement accuracy of high harmonics. The same cable length of 6.5 m, 20 m, 50 m and 100 m as in previous measurement were selected.

5.4.3 Results and conclusions – Rogowski coil

Detail data and measurement are documented in Appendix 7. Fig.5-5 shows amplitude error of current measurement by Rogowski coil from 40 Hz – 1250 Hz and Fig.5-6 phase displacement for the same frequency range.

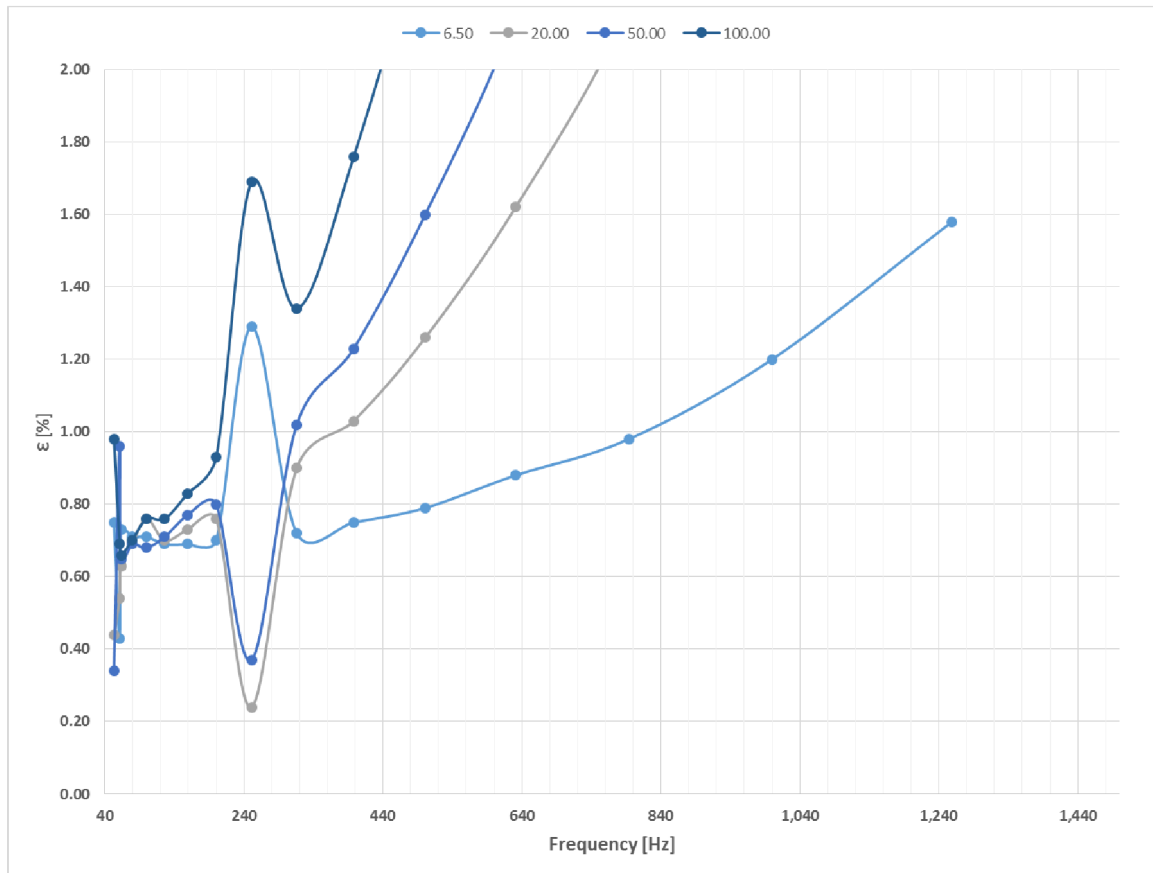

Fig. 5-5 : Frequency response of Rogowski for various cable lengths

Rogowski coil transfers high harmonics for protection purposes with max 1.7% amplitude error. Cable length has minimum impact on amplitude accuracy measurement. Certain resonance effect is seen around 250 Hz for all cable length. The effect as such is undesirable, however measuring error associated with this effect will have negligible impact on selectivity and accuracy of the protection system. There is a possibility to eliminate resonance effect by changing of the sensor and cable total inductance, however this would not be worth due to the additional production costs. This behavior confirms previous conclusion of minimum impact of cable length on measurement accuracy. Phase displacement error is dependent on cable length, however even 100 m long cable at 350 Hz shifts the phase less than 2° which fully meets accuracy limit values defined by IEC 60044-8 [5].

Analysis of the Rogowski coil measurement accuracy in higher frequency spectrums, it means for metering purposes shows marginal influence on amplitude and phase displacement errors of the high harmonics measured by the Rogowski coil. Rogowski coil with cable up to 6.5 m length only meets accuracy limits defined by IEC 60044-8 [5]. Cable length must not exceed 6.5 m if accurate measurement of high harmonics for

energy quality purposes is required. In this case physical distance between primary sensor and IED must be as short as possible,

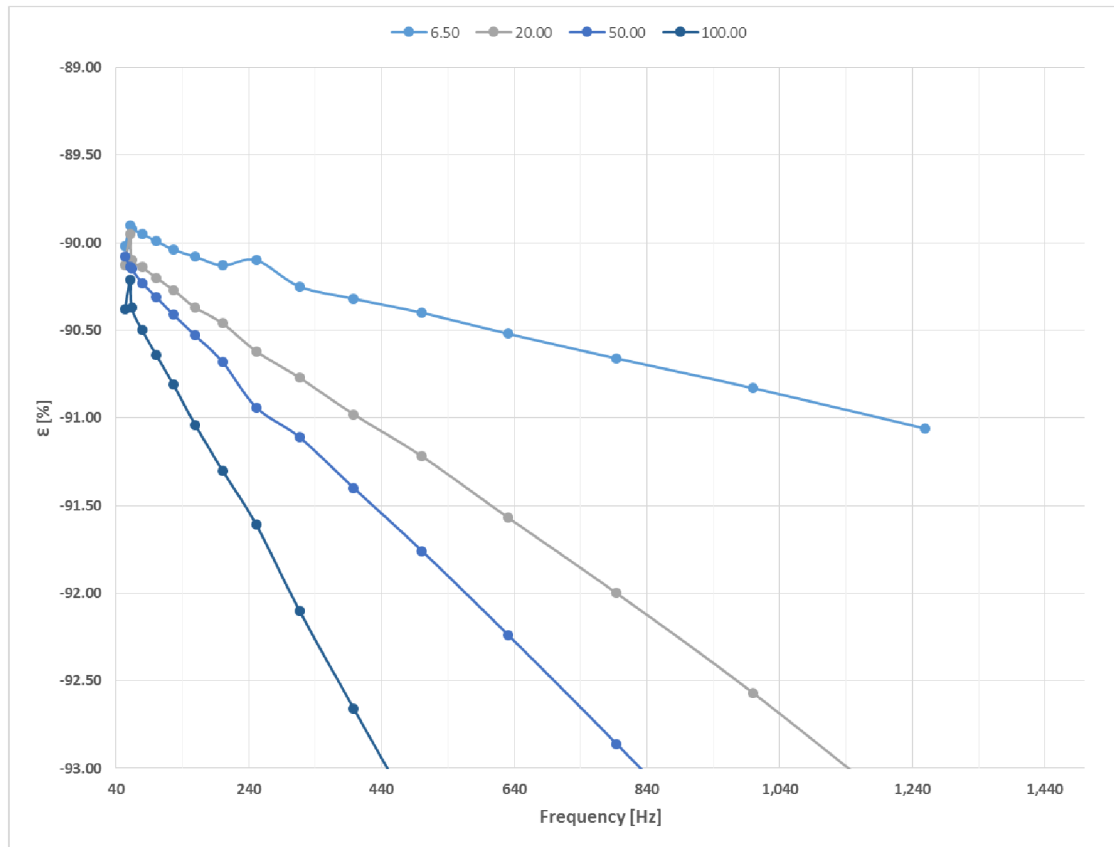

Fig. 5-6 : Frequency response of Rogowski for various cable lengths

5.4.4 Results and conclusions – Resistive voltage divider

Detail data and measurement are documented in Appendix 7. Fig.5-7 shows amplitude error of current measurement by resistive divider from 40 Hz to 1250 Hz and Fig.5-8 phase displacement for the same frequency range.

Resistive divider with the cable up to 20 m meets accuracy limits defined by IEC 60044-7 [4] of amplitude accuracy measurement for protection purposes up to 7th harmonics. Measurement errors have constant character therefore it is possible to define appropriate amplitude correction factors parameters which can offset amplitude measuring error close to zero for further processing by IED. Resistive divider with the cable up to 6.5 m meets accuracy limits defined by IEC 60044-7 [4] of phase displacement error less than 3° for protection proposes up to 7th harmonics. Measurement error has constant character therefore it is possible to define appropriate phase correction factors parameters which can offset phase displacement measuring error close to zero for further processing by IED.

As far as the metering spectrum high harmonics are concerned, resistive divider has following limits. In order to meet required limit values of IEC 60044-7 [4] distance between primary sensor and IED must not exceed 6.5 m and measurements up to 600 Hz or 12th harmonics can be considered as accurate. Resistive divider does not meet measurement accuracy limit classes defined by IEC 60044-7 [4] for the cable lengths above 6.5 m and frequencies higher than 600 Hz.

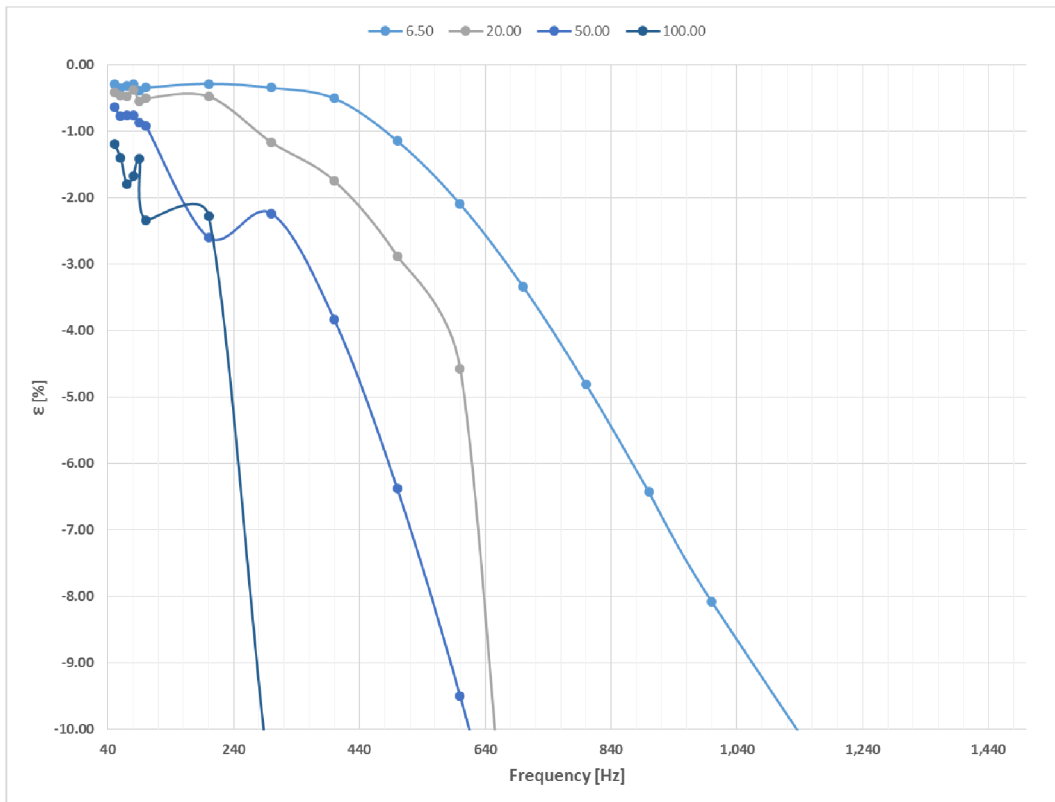

Fig. 5-7 : Frequency response of Resistive divider for various cable lengths

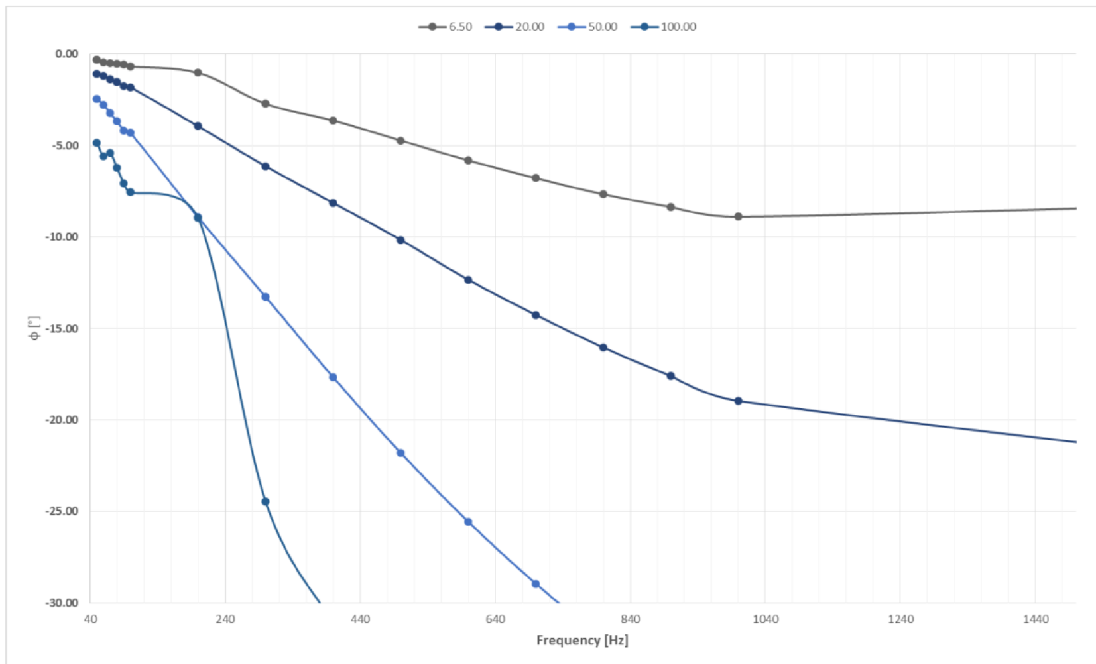

Fig. 5-8 : Frequency response of Resistive divider for various cable lengths

5.4.5 Results and conclusions – Capacitive voltage divider

Detail data and measurement are documented in Appendix 8. Fig.5-9 shows amplitude error of current measurement by capacitive divider from 40 Hz to 1250 Hz and Fig.5-10 phase displacement for the same frequency range.

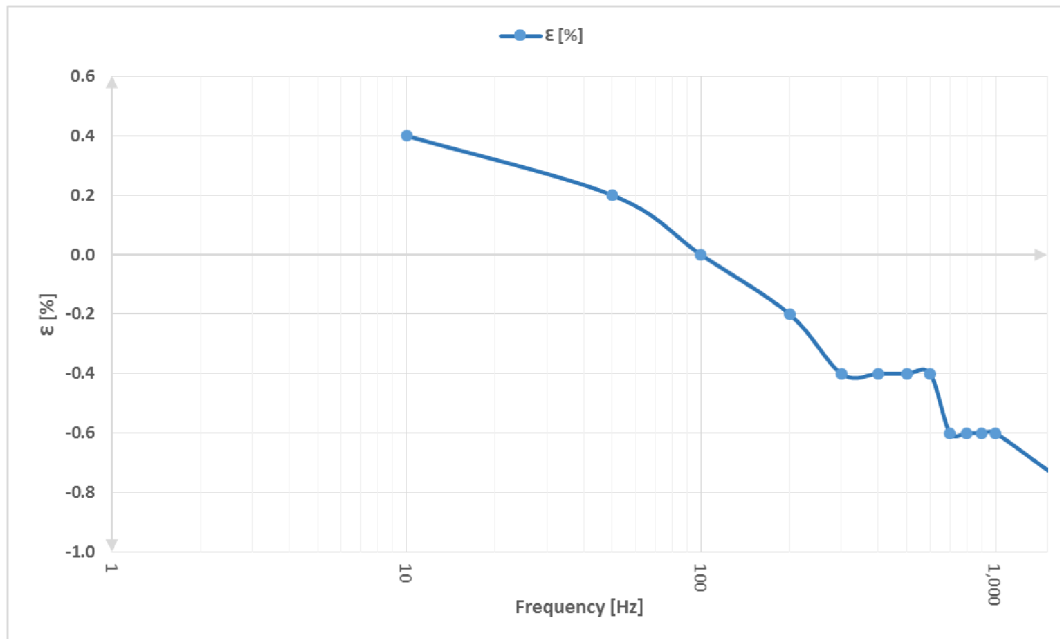

Fig. 5-9 : Frequency response of capacitive divider for 6.5 m cable length

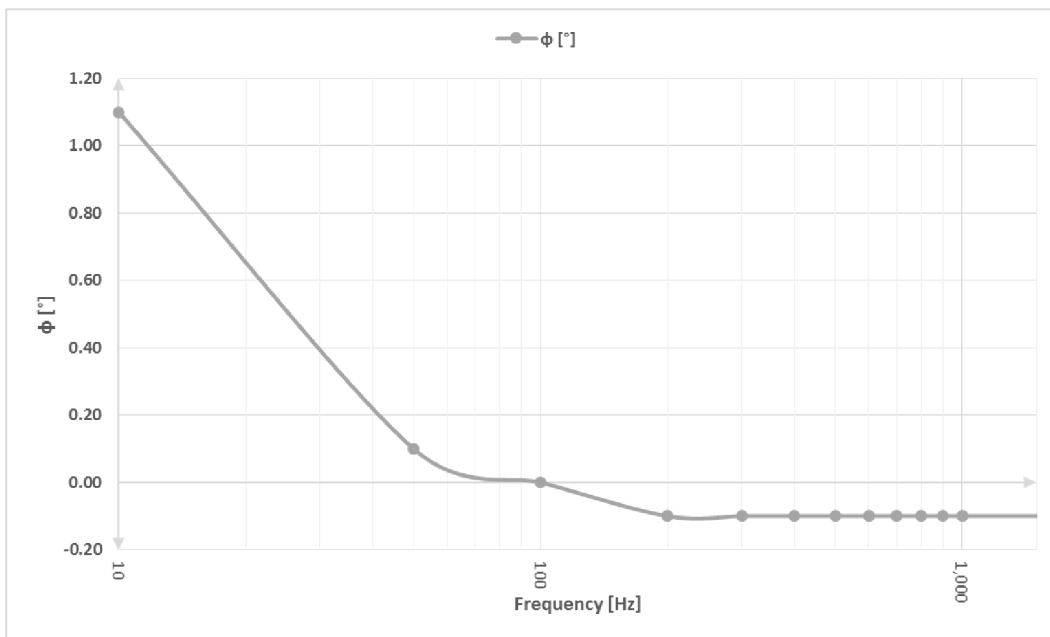

Fig. 5-10 : Frequency response of capacitive divider for 6.5 m cable length

Capacitive divider frequency response by means of amplitude and phase displacement error shows excellent performance. Amplitude error up to 25th harmonics does not exceed 0.5% and has constant character. Phase displacement error does not show any deviations across entire measured frequency spectrum. Capacitive divider meets accuracy limits defined by IEC 60044-7 [4] for entire measured frequency range.

Capacitive divider in fact works as high harmonics impedance divider which can transform high harmonics measured voltages without accuracy displacement.

Capacitive divider is the best voltage metering option when accurate energy quality measurement and analysis is required.

5.5 Overall conclusions on applications of Rogowski coil, resistive and capacitive divider in MV networks and switchgears

Rogowski coil

Accuracy is acceptable for the application in MV networks and switchgears. Contribution error generated by environmental temperature typical in MV applications does not influence results of overall accuracy neither in amplitude nor in phase displacement.

Cable length between Rogowski coil and IED has very small impact on measurement accuracy, therefore use of Rogowski coil for current measuring in case protected object is up to 100 m from IED (e.g. Transformer, Motor) is possible. Frequency response of Rogowski coil for protection purposes fully meets requirements of high harmonics accuracy measurements for protection purposes. When using Rogowski coil for measuring of high harmonics for power quality purposes where high accuracy of the high harmonics measurements is required, Rogowski coil must be placed as close as possible to IED. Cable length between Rogowski coil and measuring device which does not exceed 6.5 m transfer high harmonics up to 25th with satisfactory accuracy. Very important conclusion is that all contributing errors across measured ranges of temperatures, cable length or frequencies shows constant pattern. This allows to set correction factors in IEDs and offset any measurement error close to zero. If the correction factor is properly defined and set in IED, assumption of having current measured with no measuring error for processing in IED can be made. Results are summarized in Tab.5-9.

Tab. 5-9 : Rogowski coil meas. errors influence by external fac. (App. 5, 6, 7, 8)

			Rogowski Coil	
			Dependency	Pattern of the error
Temperature -40°C - 115°C	Amplitude error		0.02% ... 0.04%	Constant
	Phase dis. Error		0.12°... 0.5°	Constant
Distance to IED 6.5 m - 100 m	Amplitude error		max 0.1%	Constant
	Phase dis. Error		max 0.5°	Constant
Frequency response 50Hz - 1500Hz	Amplitude error	Protection (50 - 300Hz)	0.5% ... 1.7%	All cables
		Metering (50 - 1500Hz)	0.5% ... 1.6%	6.5 m cable only
	Phase dis. Error	Protection (50 - 300Hz)	-90°... -92°	All cables
		Metering (50 - 1500Hz)	-90°... -92°	6.5 m cable only

Resistive divider

Accuracy is acceptable for the application in MV networks and switchgears. Accuracy of resistive divider is not dependent on temperature. Contribution errors of amplitude and phase displacement errors as function of the temperature can be considered as negligible for the applications in MV networks and switchgears. Cable length between resistive divider and IED is also not limiting factor in MV applications. Cable up to 100m generate small measuring errors of amplitude and phase displacement, both have constant pattern. Depending on application, these errors can be offset by setting correction factor in IED. Accurate measurement of high harmonics by resistive divider has limits of the cable length between resistive divider and measuring electronic. Measurements showed that cable length between resistive divider and IED shall no exceed 20 m for protection purposes and 6.5 m for power quality purposes. In this case measuring error of amplitude

and phase displacement stays within the values acceptable in MV applications. Results are summarized in Tab.5-10.

Tab. 5-10 : Resistive divider meas. errors influence by external fac. (App. 5, 6, 7, 8)

		Resistive divider		
		Dependency	Pattern of the error	
Temperature -40°C - 115°C	Amplitude error	0.15% ... 0.42%	Constant	
	Phase dis. Error	0° ..0.14°	Constant	
Distance to IED 6.5 m - 100 m	Amplitude error	max 0.6%	Constant	
	Phase dis. Error	max 4°	Constant	
Frequency response 50Hz - 1500Hz	Amplitude error	Protection (50 - 300Hz)	-0.5% ... -1%	Cable max. 20m
		Metering (50 - 1500Hz)	-0.5% ... -1%	Cable max. 6.5 m
	Phase dis. Error	Protection (50 - 300Hz)	0° ... -5°	Cable max. 20m
		Metering (50 - 1500Hz)	0° ... -5°	Cable max. 6.5 m

Capacitive divider

Accuracy dependency on external factors, especially temperature makes application of capacitive divider in MV networks questionable. It could be used in application where ambient temperature shall not exceed 40°C. In this case accuracy error of amplitude and phase displacement are within the limits acceptable in MV applications and both have contact pattern which allows to set correction factors in IED and offset measurement error close to zero. Capacitive divider shows excellent performance as far as the accurate high harmonics measurement is concerned. Capacitive divider does not generate any measurement errors of amplitude and phase displacement up to 10 kHz. Results are summarized in Tab.5-11.

Tab. 5-11 : Capacitive divider meas. errors influence by external fac. (App. 5, 6, 7, 8)

		Capacitive divider		
		Dependency	Pattern of the error	
Temperature -40°C - 115°C	Amplitude error	-3 %... 42.39 %	Non linear	
	Phase dis. Error	4° ... 7°	Non linear	
Distance to IED 6.5 m - 100 m	Amplitude error	Not tested	Not tested	
	Phase dis. Error	Not tested	Not tested	
Frequency response 50Hz - 1500Hz	Amplitude error (50Hz - 1500Hz)	0.2%...-0.8%	Constant	
	Phase dis. Error (50Hz - 1500Hz)	0°	Constant	

Further part of this thesis is focused to application of sensors in MV switchgears. Due to the fact that higher operating temperature range is required in MV switchgear applications capacitive divider is not further considered for the purpose of this thesis. This is also the reason why impact of the long cables on voltage measurement by capacitive divider has not been done.

6 CALCULATION OF RESIDUAL CURRENT, APPLICATION OF ROGOWSKI COIL

6.1 General arrangements and rationale of the measurement

Chapter 5 of this thesis explains accuracy of the current and voltage measurement of the Rogowski coil and voltage dividers. Use of sensors can help to develop new approaches and practices in MV applications and switchgears in particular. Thanks to linear characteristics, measuring dynamic range and very accurate measurements by sensors use, protection functions algorithms can be less complicated and we can achieve simplification of the protection systems, better sensitivity and selectivity. In this chapter, example of how the use of the Rogowski coil can change approach and can simplify application of earth-fault protection function is shown.

Current practice in MV application is to use core balance current transformer, which is mounted around all three line cables as shown on Fig.6-1. This transformer measures vector sum of magnetic fields generated by currents which flows in all three phases. In steady-state conditions sum is zero and therefore value of residual current on secondary terminals of the core balance current transformer is zero. In case of unbalance between phase currents caused by earth-faults, an unbalanced magnetic field generates proportional residual current at secondary terminals. Theoretically, the same phenomena could be applied on Rogowski coil, however it would be very expensive to produce Rogowski coil with diameters of several tens of cm. The idea of calculating residual current in IED from measured line currents is of course not new, however experience from residual current calculation in IED by measurement of line currents with Rogowski coils is missing. Especially answers on accuracy of such a measurement across whole metering range is demonstrated in this chapter.

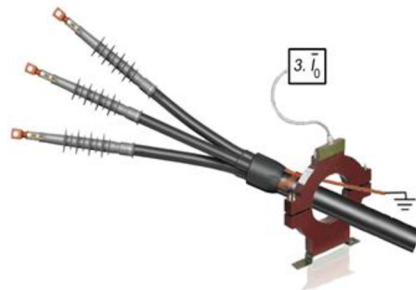

Fig. 6-1 : Example of core balance transformer

Residual current is calculated from phase currents measurements by their vectors sum. In ideally balanced system $I_0 = 0$, Fig.6-2. Residual current unbalanced can be generated by various factors and phenomena. This thesis explains possible impacts of the residual current generated by inaccuracy of the Rogowski coil.

$$\vec{I}_{L1} + \vec{I}_{L2} + \vec{I}_{L3} = \vec{I}_0$$

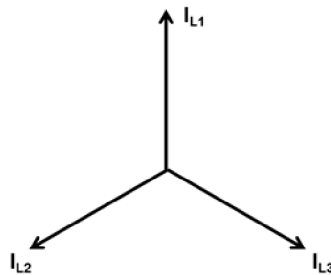

Fig. 6-2 : Ideal distribution of the line to ground currents in the 3-phase system

Phase current measurement is always affected by measurement accuracy in certain extend, it has impact also to accuracy of residual current calculation. Due to the phase currents measurement inaccuracy, the apparent residual current $I_{0(ap)}$ is always generated, example can be seen in Fig.6-3. Generation of the apparent residual current in undesirable however unavoidable.

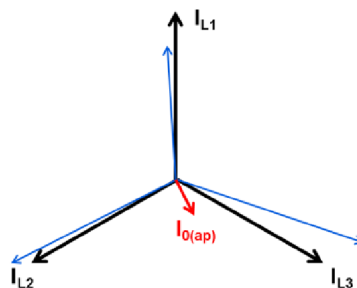

Fig. 6-3 : Apparent residual current $I_{0(ap)}$ in the 3-phase system and

It is important to understand amplitude value of the $I_{0(ap)}$ over the whole measuring range which shall lead us to conclusions whether accuracy of residual current calculation in IED can influence overall accuracy of earth fault protection in any type of networks. Fig.6-4 illustrates example of possible relations between real residual current $I_{0(r)}$ and apparent residual current $I_{0(ap)}$. Real residual current can be described according Eq.6-1.

$$I_{0(r)} = I_0 + I_{0(ap)} \quad (Eq.6-1)$$

It is important to understand whether the $I_{0(ap)}$ can reach such a value that can generate false pick up of the earth fault protection.

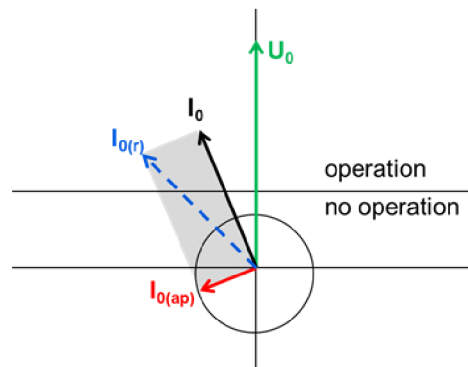

Fig. 6-4 : Real residual current I_0 and apparent residual current $I_{0(ap)}$ relation

It is also important to understand phase displacement between real residual current I_0 and apparent residual current $I_{0(ap)}$, since it might have negative impact on proper detection of earth fault current value and direction in the system. Example of the phase displacement between I_0 and $I_{0(ap)}$ can be seen in Fig.6-5.

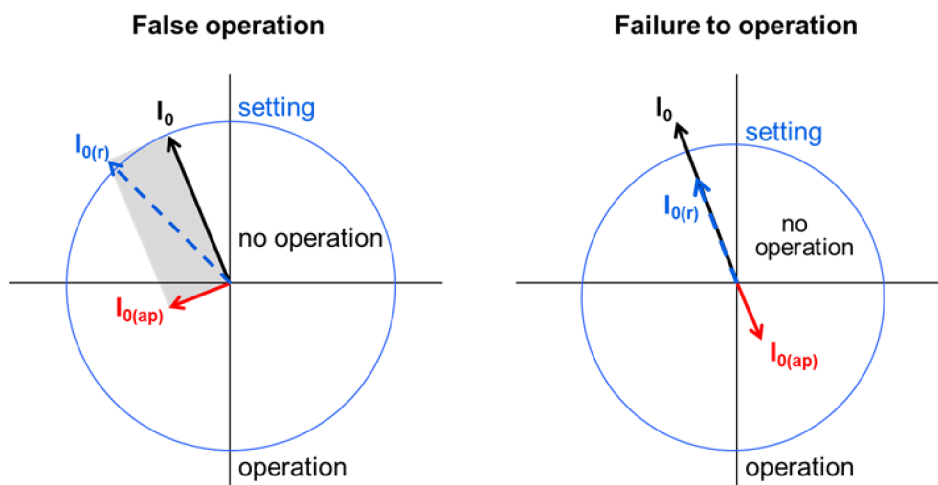

Fig. 6-5 : Phase disp. - real residual current I_0 and apparent residual current $I_{0(ap)}$

For the purpose of residual current calculation by IED from the line currents measured by Rogowski coil, ABB REF 615 IED was used with ABB KEVCD 24 AE3 electronic instrument transformers. Specification of sensors can be found in Appendix 1. Six tests were done in order to verify impact of apparent residual current to an overall accuracy of residual current calculations by IED.

- 1) Laboratory testing – Static tests
 - a. Stability of the system characteristic with two different nominal current. The target is to compare sensitivity of the REF 615 current deviation depending on primary nominal current settings.
 - b. Earth fault protection tested in 1-phase system. The target of the measurement is to find threshold values of the apparent residual current generated by sensors systems inaccuracy. Threshold values when asymmetry is detected by the REF 615 and asymmetry which is not yet detected by the REF 615.
 - c. Earth fault protection tested in 3-phase system. The target is to verify if residual apparent current naturally created by the different accuracy of the sensors in each phase does not influence proper functionality of the earth fault protection function by means of fault pick up or trip.
- 2) Testing on primary network model – Dynamic tests
 - a. Stability test on inrush current in the network caused by the power transformer. The target of the measurement was to verify possible impact of the generated current unbalanced in the system caused by power transformer inrush current.
 - b. Earth fault in system with isolated neutral. The target was to verify sensitivity of earth fault protection with virtually calculated residual current in systems with isolated neutral.
 - c. Earth fault in system with high impedance neutral. The target was to verify sensitivity of earth fault protection with virtually calculated residual current in systems with high impedance neutral.

6.2 Parameters of the laboratory tests

As explained in chapter 5 it is important to define amplitude and phase correction factors of particular sensors in order to achieve the best results of the measurements. Tab. 6.1 defines correction factors of the sensors used during in measurement. This values were defined in REF 615 IED in order to offset measuring errors close to zero.

Tab. 6-1 : Correction factors of used Rogowski coils

Sensor serial #	Voltage correction factors		Current correction factors	
	amplitude c.f.	phase c.f.	amplitude c.f.	phase c.f.
1VLT5411010801	1.001	+0.067 °	0.9925	+0.067 °
1VLT5411010802	1.0014	+0.112 °	0.9926	+0.065 °
1VLT5411010803	1.0018	+0.292 °	0.9907	+0.070 °

In order to verify stability of the system and sensitivity of the REF 615 residual current calculation two measurements with two different settings of nominal reference current were done at 80 A and 1000 A.

For the verification of the earth fault protection in one phase system primary current was increased in steps. REF 615 earth fault setting was set to most sensitive level and verification if the value of apparent residual current reached the minimum pick up residual current settings in REF 615 was done. The same was repeated for the three phase system.

6.3 Results and conclusions from the laboratory tests

All details of the tests and results are documented in Appendix 9.

The conclusion from static tests performed is that sensors enable more accurate signal transformation comparing with conventional instrument transformers, particularly for very low and very high primary currents. Using of sensors enable setting of earth fault protection for 1% of primary rated current 40 A for low primary currents and 3% of primary rated current 40 A for high primary currents. The measurement with high primary current verified the correct behavior of sensors and their linear non-saturated characteristic.

- 1) **For nominal current I_{pn} 80 A = rated primary current of sensor I_{pr} 80 A**
It was measured currents from 5% up to 120% of $I_{pr}=80$ A where the nominal current parameter I_{pn} was set to 80 A as well. Mean root-square error of value read from REF615 HMI (in the range 0.060-0.136 A) was slightly higher than mean root-square error of injected current (in the range 0.050-0.098 A).
- 2) **For nominal current I_{pn} 1000 A \neq rated primary current of sensor I_{pr} 80 A**
It was measured currents from 5% up to 120% of $I_{pr}=80$ A where the nominal current parameter I_{pn} was set to 1000 A. Mean root-square error of value read from REF615 HMI (in the range 0.110-0.544 A) was higher than mean root-square error of injected current (in the range 0.060-0.080 A)

It is recommended to use the same settings for both parameters – the Nominal current as well as the Primary

Conclusions of earth fault protection behavior in one phase system showed positive results. Fig.6-6 shows threshold values when asymmetry (I_{0Op} – Operative state of the earth fault protection) is detected by the REF 615 and asymmetry (I_{0Ino} – Inoperative state of the earth fault protection) which is not yet detected by the REF 615. Results shows that asymmetrical apparent current as seen by REF 615 has very small values. This values are below typical pick-up values of earth-fault protection so the risk of false operating of the earth-fault protection created by apparent residual current is neglected.

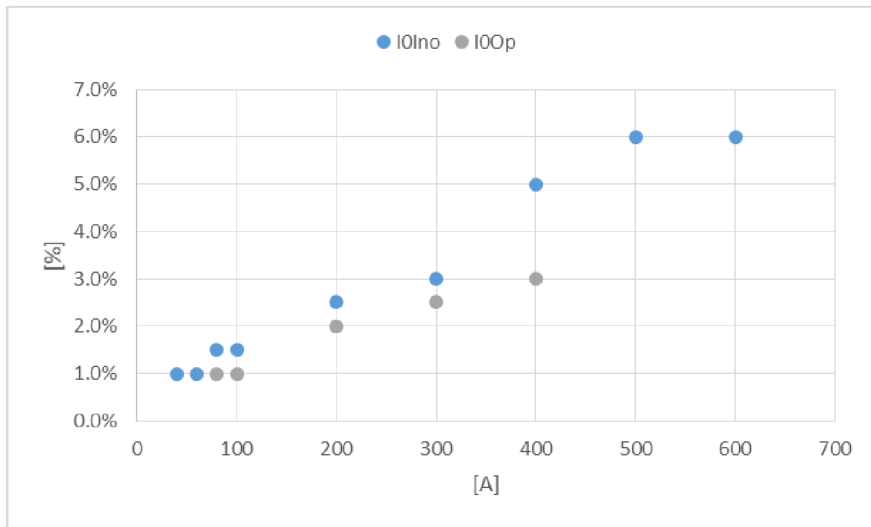

Fig. 6-6 : Earth fault protection for nominal current $I_{pn} = 40$ A, REF 615

Conclusions of earth fault protection behavior in three phase system showed also very positive results. $I_{o(ap)}$ created as results of unbalanced current between phases due to the different accuracy of the sensors in each phase increases with measured current I_p . $I_{o(ap)}$ expresses as percentage value of measured current I_p has exponential character as seen from Fig.6-7. $I_{o(ap)}$ did not reached such value which would initiate pick up stage of REF 615 protection even the settings ware set at most sensitive level. Gap between minimum pick up residual current and residual apparent current gives a sufficient safety margin that allows to make conclusion that calculation of the residual current by the IED for earth fault protection from the line currents measured by Rogowski coil will always work in isolated and directly earthed neutral. Reliable application of residual current calculation by IED in MV networks where neutral is earthed through Petersson coil (compensated networks) requires to make field measurements.

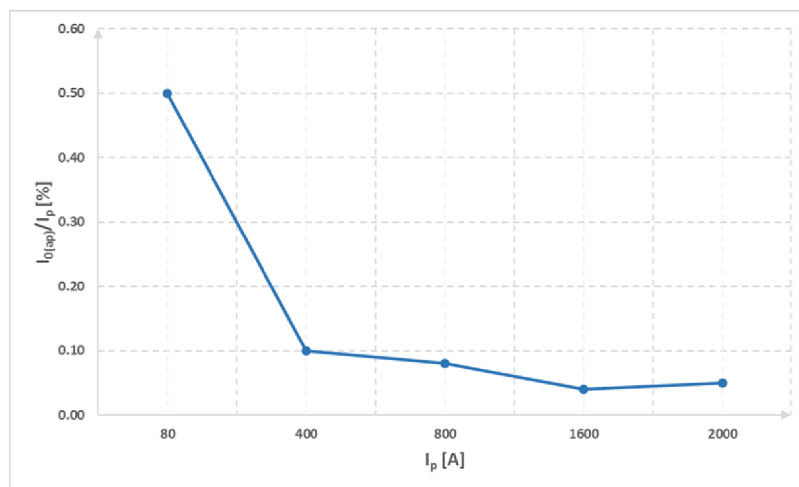

Fig. 6-7 : Characteristics of $I_{o(ap)}/I_p = f(I_p)$ [%]

6.4 Results and conclusions from testing on primary network model

Additional tests were made on top of the laboratory testing in order to verify proper behavior of the earth fault protection function with virtual residual current calculation in IED. Focus was given on specific situations which may appear in some MV networks such as stability test on inrush current, intermitted earth faults, different earth fault resistances. Measurements are not described with high degree of the details but they can be provided upon request. Overview of the results underlines stabilized measurements of the line currents measured by the Rogowski coil and consequential virtual calculation of the residual current in IED for further processing in IED with focus on proper behavior of the earth fault protection.

Measurements were done on primary network model simulating different type of networks and faults.

6.4.1 Stability test on inrush current in the network caused by the power transformer

Fig.6-8 describes block diagram of the measurements. The target of the measurement was to verify possible impact of the generated current unbalanced in the system caused by power transformer inrush current. Current unbalance in the system creates virtual residual current which is transferred to REF 615 by the calculation of virtual residual current from the line current measurements by the Rogowski coil. Directional earth fault protection cannot trip in this case. Twenty-five tests were done with different lengths of the cables between Rogowski coil and REF 615. During all 25 different inrush conditions tests no false operation of the directional earth fault protection was registered.

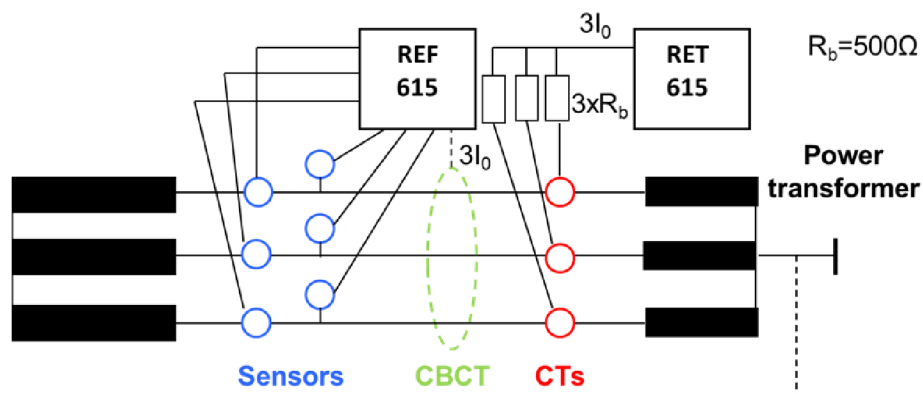

Fig. 6-8 : Block diagram of earth fault protection stability on inrush current

6.4.2 Earth fault in system with isolated neutral

Testing was done according schematic diagram on the Fig.6-9.

First test was made by simulating solid earth fault of the phase R with the wire were directly connected to earth potential. The most sensitive settings of directional earth fault protection were applied. Six different tests were made where correct detection of fault direction and opposite polarity of current inputs were verified. Earth fault current values were app. 1.6 A. In all cases directional earth fault protection element of the REF 615 with virtual residual current calculation from line currents measured by Rogowski coil behaved according expectations.

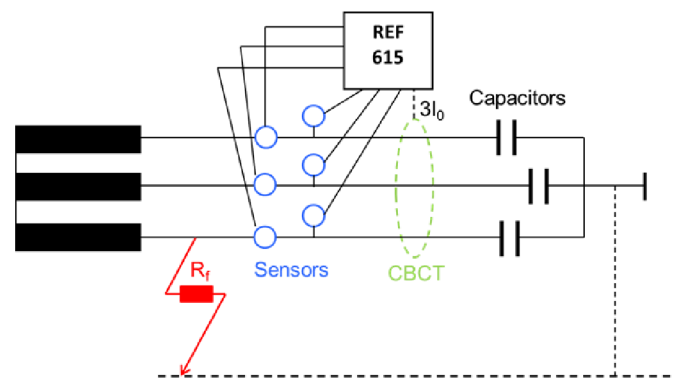

Fig. 6-9 : Block diagram – simulation of MV isolated neutral network

Second test was made by simulating of different fault resistance connected between phase R and earth potential. Values of $R_f = 1.13 \Omega$, 50Ω , 100Ω , 114Ω and 115Ω were simulated. Earth faults currents between 1.6 A and 0.7 A were measured. Simulation of earth fault resistance higher than 115Ω showed unstable behavior of the earth fault protection. This can be also explained as the limit of the most sensitive pick up value settings. In other words natural unbalanced of residual current created by sensors themselves can create false trip of the earth fault protection function.

Third test when simulating MV system with isolated neutral intermittent earth fault. Phase R was connected to earth potential through rheostats (5.4Ω and 250Ω). Intermittent earth faults were simulated by moving of pin on opposite side of rheostats – small arcs were created („welding“). Eleven different tests were done. Comparisons of the residual current measured directly by core balance transformer and the residual current virtually calculated by IED from the line currents measured by the Rogowski coil were made. From the disturbance records made during measurements no deviations between measured and calculated residual current were found. Example of the disturbance record can be

seen from the Fig. 6-10. Channels descriptions for Fig. 6.10 are 1 – I_{L1} ; 2 – I_{L2} ; 3 – I_{L3} ; 4 – $I_{0(\text{measured})}$; 8 – $I_{0(\text{calculated in IED})}$

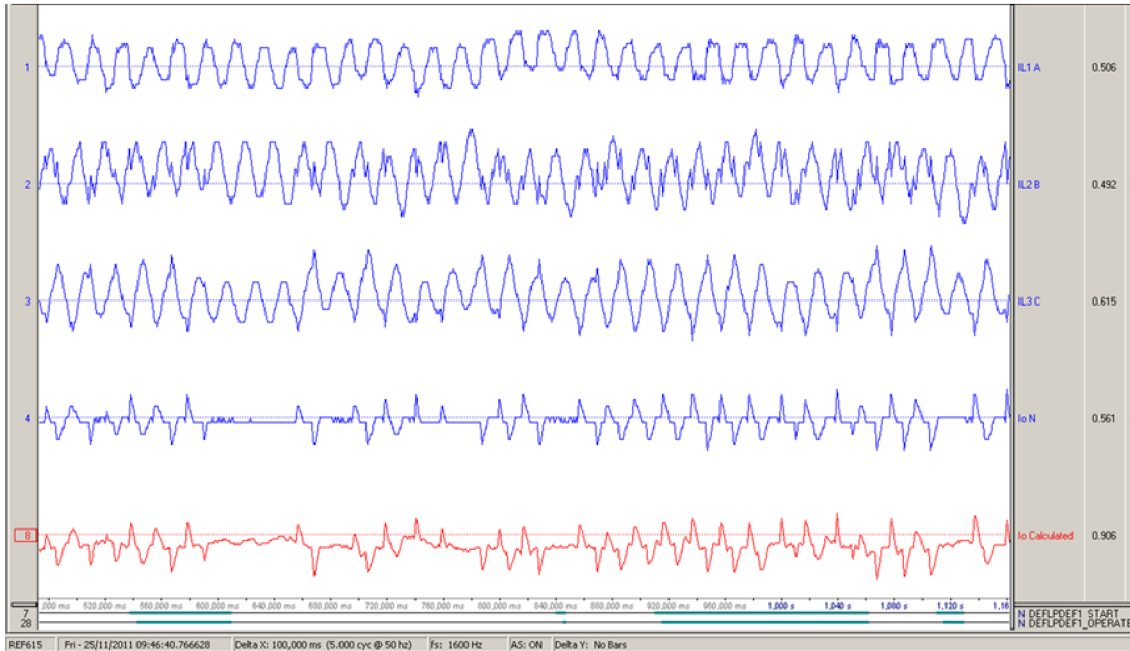

Fig. 6-10 : Intermittent earth fault DR - MV network with isolated neutral

6.4.3 Earth fault in system with high impedance neutral

Testing was done according schematic diagram in the Fig.6-11.

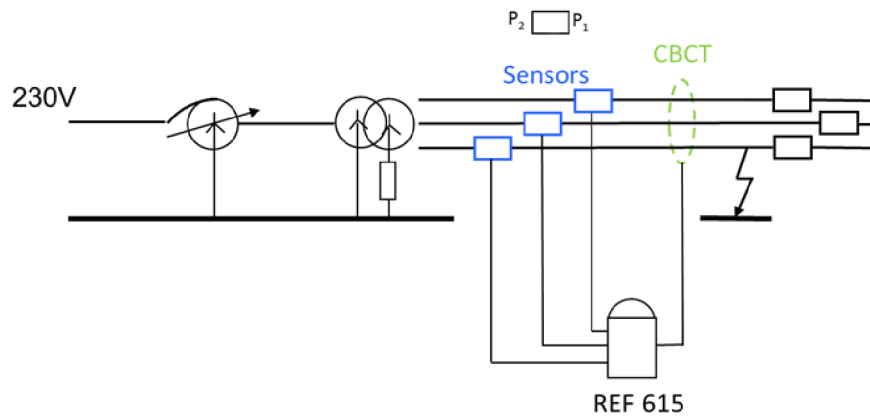

Fig. 6-11 : Block diagram – simulation of MV high impedance neutral network

Three sample tests were done with most sensitive settings of the earth fault protection function as mentioned above. Resistors of 150 Ω and 200 Ω were used for the purpose of the fault simulation between phase R and earth. Earth faults current of 1.5 A for the 150 Ω resistor and 0.6 A for the 200 Ω resistor were measured. In all case earth fault protection function behaved as expected with no signs of false earth fault detection.

6.5 Overall collusions of the Rogowski coil application for earth fault protection

Saturation phenomena of the instrument transformers is well-known constrains that must be taken into account when specifying required parameters of the instrument transformers as a result of the short circuit selectivity study for the particular application. All measurements as described in chapter 4 and 5 clearly show that beside well known linear characteristics of the sensors also accuracy of them measurement across complete dynamic range has positive effect on protection functions behavior. Protection functions algorithms of all IEDs counts with instrument transformer saturation phenomena. It can be concluded that use of sensors and full utilization of their measurement characteristics would require new approach what comes to processing of the measuring signal in IED and its further use for protection functions. Algorithms of the protection function would need to be also reconsidered in order to fully utilize all positive attributes of the current and voltage measurement by the Rogowski coil and voltage divider. The subject of this thesis was not to investigate how the IED architecture could be changed however above assumptions are confirmed by the investigation of earth fault protection behavior with virtual calculation of the residual current in IED from line to neutral currents measured by the Rogowski coil. Detailed measurements were done in order to understand behavior of complete system Rogowski Coil – Cable – IED.

Stability measurement characteristics showed that settings of the nominal value in IED influences deviation of the measurement as seen by the IED in comparison to real current in the system. The lower the nominal value current settings the smaller the deviation is seen.

Examination of the earth fault protection function tested in one phase system showed that naturally created apparent residual current as result of the Rogowski coil inaccuracy, increases with the supplied current, however its values represents such a small fraction of the supplied current that chance of earth fault protection false behavior is very unlike.

Testing of the earth fault protection in three phase system showed that apparent residual current created from the contributions of the Rogowski coils inaccuracy in all three phases increases with supplied primary current, however its value expressed as percentage of the supplied primary current has exponential character. This is very important conclusion, which confirms that false behavior of the earth fault protection due to the natural current

unbalanced created by the Rogowski coils is very unlike. Values of the apparent residual current are well below minimum pick up residual currents values of the REF 615 earth fault protection.

When instrument transformers are used, it is generally recommended to not use residual current calculation if there is chance of having earth fault current lower than 10% of the nominal current. Core balance transformers are commonly used in such a cases. Type of the MV network from the neutral grounding principle must be considered as well.

Measurements of the earth fault protection behavior with the line to ground current measurements by the Rogowski coil and consequential calculation of the virtual residual current by IED, showed that above mentioned generally used rules for instrument transformers are not applicable when measuring current by the Rogowski coil. New rules can be recommended when calculating residual current in IED from the line to ground current measurements by the Rogowski coil.

- MV feeders up to $I_r = 3150 \text{ A}$ and $I_k'' = 31.5 \text{ kA}$. Earth fault currents above 1% of the nominal current can be safely calculated by the IED from the line to ground currents measured by the Rogowski coil
- MV feeders up to $I_r = 4000 \text{ A}$ and $I_k'' = 50 \text{ kA}$. Earth fault currents above 3% of the nominal current can be safely calculated by the IED from the line to ground currents measured by the Rogowski coil

Above conclusions are applicable for the Rogowski coil ratio settings in the IED 40A / 150 mV. Voltage measuring range of the IED analog input card must be verified when full current dynamic range (up to I_k'') is required to be measured.

Additional tests on primary network model showed satisfactory stability of the earth fault protection behavior when calculating residual current from the line to ground currents measured by Rogowski coil. No false trips were registered when simulating

- Power transformer inrush current in the system
- Different resistance of the fault currents in unearthed neutral networks
- Different resistance of the fault currents in high impedance neutral grounded networks

Conclusion of the universal earth fault protection with no need to consider core balance transformer can be made for following networks

- Unearthed neutral MV networks
- Low impedance neutral earthed MV networks

Above conclusion assumes residual current virtual calculation from the line to ground currents measured by the Rogowski coil can be made.

High impedance neutral earthed networks would require further field investigations and tests which is not a subject of this thesis. Results of the measurements and tests presented in Chapter 5 creates high confidence that above conclusion can be extended also for this type of MV network from the neutral earthing principle stand point.

7 NEW ARCHITECTURE OF MV AIR INSULATED SWITCHGEAR AND SUBSTATION

7.1 Definition of the gap

The major technical challenge when considering use of the sensors in MV applications and especially in MV switchgears is simple and efficient distribution of the voltage measurement within substation. As documented in chapter 4, cable length between voltage sensor and IED is not an issue that limits application. In case of voltage transformer application, character of the voltage transformer output signal simple allows to distribute voltage by use of hardwiring within substation. Each IED voltage analog input channel is connected in parallel to voltage transformer where the desired measurement needs to be taken from. Available power output of the voltage transformer is the only limiting factor how many IEDs can be connected with particular voltage transformer in parallel. Simplified voltage measurement distribution within substation when voltage transformers are used can be seen from Fig.7-1.

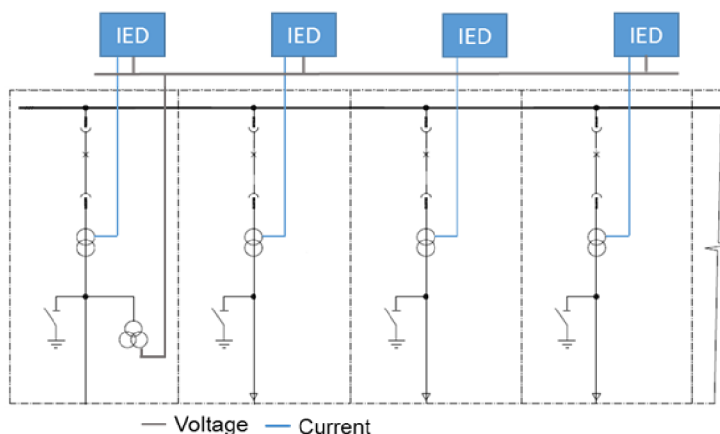

Fig. 7-1 : Block diagram - voltage and current distr. with instrument transformers

Current measurement distribution within or outside of the substation does not represent difference between application of the current transformers and the Rogowski coil. Current measurement is connected in series between current measurement source and analog input of an IED. Limiting factor might be the only distance between measuring device and the IED. Relations of cable length between the Rogowski coil and IED is explained in the chapter 4. The best way how to distribute measured values within substation is to digitalize measurements as close as possible to measurement point and transfer sampled measured values over high speed communication bus deployed within substation. There are many techniques and standards for measurements digitalization as well as high number of communication systems architecture that can be theoretically used. This chapter identifies the optimised architecture of the MV air insulate switchgears with

sensors and measurement digitalization. IEC 61850 was chosen communication standard for the purpose of this thesis.

7.2 Architecture of the MV air insulated switchgear with sensors and process bus.

Most of the air insulated switchgears are single bus bar systems with two sections where each section includes one incoming feeder and several outgoing feeders. Both sections are horizontally separated with bus coupler element which is typically operated with normally open circuit breaker. Typical single line diagram of such a substation configuration is on Fig.7-2.

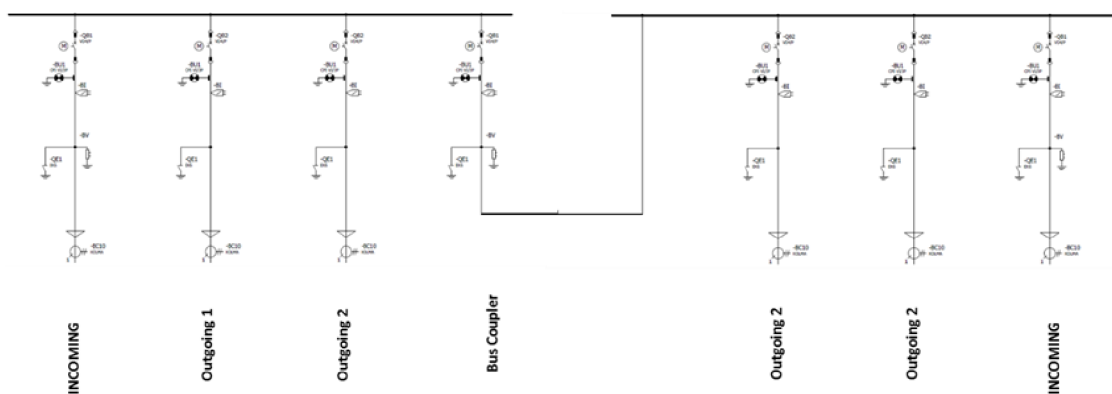

Fig. 7-2 : Typical substation configuration for MV air insulated switchgears

Each circuit breaker feeder includes an IED. The most elementary task of the IED is to protect particular feeder and load against fault situation and by breaking of the energy by tripping of the circuit breaker limit potential mechanical or thermal damages as consequence of the potential fault preferably to zero level. Measurements of currents and voltages are essential input data for the protection algorithms of IEDs. Majority of the protection functions requires following measurements for their principles of work

- Line to ground currents
- Incoming feeders line to ground voltages
- Bus bar line to ground voltages
- Residual current
- Residual voltage

Certain protection functions such as differential protection, synchrocheck requires additional or different sets of measurements as input data. This thesis is focused on MV air insulated switchgear architecture limited to use of measurements mentioned above

only. Further considerations on what IEC 61850 can and cannot offer to traditional protection schemes is in [19].

Architecture of the substation where all above mentioned measurements are available to any IED at any time would be very beneficial to use any protection function independently on substation hardware configuration. Assumption of availability of all needed measuring data can decouple configuration and engineering of the measuring hardware from protection application in particular IEDs. The basic precondition to develop such architecture is to use Rogowski coil and voltage divider for current and voltage measurements. This decoupling can create many advantages what comes to engineering activities through entire life cycle of the MV air insulated switchgear.

- Linearity and accuracy of the current measurement by Rogowski coil does not require engineering of its parameters as result of the short circuit selectivity study
- Decision on protection scheme to be finally used in particular feeder can be done any time during project execution
- Additional protection function can be included to protection scheme once switchgear is under operation without need to re-engineer measuring apparatus and changes in substation wiring
- Change of the rated current level during life cycle does not require changes of the current measuring apparatus

Bottom up approach was selected to define new architecture of the MV air insulated switchgear application which would meet above idea of decoupling measuring apparatus specification and engineering from protection application.

- 1) Definition of the standard feeders
- 2) Overall example of the single line diagram and communication bus
- 3) Calculation of communication bandwidth
- 4) Selection of communication architecture and redundancy principle

7.2.1 First step – definition of the standard feeders

Basic elements of every substation are feeders. Typical feeders must be defined in such way that they can all together measure all above mentioned voltage and current measurements. Due to the short distances within one feeder all data between switchgear apparatuses and IED are hardwired and data transmission is always in analog format. IED in every feeder acts as merging unit (MU) in order to publish or subscribe any digital binary signals and sampled measured values needed to be shared within substation.

Incoming feeder with voltage measurement is the first typical feeder and its standard single line diagram is in the Fig.7-3

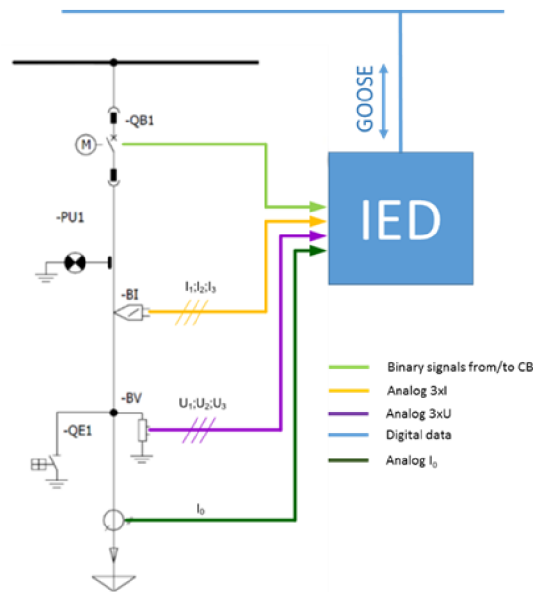

Fig. 7-3 : Typical incoming feeder with voltage measurement

This feeder is intended to be used to bring energy from upper level system to the substation for each section in the substation configuration. IED has all necessary measurements available. Line currents are measured by the Rogowski coils. Incoming feeder voltages are measured by resistive voltage dividers. Residual voltage is virtually calculated in IED and residual current can be either measured or calculated virtually in IED. IED publishes and subscribes binary substation events (GOOSE messages) for substation level control, blocking and interlocking purposes.

Outgoing feeder with busbar voltage measurement is the second typical feeder and its standard single line diagram is in the Fig.6.5

This feeder application has to deliver energy through cables to downstream systems or supply energy to motors. IED has all necessary measurements available. Line currents are measured by the Rogowski coils. Bus bar voltages are measured by resistive voltage dividers. Residual voltage is virtually calculated in IED and residual current can be either measured or calculated virtually in IED. IED publishes and subscribes binary substation events (GOOSE messages) for substation level control, blocking and interlocking purposes. Additional important function of the IED is to publish SMV of the bus bar voltage for other outgoings feeders in the substation.

The third typical feeder needed to build substation is bus coupler. This type of feeder is used to separate sections of the substation with two independent incoming energy sources. Bus coupler is operated with normally open circuit breaker. Additional important function of the bus coupler is to increase availability of the energy in case of one of the incoming feeders is out of service and there is need to keep energy delivery continuity in

the section where incoming feeder is out of service. Single line diagram of standard configuration of bus couples is in the Fig.7-5.

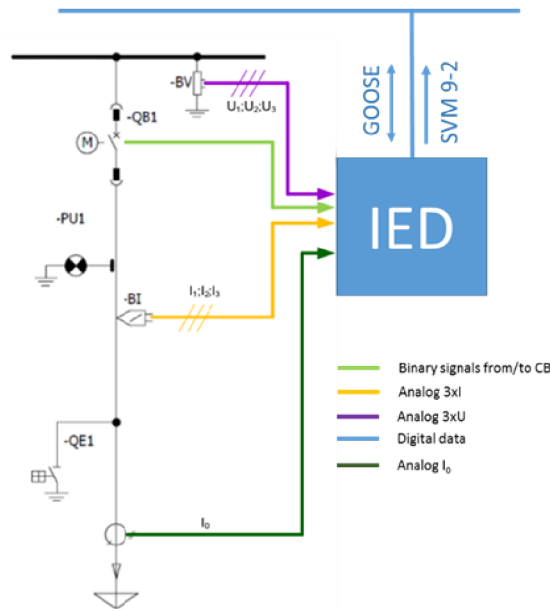

Fig. 7-4 : Typical outgoing feeder with busbar voltage measurement

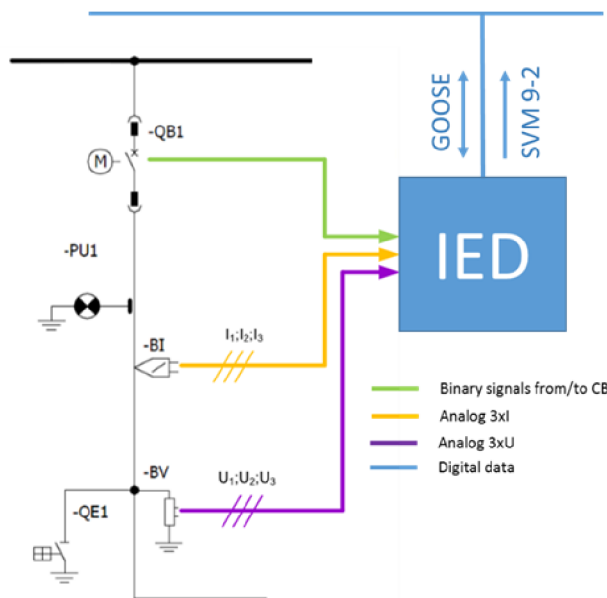

Fig. 7-5 : Typical bus coupler feeder with busbar voltage measurement

IED has all necessary measurements available. Line currents are measured by the Rogowski coils. Bus bar voltages are measured by resistive voltage dividers. Residual voltage is virtually calculated in IED. IED publishes and subscribes binary substation events (GOOSE messages) for substation level control, blocking and interlocking purposes. Additional important function of the IED is to publish SMV of the bus bar voltage for other outgoings feeders in the substation.

The fourth and last typical feeder is outgoing feeder. Single line diagram of this feeder is on the Fig.7-6.

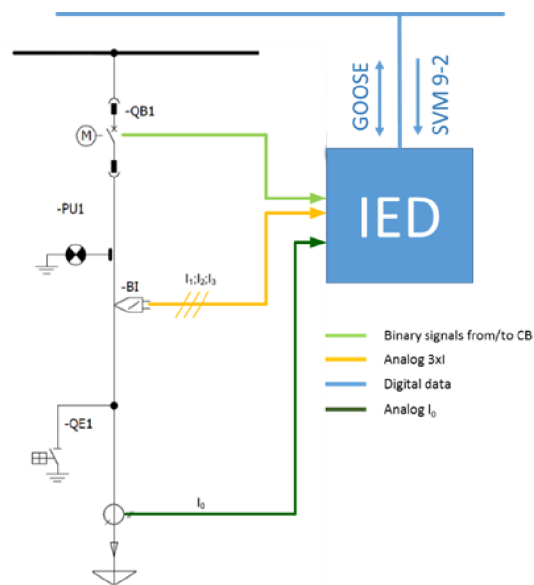

Fig. 7-6 : Typical outgoing feeder

This feeder application is to deliver energy through cables to downstream systems or supply energy to motors. IED has all necessary measurements available. Line currents are measured by the Rogowski coils. Busbar voltages are subscribed from communication bus. Depending on protection scheme needs, either voltages from section measured and published by outgoing feeder with voltage measurement, ref. to Fig. 7.7) or from section B (measured and published by bus coupler with voltage measurement, ref. to Fig. 7.7). Residual voltage is virtually calculated in IED and residual current can be either measured or calculated virtually in IED. IED publishes and subscribes binary substation events (GOOSE messages) for substation level control, blocking and interlocking purposes.

7.2.2 Second step - Overall example of the single line diagram and communication bus

Fig.7.7 shows an example how the typical substation can be built from the typical feeders described above. Combination of current measurements by Rogowski coil and voltage measurements by voltage divider with digital bus where substation events and sampled measured values are shared allows to decouple engineering of measuring hardware from protection applications. All feeders have all important measurements available independent on protection schemes needed for particular feeder applications. Line to ground currents are always measured in each feeder separately for the protection purposes of each and every IED. Incoming feeders use resistive dividers connected to cables and provide voltage measurements for IEDs in incoming feeders. Outgoing feeders protection schemes may need to use busbar voltage measurements. For this purpose one outgoing feeder in section A (Fig. 7.7) includes resistive voltage dividers connected to bus bar system in section A and bus coupler equipped with resistive voltage dividers connected bus bar system in section B (Fig. 7.7). IEDs in this feeders beside potential use of measured voltage for their protection schemes publish voltage sampled measured data to digital communication. All other IEDs either in section A or B can subscribe this digital voltage measurements for the purpose of the particular protection scheme. Residual voltages are virtually calculated in every feeder and residual currents can be measured in every feeder directly from core balance transformer or virtually calculated. Finally binary substation events are also shared among all feeders for the purpose of substation control, blocking or interlocking logics.

APPLICATION OF SENSORS AND DIGITALIZATION BASED ON IEC 61850 IN MEDIUM VOLTAGE NETWORKS AND SWITCHGEARS

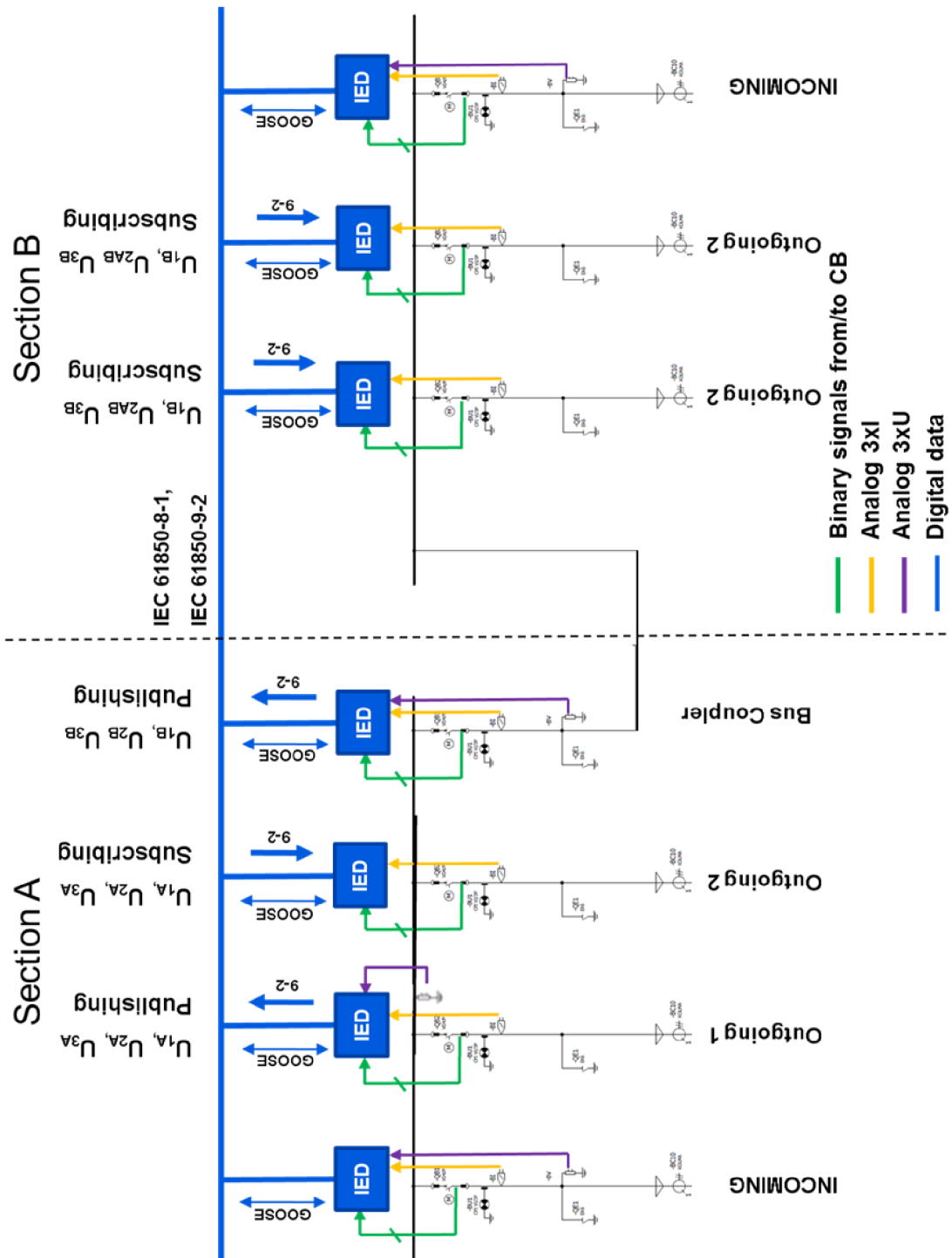

Fig. 7-7 : Typical MV Substation architecture with sensors and digitalization [11]

7.2.3 Third step - Calculation of communication bandwidth

As mentioned in first part of this chapter IEC 61850 uses Ethernet as physical communication layer and TCP/IP as communication protocol. It is very important to understand available communication bandwidth of Ethernet, so the sampled measured values can be transferred without any issues or bottlenecks in communication. Basic assumption is to 100 Mb/s Ethernet. IEC 61850-9-2 LE [7] (light edition) specifically designed for MV applications defines two distinct sampling rates.

- 80 samples per nominal period for protection applications; one set of samples is sent immediately in one SMV message
- 256 samples per nominal period for metering applications; eight sets of samples are sent in one SMV message

Since metering functionality is managed by other devices than IEDs, 80 samples per nominal period for protection applications is considered for the purpose of this thesis.

Sampling rates for 80 samples per cycle

- $f_1 = 80 \times 50 \text{ Hz} = 4 \text{ kHz} \Rightarrow T = \frac{1}{4 \text{ kHz}} = 250 \text{ } \mu\text{s}$ (50 Hz system)
- $f_2 = 80 \times 60 \text{ Hz} = 4.8 \text{ kHz} \Rightarrow T = \frac{1}{4.8 \text{ kHz}} = 208 \text{ } \mu\text{s}$ (60 Hz system)

Data volume broadcasted by one IED

- Each IED SMV frame has 160B = 1280b
- $50 \text{ Hz} \times 80 \times 1280 \text{ b} = 5.12 \text{ Mb/s}$ (50 Hz system)
- $60 \text{ Hz} \times 80 \times 1280 \text{ b} = 6.15 \text{ Mb/s}$ (60 Hz system)

Communication infrastructure used for publishing of SMV is also use for the transfer of the GOOSE messages among IEDs. Therefore it is important to understand, what is data size of GOOSE message from one IED.

Assumptions:

- Heartbeat event cycle maximum time [24 part 18.2.2.5] = 1s => one message/s
- One substation event = four messages/s
- Two DataSets where 10 signals/dates
- Each GOOSE frame has 200B = 1600b

Approximate data size volume per IED when broadcasting GOOSE frames (burst conditions)

$$4 \frac{\text{messages}}{\text{s}} \times 2 \times 10 \times 1600 \text{ b} = 0.128 \text{ Mb/s}$$

Above calculations shows the fact that both GOOSE messaging broadcast and SVM publish takes considerable size of the total communication capacity so both must seriously take into account when designing MV switchgear with process bus.

General recommendation is to reserve 50 Mb/s it means half of the available 100 Mb/s Ethernet capacity for broadcasting of the substation events so called MMS telegrams between IEDs and SCADA system and GOOSE messages – substation events shared among IEDs for control, blocking and interlocking purposes. Second half of the total available 100 Mb/s Ethernet capacity can be used for SMV data sharing.

Considering of all above calculations and constrains following conclusions can be made what comes to available capacity of 100 Mb/s Ethernet for process bus applications in MV switchgears.

- Single and PRP redundant network architecture
 - Maximum amount of SMV publishers for 50 Hz system = 9
 - $(\frac{100 Mb}{s} \div 2) \div \frac{5.12 Mb}{s} = 9.76$
 - Maximum amount of SVM publishers for 60 Hz system = 8
 - $(\frac{100 Mb}{s} \div 2) \div \frac{6.15 Mb}{s} = 8.13$
 - Available communication capacity considering two SMV publishers
 - SMV = 12.3 Mb/s
 - GOOSE + MMS = 87.7 Mb/s
- HSR redundant network architecture (principle of the HSR redundancy requires parallel data broadcasting it means half of the 100Mb/s Ethernet can be considered)
 - Maximum amount of SMV publishers for 50 Hz system = 4
 - $(\frac{50 Mb}{s} \div 2) \div \frac{5.12 Mb}{s} = 4.88$
 - Maximum amount of SVM publishers for 60 Hz system = 4
 - $(\frac{50 Mb}{s} \div 2) \div \frac{6.15 Mb}{s} = 4.06$
 - Available communication capacity considering two SMV publishers
 - SMV = 12.3 Mb/s
 - GOOSE + MMS = 37.7 Mb/s

For the proposed architecture of the MV switchgear with two SMV publishers (sharing of busbar voltage) 100 Mb/s Ethernet using either PRP or HRS communication redundancy principles has sufficient communication capacity to transfer all required data among IEDs and to SCADA system. Other potential future applications with process bus in MV switchgears and networks where higher number of SMV publishers are expected 1 Gb/s Ethernet is highly recommended.

7.2.4 Fourth step - Selection of communication architecture and redundancy principle

Reliability of the MV switchgear is one of the most important attribute. All components and systems in the switchgear are expected to work without faults and disruption of energy distribution in steady state conditions. When fault appears protection and control schemes implemented in IEDs play a key role to distinguish fault stage from normal stage and consequently, selectively clear the fault. Reliable and proper behavior of IEDs requires reliable and accurate input data. Measurements of the currents and voltages are part of these input data. This thesis already explained properties of the current measurement by the Rogowski coil and voltage measurement by the voltage divider and further implementation aspects of measuring devices in MV switchgears. In order to achieve decoupling of engineering aspects of measuring apparatuses from protection schemes and settings standard feeders were designed in such way that all measurements are always available independently from the application and final protection schemes. This approach requires to deploy in MV switchgear or system communication process bus to publish measurements, especially bus bar voltages. Communication architecture where digital measurements are broadcasted for the further use by protection and control schemes must meet the best reliability and availability criteria.

To fulfill the stringent reliability requirements of communication while maintaining the interoperability of IEDs in Substation Automation Systems (SASs), IEC 62439-3 [22] defines two redundancy protocols:

- 1) Parallel Redundancy Protocol (PRP) (IEC 62439-3 Clause 4)
- 2) High-availability Seamless Redundancy (HSR) (IEC 62439-3 Clause 5).

The two protocols employ different approaches and infrastructures. The PRP protocol duplicates the data frames to be transmitted, patches a redundancy control trailer (RCT) with a unique sequence number to the end each of the frames, and send them through two independent similar-topology LANs (IST-LANs). The receiver identifies the frames by the RCT and the source MAC address, accepts and processes the first arrival data frame, and then discards the second if it ever comes. Since the RCT is patched at the end of the content of a data frame, it can be ignored by the PRP non-compatible equipment. This approach ensures that the PRP protocol works with both PRP compatible and non-compatible equipment as long as the transmitter and receiver ends are PRP compatible. Typical architecture of PRP system is in the Fig.7-8.

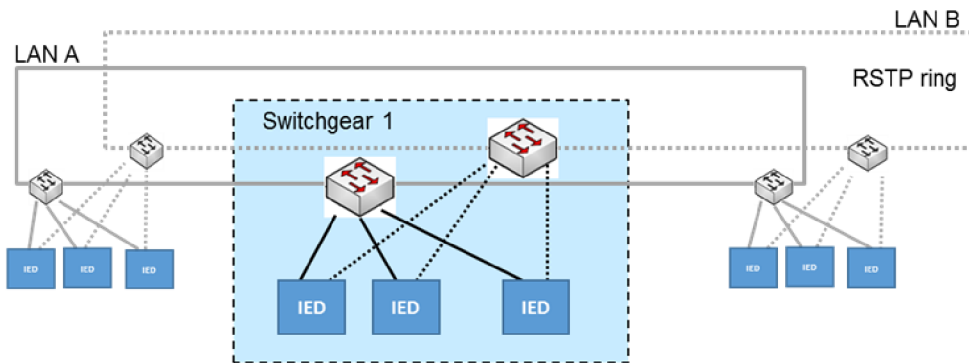

Fig. 7-8 : Sub-network with 2 PRP LANs, backbone network with 2 RSTP rings

Similarly the HSR protocol duplicates a data frame and sends both data frames through both directions to a ring-topology local area network (RT-LAN). On the ring, each device incorporates a switch element that decides either to forward or discard the frames from one port to the other. However instead of patching at the tail, HSR protocol inserts a header between the MAC header and the payload of the data frame. Consequently, the HSR tagged data frames will be processed only by the HSR compatible network equipment, and dropped as bad frames by HSR non-compatible equipment. Typical architecture of HSR system is in the Fig. 7.11.

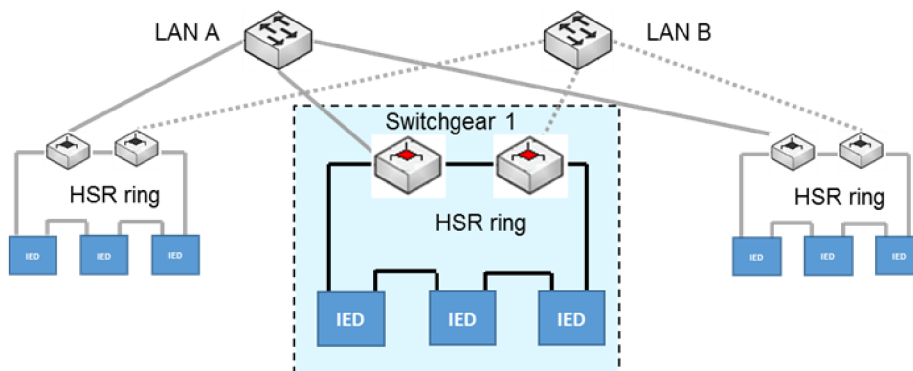

Fig. 7-9 : Sub-network with 2 PRP LANs, backbone network with 2 RSTP rings

Various aspects must be considered when proposing the best communication architecture for the particular application. Comparisons of what is important to be considered for process bus applications communication architecture is summarized in Tab.7-1. PRP, HSR but also Single network using RSTP are compared. It is very clear that single network topology with RSTP is not suitable for process bus applications. Most critical is the loss of data communication when active network component (e.g. Ethernet Switch) is lost. Recovery time of RSTP ring takes unacceptable time as well. Comparisons of PRP and HSR does not give a clear answer which redundancy principle would be preferred solution for the application of process bus in MV switchgears. In order to determinate which redundancy principle is better reliability calculations were made.

APPLICATION OF SENSORS AND DIGITALIZATION BASED ON IEC 61850 IN MEDIUM VOLTAGE NETWORKS AND SWITCHGEARS

Tab. 7-1 : Comparisons of communication architecture attributes

ARCHITECTURE	SINGLE network using RSTP	PRP networks	HSR network
Supported topologies	Any topology: tree, star, ring, meshed	Any topology: tree, star, ring, meshed	Limited: rings, rings of rings
Connecting single port IEDs	Yes	Yes, directly to one network	No, only via RedBox
Number of IEDs	No limitations, due to flexible topology	No limitations, due to flexible topology	Max 30 per ring
Network independent of IEDs	Yes	Yes	No
INTEROPERABILITY			
Interoperability with non redundant IEDs	Yes	Yes	No, only via RedBox
Compatible with standard Ethernet Components	Yes	Yes	No, HSR support is needed
PERFORMANCE			
Recovery time	10...500 ms	0ms	0ms
Network bandwidth	Full bandwidth	Full bandwidth	Half bandwidth
Latency	No latency in IED	No latency in IED	Latency in each IED
AVAILABILITY			
Failure of a switch / active network component	Connected IEDs are lost	No impact	One IED is lost
Failure of 2 or more IEDs	No impact to communication	No impact to communication	Communication between IEDs interruption
Data loss	Yes	No	No
ECONOMICS			
Equipment costs	Medium, Ethernet switches	High, double amount of Ethernet switches, IED with more interfaces	Medium, RedBox, IED with more interfaces
Communication Links	Medium, links between IEDs and Ethernet switches	High, double links between IEDs and Ethernet switches	Low, only links between IEDs
Space requirements	Medium, Ethernet switches	High, Ethernet switches	Low, less devices
ENGINEERING			
Effort	Less	More	Less

7.2.5 Reliability study of PRP and HSR redundant communication architectures

Reliability is one of the most important aspects of SAS design. IEC 81650-90-4 [20] engineering guidelines describes a number of communication systems for SAS. System can be design in many different ways and therefore it is important to understand reliability pictures of different architectures. IEC 61850 SAS communication reliability investigations can be also found in [20]. Performance of communication in relation to tripping times is also important parameter. Investigation of performance was not part of this thesis, however more details can found in [12].

Key reliability parameters of the system are:

- Reliability [%]
- Availability [%]
- (MTTF) Mean Time To Failure [years]
- (MTTR) Mean Time To Repair [hours]

Above reliability pictures were calculated by ABB VisualMTTF tool. The tool is designed to consider both elements reliability and system topology for the overall calculation of the system reliability pictures. Elements reliability are MTTF and MTTR data defined by the user for particular component in the system. System topology can be freely defined in graphical editor by instantiation and connections of the substation elements. Final input information is dependency expression which defines information flow.

Once all data are defined tool uses following calculation principle to calculate reliability Pictures.

1. Dependency expression

e.g: $A > B \& (C|D) \dots$ *Dependent: A, Dependent upon: B, C, D*

2. Transformation of dependency expression into directed graph

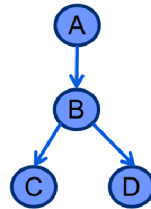

3. Calculation Minimum Cut Set (MCS)

Combination of elements which when not working make the information flow to fail

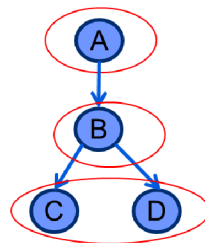

Minimum cut set: {A}, {B}, {C,D}

4. Expansion of minimum cut set

Deduce paths between sink and elements of every MCS OR join the paths (need to jointly fail). Recalculate MCS. Remove duplicates.

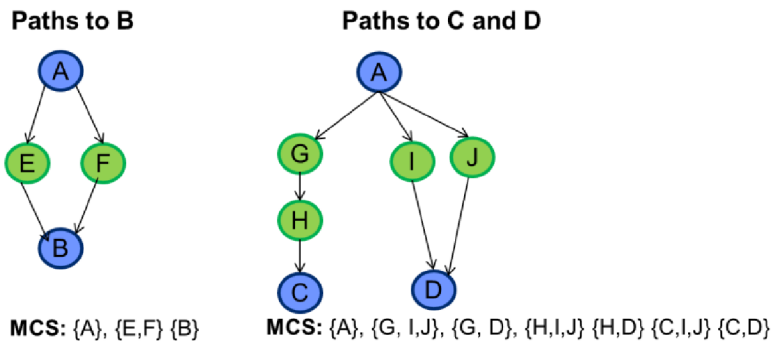

5. Build Binary Decision Diagram (BDD)

BDD is a graph representation of a Boolean expression

AND-join: elements within each MCS

OR-join: these AND-expressions to one BDD

Final formulas for reliability Pictures calculations based on BDD

System reliability:

$$R(t) = 1 - f(BDD_{root})$$

$$f(BDD_{node}) = (1 - x_{node}) \times f(x_{node}^{left}) + (x_{node}) \times f(x_{node}^{right})$$

$$x_{node} = e^{-t/elementMTTF}$$

System availability:

$$(A) = 1 - i(BDD_{root})$$

$$u(BDD_{node}) = (1 - y_{node}) \times u(y_{node}^{left}) + (y_{node}) \times u(y_{node}^{right})$$

$$y_{node} = e^{elementMTTF/elementMTTF+elementMTTR}$$

MTTF:

$$MTTF = \int_0^{1000} R(t)dt$$

MTTR:

$$MTTR = MTTF \times \left(\frac{A}{1 - A} \right)$$

Tab.7-2 includes MTTF and MTTR data of elements used for reliability calculations.

Tab. 7-2 : MTTF and MTTR data of the components used in calculation

	MTTF(y)	MTTR(h)
REF 615	100	4
RuggedCOM Ethernet Switch	100	4
KEVCD Rogowski coil	400	8
KEVCD Voltage divider	400	8
Fibre optics	1000	1
Wire	1000	1

Results of the reliability calculations for PRP redundancy communication architecture are visible from the Fig.7-10, taken as screen shot from the calculation tool.

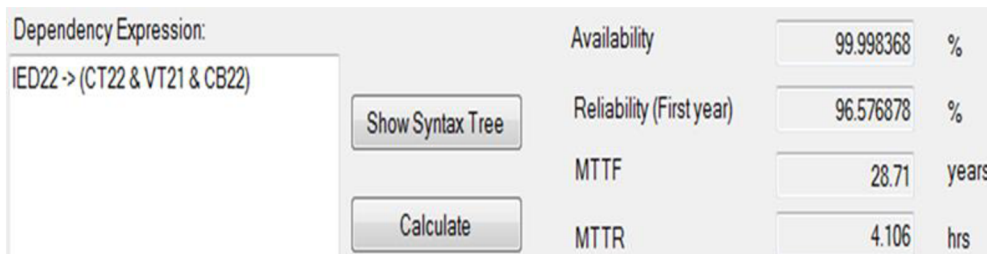

Fig. 7-10 : Reliability calculation results of PRP redundancy

Results of the reliability calculations for HSR redundancy communication architecture are visible from the Fig.7-11, taken as screen shot from the calculation tool.

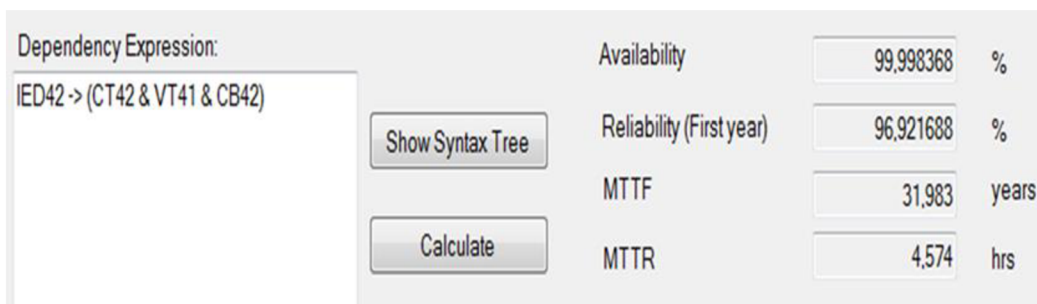

Fig. 7-11 : Reliability calculation results of HSR redundancy

Above results of the reliability pictures calculation shows slightly better results of HSR redundancy principle, however difference in comparison to PRP redundancy principle is

so small that conclusion of both redundancy communication principles are suitable for the process bus application in MV switchgears can be made.

7.3 Overall conclusions – Architecture of MV switchgear with sensors and process bus

Implementation of Rogowski coil and voltage divider in MV networks requires new approach. Simple one to one replacement of current and voltage transformer by sensors without looking at system aspects would be a mistake that could lead to a system which would not be either functional or applicable in real installations. The major reason to look at sensors implementation in MV networks from the system stand point is the fact that sensors output signal has low voltage character. This type of signal requires different techniques of distribution in comparison to what is used for conventional instrument transformers. Digitalization by implementing of IEC 61850 process bus in substation is the best concept of any measurements distribution within substation. Deployment of the process bus can be done in many ways. Character and architecture deployment of the process bus drives application and economical aspects. Key components of the process bus is merging unit which reads analog data from the different apparatuses, digitalize and publish data to communication system for further processing in protection and control schemes.

As far as the MV switchgears are concerned the best approach appears to include MU functionality to bay level IED. Signals between all sensors and bay level IED are transferred in analog format through hardwiring. IED beside tasks of protection and control of the particular bay acts as MU, so it can publish required substation events and SMV to the communication system for further processing as well as it can subscribe substation events and SMV from the communication system for protection and control purposes of its bay.

Use of sensors and digitalization offers to decouple measuring devices engineering aspects from the short circuit selectivity study and offers higher flexibility to define and change protection schemes through the entire life cycle of the MV switchgear.

Decoupling of measuring apparatus engineering aspects from the protection engineering allows to define standard layouts and single line diagrams of the feeders. Combination of predefined standard feeders with communication bus and possibility to share needed substation events and SMV across substation through communication bus builds assumption that any bay data can be flexibly available for any other bay within substation. This thesis suggests the standard layout of MV switchgears feeders with Rogowski coil and voltage divider that must satisfy the needs of vast majority of the MV switchgears applications and demonstrates that decoupling of measuring apparatus engineering aspects from the short circuit selectivity study and relay engineering is possible.

Deployment of the process bus where critical data for proper protection and control functionality of the system are shared requires perfect understanding of all communication aspects.

First important aspect is available communication bandwidth. This thesis shows that 100 Mb/s Ethernet fully meets communication capacity requirements for the particular application of busbar voltage sharing. Two SMV publishers requires 12.3 Mb/s capacity and remaining 87.7 Mb/s is sufficient capacity for substation events communication among IEDs and to SCADA system including safety margin. Thesis confirms also the limits of communication capacity for 100 Mb/s Ethernet what comes to application of process bus. In general, depending on selected redundancy principle in 50 Hz system, max. 9 IEDs for PRP respectively max. 4 IEDs for HSR can be used as generic SMV publishers when 100 Mb/s Ethernet is used. That means any potential application of process bus requires to check available Ethernet communication bandwidth and decision whether 100 Mb/s or 1 Gb/s shall be used.

Second important aspect is the choice of Ethernet communication architecture. Conclusion of the thesis is that single communication system with RSTP is not recommendable due to long recovery time of communication after communication failure and total data collapse if the Ethernet switch fails. Either PRP or HSR redundancy principle must be used for the purpose of SMV share in the substation through the communication. Reliability figures of both redundancy architectures were compared and conclusion if one or the other redundancy principle is better for MV switchgears where SMV are shared in communication bus cannot be made. Both redundancy principles have different pros & cons and use of them is application related.

8 EXAMPLE OF THE NEW SUBSTATION ARCHITECTURE APPLICATION

8.1 Verification of hypothesis – digital switchgear

The idea to combine sensors with digital communication where sampled measured values are shared for protection and measuring purposes in MV switchgears was presented by me in the year 2008. It took several years of detailed investigations and development efforts to deliver product that can be produced and delivered for real application. All these efforts, organization of development teams, definitions of the product architecture, testing, investigations and measurements were made under my leadership. This thesis is representing certain fraction of the entire complex development that was finalized by the first release of the ABB UniGear Digital concept in the year 2013. All details about the product can be found on following web page:

<http://new.abb.com/medium-voltage/switchgear/air-insulated/iec-and-other-standards/unigear-digital>

Since 2013 product is being promoted by ABB to the industry and MV experts' community. MV experts could see this product on various exhibitions, fairs and international MV conferences including 22nd CIRED (International conference and exhibition on electricity distribution) in Stockholm and 23rd CIRED in Lion. Product was awarded as best technical display on two fairs and also recognized as one of the 2014 top innovative products in ABB.

- 22nd Trade Fair Amper 2014 in Brno, Czech Republic – Gold Medal
- 27th International Power Industry Fair in Bielsko Biala, Poland – Gold Medal

Beside recognition of the product by the MV experts, product is being recognized also by the industry. Industry sees this product as an alternative to conventional switchgear architecture and understand its added value in MV application. Main values of the product are following:

Safe and reliable

- Increases equipment reliability
- Increases safety level in your substation
- Extended communication supervision functionality is available

Simple and efficient

- Minimizes lifetime costs during switchgear operation
- Saves space in your switchgear room by reducing switchgear footprint
- Offers 30 % quicker delivery time from order to switchgear operation

Intelligent and ready for the future

- Provides flexibility towards varying load flows
- Provides flexibility during switchgear operation
- Offers possibility of late customizations and changes

Lower environmental impact

- Lowers energy consumption up to 250 MWh which represents saving of 13 000 EUR, compared to typical substation with 14 switchgear panels of UniGear ZS1 type over 30 years of operation.
- Saves up 150 tons of CO₂, that is equal to emissions produced by mid-size European car driven for 1 250 000 km

Product was delivered and installed to several countries in Europe, Middle East and Africa, to utility customers as well as various industrial customers. I believe that success of this product both between MV experts and industry creates foundations of future trend how to build MV switchgears in a different way.

8.2 Example of the product application

One of the many interesting installation was delivered for Fortischem a.s. Novaky in Slovakia. It is a petrochemical industry installation.

Factory is supplied directly from 110 kV. Due to the nature of the production the system of energy supply is fully backed up from two independent 110 kV distribution substations. Energy distribution in factory is managed through internal 22 kV distribution system and further 6 kV distribution system which either feeds directly large loads or energy is further transform to LV level for the supply of the LV loads.

Factory had total failure in one of the 22 kV and 6 kV substations which caused large scale of fire event and damaged all switchgears in substation. Reasons of the failure has not been disclosed. Replacement of damaged substations had two major challenges specified by the client.

- To provide fully operational stations as quickly as possible for 6 kV and 22 kV with a minimal downtime as replacement of old damaged substation
- To increase automation level in the substation with latest available technologies, such as communication to monitoring room, integrated Arc protection and switchgear condition monitoring functions

8.2.1 Use of the typical feeders with sensors and digital bus

As explained in chapter 7, use of sensors and digital communication allows to decouple engineering of the protection and control system from the engineering of the switchgear hardware. Decoupling represents significant time savings during engineering phase of

any project. This possibility was offered to client and it played an important role in decision process to choose UniGear Digital as product for the replacement of the damaged switchgears in 22 kV and 6 kV substations. Delivery included 35 panels of UniGear ZS1 17.5 kV for two 6 kV substations and 27 panels of UniGear Digital 24 kV for one 22 kV system. Complete project was delivered on April 2014. Example of the project documentation for one of the 6kV switchgear system can be found in Appendix 10. Complete documentation includes 461 pages, therefore only important parts of the documentation are included in Appendix 10 in order to demonstrate implementation of sensors and digital communication in MV switchgear as shown in this thesis.

Single line diagram of the 6kV substation section A shows use of the proposed typical feeders as explained in chapter 7.

- Panel no. 8 represents incoming feeder where voltage measurement and current measurement is done according proposed incoming feeder single line diagram on the Fig.7-3. Additional instrument transformers shown on project single line diagram are used for tariff energy metering purposes. There are two reasons why sensors are not yet used for tariff energy metering purposes. Firstly, producers of the energy meters do not offer an option to measure currents from the sensors and secondly the legislation of sensors calibrations for tariff metering purposes in particular countries does not exist.
- Panels no. 1, 2, 3, 4, 5, 6, and 9 are future outgoing reserves. Panels are fully designed according proposed outgoing feeder presented in chapter 7 on the Fig.7-6. Panel no. 9 includes voltage transformers that are us for the purpose of the tariff energy metering. Reasons are described above.
- Panel no. 7 is outgoing future reserve with busbar voltage measurement according proposed typical outgoing feeder on the Fig.7-4. IED in this feeder is publishing SMV of busbar voltage for further processing in the substation.
- Panels no. 12, 13, 14, 15, and 16 are outgoing feeders feeding existing production technologies. Panels are fully designed according proposed outgoing feeder presented in chapter 7 on the Fig.7-4. All panels includes additional current transformers for the tariff metering purposes. Reasons are the same as described in panel 8 above.
- Panel no.17 is bus coupler with circuit breaker and its diagram is fully in line with proposed typical bus coupler described on the Fig.7-5.

All outgoings panels use ring core balance transformer mounted in cable compartment below switchgear frames for the residual current measurement purposes. Client was not offered with an option of the residual current calculation from line currents measured by the Rogowski coil, due to the fact that application uses neutral grounded trough Peterson coil. Additional measurements and field testing is needed in order to confirm reliable functionality of the residual current calculation from line current measured by sensors for system with commentated neutral grounding. Calculation of residual voltage in the IED from line voltages measured by sensors is used in this application.

8.2.2 Selection of communication architecture

As explained in chapter 6 there is not unique communication architecture which would be always applicable. Final communication architecture is always compromise between required.

- Reliability and availability
- Number of IEDs in one substation
- Number of substations to be connected in complete system
- Physical location of the substations and distances
- Costs of the system

Figure X.7 in Appendix 10 shows complete communication architecture. Complete project as mentioned above includes three independent substations. Every substation uses HSR redundant topology where each end of the particular ring is connected to independent switch. Upper level architecture above HSR rings of each substation is fully redundant and it uses PRP redundancy principal. Ethernet switches manage communication to control system through two parallel fully redundant links. HSR redundancy is economically much better than PRP, HSR has however certain limitations that must be always verified. As explained in chapter 6 use of HSR with process bus is possible if applications includes less than 31 IEDs per substations and amount of the SMV publishers is less than four. This project meets both criteria therefore HSR redundancy at substation level was possible to use.

8.2.3 Interlocking, blocking, control and measurement schemes through digital bus

Detailed drawings of the complete substation protection and control scheme can be found on pages in Appendix 10. Drawings explain signals and events published and subscribed by each IED for the particular functionality. In addition there is a separate PLC logic configured in every IED which is not presented in this thesis, but it can be delivered upon request. Purpose of these drawings for the scope of this thesis is to demonstrate on real example how the one digital communication bus can be shared for all type of data, events and SMV. As described in chapter 7, IEC 61850 describes three types of events or data that can be transferred over Ethernet communication.

- 1) MMS (Manufacturing Message Specification). Communication between IEDs and SCADA system. Each IED sends standard dataset that includes all data, events and alarms needed for SCADA or DCS system. All datasets between IEDs and control system are communicated through separate logical V-LAN on the same physical layer. Possibility to create VLAN for certain communication within the same physical communication is a standard feature of the Ethernet. This allows to decouple GOOSE and SMV signals from MMS telegrams. MMS telegrams through VLAN are set to lowest priority, so the GOOSE and SMV signals are always prioritize when passing through Ethernet switch or component.

- 2) GOOSE (Generic Object Oriented Substation Event). Communication among IEDs. Each IED publishes to the digital bus configured dataset needed for particular requirements of every substation control, interlocking and blocking logic. Each IED subscribes from the digital bus events published by other IEDs needed for the logic in that IED. Advantage of realizing substation control, interlocking and blocking schemes through digital bus is high flexibility and possibility to freely modify logic through entire life cycle of the switchgear. Described project includes following substation logic fully realized through digital bus:
- i. **Arc protection** (Appendix 10, Fig. X-8) – Each panel includes three arc sensors. One in cable compartment, second in circuit breaker compartment and third in busbar compartment. Depending upon in which panel and compartment is the arc detected control scheme decides to open appropriate circuit breaker in order to immediately cut energy which could further feed energy to potentially developed arc.
 - ii. **Circuit breaker failure protection** (Appendix 10, Fig. X-9) – Each circuit breaker has mechanical auxiliary contact which indicates mechanical failure of the main contacts. Each outgoing feeder publishes status if this signal. In the event of outgoing circuit breaker indicates mechanical failure incoming and bus coupler circuit breakers are tripped. In the event of the bus coupler circuit breaker mechanical failure both incoming feeders are tripped and finally in the event of incoming feeder mechanical failure of the circuit breaker corresponding upper level 110 kV circuit breaker is tripped.
 - iii. **Blocking of the incoming instantaneous overcurrent protection function** (Appendix 10, Fig. X-9) – Each outgoing feeder publishes status of the high stage overcurrent protection start signal. Active start signal from any outgoing feeder ensures blocking of the instantaneous overcurrent protection function in incoming feeders, which ensures selective trip of the outgoing feeder with fault, without the trip of the incoming feeder.
 - iv. **Blocking of the busbar earthing switch** (Appendix 10, Fig. X-10) – Earthing switch can be closed when all circuit breakers in the particular substation section are in service position. All feeders publish position of the circuit breaker truck. Once all trucks are in service position IED in panel 14 or 3 energizes blocking coil of busbar earthing switch which allows its mechanical closing. When busbar earthing switch is closed, panels 14 and/or 3 publish signal to the bus which is subscribed by all IEDs. Internal logic in all IEDs blocks possibility to rack in circuit breaker to test position.

- v. **2 out of 3 interlocking scheme** (Appendix 10, Fig. X-11 and X-12) – 6kV substation is separated to two sections. Each section has independent incoming feeder. Both sections are connected through bus coupler which is operated with normally open circuit breaker. Bus coupler circuit breaker is closed only in case that one of the incoming feeders is disconnected from its section. This ensures continuity of the energy supply for the section where incoming feeder cannot supply energy for its section. 2 out of 3 interlocking scheme ensures that incoming feeders are not operated in parallel if the upper level system does not allow paralleling of two independent energy systems. Incoming feeders and bus coupler publish position of trucks and circuit breakers. These data are subscribed by IEDs in all three feeders and logic inside IED ensures that circuit breaker can be closed in case that parallel operation of the energy sources is excluded.
 - vi. **Internal relay fault supervision** (Appendix 10, Fig. X-13) – This specific simple system ensures monitoring of the IED health by the neighboring IED. Each IED sends its health status event (LD0.LLN0.Health.stVal) to neighboring IED. In the event of any IED internal faults indicated through mentioned signal, IED in next panel sends this information to control room as an alarm signal.
- 3) **SMV (Sampled Measured Values)**. Communication between process level (e.g. sensor, actuator) and station system. According to drawings on page in Appendix 10, Fig. X-14 outgoing feeder 7 in section A and outgoing feeder 10 in section B publish SMV of bus bar voltage in particular sections. Voltages are subscribed by all outgoing feeders in corresponding section for further processing.

9 CONCLUSIONS AND CLOSINGS

Introduction part summarized current state-of-the art of the architecture and basic technologies used in MV air insulated switchgears. It also offered the most important and the most relevant summary of IEC 61580 use in MV application. Thesis explained, how likely is to expected major technology change in each basic functional part of the air insulated MV switchgear in the future. It is unlike to expect major change in basic structure and basic switchgear compartments organization and segregation. It is also unlike to expect substantial change in switching, disconnecting and insulating features. It was identified that measuring and sensing part of the switchgear is from the technology aging stand point, the part, where changes by means use of alternative principles other than inductive transformer principle are very likely to happen in the near future. All known current and voltage measurement principals were listed and compared from costs and accuracy stand point.

This comparison led to a conclusion that the best alternative current measuring technology in MV applications is a Rogowski coil and the best alternative voltage measuring technology in MV applications are capacitive and resistive dividers. Selected alternative measuring principals alone, would not have been able to create any change in architecture, engineering and design approach of MV air insulated switchgear. Thesis showed that how the application of the selected measuring principles with IEDs and digital bus with IEC 61850 creates new approach in architecture, engineering and design of MV switchgear.

Correct application of any technology requires detailed analysis of the targeted application constrains impact on the technology as such. MV application domain is very wide. This thesis was focused on MV air insulated switchgears.

Accuracy of the measurement is the most critical parameter for its further use and processing by IEDs. It is critical to ensure that measuring signal at IED interface is within required accuracy limit and particular application specific factors do not influence accuracy measurement in such way, that required accuracy limits are not met.

The first part of the thesis specified what are the most important potential influencing factors in MV air insulated switchgears, which must be analyzed when applying Rogowski coil and voltage dividers. Following external parameters have been identified to be analyzed.

1. Ambient temperature
2. Cable length between sensor and IED
3. Frequency response

All measurements made on ABB Rogowski coil showed acceptable immunity of above listed factors to final accuracy of the measurement and below are most the important findings.

1. Both amplitude and phase displacement errors of the current measurement within whole defined ambient temperature range ($-40^{\circ}\text{C} \rightarrow 115^{\circ}\text{C}$) in MV switchgears shows errors within 0.2 accuracy class defined by IEC 60044-8 [5]. Current measurement by the Rogowski coil can be used for both protection and measuring application within complete ambient temperature range that can occur in MV switchgear.
2. Examined length of the cable (up to 100 m) between Rogowski coil and IED showed that even 100 m distance fulfills requirement of the accuracy limits for protection purposes defined by IEC 60044-8 [5], however if the accurate measurement of higher frequencies is required distance between Rogowski coil and IED shall not exceed 6.5 m in order to fulfill measuring accuracy limits defined by IEC 60044-8 [5].
3. Frequency response of the Rogowski coil as such is satisfactory and fulfills all accuracy class limits defined by IEC 60044-8 [5]. Accuracy measurement however showed that cable length between Rogowski coil and IED limits accuracy of the Rogowski coil frequency response. Same confusion like in previous paragraph is applicable.

In general error pattern of the Rogowski coil always showed constant trend which is important for further possible correction in electronic device.

ABB Resistive divider accuracy explorations showed following results and conclusions.

1. Both amplitude and phase displacement errors of the voltage measurement within whole defined ambient temperature range ($-40^{\circ}\text{C} \rightarrow 115^{\circ}\text{C}$) in MV switchgears shows errors within 0.5 accuracy class defined by IEC 60044-7 [4]. Voltage measurement by the voltage divider can be used for both protection and measuring application within complete ambient temperature range that can occur in MV switchgear.
2. Examined distance of the cable (up to 100 m) between resistive divider and IED showed that maximum recommended cable length is 20 m. This cable length fulfills requirement of the class 1 accuracy limits for protection purposes defined by IEC 60044-7 [4].
3. Frequency response of the resistive divider is depended on cable length to IED. In order to fulfill voltage measuring class 1 defined by IEC 60044-7 [4] for protection purposes cable length shall not exceed 20 m. As far as the metering purposes are concerned, where measurement accuracy up to 1500 Hz is required cable length shall not exceed 20 m in order to meet criteria of the measuring class 1 defined by IEC 60044-7 [4].

In general error pattern of the resistive divider always showed constant trend which is important for further possible correction in electronic device

ABB Capacitive divider accuracy explorations showed following results and conclusions.

1. Amplitude error of the capacitive divider is proportional to ambient temperature increase in such way that both amplitude and phase displacement errors above 40°C exceeds class 3 accuracy limits defined by IEC 60044-7 [4]. This practically exclude use of capacitive dividers in MV switchgear application where ambient temperature can reach +110°C.
2. Influence of cable length between capacitive divider and IED on measurement accuracy has not been investigated
3. Capacitive divider as such showed good performance what comes to frequency response. Accuracy measurement up to 1500 Hz fulfilled criteria of the class 1 defined by IEC 60044-7 [4].

It can be concluded that capacitive divider is good alternative when high accuracy of high harmonics measurement is required, however it can be used only in environment where ambient temperature does not exceed 40°C.

The second part of this thesis showed how the application of the Rogowski coil can change approach in protection application area. Target was to explore if the measurement of line currents by the Rogowski coil and further mathematical calculation of residual current by IED can be an alternative to measurement of residual current by core balance transformer.

The first step was verification of apparent residual current value as function of increased line currents values – stability of the system. The conclusion from static tests performed is that Rogowski coil enables more accurate signal transformation in comparison to inductive based transformers, particularly for very low and very high primary currents. Using of sensors enable setting of earth fault protection for 1% of primary rated current 40 A for low primary currents and 3% of primary rated current 40 A for high primary currents. The measurement with high primary current verified the correct behavior of sensors and their linear non-saturated characteristic.

- 1) **For nominal current I_{pn} 80 A = rated primary current of sensor I_{pr} 80 A**
It was measured currents from 5% up to 120% of $I_{pr}=80$ A where the nominal current parameter I_{pn} was set to 80 A as well. Mean root-square error of value read from REF615 HMI (in the range 0.060-0.136 A) was slightly higher than mean root-square error of injected current (in the range 0.050-0.098 A).
- 2) **For nominal current I_{pn} 1000 A \neq rated primary current of sensor I_{pr} 80 A**
It was measured currents from 5% up to 120% of $I_{pr}=80$ A where the nominal current parameter I_{pn} was set to 1000 A. Mean root-square error of value read from

REF615 HMI (in the range 0.110-0.544 A) was higher than mean root-square error of injected current (in the range 0.060-0.080 A)

It is recommended to use the same settings for both parameters – the Nominal current as well as the Primary

The second step was to verify behavior of earth fault protection when residual current is calculated from line currents measured by Rogowski coil. Verification in single phase configuration showed that measured asymmetrical apparent residual current has very small value, which is always safely below typical pick-up values of earth fault protection. Further measurements in three phase configuration confirmed results from single phase configuration. $I_{o(ap)}$ created as results of unbalanced current between phases due to the different accuracy of the sensors in each phase increases with measured current I_p . $I_{o(ap)}$ expressed as percentage value of measured current I_p has exponential character. Gap between minimum pick up residual current and residual apparent current gives a sufficient safety margin that allows to make conclusion that calculation of the residual current by the IED for earth fault protection from the line currents measured by Rogowski coil will always work in isolated and directly earthed neutral. Reliable application of residual current calculation by IED in MV networks where neutral is earthed through Petersson coil (compensated networks) requires to make field measurements.

The final step was measurement on primary network model where following simulations confirmed no false trip of earth protection when measuring calculating residual current from line currents measured by the Rogowski coil.

- Power transformer inrush current in the system
- Different resistance of the fault currents in isolated neutral networks
- Different resistance of the fault currents in high impedance neutral grounding networks

Based on all measurements done it can be concluded that new rules can be recommended when calculating residual current in IED from the line to ground current measurements by the Rogowski coil. This rules are limited to isolated neutral MV networks and high impedance neutral grounded networks.

- MV feeders up to $I_r = 3150$ A and $I_k'' = 31.5$ kA. Earth fault currents above 1% of the nominal current can be safely calculate by the IED from the line to ground currents measured by the Rogowski coil
- MV feeders up to $I_r = 4000$ A and $I_k'' = 50$ kA. Earth fault currents above 3% of the nominal current can be safely calculated by the IED from the line to ground currents measured by the Rogowski coil

The third part of this thesis described seamless integration of sensors and communication bus based on IEC 61850 to medium voltage substation made of air insulated switchgears. Four universal feeders layout were designed in such way that it allows to decouple measuring devices engineering aspects from short circuit selectivity study. This is an important difference to current practice where parameters of inductive based transformers are always given as result of particular short circuit selectivity study. Available communication bandwidth was verified for proposed MV substation architecture. Generally used 100 Mb/s Ethernet has sufficient bandwidth to manage required stream of sampled measured values given by proposed application, but also GOOSE messaging between feeders and MMS messages to control system. Thesis explained also the limits of communication capacity for 100 Mb/s Ethernet what comes to application of process bus. In general, depending on selected redundancy principle in 50 Hz system, max. 9 IEDs for PRP respectively max. 4 IEDs for HSR can be used as generic SMV publishers when 100 Mb/s Ethernet is used. That means any potential application of process bus requires to check available Ethernet communication bandwidth and decision whether 100 Mb/s or 1 Gb/s shall be used.

Important aspects of the Ethernet communication architecture were explained. Conclusion of the Chapter 7.2.4 is that single communication system with RSTP is not recommendable due to long recovery time of communication after communication failure and total data collapse if the Ethernet switch fails. Either PRP or HSR redundancy principle must be used for the purpose of SMV share in the substation through the communication. Reliability figures of both redundancy architectures were compared and conclusion if one or the other redundancy principle is better for MV switchgears where SMV are shared in communication bus cannot be made. Both redundancy principles have different pros. & cons. and use of them is application related.

The final part of this thesis demonstrated real application of the proposed architecture in real substation.

Example of the project verified combination sensor – IED – digital communication in real substation application. There are many more applications of this architecture that can be presented upon request. Most important is that idea of typical MV feeders as proposed in this thesis works. Real project confirmed that these typical feeders have such an universal lay out that allows decoupling of protection & control schemes engineering from the switchgear hardware engineering. Project confirmed that typical feeders offer high degree of flexibility through entire life cycle of the switchgear. Project includes high amount of the spare feeders for the future use. They can be easily connected to loads and overall substation logic without engineering or changes of the switchgear hardware. Software setting in IED will be only required change when spare feeder will be connected to the load in future.

Practical experience from this project but also from other projects showed that acceptance to change approach in protection schemes and further utilization of the quality

measurements by sensors in protection application will take some time. Customers still prefer to use core balance transformer to measure residual current in earth fault protection application. Virtual calculation of residual voltage in IED even through measurement shared on digital bus is generally accepted. This thesis showed that virtual residual current calculation in IED from line currents measured by Rogowski coils shall be possible. There is however a need to make more field measurements in different type of networks in order to have better arguments when deploying this change in industry. Additional hurdle towards to layout of the MV substation without instrument transformers is tariff metering. Even sensors can reach required accuracy classes for the tariff metering there are simply no energy meters on the market that can receive analog signal from the sensors. Additional issue is the legislation in different market that would require to define and accept verification of sensors accuracy classes.

Most important is to stress that transition period from traditional switchgears to switchgears with sensors and digital bus requires flexibility. It means possibility to combine old technology with new technology and search for intersections between what industry and particular customer is ready to accept and where the preference of stay traditional is predominant. This flexibility also allows to collect experience from the real application and helps to understand what the important areas are, as a next focus of the additional testing and development in order to convince industry to use fully digital MV switchgear without traditional technologies. ABB UniGear Digital concept offers this flexibility and that is why it is pioneering product towards to future fully digital MV substations.

My main contributions to the field of energy transmission and distribution and my work and studies in last 6 years about the subject of this thesis can be summarized as follow:

- 1) Detailed view on Rogowski coil, resistive and capacitive divider accuracy measurement constrains in medium voltage applications. Verification that Rogowski coil and voltage dividers are better alternative for current and voltage measurement in MV application than inductive based instrument transformers.
- 2) Practical demonstration based on earth fault protection example how the use of the Rogowski coil for current measurement can change today's practices in residual current measurement and earth fault protection.
- 3) Definition of standard medium voltage feeders with sensors that allows decoupling of measuring devices engineering aspects from protection and control engineering.
- 4) New MV substation architecture proposal with seamless integration and utilization of sensors – IEDs – digital communication based on IEC 61850 utility and industry standard.

LIST OF PICTURES

Fig. 2-1 : Cross section view ABB UniGear ZS1 [8]	12
Fig. 2-2 : Cross section view Eaton 7.2kV Switchgear [9]	12
Fig. 2-3 : Cross section view Siemens NXAir [10]	12
Fig. 3-1 : Relations between accuracy and costs of available current sensing tech.	16
Fig. 3-2 : Basic Rogowski coil with return wire thru the winding center	17
Fig. 3-3 : Schematic comparison of the Rogowski coil and IT characteristics	17
Fig. 3-4 : Combined accuracy limits of Rogowski coil at const. ambient temp. [23]	18
Fig. 3-5 : Relations between accuracy and costs of available voltage sensing tech.	19
Fig. 3-6 : Left - Resistive divider scheme and Right – example of the assembly.....	20
Fig. 3-7 : Left - capacitive divider scheme and Right – example of the assembly	20
Fig. 3-8 : Voltage accuracy class of voltage divider at const. ambient temp. [23]	21
Fig. 3-9: IEC 61850 Approach [6].....	24
Fig. 3-10 : Application domain of IEC 61850 in Substation	25
Fig. 5-1 : Definition of measurement accuracy chain according IEC 60044-8 [5].....	28
Fig. 5-2 : Operating temperature test cycle of the sensor accuracy	30
Fig. 5-3 : Storage temperature test cycle of the sensor accuracy	30
Fig. 5-4 : Extended temperature test cycle of the sensor accuracy	30
Fig. 5-5 : Frequency response of Rogowski for various cable lengths	38
Fig. 5-6 : Frequency response of Rogowski for various cable lengths	39
Fig. 5-7 : Frequency response of Resistive divider for various cable lengths.....	40
Fig. 5-8 : Frequency response of Resistive divider for various cable lengths.....	41
Fig. 5-9 : Frequency response of capacitive divider for 6.5 m cable length.....	41
Fig. 5-10 : Frequency response of capacitive divider for 6.5 m cable length.....	42
Fig. 6-1 : Example of core balance transformer	45
Fig. 6-2 : Ideal distribution of the line to ground currents in the 3-phase system.....	46
Fig. 6-3 : Apparent residual current $I_{0(ap)}$ in the 3-phase system and.....	46
Fig. 6-4 : Real residual current I_0 and apparent residual current $I_{0(ap)}$ relation	47
Fig. 6-5 : Phase disp. - real residual current I_0 and apparent residual current $I_{0(ap)}$	47
Fig. 6-6 : Earth fault protection for nominal current $I_{pn} = 40$ A, REF 615	50
Fig. 6-7 : Characteristics of $I_{0(ap)}/I_P = f(I_p)$ [%]	50
Fig. 6-8 : Block diagram of earth fault protection stability on inrush current	51
Fig. 6-9 : Block diagram – simulation of MV isolated neutral network	52
Fig. 6-10 : Intermittent earth fault DR - MV network with isolated neutral.....	53
Fig. 6-11 : Block diagram – simulation of MV high impedance neutral network	53
Fig. 7-1 : Block diagram - voltage and current distr. with instrument transformers.....	57
Fig. 7-2 : Typical substation configuration for MV air insulated switchgears	58
Fig. 7-3 : Typical incoming feeder with voltage measurement.....	60
Fig. 7-4 : Typical outgoing feeder with busbar voltage measurement	61
Fig. 7-5 : Typical bus coupler feeder with busbar voltage measurement.....	61
Fig. 7-6 : Typical outgoing feeder.....	62

Fig. 7-7 : Typical MV Substation architecture with sensors and digitalization [11] 64
Fig. 7-8 : Sub-network with 2 PRP LANs, backbone network with 2 RSTP rings 68
Fig. 7-9 : Sub-network with 2 PRP LANs, backbone network with 2 RSTP rings 68
Fig. 7-10 : Reliability calculation results of PRP redundancy 72
Fig. 7-11 : Reliability calculation results of HSR redundancy 72

LIST OF THE TABLES

Tab. 5-1 : Current transformers protection accuracy classes acc. IEC 60044-8 [5]	31
Tab. 5-2 : Current transformers metering accuracy classes acc. IEC 60044-8 [5]	31
Tab. 5-3 : Extended temperature cycle, accuracy of the Rogowski coil	31
Tab. 5-4 : Voltage transformers combined accuracy classes acc. IEC 60044-7 [4]	32
Tab. 5-5 : Extended temperature cycle, accuracy of the capacitive divider	33
Tab. 5-6 : Extended temperature cycle, accuracy of the resistive divider	34
Tab. 5-7 : Rogowski coil measurement accuracy as function of cable length	35
Tab. 5-8 : Resistive voltage divider meas. accuracy as function of cable length	36
Tab. 5-9 : Rogowski coil meas. errors influence by external fac. (App. 5, 6, 7, 8)	43
Tab. 5-10 : Resistive divider meas. errors influence by external fac. (App. 5, 6, 7, 8) ...	44
Tab. 5-11 : Capacitive divider meas. errors influence by external fac. (App. 5, 6, 7, 8)	44
Tab. 6-1 : Correction factors of used Rogowski coils	48
Tab. 7-1 : Comparisons of communication architecture attributes	69
Tab. 7-2 : MTTF and MTTR data of the components used in calculation	72

REFERENCES

- [1] IEC 62271 – 1. *High-voltage switchgear and controlgear - Part 1: Common specifications*. Geneva, Switzerland International Electrotechnical Commission
- [2] IEC 62271 – 200. *High-voltage switchgear and controlgear - Part 200: AC metal-enclosed switchgear and controlgear for rated voltages above 1 kV and up to and including 52 kV*. Geneva, Switzerland International Electrotechnical Commission
- [3] IEC 62271 – 203. *High-voltage switchgear and controlgear - Part 203: Gas-insulated metal-enclosed switchgear for rated voltages above 52 kV*. Geneva, Switzerland International Electrotechnical Commission
- [4] IEC 60044 – 7. *Instrument transformers - Part 7: Electronic voltage transformers*. Geneva, Switzerland International Electrotechnical Commission
- [5] IEC 60044 – 8. *Instrument transformers - Part 8: Electronic current transformers*. Geneva, Switzerland International Electrotechnical Commission
- [6] IEC 61850 – 1. *Communication networks and systems for power utility automation - Part 1: Introduction and overview*. Geneva, Switzerland International Electrotechnical Commission
- [7] IEC 61850 – 9 – 2. *Specific communication Service Mapping – Sampled values over ISO/IEC 8802-3. Second edition*. Geneva, Switzerland International Electrotechnical Commission
- [8] 1MRS7557959. *ABB Distribution Automation Handbook*. ABB Oy, Medium Voltage Products, Finland
- [9] CA08104001E. *Eaton Power Distribution System*. Eaton Inc, USA
- [10] AMTED300014EN. *Medium voltage technical guide*. Schneider Electric Industries SAS, France
- [11] STEFANKA, M.; PROKOP, V.; SLAGE, G. Application of IEC 61850-9-2 in MV switchgear with sensors use. CIRED 2013 - 22nd International Conference on Electricity Distribution in Stockholm, Sweden

- [12] Sun, X.; Redfern, M.A. *Implementation of the IEC 61850 9-2 Process Bus used for Protection Systems in the Digital Substation*. Electric Power Engineering 2012. Brno, Czech Republic
- [13] Juvik, J.I. *A Calibration System for Instrument Transformers with Digital Output*. Technical report no 385L. Department of Electric Power Engineering. Goteborg, Sweden.
- [14] C37.235. *IEEE Guide for the Application of Rogowski Coils Used for Protective Relaying Purposes*. IEEE Power Engineering Society. New York, NY, USA
- [15] CHATREFOU, D. *Interoperability field experiments in substations using IEC 61850-9.2 with Non-Conventional Instruments Transformers and all secondary equipment*. CIGRE SC A3 & B3. Joint Colloquium, Tokyo, Japan
- [16] Report no. 100803ID638VER27. *Protection requirements on transient response of voltage and current digital acquisition chain*. CIGRE Working Group B5.24.
- [17] Kaczkowski, A.; Knoth, W. *Combined sensors for current and voltage are ready for application in GIS*. F-75008, CIGRE session in Paris, France
- [18] Teyssandier, Ch. *From current transformers to hybrid sensors in HV*. Cahier technique Merlin Gerin #170. Grenoble, France
- [19] Hou, D.; Dolezilek, D. *IEC 61850 – What it can and cannot offer to traditional protection schemes*. 20080912 • TP6335-0. Schweitzer Engineering Laboratories, Inc.
- [20] Andersson, L.; Brand, K-P. Brunner, Ch.; *Reliability investigations for SA communication architectures based on IEC 61850*. Paper # 604. 2005 IEEE St. Petersburg PowerTech. St. Petersburg, Russia
- [21] IEC TR 61850-90-4: 2013. *Communication networks and systems for power utility automation - Part 90-4: Network engineering guidelines*. Geneva, Switzerland International Electrotechnical Commission
- [22] IEC 62439-3:2012. *Industrial communication networks - High availability automation networks - Part 3: Parallel Redundancy Protocol (PRP) and High-availability Seamless Redundancy (HSR)*. Geneva, Switzerland International Electrotechnical Commission
- [23] Javora, R.; Prokop, V. *Low-Power current and voltage sensors for MV Applications*. OMICRON electronics 2011 – IPTS

- [24] IEC 61850 – 8 – 1. Specific Communication Service Mapping (SCSM) – Mappings to MMS (ISO 9506-1 and ISO 9506-2) and to ISO/IEC 8802-3 Second edition. Geneva, Switzerland International Electrotechnical Commission

LIST OF PUBLICATIONS, ARTICLES and PATENTS

- [1] ŠTEFANKA, M. More than you can expect. *In IEC 61850 Global standards IEC 61850 and IEC 61400-25 widely accepted New perspectives in utility integration and automation*. Praxis Profiline. Vogel business media, Germany. ISBN 3-8259-1945-5
- [2] ŠTEFANKA, M. Communications Networks and Systems in Substations (IEC 61850). *In IEEE Switchgear Committee Meeting, Philadelphia, USA, 18 October 2007*
- [3] JAVORA, R.; ŠTEFANKA, M.; MANONEN, P.; NIEMI, T.; RINTAMAKI, O. Protection in MV networks using electronic instrument transformer. *In CIGRE 2009 - 20th International Conference on Electricity Distribution, Prague, Czech Republic, 8-11 June 2009*, Stevenage Hertfordshire: IET Service Ltd, 2009. pp. 1-4. ISBN: 978-1-84919-126-5
- [4] GRANHAUG, O.; ISAKSEN, K.; MEKIC, F.; HOLMLUND, J.; ŠTEFANKA, M.; Compact secondary substation in a future medium voltage distribution network. *In CIGRE 2011 - 21st International Conference on Electricity Distribution, Frankfurt, Germany, 6-9 June 2011*, pp. 1-4.
- [5] ŠTEFANKA, M.; PROKOP, V.; SALGE, G. Application of IEC 61850-9-2 in MV switchgear with sensors use. *In CIGRE 2013 - 22nd International Conference on Electricity Distribution, Stockholm, Sweden, 10-13 June 2013*, Stevenage Hertfordshire: IET Service Ltd, 2013. pp. 1-4. ISBN: 978-1-84919-732-8.
- [6] ŠTEFANKA, M.; PARE, D.; *US-15010 Improved outdoor enclosure for power distribution equipment*. USA, Patent application, 2 September 2015, – in progress
- [7] ŠTEFANKA, M. The Parallel Redundancy Protocol over Wide Area Networks Smart Grid and Renewable Energy (SGRE), 2016, ISSN 2151-4844 – in progress
- [8] J. STARCK, A. HAKALA-RANTA, M. ŠTEFANKA, 2012: "Switchgear Optimization Using IEC 61850-9-2 and Non-Conventional Measurements", PAC World Conference, Budapest.