



# BRNO UNIVERSITY OF TECHNOLOGY

VYSOKÉ UČENÍ TECHNICKÉ V BRNĚ

FACULTY OF MECHANICAL ENGINEERING  
FAKULTA STROJNÍHO INŽENÝRSTVÍ

ENERGY INSTITUTE  
ENERGETICKÝ ÚSTAV

## EXPANSION VALVE REPLACING WITH THE CAPILLARY TUBE

NÁHRADA EXPANZNÍHO VENTILU KAPILÁRNÍ TRUBICÍ

MASTER'S THESIS  
DIPLOMOVÁ PRÁCE

AUTHOR  
AUTOR PRÁCE

Bc. Viktor Devečka

SUPERVISOR  
VEDOUCÍ PRÁCE

Ing. Jiří Hejčík, Ph.D.

BRNO 2016

---



## Zadání diplomové práce

Ústav: Energetický ústav  
Student: **Bc. Viktor Devečka**  
Studijní program: Strojní inženýrství  
Studijní obor: Technika prostředí  
Vedoucí práce: **Ing. Jiří Hejčík, Ph.D.**  
Akademický rok: 2015/16

Ředitel ústavu Vám v souladu se zákonem č. 111/1998 o vysokých školách a se Studijním a zkušebním řádem VUT v Brně určuje následující téma diplomové práce:

### Náhrada expanzního ventilu kapilární trubící

#### **Stručná charakteristika problematiky úkolu:**

Současná tepelná čerpadla jsou schopna dosahovat vysokých účinností díky sofistikovanému elektronickému systému řízení. Komponenty pro elektronické řízení jsou však nákladné, což přináší konkurenční nevýhodu v případě cenově orientovaného zákazníka. Prostá náhrada elektronické součástky za levnější mechanickou však není vždy jednoduchá a často vede ke zhoršení výkonových parametrů zařízení.

#### **Cíle diplomové práce:**

Cílem práce je provést náhradu elektronického expanzního ventilu za kapilární trubici tak, aby bylo dosahováno požadované úrovně podchlazení.

#### **Seznam literatury:**

- Dinçer, I. (2003): Refrigeration systems and applications. Wiley, Chichester.
- Žeravík, A. (2003): Stavíme tepelné čerpadlo: [návratnost i za jeden rok]. Antonín Žeravík, Přerov
- Kolektiv autorů (2012): Chladicí a klimatizační technika. Svaz chladicí a klimatizační techniky, Praha.

Termín odevzdání diplomové práce je stanoven časovým plánem akademického roku 2015/16.

V Brně, dne 27. 10. 2015



doc. Ing. Jiří Pospíšil, Ph.D.

ředitel

doc. Ing. Jaroslav Katolický, Ph.D.

děkan

---

## Abstract

Great importance is placed at present on the reduction of emission production quality and purity of the environment. These trends apply to all industries, as well as the construction industry and heating of buildings. Until now, the most widely used type of heating was combustion of fossil fuels. Heat pumps, however, are coming to prominence and are beginning to take a significant share of the market. Because of the demand for heat pumps, the number of producers and competition is increasing. The aim of manufacturers is to increase the efficiency of heat pumps and at the same time reducing production costs to achieve a better position in the market.

This paper deals with the processes occurring in the refrigerant circuit of the heat pump. It examines the behaviour of refrigerant during condensation and ways to increase efficiency of the heat pump. Increasing efficiency is achieved by chilling the refrigerant during condensation to increase the heat gain. This is achieved by including a second electronic expansion valve behind the condenser. This technology is, however, costly. The thesis deals with the calculation of the capillary based on practical measurement, which will retain refrigerant in the condenser and will perform a similar role as the expansion valve. Subsequently the results of individual measurements are compared. The results are compared to a simple system in which there is no refrigerant hypothermia. The analysis of the results of the various systems is in conclusion.

## Key words

Electronic expansion valve, capillary, pressure drop, heat pump, refrigerant, sub-cooling of refrigerant, condenser, condensation, compressor, heating capacity, COP

## Abstrakt

V súčasnosti sa kladie veľký dôraz na znižovanie produkcie emisií, čistotu a kvalitu životného prostredia. Tieto trendy sa týkajú všetkých odvetví, tak isto aj stavebného priemyslu a vykurovania budov. Doposiaľ bolo najrozšírenejším typom vykurovania spaľovanie fosílnych palív. Do popredia sa však dostávajú tepelné čerpadlá a začínajú zaberat' výrazný podiel trhu. Kvôli dopytu po tepelných čerpadlách vzrastá počet výrobcov a konkurencia. Cieľom výrobcov je zvyšovanie účinnosti tepelných čerpadiel a zároveň znižovanie výrobných nákladov na dosiahnutie lepšej pozície na trhu.

Predložená práca sa zaoberá procesmi prebiehajúcimi v chladivovom okruhu tepelného čerpadla. Skúma správanie chladiva počas kondenzácie a možnosti zvýšenia účinnosti tepelného čerpadla. Zvýšenie účinnosti je dosiahnuté podchladením chladiva počas kondenzácie na zvýšenie tepelných ziskov. To je dosiahnuté zaradením druhého elektronického expanzného ventilu za kondenzátorom. Táto technológia je však finančne náročná. Práca sa zaoberá výpočtom kapiláry na základe praktických meraní, ktorá bude zadržiavať chladivo v kondenzátore a bude plniť podobnú úlohu ako expanzný ventil. Následne sú porovnané výsledky jednotlivých meraní. Výsledky sú porovnané voči jednoduchému systému, kde nedochádza k podchladeniu chladiva. V závere práce je analýza výsledkov jednotlivých systémov.

## Klíčové slová

elektronický expanzný ventil, kapilára, tlaková strata, tepelné čerpadlo, chladivo, podchladenie chladiva, kondenzátor, kondenzácia, kompresor, vykurovací výkon, COP

---

### **Bibliographic citation**

DEVEČKA, V. *Expansion valve replacing with the capillary tube*. Brno: Brno University of Technology, Faculty of Mechanical Engineering, Energy Institute, 2016 64p. Supervisor of diploma thesis Ing. Jiří Hejčík, Ph.D..

---

## **Declaration**

I declare that this thesis on Expansion Valve Replacing with the capillary tube is my own, unaided work. The applied literature is properly quoted and all sources are stated in the reference list.

Date:

.....  
Viktor Devečka

---

## **Acknowledgments**

I would like to thank this way to Ing. Jiří Hejčík Ph.D. for a friendly approach and valuable comments and advices in drafting the thesis.

I would also like to thank to Ing. Christoph Bacher, Ing. Paul Sumerauer and Ing. Christian Gritzer for the opportunity to work on this project.



---

## Table of contents

1	Introduction .....	11
2	Targets and limits of diploma thesis:.....	12
2.1	Targets of thesis .....	12
2.2	Limits of thesis.....	12
3	Heat preparation, heating.....	13
3.1	Furnaces .....	13
3.2	Electrical heating .....	14
3.3	Solar collectors .....	14
4	Heat pumps .....	15
4.1	The most important terms .....	15
4.2	Parts of heat pump.....	17
4.2.1	Heat exchangers .....	17
4.2.2	Compressor.....	20
4.2.3	Expansion valve .....	22
4.2.4	Refrigerants .....	23
4.2.5	Another parts of heat pump.....	25
4.3	Types of heat pumps .....	28
4.3.1	Air source heat pumps.....	28
4.3.2	Water source heat pumps.....	29
4.3.3	Brine source Heat pumps .....	29
5	Tests and calculations .....	30
5.1	Using sub-cooling for increasing performance of HP.....	30
5.1.1	Idea of using the capillary.....	31
5.2	Heat pump tests .....	31
5.2.1	Tested Heat Pump .....	31
5.2.2	Test bench .....	32
5.2.3	Rating test with electronic expansion valve.....	34
5.3	Calculation of capillary .....	37
5.3.1	Demanded data for calculation .....	37
5.3.2	Selection of the capillary .....	40
5.3.3	Capillary's pressure drop calculation .....	44
5.4	Rating test with capillary and with pipe.....	49
5.4.1	Rating test with capillary .....	49
5.4.2	Comparison of calculated and measurer pressure drop.....	50

---

5.4.3	Rating test with pipe .....	51
6	Evaluation of the measured results .....	53
6.1	Main characteristics comparison of different types of sub-cooling .....	53
6.1.1	Heating capacities comparison .....	53
6.1.2	Electric consumptions comparison .....	55
6.1.3	Sub-cooling comparison.....	55
6.1.4	COP's comparison .....	56
6.2	Discussion.....	57
6.2.1	Electronic Expansion valve.....	58
6.2.2	Capillary.....	58
6.2.3	Pipe, zero sub-cooling .....	58
7	Conclusion .....	60
	List of sources .....	61
	List of symbols.....	62
	List of pictures .....	63
	List of graphs .....	63
	List of tables.....	64



---

## 1 Introduction

Heating and hot water preparation are one of the most important for the comfortable environment in interior spaces in location middle and northern Europe. Nowadays different possible ways are available, how to provide heat and hot water preparation for houses, public buildings and also for different applications. Basic and still most widely used methods are furnaces which are burning fossil fuels. These are available in a wide range of heating powers, so they can cover the whole range of heating demands. Furnaces also are fully regulated in heating power and depend just on supplies of the fuel. Big disadvantages of furnaces are in the production of emissions that comes with the burning process and dependence on fossil fuels that are on the earth in limited amount. Those are the main reasons why the development in heat preparation is also focused on the green and ecological ways.

Green production of the heat means producing as less emissions as it is possible. We are looking for renewable sources such as bio-mass, sun energy, geothermal energy or low potential sources. Solar collectors, photovoltaic panels are becoming more available. But the main problem with this is that they depend on sunny days.

One of the most flexible means that bring comfort are also Heat Pumps. In the last years they have become more popular for heating and not only for family houses or small applications. With improved heating capacities and COP heat pumps are nowadays more competitive with classic applications for heating, such as gas, oil, electrical heater. Also improved regulation that is mostly referred as SMART is increasing comfort with decreasing costs needed for producing heat. Even though heat pumps produce zero emissions during running, refrigerant which they use can harm the environment in case of a leak. That is the reason why European Union is reducing refrigerant that have the biggest impact to environment and development by publishing new regulations and norms and towards the more ecological refrigerants. Older refrigerants contain chlorofluorocarbon known like freons, which have an impact to global warming and environment. Disadvantage of new refrigerants are different points of operation. It is necessary to design new components of heating circuit because of this. Competition between heat pump productions and limits in using of refrigerant brings new technical features and solutions of how to be the best on the market.

My diploma thesis is focused on increasing heating capacity and COP of the heat pump. I am going to study behavior of the refrigerant circuit during the rating test. My development focuses on measurements of the heat pump efficiency, which has controlled sub-cooling of the refrigerant behind the condenser with another electrically regulated expansion valve. Subsequently, I am going to design capillary that provide pressure drop behind the condenser and provide sub-cooling of refrigerant in the same way like expansion valve. I am going to test this capillary and energy gain of sub-cooling in refrigerant circuit and the stability of the refrigerant circuit in starting conditions. Comparisons of gains of sub-cooling and two different ways in providing of sub-cooling are on the end.

---

## 2 Targets and limits of diploma thesis:

### 2.1 Targets of thesis

- Description of heat pumps and the refrigerant circuits.
- Specification of sub-cooling advantages in the refrigeration circuit of heat pump.
- Measurement of the heat pump with different sub-cooling element inserted.
- Calculation of the capillary for replacing electronic expansion valve causing sub-cooling.
- Comparison of the effect of sub-cooling of refrigerant on the condenser side in the refrigerant circuit in the heat pump with two different pressure drop elements.

### 2.2 Limits of thesis

- In the thesis are not going to be compared different refrigerants. That could have caused different conditions of evaporation and mainly condensation in the circuit.
- The tests are not going to be executed with different compressor installed. Because different compressor also with the same working volume would have had different behavior in edge conditions and in starting sequence also with the same components in the refrigerant circuit.
- The whole tests are going to be done with the same heat pump with the same refrigerant filling, to secure best possible comparison of different variants in the rating test.

---

### 3 Heat preparation, heating

In the climate conditions with middle and cold temperatures it is necessary to provide heating and hot water preparation for comfortable living. For heat preparation are the most often used furnaces, electrical heaters, solar collectors and heat pumps. Instead of electrical heaters which are mainly used for local heating, all other possibilities are mainly provided as central heat preparation. Heat is distributed from the source to the place of consumption and is delivered by water, steam or air.

#### 3.1 Furnaces

Basic and still most widely used methods for the heat preparation are fossil fuels combusting furnaces. This category includes coal, oil, wood, bio-mass and gas burning furnaces. These systems are based on the same principle. Fuel is delivered to the combustion chamber where it's fired from surrounding already burning fuel. The heat energy release from fuel during the burning process is absorbed by heat transferring medium in the heat exchanger or boiler above the combustion chamber. After this, medium is delivering heat to the place where it is required. This medium is mostly water, but still widely used are also steam and air in some applications where it is needed. Furnaces are one of the cheapest ways of heat preparation also because of low prices of furnaces compared to heat pumps. They are widely used because of easy regulation in wide range and depend only on the fuel supplies, which are easy to provide.

Anyway, bio-mass and gas furnaces are considered as clean ways of heat preparation. Bio-mass furnaces are also considered as renewable source heat preparation. Heat preparation in all furnaces is delivered by burning process, which is still accompanied by exhaust and emission production, which effect environment and in solid fuel furnaces is also accompanied by production of ashes. [1], [2]



Picture 3.1: Gas furnace and pellet furnace for heating buildings

---

### 3.2 Electrical heating

Electric heating systems that use for the heat preparation electric resistant elements, are very comfortable to use and easy to regulate. These systems also produce no emissions in the place of consumption. But also nowadays big amount of electrical energy is produced by thermal power stations, which are powered by coal or gas, rather than nuclear power plants or big hydroelectric power stations. None of these come under green way of energy production and they have a big impact to the environment where they are placed. There are also green ways of electricity production, such as wind propelled power stations, photovoltaic power plant and other different experimental ways of electricity production. But anyway, electric heating is the most expensive heat preparation and including power losses in the electrical distribution grid also the least efficient way of heat preparation. Those are the reasons why this system is the last choice. [1]



Picture 3.2: Local electrical heater

### 3.3 Solar collectors

Solar collectors collect sun's energy and carry it to the transferring medium that is stored in buffers and when the heat is needed, the buffer is used as a source of heat. It is necessary because time of heat preparation does not fit with the times of demands. Solar collectors have good efficiency and are really ecological forms of heat and hot water preparation. But on the other hand, they require maintenance and are limited by the place where they can be used. It depends on the position of the house and average number of sunny days in the year. It is also necessary to have a back-up heating system in case there are not enough sunny days. [2]



Picture 3.3: Solar collector for hot water preparation

---

## 4 Heat pumps

Heat pumps use the refrigerant circuit for heat preparation. Naturally, energy always flows from a higher to lower potential. Heat pumps work in the opposite direction. They are technical devices that take heat from low potential temperature sources, which is not possible to use otherwise, and make heat of high temperatures that can be used in demanded applications such as heating a buildings or hot water preparation. Thanks to high and low pressure side of the circuit provided by the compressor and expansion valve they pump heat from the source that has low temperatures to the heating circuit. Compressor pumps gas refrigerant from the evaporator to the condenser and increases the pressure of refrigerant. Thanks to this, refrigerant is able to condensate in high temperatures and release heat to the transferring medium. Expansion valve provides a pressure drop and choke of liquid refrigerant between condenser and evaporator. Wet steam of choked refrigerant is able to evaporate in low temperatures and takes away heat from the source medium and transforms to a gaseous state. After this is refrigerant sucked by the compressor again. Heat pumps can be placed and used the same way as furnaces, but it is necessary to provide a connection to the source medium. Four different sources can be used: air, water and ground heat or also heat from solar collectors. Thanks to good regulation they do not need more maintenance than classic furnaces. Heat pumps are not dependant on fuel supplies, just on the electric supplies, but all modern furnaces depend also on electricity and are not able to run without it. But heat pumps consume more electricity for running compressors and circulation pumps or ventilators than furnaces. An index that shows energy needed for running heat pump and energy gained from a heat pump called COP. For example, when COP is equal to 3, from 1 kW, which heat pump consume, it produces 3 kW of heat. The heat pump is more expensive for entry investments. However, during running, it is one of the cheapest ways of the heat production. To better understand how heat pumps work it is necessary to explain terms and expressions connected with heat pumps and refrigerant circuit that is built in the heat pumps. [3], [4]

### 4.1 The most important terms

#### Low potential heat source

It is a medium which has low temperatures, but it occurs in big amounts. It is not possible to use heat energy of this medium. This medium is the source of the heat for heat pumps. The most often it is water, brine or air. [4]

#### Coefficient of Performance COP

Or heating factor is a dimensionless number, which indicates the ratio of heating power output to power input in electrical energy that a heat pump consumes to produce heating power at a standardised working point. This number is always higher than 1. But usually for heat pumps the COP lies within the range of 2 to 6 and depends on operating point of the heat pump. In practice, if COP is lower than 2 or 2,5, it is better to start with bivalence heat preparation. This number depends on the region or country where the heat pump is installed. [3]

#### Real COP

It is also a dimensionless number that includes power input of all devices necessary for running heating circuit such as pumps for circulation, ventilators and



---

regulation. This number is still higher than 1 but more factors on the power input site show us that it has to be lower than COP. [3]

### Bivalent operation

Providing heating energy with two different heating systems is called bivalent operation. In heat pumps it is most often additional electric heater. It is used in point when the power output of a heat pump is not able to supply enough energy. Opposite of bivalence is monovalent, it means that heat pumps supply whole heating demands.[4]

### Point of bivalence

It is outside temperature, at which heat losses of the heated building are in the equation with a maximum heating capacity of the heat pump. When the outside temperature falls below this temperature, it is necessary to turn on additional source of energy and the heat pump starts to run in bivalent mode. [3]

### Monovalent

This is an operation mode when the heat pump is only heat delivery system to a heating appliance. Heat pumps should run in this mode for the longest part of their running time. So the energy saving of heating is the biggest and heat pumps cover heat losses for most of the time. [4]

### Seasonal performance factor SCOP

The seasonal performance factor describes the ration of the amount of the heating power submitted by the heat pump over the whole year and the amount of electrical energy consumed in providing the heating power during that period. Therefore it reflects the rate of use of the heat pump equipment. [4]

### Nominal outdoor temperature

It is the lowest mean-value of two days of the air temperature at a location that is reached or fallen below 10 times in 20 years. This temperature is used in the calculation of heat losses of the building. Based on calculated heat losses is chosen heat pump with heating capacity that covers losses of the building. [4]

### Heat losses

This value is calculated for every building, according to nominal outdoor temperature. To ensure the comfort of living, it is necessary to choose heating equipment with power output that can cover heat losses of the building. [4]

### Global warming potential (GWP)

GWP is the characteristic number of each refrigerant that specifies the impact of released refrigerant to the environment compared with CO<sub>2</sub>. It shows how many kilograms of CO<sub>2</sub> refer to 1 kilogram of refrigerant with impact to global warming. [3]

### Pressure drop

It is a pressure decrease of fluid medium after passing controlled area. Dependence of pressure drop in controlled area is not linear and is often presented by a

---

graph or chart. It is the important characteristic number of heat exchangers in the circuit. Pressure drop is also provided by the expansion valve in front of the evaporator.

### Brine

It is the universal name of anti-freeze mixture. Brine is a mixture of water and an anti-freeze and is used as heat carrier in heat pumps that use geothermal energy source. [4]

## 4.2 Parts of heat pump

Heat pumps are quite complicated equipment in comparison with different heating systems. Heating circuit is in other words switched cooling circuit that is normally used in fridges or air conditioning systems. Parts are adapted to different use and different operation points. Because of high pressure in the circuit it is necessary to provide safety and tightness of whole circuit and connections. All parts have to be tested and proved on the highest allowed pressure.

### 4.2.1 Heat exchangers

Heat exchangers are construction parts that provide heat transfer between two different mediums. During the heat changing in exchanger those mediums can't be in physical contact or mixed. For heat exchangers is valid second law of thermodynamic. Simplified expression: *Heat flow only passes through environs with higher temperature to the environs with lower temperature.* There has to be always temperature difference between these two mediums.

Heat exchanger in heat pump is used at first for extracting of the heat from the outer environment to the refrigerant circuit. After this the heat in another heat exchanger transfers to the water heating circuit. According to usage, heat exchangers are divided to evaporators and condensers.

For the heat exchangers is main characteristic factor of power size of the contact surface which allows heat transfer between mediums.

Another important characteristic is pressure loss of overflowed medium. This pressure loss depends on the construction of the heat exchanger and on mass flow through exchanger and it isn't a linear function which is expressed by a graph. In the heat pumps are mainly used two different construction types of heat exchangers: plate, lamella and pipe exchangers. [3], [5]

#### Plate heat exchangers

Plate heat exchangers consist of stainless steel sheets, which are specially molded in the press machine. Sheets are created after assembling two divided channels. Through these channels mediums flow separately. Sheets are welded together, so the whole heat exchanger is one compact piece and it can stand high process pressures. Exchangers have to be tested in high pressures. Plate exchangers in heat pumps consist sometimes from 30 sheets, so it is necessary to have at the inlet distributors for equal spreading of refrigerant. Plate heat exchangers have high effectiveness and high heat transfer in small dimensions. They are compact, chemical resistant and easy to isolate. Disadvantages are high pressure drop and they can be clogged with dirt in primary circuits.

---

These exchangers are used like condensers and evaporators in water and brine source heat pumps. [5]



Picture 4.1: Plate heat exchanger

### Lamella heat exchangers

Lamella heat exchangers consist of one, but more often, more rows of copper pipes. Pipes are crossing aluminum lamellas for increasing the heat transferring surface. When a heat exchanger is used as evaporator then it is necessary to ensure equable distribution of the refrigerant at the outlet from expansion valve. When a heat exchanger is used as condensed, distribution is not needed. Lamella heat exchangers are used only in air source heat pumps like evaporators. [6]

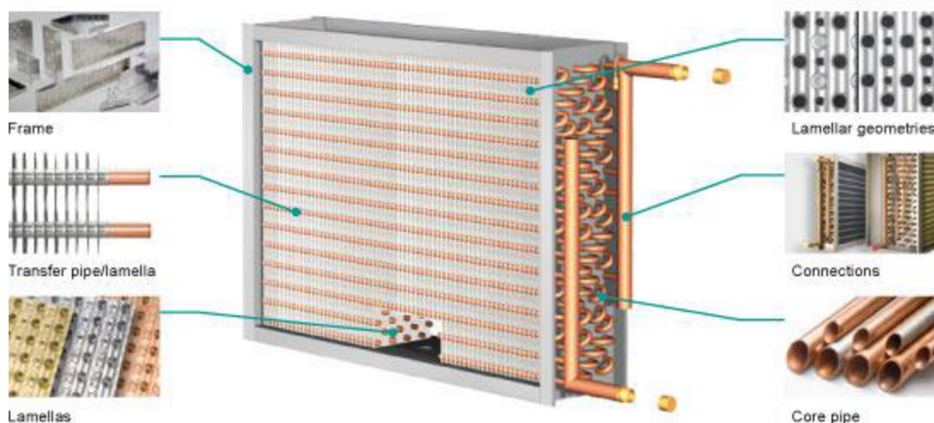

Picture 4.2: Lamella heat exchanger with description

**Pipe heat exchangers** are used in brine source heat pumps like external heat exchangers which are placed in drills or in area collectors in the ground for heat transfer between ground and brine.

### Condenser

Condenser is a specific type of heat exchanger, which is used like a heating element of refrigerant circuit. Inside comes to contact heating water on one side and with hot gasses refrigerant on the other side. Condensation of refrigerant is in process in condenser. It means that steams of hot refrigerant which are compressed to the high pressure at the outlet of compressor come to liquid state thanks to contact with colder water on the other side of the condenser. Thanks to state change preformed in the



condenser, latent heat is released from the refrigerant. Latent heat needed for state change is much higher than the measured heat capacity of the refrigerant. It means we are able to use more effectively the lesser amount of refrigerant. The condenser is exposed to high temperatures and pressures of hot refrigerant. After the condensation of the refrigerant, it is possible to get more heat from the refrigerant by sub-cooling. It is necessary to place a condenser in vertical position with the inlet at the top and the outlet at the bottom to allow drops of condensate refrigerant flow down thanks to gravitation. At the bottom, it can be sucked back to the circuit. Sub-cooling increases efficiency of the whole circuit. I am going to study this theme in further parts of my diploma thesis. [5]

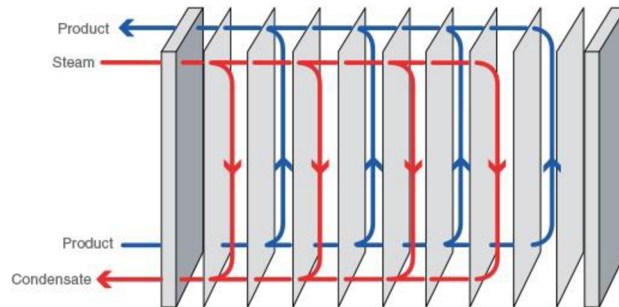

Picture 4.3: Condenser function

### Evaporator

Evaporator is used like a source of heat in the heating circuit. Inside comes into the contact source mass of the heat pump, which can be air, water or brine with wet steams of refrigerant on the other side. Liquid refrigerant of the high pressure passes through the expansion valve. Pressure of refrigerant is reduced in expansion valve by choking off to demanded value. Refrigerant becomes wet steam with low pressure and according to this with low temperature. Wet steams of refrigerant evaporate after contact with the source medium in the evaporator. During the evaporation is heat transferred from the source medium to the refrigerant. After this process the steams of refrigerant are sucked in by the compressor. Super heat of the refrigerant is unwanted, because it decreases the efficiency of the circuit and the compressor has more work to do, to compress the refrigerant to the high pressure. But on the other side, some super heat is necessary for steady work of the whole circuit. It also prevents the entry of not fully evaporated steams to the compressor. Little drops of liquid at the inlet to the compressor can harm the compressor what decreases the whole lifetime of the heat pump. Also, because of this are inlets to the evaporator placed mainly on the bottom of the evaporator and an outlet on the top of the evaporator. [5]

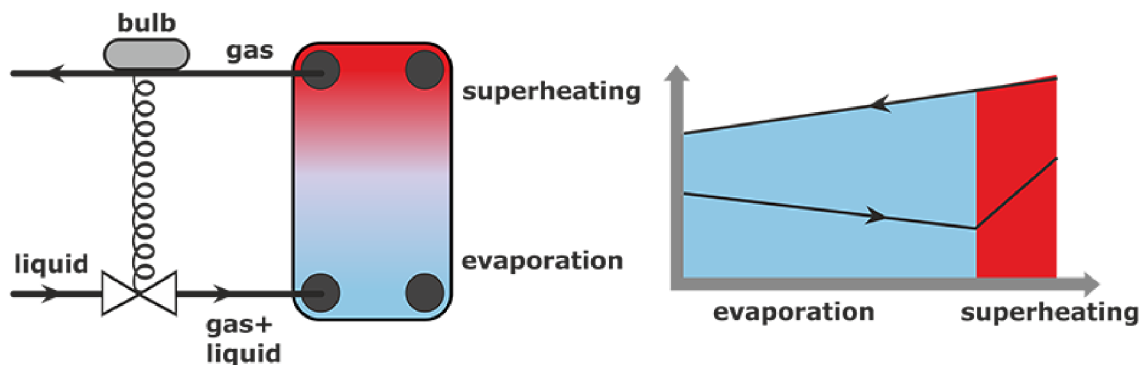

Picture 4.4: Evaporator function with connection

---

## 4.2.2 Compressor

The compressor is an element of the refrigerant circuit that initiates the motion of refrigerant. In heat pump, it's used to compress the steams of refrigerant which are created in the evaporator. Compressor increases the pressure of the steams what is causing the increase of the temperature. A product of the compressor is hot gas of the refrigerant which is pushed to the condenser, where it releases the heat absorbed in the evaporator. Pressures in suction and output pipe depend on the used type of refrigerant and on working points of the refrigerant circuit. Normal range of sucking pressures is 0,1 – 0,5 MPa. Output pressures are in the range of 1 – 3 MPa. The compressor itself can provide higher pressures, but it has implemented safety items which are protecting machine against increasing of the pressure over the limits of the circuit. The ratio of suction and outlet pressures is called Compression ratio.

Temperatures of the sucked steams are approximately in the range from -20°C to +10°C. Temperatures of the compressed hog gas are in the range of 60-100°C.

The important parameter of the compressor that doesn't depend on the type of the compressor or the refrigerant is suction power or suction volume. It is given in [m<sup>3</sup>/hour] of sucked gas. It's the volume of sucked steams according to pressure in the suction pipe. From the characteristics of the refrigerant and so-called volumetric cooling ability indicated in [J / (m<sup>3</sup>\*K)], is possible to define the total cooling power of the compressor and from this the volume of pumped refrigerant. Compressors are divided into the different categories according to the construction, the way how gas is pumped and the tightness of the whole unit. [3]

Dividing according to tightness:

Hermetic settlement of the compressor has on one axle and in one box compressor and electric engine. Oil filling is also common and united. The advantage is the total tightness because this box has only inlet and outlet opening for the refrigerant. There is no possibility of the leak of refrigerant through the connections.

Semi hermetic settlement is when compressor and motor are also closed in a hermetic case. But on the case is a tight removable cover for service and maintenance. Those compressors are piston and they are used for bigger capacities.

Open settlement is just compressor itself. Its axle is sealed up against refrigerant leak and the axle is coming out of the box. The compressor can be driven by various types of the engines. This type of compressors is used nowadays in cars for example. [6]

### Piston compressors

Piston hermetic compressors are most widely used in small applications as fridges. They are produced for a very long time what means their construction is at high level and quality. Piston compressors in fridges have a long lifetime, sometimes over 20 years. Electromotor is cooled by steams of refrigerant and oil filling is united. The disadvantage of these compressors is that the wet steams in suction always harm them. So there have to be safety items implemented.

In piston compressors it doesn't matter on the direction of rotation. But piston compressor is always louder than scroll compressors and depending on the pressure difference in suction and outlet, dead space is increasing. [6]

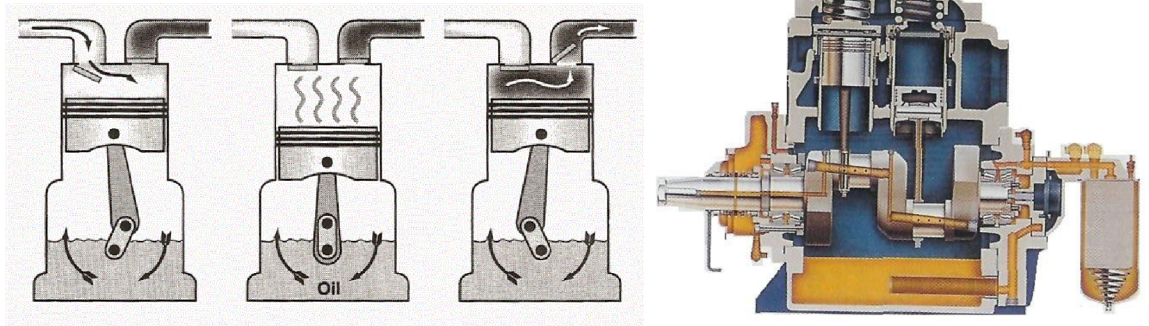

Picture 4.5: Piston compressor

### Scroll compressors

Spiral or scroll compressors are widely used in heat pumps. They consist of two metal spirals inserted in each other. Upper spiral is fixed and has an opening on the top connected to an outlet. Lower spiral doesn't twist. It makes an eccentric gyratory motion, thanks to eccentric connections with the motor's axle. Thanks to this motion between those spirals are areas that push the gas to the center with constantly increasing pressure. These compressors have higher prices, but also very long lifetime. The motor of the hermetic scroll compressor is also cooled by steams of refrigerant and oil filling is united. Advantages of scroll compressors are: volumetric efficiency can be 100% higher than piston compressors. Less vibrations are causing more silent running. Construction is simpler because there are less moving parts. The scroll compressors are resistant against wet steams or liquid refrigerant in suction. They have no valves, so there is no dead space.

The disadvantage is that the direction of the rotation has to be observed. Because of lubrication they have minimal running time and can't be run more than 6-times per hour. [6]

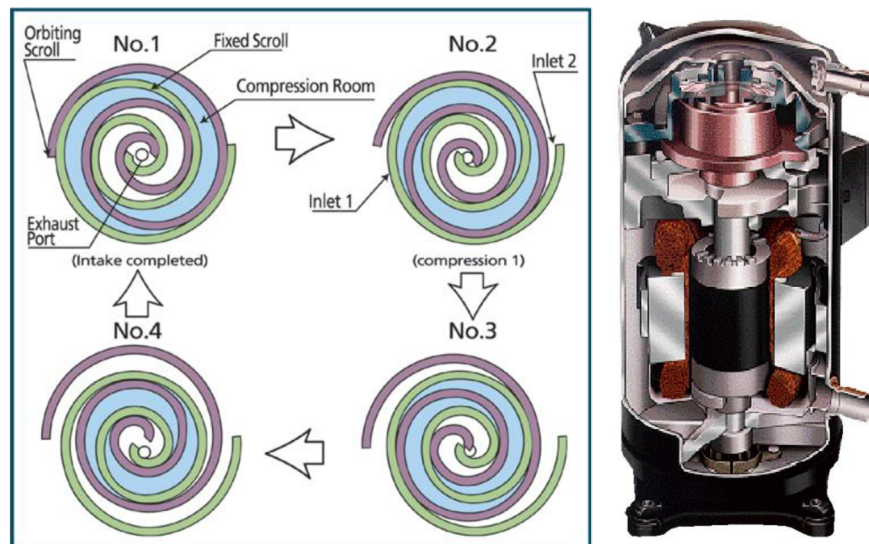

Picture 4.6: Scroll compressor

### Compressors with speed control

Nowadays the trends and also the regulations of the EU are pushing the heat pump producers to use the compressors with regulated speed. These compressors reach less COPs during running than on/off compressors but they are able to cover a wider range of



---

heating capacities. That means modulated machines have a better overall efficiency than on/off compressors. But modulated compressors need for running an inverter that is changing phases of the electricity supplies of the compressor and this changes compressor speed. Energy consumption of the inverter increases also overall consumption. But the advantage is that compressor doesn't have to work in discontinuous run and the overall result is better. Also less starting of the compressor prolongs lifetime of the heat pump. [4]

### 4.2.3 Expansion valve

Compressor, condenser, expansion valve and evaporator are four main parts of the heat pumps. Expansion valve is placed on the opposite side of the compressor. Its task is also opposite than the compressor's task. Expansion valve makes the pressure drop and it injects choked refrigerant to the evaporator. It also regulates the amount of injected refrigerant, because evaporator has to be filled properly and the whole refrigerant could be evaporated. Expansion valve takes care of optimal working conditions in the circuit. The construction of expansion valve is highly developed and changes between different producers are just in the details. Main parts of expansion valve are nozzle through which flows refrigerant and needle that is closing nozzle and regulates pressure drop to the demanded value. [6]

There are two different types of expansion valves in use:

#### Thermostatic expansion valve

Thermostatic expansion valves are used in simpler applications. They are fully mechanical also with regulation. The opening of this type of valve is provided by the membrane. The motion of the membrane is initiated by three different forces. The first is the force of the inlet pressure. The second is force of the spring with regulation screw for the adjusting. The third force is the pressure force from the control element. This element consists of the bulb filled with liquid or gas medium. The element is connected at the outlet of the evaporator and is heated by the steams of the refrigerant. At the principle of thermal expansion is pressure in the element increasing and decreasing. The element is connected by a capillary with expansion valve. When overheating of refrigerant is high, pressure in the element increase and valve becomes more open and pressure drop decreases. If overheating is low, the effect is opposite. [6]

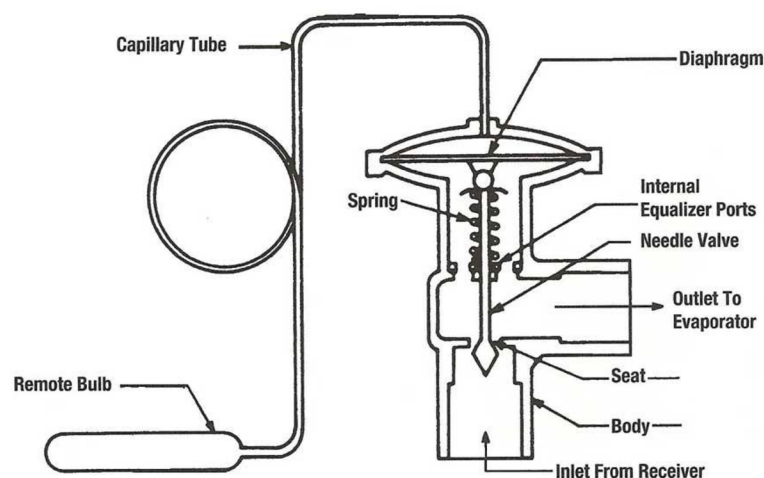

Picture 4.7: Thermostatic expansion valve

---

## Electronic expansion valve

This type of valve is nowadays used in the all types of heat pumps because of very good regulation. The difference is in the regulation of the needle. In the upper part of the expansion valve is some kind of rotor from the servo engine and it is wholly hermetically closed. At the top of the expansion valve is placed electrical coil, which has a construction like stator of the servo engine. Overheating of the refrigerant is measured by the thermometer sensor. Regulation of the expansion valve is provided by computer installed in the heat pump. Advantages of these valves are that they have a wide range of evaporation temperatures, they are self calibrating and can regulate different overheating. [6]

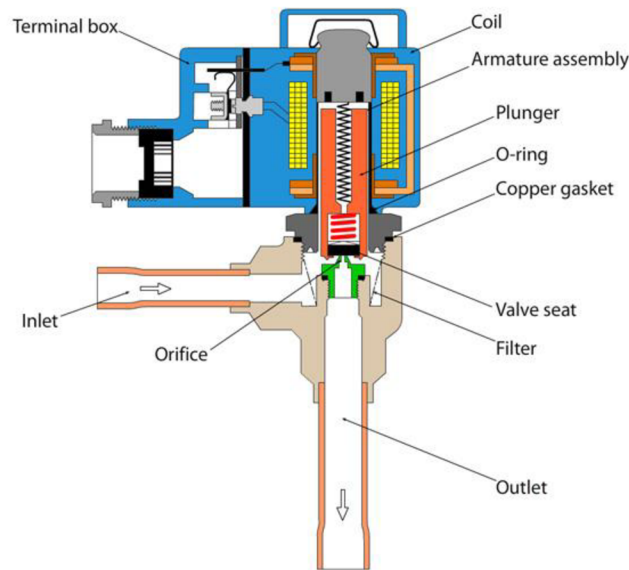

Picture 4.8: Electronic expansion valve

### 4.2.4 Refrigerants

The refrigerant is a carrier of the energy in the heat pump. Without this medium with special physical behaviour, the whole system shouldn't work. There are lots of various pipes of refrigerants, but for the heat pumps are appropriate only few of them. It could be one part clean compound or mixtures of two or more compounds. Refrigerants can be divided by different characteristic features.

The refrigerant divides according to the physical features. According to temperature behaviour and the proportion of the compounds it is possible to divide refrigerants to azeotropic and zeotropic.

**Azeotropic refrigerant** behaves like pure liquids. These refrigerants can be a mixture of more compounds. There are no changes during condensation of these refrigerants in the steam mixture. Examples of azeotropic refrigerants are R22, R290, or azeotropic mixtures are R502 and R507.

**Zeotropic refrigerants** are mixtures of 2 up to 4 different types of refrigerants, which have different behavior during the condensation. If saturated steam's temperatures of the mixtures are very close, then refrigerant is called near azeotropic. Zeotropic refrigerant is,

---

for example R 407a, but R404a is near azeotropic. Zeotropic refrigerants have specified temperature glide, which is different to the evaporation temperatures in same pressure. This difference can be few K but also dozens K.

#### ODP

Impact of gasses, steams and also refrigerants to the ozone layer is described by coefficient ODP (Ozone Depletion Potential). It is a relative number. It's based on freon R11 which has ODP coefficient equal to 1. With decreasing ODP number the impact to the ozone layer is lower.

#### GWP

The second coefficient, which specifies refrigerant's characteristic is GWP (Global Warming Potential). This value shows the impact of refrigerant to the greenhouse effect. In this number are counted also years of influence. The reference value is CO<sub>2</sub> / 100 years, which is equal to GWP = 1. Higher number means more negative impact.

#### Refrigerant dividing according to chemical composition

Refrigerants are divided into these chemical groups:

**CFC:** they are fully halogenated hydrocarbons and their mixtures without atoms of hydrogen. CFCs are also called "hard freons". This group has high ODP and GWP values. Examples: R11, R12, R13, R 114, R115, R502, R 503.

**HCFC:** these have in structure chlorine, fluorine and also atoms of hydrogen. They are also called "soft freons". ODP values are low and GWP values are in the middle range and high. Examples: R21, R22, R141b, R124.

**HFC:** these refrigerants don't include chlorine in structure, only fluorine. HFCs have ODP=0, but they have quite high coefficients of GWP. Examples: R134a, R152a, R32, R410a.

**HC:** are natural hydrocarbons without halogenides. ODP values are equal to 0 and GWP values are in the range from 0 to 20. But their disadvantage is that they are burnable. [3]

#### 4.2.4.1 Refrigerant R410a

This refrigerant is used in the heat pump which was used in measurement in this diploma thesis. It belongs to group HFC. R410a is a mixture of two refrigerants R32 / R125 in ratio 50/50% and it is used with POE oils. It is also known like Forene-410a, Solkane 410a, SUVA 9100.

Boiling point at atmospheric pressure is at -51,6 °C and temperature glide is approximately 0,1 K. That means it is a nearly azeotropic mixture. ODP = 0,00 ; GWP = 2340.

It is non-flammable, non-explosive, non-toxic refrigerant. Its thermodynamic features are similar like R22 or R407c but it has better cooling coefficient. The disadvantage of R410a is necessity of high pressures up to 4 MPa and it is necessary to use modified compressors and condensers. Thanks to high pressure systems that are using R410a can be smaller with the same heating capacity than others. [3]

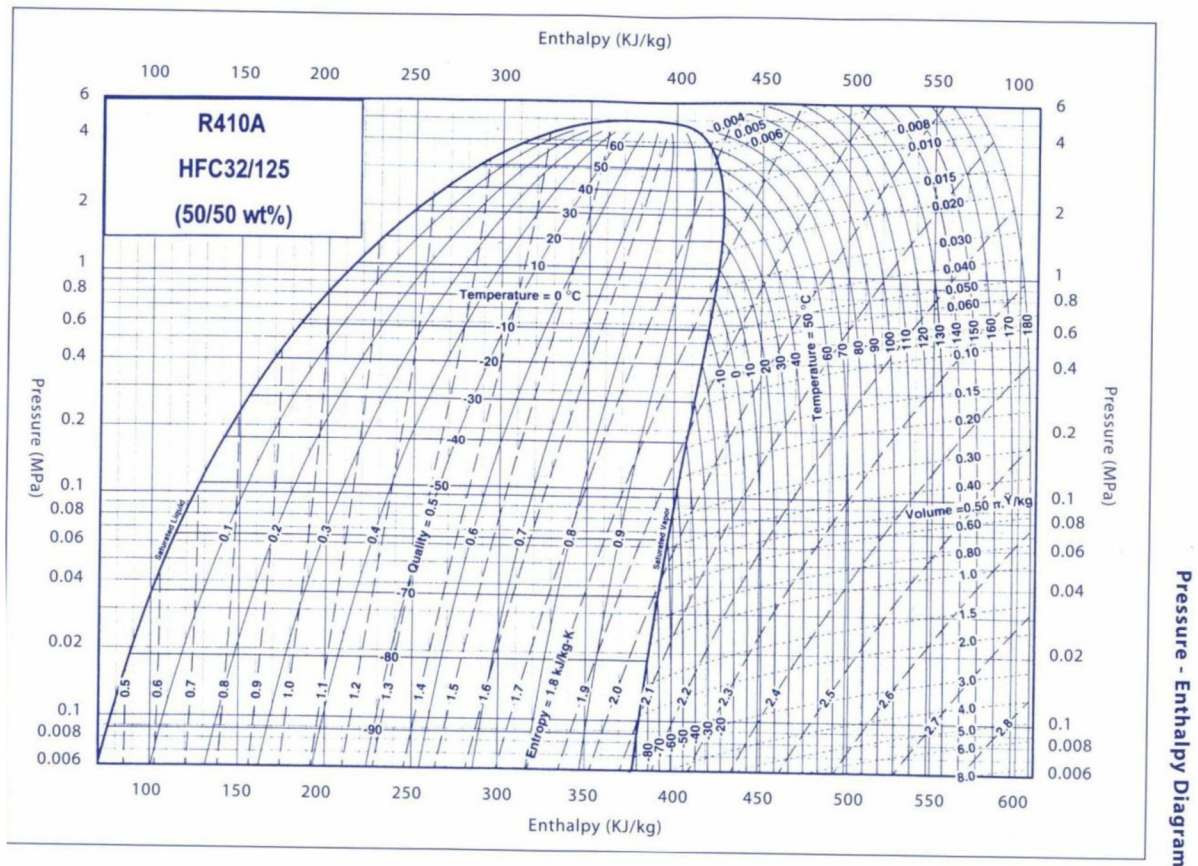

Graph 4.1: p – h diagram of R410A refrigerant

## 4.2.5 Another parts of heat pump

### 4.2.5.1 Receiver

Receiver of refrigerant is specified like a pressure vessel with a round shape and the outlet pipe has to reach the bottom of the container. It serves like reservoir of the whole amount of liquid refrigerant in the heat pump. The receiver is mounted in front of the expansion valve and it's also separating the bubbles. So in front of the expansion valve is refrigerant still fully liquid. At the outlet from the receiver is often connected three way valve with service outlet. The receiver is necessary to use when the amount of the circulated refrigerant has markedly changed. One reason for this is reversible machines. That means machines that are used for heating and also for cooling. It is also installed in the whole air source machines, because of the wide range of evaporation temperatures. The receiver is also necessary to use in the circuits which includes a compressor with modulated speed. There are two types of receivers depending of its axe. It is mainly vertical position, but it can be also placed in horizontal. Receivers have to be designed to the highest pressure that can be in circuit. [6]

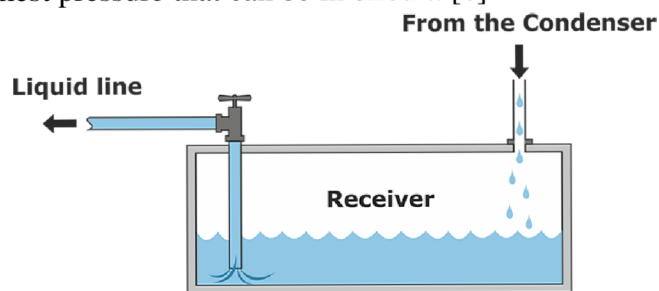

Picture 4.9: Receiver function in the refrigerant circuit



---

#### 4.2.5.2 Separator

If air source heat pumps run in the reverse mode because of defrost, when the output of the compressor is changed by four way valve, it can happen, that liquid refrigerant can come to the suction pipe of the compressor. Because of this problem with the suction pipe in front of the compressor is installed separator of liquid refrigerant. Its function is opposite than receiver's function. Wet steams of refrigerant come to the separator and liquid drops are caught at the bottom and gas part continues to the compressor. Construction of the separator isn't increasing pressure drop in the suction pipe. [3]

#### 4.2.5.3 Filter – dehydrator

It is used to absorb harmful pollutants in the refrigerant circuit such as water and small solid particles. The flow is marked on the shell of the filter by the arrow. It is mounted in vertical position to assure the constant and symmetrical flow of refrigerant with the inlet on the top. For the reversible heat pumps it is necessary to use filter – dehydrator bilateral flow. [6]

#### 4.2.5.4 Four way valve

Four way valve is a special electromagnetic item designed for changing function of the heat pump. It is also used in the air conditioning units for changing from the cooling mode to the heating mode. In the air source heat pumps this valve is used for switching from the heating mode to defrost mode. Valve changes outlet pipe of the compressor for the suction pipe and the suction pipe to the outlet. It is kind of servo – valve, which uses for the motion of the shutters also pressure difference in the pipes. Dimension of the four way valve should fit with pipe dimensions. [3]

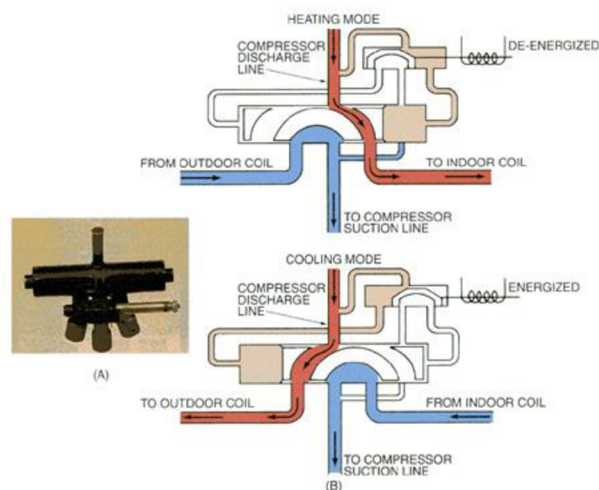

Picture 4.10: Four way valve function

#### 4.2.5.5 Oils

Oils are necessary for the lubrication of the whole compressor during running. Part of the oil, approximately 1/3 also circulates in the whole refrigerant circuit with the refrigerant. It still returns to the compressor and inside of the compressor has to be still sufficient amount of oil. Each refrigerant needs a specific type of lubrication liquid, because oil has to be fully dissoluble in refrigerant. In the past were frequently used mineral oils (M) or some types of refrigerants which need alkyl – benzene oils. Some alternative refrigerants need polyolester oils (POE). [3]



---

#### 4.2.5.6 Pipes

In the cooling technology are primarily used copper pipes, also because of low roughness that cause friction resistance. Those pipes are produced with higher quality than normal pipes for heat distributing circuit with focus on quality of used copper. Pipes are produced with specific dimensions and they are able to stand high pressures. Pipes are produced in two different ways. Hard pipes are produced like straight 5m long pieces and are used for narrow part in the circuit. Those pipes are able to bend only after heating. Soft pipes are produced in twisted packages of length 25 m or 50 m. Those pipes are able to bend easily and are used for complicated connection, for example in split air source units. [3]

#### 4.2.5.7 Sight glass

At least one sight glass is in every circuit. It is used for control of refrigerant flow. Sight glasses also have implemented indicator of humidity. Humidity is indicated by changing the color of middle ring inside glass, for example from green to yellow. The indication is reversible, so it is not necessary to change sight glass after changing the refrigerant. It is normally connected behind the receiver and filter – dehydrator and in front of the expansion valve. In this place are not allowed any bubbles in the refrigerant. If the bubbles are in front of expansion valve that means there is not enough refrigerant in the circuit or some damaged part is causing the high pressure drop. The dimension of the sight glass depends on the dimension of the used pipes. Glass itself is often screwed in and it is possible to change it. It does not depend on the position of the sight glass how it is mounted. [3]



Picture 4.11: Sight glass with humidity indicator

#### 4.2.5.8 Sensors

For the control and regulation of refrigerant circuit have to be integrated thermometers and manometers. For the integration in regulations it is necessary to use electric thermometers like KT-Y or PT 1000. Manometers often have also integrated not only scale in bars, but also temperature scale, which is fitted with a temperature of saturated steam in the actual pressure. Manometers are connected by capillaries to the suction pipe in front of the compressor and to the outlet pipe behind the compressor. Also the scales are adapted to the side of the compressor, where it is connected. Those manometers show also minus values to show under pressure.

---

## 4.3 Types of heat pumps

The main division of the heat pumps is based on the energy source. Primary type of source of heat has main influence on the construction of the heat pump. In the heat pump's name is included name of the low potential source. Heat pumps are most often used for water heating circuits in the building, because this heat distributing system in the buildings is the same like the heating distributing system used when using furnaces.

### 4.3.1 Air source heat pumps

These heat pumps are transferring heat from the air to the heating water. Air source can be outside air or waste air from ventilation. Evaporator is connected at the primary side and it is a lamella heat exchanger with a ventilator. Ventilator increases heat transfer from the air.

Air source heat pumps are often made like split systems. In this type of construction are in outside unit evaporator and expansion valve. In inside unit are condenser, compressor and regulation. In different types of constructions is compressor also in the outside unit. These two parts are connected to isolated copper pipes for refrigerant. Split system is filled by the refrigerant after their installation. The disadvantage of a split system is the noise.

The second system is compact construction. Compact systems can be placed inside or outside. When a heat pump is inside, it is necessary to implement to the house construction, inlet and the outlet of the air. When a heat pump is outside, it is necessary to connect well isolated water pipes of heating circuit.

Advantages air source heat pumps are amount of source medium and no need for other facilities.

Disadvantage of air source heat pumps is water condensation on the evaporator. This water comes from air humidity and it causes ice-build on the evaporator. Cleaning of the evaporator is done by reverse mode in the refrigerant circuit. It is also called the defrost mode. Defrosts are decreasing COP of the heat pump. The heating capacity of these heat pumps depends on the temperature of the air. When air temperatures are deep under zero, heating capacity is low. Because of this air source heat pumps don't cover the whole energy losses of the building. They are used with another source of heat. That means a bivalent source of heat. [3], [4]

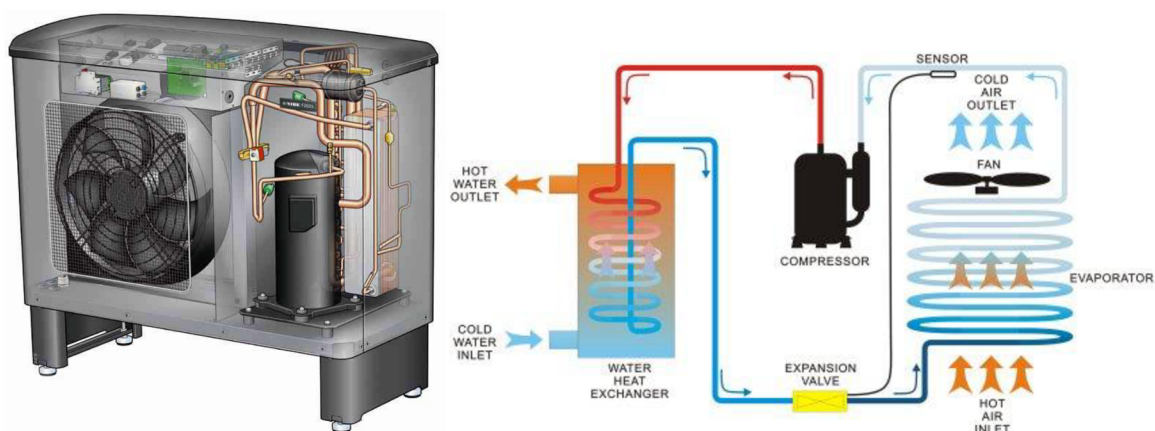

Picture 4.12: Principle and example of outside air source unit

---

### 4.3.2 Water source heat pumps

Water as the source of the latent heat can be the best solution for the heat pumps. Because of higher and stable temperatures of the water (temperatures have to be still above zero) and high specific heat capacity can be reached high and constant values of COPs.

Water source heat pumps can be used like monovalent and can cover the whole demands of heat. The best source of water is two wells. One well is used like a source and second is used for the return of the water. These two wells have to be at least 8 – 10 m away from each other. Water temperature can be stable around 10 °C.

Water flow through evaporator can be regulated by the pump according to demanded heating capacity. This way is also regulated temperature difference, which should be from 3 K to 5K. Regulation of the water circulation pumps is important, because if the water flow isn't high enough, water can freeze in the evaporator. That can damage evaporator and destroy the whole machine. It is also necessary to check the water quality. In the water can't be dissolved lots of minerals and water has to be clean enough. Also, wells have to be able to provide enough water. The cost of the well can be high because it is necessary to drill from 10 to 30 m and the results of the water quality and the quantity don't have to be satisfying. Also rivers or lakes can be used like sources of the water, but the results are not so good like with wells. [3], [4]

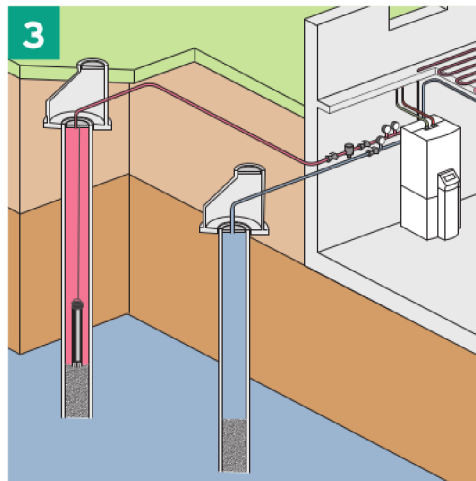

Picture 4.13: Principle of water source heat pump with two wells

### 4.3.3 Brine source Heat pumps

Brine is anti-freezer mixture used like a heat transfer medium at the primary side of the heating circuit. Brine is circulating in various types of heat exchangers. These heat exchangers are collecting the heat most often from the ground. Sometimes are brine source heat pumps called also geothermal heat pumps. There are different ways how to install ground heat collectors.

First is area collector. It is long PE pipe dug in approximately 1,5m underground. Pipe in one collector shouldn't be longer than 200m. Area of collectors should be around 3 or 4 times bigger than is surface of a heated object.

The second are vertical collectors. They are performed like drills from 50 to 120m deep and circa 0,2 m wide. In these drills are inserted two or four pipes, which are at the end connected in special cap at the bottom. According to the required heat output, the

---

number of drills is selected. Drills should be in 5-10m distances. Deeper underground are higher temperatures (10-12°C) and this system doesn't need a large area.

Brine source heat pumps can be installed like monovalent sources of heat also for big applications. Because of heat transfer from the ground to the brine, brine has to be colder than the ground. Brine can reach the temperatures around the 0°C. But also in this case are brine source heat pumps very effectively. Another advantage is that brine like a transfer medium is clean and doesn't cause any troubles in the evaporator.

Disadvantage of the brine source heat pumps is the price of the collectors. All advantages of these heat pumps can be outweighed by the price of the area collectors or drills. It is necessary to install expansion vessel to the circuit filled with brine. [3], [4]

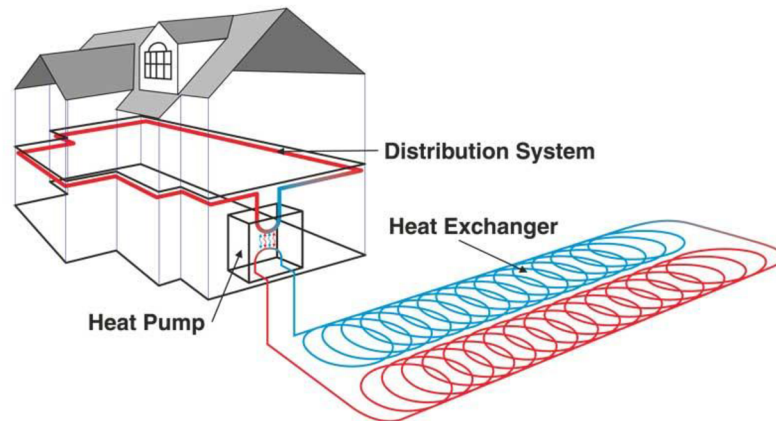

Picture 4.14: Principle of ground source heat pump with area collector

## 5 Tests and calculations

### 5.1 Using sub-cooling for increasing performance of HP

To reach high heat pump efficiencies (Coefficient of Performance - COP) it is necessary to optimize several different parameters of the heat pump cycle. One of these parameters is the sub-cooling of the refrigerant in the condenser below the condensing temperature.

Under several constraints a greater sub-cooling in the condenser means more heating capacity by constant power consumption of the compressor and subsequently higher COPs.

At the time the sub-cooling is controlled by an electronic expansion valve (EEV) after the condenser that regulates the backpressure at the condenser exit (see Graph 5.1). The backpressure leads to an accumulation of the condenser with liquid refrigerant and provided that the heat exchanger area is big enough, the heating capacity will increase without increasing of the condensation temperature. [4]



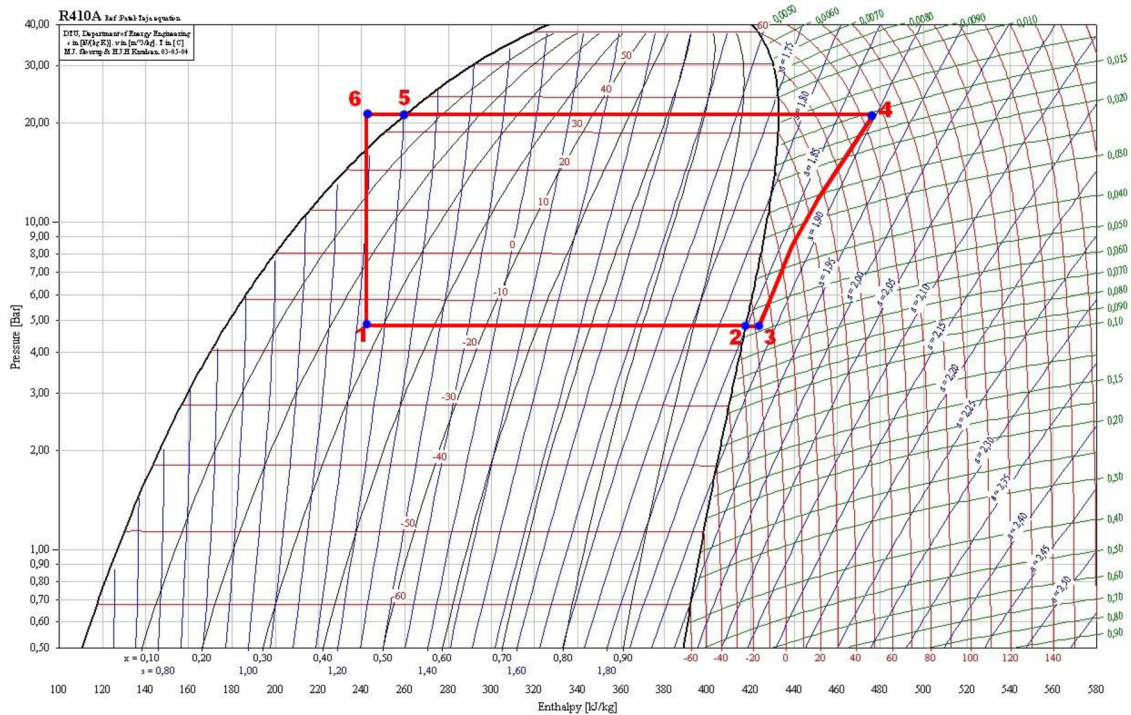

Graph 5.1: Refrigerant circuit drawn in p-h diagram of R410A with sub-cooling showed by the line 5-6

### 5.1.1 Idea of using the capillary

To achieve lower costs for the heat pumps and to reduce control effort it would be advantageous to replace the electronic expansion valve for sub-cooling with a kind of “capillary” that builds up the operating point-dependent backpressure to reach the optimal sub-cooling for each operating point.

## 5.2 Heat pump tests

The heat pump is going to be tested by Rating test for water and brine source HP and also SCOP (Seasonal Coefficient of Performance) test according to European norms. The norms specify conditions of the test such as source temperatures, water temperatures and temperature differences on the heat exchangers. Results give us a possibility to compare different heat pumps in same points and conditions. Main result from the tests is COP.

### 5.2.1 Tested Heat Pump

Tested HP is a compact machine with modulated compressor. Thanks to modulated compressor HP has wide range of heating capacities. This means that when heating demand is lower than is the nominal output of the HP compressor decrease its speed and this decrease also power output. When heating demands are higher, compressor’s speed is increased. The heat pump is designed to the modulated output from 4 – 11 kW of heating power.

---

Electronic expansion valve regulates pressure drop and holds evaporation temperatures and the ideal value. Less start ups of the compressor prolong its lifetime. HP can use like source brine and also water. Plate heat exchangers are used like evaporator and condenser. Even though it is brine source machine, because of the modulated compressor, it is necessary to use the receiver of refrigerant. As the compressor is changing its speed, the mass flow of the refrigerant is changing and the amount of the refrigerant which is circulating is also changing. Receiver ensures enough liquid refrigerant in front of the expansion valve. This heat pump has inserted another electrical expansion valve at the outlet of the condenser. Pressure drop created by second expansion valve holds liquid refrigerant in the condenser and increasing heat taken from the refrigerant by heating water. The results of this effect are going to be compared further in this thesis.

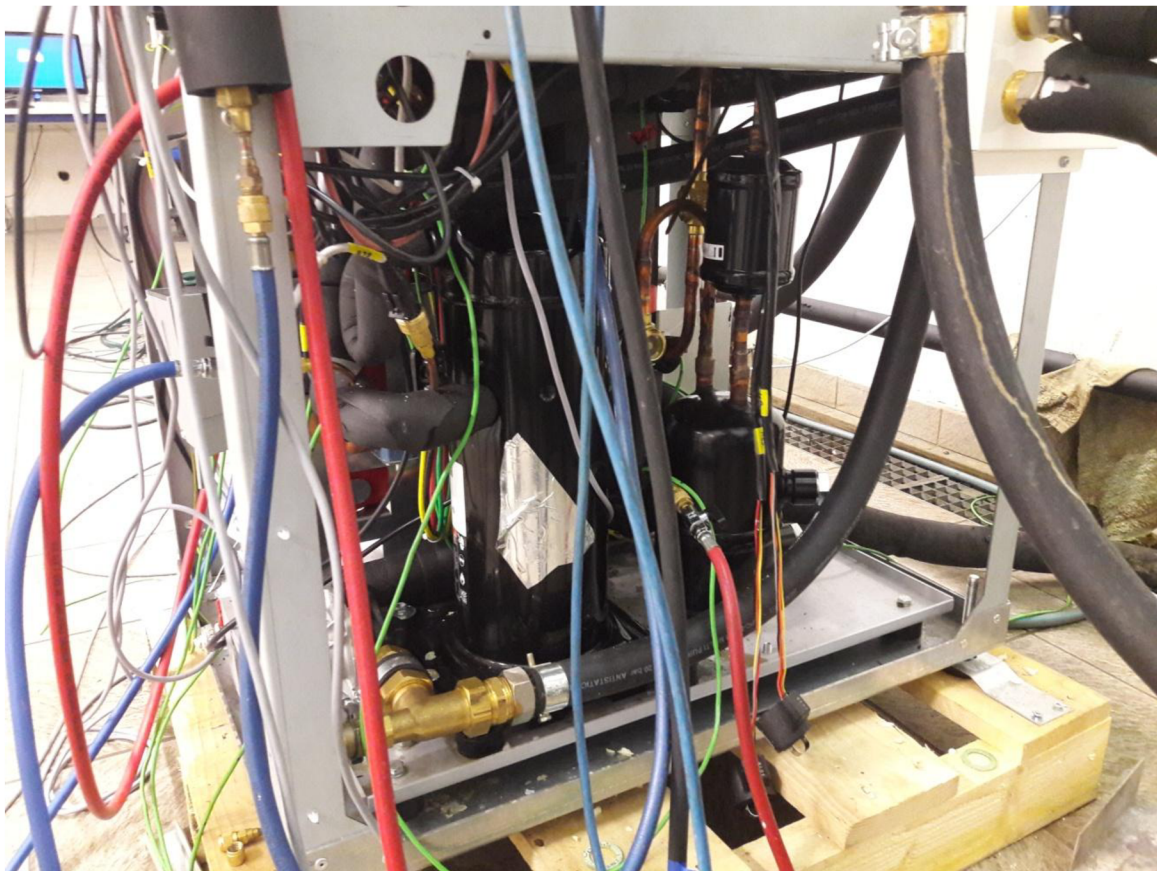

Picture 5.1: Tested heat pump connected to test bench

### 5.2.2 Test bench

HP is connected to the test bench build for rating tests and the functional test. It has two 2000 l buffers. One is for the cooling side or source side of the primary circuit. The second is for the heating side or the secondary circuit. Test bench has its own circulation pumps. Temperature spreads in the evaporator and in condenser are regulated by the pumps. On the primary side and also on the secondary side are installed mixture valves. These mixture valves are regulating temperatures of the source brine and of the heating water.

## Sensors for the calculation of heating capacity

In the following table are types of the sensors used in the test bench for collecting data, heating and cooling capacity calculation and energy consumption.

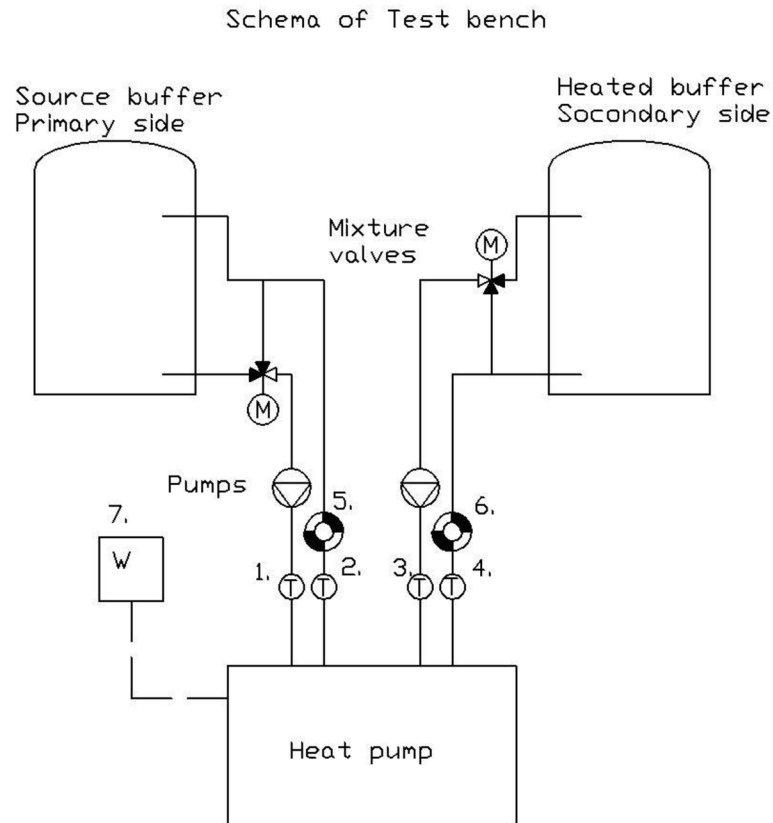

Picture 5.2: Schema of test bench

1.	Source temperature inlet	Pt 100 resistance thermometer
2.	Source temperature outlet	Pt 100 resistance thermometer
3.	Heating water temperature outlet	Pt 100 resistance thermometer
4.	Heating water temperature inlet	Pt 100 resistance thermometer
5.	Mass flow source side	Magnetic inductive mass flow meter
6.	Mass flow heating side	Magnetic inductive mass flow meter
7.	El. Power/Voltage/Current	Power analyzer WM30...96

Table 5.1: Sensors of the test bench



## Sensors used for measuring conditions of the circuit

In the following table are types of the sensors used inside of the heat pump for collecting data from refrigerant circuit in all points and measuring pressure drop through inserted element.

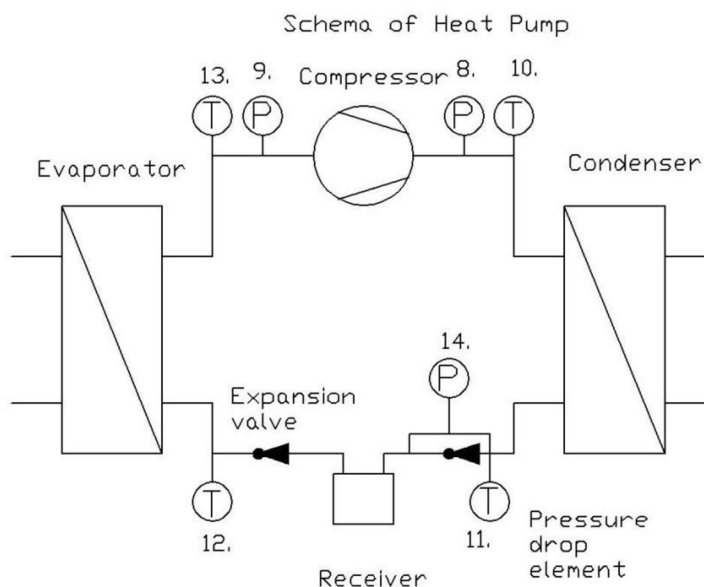

Picture 5.3: Schema of the heat pump and sensors connection

8.	Condensation pressure	Pressure sensor PA-33X / 80794
9.	Evaporation pressure	Pressure sensor PA-33X / 80794
10.	Hot gas temperature	Pt 1000 resistance thermometer
11.	Condensate temperature	Pt 1000 resistance thermometer
12.	Evaporator inlet temperature	Pt 1000 resistance thermometer
13.	Evaporator outlet temperature	Pt 1000 resistance thermometer
14.	Pressure difference of element	connected 2 x Pressure sensor PA-33X / 80794

Table 5.2: Sensors connected in the heat pump

### 5.2.3 Rating test with electronic expansion valve

Rating test is used for testing the heat pumps in specific points. Thanks to the specific points HP can be compared. Rating tests specify temperatures of the source and the heating water on the outlet of the HP. In this case are temperatures of the source, temperatures of the brine on the inlet to the evaporator. Rating test also specify the temperature difference on the heat exchangers. Demanded temperature difference of the brine on the evaporator is 3 K and demanded difference of the water on the condenser is 5 K. These temperature differences have to be fulfilled for the point S0/W35. That means source / brine temperature 0°C, water temperature 35°C. The temperature difference is adjusted by circulation pumps of the test bench.

Measurement has to be 35 minutes long after 25 minutes of stable condition of running HP. From this collected data is created by the Diadem software report. Report contains all necessary information about the behavior of HP during measurement. Sensors



needed for measurement of the HP and data collection for capillary calculation are written above in the section 5.2.2 Test bench.

These data are demanded:

Parameter	Symbol	Units
Heating Capacity	$P_{\text{heating}}$	W
Electricity consumption	$P_{\text{el}}$	W
Condenser entry (water side)	$t_{\text{win}}$	°C
Condenser return (water side)	$t_{\text{wout}}$	°C
Mass flow of the water	$V_{\text{flow}}$	m <sup>3</sup> /h
Absolute condensation pressure	$p_{\text{cond. abs}}$	Bar
Hot gas temperatures	$t_{\text{hotgas}}$	°C
Condensate temperatures	$t_{\text{condensate}}$	°C
Condensation temperature	$t_{\text{cond}}$	°C
Sub-cooling of refrigerant	$T_{\text{sub-cooling}}$	K
Pressure drop of expansion valve	$\Delta p_{\text{exv}}$	Bar

Table 5.3: Data demanded for measurement

Heating power of the HP is calculated from temperature difference of water on the condenser and from the known flow rate according to calorimetric equation. Example calculations are going to be performed for point S0/W35:

$$t_{\text{win}} = 35,06 \text{ } ^\circ\text{C}$$

$$t_{\text{wout}} = 29,97 \text{ } ^\circ\text{C}$$

$$V_{\text{flow}} = 1,123 \text{ m}^3/\text{h}$$

$$\rho_{\text{H}_2\text{O}} = 998 \text{ kg/m}^3$$

$$c_{\text{H}_2\text{O}} = 4180 \text{ J/(kg}\cdot\text{K)}$$

$$P_{\text{heating}} = c_{\text{H}_2\text{O}} \times m_{\text{flow}} \times \Delta t = c_{\text{H}_2\text{O}} \times (V_{\text{flow}} \times \rho_{\text{H}_2\text{O}} / 3600) \times (t_{\text{win}} - t_{\text{wout}}) = \\ = 4180 \times (1,123 \times 998 / 3600) \times (35,06 - 29,97) = \underline{\underline{6623 \text{ W}}}$$

In the following table are source temperatures and heating water temperatures and results corresponding to measured points. Points are set by the norm, but also widened by the company for better data collection. Widened norm is the norm of the company and this norm is subjected to secrecy.

$t_s$	$t_w$	Measur. point	Evap. dT/flow	Cond. dT/flow	$P_{\text{heating}}$	$P_{\text{el}}$	COP
[°C]	[°C]		[K]/[m <sup>3</sup> /h]	[K]/[m <sup>3</sup> /h]	[W]	[W]	
-5	35	S-5/W35	3K / 1,7m <sup>3</sup> /h	5K / 1.14m <sup>3</sup> /h	5767	1475	<b>3,91</b>
0		S0/W35	3K / 1,7m <sup>3</sup> /h	5K / 1.14m <sup>3</sup> /h	6621	1479	<b>4,48</b>
2		S2/W35	3K / 1,7m <sup>3</sup> /h	5K / 1.14m <sup>3</sup> /h	7002	1479	<b>4,73</b>
5		S5/W35	3K / 1,7m <sup>3</sup> /h	5K / 1.14m <sup>3</sup> /h	7621	1472	<b>5,18</b>
10		S10/W35	3K / 1,7m <sup>3</sup> /h	5K / 1.14m <sup>3</sup> /h	8665	1515	<b>5,72</b>
-5	45	S-5/W45	3K / 1,5m <sup>3</sup> /h	5K / 1.1m <sup>3</sup> /h	5415	1775	<b>3,05</b>
0		S0/W45	3K / 1,5m <sup>3</sup> /h	5K / 1.1m <sup>3</sup> /h	6231	1798	<b>3,47</b>
2		S2/W45	3K / 1,5m <sup>3</sup> /h	5K / 1.1m <sup>3</sup> /h	6585	1807	<b>3,64</b>
5		S5/W45	3K / 1,5m <sup>3</sup> /h	5K / 1.1m <sup>3</sup> /h	7171	1815	<b>3,95</b>
10		S10/W45	3K / 1,5m <sup>3</sup> /h	5K / 1.1m <sup>3</sup> /h	8196	1820	<b>4,50</b>
-5	55	S-5/W55	3K / 1,25m <sup>3</sup> /h	5K / 0.98m <sup>3</sup> /h	4955	2112	<b>2,35</b>
0		S0/W55	3K / 1,25m <sup>3</sup> /h	5K / 0.98m <sup>3</sup> /h	5688	2146	<b>2,65</b>
2		S2/W55	3K / 1,25m <sup>3</sup> /h	5K / 0.98m <sup>3</sup> /h	6012	2161	<b>2,78</b>
5		S5/W55	3K / 1,25m <sup>3</sup> /h	5K / 0.98m <sup>3</sup> /h	6582	2186	<b>3,01</b>
10		S10/W55	3K / 1,25m <sup>3</sup> /h	5K / 0.98m <sup>3</sup> /h	7339	2209	<b>3,32</b>
-5	62	S-5/W62	3K / 1,1m <sup>3</sup> /h	5K / 0.93m <sup>3</sup> /h	4749	2406	<b>1,97</b>
0		S0/W62	3K / 1,1m <sup>3</sup> /h	5K / 0.93m <sup>3</sup> /h	5366	2441	<b>2,20</b>
2		S2/W62	3K / 1,1m <sup>3</sup> /h	5K / 0.93m <sup>3</sup> /h	5775	2463	<b>2,34</b>
5		S5/W62	3K / 1,1m <sup>3</sup> /h	5K / 0.93m <sup>3</sup> /h	6275	2487	<b>2,52</b>
10		S10/W62	3K / 1,1m <sup>3</sup> /h	5K / 0.93m <sup>3</sup> /h	7062	2512	<b>2,81</b>

Table 5.4: Rating test of the heat pump with electronic expansion valve

For better illustration follows the graphs with the results:

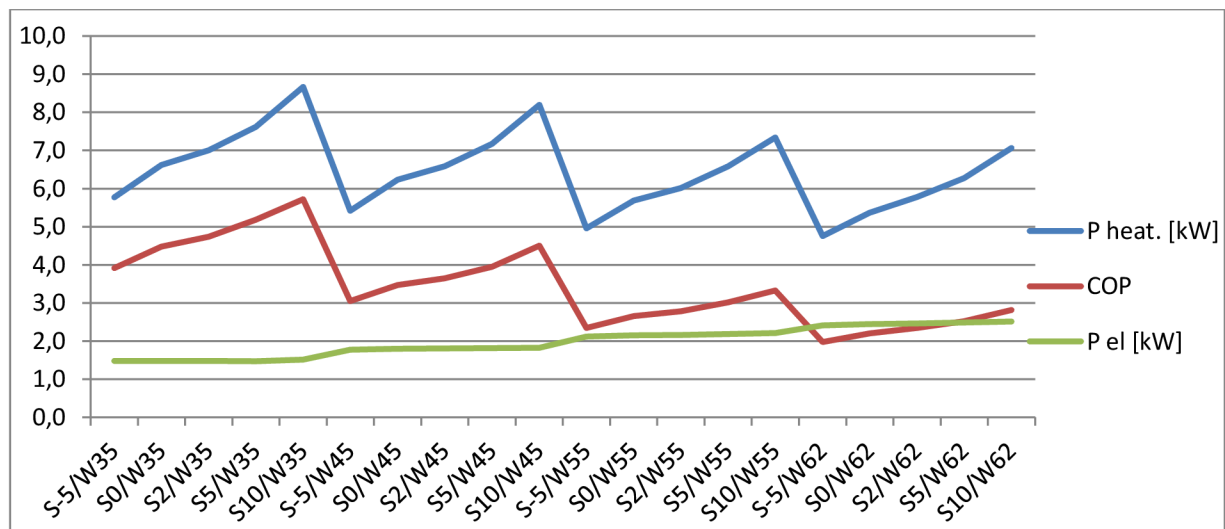

Graph 5.2: Rating test of the heat pump with electronic expansion valve

It is clear from the graph that with increasing source temperature is increasing also COP. Contrarily with increasing water temperature COP is decreasing.

## 5.3 Calculation of capillary

### 5.3.1 Demanded data for calculation

After measurement of points of rating test, data for the next calculation were collected. Data were collected by the sensors of the test bench. These values are necessary for the capillary calculation. From the temperatures of the **Hot gas**, **Condensate** and heating capacity  $P_{\text{heating}}$  is going to be calculated mass flow rate of refrigerant.

Measur. point	$p_{\text{cond. abs}}$ [Bar]	$t_{\text{hotgas}}$ [°C]	$t_{\text{cond}}$ [°C]	$t_{\text{condensate}}$ [°C]	$T_{\text{sub-cooling}}$ [K]	$\Delta p_{\text{exv}}$ [Bar]
S-5/W35	21,1	63,84	34,37	30,94	3,43	1,95
S0/W35	21,2	61,07	34,60	30,56	4,04	2,25
S2/W35	21,2	60,14	34,70	30,44	4,26	2,38
S5/W35	21,3	58,58	34,85	30,20	4,65	2,56
S10/W35	22,2	58,24	36,54	31,15	5,39	3,00
S-5/W45	26,7	78,65	44,17	40,72	3,45	2,38
S0/W45	26,8	75,77	44,31	40,20	4,11	2,72
S2/W45	26,9	74,56	44,38	40,08	4,30	2,84
S5/W45	26,9	72,63	44,50	39,80	4,70	3,08
S10/W45	27,1	69,85	44,71	39,34	5,37	3,50
S-5/W55	33,4	96,24	53,77	49,64	4,13	3,20
S0/W55	33,4	91,93	53,84	49,14	4,70	3,54
S2/W55	33,5	90,64	53,89	48,93	4,96	3,75
S5/W55	33,5	87,92	53,97	48,63	5,34	4,00
S10/W55	33,6	83,86	54,03	48,52	5,51	4,10
S-5/W62	38,6	112,25	60,34	56,03	4,31	3,70
S0/W62	38,7	104,65	60,42	55,49	4,93	4,20
S2/W62	38,7	103,34	60,44	55,25	5,19	4,40
S5/W62	38,8	99,77	60,50	54,92	5,58	4,70
S10/W62	38,7	94,87	60,45	54,80	5,65	4,80

Table 5.4: Demanded data for capillary calculation

#### Demanded pressure drop

$\Delta p_{\text{exv}}$  is measured pressure drop created by the second expansion valve. This pressure drop was needed for reaching the sub-cooling inscribed in the second column from right. Values of the measured pressure drop show us, what should be reached with the capillary. Also those values shouldn't be exceeded because circuit would be unstable and will become less efficient. Pressure drop is going to be different in every point because condensation and evaporation temperatures are changing mass flow of the refrigerant in the circuit.

#### Sub-cooling regulation

$T_{\text{sub-cooling}}$  is measured value. But sub-cooling is regulated by expansion valve. Sub-cooling has to be lower than is temperature difference of the heating water in the condenser. If sub-cooling would be higher it would highly increase condensation temperature  $t_{\text{cond}}$  and also condensation pressure  $p_{\text{cond. abs}}$ . That would cause higher demands to the work of the compressor and also power consumption of the compressor  $P_{\text{el}}$ . That is the reason why is sub-cooling controlled according to this formula:

$$T_{\text{sub-cooling}} = (t_{\text{wout}} - t_{\text{win}}) - 1\text{K}$$

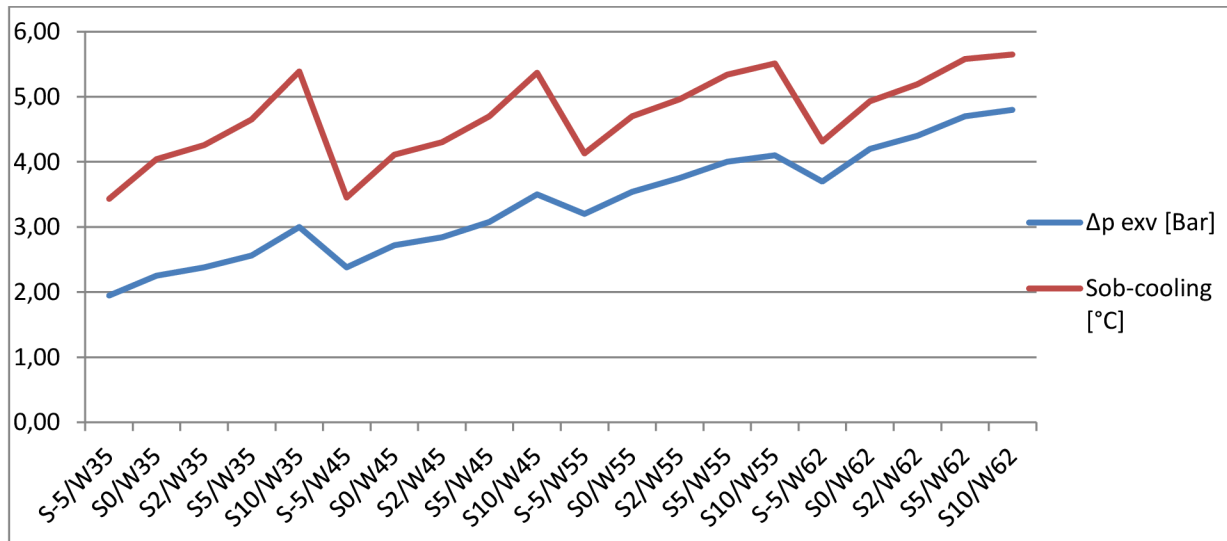

Graph 5.3: Pressure drop of expansion valve and sub-cooling during the rating test

### 5.3.1.1 Calculation of enthalpies, mass flows, densities and viscosities of refrigerant

From the temperatures of hot gas of refrigerant and temperatures of the condensed sub-cooled refrigerant were calculated state variables of the refrigerant in the points of the rating test.

Enthalpies, dynamic viscosity, density were calculated by Engineering Equation Solver (EES) software. Results of the enthalpies from the EES were controlled by COOLPACK software.

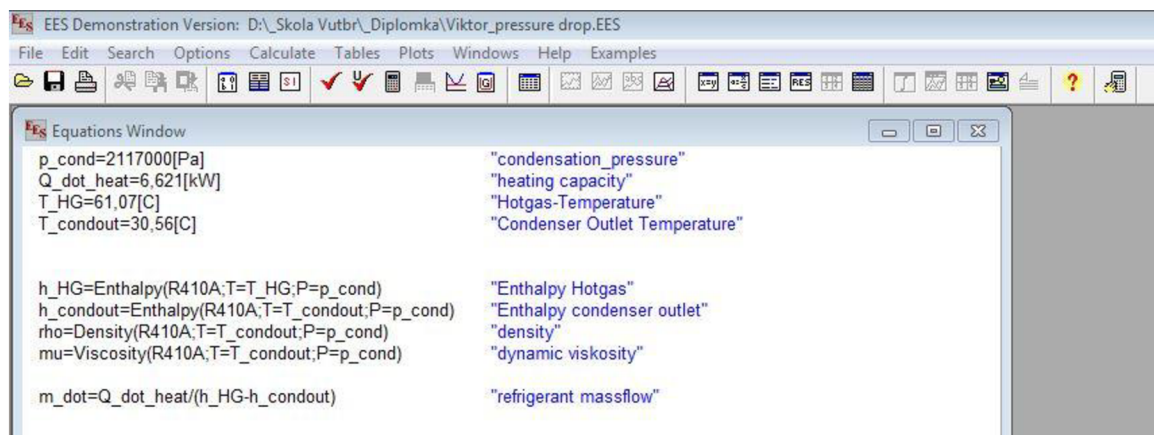

Picture 5.4: Input values into EES for state variables calculation

**Unit Settings: SI C Pa kJ mass deg**

$h_{\text{condout}} = 249,2$ [kJ/kg]	$h_{\text{HG}} = 462,1$ [kJ/kg]	$\mu = 0,0001145$ [kg/m-s]	$\dot{m} = 0,03109$ [kg/s]
$\nu = 1,109\text{E-}07$ [m <sup>2</sup> /s]	$P_{\text{cond}} = 2,117\text{E}+06$ [Pa]	$\dot{Q}_{\text{heat}} = 6,621$ [kW]	$\rho = 1032$ [kg/m <sup>3</sup> ]
$T_{\text{condout}} = 30,56$ [C]	$T_{\text{HG}} = 61,07$ [C]		

No unit problems were detected.

Calculation time = ,0 sec.

Picture 5.5: Calculated values from EES

From the heating capacity of the heat pumps and the known enthalpies of the refrigerant at the inlet and outlet from the condenser, it is possible to calculate mass flow of the refrigerant. Also kinematic viscosity is able to calculate from density and dynamic viscosity. Kinematic viscosity  $\nu$  and mass flows  $m_{\text{flow}}$  were calculated by Excel.

Example calculations are going to be performed for point S0/W35:

Calculation of  $m_{\text{flow}}$  :

$$\begin{aligned}
 P_{\text{heating}} &= 6621 \text{ W} \\
 t_{\text{hot gas}} &= 61,07 \text{ }^\circ\text{C} \\
 t_{\text{condensate}} &= 30,56 \text{ }^\circ\text{C} \\
 p_{\text{condensation}} &= 2117000 \text{ Pa}
 \end{aligned}$$

According to this data EES calculates enthalpies of the inlet and outlet refrigerant:

$$\begin{aligned}
 h_{\text{hot gas}} &= 462,1 \text{ kJ/kg} \\
 h_{\text{condensate}} &= 249,2 \text{ kJ/kg}
 \end{aligned}$$

From know enthalpies and know heating output is possible to calculate mass flow of the refrigerant:

$$\begin{aligned}
 P_{\text{heating}} &= m_{\text{flow}} \times (h_{\text{hot gas}} - h_{\text{condensate}}) \\
 m_{\text{flow}} &= P_{\text{heating}} / (h_{\text{hot gas}} - h_{\text{condensate}}) \\
 m_{\text{flow}} &= 6621 / (462,1 - 249,2) \\
 m_{\text{flow}} &= \underline{\underline{0,0311 \text{ kg/s}}}
 \end{aligned}$$

Calculation of  $\nu$ :

$$\begin{aligned}
 \mu &= 0,00011450 \text{ kg/(m*s)} \\
 \rho &= 1032,00 \text{ kg/m}^3 \\
 \nu &= \mu / \rho \\
 \nu &= 0,00011450 / 1032 \\
 \nu &= \underline{\underline{1,109\text{E-}07 \text{ m}^2/\text{s}}}
 \end{aligned}$$

point	P <sub>heating</sub> [W]	h <sub>hot gas</sub> [kJ/kg]	h <sub>condensate</sub> [kJ/kg]	m <sub>flow</sub> [kg/s]	ρ [kg/m <sup>3</sup> ]	μ [kg/(m*s)]	v [m <sup>2</sup> /s]
S-5/W35	5767,00	465,6	249,90	0,02674	1030,00	0,00011380	1,105E-07
S0/W35	6621,00	462,1	249,20	0,03110	1032,00	0,00011450	1,109E-07
S2/W35	7002,00	460,9	249,00	0,03304	1033,00	0,00011470	1,110E-07
S5/W35	7621,00	458,9	248,60	0,03624	1035,00	0,00011510	1,112E-07
S10/W35	8665,00	456,8	250,20	0,04194	1030,00	0,00011390	1,105E-07
S-5/W45	5415,00	474,6	267,40	0,02613	974,90	0,00010030	1,029E-07
S0/W45	6231,00	470,9	266,40	0,03047	978,70	0,00010120	1,034E-07
S2/W45	6585,00	469,3	266,10	0,03241	979,60	0,00010140	1,035E-07
S5/W45	7171,00	466,8	265,60	0,03564	981,70	0,00010180	1,037E-07
S10/W45	8196,00	463	264,70	0,04133	985,10	0,00010260	1,042E-07
S-5/W55	4955,00	487,3	284,40	0,02442	917,80	0,00008871	9,666E-08
S0/W55	5688,00	481,8	283,30	0,02865	922,30	0,00008958	9,712E-08
S2/W55	6012,00	480,1	282,90	0,03049	924,30	0,00008995	9,732E-08
S5/W55	6582,00	476,4	282,20	0,03389	927,00	0,00009047	9,760E-08
S10/W55	7339,00	470,9	282,00	0,03885	928,00	0,00009067	9,770E-08
S-5/W62	4749,00	501,2	297,50	0,02331	870,50	0,00008041	9,238E-08
S0/W62	5366,00	491,4	296,20	0,02749	876,60	0,00008145	9,291E-08
S2/W62	5775,00	489,7	295,60	0,02975	879,20	0,00008189	9,314E-08
S5/W62	6275,00	484,9	294,80	0,03301	882,90	0,00008251	9,346E-08
S10/W62	7062,00	478,3	294,50	0,03842	884,00	0,00008720	9,356E-08

Table 5.5: Values of the state variables calculated in EES

### 5.3.2 Selection of the capillary

From known mass flows of the refrigerant, it was possible to choose right diameter of the tube used for next calculations and construction of the capillary. Following picture shows standard diameters of the produced capillaries. Length of the capillary depends on its diameter. Capillary with smaller diameter could be shorter. But if the bubbles in condensing refrigerant come to capillary, it will increase pressure drop and that would lead to high pressure shut down. If the diameter will be too big, capillary have to be very long.



Outside Diameter inch (mm)	Inside Diameter inch (mm)	Mean Wall Thickness inch (mm)	Weight Lb/ft (Kg/m)
0.072 (1.830)	0.026 (0.660)	0.023 (0.584)	0.01373 (0.0204)
0.072 (1.830)	0.028 (0.711)	0.022 (0.558)	0.01340 (0.0199)
0.081 (2.060)	0.031 (0.787)	0.025 (0.635)	0.01705 (0.0254)
0.081 (2.060)	0.033 (0.838)	0.024 (0.606)	0.01666 (0.0248)
0.087 (2.210)	0.036 (0.914)	0.0255 (0.648)	0.01910 (0.0284)
0.087 (2.210)	0.039 (0.991)	0.024 (0.606)	0.01842 (0.0239)
0.093 (2.360)	0.042 (1.070)	0.0255 (0.648)	0.02096 (0.0312)
0.097 (2.470)	0.046 (1.170)	0.025 (0.648)	0.02221 (0.0331)
0.099 (2.510)	0.049 (1.240)	0.025 (0.635)	0.02253 (0.0335)
0.106 (2.690)	0.054 (1.370)	0.026 (0.660)	0.02533 (0.0377)
0.112 (2.840)	0.059 (1.500)	0.0265 (0.673)	0.02760 (0.0411)
0.125 (3.180)	0.064 (1.630)	0.0305 (0.775)	0.03511 (0.0522)
0.125 (3.180)	0.070 (1.780)	0.0275 (0.698)	0.03266 (0.0486)
0.125 (3.180)	0.075 (1.910)	0.025 (0.635)	0.03054 (0.0454)
0.145 (3.680)	0.080 (2.030)	0.0325 (0.826)	0.04453 (0.0663)
0.145 (3.680)	0.085 (2.160)	0.030 (0.762)	0.04202 (0.0625)
0.145 (3.680)	0.090 (2.290)	0.0275 (0.698)	0.03936 (0.0586)
0.160 (4.060)	0.100 (2.540)	0.030 (0.762)	0.04750 (0.0707)
0.160 (4.060)	0.110 (2.790)	0.025 (0.635)	0.04111 (0.0611)
0.188 (4.780)	0.120 (3.030)	0.034 (0.864)	0.06377 (0.0949)
0.188 (4.780)	0.130 (3.300)	0.029 (0.737)	0.05616 (0.0836)
0.200 (5.080)	0.145 (3.680)	0.0275 (0.698)	0.05779 (0.0860)
0.220 (5.590)	0.160 (4.060)	0.030 (0.762)	0.06943 (0.103)
0.240 (6.100)	0.175 (4.450)	0.0325 (0.826)	0.08107 (0.121)

Picture 5.6: Catalogue of capillary dimensions [7]

Capillary diameter marker in red frame was chosen after consultation with Product Developer of the company. Capillaries are sold in twisted packages of length 25 m or 50 m. So it is possible to cut demanded length needed for reaching the pressure drop.

For the calculation are most important **inner diameter** of the capillary and **roughness** of the inner surface of the capillary.

$$D_{in} = 2,5 \text{ mm}$$

$$k = 0,0015 \text{ mm}$$

From inner diameter and roughness of the surface is possible to calculate the **Relative Roughness**  $\varepsilon$ . The relative roughness is needed for the determination of the **Friction Factor**  $\lambda$ .

$$\varepsilon = \frac{k}{D_{in}} = \frac{0,0015}{2,5} = 0,0006$$

### 5.3.2.1 Calculation of the velocities in the capillary $v$

Pressure drop caused by the capillary is changing according to velocity of refrigerant in the capillary. Because of different mass flows of refrigerant in different

points of rating test it is necessary to calculate velocities in all points of the measurement and check the pressure drops.

Example calculations are going to be performed for point S0/W35:

$$v = \frac{m_{flow} \div \rho}{\frac{D_{in}^2 \times \pi}{4}} = \frac{0,0311 \div 1032}{\frac{0.0025^2 \times \pi}{4}} = 6,139 \text{ m/s}$$

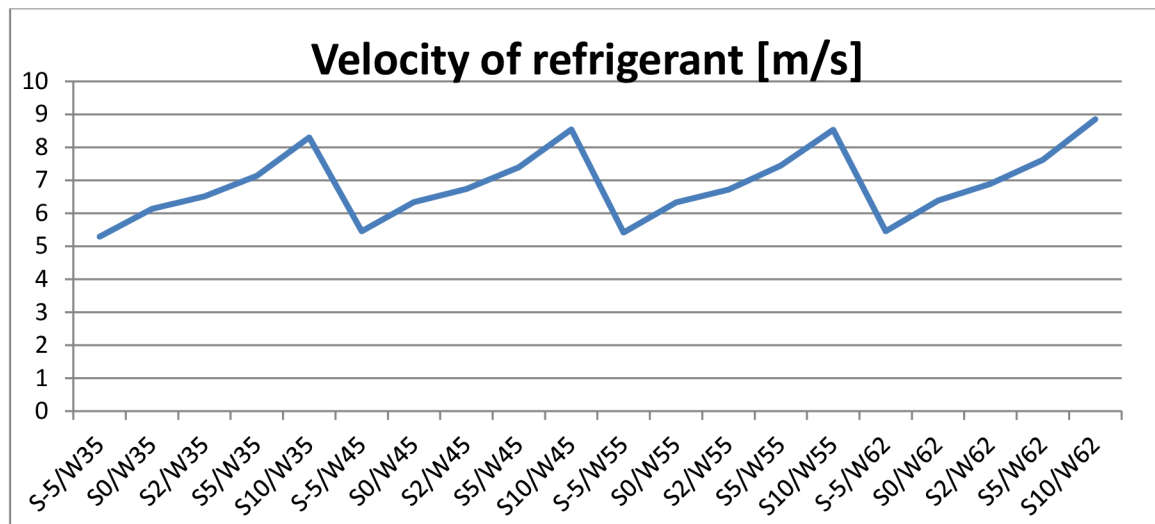

Graph 5.4: Calculated velocities of refrigerant inside of the capillary

Thanks to the higher condensation temperatures is mass flow slightly decreasing but also refrigerant viscosity is decreasing with higher evaporation's temperatures. Result is that velocities of the refrigerant are in similar range.

### 5.3.2.2 Calculation of Reynolds numbers $Re$ and Friction factor $\lambda$

**Reynolds number  $Re$**  is important physical dimensionless value in calculation of friction pressure drop. It shows behavior of the mass flow of the medium. It is condition that specifies laminar or turbulent flow of the medium.

- **Laminar flow** - when  $Re < 2300$
- **Transient flow** - when  $2300 < Re < 4000$
- **Turbulent flow** - when  $Re > 4000$

Example calculations are going to be performed for point S0/W35:

$$Re = \frac{v \times D_{in}}{\vartheta} = \frac{6,139 \times 0,0025}{1,109 \times 10^{-7}} = 138328,78$$

According to Reynolds number flow rate is in all points of rating test highly turbulent. That means, it is possible to expect stabile and linear behavior of pressure drop in the capillary.



**Friction factor  $\lambda$**  is also dimensionless value demanded for the pressure drop calculation. This value is easy to calculate in laminar flow conditions. In turbulent conditions it is more accurate to take this value from Moody chart. *Friction factor* depends on *Reynolds number* and *Relative roughness* of the pipe. Internet offer us various types of Moody chart calculators. In this case was used EES:

```

EES Equations Window
p_cond=2117000[Pa]
RR=0,0006
d_i=0,0025[m]
Q_dot_heat=6,621[kW]
T_HG=61,07[C]
T_condout=30,56[C]

"condensation_pressure"
"pipe roughness"
"inner diameter pipe"
"heating capacity"
"Hotgas-Temperature"
"Condenser Outlet Temperature"

h_HG=Enthalpy(R410A;T=T_HG;P=p_cond)
h_condout=Enthalpy(R410A;T=T_condout;P=p_cond)
rho=Density(R410A;T=T_condout;P=p_cond)
mu=Viscosity(R410A;T=T_condout;P=p_cond)

"Enthalpy Hotgas"
"Enthalpy condenser outlet"
"density"
"dynamic viscosity"

m_dot=Q_dot_heat/(h_HG-h_condout)
v=(m_dot/rho)/(d_i^2*pi/4)

"refrigerant massflow"
"refrigerant speed capillary"

"Re for straight pipes"
Re=v*d_i/nu
nu=mu/rho

"Friction Factor"
lambda=MoodyChart(Re; RR)
  
```

Picture 5.7: Input values into EES for friction factor calculation

```

EES Demonstration Version: D:\Skola Vutbr\Diplomka\Viktor_pressure drop.EES
File Edit Search Options Calculate Tables Plots Windows Help Examples

EES Solution
Main
Unit Settings: SI C Pa kJ mass deg
d_i = 0,0025 [m]
h_condout = 249,2 [kJ/kg]
h_HG = 462,1 [kJ/kg]
lambda = 0,02011
mu = 0,0001145 [kg/m-s]
m_dot = 0,03109 [kg/s]
v = 1,109E-07 [m^2/s]
p_cond = 2,117E+06 [Pa]
Q_dot_heat = 6,621 [kW]
Re = 138357
rho = 1032 [kg/m^3]
RR = 0,0006
T_condout = 30,56 [C]
T_HG = 61,07 [C]
v = 6,135 [m/s]

No unit problems were detected.
Calculation time = ,0 sec.
  
```

Picture 5.8: Friction factor calculation from EES

In the following table are inscribed all values which were calculated above for all points of the rating test.

point	D <sub>in</sub> [m]	ε [-]	v [m/s]	Re	λ <sub>ees</sub>
S-5/W35	0,0025	0,0006	5,288	119654	0,02042
S0/W35	0,0025	0,0006	6,139	138329	0,02011
S2/W35	0,0025	0,0006	6,517	146723	0,01999
S5/W35	0,0025	0,0006	7,133	160349	0,01982
S10/W35	0,0025	0,0006	8,295	187536	0,01955
S-5/W45	0,0025	0,0006	5,461	132702	0,02019
S0/W45	0,0025	0,0006	6,342	153339	0,01990
S2/W45	0,0025	0,0006	6,739	162766	0,01979
S5/W45	0,0025	0,0006	7,396	178309	0,01963
S10/W45	0,0025	0,0006	8,547	205164	0,01940
S-5/W55	0,0025	0,0006	5,421	140204	0,02008
S0/W55	0,0025	0,0006	6,329	162914	0,01979
S2/W55	0,0025	0,0006	6,719	172616	0,01969
S5/W55	0,0025	0,0006	7,448	190798	0,01952
S10/W55	0,0025	0,0006	8,529	218228	0,01931
S-5/W62	0,0025	0,0006	5,456	147663	0,01998
S0/W62	0,0025	0,0006	6,389	171890	0,01970
S2/W62	0,0025	0,0006	6,894	185040	0,01957
S5/W62	0,0025	0,0006	7,616	203749	0,01941
S10/W62	0,0025	0,0006	8,854	224407	0,01919

Table 5.6: Calculated values of Friction factor from EES

### 5.3.3 Capillary's pressure drop calculation

#### 5.3.3.1 Calculation of pressure drop at inlet and outlet of capillary

Before determination of capillary length, it is necessary to calculate inlet and outlet of the capillary. Pressure drop of inlet and outlet are going to be stable values. These values are going to be calculated like local pressure losses in changing diameter. For this calculation it is necessary to know inner diameter of the pipes that are connected to capillary, inner diameter of capillary and the angle of the connection.

Capillary is going to be connected by welding. For connection are going to be used fittings.

Dimensions and drawing of the connections:

$$D_{in} = 0,0025 \text{ m}$$

$$D_{pipe} = 0,0061 \text{ m}$$

$$\alpha_{connection} = 90^\circ$$

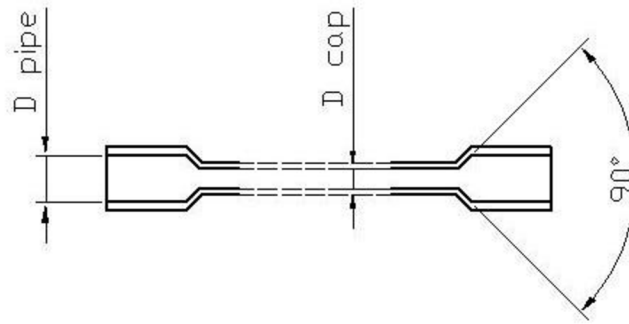

Picture 5.9: Connection of the capillary

Formula for local pressure losses:

$$p_z = K \times C \times \frac{v^2}{2} \times \rho$$

Formula for  $K_{in}$ :

$$K_{in} = 0,5 \times \left(1 - \frac{D_{cap}^2}{D_{pipe}^2}\right)^{0,75}$$

$$K_{in} = 0,5 \times \left(1 - \frac{0.0025^2}{0.0061^2}\right)^{0,75}$$

$$K_{in} = 0.4356$$

[8]

Correction factor of the inlet C:

$$C = \sqrt{\sin \frac{\alpha_{conection}}{2}}$$

$$C = 0.8409$$

[9]

Formula for  $K_{out}$ :

$$K_{out} = \left(1 - \frac{D_{cap}^2}{D_{pipe}^2}\right)^2$$

$$K_{out} = 0.6923$$

[8]

There is no correction factor for the outlet when is  $\alpha_{conection} > 45^\circ$

[9]

**Inlet pressure losses calculated for point S0/W35:**

$$p_{zin} = 0.4356 \times 0.8409 \times \frac{6,139^2}{2} \times 1032 = 7123 [Pa]$$

**Outlet pressure losses calculated for point S0/W35:**

$$p_{zout} = 0.6923 \times \frac{6,139^2}{2} \times 1032 = 13462 [Pa]$$

**Sum of the local pressure losses:**

$$p_{loc} = p_{zout} + p_{zin} = 20584,6 Pa = 0,206 Bar$$

In the following table are values of all local pressure losses in the points of rating test:

point	$p_{zin}$ [Pa]	$p_{zout}$ [Pa]	$p_{loc}$ [Bar]
S-5/W35	5274,86	9969,54	0,15
S0/W35	7123,03	13462,60	0,21
S2/W35	8033,98	15184,30	0,23
S5/W35	9643,92	18227,11	0,28
S10/W35	12980,40	24533,08	0,38
S-5/W45	5324,83	10063,99	0,15
S0/W45	7209,88	13626,74	0,21
S2/W45	8148,24	15400,26	0,24
S5/W45	9834,98	18588,21	0,28
S10/W45	13180,35	24910,99	0,38
S-5/W55	4938,83	9334,43	0,14
S0/W55	6766,66	12789,06	0,20
S2/W55	7642,93	14445,21	0,22
S5/W55	9418,60	17801,24	0,27
S10/W55	12362,62	23365,48	0,36
S-5/W62	4745,72	8969,46	0,14
S0/W62	6552,23	12383,77	0,19
S2/W62	7652,69	14463,65	0,22
S5/W62	9379,95	17728,19	0,27
S10/W62	12692,90	23989,71	0,37

Table 5.7: Pressure losses caused by inlet and outlet

### 5.3.3.2 Calculation of capillary's length

Now it is possible to calculate length of the capillary. In the refrigerant circuit is not circulating pure refrigerant but mixture of refrigerant and compressor oil. Also it's necessary to avoid high pressure drop, because it is possible to get bi-state flow in the capillary which would increase the pressure drop and refrigeration could be unstable. After the consultation with Product Developer was decided to design capillary with **0,5 Bar** less pressure drop. As calculation point for the capillary were chosen point S0/W35.

From the known demanded values of pressure drop, all data for the capillary calculation are now collected.

#### Values needed for the capillary calculation:

Point for the calculation		S0/W35
Pressure drop of expansion valve	$\Delta p_{exv}$	2,25 Bar
Inner diameter of capillary	$D_{cap}$	0,0025 m
Velocity in side of capillary	$v$	6,139 m/s
Density of refrigerant	$\rho$	1032 kg/m <sup>3</sup>
Friction factor	$\lambda$	0,02011
Pressure drop of inlet and outlet	$p_{loc}$	0,206 Bar
Safety condition	$p_{safety}$	0,5 Bar

Table 5.8: Values needed for capillary calculation

---

**Formula for friction pressure drop:**

$$\Delta p = \frac{\lambda}{D} \times \rho \times \frac{v^2}{2} \times l$$

[10]

**Capillary pressure drop demands:**

From the pressure drop created by expansion valve  $p_{exv}$  it is necessary to subtract local pressure losses  $p_{loc}$  and safety condition  $p_{safety}$ :

$$\Delta p = \Delta p_{exv} - p_{loc} - p_{safety}$$

$$\Delta p = 2,25 - 0,206 - 0,5$$

$$\Delta p = 1,544 \text{ Bar} = 154400 \text{ Pa}$$

**Calculation of the length:**

$$l = \frac{\Delta p \times D \times 2}{\lambda \times \rho \times v^2}$$
$$l = \frac{154400 \times 0,0025 \times 2}{0,02011 \times 1032 \times 6,139^2}$$

$$l = 0,99 \text{ m}$$

After calculation of the length for the point S0/W35 can be performed calculations for all points of the rating test with capillary's length 1 m. Value  $\Delta p_{calc}$  is sum of the friction pressure losses  $p_{cap}$  and local pressure losses  $p_{loc}$ . All values have to be compared with pressure drop of expansion valve  $\Delta p_{exv}$ , to avoid too high pressure drop in some measurement point and inflicting the problems with the heat pump run.

In following table are compared all points:

point	$\Delta p_{exv}$	$p_{cap}$	$p_{loc}$	$\Delta p_{calc}$	$(p_{exv} - p_{sum})$
	[Bar]	[Bar]	[Bar]	[Bar]	[Bar]
S-5/W35	1,95	1,17	0,15	1,32	0,63
S0/W35	2,25	1,55	0,21	1,76	0,49
S2/W35	2,38	1,74	0,23	1,98	0,40
S5/W35	2,56	2,07	0,28	2,35	0,21
S10/W35	3,00	2,75	0,38	3,13	-0,13
S-5/W45	2,38	1,17	0,15	1,32	1,06
S0/W45	2,72	1,56	0,21	1,77	0,95
S2/W45	2,84	1,75	0,24	1,99	0,85
S5/W45	3,08	2,09	0,28	2,38	0,70
S10/W45	3,50	2,77	0,38	3,16	0,34
S-5/W55	3,20	1,08	0,14	1,22	1,98
S0/W55	3,54	1,45	0,20	1,65	1,89
S2/W55	3,75	1,63	0,22	1,85	1,90
S5/W55	4,00	1,99	0,27	2,27	1,73
S10/W55	4,10	2,59	0,36	2,95	1,15
S-5/W62	3,70	1,03	0,14	1,17	2,53
S0/W62	4,20	1,40	0,19	1,59	2,61
S2/W62	4,40	1,62	0,22	1,85	2,55
S5/W62	4,70	1,98	0,27	2,25	2,45
S10/W62	4,80	2,65	0,37	3,02	1,78

Table 5.9: Calculated pressure drops of the capillary in whole range of rating test



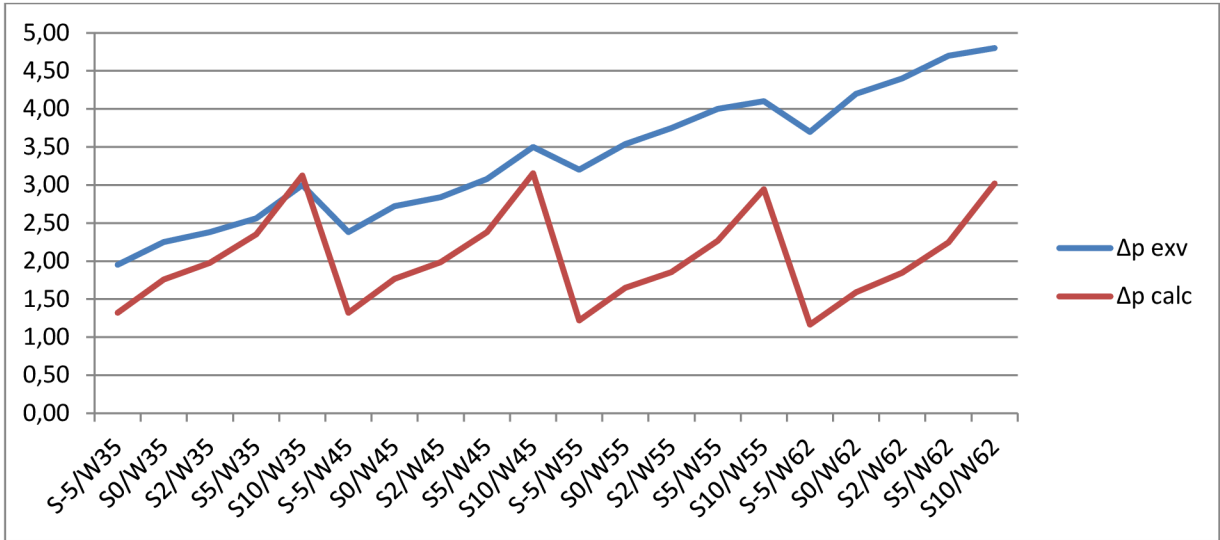

Graph 5.5: Calculated  $\Delta p_{exv}$  of the capillary compared with  $\Delta p_{calc}$  of expansion valve

From the table it is clear that pressure drop values shouldn't be exceeded in any point of rating test. Now it is possible to construct the capillary and install it inside of the tested heat pump instead of electronic expansion valve.



Picture 5.10: Photo of connections of constructed capillary



Picture 5.11: Photo of constructed capillary

## 5.4 Rating test with capillary and with pipe

### 5.4.1 Rating test with capillary

After capillary installation, heat pump was filled with the same amount of refrigerant as the refrigerant circuit with electronic expansion valve. It is necessary to have the same amount of refrigerant to get comparable results. If machine was filled with more refrigerant, it could have been possible to flood capillary with liquid refrigerant and also the condenser. The result would be higher sub-cooling and different results of measurement. If there was not enough refrigerant, it could cause unstable refrigeration and in this case it would be possible to get demanded conditions for the rating test.

The rating test with capillary was performed with the same conditions like the rating test with expansion valve. Main conditions for the rating test are temperature differences on the condenser and on the evaporator which have to be accomplished for the source temperature 0 °C and demanded heating water temperature 35 °C, 45 °C, 55 °C, 62 °C.

$$\Delta T_{cond} = 5 \text{ K}$$

$$\Delta T_{evap} = 3 \text{ K}$$

According to this conditions, have to be changed also the mass flows of brine and heating water. In the following table are measured values of the heating capacities, electric consumptions and COPs. It is also possible to see differences in the flow rates.

$t_s$	$t_w$	Measur. point	Evap. dT/flow	Cond. dT/flow	$P_{heating}$	$P_{el}$	COP
[°C]	[°C]		[K]/[m <sup>3</sup> /h]	[K]/[m <sup>3</sup> /h]	[W]	[W]	
-5	35	S-5/W35	3K / 1,7m <sup>3</sup> /h	5K / 1.14m <sup>3</sup> /h	5595	1467	<b>3,81</b>
0		S0/W35	3K / 1,7m <sup>3</sup> /h	5K / 1.14m <sup>3</sup> /h	6593	1476	<b>4,47</b>
2		S2/W35	3K / 1,7m <sup>3</sup> /h	5K / 1.14m <sup>3</sup> /h	6889	1474	<b>4,67</b>
5		S5/W35	3K / 1,7m <sup>3</sup> /h	5K / 1.14m <sup>3</sup> /h	7551	1470	<b>5,14</b>
10		S10/W35	3K / 1,7m <sup>3</sup> /h	5K / 1.14m <sup>3</sup> /h	8731	1463	<b>5,97</b>
-5	45	S-5/W45	3K / 1,5m <sup>3</sup> /h	5K / 1.05m <sup>3</sup> /h	5220	1768	<b>2,95</b>
0		S0/W45	3K / 1,5m <sup>3</sup> /h	5K / 1.05m <sup>3</sup> /h	6116	1792	<b>3,41</b>
2		S2/W45	3K / 1,5m <sup>3</sup> /h	5K / 1.05m <sup>3</sup> /h	6478	1803	<b>3,59</b>
5		S5/W45	3K / 1,5m <sup>3</sup> /h	5K / 1.05m <sup>3</sup> /h	7046	1810	<b>3,89</b>
10		S10/W45	3K / 1,5m <sup>3</sup> /h	5K / 1.05m <sup>3</sup> /h	8299	1809	<b>4,59</b>
-5	55	S-5/W55	3K / 1.1m <sup>3</sup> /h	5K / 0.93m <sup>3</sup> /h	4757	2088	<b>2,28</b>
0		S0/W55	3K / 1.1m <sup>3</sup> /h	5K / 0.93m <sup>3</sup> /h	5523	2131	<b>2,59</b>
2		S2/W55	3K / 1.1m <sup>3</sup> /h	5K / 0.93m <sup>3</sup> /h	5703	2142	<b>2,66</b>
5		S5/W55	3K / 1.1m <sup>3</sup> /h	5K / 0.93m <sup>3</sup> /h	6291	2171	<b>2,90</b>
10		S10/W55	3K / 1.1m <sup>3</sup> /h	5K / 0.93m <sup>3</sup> /h	7377	2194	<b>3,36</b>
-5	62	S-5/W62	3K / 1.0m <sup>3</sup> /h	5K / 0.88m <sup>3</sup> /h	4551	2392	<b>1,90</b>
0		S0/W62	3K / 1.0m <sup>3</sup> /h	5K / 0.88m <sup>3</sup> /h	5213	2437	<b>2,14</b>
2		S2/W62	3K / 1.0m <sup>3</sup> /h	5K / 0.88m <sup>3</sup> /h	5558	2453	<b>2,27</b>
5		S5/W62	3K / 1.0m <sup>3</sup> /h	5K / 0.88m <sup>3</sup> /h	5915	2461	<b>2,40</b>
10		S10/W62	3K / 1.0m <sup>3</sup> /h	5K / 0.88m <sup>3</sup> /h	6650	2493	<b>2,67</b>

Table 5.10: Rating test of the heat pump with the capillary

For better illustration follow graphs with the results:

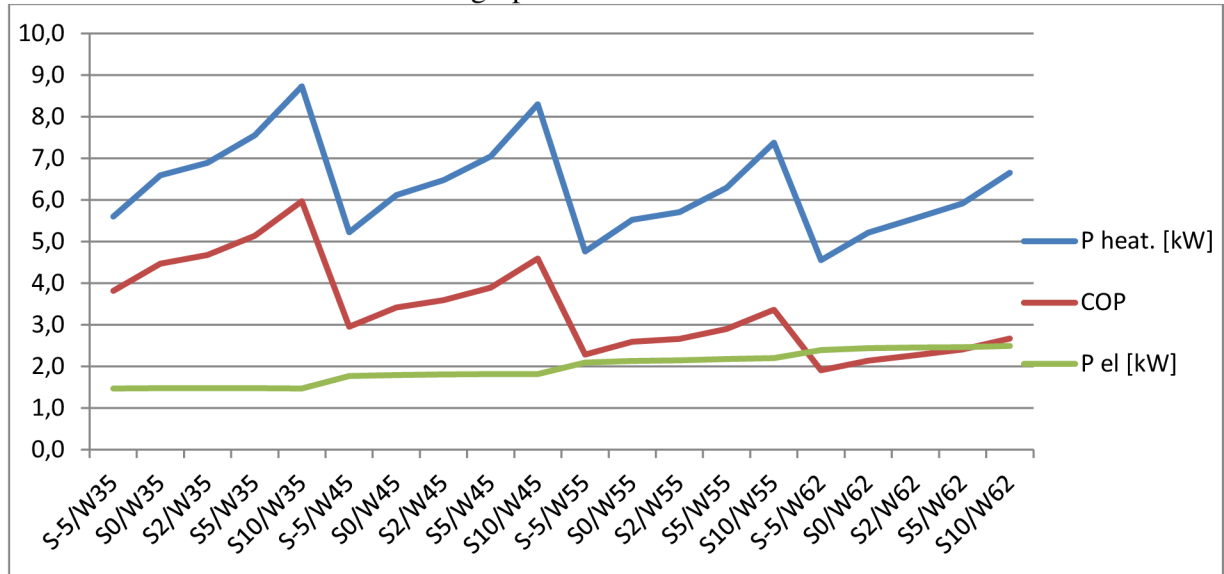

Graph 5.6: Rating test of the heat pump with the capillary

Comparison of the measured values is going to be performed further in this thesis.

#### 5.4.2 Comparison of calculated and measured pressure drop

As in the rating test of the heat pumps with expansion valve, also now were measured all values and reports from measurement were created by Diadem software.

In following table are compared calculated and measured pressure drops and sub-cooling values with expansion valve and capillary:

point	$\Delta p_{calc}$ [Bar]	$\Delta p_{meas.}$ [Bar]	(dp calc - dp meas.) [Bar]
S-5/W35	1,32	1,03	-0,29
S0/W35	1,76	1,54	-0,22
S2/W35	1,98	1,64	-0,34
S5/W35	2,35	2,02	-0,33
S10/W35	3,13	2,77	-0,36
S-5/W45	1,32	1,14	-0,18
S0/W45	1,77	1,52	-0,25
S2/W45	1,99	1,77	-0,22
S5/W45	2,38	2,05	-0,33
S10/W45	3,16	3,05	-0,11
S-5/W55	1,22	0,99	-0,23
S0/W55	1,65	1,57	-0,08
S2/W55	1,85	1,46	-0,39
S5/W55	2,27	1,83	-0,44
S10/W55	2,95	3,13	0,18
S-5/W62	1,17	1,14	-0,03
S0/W62	1,59	1,55	-0,04
S2/W62	1,85	1,77	-0,08
S5/W62	2,25	2,16	-0,09
S10/W62	3,02	2,80	-0,22

Table 5.11: Differences in calculated and measured pressure drop

Differences in calculated and measured values are caused by different sub-cooling. That means also condensation temperatures were different. It is necessary to evaluate that pressure drops were calculated with pure refrigerant. But real circulating mass inside of heating circuit is mixture of refrigerant and compressor oil which is fully dissolved in the refrigerant. This means that calculated values of pressure drop were just orientational.

Here is comparison of condensation temperatures and sub-cooling temperatures:

Point	t cond. Exv	t cond. Cap	dT <sub>cond</sub>	T <sub>sub-cooling exv</sub>	T <sub>sub-cooling cap</sub>	dT <sub>sub</sub>
	[°C]	[°C]	[°C]	[K]	[K]	[K]
S-5/W35	34,37	34,16	0,21	3,43	1,68	1,75
S0/W35	34,60	34,49	0,11	4,04	2,74	1,30
S2/W35	34,70	34,49	0,21	4,26	2,71	1,55
S5/W35	34,85	34,68	0,17	4,65	3,71	0,94
S10/W35	36,54	34,95	1,59	5,39	5,21	0,18
S-5/W45	44,17	44,00	0,17	3,45	1,71	1,74
S0/W45	44,31	44,09	0,22	4,11	2,40	1,71
S2/W45	44,38	44,16	0,22	4,30	2,81	1,49
S5/W45	44,50	44,24	0,26	4,70	3,28	1,42
S10/W45	44,71	44,34	0,37	5,37	4,71	0,66
S-5/W55	53,77	53,48	0,29	4,13	1,44	2,69
S0/W55	53,84	53,51	0,33	4,70	2,01	2,69
S2/W55	53,89	53,52	0,37	4,96	2,12	2,84
S5/W55	53,97	53,56	0,41	5,34	2,63	2,71
S10/W55	54,03	53,59	0,44	5,51	4,19	1,32
S-5/W62	60,34	59,92	0,42	4,31	1,47	2,84
S0/W62	60,42	59,94	0,48	4,93	1,98	2,95
S2/W62	60,44	59,91	0,53	5,19	2,26	2,93
S5/W62	60,50	59,81	0,69	5,58	2,73	2,85
S10/W62	60,45	60,03	0,42	5,65	3,49	2,16

Table 5.12: Comparison of the condensation temperatures and sub-cooling temperatures

Mainly lower **heating capacities**  $P_{\text{heating}}$  decreased **flow rate** of refrigerant in the circuit. Those lower flow rates decrease velocity  $v$  of the refrigerant inside of the capillary. According to lower velocities also **pressure drop** of the capillary is lower. Differences in condensation temperatures and in the amount of sub-cooling could cause different flow rates of refrigerant in the circuit.

### 5.4.3 Rating test with pipe

At the end was for the better comparison of the results and mainly for comparison of sub-cooling effect measured heat pump with no pressure drop element inserted. The heat pump was filled with the same amount of refrigerant and all conditions of the rating test were accomplished.

ts	tw	Measur. point	Evap. dT/flow	Cond. dT/flow	P <sub>heating</sub>	P <sub>el</sub>	COP
[°C]	[°C]		[K]/[m <sup>3</sup> /h]	[K]/[m <sup>3</sup> /h]	[W]	[W]	
-5	35	S-5/W35	3K / 1,7m <sup>3</sup> /h	5K / 1.14m <sup>3</sup> /h	5543	1472	3,77
0		S0/W35	3K / 1,7m <sup>3</sup> /h	5K / 1.14m <sup>3</sup> /h	6401	1474	4,34
2		S2/W35	3K / 1,7m <sup>3</sup> /h	5K / 1.14m <sup>3</sup> /h	6827	1475	4,63
5		S5/W35	3K / 1,7m <sup>3</sup> /h	5K / 1.14m <sup>3</sup> /h	7298	1469	4,97
10		S10/W35	3K / 1,7m <sup>3</sup> /h	5K / 1.14m <sup>3</sup> /h	8365	1455	5,75
-5	45	S-5/W45	3K / 1,4m <sup>3</sup> /h	5K / 1.03m <sup>3</sup> /h	5327	1768	3,01
0		S0/W45	3K / 1,4m <sup>3</sup> /h	5K / 1.03m <sup>3</sup> /h	6026	1792	3,36
2		S2/W45	3K / 1,4m <sup>3</sup> /h	5K / 1.03m <sup>3</sup> /h	6376	1797	3,55
5		S5/W45	3K / 1,4m <sup>3</sup> /h	5K / 1.03m <sup>3</sup> /h	6875	1804	3,81
10		S10/W45	3K / 1,4m <sup>3</sup> /h	5K / 1.03m <sup>3</sup> /h	7786	1807	4,31
-5	55	S-5/W55	3K / 1.1m <sup>3</sup> /h	5K / 0.93m <sup>3</sup> /h	4598	2079	2,21
0		S0/W55	3K / 1.1m <sup>3</sup> /h	5K / 0.93m <sup>3</sup> /h	5290	2121	2,49
2		S2/W55	3K / 1.1m <sup>3</sup> /h	5K / 0.93m <sup>3</sup> /h	5534	2140	2,59
5		S5/W55	3K / 1.1m <sup>3</sup> /h	5K / 0.93m <sup>3</sup> /h	6017	2166	2,78
10		S10/W55	3K / 1.1m <sup>3</sup> /h	5K / 0.93m <sup>3</sup> /h	6790	2187	3,1
-5	62	S-5/W62	3K / 0.95m <sup>3</sup> /h	5K / 0.9m <sup>3</sup> /h	4545	2390	1,9
0		S0/W62	3K / 0.95m <sup>3</sup> /h	5K / 0.9m <sup>3</sup> /h	5119	2405	2,13
2		S2/W62	3K / 0.95m <sup>3</sup> /h	5K / 0.9m <sup>3</sup> /h	5444	2446	2,23
5		S5/W62	3K / 0.95m <sup>3</sup> /h	5K / 0.9m <sup>3</sup> /h	5700	2464	2,31
10		S10/W62	3K / 0.95m <sup>3</sup> /h	5K / 0.9m <sup>3</sup> /h	6376	2487	2,56

Table 5.13: Rating test of the heat pump with the pipe

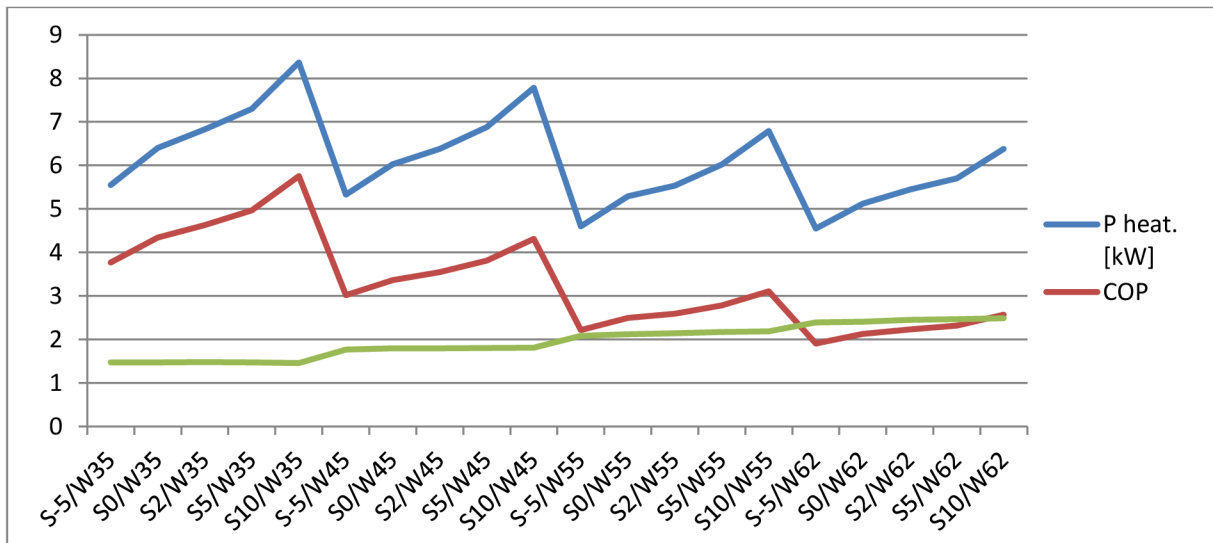

Graph 5.7: Rating test of the heat pump with the pipe



---

## 6 Evaluation of the measured results

### 6.1 Main characteristics comparison of different types of sub-cooling

In the following part are compared the most important values and results of the measurements. On these results will be possible to see sub-cooling's effect to the refrigeration and also are going to be compared two variants of creating a pressure drop needed for sub-cooling: Electronic expansion valve and Capillary.

#### 6.1.1 Heating capacities comparison

The clearest way how to compare different variants of the sub-cooling is a comparison of the power outputs of all three variants. For better illustration are going to be made a comparison in divided graphs for different source temperature. Each temperature of heating water needs the same input of energy for reaching demanded value. Graphs show heating capacities for source temperatures  $-5\text{ }^{\circ}\text{C}$ ,  $0\text{ }^{\circ}\text{C}$ ,  $10\text{ }^{\circ}\text{C}$ .

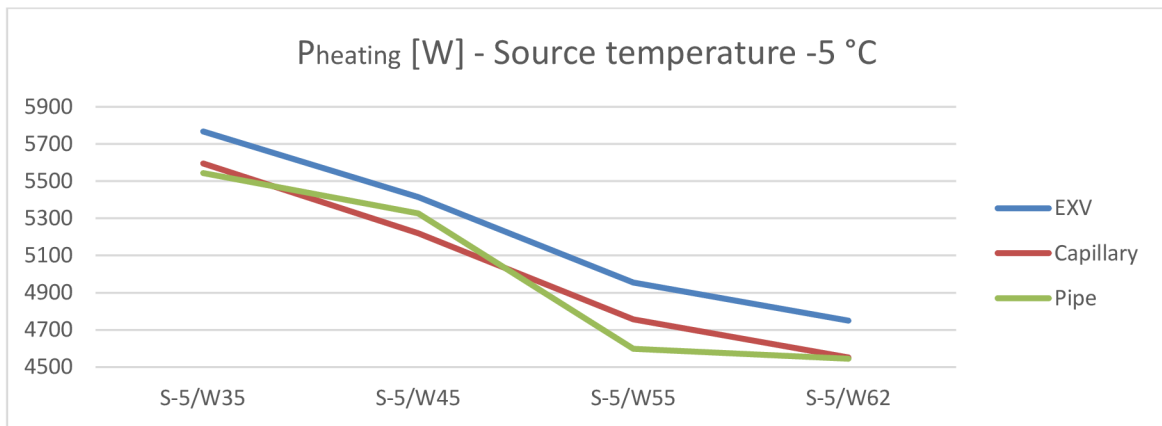

Graph 5.8: Comparison of  $P_{\text{heating}}$  with the source temperature  $-5\text{ }^{\circ}\text{C}$

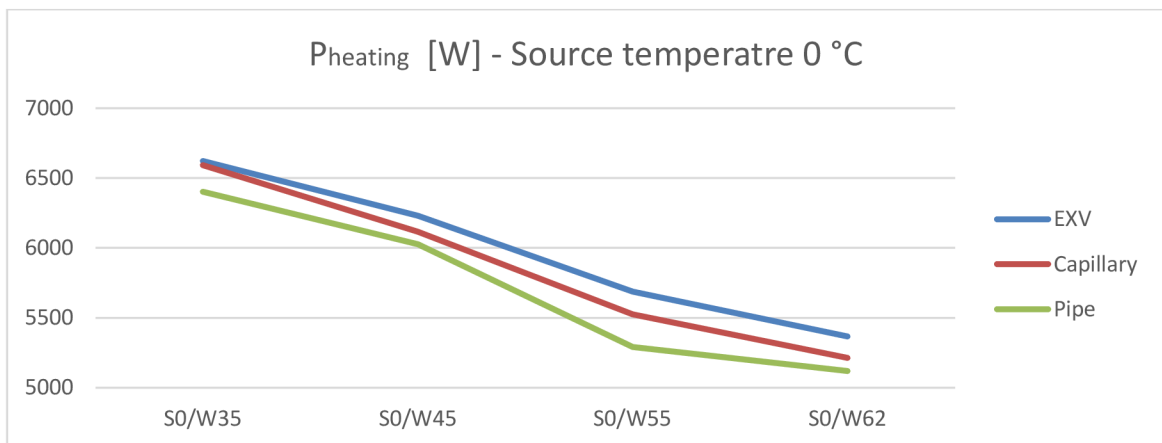

Graph 5.9: Comparison of  $P_{\text{heating}}$  with the source temperature  $0\text{ }^{\circ}\text{C}$

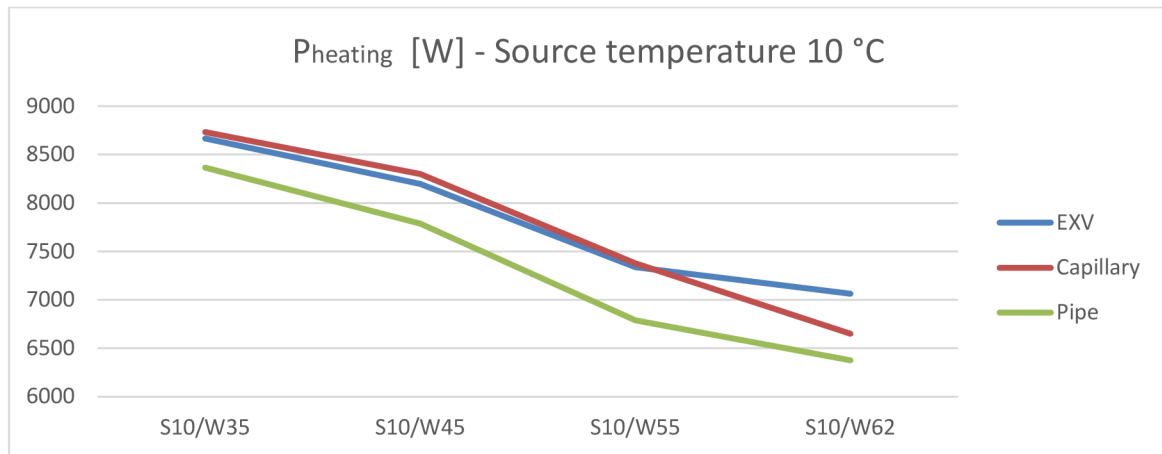

Graph 5.10: Comparison of P<sub>heating</sub> with the source temperature 10 °C

The graphs show the heating gains from sub-cooling. In source temperature -5 °C are the flow rates of the refrigerant the lowest of the whole range. The biggest gains bring the expansion valve, because it adjusts its position and increase the pressure drop. Because of the low mass flow is the pressure drop of the capillary low, also sub-cooling is low and the results are similar as with no pressure drop element.

For the graphs with the source temperature 10 °C it is also possible to see that the regulation of the expansion valve can be improved. At this point it is possible that refrigeration was behind the line of the useful sub-cooling.

Formula for the regulation of sub-cooling could be:

$$T_{\text{sub-cooling}} = (t_{\text{wout}} - t_{\text{win}}) - 2K$$

Pheating EXV [W]	Pheating CAP [W]	Pheating PIPE [W]	Gains EXV [%]	Gains CAP [%]
5767	5595	5543	4,04	0,94
6621	6593	6401	3,44	3,00
7002	6889	6827	2,56	0,91
7621	7551	7298	4,43	3,47
8665	8731	8365	3,59	4,38
5415	5220	5327	1,65	-2,01
6231	6116	6026	3,40	1,49
6585	6478	6376	3,28	1,60
7171	7046	6875	4,31	2,49
8196	8299	7786	5,27	6,59
4955	4757	4598	7,76	3,46
5688	5523	5290	7,52	4,40
6012	5703	5534	8,64	3,05
6582	6291	6017	9,39	4,55
7339	7377	6790	8,09	8,65
4749	4551	4545	4,49	0,13
5366	5213	5119	4,83	1,84
5775	5558	5444	6,08	2,09
6275	5915	5700	10,09	3,77
7062	6650	6376	10,76	4,30

Table 5.14: Gains of the power output caused by sub-cooling

Expansion valve brings average gains in heating capacity 5,7 %.  
 Capillary brings average gains in heating capacity 3 %.

### 6.1.2 Electric consumptions comparison

According to expectation, there are small differences in power consumption  $P_{el}$ . That means increased heating capacities is going to be possible to see also in COP's values. If sub-cooling would be higher than the temperature difference of heating water, it would increase also condensation pressures. With higher condensation pressures would increase also electricity consumption. It would lead to instability of refrigeration, decreasing of COP and would bring the risk of high pressure shut down.

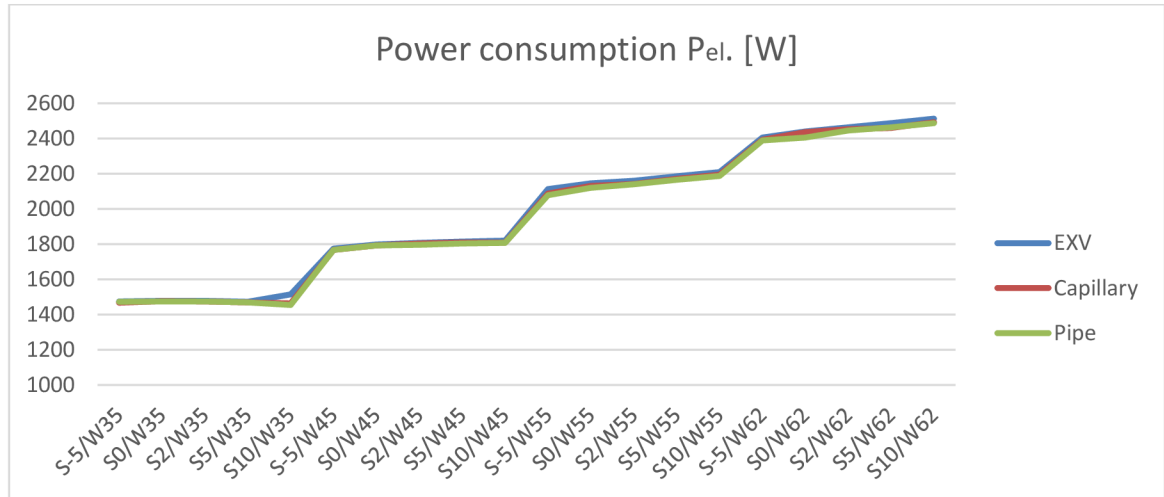

Graph 5.11: Comparison of  $P_{el}$ .

### 6.1.3 Sub-cooling comparison

In the following graph it is possible to see amount of sub-cooling during rating test in all three variants. Sub-cooling performed by capillary is copying the velocities of the pressure drop. The measurement shows us that also smaller sub-cooling is able to increase heating capacities of the heat pump, but the high sub-cooling is also able to decrease heating capacities.

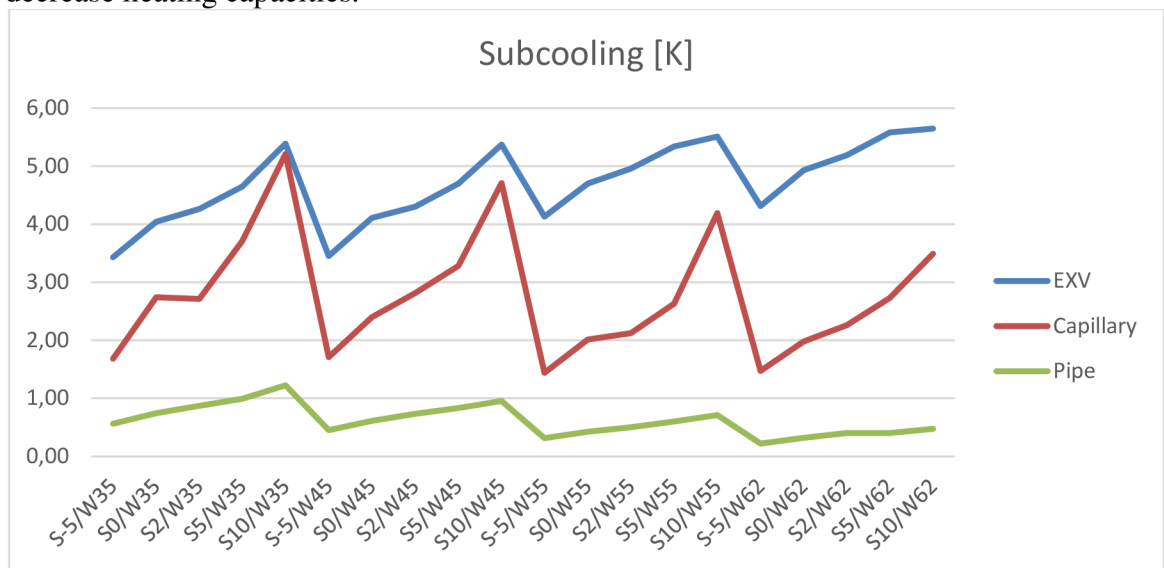

Graph 5.12: Comparison of sub-coolings

### 6.1.4 COP's comparison

The final comparison is going to be comparison of COPs. Graphs are created with the same source temperatures -5 °C, 0°C, 10°C.

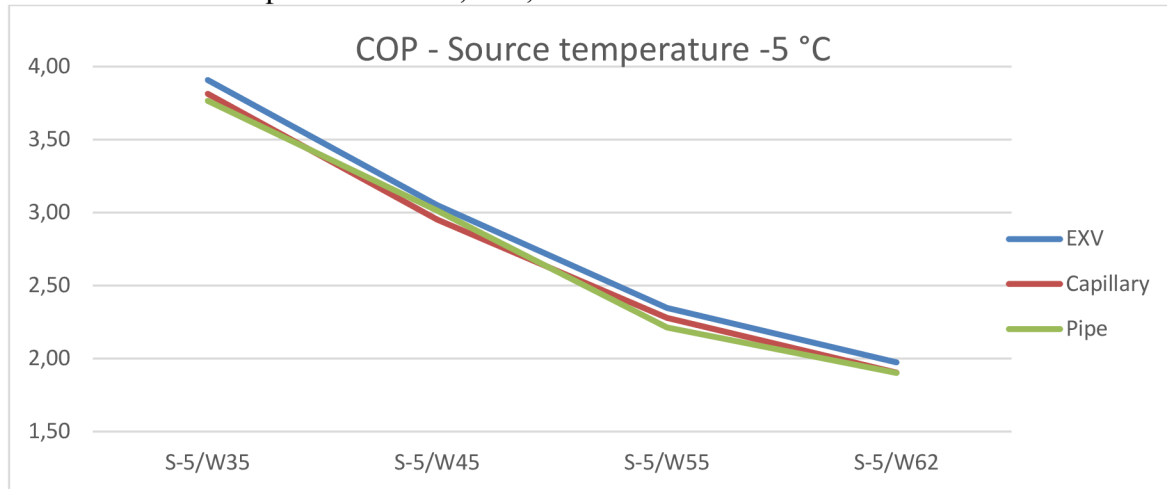

Graph 5.13: Comparison of COPs with source temperature -5°C

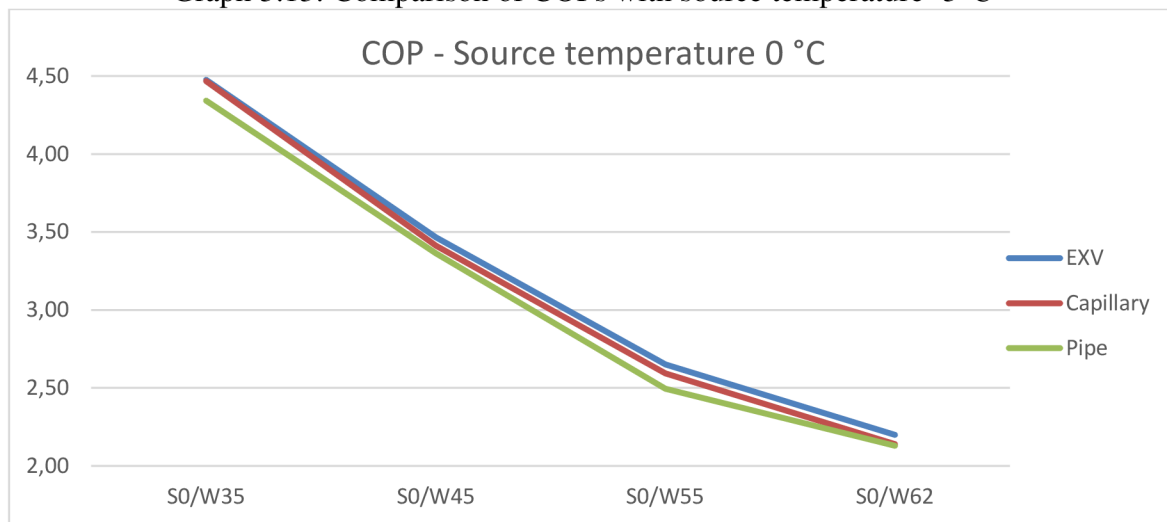

Graph 5.14: Comparison of COPs with the source temperature 0°C

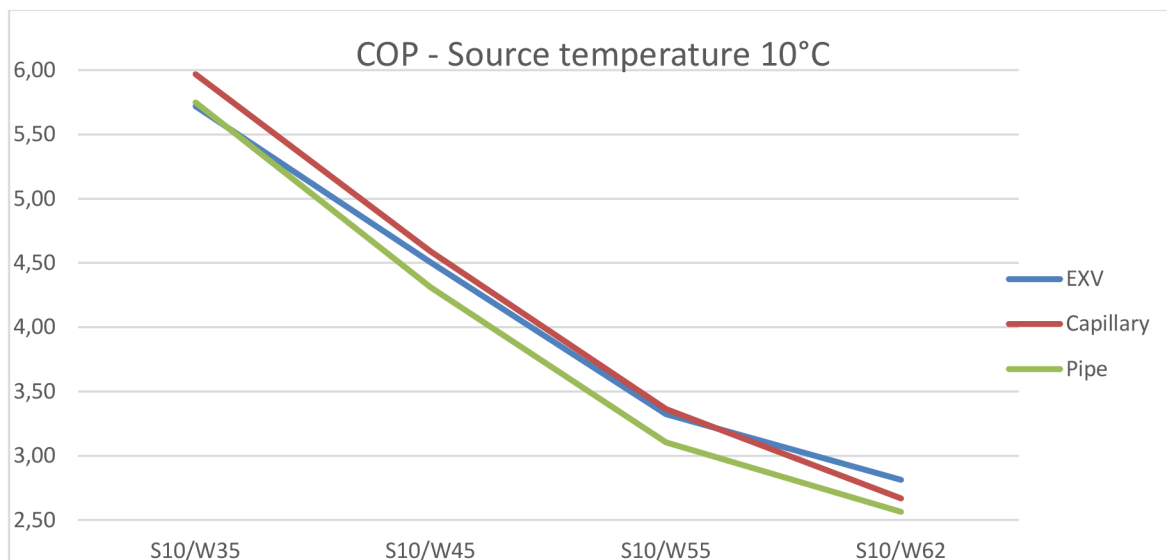

Graph 5.15: Comparison of COPs with the source temperature 10°C

COP's comparison shows the same result like comparison of the heating capacities. Now it is possible to compare the percentual gains on the COP's according to sub-cooling:

pint	EXV COP	Cap COP	Pipe COP	EXV incr.	EXV Sub	Cap incr.	Cap sub
				%	[K]	%	[K]
S-5/W35	3,91	3,81	3,77	3,83	3,43	1,28	1,68
S0/W35	4,48	4,47	4,34	3,08	4,04	2,86	2,74
S2/W35	4,73	4,67	4,63	2,29	4,26	0,98	2,71
S5/W35	5,18	5,14	4,97	4,21	4,65	3,40	3,71
S10/W35	5,72	5,97	5,75	-0,52	5,39	3,80	5,21
S-5/W45	3,05	2,95	3,01	1,25	3,45	-2,01	1,71
S0/W45	3,47	3,41	3,36	3,06	4,11	1,49	2,40
S2/W45	3,64	3,59	3,55	2,71	4,30	1,26	2,81
S5/W45	3,95	3,89	3,81	3,67	4,70	2,15	3,28
S10/W45	4,50	4,59	4,31	4,51	5,37	6,47	4,71
S-5/W55	2,35	2,28	2,21	6,08	4,13	3,01	1,44
S0/W55	2,65	2,59	2,49	6,27	4,70	3,91	2,01
S2/W55	2,78	2,66	2,59	7,58	4,96	2,96	2,12
S5/W55	3,01	2,90	2,78	8,39	5,34	4,31	2,63
S10/W55	3,32	3,36	3,10	7,01	5,51	8,30	4,19
S-5/W62	1,97	1,90	1,90	3,79	4,31	0,05	1,47
S0/W62	2,20	2,14	2,13	3,28	4,93	0,50	1,98
S2/W62	2,34	2,27	2,23	5,35	5,19	1,80	2,26
S5/W62	2,52	2,40	2,31	9,07	5,58	3,90	2,73
S10/W62	2,81	2,67	2,56	9,66	5,65	4,05	3,49

Table 5.15: Gains of the COP caused by sub-cooling

Average values Expansion Valve:

Average increase of COP in % = **4,73 %**

Average sub-cooling = **4,7 K**

Average values Capillary:

Average increase of COP in % = **2,72 %**

Average sub-cooling = **2,76 K**

Form the following results it is possible to say, that each **1 K** of sub-cooling is able to increase overall COP **1 %** higher. But as it was said, condition that sub-cooling can't be higher than water temperature difference in evaporator has to be accomplished.

## 6.2 Discussion

Main advantage of sub-cooling is increasing of heating capacity of the same heat pump. That means, with the same components it is possible to get higher power output  $P_{\text{heating}}$  from the same heat pump. Thanks to this, heat pumps reach better COPs and can be smaller. But this system has also its disadvantages, because it needs improved regulation and more complicated development.



---

### 6.2.1 Electronic Expansion valve

#### Advantages

In the first variant was used electronic expansion valve for creating a pressure drop that caused sub-cooling. This system brings the best results in increasing heating capacity. COP was also increased. The next advantage of this system is that pressure drop created by expansion valve can be adjusted so it is possible to still get the best values of sub-cooling. This advantage is fully used mainly in higher compressor speeds and in high mass flows of refrigerant.

#### Disadvantages

But on the other side, the second expansion valve is increasing the production costs of the heat pump and it also influences the final cost of the machine. This system needs complicated regulation. In the heating circuit are two regulated elements: over-heating expansion valve and sub-cooling expansion valve. Here is the chance that these two elements start to influence each other in starting of the heat pump and it can cause instability in the refrigerant circuit. This implies that the system with two expansion valves needs scrupulous testing in the various conditions and also edge conditions which are specific by used compressor. After this tests can be heat pump stated for selling.

### 6.2.2 Capillary

#### Advantages

Capillary also brings good results of a power output  $P_{\text{heating cap}}$  increasing. This variant is cheaper and doesn't need complicated regulation like the first variant. It gives satisfactory results of increasing heating capacity. Those results are comparable with the results of the expansion valve. So it means also this variant is possible to use in some specific types of brine source or water source heat pumps.

#### Disadvantages

But it is necessary to measure heat pump characteristics before capillary calculation. Element with stable a pressure drop characteristic is causing the problems in the heat pump's starts. After turning off the heat pump, refrigerant is cumulating in the place with the lowest temperature and it is the evaporator. During the start of the compressor wet steams are sucked in. The safety valve of compressor starts to open and close. The result of this are changes in the flow rate. Because of the changing mass flow, pressure drop of the capillary starts to change in wide range. This can cause increasing of the condensation pressure and critical shut down of the machine caused by the high pressure safety sensor.

### 6.2.3 Pipe, zero sub-cooling

#### Advantages

When the heat pump runs with no sub-cooling, refrigerant circuit regulation can be the simplest. Also refrigeration is very stable and heat pump can run also in edge conditions of the compressor for a long time.

#### Disadvantages

But in this variant the capacity of the heat pump is not fully used. Another disadvantage of this system is that the condensation of the refrigerant doesn't have to be completed. It could lead to filling the receiver wet steams of refrigerant instead of liquid.

---

When the heat pump is running longer in these conditions, the receiver becomes empty. The result is that in front of heating expansion valve appears refrigerant with bubbles inside. This could also lead to emergency shutdown of the machine. That means the heat pump needs higher filling of refrigerant.

---

## 7 Conclusion

The heat pumps are slowly pushing out of market conventional types of heating like various types of furnaces and electricity. They are becoming one of the main heating systems in Europe. In the year 2014 nearly 796.000 units have been installed in Europe and in Germany approximately every third heating system in a new building is a heat pump. Heat pumps are the ecological way of heating, but this is not the only reason for the application and growing market with the heat pumps. The advantages of this heating system are no demands of fuels, also saving the money for heating and hot water preparation and a high level of comfortable living that heat pumps can offer. But the higher request of heat pumps brings new producers on the market and creates pressure on development to increase efficiency of heat pumps and also to decrease production costs.

One method for increasing heat pump's efficiency is using sub-cooling of the refrigerant during the condensation in the condenser on the secondary side of heating circuit during hot water preparation. Sub-cooling brings increasing of heating capacity. Gains of heat gained from the refrigerant are caused by cooling the refrigerant under condensation temperature. Sub-cooling is reached by the creation of a pressure drop at the outlet of the condenser. Pressure drop is created by electronic expansion valve. This pressure drop is possible to achieve by capillary that provides friction pressure drop, thanks high speed of liquid refrigerant inside of capillary. Capillary was calculated from the pressure drop of the electronic expansion valve. From the comparison of the results is clear, that sub-cooling brings increasing of heating capacities of the heat pump.

The results show that expansion valve can be replaced by the capillary. But it is necessary to consider the disadvantages of using capillary such as changing sub-cooling in various points of conditions that depends on refrigerant mass flow. Also, changes in compressor speed are influencing mass flow so the capillary has to be designed for lower pressure drops and it is ideal just in a narrow range of operations points. That means, capillary is not able to bring such good results like expansion valve. Capillary can be used in heat pumps which are running with stable source temperatures and narrow range of heating temperatures. This system saves production costs because of the lower cost of capillary than an electronic expansion valve. Capillary also brings the advantage of using less complicated regulation of the refrigerant circuit.

---

## List of sources

1. Energia. *Ako si vybrať najvhodnejší kotol pre vykurovanie domu?* [online]. 2011 [cit. 2016-04-18]. Available at: <http://energia.dennikn.sk/poradime-vam/zemny-plyn-a-ropa/ako-si-vybrat-najvhodnejsi-kotol-pre-vykurovanie-domu/3996/>
2. ŽILINSKÝ, Juaraj a kolektív. *Vykurovanie rodinného domu* [online]. 2011 [cit. 2016-04-19]. Available at: <http://www.kotol-kotly.sk/vykurovanie-clanok-osveta-princip-fungovania-uspora-princip-uzitocne-rady/>
3. ŽERAVÍK, Antonín. *Stavíme tepelné čerpadlo*. Prerov: EURO-PRINT Prerov spol. s. r. o., 2003. ISBN 80-239-0275-X.
4. COMPANY LITERATURE. *Heat pump manual*. 2014.
5. COMPANY LITER., Alfa Laval. *Das Handbuch für Plattenwärmeübertrager in der Kälte- und Klimatechnik*. 3rd. S. Bonifacio: Tipolitografia Faltracco, 1999. ISBN 91-630-5853-7.
6. BROŽ, Jiří, Zdeněk ČEJKA, Zdeněk FENCL, et al. *Chladicí a klimatizační technika*. Praha: Svaz chladiců a klimatizační techniky s.r.o, 2012.
7. Smart Clima. *Copper capillary tube*. [online]. 2014 [cit. 2016-05-24]. Available at: <http://hvacparts02.blogspot.sk/2014/02/copper-capillary-tube.html>
8. IDELCHIK, I.E. *Handbook of Hydraulic Resistance*. 3rd. Danbury: Begell House, 1996. ISBN 8179921182.
9. Neutrium. *PRESSURE LOSS FROM FITTINGS – EXPANSION AND REDUCTION IN PIPE SIZE* [online]. 2012 [cit. 2016-05-18]. Available at: [https://neutrium.net/fluid\\_flow/pressure-loss-from-fittings-expansion-and-reduction-in-pipe-size/](https://neutrium.net/fluid_flow/pressure-loss-from-fittings-expansion-and-reduction-in-pipe-size/)
10. REINBERK, Zdenek. *Přibližný výpočet tlakové ztráty třením v potrubí*. *TZB-Info* [online]. 2002 [cit. 2016-05-18]. Available at: <http://www.tzb-info.cz/1002-priblizny-vypocet-tlakove-zraty-trenim-v-potrubi>

## List of symbols

Heating Capacity	$P_{\text{heating}}$	W
Electricity consumption	$P_{\text{el}}$	W
Condenser entry (water side)	$t_{\text{win}}$	°C
Condenser return (water side)	$t_{\text{wout}}$	°C
Mass flow of the water	$V_{\text{flow}}$	m <sup>3</sup> /h
Absolute condensation pressure	$p_{\text{cond. abs}}$	Bar
Hot gas temperatures	$t_{\text{hotgas}}$	°C
Condensate temperatures	$t_{\text{condensate}}$	°C
Condensation temperature	$t_{\text{cond}}$	°C
Sub-cooling of refrigerant	$T_{\text{sub-cooling}}$	K
Pressure drop of expansion valve	$\Delta p_{\text{exv}}$	Bar
Coefficient of Performance	COP	-
Source temperature	$t_s$	°C
Heating water temperature	$t_w$	°C
Temperature of hot gas	$t_{\text{hot gas}}$	°C
Condensation temperature	$t_{\text{cond.}}$	°C
Enthalpy of hot gas	$h_{\text{hot gas}}$	kJ/kg
Enthalpy of condensate	$h_{\text{condensate}}$	kJ/kg
Mass flow of refrigerant	$m_{\text{flow}}$	kg/s
Dynamic viscosity of refrigerant	$\mu$	kg/(m·s)
Density of refrigerant	$\rho$	kg/m <sup>3</sup>
Kinematic viscosity of refrigerant	$\nu$	m <sup>2</sup> /s
Inner diameter of capillary	$D_{\text{in}}$	mm
Inner roughness of capillary	$k$	mm
Relative Roughness	$\varepsilon$	-
Speed of refrigerant in capillary	$v$	m/s
Reynolds number	Re	-
Friction factor	$\lambda$	-
Inner diameter of pipe	$D_{\text{pipe}}$	m
Local pressure loss	$p_z$	Pa
Specific number of inlet	$K_{\text{in}}$	
Correction factor of inlet	C	
Specific number of outlet	$K_{\text{out}}$	
Inlet pressure losses	$p_{z\text{in}}$	Pa
Outlet pressure losses	$p_{z\text{out}}$	Pa
Sum of the local pressure losses	$p_{\text{loc}}$	Bar
Safety condition of calculation	$p_{\text{safety}}$	Bar
Pressure for capillary calculation	$\Delta p$	Pa
Length of capillary	$l$	m
Friction pressure loss of capillary	$p_{\text{cap}}$	Bar
Total capillary pressure loss	$\Delta p_{\text{calc}}$	Bar
Temperature difference of water	$\Delta T_{\text{cond}}$	K
Temperature difference of brine	$\Delta T_{\text{evap}}$	K
Measured pressure drop of capillary	$\Delta p_{\text{meas.}}$	Bar
Difference of condensation temperatures	$dT_{\text{cond}}$	K
Difference of sub-cooling temperatures	$dT_{\text{sub}}$	K



---

## List of pictures

Picture 3.1: Gas furnace and pellet furnace for heating buildings.....	13
Picture 3.2: Local electrical heater.....	14
Picture 3.3: Solar collector for hot water preparation.....	14
Picture 4.1: Plate heat exchanger.....	18
Picture 4.2: Lamella heat exchanger with description.....	18
Picture 4.3: Condenser function.....	19
Picture 4.4: Evaporator function with connection.....	19
Picture 4.5: Piston compressor.....	21
Picture 4.6: Scroll compressor.....	21
Picture 4.7: Thermostatic expansion valve.....	22
Picture 4.8: Electronic expansion valve.....	23
Picture 4.9: Receiver function in the refrigerant circuit.....	25
Picture 4.10: Four way valve function.....	26
Picture 4.11: Sight glass with humidity indicator.....	27
Picture 4.12: Principle and example of outside air source unit.....	28
Picture 4.13: Principle of water source heat pump with two wells.....	29
Picture 4.14: Principle of ground source heat pump with area collector.....	30
Picture 5.1: Tested heat pump connected to test bench.....	32
Picture 5.2: Schema of test bench.....	33
Picture 5.3: Schema of the heat pump and sensors connection.....	34
Picture 5.4: Input values into EES for state variables calculation.....	38
Picture 5.5: Calculated values from EES.....	39
Picture 5.6: Catalogue of capillary dimensions.....	41
Picture 5.7: Input values into EES for friction factor calculation.....	43
Picture 5.8: Friction factor calculation from EES.....	43
Picture 5.9: Connection of the capillary.....	45
Picture 5.10: Photo of connections of constructed capillary.....	48
Picture 5.11: Photo of constructed capillary.....	48

## List of graphs

Graph 4.1: p – h diagram of R410A refrigerant.....	25
Graph 5.1: Refrigerant circuit drawn in p-h diagram of R410A with sub-cooling showed by the line 5-6 .....	31
Graph 5.2: Rating test of the heat pump with the electronic expansion valve.....	36
Graph 5.3: Pressure drop of expansion valve and sub-cooling during the rating test.....	38
Graph 5.4: Calculated velocities of refrigerant inside of the capillary.....	42
Graph 5.5: Calculated $\Delta p_{exv}$ of the capillary compared with $\Delta p_{calc}$ of expansion valve...48	48
Graph 5.6: Rating test of the heat pump with capillary.....	50
Graph 5.7: Rating test of the heat pump with the pipe.....	52
Graph 5.8: Comparison of $P_{heating}$ with the source temperature $-5^{\circ}\text{C}$ .....	53
Graph 5.9: Comparison of $P_{heating}$ with the source temperature $0^{\circ}\text{C}$ .....	53
Graph 5.10: Comparison of $P_{heating}$ with the source temperature $10^{\circ}\text{C}$ .....	54
Graph 5.11: Comparison of $P_{el}$ . .....	55
Graph 5.12: Comparison of sub-coolings.....	55
Graph 5.13: Comparison of COPs with the source temperature $-5^{\circ}\text{C}$ .....	56
Graph 5.14: Comparison of COPs with the source temperature $0^{\circ}\text{C}$ .....	56
Graph 5.15: Comparison of COPs with the source temperature $10^{\circ}\text{C}$ .....	56

---

## List of tables

Table 5.1: Sensors of the test bench.....	33
Table 5.2: Sensors connected in heat pump.....	34
Table 5.3: Data demanded for measurement.....	35
Table 5.4: Rating test of the heat pump with electronic expansion valve.....	36
Table 5.4: Demanded data for capillary calculation.....	37
Table 5.5: Values of the state variables calculated in EES.....	40
Table 5.6: Calculated values of Friction factor from EES.....	44
Table 5.7: Pressure losses caused by inlet and outlet.....	46
Table 5.8: Values needed for capillary calculation.....	46
Table 5.9: Calculated pressure drops of the capillary in whole range of rating test.....	47
Table 5.10: Rating test of the heat pump with capillary.....	49
Table 5.11: Differences in calculated and measured pressure drop.....	50
Table 5.12: Comparison of the condensation temperatures and sub-cooling temperatures.....	51
Table 5.13: Rating test of the heat pump with the pipe.....	52
Table 5.14: Gains of the power output caused by sub-cooling.....	54
Table 5.15: Gains of the COP caused by sub-cooling.....	57