



BRNO UNIVERSITY OF TECHNOLOGY

VYSOKÉ UČENÍ TECHNICKÉ V BRNĚ

FACULTY OF ELECTRICAL ENGINEERING AND COMMUNICATION

FAKULTA ELEKTROTECHNIKY
A KOMUNIKAČNÍCH TECHNOLOGIÍ

DEPARTMENT OF RADIOENGINEERING

ÚSTAV RADIOELEKTRONIKY

COEXISTENCE OF LORA AND WI-FI IN THE RF BAND 2.4 GHZ

KOEXISTENCE SYSTÉMŮ LORA A WI-FI V RF PÁSMU 2.4 GHZ

MASTER'S THESIS

DIPLOMOVÁ PRÁCE

AUTHOR

AUTOR PRÁCE

Bc. Filip Kaučiarik

SUPERVISOR

VEDOUCÍ PRÁCE

doc. Ing. Ladislav Polák, Ph.D.

BRNO 2020



Diplomová práce

magisterský navazující studijní obor **Elektronika a sdělovací technika**

Ústav radioelektroniky

Student: Bc. Filip Kaučiarik

ID: 174325

Ročník: 2

Akademický rok: 2019/20

NÁZEV TÉMATU:

Koexistence systémů LoRa a Wi-Fi v RF pásmu 2.4 GHz

POKYNY PRO VYPRACOVÁNÍ:

V teoretické části práce se seznámte bezdrátovými komunikačními technologiemi LoRa a IEEE 802.11 (Wi-Fi). Definujte radiofrekvenční (RF) pásmo, ve kterém tyto systémy mohou koexistovat. Definujte typy možných koexistenčních scénářů. Navrhnete tzv. měřicí testbed pro měření koexistence systémů využívající technologie LoRa a Wi-Fi a vhodnou metodiku pro vyhodnocení výsledků z měření.

V experimentální části práce provedte laboratorní měření dříve definovaných koexistenčních scénářů. Při měření uvažujte různé systémové parametry obou bezdrátových systémů. Pro vyhodnocení odolnosti rušeného bezdrátového systému vůči rušícímu zvolte vhodnou metodiku. Získané výsledky detailně vyhodnoťte. Výsledky měření v rámci možností porovnejte s teoretickými předpoklady a dostupnou literaturou. Navrhněte laboratorní úlohu pro měření koexistence systémů LoRa a Wi-Fi a připravte vzorové vypracování navržené úlohy.

DOPORUČENÁ LITERATURA:

[1] Semtech. SX1280 Long Range, Low Power 2.4 GHz Transceiver. Application Note: Wi-Fi Immunity of LoRa® at 2.4 GHz. Application Note, 20 pages. June 2017.

[2] POTOČŇAK, Martin. Koexistence systémů LTE a LoRa v ISM pásmu 2.4 GHz. Brno: Vysoké učení technické v Brně, Fakulta elektrotechniky a komunikačních technologií. Ústav radioelektroniky, 2019. 55 s., 6 s. příloh. Bakalářská práce. Vedoucí práce: doc. Ing. Ladislav Polák, Ph.D.

Termín zadání: 3.2.2020

Termín odevzdání: 28.5.2020

Vedoucí práce: doc. Ing. Ladislav Polák, Ph.D.

prof. Ing. Tomáš Kratochvíl, Ph.D.
předseda oborové rady

UPOZORNĚNÍ:

Autor diplomové práce nesmí při vytváření diplomové práce porušit autorská práva třetích osob, zejména nesmí zasahovat nedovoleným způsobem do cizích autorských práv osobnostních a musí si být plně vědom následků porušení ustanovení § 11 a následujících autorského zákona č. 121/2000 Sb., včetně možných trestněprávních důsledků vyplývajících z ustanovení části druhé, hlavy VI. díl 4 Trestního zákoníku č.40/2009 Sb.

Abstract

This diploma thesis deals with the study of coexistence that can occur between the LoRa and Wi-Fi systems in the non-licensed 2.4 GHz ISM band. The theoretical part of this thesis focuses on the description of the physical (PHY) layer of both systems. There are also defined coexistence scenarios that can occur between LoRa and Wi-Fi systems in common radiofrequency (RF) bands. In the experimental part of this thesis, an appropriate laboratory workplace is proposed and realized to measure different coexistence scenarios between LoRa and Wi-Fi. The functionality of the proposed concept and the adopted measurement methodology are verified by a set of experimental measurements. Measurement results are evaluated and discussed in detail. Finally, a laboratory work for education purposes in the Laboratory of Mobile and Wireless Communications is prepared.

Keywords

LoRa, Wi-Fi, coexistence of wireless systems, interference, RF measurement, PER, ISM band 2.4 GHz

Abstrakt

Diplomová práca sa zaoberá štúdiom koexistencie, ktorá môže nastať medzi bezdrôtovými komunikačnými systémami LoRa a Wi-Fi v bezlicenčnom ISM pásme 2,4 GHz. V teoretickej časti práce sú stručne popísané fyzické vrstvy oboch systémov. Následne sú definované spoločné frekvenčné pásma a koexistenčné scenáre, ktoré môžu vzniknúť medzi uvažovanými systémami v spoločnom rádiových frekvenčnom (RF) pásme. V experimentálnej časti práce je prezentované laboratórne meracie pracovisko, ktoré bolo navrhnuté na meranie rôznych koexistenčných scenárov medzi technológiou LoRa a Wi-Fi. Funkčnosť navrhutej koncepcie je overená experimentálnym meraním. Výsledky meraní sú detailne komentované a prezentované. Je navrhnutá laboratórna úloha a vzorový protokol pre vzdelávacie účely v Laboratóriu Mobilných a Bezdrôtových komunikácií.

Kľúčové slová

LoRa, Wi-Fi, koexistencia bezdrôtových systémov, interferencia, RF meranie, PER, ISM pásmo 2,4 GHz

Rozšírený abstrakt

V dnešnej dobe môžeme pozorovať implementáciu viacerých bezdrôtových systémov a sietí do reálneho sveta. Myšlienka tzv. „Chytrých miest“ (Smart Cities) sa stáva reálnejšou viac ako kedy predtým. Spolu s tým zároveň dochádza k implementácií viacerých bezdrôtových systémov do tohoto konceptu. Dopyt po zariadeniach tzv. „Internetu vecí“ (IoT), ako sú senzory teploty, pohybu, ovládače osvetlenia, klimatizácie alebo bezdrôtové siete pre bezpečnostné účely rastie. Špeciálne miesto v koncepte chytrých miest má využitie tzv. „Low-Power Wide-Area Networks“ (LPWAN) sietí a jedna z technológií úzko spojená práve s LPWAN a IoT je „Long Range“ (LoRa) [1]. Systém LoRa plní viacero požiadaviek na siete LPWAN vďaka svojej nízkej energetickej spotrebe, veľkému dosahu signálu, vysokej odolnosti voči rušeniu a nízkej šírke pásma. LoRa bola pôvodne vyvinutá pre sub-GHz pásmo.

Na trh boli nedávno uvedené nové LoRa moduly schopné pracovať a realizovať komunikáciu v tzv. „Industry, Scientific and Medical“ (ISM) pásme 2,4 GHz. Toto rádiový frekvenčné (RF) pásmo je primárne využívané sieťami „Wireless Local Area Networks“ (WLANs), medzi užívateľmi známymi aj ako „Wireless-Fidelity“ (Wi-Fi) siete. Masívne používanie tohto bezlicenčného RF pásma systémom LoRa môže v budúcnosti viesť k nechcenej koexistencii so sieťami Wi-Fi. Aktuálne je štúdium koexistencie veľmi dôležité z dôvodu, že bezdrôtové systémy v súčasnosti môžu využívať spoločné RF pásmo. Pre takýto výskum je neoddeliteľnou súčasťou navrhnutie vhodného meracieho zapojenia a metodiky merania.

Táto diplomová práca sa zameriava na meranie koexistencie, ktorá môže nastať medzi bezdrôtovými systémami LoRa a Wi-Fi (štandard IEEE 802.11) v pásme 2.4 GHz. Práca pozostáva zo siedmych kapitol.

Úvod do práce a jej problematiky je uvedený v kapitole 1. Kapitola 2 pojednáva o rozdelení sietí do skupín podľa komplexnosti. Systémy LoRa a Wi-Fi sú stručne popísané v kapitole 3 a 4 z pohľadu fyzickej vrstvy, frekvenčných pásiem, v ktorých pracujú a v krátkom predstavení linkovej vrstvy. Zároveň je v kapitole 5 stanovené spoločné RF pásmo a koexistenčné scenáre, pri ktorých tieto systémy môžu koexistovať.

V kapitole 6 je predstavené meracie zapojenie, ktoré bolo navrhnuté a zrealizované v laboratóriu mobilných komunikácií, na Ústave rádioelektroniky (UREL) FEKT VUT v Brne, pričom boli využité meracie zariadenia a vybavenie zapožičané za týmto účelom zo spomenutého ústavu. Pre meracie účely a ďalšieho výskumu danej problematiky je navrhnutá vhodná metodika merania ktorá bola následne overená. Ako objektívne parametre sú použité Packet error ratio (PER) a Carrier-to-Interference ratio (C/I). Následne sú definované koexistenčné scenáre s cieľom skúmať systémové parametre

technológie LoRa, ktoré vykazujú najväčšiu odolnosť pri rušení interferenčným signálom.

Kapitola 7 obsahuje výsledky meraní, ich vyhodnotenie a detailnú prezentáciu. Merania sú vykonané pre niekoľko nastavení systémových parametrov technológií LoRa a Wi-Fi. Signál LoRa je rušený signálom Wi-Fi s rôznymi použitými parametrami (moduláciami). Zo získaných výsledkov je možné pozorovať značný vplyv systémových parametrov technológie LoRa, ako sú šírka pásma (označené v práci ako BW_{LoRa} , bandwidth of LoRa) alebo faktor rozprestretia (označené v práci ako SF_{LoRa} , spreading factor of LoRa) na robustnosť technológie LoRa a jej koexistenciu s Wi-Fi v spoločnom RF pásme. Ďalším skúmaným faktorom je vplyv frekvenčného posuvu rušiaceho Wi-Fi signálu, jeho výkonová úroveň, modulačná technika a použitá modulácia tohto signálu. Popis a výklad získaných výsledkov je uvedený v analýze merania.

Nakoniec, kapitola 8 obsahuje záver celej práce. Z daných výsledkov sa javí najodolnejšie (a najvhodnejšie z pohľadu koexistencie LoRa vs. Wi-Fi) konfigurácia signálu LoRa s vysokou hodnotou SF_{LoRa} a nízkou hodnotou BW_{LoRa} . Zároveň bola navrhnutá laboratórna úloha so vzorovým vypracovaním protokolu pre potreby predmetu Systémy mobilných komunikácií (MSMK).

Práca zároveň položila základ a možné smerovanie pre ďalší výskum v oblasti koexistencie systémov LoRa a Wi-Fi. Boli definované témy, ktoré by mohli byť z pohľadu ďalšieho výskumu zaujímavé. Za zmienku stojí meranie väčšieho množstva kombinácií systémových parametrov oboch systémov, „out-band“ koexistenčného scenáru či meranie v reálnych podmienkach.

Časť práce bola prezentovaná na študentskej konferencii EEICT 2020.

Bibliografická citácia:

KAUČIARIK, Filip. *Koexistence systémů LoRa a Wi-Fi v RF pásmu 2.4 GHz*. Brno, 2020, 60s., 11s. příloh. Dostupné také z: <https://www.vutbr.cz/studenti/zav-prace/detail/126128>. Diplomová práce. Vysoké učení technické v Brně, Fakulta elektrotechniky a komunikačních technologií, Ústav radioelektroniky. Vedoucí práce Ladislav Polák.

Prehlásenie

„Prehlasujem, že svoju diplomovú prácu na tému *Koexistence systémů LoRa a Wi-Fi v RF pásme 2.4 GHz* som vypracoval samostatne pod vedením vedúceho diplomovej práce a s použitím odbornej literatúry a ďalších informačných zdrojov, ktoré sú všetky citované v práci a uvedené v zozname literatúry na konci práce.

Ako autor uvedenej diplomovej práce ďalej prehlasujem, že v súvislosti s vytvorením tejto diplomovej práce som neporušil autorské práva tretích osôb, hlavne som nezasiahol nedovoleným spôsobom do cudzích autorských práv osobnostných a som si plne vedomý následkov porušenia ustanovení § 11 a nasledujúcich autorského zákona č. 121/2000 Zb., vrátane možných trestnoprávných dôsledkov vyplývajúcich z ustanovení časti druhej hlavy VI. dielu 4 Trestného zákonníku č. 40/2009 Zb.

V Brne dne: **24.05.2020**

.....
podpis autora

Pod'akovanie

Ďakujem vedúcemu diplomovej práce Doc. Ing. Ladislavovi Polákovi, Ph.D. za účinnú metodickú, pedagogickú a odbornú pomoc a ďalšie cenné rady pri spracovaní mojej diplomovej práce. Zároveň ďakujem všetkým kolegom, rodine, priateľom a spolubývajúcim, ktorí ma pri spracovaní tejto diplomovej práce plne podporovali.

V Brne dne: **24.05.2020**

.....
podpis autora

Contents

1.	Introduction.....	14
2.	Wireless Local Area and wide area networks (WLAN/WWAN).....	15
3.	Lora.....	16
3.1	Introduction.....	16
3.1.1	Complementarity with other wireless standards.....	16
3.2	Frequency bands, channels, and architecture.....	17
3.2.1	Frequency bands and channels.....	17
3.2.2	Network architecture.....	17
3.3	PHY layer.....	17
3.3.1	PHY parameters.....	18
3.3.2	LoRa Frame.....	20
3.4	LoRaWAN.....	20
3.4.1	LoRaWAN end-device classes.....	20
4.	IEEE 802.11 (WLAN).....	22
4.1.1	802.11b.....	22
4.1.2	802.11n.....	23
4.2	Physical layer.....	24
4.2.1	Spread Spectrum (SS).....	24
4.2.2	Frequency Hoping Spread Spectrum (FHSS).....	24
4.2.3	Direct Sequence Spread Spectrum (DSSS).....	25
4.2.4	Orthogonal Frequency Division Multiplexing (OFDM).....	25
4.3	Media Access Control (MAC) Layer.....	26
4.3.1	Attributes of MAC.....	26
4.4	RF bands and channels.....	26
5.	LoRa and WLAN in the 2.4 GHz ISM Band- Coexistence scenarios.....	28
5.1	Coexistence scenarios.....	28
5.1.1	Coexistence.....	28
5.1.2	Coexistence scenarios.....	29
6.	Measurement setup and methodology.....	30
6.1	Measurement Testbed.....	30
6.1.1	WiMOD LR Studio.....	32
6.2	Methodology.....	34

6.2.1	Measured parameters	34
6.2.2	Methodology of measurement	34
7.	Experimental Measurements	37
7.1	LoRa vs. Wi-Fi (802.11b)	38
7.1.1	The IEEE 802.11b signal using of CCK (DBPSK) modulation	38
7.1.2	The IEEE 802.11b signal using of CCK (DQPSK) modulation.....	41
7.2	LoRa vs. Wi-Fi (802.11g)	43
7.2.1	The IEEE 802.11g signal using of PBCC (DBPSK) modulation	43
7.2.2	The IEEE 802.11g signal using of PBCC (8PSK) modulation.....	45
7.2.3	The IEEE 802.11g signal using of OFDM (BPSK) modulation.....	47
7.3	LoRa vs. Wi-Fi (802.11n)	49
7.3.1	The IEEE 802.11n signal using of OFDM (64QAM) modulation	49
7.4	Summary of the results and comparison with related works	52
8.	Conclusion.....	55
9.	References	56

List of abbreviations and symbols

Abbreviations:

16-QAM	...	16-Quadrature Amplitude Modulation
64-QAM	...	64-Quadrature Amplitude Modulation
ACI	...	Adjacent Channel Interference
ADR	...	Adaptable Bit Rates
BPSK	...	Binary Phase Shift Keying
BW	...	Bandwidth
CCI	...	Co-Channel Interference
CCCS	...	Co-Channel Coexistence Scenario
C/I	...	Carrier-to-Interference Ratio
CKK	...	Complementary Code Keying
CR	...	Code Ratio
CRC	...	Cyclic Redundancy Check
CSS	...	Chirps Spread Spectrum
DL	...	Downlink
DSSS	...	Direct Sequence Spread Spectrum
ETSI	...	European Telecommunications Standards Institute
FEC	...	Forward Error Correction
FLRC	...	Fast Long Range Communication
FHSS	...	Frequency Hoping Spread Spectrum
FSK	...	Frequency Shift Keying
GB	...	Guard Band
GFSK	...	Gaussian Frequency Shift Keying
GSM	...	Groupe Spécial Mobile
HCI	...	Health Control Interface
IBCS	...	In-Band Coexistence Scenario
IEEE	...	Institute of Electrical and Electronics Engineers
IoT	...	Internet of Things
ISI	...	Inter-Symbol Interferences
ISM	...	Industry, Scientific and Medical
LoRa	...	Long Range
LoRaWAN	...	LoRa Wide Area Network
LoS	...	Line-of-Sight
LPWAN	...	Low Power Wide Area Network
LTE	...	Long Term Evolution
MAC	...	Media Access Control Layer
MIMO	...	Multiple Input Multiple Output
OBCS	...	Out-Band Coexistence Scenario
OFDM	...	Orthogonal Frequency Division Multiplex
PER	...	Packet Error Rate
PHY	...	Physical Layer
PR	...	Protection Ratio
(D)/QPSK	...	(Differential)Quadrature Phase Shift Keying
RF	...	Radio Frequency
RSSI	...	Received Signal Strength Indicator
RTC	...	Real-time clock

SDM	...	Spatial Division Multiplex
SF	...	Spreading Factor
SNR	...	Signal-to-Noise Ratio
UHF	...	Ultra High Frequency
UL	...	Uplink
DREL	...	Department of radioelectronics
VoIP	...	Voice over IP
Wi-Fi	...	Wireless-Fidelity
WLAN	...	Wireless Local Area Network

Symbols:

BW_{LoRa}	...	Bandwidth of LoRa	[Hz]
BW_{Wi-Fi}	...	Bandwidth of Wi-Fi	[Hz]
BER	...	Bit Error Ratio	[-]
C	...	Carrier signal	[dBm]
C/I	...	Carrier-to-Interference Ratio	[dB]
CR	...	Code Ratio	[-]
GB	...	Guard band	[MHz]
I	...	Interference signal	[dBm]
PER	...	Packet Error Ratio	[%]
Rb	...	Raw data rate	[bits/s]
PR	...	Protection ratio	[dB]
RSSI	...	Received Signal Strength Indicator	[dBm]
SF_{LoRa}	...	Spreading Factor of LoRa	[-]
SNR	...	Signal-to-Noise Ratio	[dB]

List of figures

Figure 2-1 Distribution of wireless networks, (taken from [7])	15
Figure 3-1 LoRa PHY layer block diagram, (taken from [9])	18
Figure 4-1 802.11b PHY layer block diagram, (based on [18])	22
Figure 4-2 802.11n PHY layer block diagram, (based on [20])	23
Figure 4-3 802.11 channels at 2.4 GHz, (taken from [24])	27
Figure 5-1 Co-channel and In-band coexistence scenarios.....	29
Figure 5-2 Out-band coexistence scenario.....	29
Figure 6-1 Block schematic of a measurement setup	30
Figure 6-2 Measurement setup/testbed: 1. LoRa modules SK-iM282-A, 2. Signal Analyzer R&S FSQ 8, 3. Signal Generator R&S SMU200A, 4. PC, 5. Wilkinson power splitter, 6. Attenuator	31
Figure 6-3 WiMOD LR Studio: 1. “Radio services” bar (used for test), 2. “Configuration” bar, 3. “Extras” bar, 4. Information about connected modules, 5. “Radio configuration” (complete configuration of LoRa module), 6. “Event box.”	33
Figure 7-1 PR vs. Δf for $BW_{LoRa} = 200$ kHz LoRa vs. Wi-Fi (802.11b using CCK (DBPSK)), co-channel and in-band coexistence scenarios.....	40
Figure 7-2 PR vs. Δf for $BW_{LoRa} = 400$ kHz LoRa vs. Wi-Fi (802.11b using CCK (DBPSK)), co-channel and in-band coexistence scenarios.....	40
Figure 7-3 PR vs. Δf for $BW_{LoRa} = 1600$ kHz LoRa vs. Wi-Fi (802.11b using CCK (DBPSK)), co-channel and in-band coexistence scenarios.....	40
Figure 7-4 PR vs. Δf for $BW_{LoRa} = 200$ kHz LoRa vs. Wi-Fi (802.11b using CCK (DQPSK)), co-channel and in-band coexistence scenarios	42
Figure 7-5 PR vs. Δf for $BW_{LoRa} = 400$ kHz LoRa vs. Wi-Fi (802.11b using CCK (DQPSK)), co-channel and in-band coexistence scenarios	42
Figure 7-6 PR vs. Δf for $BW_{LoRa} = 1600$ kHz LoRa vs. Wi-Fi (802.11b using CCK (DQPSK)), co-channel and in-band coexistence scenarios	42
Figure 7-7 PR vs. Δf for $BW_{LoRa} = 200$ kHz LoRa vs. Wi-Fi (802.11g using PBCC (DBPSK)), co-channel and in-band coexistence scenarios.....	44
Figure 7-8 PR vs. Δf for $BW_{LoRa} = 400$ kHz LoRa vs. Wi-Fi (802.11g using PBCC (DBPSK)), co-channel and in-band coexistence scenarios.....	44

Figure 7-9 PR vs. Δf for $BW_{LoRa} = 1600$ kHz LoRa vs. Wi-Fi (802.11g using PBCC (DBPSK)), co-channel and in-band coexistence scenarios.....	44
Figure 7-10 PR vs. Δf for $BW_{LoRa} = 200$ kHz LoRa vs. Wi-Fi (802.11g using PBCC (8PSK)), co-channel and in-band coexistence scenarios	46
Figure 7-11 PR vs. Δf for $BW_{LoRa} = 400$ kHz LoRa vs. Wi-Fi (802.11g using PBCC (8PSK)), co-channel and in-band coexistence scenarios	46
Figure 7-12 PR vs. Δf for $BW_{LoRa} = 1600$ kHz LoRa vs. Wi-Fi (802.11g using PBCC (8PSK)), co-channel and in-band coexistence scenarios.....	46
Figure 7-13 PR vs. Δf for $BW_{LoRa} = 200$ kHz LoRa vs. Wi-Fi (802.11g using OFDM (BPSK)), co-channel and in-band coexistence scenarios	48
Figure 7-14 PR vs. Δf for $BW_{LoRa} = 400$ kHz LoRa vs. Wi-Fi (802.11g using OFDM (BPSK)), co-channel and in-band coexistence scenarios	48
Figure 7-15 PR vs. Δf for $BW_{LoRa} = 1600$ kHz LoRa vs. Wi-Fi (802.11g using OFDM (BPSK) , co-channel and in-band coexistence scenarios	48
Figure 7-16 PR vs. Δf for $BW_{LoRa} = 200$ kHz LoRa vs. Wi-Fi (802.11n using OFDM (64QAM)), co-channel and in-band coexistence scenarios	51
Figure 7-17 PR vs. Δf for $BW_{LoRa} = 400$ kHz LoRa vs. Wi-Fi (802.11n using OFDM (64QAM)), co-channel and in-band coexistence scenarios	51
Figure 7-18 PR vs. Δf for $BW_{LoRa} = 1600$ kHz LoRa vs. Wi-Fi (802.11n using OFDM (64QAM)), co-channel and in-band coexistence scenarios.....	51

List of tables

Table 3-1 LoRa frequencies according to country/region	17
Table 3-2 Possible values of LoRa parameters	19
Table 4-1 Parameters of 802.11b standard	23
Table 4-2 Parameters of 802.11n standard	23
Table 7-1 Co-channel and In-band scenario: system parameters of LoRa	37
Table 7-2 Selected combinations of LoRa parameters for each measurement scenario	37
Table 7-3 System parameters of IEEE 802.11b used in the measurement	38
Table 7-4 System parameters of IEEE 802.11g used in the measurement	43
Table 7-5 System parameters of IEEE 802.11n used in the measurement	49
Table 7-6 LoRa vs. Wi-Fi $PR_{10\%PER}$ for $\Delta f = 0$ MHz,	52
Table 7-7 LoRa vs. Wi-Fi $PR_{10\%PER}$ for $\Delta f = 6$ MHz.....	53
Table 7-8 LoRa vs. Wi-Fi $PR_{10\%PER}$ for $\Delta f = 10$ MHz	54

1. INTRODUCTION

Nowadays, we can recognize the implementation of many wireless systems and networks into real-life accessible by everyone. The idea of smart cities is getting real more than ever before. Demand for the Internet of Things (IoT) devices, like sensors of temperature, motion, controllers of light, air conditioning, or wireless networks for security purposes, is increasing. The use of Low-Power Wide-Area Networks (LPWAN) and one of the examples of these networks, Long Range (LoRa), has a special place in the concept of smart cities [1]. LoRa system fulfills several requirements of LPWAN networks thanks to its low power consumption, long-range, and small bandwidth. LoRa was initially developed for the sub-GHz band.

On the other hand, new LoRa-based transceivers have been developed, which enable us to realize the communication link in the 2.4 GHz Industry, Scientific and Medical (ISM) bands [1]. This radiofrequency (RF) band is primarily used by the established Wireless Local Area Networks (WLANs), known between users as Wireless-Fidelity (Wi-Fi). In the future, the massive utilization of this license-free RF band by LoRa can cause unwanted coexistence with Wi-Fi [2].

Currently, the study of the coexistence of different wireless systems is essential because, many times, they can share the same RF bands [3], [4]. For such research, appropriate measurement testbed and measurement methodology are vital. This thesis deals with the measurement of coexistence that can occur between the LoRa and Wi-Fi systems in the 2.4 GHz ISM band and the proposition of a laboratory work suitable for educational purposes.

This thesis work is organized as follows. The classification of networks is introduced in Section 2. The LoRa and Wi-Fi systems, considered in this work, are briefly introduced in Sections 3 and 4, respectively. This section is focused mainly on the physical (PHY) layers of both systems. The common RF bands for LoRa and Wi-Fi and possible coexistence scenarios, which can occur between these systems, are defined in Section 5. The proposed and realized measurement setup to measure and analyze different LoRa vs. Wi-Fi coexistence scenarios are introduced and described in Section 6. Section 7 contains the evaluation of the experimental measurements. Finally, this thesis is concluded in Section 8.

2. WIRELESS LOCAL AREA AND WIDE AREA NETWORKS (WLAN/WWAN)

Most considerable credit on definition and introduction of wireless networks had formed the Institute of Electrical and Electronics Engineers (IEEE) in 1963. IEEE is an international association of electrical engineers with members in more than 160 countries. Their work contains standard 802.3 (Ethernet), wireless standards like Bluetooth, Wireless Fidelity (Wi-Fi), WiMAX (all part of IEEE 802 standard family), or programming languages like VHDL or Verilog [5]. Wireless networks are defined as a structure of points connected without wire using RF waves as a communication medium through the air. We can divide wireless networks to more categories depending on the range:

- WPAN: Wireless personal area network** - up to 100 meters, Bluetooth and Zigbee
- WLAN: Wireless local area network** - range to 1000 meters, 802.11 standard (Wi-Fi)
- WMAN/WNAN: Wireless metropolitan/neighborhood area network** – range up to 10 km, WiMAX.
- WWAN: Wireless wide area network** – radius around tens of kilometers, average around 50 km. Long-range system: Long-Term Evolution (LTE) or Global System for Mobile Communications (GSM). Part of these are also low-power wide-area networks (LPWAN) and example: LoRa (Long Range) system.

The defined categories are displayed in the next figure (2.1). For this thesis, we are interested only in two specific groups, WLAN (and its representant 802.11) and LPWAN (LoRa) [2], [6] [7].

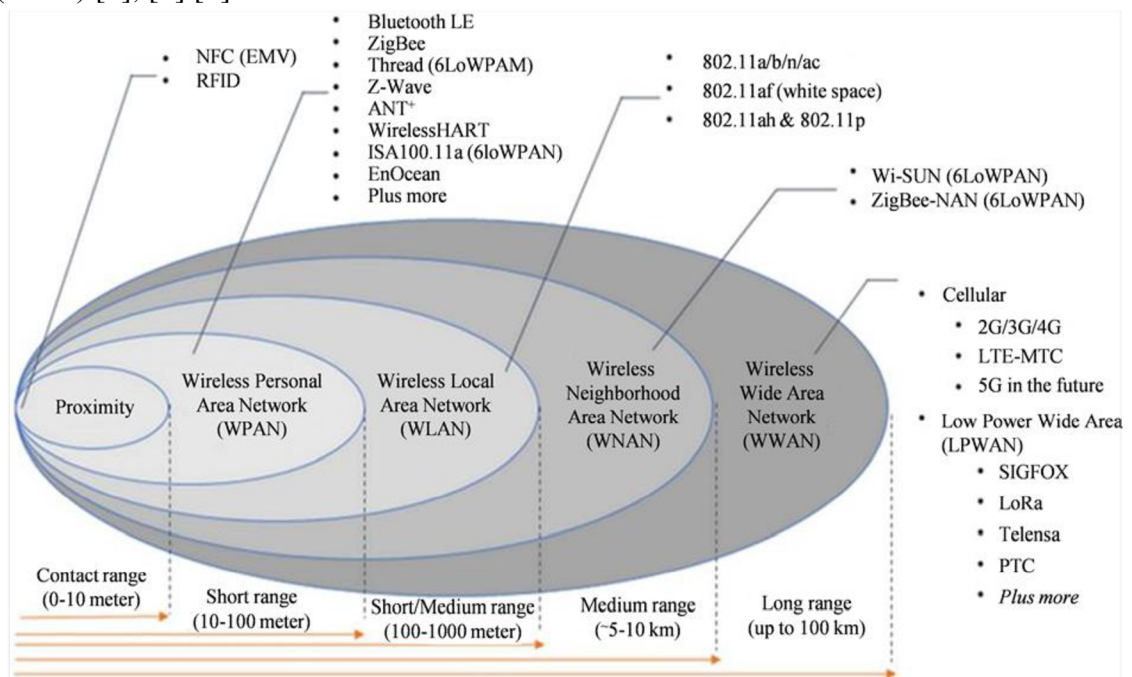

Figure 2-1 Distribution of wireless networks, (taken from [7])

3. LORA

3.1 Introduction

The LoRa technology is a product of Cycleo (acquired later by Semtech) company. It uses the spread spectrum technique modified from Chirp Spread Spectrum (CSS) modulation technology. LoRa is a part of LPWAN and a subpart of the Wireless Wide Area Network (WWAN). While other established wireless systems are using Frequency Shift Keying (FSK) modulation (due to its low power characteristic), CSS modulation preserves the same low power characteristics and adds a higher range of possible communication. LoRa represents a wireless communication system focused on the transfer of small size data with a low data rate (up to 50 kbps) for long-range. Typically, it achieves a range of 20 km (and even more if in Line-of-Sight – LOS) with preserving low power consumption (units of μA). Employing of Adaptable Bit Rates (ADR) extends durability (up to 10 years, depending on frequency) of the most suitable applications of the LoRa system, sensors with battery sources while used spread spectrum technique enables data transfer on a very long range.

In brief, the LoRa system can be characterized by the following:

- Robustness – high level of interference resistance
- Long Range – with preserving low power consumption
- Multipath/fading resistance – suitable for urban/suburban use
- Network Capacity – possible multiple transfers with different data rates
- Doppler resistance – resistant to doppler effect/shift

The LoRa is defined as a PHY layer developed by a Semtech company based on CSS modulation. The MAC layer is defined by the Long Range Wide Area Network (LoRaWAN) protocol with a focus on the system architecture [1], [8].

3.1.1 Complementarity with other wireless standards

There have been proposed different systems to realize wireless communication links. Still, until the introduction of the LoRa system, there was a gap between the short-range systems with a low to a high rate (Wi-Fi, Bluetooth, ZigBee) and long-range systems with a high rate (Cellular - GSM, LTE, 5G). The missing group was a long-range system with a low rate represented by LoRaWAN.

- Wi-Fi - cover mainly short and medium ranges with a high rate without the need for low battery consumption, used for internet browsing, video watching
- LoRa/LoRaWAN – cover medium and high range with a low data rate and low consumption of battery, used for sensors of every kind where is no need of high rate continual transfers of data [8]

3.2 Frequency bands, channels, and architecture

3.2.1 Frequency bands and channels

The RF bands for LoRa, are defined according to country and region. Reserved space is mostly in the Ultra High Frequency (UHF, 300MHz - 3GHz) band. These RF bands are around frequencies 169 MHz, 433 MHz, 868 MHz, 915 MHz, and newly introduced 2,4 GHz band. While European countries use frequency band 867-869 MHz (868 MHz) or 433 MHz, North America (USA, Canada) utilizes 902-928 MHz (915 MHz). For Asian countries, an RF band around 430 MHz was reserved. Despite this, China uses a band around 490 MHz, while Korea, together with Japan, operates mainly in the 923 MHz band [1], [8].

Frequency	169 MHz	433(430) MHz	868 MHz	915 MHz	923 MHz	2.4 GHz
Country	-	EU, Asia	EU	USA, Canada	Korea, Japan	All countries

Table 3-1 LoRa frequencies according to country/region

For Europe, there are defined 10 RF channels, while 8 of them are channels with multi-data rates varying between 0.25 kbps to 5.5 kbps. One channel is a high rate with speed around 11kbps, and the last one is the FSK channel, with a data rate of up to 50 kbps. Restrictions forbid to use maximum power output more than +14 dBm (+23 dBm in G3 band) [1].

In the USA or Canada, there are 64 uplinks 125 kHz channels, 8 uplink, and 8 downlink 500 kHz channels. The maximum power output is limited to +30 dBm.

3.2.2 Network architecture

The LoRa can use different topology than other typical wireless systems. LoRa adopted a star architecture for achieving low power consumption and long-range communication. It consists of many end-nodes, several gateways, and network servers (also application server). The LoRa end-nodes are not tied up to the specific gateway, but they broadcast packets of data, and more of gateways are able to receive them and forward to a network server (cloud) using backhaul (LTE, 802.11 – Wi-Fi, 802.3 – Ethernet). The network server performs most of the work, such as security acts, acknowledgment, redundancy reduction, or management of the network [1].

3.3 PHY layer

The LoRa is a system with high resistance against interferences and fadings occurring at multipath propagation. Nevertheless, it has small initial capital and operation costs, it enables long-range and Doppler resistant, small-size data transfer. LoRa is also “equipped” with the ability to range and localization. The block diagram of LoRa PHY is shown in the next figure (3-1).

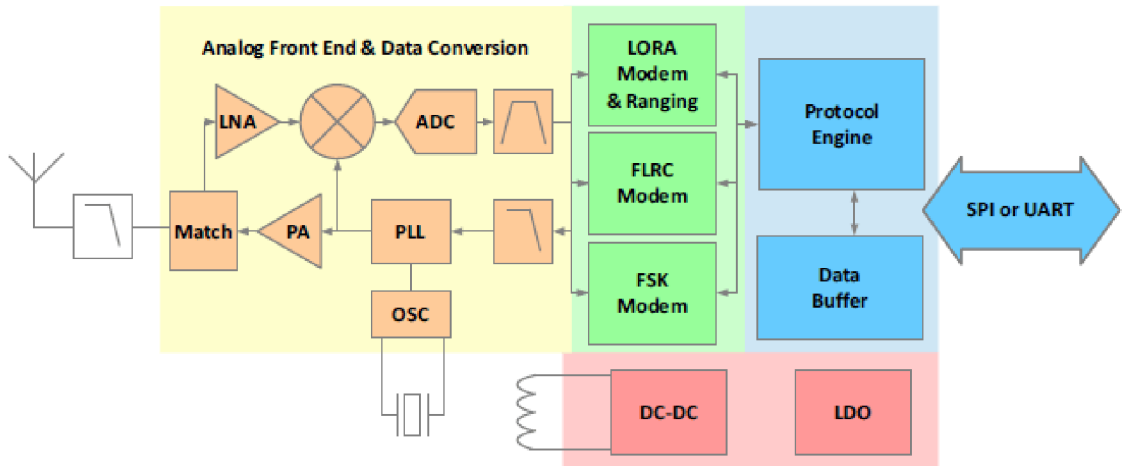

Figure 3-1 LoRa PHY layer block diagram, (taken from [9])

3.3.1 PHY parameters

The PHY layer of LoRa is characterized by the following parameters (Carrier Frequency – CF introduced in the previous part), Coding Rate (CR), Spreading Factor (SF), Bandwidth (BW) and the modulation. These parameters relate to each other, and their combination has a direct influence on the performance of the LoRa communication link (sensitivity, robustness) [3], [10].

Bandwidth (BW)

The BW of LoRa can be selected in the range from 7.8 kHz up to 500 kHz, and typical BW options for the LoRa system are 125, 250, and 500 kHz (corresponds to LoRa options BW125, BW250, and BW500). In our case of 2,4 GHz module 200, 400, 800, and 1600 kHz (corresponds to LoRa options BW200, BW400, BW800, and BW 1600). While using low BW, we achieve higher sensitivity of the system, due to low BW data rate is lower, and we need to transfer data longer. On the other hand, we can achieve higher data rates with higher BW at the cost of sensitivity due to additional noise in the channel. BW relates to the chirp speed that is equal to bandwidth (for example, if we have 500 kHz BW, it equals to 500kpcs chip rate).

With BW, we also define the symbol period (T_s) given by the equation:

$$T_s = \frac{2^{SF}}{BW}, \quad (3.1)$$

where BW is the bandwidth of LoRa, and SF is the value of spreading factor (SF).

Spreading Factor (SF)

The ratio chip rate (R_C) and the symbol rate (R_S) can be formulated as follows:

$$R_C = 2^{SF} * R_S, \quad (3.2)$$

The SF in LoRa varies from 5 to 12. The higher is the SF, the sensitivity of the receiver is higher, and the required Signal-to-Noise Ratio (SNR) is lower (in case of SF12, the required SNR is -20 dB). With the higher SF, more time is needed to send data but with a better signal range. Obviously, when lower SF value is used, then the time for transmission is shorter, and the required SNR is higher (for SF 5, the required SNR is -7,5 dB). The high data rate is achieved with small SF at the expense of lower signal range and problems with signal detection.

Coderate (CR)

The CR defines the level of Forward Error Correction (FEC), used to control error protection of LoRa transmission. The CR can be 4/5, 4/6, 4/7, and 4/8. With higher CR, higher safety of transmission is guaranteed with longer data transmission and lower SNR and vice versa. Modules can communicate together independently on the value of CR (must have the same frequency, SF, BW) since 4/8 CR always codes the header of the frame.

The raw data rate (R_b) is defined as:

$$R_b = SF / T_S \quad (3.3)$$

The data rate relates to every parameter, so if we increase the BW, then it affects the value of R_b in a defined ratio by equation (3.4). R_b can be evaluated using the following formula:

$$R_b = SF * \frac{BW}{2^{SF}} * CR \quad (3.4)$$

In the next table, all the possible values of LoRa parameters are displayed.

SF (-)	5 (2.4GHz)	6 (2.4GHz)	7 (all)	8 (all)	9 (all)	10 (all)	11 (all)	12 (all)
BW (kHz)	125 (sub- GHz)	250 (sub- GHz)	500 (sub- GHz)	200 (2.4GHz)	400 (2.4GHz)	800 (2.4GHz)	1600 (2.4GHz)	-
CR (-)	4/5	4/6	4/7	4/8	-	-	-	-

Table 3-2 Possible values of LoRa parameters

Modulation

For a LoRa, it is possible to use the LoRa modulation, Fast Long Range Communication (FLRC), and (Gaussian) Frequency-shift keying ((G)FSK) modulation. The basic LoRa

modulation uses a modified form of spread spectrum modulation with linear frequency modulated pulses. Originally, LoRa modulation is based on chirp modulation. This enables to demodulate signals 20 dB below the noise and, in combination with the Forward Error Correction (FEC), makes it more efficient compared to the FSK system. FLRC modulation is not considered for the measurement and, therefore, is not introduced. FSK is a frequency modulation based on a change of carrier wave frequency. In the case of LoRa modules, GFSK is used with optional values ($BW_{\text{LoRa}} = 2.4 \text{ MHz}$, $BW_{\text{LoRa}} = 1.2 \text{ MHz}$, $BW_{\text{LoRa}} = 0.3 \text{ MHz}$) [11].

3.3.2 LoRa Frame

The LoRa defines 2 types of frames: explicit (variable-length) and implicit (fixed-length). While the implicit format is without header, then the explicit frame contains a short header with information about the coding and the number of bytes for transferring.

The LoRa packet typically starts with preamble with a default length of 12bits, which is used for synchronization of the receiver with the signal. The length is variable from 12.25 to 65539.25 symbols. The receiver (RX) and transmitter (TX) preamble setting should be the same before the start of transmission. If the setup of the preamble is unknown, the RX should setup a preamble to the highest possible value (65539.25).

Explicit frame

After the preamble, the frame continues with a header consisting of information about the length of the payload in bytes, FRC code rate, and *cyclic redundancy check* (CRC) of the header. After the header, data itself is going on with length variable from 1 to 255 bytes, and in the end, there is an optional CRC part with a length of 16 bits.

Implicit frame

It is possible to realize a LoRa transmission without a header. After the preamble, the frame continues with payload with the same allowed length as in explicit mode (1-255 bytes), and also, there is a possibility to add CRC part again (16 bits) [12].

3.4 LoRaWAN

The LoRaWAN protocol defines network architecture and has the highest impact on capacity, power consumption, security, and Quality of Service (QoS).

3.4.1 LoRaWAN end-device classes

The LoRa end-devices are divided into three main groups according to the purpose of their operation. For different tasks/applications, different requirements need to be fulfilled.

Class A – low power, end-devices

All the LoRaWAN devices must support class A. The LoRa communication must be initiated by the end-device, and it is asynchronous. Together with the start of the communication, there are two short downlink windows following, that allow bi-directional communication. After the transfer of data, the device goes to “sleep mode” (lower power consumption) and wakes up from this state again only if it is needed. It cannot be woke up by the network server, and it must wait till another defined scheduled link defined by end-device come by.

Class B – end-devices with downlink latency

Compared to a Class A, where messages are received in random windows, Class B introduces sending some extra windows in the scheduled times. The end-device needs to know the exact time when it should expect messages to open the receiving window. It is solved by a time-synchronized beacon sent by the gateway to the end-device.

Class C – lowest latency end-devices

Devices of Class C are continuously in a receiver mode that reduces latency, except the time when an end-device is transmitting. Unlike Class A, the network server can keep the communication at any time, thereupon the consumption of the device is rising (up to 50 mW) [1], [8] .

In this thesis, we will work only with the class A.

4. IEEE 802.11 (WLAN)

Nowadays, a standard IEEE 802.11, part of the WLAN family, is probably the most comprehensive wireless communication system in the world. You can find Wi-Fi, a user brand of this standard, almost everywhere. It was introduced in 1997 as a part of the 11th workgroup (WG). To use an 802.11, non-license 2.4 GHz ISM (Industrial, Scientific and Medical) band was reserved. The standard defines the first 2 layers of ISO model: The Physical (PHY) layer specifications and the Media Access Control (MAC). After 2 years, in 1999, there were published two enhanced standards of the PHY called 802.11a and 802.11b with the band 5GHz and 2.4 GHz, respectively. The defined data rate of the first wireless standards was 11 Mbps (in case of 802.11b) or 54 Mbps (in case of 802.11a). Expression “802.11x” is used to mark different modifications and plugins of this standard. In this work, only IEEE 802.11b/g/n standards are considered. The PHY layer is briefly described in the following subsections. [13]- [14] .

4.1.1 802.11b

Standard IEEE 802.11b was developed in 1999 alongside 802.11a but worked in 2.4 GHz ISM band. With a theoretical data rate, 11 Mbps (practically 5 Mbps) was achieved higher bandwidth than legacy version due to the use of Complementary Code Keying (CKK) in cooperation with Direct Sequence Spread Spectrum (DSSS) modulation but still lower data rate than 11.a version. Despite this fact, 802.11b is more known standard due to cheaper technology and higher range (absorption in 2.4 GHz band is much lower than in 5 GHz band). As the modulations, DQPSK and QPSK are used. The number of channels is between 11 to 14, depending on the country and region (Europe - EU 13, USA 11, Japan 14). The channel width is 20 MHz. Due to operating in different bands, 11a and 11b standards are not compatible. While 11.b was widely spread in almost every sector, 11.a found limited application only in business and industrial networks [15], [16] , [17].

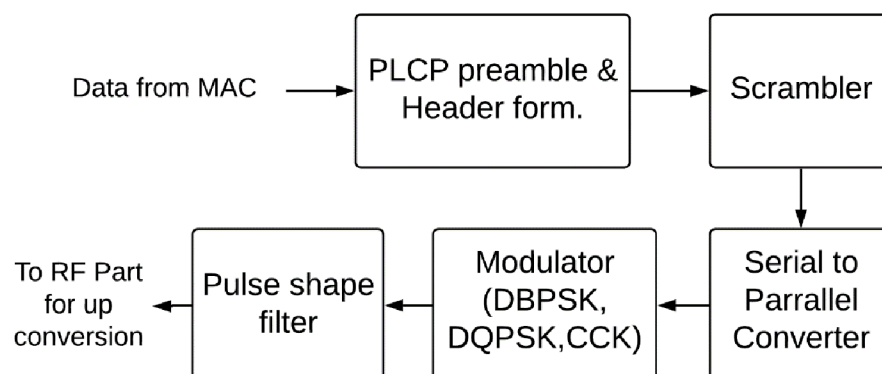

Figure 4-1 802.11b PHY layer block diagram, (based on [18])

Release date	Frequency	Modulation	Data rate
October 1999	2.4 GHz	DSSS (CCK)	Up to 11 Mbps

Table 4-1 Parameters of 802.11b standard

4.1.2 802.11n

Another improvement of previous standards is introduced with a focus on improving the throughput of a system using Multiple Input Multiple Output (MIMO) technology. However, this solution is much more expensive than the previous classic standards. Another novelty was work in both bands, 2,4 GHz and 5 GHz simultaneously. It is possible to use modulations BPSK, QPSK, 16QAM, and 64QAM. Compared to the previous standard, the data rate went up significantly up to 600 Mbps (only theoretically, practically max. around 300 Mbps) with optional channel width (20/40 MHz). The modulation CCK and DSSS are used due to compatibility with previous standards and OFDM to improve data rate. Also, 3 modes were introduced:

Legacy: 20/40 MHz signal, designed for the 11b/g/n

Mixed: 2,4/5 GHz, compatibility with every standard 11a/b/g/n

Greenfield: mode without compatibility, designed only for the 802.11n to achieve the maximum data rate

Higher numbers of antennas raised a problem with the empowering of these elements. As a solution, the power saving mode was introduced [16], [17], [19].

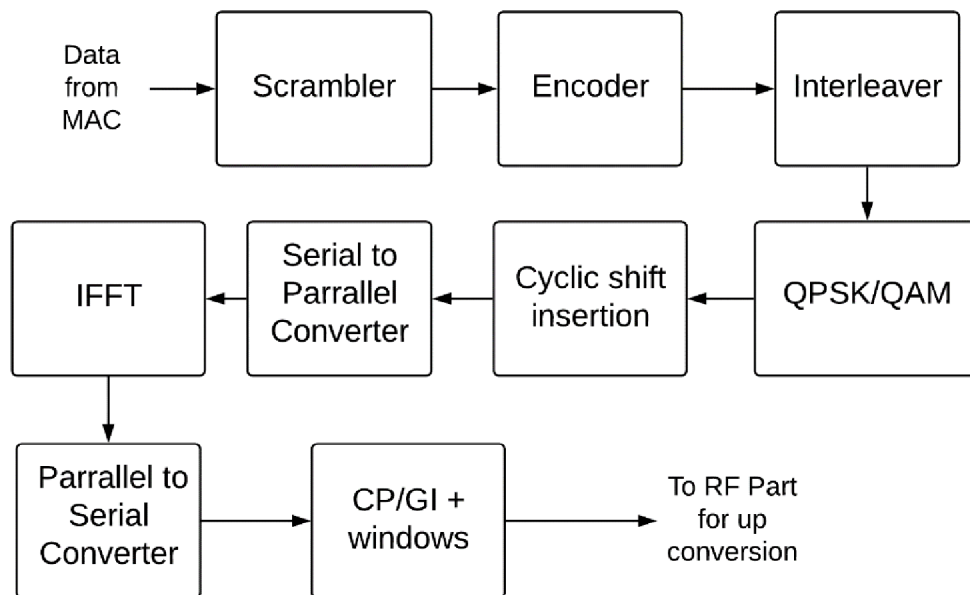

Figure 4-2 802.11n PHY layer block diagram, (based on [20])

Release date	Frequency	Modulation	Data rate
September 2009	2.4/5 GHz	OFDM	Up to 600 Mbps

Table 4-2 Parameters of 802.11n standard

4.2 Physical layer

The physical layer (PHY) is a physical interface between stations connected to the network. 802.11 standard defines wireless networks, so the PHY is defined as a wireless layer. In 1997 in the original version of 802.11 there were standardized 3 PHY layers:

- Frequency-Hopping Spread-Spectrum (FHSS) radio PHY
- Direct-Sequence Spread-Spectrum (DSSS) radio PHY
- Infrared light (IR) PHY

After the revision in 1999 another 2 layers were added:

- Orthogonal Frequency Division Multiplexing (OFDM) PHY
- High-Rate Direct Sequence (Spread Spectrum-HR/DS or HR-DSSS) PHY

In all standards of IEEE 802.11 the PHY layer is divided into 2 sublayers:

- Physical Layer Convergence Procedure (PLCP)
- Physical Medium Dependent (PMD)

4.2.1 Spread Spectrum (SS)

The technology of the spread spectrum (SS) is used to achieve high-speed data transfers in the ISM band. While the traditional radio technologies are focused on the insert as the highest number of signals into narrowband (bandwidth used to transfer is almost equal to the bandwidth needed for the transfer – narrowband system), the SS uses mathematic functions to disperse the power of signal into full frequency block and to use more bandwidth than is needed for the signal. The signal is spread in the TX by a unique code that must also be known by the receiver to decode signals properly [16], [21].

4.2.2 Frequency Hopping Spread Spectrum (FHSS)

The frequency hopping systems use classic basic modulation techniques, but carrier frequency is changed in different intervals, and transmission from the TX is “hopping” from one carrier frequency to another. The carrier frequency hops in a pseudo-random sequence that is defined by a code and on every frequency transmit short bundle of data. The RX must also know this code, and both RX and TX must be synchronized. We can divide Frequency Hopping (FS) techniques into 2 groups:

- Fast Frequency Hopping (FFH)
- Slow Frequency Hopping (SFH)

The FHSS is defined in 2 modes: 1 Mbps and 2 Mbps. Also, different types of modulations are used (possible combination with hoping sequence) from BPSK and QPSK to more types of FSK. The number of channels depends on the region. Also, many countries in the same region got a different number of channels from 79 available channels with width 1 MHz [16], [21].

4.2.3 Direct Sequence Spread Spectrum (DSSS)

While in the FHSS, the spreading depends on frequency hopping, in the DSSS the modulation rate is intentionally increased to spread spectrum of a signal using a combination of original data with higher rate chip sequence (binary sequence) with a length of 11b, and in 802.11 standards it is called Barker's code. An addition regularly makes this a combination with XOR (Exclusive OR) gate. The communication is in progress at only one channel at the time, and the device chooses it. After this operation, we receive a new sequence with a chip rate that is used to modulate the carrier. This operation causes redundancy in the communication channel and raises the interference resistance and substantiality of the system. Especially, a redundancy is helpful for safety reasons due to redundant data look like noise to the attacker. On the receiver part, there is an inversed operation where the received sequence is decoded using chip sequence and demodulated with a focus on restoring primary data from the transmitter. The DSSS-based systems can use BPSK or QPSK modulations.

As in the FHSS, also the DSSS is divided into 2 modes: 1 Mbps and 2 Mbps. Several channels are different depending on a country and region (up to 14 channels). The bit rate depends on a used modulation (BPSK – 1 Mbps, QPSK – 2 Mbps), while a symbol and a chip rate are fixed (1 Mbps / 11Mbps). The bandwidth of the channel is strictly given as 22 MHz. Almost all channels are overlapping each other except channels 1, 6, and 11. After releasing 802.11b, the modification of DSSS was used, High Rate - Direct Sequence Spread Spectrum (HR-DSSS), with a higher bit rate up to 11 Mbps [2], [16].

Complementary Code Keying (CCK)

In the case of an 802.11b also a modulation CCK was used alongside the DSSS to improve the data rate of this standard. CCK was introduced in 1999 as the addition of the Barker code in a wireless network to achieve higher data rates at the cost of signal range due to narrowband interference [22].

4.2.4 Orthogonal Frequency Division Multiplexing (OFDM)

Orthogonal Frequency Division Multiplexing (OFDM) is a form of signal or modulation that provides some significant advantages. It is characteristic for its high speed and wideband transfer of data and high resistivity to the interference [6], [16], [21].

The OFDM signal consists of more narrow-modulated carriers. The receiver operates like a group of demodulators converting every carrier to direct current, and the signal is integrated during the symbol period for the data regeneration. The OFDM is based on the conversion of high-speed serial data flow into several slower parallel data flows, and symbols are much more distant (in time). In the case of lost or damaged data, there is a high possibility of repairing/reconstructing data thanks to error coding techniques that are transferred in another part of the signal.

The essential advantages of the OFDM are spectral efficiency, interference resistance, high level of inter-symbol interferences (ISI) resistance, and the narrowband effects resistance. On the other hand, a high peak to average power ratio (PAPR) or sensitivity to carrier offset is one of the disadvantages. OFDM used in 802.11a/g achieved maximum rate up to 54 Mbps, while modified version of OFDM like High Throughput OFDM (HT-OFDM, up to 600 Mbps, 802.11n) or Very High Throughput (VHT-OFDM, up to 3466 Mbps, actual standard 802.11ac) achieves even higher rates. Modulations used among OFDM are BPSK, QPSK, 16-QAM, or 64-QAM.

4.3 Media Access Control (MAC) Layer

The data-link layer is responsible for the transport and coding of the information, while its sublayer MAC defines the rules on how to access resources needed by data transfer. The PHY layer is responsible for transfer details. Sublayer is also using the PHY layer for broadcast, receiving, and transfer of 802.11 packets [16], [21].

4.3.1 Attributes of MAC

- **CRC (Cyclic redundancy check)** – used to detect errors during the transfer of data, every packet obtained with CRC, and sent alongside data to quickly determine if the packet was damaged or changed during transmission.
- **Fragmentation** – dividing of a large packet into a group of smaller packets, established for reduction of channel occupation and reliability improvement. Smaller packets are transferred one after the other to reduce the chance of packet damaging. Chances of packet damage rise proportionally to the length (size) of a packet. In the case of the defect packet, it is much easier to send another small packet than the original one.
- **Collision avoidance** – in the case that 2 stations are trying to broadcast at the same time, Carrier Sense Multiple Access/Collision Avoidance (CSMA/CA) is implemented, control packets Request to send/Clear to send (RTC/CTS) are used for this purpose.
- **Acknowledgment** – every packet confirmed after correct transfer without damage or errors, positive acknowledgment.

4.4 RF bands and channels

The IEEE 802.11 implements wireless local area networks in the 900MHz, 2.4, 3.6, 5, and 60 GHz frequency bands. In this thesis, only the 2.4 GHz ISM is considered. The bands are subdivided into channels. A center frequency and bandwidth characterize channels. While center frequency is moving with a distance of 5 MHz, bandwidth is the same all the time, 22 MHz. Due to this fact, there are only 3 non-overlapping channels. The figure (4-3) displays the 2.4 GHz ISM band.

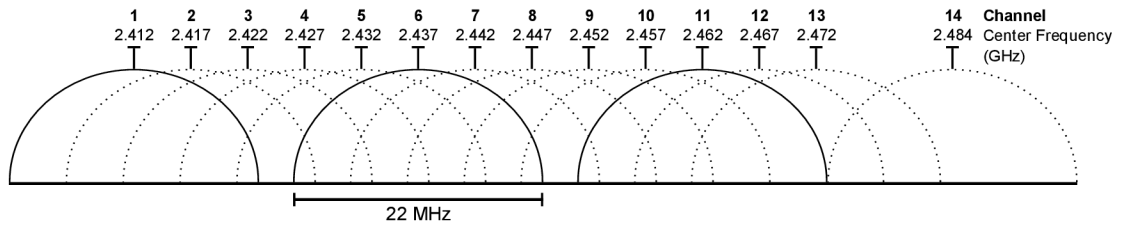

Figure 4-3 802.11 channels at 2.4 GHz, (taken from [24])

Band is divided into 14 channels (depending on country and region, mainly 13, in Japan 14) with 5 MHz steps between each other [2], [23].

5. LORA AND WLAN IN THE 2.4 GHZ ISM BAND- COEXISTENCE SCENARIOS

As it was mentioned previously, the LoRa system was primarily developed for sub-1GHz ISM bands. The Semtech company has already released the SX 1280 transmitter/receiver module [9] to realize a communication link in the 2.4 GHz ISM band. Nevertheless, WLAN and related IEEE 802.11 technologies can utilize RF bands from 900 MHz to 60 GHz, recently, the 2.4 and 5 GHz RF band is one of the most used to realize an IEEE 802.11-based wireless link. The presence of LoRa in the 2.4GHz RF band can cause unwanted interference for other systems and vice versa.

In this thesis, only the 2.4 GHz ISM band is considered. Next, the LoRa and Wi-Fi will be considered as the interfered and interference signal, respectively.

5.1 Coexistence scenarios

5.1.1 Coexistence

To define coexistence as a term, we need to come out of term coexistence defined by workgroup IEEE P802, and especially subgroups like P802.16.2 or P802.15.2 [25]. These groups are responsible for definitions and recommendations on the coexistence of WiMAX or Bluetooth, respectively. However, these definitions are applicable to every wireless system/network. The first one was presented by Steve Shellhammer [26]: “Multiple wireless devices are said to “coexist” if they can be collocated without significantly impacting the performance of any of these devices.” David Cypher presented the second one [27]: “The ability of one system to perform a task in a given (shared) environment where other systems may or may not be using the same set of rules.” Interesting is also the definition by IBM company [28]: “Coexistence occurs when two or more systems at different software levels share resources. The resources could be shared at the same time by different systems in a multisystem configuration, or they could be shared over a period of time by the same system in a single-system configuration”.

After the introduction of the 2.4 GHz LoRa module working in the ISM 2.4 GHz band, it is evident that there is a possibility of interference with another wireless system operating in this band. According to [3], in general, there are three common strategies for coexistence/avoiding Wi-Fi for the LoRa system: Frequency separation, Temporal separation, and Spatial separation. While spatial (avoiding the same location) and temporal (avoiding communication at the same time) is not essential for our measurements, frequency separation (avoiding communication on the same frequency) will be considered in this thesis.

Depending on how wireless systems can coexist, we define three types of interference scenarios, the Co-Channel Coexistence Scenario (CCCS), the Adjacent Channel Coexistence scenario (ACCS), or In-Band Coexistence Scenario (INCS) and Out-Band Coexistence Scenario (ONCS).

5.1.2 Coexistence scenarios

CCCS is occurring in the case when two systems are provided on the same carrier frequency. In our case, both LoRa and Wi-Fi have the same working frequency.

On the other hand, ACCS or INCS is caused by the power of transmitter from an adjacent channel, so systems are not working on the same frequency but in the same frequency band and interfering with each other. ACCS or INCS are defined mainly by a delta of frequency or frequency offset (Δf) from the center frequency. Both scenarios are shown in a figure (5-1)

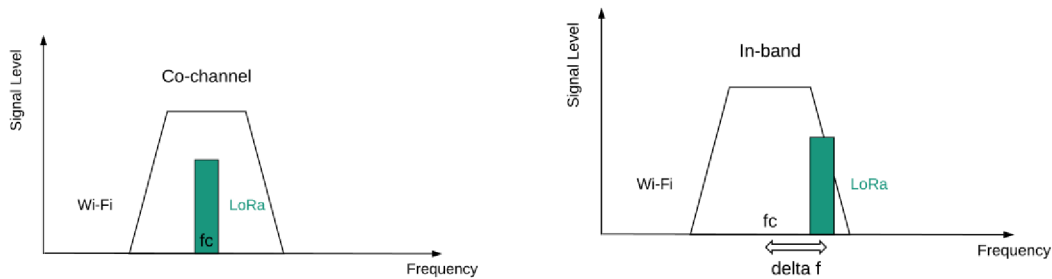

Figure 5-1 Co-channel and In-band coexistence scenarios

ONCS, as the name says, describes the scenario between two systems that are separated and have non-overlapping RF bands. Together with ONCS, we need to define also a guard band (GB) that describes frequency offset or distance between RF spectra of two signals. This scenario is shown in the figure (5-2).

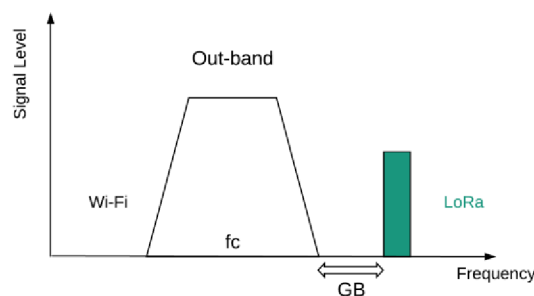

Figure 5-2 Out-band coexistence scenario

6. MEASUREMENT SETUP AND METHODOLOGY

6.1 Measurement Testbed

The measurement setup to monitor and analyze coexistence between LoRa and Wi-Fi in laboratory conditions was realized at the Department of Radio Electronics (DREL) in the laboratory of Mobile Communications. A block diagram of the realized workplace is shown in Fig. (6-1).

For this purpose, two primary devices were chosen, signal a spectral analyzer Rohde & Schwarz FSQ 8 and arbitrary waveform and vector signal generator Rohde & Schwarz SMU200A. As a part of the measurement setup, there was also a portable computer (PC) with application *WiMOD LR Studio* for control and management of LoRa modules SK-iM282A Long Range radio starter kit [29] using USB cables without need of additional power supply (batteries). The proposed setup is not automatized due to the inability to modify *WiMOD LR Studio* and incapability to communicate with LoRa modules in another way.

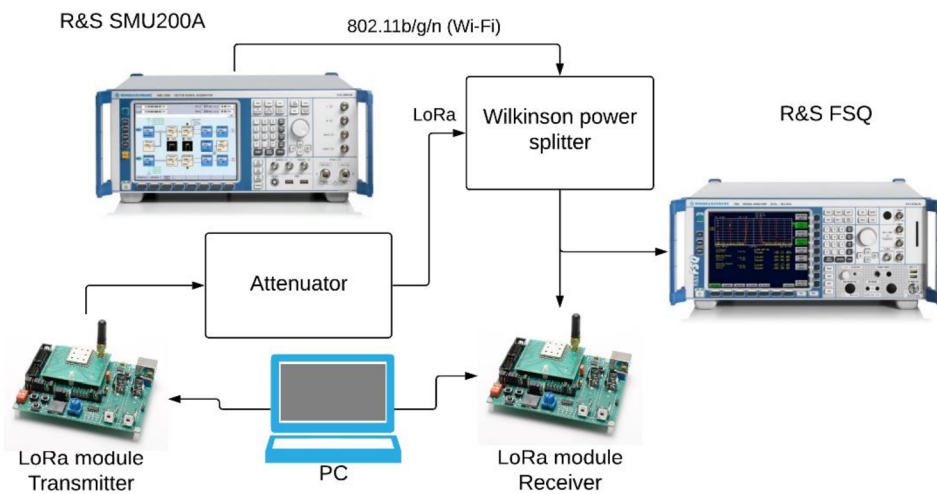

Figure 6-1 Block schematic of a measurement setup

LoRa modules SK-iM282A are long-range modules produced by Semtech company designed to operate in the 2.4 GHz band. In the case of configuration with the highest resistance against noises (SF 12, BW200), receiver sensitivity is from -120 dBm up to -130 dBm with power output up to +12 dBm.

Signal analyzer R&S FSQ 8 is used to display LoRa and Wi-Fi RF spectra. It can measure RF signals from 20 Hz up to 8 GHz. It has the possibility to measure power

levels (in dBm) in the considered RF channel. This device is essential to measure parameter Carrier-to-Interference Ratio (C/I), which will be introduced later [30].

The R&S SMU200A is a two-channel arbitrary RF signal generator. The output frequency of generated signals is in the range from 100 kHz up to 6 GHz in channel A, and for channel B, it is from 100 kHz up to 3 GHz. Both LoRa and Wi-Fi are provided in the ISM 2.4 GHz band, so both channels fit this measurement, and channel B was chosen [31]. The Wi-Fi signal, according to considered IEEE 802.11 technology, is generated natively by this device, so no extra waveforms were needed from the manufacturer.

The LoRa modules, the FSQ 8 signal analyzer, and the R&S SMU200A generator are connected with RP-SMA cables. The LoRa and Wi-Fi RF signals are combined in using of Wilkinson power splitter/divider. Due to HW and SW power limitations of the LoRa module (-18dBm to 8 dBm) and vector signal generator (up to 5dBm), an attenuator was used to attenuate the level of LoRa signal.

The realized measurement workplace is depicted in Fig. (6-2).

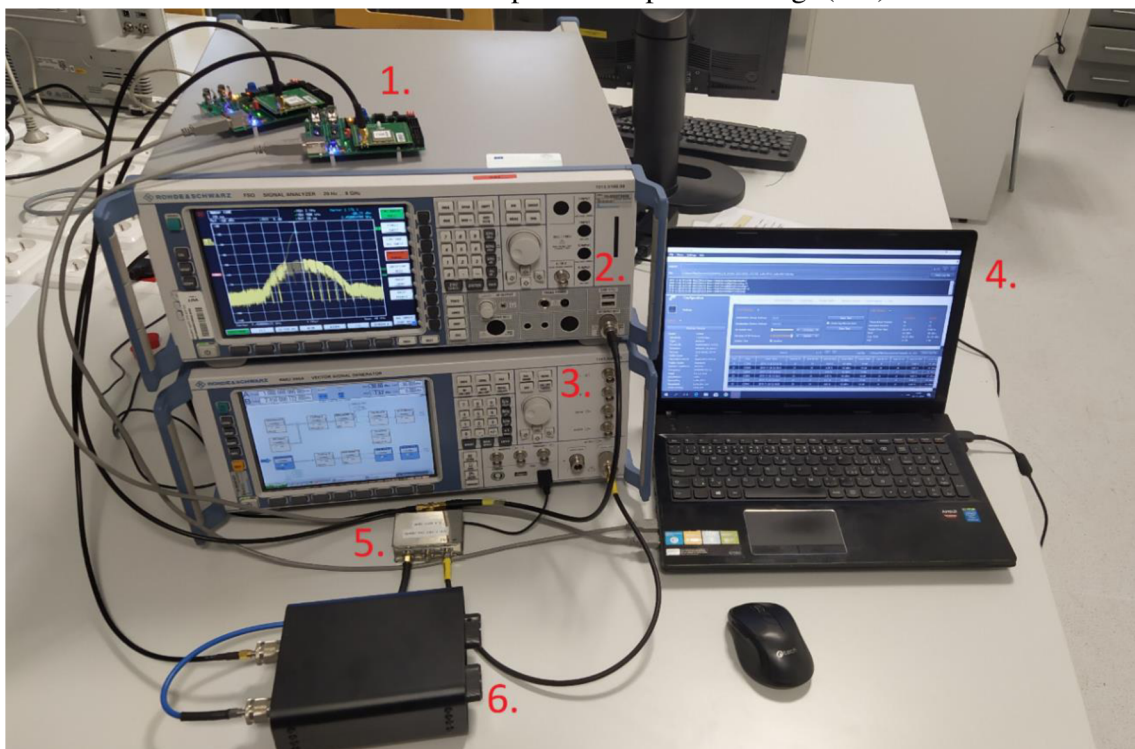

Figure 6-2 Measurement testbed: 1. LoRa modules SK-iM282-A, 2. Signal Analyzer R&S FSQ 8, 3. Signal Generator R&S SMU200A, 4. PC, 5. Wilkinson power splitter, 6. Attenuator

6.1.1 WiMOD LR Studio

Program *WiMOD LR Studio* is a Microsoft Windows application created by Semtech to ensure user-friendly planning and control of the LoRa communication. It links the application with a Graphical User Interface (GUI), allows the user to set different parameters of the LoRa system, and monitor the LoRa communication link. The communication between *WiMOD LR Studio* and connected LoRa modules works on the principle of exchanging Health Control Interface (HCI) messages. For this, a serial interface between the host controller (microcontroller) and the LoRa radio module is used [32].

To establish communication between LoRa modules, firstly, we need to download the latest drivers of *WiMOD LR Studio* to the PC. The default set-up of LoRa modules must be set before connecting via USB cables to the PC. After the connection of modules to the PC, we need to open *WiMOD_LR_Studio.exe*, and modules become connected.

Features of the *WiMOD LR Studio* are presented on several pages with two directions of navigation bars, vertical and horizontal. The vertical bar on the left side of the application offers the main sections like ***Radio Services***, ***Configuration***, and ***Extras***. The horizontal bar provides additional features as a part of subpages depending on the chosen main section. The connection of modules is made automatically with several information (port, type, frequency, SF, CR, or power level) showed under the vertical navigation bar with the main section. In the case of the not recognized module, also the feature “*Discover Devices*” is implemented, too. Studio also implements the connection of several devices that can be controlled by one PC. We can also find the so-called “Event Box” window on the left side of the application providing information about events or results of commands. “Search” box allows us to find exact command or result while “Log File/Events/Data” (depends on used feature) allows recording all status lines and convert them into the text file.

In the next figure (6-3), essential parts of *WiMOD LR Studio* are displayed.

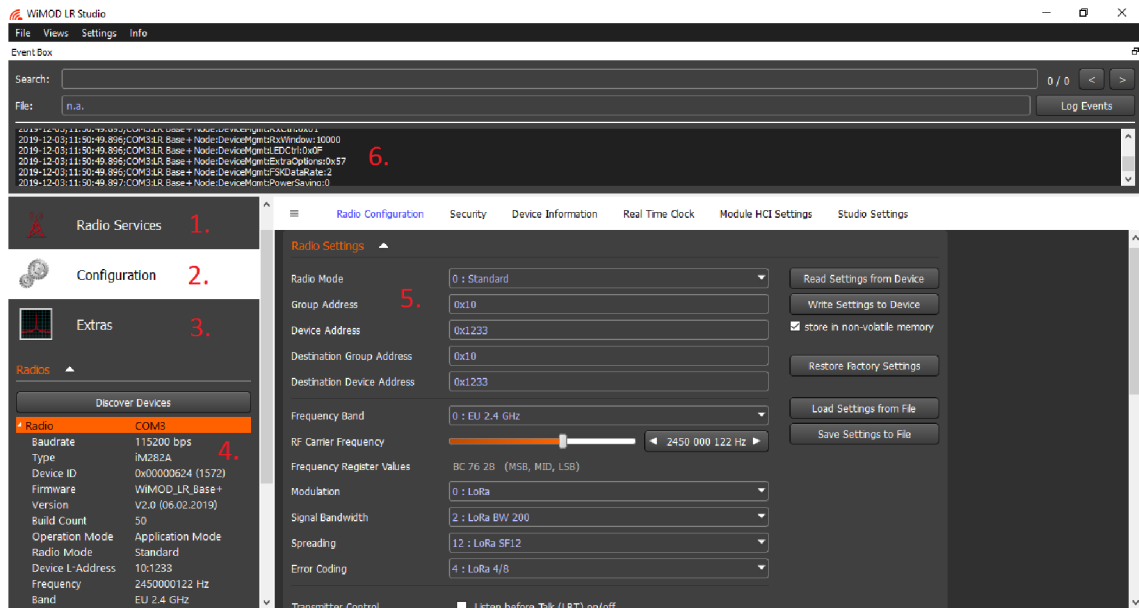

Figure 6-3 WiMOD LR Studio: 1. “Radio services” bar (used for test), 2. ”Configuration” bar, 3. “Extras” bar, 4. Information about connected modules, 5. “Radio configuration” (complete configuration of LoRa module), 6. “Event box.”

Only a few important features are introduced. The first of them is “Radio Configuration” as a part of the main section “Configuration.” This feature allows us the setup of the LoRa module starting with the module and group address, radio mode (Standard or Sniffer), frequency band (in this case limited to EU 2.4 GHz only), or carrier frequency (2.402 – 2.479 GHz). The next parameters are modulation (primary LoRa modulation, FLRC, FSK), bandwidth (200-1600 kHz/BW200-BW1600), Spreading Factor (SF5-SF12), Error Coding (Code Rate, from 4/5 to 4/8) and power level (-18 dBm up to 8 dBm). Another part allows us to manage receiver and transmitter (RX/TX) control, LEDs control, Real-time clock (RTC), or different options not important for the purpose of this thesis. *WiMOD LR Studio* allows load sets from the file or saves setting it to the file with the option of factory setting restore. Confirmation of selected parameters is done by “Write settings to device” while “Read setting from device” gives us information about the actual module set.

The other feature is the “Radio Link Test” that we can find in the main section, “Radio Services.” It allows us to verify the radio link quality between two LoRa modules. It offers to set up destination group/device address, size of the RF packet (15 up to 255 Bytes), number of packets that are supposed to be sent (100 up to 50000) with choice of infinite test. The possibility of creating a log file is implemented. On the right side of the page, a window “Link Status” is visible, providing information about transmitted and received packets, Packet Error Ratio (PER), Received Signal Strength Indicator (RSSI), average RSSI and Signal-to-Noise Ratio (SNR). Below this window is implemented the graphical representation of RSSI actual value (local and peer device). In this test, one device is local, and the other is a peer device. Direction from a local to a peer device is called “downlink” while direction from a peer to a local device is called “uplink.” Under the graph is located window providing information about the connection between devices

with parameter information already mentioned before for every link attempt (PER, peer/local RSSI, peer/local SNR, uplink TX/RX, and downlink RX/TX). To successfully connect peer and local devices, the same parameters (frequency, BW, SF, CR) must be set in both modules.

6.2 Methodology

In this section, we define the parameters that were measured and used to analyze the Wi-Fi immunity of LoRa. Also, the process of measurement is introduced. The methodology used in this thesis is verified was used before [33].

6.2.1 Measured parameters

In this work, the interfered (LoRa) and interfering (Wi-Fi) signals are marked as C and I , respectively. Together with the parameters C and I , parameter Protection Ratio (PR) is defined as a difference of C and I in the following equation (6.1):

$$PR = C - I \quad (6.1)$$

In our case, PR is defined as a ratio of C/I for a PER value of 10% and is expressed in dB.

Together with the introduction of the LoRa module for 2.4 GHz RF band, Semtech supports this module with its software (SW) WiMOD LR Studio that offers easy measurements of the PER and RSSI. Only these parameters will be measured and used to evaluate the LoRa communication link because the program supports only these [32].

PER defines the ratio of incorrectly received data packets and the total number of received packets. PER is expressed in %, and the requirement for reliable communication of LoRa systems, it is necessary to achieve PER under 10%. LoRa-based communication with PER above 10% is considered as not reliable [3].

RSSI is an estimated power level that the device is receiving from another device (in our case LoRa TX). This parameter is non-dimensional but often is presented in dBm.

6.2.2 Methodology of measurement

The measurements were performed for different system configurations (LoRa and Wi-Fi). The power output of LoRa is limited by an SW and HW specifications from the manufacturer (from -18 dBm up to 8 dBm). A high level of output power constant level of -18 dBm was chosen and will be attenuated using the attenuator to -85 dBm measured at the receiver. The power output of Wi-Fi is due to generator limitations also limited (maximum power up to 5 dBm) and will be varying concerning 10% PER limitation of

reliable communication. Time restrictions of LoRa Transmission restrictions in 2.4 GHz are not set, so preset transmission set-up defined by *WiMOD LR Studio* will be used.

To measure parameter PR , it is required to know the power levels of both signals. The value of I is a value measured by vector analyzer R&S FSP at the input of RX. The same case is valid for the C parameter that real value is not stated in the configuration menu in *WiMOD LR Studio*, but the value displayed by vector analyzer with I signal switched off at the input of TX. After we know both parameters, we can determine PR using formula (6.1).

Based on the first experiments [3], the parameters SF and BW, behind of signal power level, have the highest impact on the performance of LoRa interfered by Wi-Fi. The value of SF is optional from SF = 5 to SF = 12 (for sub-GHz SF = 7-12, while SF = 5, 6 are designed only for 2.4 GHz band). The value of BW is optional in the range from 200kHz to 1600 kHz. A combination of these values from both categories is important to propose the worst and best case. The other important parameter of LoRa, CR, will stay constant for the whole test period due to its immateriality or only neglectable influence on coexistence.

In the case of Wi-Fi, we consider three IEEE 802.11 technologies, namely IEEE 802.11b, IEEE 802.11g, and IEEE 802.11n. The first group is a set of 802.11b/g/n system parameters. There are considered different settings related to data throughput (in the case of 802.11b data rates 1 and 11 Mbps, in case of 802.11g data rates 1, 6, and 22 Mbps and finally in case of 802.11n data rates 54 Mbps). In the case of the IEEE 802.11n, only the SISO transmission mode is considered.

As mentioned before, measurements of coexistence are based on measuring of PR and frequency shift from center frequency and measuring in-band interference (Δf from center frequency) up to measuring out-band interference (parameter GB).

The performance of LoRa was evaluated in terms of PER and PR as the following measurement methodology was adopted [34]:

1. Set-up of wanted LoRa signal (C) power level – proposed value is -85 dBm using *WiMOD LR Studio* in the configuration menu, generated by LoRa modules as a constant value.
2. Initial set-up of interfering Wi-Fi signal (I) power level – the proposed difference at least -10 dB from the LoRa power level, in this case, -95 dBm at the input of the receiver, generated by R&S SMU200A
3. Set-up of wanted LoRa signal parameters (SF_{LoRa} , BW_{LoRa} , modulation), in *WiMOD LR Studio*, the configuration menu
4. Adjusting of interference Wi-Fi signal power level to achieve the required condition of 10% PER for LoRa reliable communication

5. The power level of the interfering Wi-Fi signal is measured by using R&S FSQ 8
6. Parameter PR is calculated from steps 1 and 5 using equation (6.1)
7. Repeating steps 1 to 5 varying the wanted LoRa signal frequencies from N to $N+1$ (N = LoRa starting frequency 2.437 GHz) with a step of 2 MHz.

Every step of measurement is considered for different configurations of LoRa and Wi-Fi system parameters. Measurements for all configurations should be done multiple times (3x) to validate received results.

7. EXPERIMENTAL MEASUREMENTS

Experimental measurements of two coexistence scenarios between LoRa and Wi-Fi were performed to verify theoretical expectations, the proposed measurement setup and to evaluate the worst and best case of LoRa and Wi-Fi parameter combination. In the case of selected coexistence scenarios (CCCS and IBCS), twelve combinations of LoRa parameters were considered. The considered parameters were BW_{LoRa} and SF_{LoRa} . Specific values of parameters are shown in the table (7-1). There were measured six different setups of the Wi-Fi system based on different technology (802.11b/g/n).

Parameters	LoRa level at RX input [dBm]	CR _{LoRa} [-]	BW _{LoRa} [kHz]	SF _{LoRa} [-]
Values	-85	4/8	200, 400, 1600	5, 7, 10, 12

Table 7-1 Co-channel and In-band scenario: system parameters of LoRa

Measurements were performed separately for Wi-Fi using 802.11b/g/n technology with a number of system parameters (DQPSK, DBPSK, BPSK, 8PSK, 64QAM). Measurements cover cases when narrowband (200 kHz) and wideband (1600 kHz) LoRa signals are interfered by Wi-Fi having a constant signal bandwidth of 20 MHz. Measurements were performed three times for each configuration.

As stated by the proposed methodology, the measured values were evaluated as a dependence of PR on frequency shift from center frequency and measuring in-band interference (Δf from center frequency). The results are graphically shown in the next subchapters for chosen Wi-Fi standards with limit values ($BW_{LoRa} = 200$ kHz, $BW_{LoRa} = 1600$ kHz, $SF_{LoRa} = 5$ and $SF_{LoRa} = 12$) supplemented with middle values ($SF_{LoRa} = 7$ and $SF_{LoRa} = 10$ and $BW_{LoRa} = 400$ kHz). Other parameter combinations were supposed to cover the area between these limit values. The proposed configurations based on different combinations of LoRa system parameters are shown in the table (7-2).

Combination of LoRa system parameters	
$SF_{LoRa} = 5, BW_{LoRa} = 200$ kHz	$SF_{LoRa} = 10, BW_{LoRa} = 200$ kHz
$SF_{LoRa} = 5, BW_{LoRa} = 400$ kHz	$SF_{LoRa} = 10, BW_{LoRa} = 400$ kHz
$SF_{LoRa} = 5, BW_{LoRa} = 1600$ kHz	$SF_{LoRa} = 10, BW_{LoRa} = 1600$ kHz
$SF_{LoRa} = 7, BW_{LoRa} = 200$ kHz	$SF_{LoRa} = 12, BW_{LoRa} = 200$ kHz
$SF_{LoRa} = 7, BW_{LoRa} = 400$ kHz	$SF_{LoRa} = 12, BW_{LoRa} = 400$ kHz
$SF_{LoRa} = 7, BW_{LoRa} = 1600$ kHz	$SF_{LoRa} = 12, BW_{LoRa} = 1600$ kHz

Table 7-2 Selected combinations of LoRa parameters for each measurement scenario

To improve the overview of the received values, graphical representations for chosen Wi-Fi signals are divided into three sub-graphs, according to BW_{LoRa} . Four characteristics, based on the value of SF_{LoRa} , are shown in each subchapter. Comments are placed together on one page while figures are following on another page.

7.1 LoRa vs. Wi-Fi (802.11b)

It is the first scenario, including a co-channel and in-band coexistence scenario that was explored in defined combinations of LoRa system parameters. The measurement is focused on the robustness of LoRa with selected parameters against the Wi-Fi signal. As an interfering signal, the IEEE 802.11b based signal using CCK with two different modulations was chosen. For all configurations, a payload with a long of 15 Byte was used. The basic configuration is shown in the table (7-3).

Parameter	Modulation technique	Modulation	Data rate
Type	CCK	DBPSK/DQPSK	1/11 Mbps

Table 7-3 System parameters of IEEE 802.11b used in the measurement

7.1.1 The IEEE 802.11b signal using of CCK (DBPSK) modulation

In this subchapter, results from the measurement of LoRa and Wi-Fi coexistence, in which Wi-Fi using 802.11b technology with system parameters defined in Table 7-3, are presented. The data rate of interfering the Wi-Fi signal achieves up to 1 Mbps. Static parameters were proposed with respect to the methodology. Transmission power level of LoRa measured at the receiver was = -85 dBm, $CR_{LoRa} = 4/8$, and $BW_{Wi-Fi} = 20$ MHz. Results are presented for the values of SF_{LoRa} (5, 7, 10, and 12).

Figure 7-1 describes the difference in dependency of parameter PR on the value of Δf at $BW_{LoRa} = 200$ kHz. In the case of the co-channel scenario, depending on the evaluated setup, the value of PR lies in the interval between -25 dB and -42 dB. With increasing frequency offset in the case of in-band scenario (increasing range of Wi-Fi signal from center frequency), parameter PR is decreasing in all parameter setups moderately until more than a half of RF spectre wide, specifically till the value of $\Delta f = 6$ MHz. From this point, the characteristic acquires precipitous trend, and the dependency of PR on the value of Δf has a significantly decreasing tendency. From this value of Δf , the interfering Wi-Fi signal has a negligible impact on LoRa. From the obtained curves, it is visible that the LoRa signal has the highest resistance against interferences at $SF_{LoRa} = 12$. This setup reach value of $PR_{10\%PER} = -42$ dB at center frequency ($\Delta f = 0$ MHz). It means that the interfering Wi-Fi signal has to be 42 dB stronger than the interfered LoRa signal with the preservation of reliable communication. On the other hand, the configuration of the LoRa signal with low SF_{LoRa} is less resistant to interference. To reach the value of $PR_{<10\%PER}$ at the center frequency for maintaining reliable communication, the value of PR is -25 dB. Setups with $SF_{LoRa} = 7$ and 10 are within the borders defined by LoRa system modes with the lowest and highest sensitivity.

Figure 7-2 demonstrates the difference in dependency of parameter PR on the value of Δf for $BW_{LoRa} = 400$ kHz. It is visible that with increasing frequency offset parameter

PR is decreasing in all parameter setups moderately. A critical point, as in the previous case, comes after more than half of spectre wide, around the value of $\Delta f = 6$ MHz. The results correspond with the previous case with similar characteristics. The only observable difference is the value of PR . In the case of the same BW_{LoRa} and different SF_{LoRa} , we observe curious results. For configuration where $BW_{LoRa} = 400$ kHz and $SF_{LoRa} = 12$ we reach at the center frequency $PR_{10\%PER} = -40$ dB. In contrast, for configuration with $BW_{LoRa} = 400$ kHz and $SF_{LoRa} = 5$ we receive the value of $PR_{10\%PER} = -21$ dB. It means higher BW of LoRa has a negative impact on immunity against interfering Wi-Fi signal.

The last graphical representation in this subsection, figure 7-3, describes the difference in dependency of parameter PR on the value of Δf for the LoRa signal using the highest $BW_{LoRa} = 1600$ kHz. The figure demonstrates that with increasing frequency offset parameter PR is decreasing in all parameter setups moderately until the critical value of $\Delta f = 6$ MHz. Despite the similarity between characteristics, we can detect a significant decrease in PR . In this case, the signal with four-times higher BW , value of PR is higher by 10 dB for both limit values of SF ($PR_{10\%PER}$ (for $SF_{LoRa} = 12$) = -32 dB and $PR_{10\%PER}$ (for $SF_{LoRa} = 5$) = -11 dB). Pursuant to the received results, we can define that setups with large BW_{LoRa} and low SF_{LoRa} as least resistant to interference in consonance with theoretical expectations.

According to Figs. 7-1, 7-2, and 7-3, we are able to say that SF_{LoRa} and BW_{LoRa} has a significant impact on the LoRa robustness. These conclusions meet with theoretical expectations, presented in [3], [35].

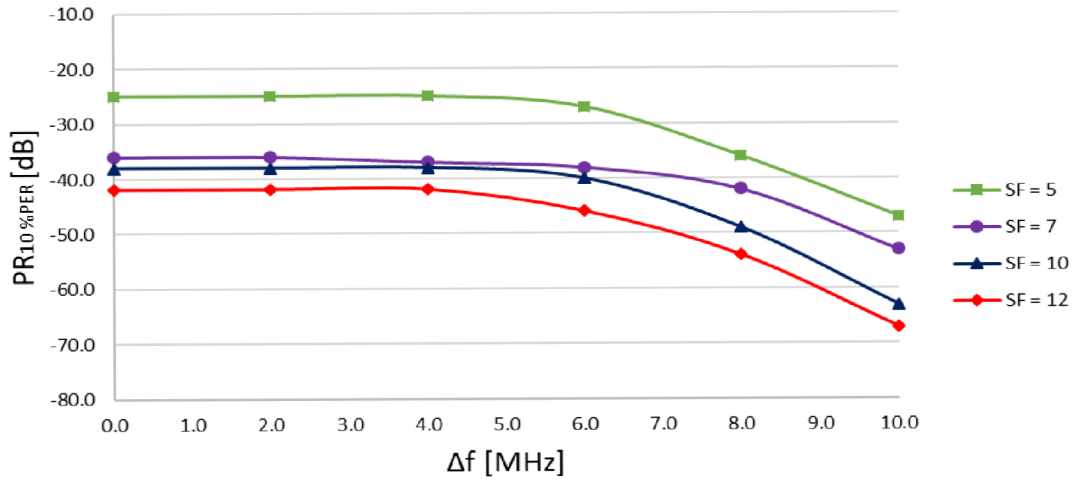

Figure 7-1 PR vs. Δf for $BW_{LoRa} = 200$ kHz LoRa vs. Wi-Fi (802.11b using CCK (DBPSK)), co-channel and in-band coexistence scenarios

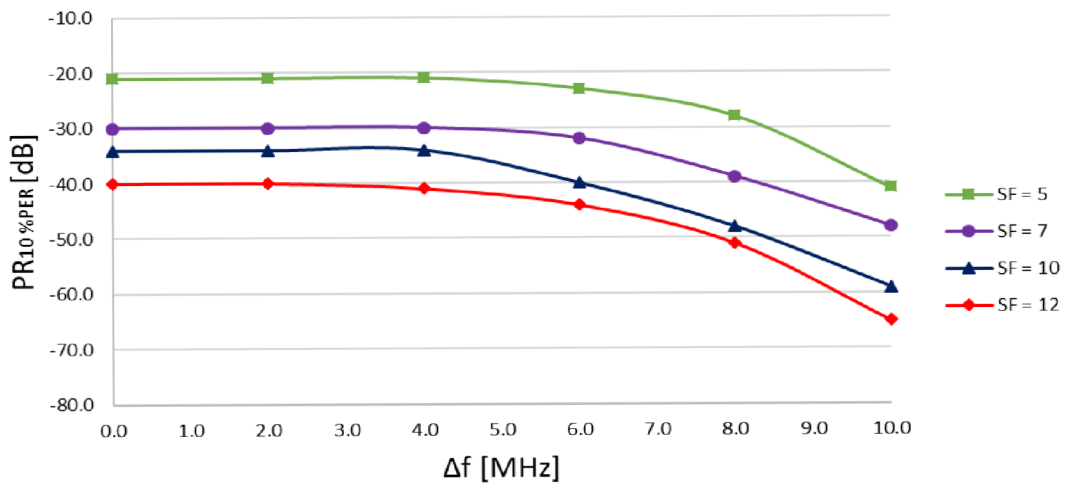

Figure 7-2 PR vs. Δf for $BW_{LoRa} = 400$ kHz LoRa vs. Wi-Fi (802.11b using CCK (DBPSK)), co-channel and in-band coexistence scenarios

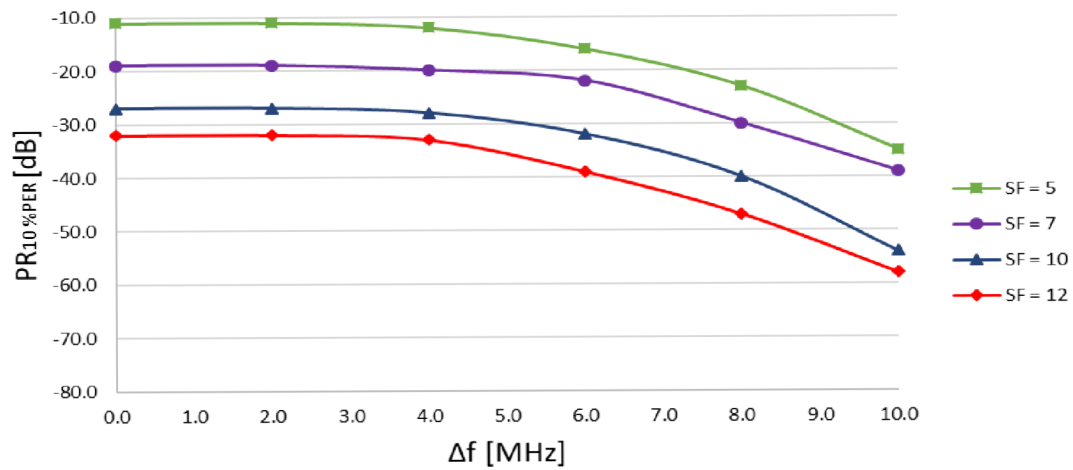

Figure 7-3 PR vs. Δf for $BW_{LoRa} = 1600$ kHz LoRa vs. Wi-Fi (802.11b using CCK (DBPSK)), co-channel and in-band coexistence scenarios

7.1.2 The IEEE 802.11b signal using of CCK (DQPSK)

modulation

The following subchapter presents the results of LoRa and Wi-Fi coexistence measurements for 802.11b based signal using CCK with DQPSK modulation. The data rate of interfering the Wi-Fi signal achieves up to 11 Mbps. Static parameters were the same as in the previous subchapter. Results are presented for the values of SF_{LoRa} (5, 7, 10, and 12).

Figure 7-4 shows the difference in dependency of parameter PR on the value of frequency offset Δf for $BW_{LoRa} = 200$ kHz. In the case of the co-channel scenario, the value of PR lies in the interval from -31 dB to -49 dB, depending on the evaluated setup. With increasing frequency offset in the in-band scenario, parameter PR is decreasing in all parameter setups gradually compared to the configuration with DBPSK modulation. Another curious observation can be derived from figures 7-1 and 7-4, where LoRa vs. IEEE 802.11b using DQPSK modulation achieves better robustness results. While LoRa signal with $BW_{LoRa} = 200$ kHz and $SF_{LoRa} = 12$ against DBPSK modulated Wi-Fi signal reach value of $PR_{10\%PER} = -42$ dB in co-channel scenario, LoRa signal vs. DQPSK modulated signal achieves $PR_{10\%PER} = -49$ dB. This is resulting in the fact that LoRa is more vulnerable to interference caused by a signal with DBPSK modulation.

Figs. 7-5 and 7-6 demonstrate the difference in dependency of parameter PR on the value of frequency offset Δf for $BW_{LoRa} = 400$ kHz and $BW_{LoRa} = 1600$ kHz. Characteristics of co-channel and in-band scenarios are comparable with the previous characteristic shown in figure 7-4. All of these figures show a gradual decrease of PR depending on the higher value of Δf in case of an in-band scenario. Co-channel scenario results follow theoretical expectations and confirm the fact that with rising BW_{LoRa} required $PR_{10\%PER}$ is higher. A similar fact applies to SF_{LoRa} , wherewith decreasing SF number required $PR_{10\%PER}$ is increasing. The same we can apply for in-band scenarios depending on Δf . Interesting to examine is figure 7-6. Even after repeated measurements, there was no noticeable difference in performance between setups with $SF_{LoRa} = 5, 7, \text{ and } 10$ during the in-band scenario. Despite this fact, setup with $SF_{LoRa} = 12$ achieved the lowest PR according to theoretical expectations.

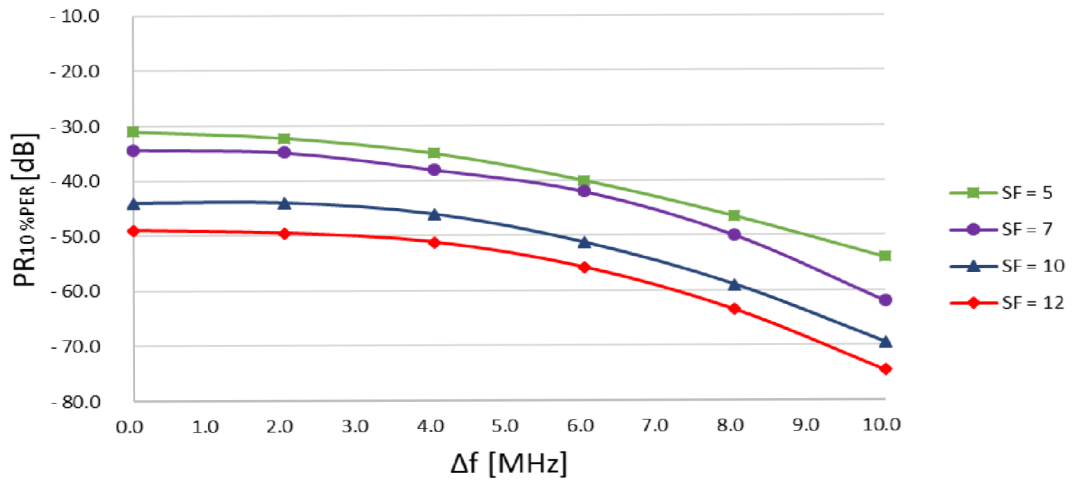

Figure 7-4 PR vs. Δf for $BW_{LoRa} = 200$ kHz LoRa vs. Wi-Fi (802.11b using CCK (DQPSK)), co-channel and in-band coexistence scenarios

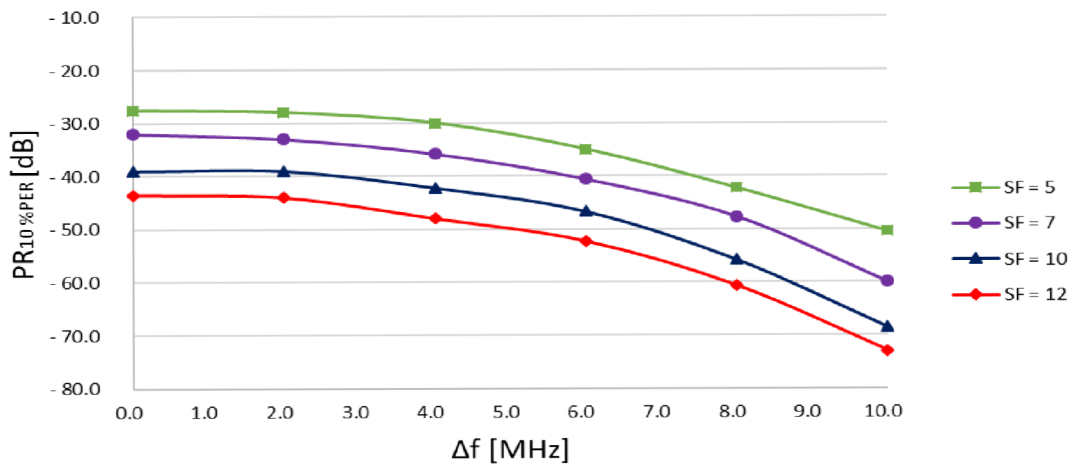

Figure 7-5 PR vs. Δf for $BW_{LoRa} = 400$ kHz LoRa vs. Wi-Fi (802.11b using CCK (DQPSK)), co-channel and in-band coexistence scenarios

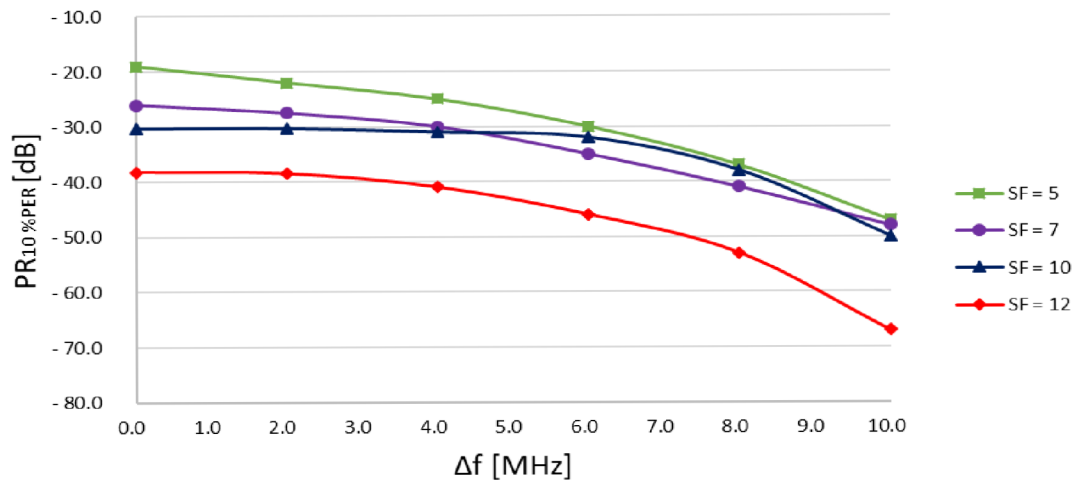

Figure 7-6 PR vs. Δf for $BW_{LoRa} = 1600$ kHz LoRa vs. Wi-Fi (802.11b using CCK (DQPSK)), co-channel and in-band coexistence scenarios

7.2 LoRa vs. Wi-Fi (802.11g)

The second scenario was explored in defined combinations of LoRa system parameters. For all configurations, a payload with a long of 15 Byte was used. The basic setup is shown in the table 7-4.

Parameter	Modulation technique	Modulation	Data rate
Type	PBCC/OFDM	DBPSK/8PSK/BPSK	1/6/22 Mbps

Table 7-4 System parameters of IEEE 802.11g used in the measurement

7.2.1 The IEEE 802.11g signal using of PBCC (DBPSK) modulation

In the following part, the first results of the LoRa vs. 802.11g subsection are introduced. A configuration of LoRa against signals using PBCC with DBPSK modulation is observed. The data rate of interfering the Wi-Fi signal achieves up to 1 Mbps. Static parameters were according to the methodology. Transmission power level of LoRa measured at the receiver = -85 dBm, $CR_{LoRa} = 4/8$, and $BW_{Wi-Fi} = 20$ MHz Results are presented for values of SF_{LoRa} (5, 7, 10, and 12).

In the first part of this subsection, there are presented the results for a dependency of parameter PR on the value of frequency offset Δf for the lowest LoRa BW value, $BW_{LoRa} = 200$ kHz. The results are shown in the figure 7-7 and are corresponding with interfering Wi-Fi signal (based on 802.11b) using CCK and DBPSK modulation, which were presented in the first subsection. In this case, it is interfering Wi-Fi signal (IEEE 802.11g based) using PBCC but with the same modulation. LoRa received slightly better results compared to resistance against signal using CCK. Achieved value of PR moves between -27 dB for setup with $SF_{LoRa} = 5$ and -47 dB for $SF_{LoRa} = 12$. Lower PR values in the co-channel scenario compared to interfering signal using CCK and DBPSK modulation means LoRa is more resistible to Wi-Fi signal using PBCC than CCK for the same modulation. Characteristic concerning in-band scenario displays trend as in the previous case with DBPSK modulation. Therefore, a dependency of PR on Δf is practically unchangeable until the value of $\Delta f = 6$ MHz. After this value curves start to decrease, and with increasing Δf , the required PR is decreasing, too.

The second part demonstrates the difference in dependency of parameter PR on the value of frequency offset Δf for $BW_{LoRa} = 400$ kHz and $BW_{LoRa} = 1600$ kHz in Figs. 7-8 and 7-9. Mentioned characteristics are comparable to the previous characteristic shown in figure 7-7. The only differences are in the value of PR for both co-channel and in-band scenario. An interesting fact is if we compare curves for $SF_{LoRa} = 5$ in figures 7-7,7-8 and 7-9, the difference in the value of PR in a co-channel scenario is between 12dB-15 dB with just change of BW_{LoRa} .

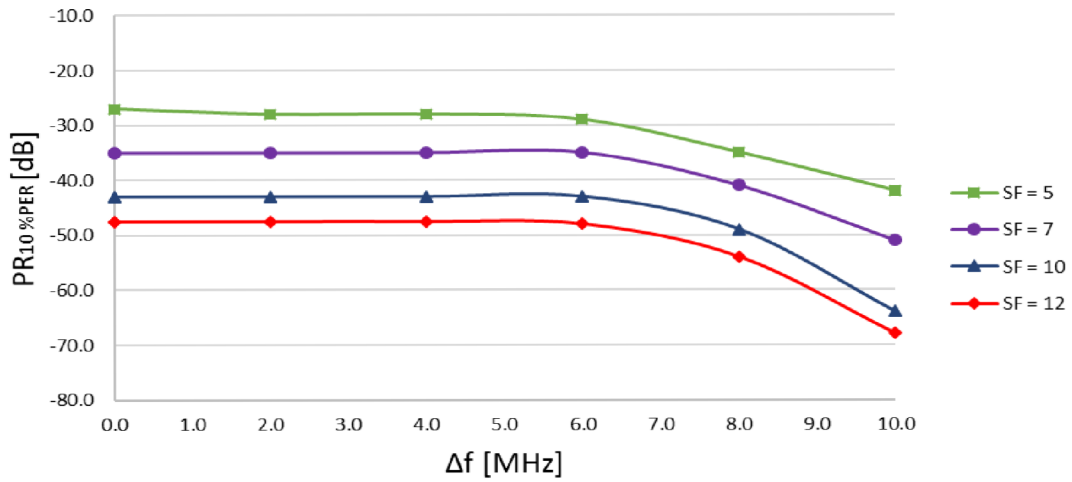

Figure 7-7 PR vs. Δf for $BW_{LoRa} = 200$ kHz LoRa vs. Wi-Fi (802.11g using PBCC (DBPSK)), co-channel and in-band coexistence scenarios

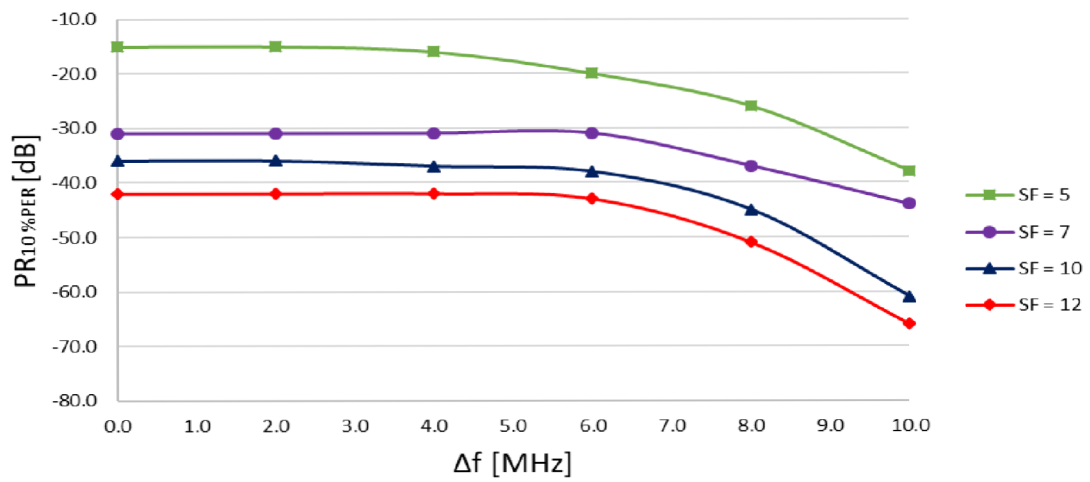

Figure 7-8 PR vs. Δf for $BW_{LoRa} = 400$ kHz LoRa vs. Wi-Fi (802.11g using PBCC (DBPSK)), co-channel and in-band coexistence scenarios

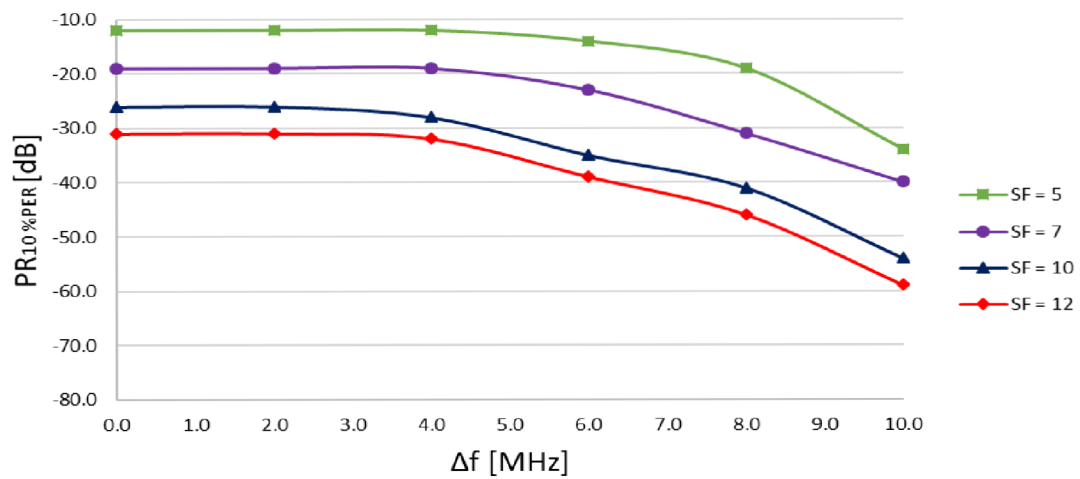

Figure 7-9 PR vs. Δf for $BW_{LoRa} = 1600$ kHz LoRa vs. Wi-Fi (802.11g using PBCC (DBPSK)), co-channel and in-band coexistence scenarios

7.2.2 The IEEE 802.11g signal using of PBCC (8PSK)

modulation

The following subsection presents received results of LoRa and Wi-Fi coexistence measurements another time for 802.11g based signal using PBCC but with different modulation – 8PSK. The data rate of interfering the Wi-Fi signal achieves up to 22 Mbps. Constant parameters were the same as in previous subchapters. The results are presented for values of SF_{LoRa} (5, 7, 10, and 12) in subgraphs for values of BW_{LoRa} (200kHz, 400kHz, and 1600 kHz).

The first figure of this subsection, Figure 7-10, describes the difference in dependency of parameter PR on the value of frequency offset Δf for $BW_{LoRa} = 200$ kHz. In the case of the co-channel scenario, the value of PR lies in the interval (between -20 dB and -41 dB) depending on the evaluated setup. With increasing frequency offset in the in-band scenario, parameter PR is decreasing in all parameter setups moderately until the value of $\Delta f = 8$ MHz. From this point, characteristic acquires steeper trend, and dependency of PR on the value of Δf has significantly decreasing development. Compared to the previous interfering signals with different modulations, characteristics of curves are noticeably resembling. It is noteworthy to examine the curve for $SF_{LoRa} = 5$. This setup achieves the value of PR = -20 dB in the co-channel scenario, which means that for the case with $BW_{LoRa} = 200$ kHz, LoRa is least resistant to interfering signal using PBCC with 8PSK modulation. In general, compared to the previous results (figures 7-1 – 7-10), LoRa is more resistant to interfering signals using modulations DBPSK and 8PSK.

Figure 7-11 demonstrates the difference in dependency of parameter PR on the value of frequency offset Δf for $BW_{LoRa} = 400$ kHz once more for four values of SF_{LoRa} . The figure shows that with increasing frequency offset parameter PR is decreasing in all parameter setups gradually. Falling of characteristics is similar to interfering signal with DQPSK modulation in case of 802.11b based signal using CCK.

The last figure, 7-12, represents the difference in dependency of parameter PR on the value of frequency offset Δf for and $BW_{LoRa} = 1600$ kHz. Characteristics of co-channel and in-band scenario correlate with previous characteristics shown in figure 7-10 and 7-11. All of these curves show a gradual decrease of PR depending on the higher value of Δf in case of an in-band scenario. After observation of previously received results, it could be confirmed that the robustness of LoRa against interfering Wi-Fi signal with modulations 8PSK (PBCC) and DBPSK (CCK) is significantly lower compared to signal with DQPSK (CCK) modulation. A curious fact to observe is the small difference in the value of PR between curves for all selected BW_{LoRa} .

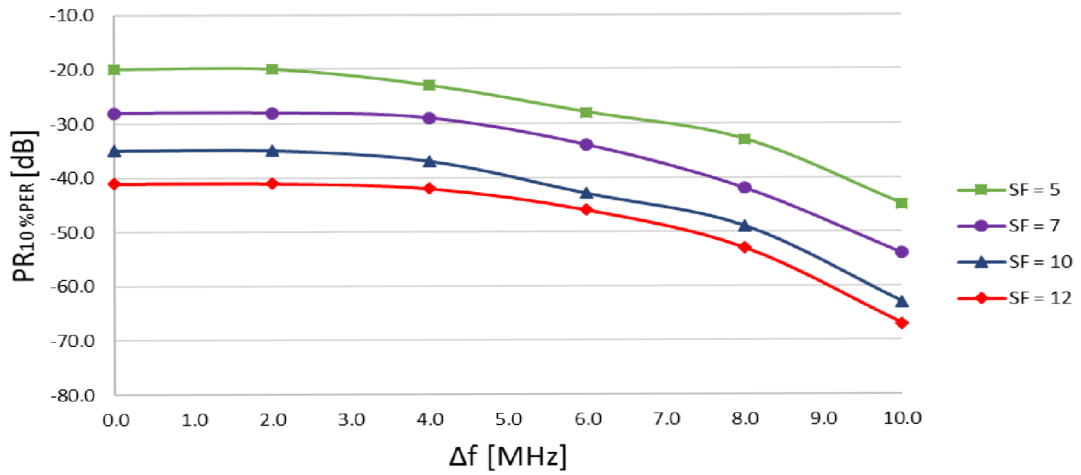

Figure 7-10 PR vs. Δf for $BW_{LoRa} = 200$ kHz LoRa vs. Wi-Fi (802.11g using PBCC (8PSK)), co-channel and in-band coexistence scenarios

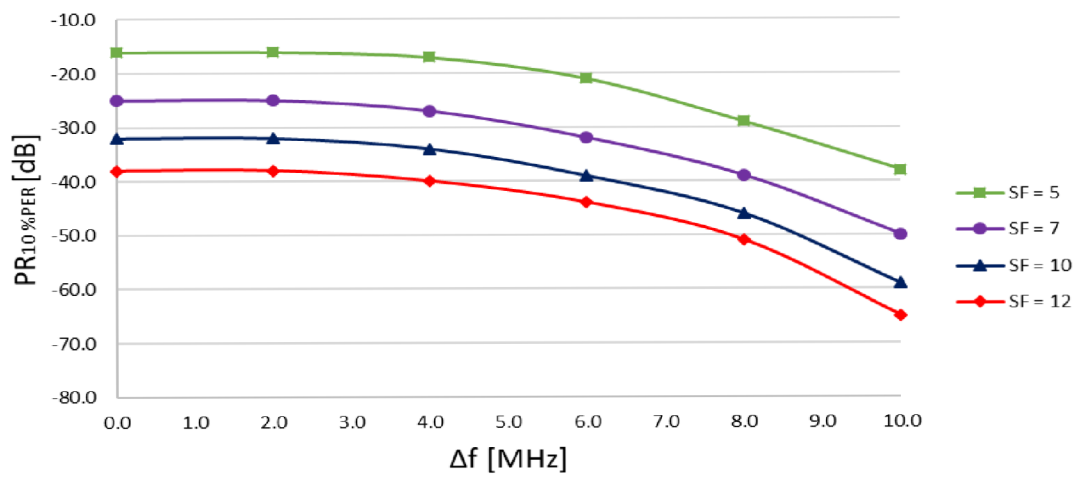

Figure 7-11 PR vs. Δf for $BW_{LoRa} = 400$ kHz LoRa vs. Wi-Fi (802.11g using PBCC (8PSK)), co-channel and in-band coexistence scenarios

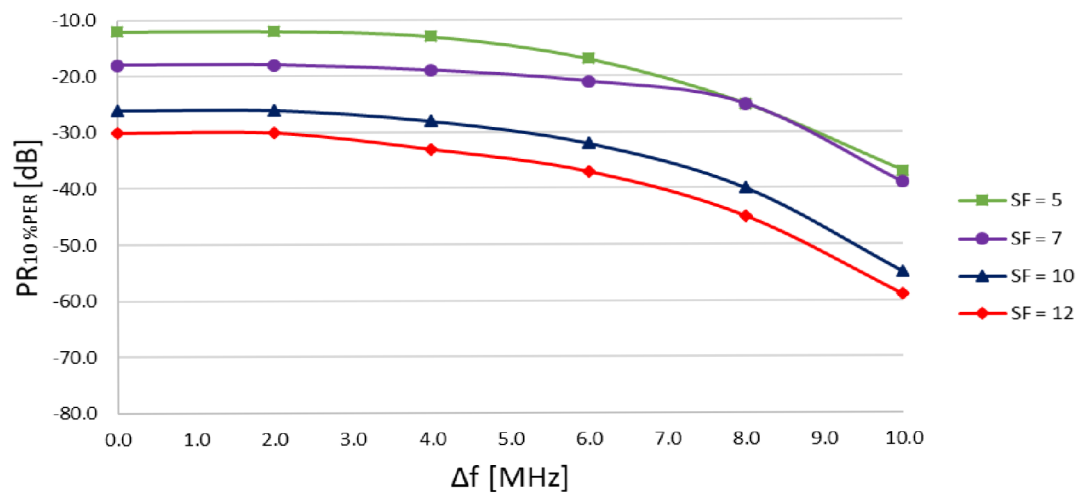

Figure 7-12 PR vs. Δf for $BW_{LoRa} = 1600$ kHz LoRa vs. Wi-Fi (802.11g using PBCC (8PSK)), co-channel and in-band coexistence scenarios

7.2.3 The IEEE 802.11g signal using of OFDM (BPSK)

modulation

The last subchapter dedicated to LoRa vs. 802.11g presents the results of LoRa vs. Wi-Fi coexistence measurements for 802.11g based signal using OFDM with BPSK modulation. The data rate of interfering the Wi-Fi signal achieves up to 6 Mbps. Constant parameters were the same as in previous subchapters. The results are presented for values of SF_{LoRa} (5, 7, 10, and 12) in subgraphs for values of BW_{LoRa} (200kHz, 400kHz, and 1600 kHz).

Figure 7-13 describes the difference in dependency of parameter PR on the value of frequency offset Δf for $BW_{LoRa} = 200$ kHz. In the case of the co-channel scenario, the value of PR lies in the interval from -27 dB to -52 dB, depending on the evaluated setup. With increasing frequency offset in the in-band scenario, parameter PR is constant in all parameter setups until the value of $\Delta f = 8$ MHz. Compared to the previous tests (figures 7-1, 7-4, 7-7, and 7-10), curves are partially different and start to fall down only at high values of Δf , specifically from $\Delta f = 8$ MHz up. From this point, characteristic acquires precipitous trend, and the dependency of PR on the value of Δf has significantly decreasing development. In the area of bandwidth side values, Wi-Fi interfering signal has a negligible impact on LoRa. In fact, this characteristic is typical for standards using OFDM, in consonance with [35]. The setup with $SF_{LoRa} = 12$ reaches a value of $PR_{10\%PER} = -52$ dB at center frequency ($\Delta f = 0$ MHz). An interesting thing to mention is a high level of LoRa robustness in the co-channel and main part of the in-band scenario for this setup compared to robustness against other interfering signals. On the other hand, setup with low SF_{LoRa} is less resistant to interference and reaches a value of $PR_{10\%PER} = -27$ dB at a center frequency for maintaining reliable communication. Setups with $SF_{LoRa} = 7$ and 10 are within the borders proposed by these two limit values.

Figs. 7-14 and 7-15 demonstrate the difference in dependency of parameter PR on the value of frequency offset Δf for $BW_{LoRa} = 400$ kHz and $BW_{LoRa} = 1600$ kHz. Characteristics of co-channel and in-band scenarios correlate with the previous characteristic shown in figure 7-13 and have the same development. Differences are only in the value of PR for both co-channel and in-band scenario. Specifically, while in the case of $BW_{LoRa} = 400$ kHz, PR varies in one of dB from PR of $BW_{LoRa} = 200$ kHz, for $BW_{LoRa} = 1600$ kHz PR changes in more than 10 dB for the same SF_{LoRa} .

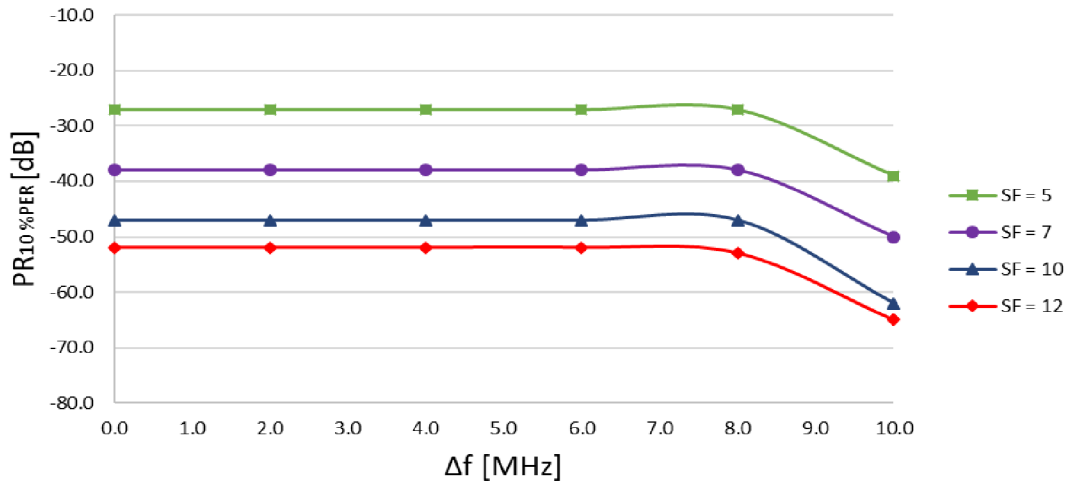

Figure 7-13 PR vs. Δf for $BW_{LoRa} = 200$ kHz LoRa vs. Wi-Fi (802.11g using OFDM (BPSK)), co-channel and in-band coexistence scenarios

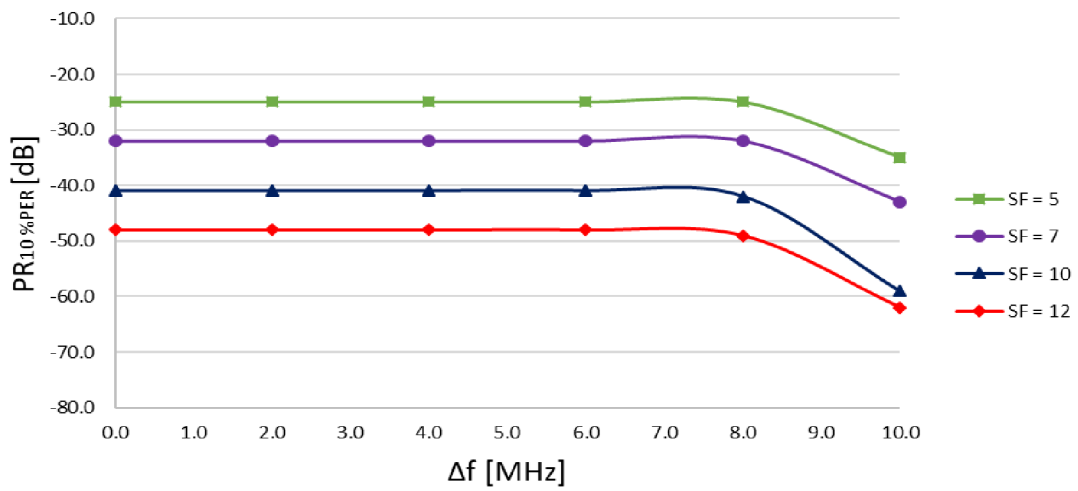

Figure 7-14 PR vs. Δf for $BW_{LoRa} = 400$ kHz LoRa vs. Wi-Fi (802.11g using OFDM (BPSK)), co-channel and in-band coexistence scenarios

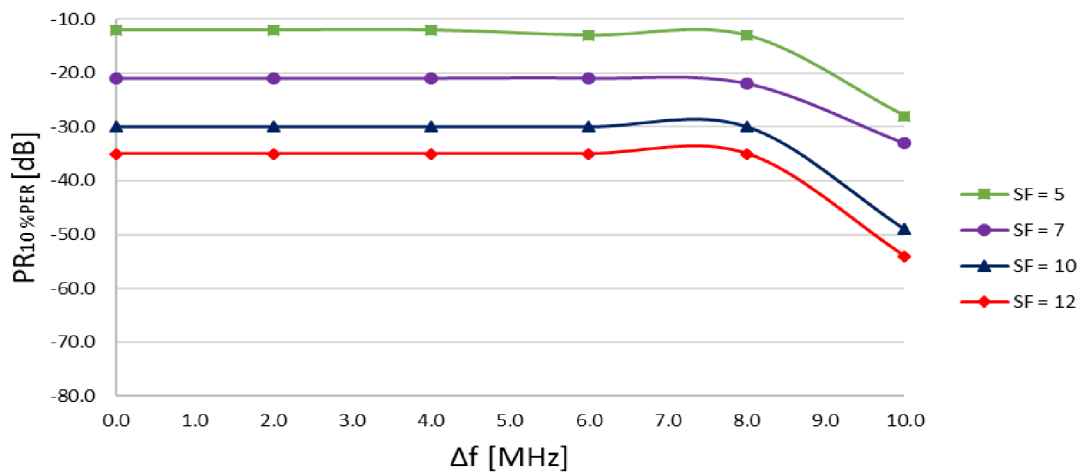

Figure 7-15 PR vs. Δf for $BW_{LoRa} = 1600$ kHz LoRa vs. Wi-Fi (802.11g using OFDM (BPSK)), co-channel and in-band coexistence scenarios

7.3 LoRa vs. Wi-Fi (802.11n)

Introduced the last scenario that was explored in defined combinations of LoRa system parameters. For all configurations, a payload with a long of 15 Byte was used. The basic configuration is shown in the table (7-5).

Parameter	Modulation technique	Modulation	Data rate
Type	OFDM	64QAM	54 Mbps

Table 7-5 System parameters of IEEE 802.11n used in the measurement

7.3.1 The IEEE 802.11n signal using of OFDM (64QAM)

modulation

The last subsection presents results of LoRa and Wi-Fi coexistence measurements for 802.11n based signal using OFDM with 64QAM modulation. The data rate of interfering the Wi-Fi signal achieves up to 54 Mbps. Static parameters were according to the methodology. Transmission power level of LoRa was measured on input of receiver = -85 dBm, $CR_{LoRa} = 4/8$, and $BW_{Wi-Fi} = 20$ MHz. Results are presented for the values of SF_{LoRa} (5, 7, 10, and 12).

The first figure of this subsection, figure 7-16, describes the difference in dependency of parameter PR on the value of frequency offset Δf for $BW_{LoRa} = 200$ kHz. In the first case (co-channel scenario), the PR reach value from -50 dB up to -27 dB. These results correlate with the results from the previous subchapter and interfering standard 802.11g using OFDM. Characteristic has the same graphical development with a breaking point at the same value of $\Delta f = 8$ MHz. From this value, curves are significantly decreasing as in the previous case. From the examined results, the robustness of LoRa against Wi-Fi signal using OFDM is constant, almost in the whole bandwidth, compared to Wi-Fi signals using CCK or PBCC. After reaching extreme values of Wi-Fi bandwidth (rising Δf around 10 MHz), the robustness of LoRa is growing, too, as in previous measurements.

Figure 7-17 demonstrates the difference in dependency of parameter PR on the value of frequency offset Δf for $BW_{LoRa} = 400$ kHz for all four values of SF_{LoRa} . The figure shows that with increasing frequency, offset parameter PR is constant in all parameter setups till the value of $\Delta f = 8$ MHz. From this point, we can observe a decrease in dependency of PR on Δf . Falling of characteristics corresponds to the interfering signal with BPSK modulation in the case of 802.11g based signal using OFDM.

The last figure 7-18 represents the difference in dependency of parameter PR on the value of frequency offset Δf for and $BW_{LoRa} = 1600$ kHz. Characteristics of co-channel and in-band scenario are similar to previous characteristics shown in figure 7-16 and 7-17. All of these curves are constant in an in-band scenario until the mentioned value of

$\Delta f = 8$ MHz. In consonance with previously mentioned results, it can be verified that the robustness of LoRa against interfering Wi-Fi signal with modulations 8PSK (PBCC) and DBPSK (CCK) is significantly lower compared to signal with DQPSK (CCK) modulation. The results of LoRa vs. Wi-Fi interfering signal using OFDM (802.11g and 802.11n) are located in an interval between the previously mentioned results of robustness.

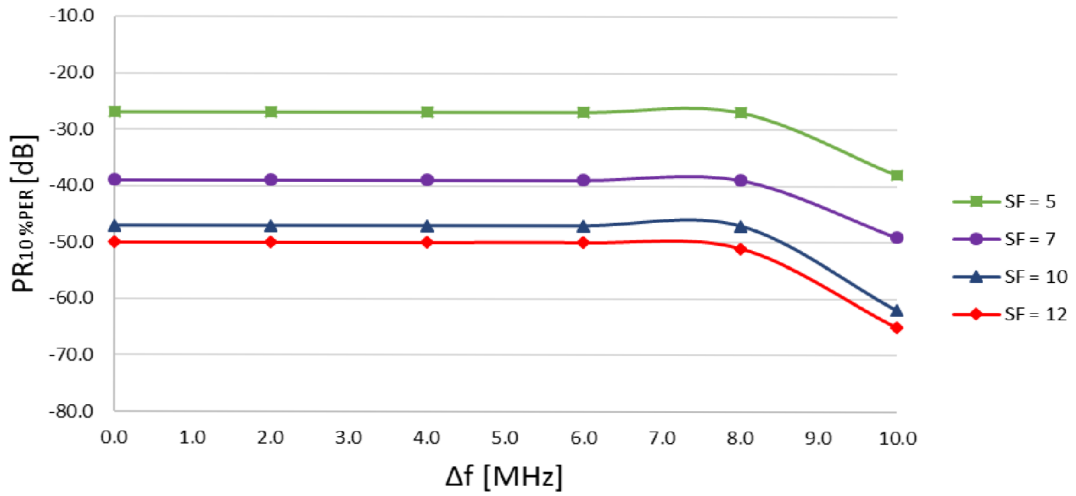

Figure 7-16 PR vs. Δf for $BW_{LoRa} = 200$ kHz LoRa vs. Wi-Fi (802.11n using OFDM (64QAM)), co-channel and in-band coexistence scenarios

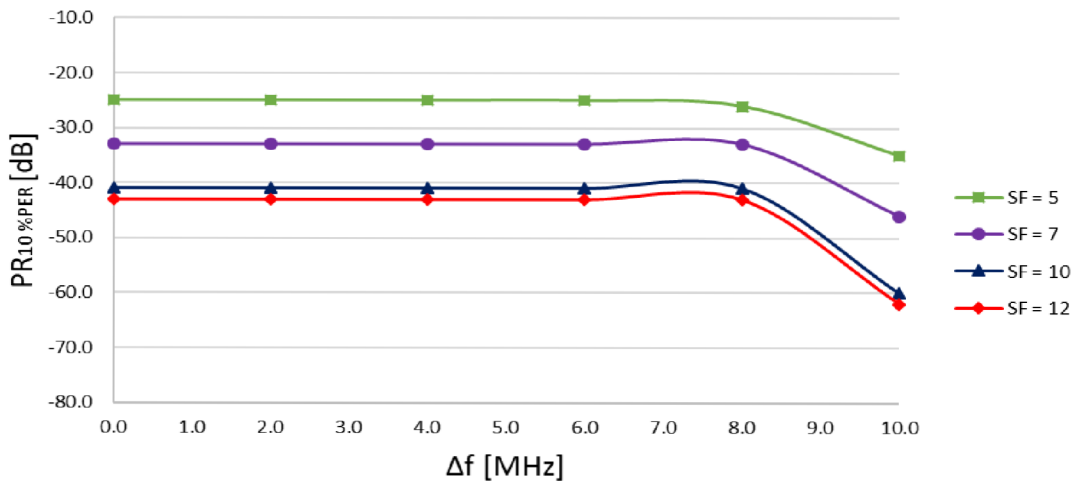

Figure 7-17 PR vs. Δf for $BW_{LoRa} = 400$ kHz LoRa vs. Wi-Fi (802.11n using OFDM (64QAM)), co-channel and in-band coexistence scenarios

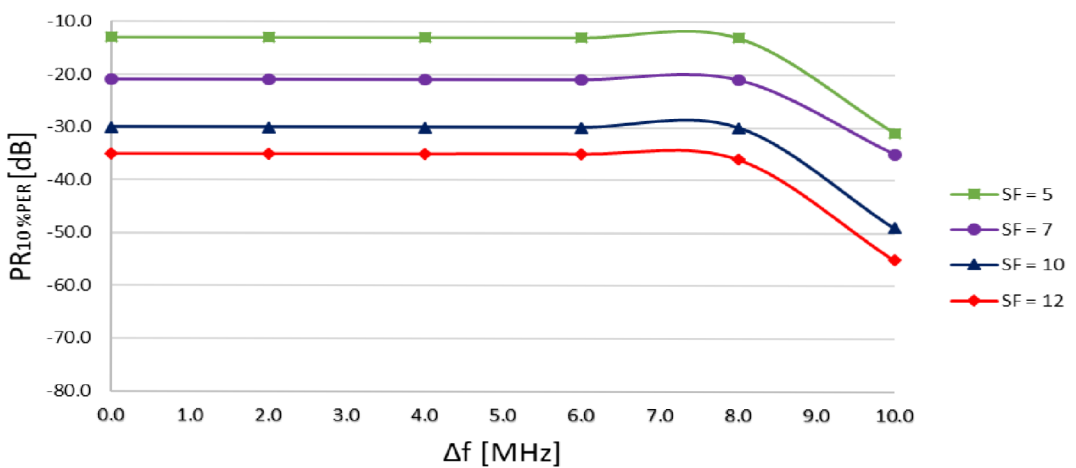

Figure 7-18 PR vs. Δf for $BW_{LoRa} = 1600$ kHz LoRa vs. Wi-Fi (802.11n using OFDM (64QAM)), co-channel and in-band coexistence scenarios

7.4 Summary of the results and comparison with related works

In the following subchapter, there are briefly commented the obtained results of both coexistence scenarios analysis (co-channel and in-band) for all LoRa selected system parameter setups and selected interfering signals. The first of them is a co-channel scenario result shown in table 7-6. From the results, it can be determined, LoRa is more vulnerable to Wi-Fi signals based on 802.11b and more resistant to signals based on 802.11g/n. Interesting to observe is the difference between the least and the most resistant setup (SF = 5, BW = 1600 kHz; SF = 12, BW = 200 kHz) for lower value of Δf (0-6 MHz). In the case of CCK/PBCC modulation techniques, the gap between them is up to 30 dB. However, in the case of the OFDM technique, this gap reaches 40 dB.

LoRa system configuration	Interfering Wi-Fi signal (standard and modulation)					
	802.11b CCK (DBPSK)	802.11b CCK (DQPSK)	802.11g PBCC (DBPSK)	802.11g PBCC (8PSK)	802.11g OFDM (BPSK)	802.11n OFDM (64QAM)
	PR _{10%PER} [dB]					
SF=5; BW=1600 kHz	-11	-19	-12	-12	-12	-13
SF=5; BW=400 kHz	-21	-27.6	-15	-16	-25	-25
SF=5; BW=200 kHz	-25	-31	-27	-20	-27	-27
SF=7; BW=1600 kHz	-19	-26	-19	-18	-21	-21
SF=7; BW=400 kHz	-30	-32	-31	-25	-32	-33
SF=7; BW=200 kHz	-36	-34.3	-35	-28	-38	-39
SF=10; BW=1600 kHz	-27	-30.3	-26	-26	-30	-30
SF=10; BW=400 kHz	-34	-39	-36	-32	-41	-41
SF=10; BW=200 kHz	-38	-44	-43	-35	-47	-47
SF=12; BW=1600 kHz	-32	-38.2	-31	-30	-35	-35
SF=12; BW=400 kHz	-40	-43.5	-42	-38	-48	-43
SF=12; BW=200 kHz	-42	-49	-47.5	-41	-52	-50

Table 7-6 LoRa vs. Wi-Fi PR_{10%PER} for $\Delta f = 0$ MHz

In comparison with other studies, probably the best case to compare with could be the application note on the Wi-Fi immunity against LoRa from Semtech [3]. As the objective metric is used as in our case, C/I for the value of PER = 10% for maintaining reliable communication. Under the evaluation there are four cases with side values of the LoRa parameters and one with the different LoRa modulation. The results are reported as the relative power difference between a carrier and an interfering signal in a co-channel coexistence scenario. The outputs of this work show similar behavior of LoRa being interfered by Wi-Fi signals. LoRa is more vulnerable to signals using PBCC (with DBPSK/8PSK modulation) and is more resistant against the signals using OFDM (using BPSK/64QAM). This validates our measurements. The study also confirms that LoRa achieves the most promising results against Wi-Fi signals with small values of BW_{LoRa} and higher numbers of SF_{LoRa} . With the decreasing SF_{LoRa} and increasing BW_{LoRa} , the robustness of LoRa is dropping. In case of in-band scenario that was explored, setup with

$SF_{LoRa} = 12$ and $BW_{LoRa} = 200$ kHz (configuration supposed to be the most immune against interference), Characteristic of C/I values depending on frequency offset have the same trend as in our case, decreasing till the value of $\Delta f = 6$ MHz moderately, then significantly.

In the case of [35], a comparison is not possible in the same way. It is caused by the use of BER instead of PER, and in using values of LoRa parameters required by a sub- 1 GHz band (for 2.4 GHz ISM band LoRa has different options compared to a sub-GHz band like BW_{LoRa} or SF_{LoRa}). On the other hand, the results have the same trend. LoRa is more resistant to OFDM modulated interfering signals, especially in a co-channel scenario, while it is more vulnerable to CCK/PBCC modulated signals. The only exception is the already mentioned DQPSK. The output of the study also reveals the behavior of LoRa vs. Wi-Fi signal using OFDM. LoRa immunity is constant almost in the whole BW_{Wi-Fi} , which confirms our measured results. System parameters of LoRa (BW_{LoRa} and SF_{LoRa}) were validated to have a significant influence on LoRa robustness. Setups with a high value of SF_{LoRa} and low BW_{LoRa} proved the high capability of robustness. On the other hand, LoRa setups higher BW_{LoRa} , and lower SF_{LoRa} are more vulnerable to interference.

Next tables 7-7 and 7-8 show the values of PR for a critical value of Δf ($\Delta f = 6$ MHz) and extreme value of Δf ($\Delta f = 10$ MHz). With the increasing value of Δf , the value of PR is decreasing, and therefore LoRa is more resistant to interference. The only exception is OFDM based signals. In these cases, the resistance of the LoRa signal is constant, almost in the whole bandwidth of Wi-Fi, and starts decreasing significantly from a high value of Δf ($\Delta f = 8$ MHz). This behavior is also verified [35].

LoRa system configuration	Interfering Wi-Fi signal (standard and modulation)					
	802.11b CCK (DBPSK)	802.11b CCK (DQPSK)	802.11g PBCC (DBPSK)	802.11g PBCC (8PSK)	802.11g OFDM (BPSK)	802.11n OFDM (64QAM)
	PR _{10%PER} [dB]					
SF=5; BW=1600 kHz	-16	-30	-14	-17	-13	-13
SF=5; BW=400 kHz	-23	-35	-20	-21	-25	-25
SF=5; BW=200 kHz	-27	-40	-29	-28	-27	-27
SF=7; BW=1600 kHz	-22	-35	-23	-21	-22	-21
SF=7; BW=400 kHz	-32	-40.6	-31	-32	-32	-33
SF=7; BW=200 kHz	-38	-42	-35	-34	-38	-39
SF=10; BW=1600 kHz	-32	-32	-35	-32	-30	-30
SF=10; BW=400 kHz	-40	-46.7	-38	-39	-42	-41
SF=10; BW=200 kHz	-40	-51.3	-43	-43	-47	-47
SF=12; BW=1600 kHz	-39	-46	-39	-37	-35	-35
SF=12; BW=400 kHz	-44	-52.3	-43	-44	-48	-43
SF=12; BW=200 kHz	-46	-55.8	-48	-46	-52	-50

Table 7-7 LoRa vs. Wi-Fi PR_{10%PER} for $\Delta f = 6$ MHz

LoRa system configuration	Interfering Wi-Fi signal (standard and modulation)					
	802.11b CCK (DBPSK)	802.11b CCK (DQPSK)	802.11g PBCC (DBPSK)	802.11g PBCC (8PSK)	802.11g OFDM (BPSK)	802.11n OFDM (64QAM)
	PR _{10%PER} [dB]					
SF=5; BW=1600 kHz	-35	-47	-34	-37	-28	-31
SF=5; BW=400 kHz	-41	-50.5	-38	-38	-35	-35
SF=5; BW=200 kHz	-47	-54	-42	-45	-39	-38
SF=7; BW=1600 kHz	-39	-48	-40	-39	-33	-35
SF=7; BW=400 kHz	-48	-60	-44	-50	-43	-46
SF=7; BW=200 kHz	-53	-62	-51	-54	-50	-49
SF=10; BW=1600 kHz	-54	-50	-54	-55	-49	-49
SF=10; BW=400 kHz	-59	-68.5	-61	-59	-59	-60
SF=10; BW=200 kHz	-63	-69.5	-64	-63	-62	-62
SF=12; BW=1600 kHz	-58	-67	-59	-59	-54	-55
SF=12; BW=400 kHz	-65	-73	-66	-65	-62	-62
SF=12; BW=200 kHz	-67	-74.5	-68	-67	-65	-65

Table 7-8 LoRa vs. Wi-Fi PR_{10%PER} for $\Delta f = 10$ MHz

8. CONCLUSION

This thesis dealt with the measurement of coexistence that can occur between the LoRa and Wi-Fi systems in the non-licensed 2.4 GHz ISM band.

In the first part of this thesis, wireless systems LoRa and Wi-Fi (802.11 standard) were described from the view of a PHY, band, and operational frequencies. Pursuant to these parameters and characteristics, the common radiofrequency band was defined where LoRa and Wi-Fi can coexist. According to the purpose of the thesis, measurements setup or testbed was designed in the area of mobile and wireless communications lab as a part of DREL FEEC BUT using equipment loaned from this department. For the purpose of future measurements, an appropriate method was proposed and verified with a focus on PER and C/I parameters as the objective metric. The multiple coexistence scenarios were proposed to find the best scenario in which the mentioned wireless systems can coexist. Experimental measurements focused on co-channel and in-band scenarios were performed.

Measurements were performed for multiple setups, including selected values of BW_{LoRa} and SF_{LoRa} . LoRa was interfered by various interfering signals with different modulations. From the received results, we can observe the significant influence of the mentioned LoRa system parameters on coexistence. Another vital factor was the influence of frequency offset (Δf), power level, modulation technique, and modulation of interfering Wi-Fi signal. The description and representation of received results are included in the evaluated analysis of measurements. As the most resistant configurations (and the most suitable for coexistence) were defined the settings with a high value of SF_{LoRa} and low value of BW_{LoRa} . A Laboratory work for educational purposes in the Laboratory of Mobile and Wireless Communications was prepared.

The thesis bases the ground for future research of LoRa and Wi-Fi coexistence. For the next research, it is worth to mention some ideas in which it could be curious to continue. First of them could be the last coexistence scenario and its measurement, out-band coexistence scenario for all the LoRa and Wi-Fi system parameter combinations. An interesting way to explore coexistence between LoRa and Wi-Fi in depth could be a higher number of measured configurations, including evaluation of a higher number of LoRa system parameters (different modulation – GFSK, an additional value of $BW = 800$ kHz). Another idea is automatization of the measurement process (automatic evaluation of measured data from log files) or focus on different modes of Wi-Fi transmission – burst mode. The most impressive part to examine could be a measurement in real conditions (using antennas) and measurement of Wi-Fi robustness against LoRa.

A part of this thesis was presented on the student conference EEICT 2020 [36].

9. REFERENCES

- [1] LORA ALLIANCE. *LoRaWAN™, A technical overview of LoRa® and LoRaWAN™* [online]. 2015 [cit. 2019]. Dostupné z: <https://loralliance.org/sites/default/files/2018-04/what-is-lorawan.pdf>
- [2] WALKE, Bernhard, Stefan MANGOLD a Lars BERLEMANN. *IEEE 802 wireless systems: protocols, multi-hop mesh/relaying, performance and spectrum coexistence*. Hoboken, NJ, 2006. ISBN 04-700-1439-3.
- [3] SEMTECH. *Application Note: Wi-Fi Immunity of LoRa® at 2.4 GHz* [online]. 2017 [cit. 2019]. Dostupné z: https://semtech.my.salesforce.com/sfc/p/#E0000000JelG/a/44000000MDcO/Ll4bon.4HPwcyXv9fegcfcbpVLYd7Lx_aZLMzYNLIQ
- [4] VISWANATHAN, Sathish. Tutorial on 802.11n PHY layer : Part 3: 802.11n transmitter. *Edn.com* [online]. [cit. 2019-12-10]. Dostupné z: <https://www.edn.com/design/microwave-rf-design/4012676/Tutorial-on-802-11n-PHY-layer--Part-3>
- [5] *IEEE Explore: IEEE GET Program™ GET 802(R) Standards* [online]. IEEE, 2019 [cit. 2019-12-13]. Dostupné z: https://ieeexplore.ieee.org/browse/standards/get-program/page/series?id=68&utm_source=lp_wdw&utm_campaign=80211&utm_medium=std&utm_term=80211m%3Dstd&utm_term=80211
- [6] YANG XIAO, Yi. *EMERGING WIRELESS LANs, WIRELESS PANs AND WIRELESS MANs*. New Jersey: John Wiley & Sons, Inc., Hoboken, New Jersey, 2013.
- [7] MAHMOUD, Mahmoud a Auday MOHAMAD. A Study of Efficient Power Consumption Wireless Communication Techniques/ Modules for Internet of Things (IoT) Applications. *SchematicsScholar.org* [online]. [cit. 2019]. Dostupné z: <https://www.semanticscholar.org/paper/A-Study-of-Efficient-Power-Consumption-Wireless-for-Mahmoud-Mohamad/a7d97b5a2c157365f1a7c0bdad93d35b7e2871f3>

- [8] LORA ALLIANCE & WBA, IOT WORK GROUP. *Wi-Fi & LoRaWAN® Deployment Synergies* [online]. 2019 [cit. 2019]. Dostupné z: <https://lora-alliance.org/sites/default/files/2019-09/wi-fi-and-lorawanr-deployment-synergies.pdf>
- [9] SEMTECH. Semtech SX1280. *Semtech.com* [online]. [cit. 14]. Dostupné z: <https://www.semtech.com/products/wireless-rf/24-ghz-transceivers/sx1280>
- [10] EXPLORATORY ENGINEERING. Exploratory engineering. *Data Rate and Spreading Factor of LoRa* [online]. [cit. 2019]. Dostupné z: https://docs.exploratory.engineering/lora/dr_sf/
- [11] *LoRa Physical Layer & RF Interface* [online]. electronics-notes.com [cit. 2019-12-10]. Dostupné z: <https://www.electronics-notes.com/articles/connectivity/lora/radio-rf-interface-physical-layer.php>
- [12] LORA ALLIANCE TECHNICAL COMMITTEE. *LoRaWAN™ 1.1 Specification* [online]. [cit. 25]. Dostupné z: https://lora-alliance.org/sites/default/files/2018-04/lorawantm_specification_v1.1.pdf
- [13] ZANDL, Patrick. *Bezdrátové sítě WiFi: praktický průvodce*. Brno: Computer Press, 2003. ISBN 80-722-6632-2.
- [14] SANTAMARÍA, A. a F. LÓPEZ-HERNÁNDEZ. *Wireless LAN standards and applications*. Boston: Artech House, 2001. Artech House mobile communications series. ISBN 08-900-6943-3.
- [15] DAŘÍLEK, Martin. *Standardy 802.11e a 802.11i*. Ostrava: Vysoká škola baňská. Dostupné také z: http://www.cs.vsb.cz/grygarek/TPS/projekty/0506Z/tps_dar022.pdf
- [16] BUCHTA, Marek. *Efektivita bezdrátových sítí z pohledu služeb*. Brno, 2016.. Diplomová práce. Vysoké učení technické v Brně, Fakulta elektrotechniky a komunikačních technologií. Vedoucí práce Doc. Ing. VLADISLAV ŠKORPIL, CSc.

- [17] POOLE, Ian. *IEEE 802.11 Wi-Fi Standards* [online]. [cit. 2019]. Dostupné z: <https://www.electronics-notes.com/articles/connectivity/wifi-ieee-802-11/standards.php>
- [18] *802.11b Standard: 802.11b Standard Physical layer* [online]. [cit. 2019-12-10]. Dostupné z: <https://www.rfwireless-world.com/Articles/802.11b-1999.html>
- [19] PRAVDA, I. *Přehled doplňků standardu IEEE 802.11* [online]. [cit. 2019]. Dostupné z: <http://access.feld.cvut.cz/>
- [20] *Grandmetric.com: 4. Wi-Fi Fundamentals: RF and PHY* [online]. Poznaň: GRANDMETRIC, 2018 [cit. 2019-12-13]. Dostupné z: <https://www.grandmetric.com/topic/4-wi-fi-fundamentals-rf-and-phy/>
- [21] ZANDL, Patrick. *WiFi Praktický průvodce*. Brno: Computer Press, 2003.
- [22] *IEEE Communications Magazine: New High Rate Wireless LAN Standards*. 1999. Dostupné z: <http://www.jorianvannee.nl/wifi/>
- [23] LIESKOVAN, Tomáš. *MODERNÍ TRENDY V ZABEZPEČENÍ WI-FI SÍTÍ STANDARDU IEEE 802.11*. Brno, 2015.. BAKALÁŘSKÁ PRÁCE. Vysoké učení technické v Brně, Fakulta elektrotechniky a komunikačních technologií. Vedoucí práce Ing. Pavel Endrle.
- [24] *High Performance Browser Networking: WiFi PERFORMANCE OF WIRELESS NETWORKS, CHAPTER 6* [online]. O'Reilly Media, Inc., 2013 [cit. 2019-12-13]. Dostupné z: <https://hpbn.co/wifi/>
- [25] SHERMAN, Matthew. Concerning the Definition of Coexistence: IEEE P802.0 Coexistence Study Group. In: *COEX IEEE P802.15* [online]. 2002, s. 16 [cit. 2019-12-10].
- [26] SHELLHAMMER, Steve. [27] *IEEE 802.15-99/088r2: Coexistence Task Group Charter (power point presentation)*. 1999.
- [27] [26] *IEEE COEX-006r0: IEEE 802 Coexistence SG Meeting Minutes*. 2002.
- [28] *IBM Knowledge Center: Understanding coexistence* [online]. [cit. 2019-12-10]. Dostupné z:

https://www.ibm.com/support/knowledgecenter/en/SSLTBW_2.2.0/com.ibm.zos.v2r2.e0zb100/undcoex.htm

- [29] IMST GMBH. SK-iM282A – Long Range Radio Starter Kit. *Wireless-solutions.de* [online]. [cit. 14]. Dostupné z: <https://www.wireless-solutions.de/products/starterkits/sk-im282a.html>
- [30] ROHDE & SCHWARZ. R&S®FSQ Signal Analyzer. *Rohde-schwarz.com* [online]. [cit. 24]. Dostupné z: https://www.rohde-schwarz.com/cz/product/fsq-productstartpage_63493-7994.html
- [31] ROHDE & SCHWARZ. R&S®SMU200A Vector Signal Generator. *https://www.rohde-schwarz.com/* [online]. [cit. 24]. Dostupné z: https://www.rohde-schwarz.com/cz/product/smu200a-options_63490-7555.html
- [32] IMST GMBH. IM282A-L - Long Range Radio Module. *Wireless-solutions.de* [online]. [cit. 4]. Dostupné z: https://www.wireless-solutions.de/downloads/Radio-Modules/iM282A/WiMOD_LR/WiMOD_LR_Base_Plus_Feature_Spec_V1_1.pdf
- [33] POTOČNÁK, Martin. *Koexistence systému LTE a LoRa v ISM pásmu 2.4 GHz*. Brno, 2019.. Diplomová práce. Vysoké učení technické v Brně, Fakulta elektrotechniky a komunikačních technologií. Vedoucí práce Doc. Ing. Ladislav Polák, Ph.D.
- [34] POPESCU, Vlad, Mauro FADDA, Maurizio MURRONI, Javier MORGADE a Pablo ANGUEIRA. Co-Channel and Adjacent Channel Interference and Protection Issues for DVB-T2 and IEEE 802.22 WRAN Operation. *IEEE TRANSACTIONS ON BROADCASTING*. 2014, **4**(60), 8.
- [35] POLAK, Ladislav a Jiri MILOS. Performance analysis of LoRa in the 2.4 GHz ISM band: coexistence issues with Wi-Fi. *Telecommunication Systems*. **2020**. DOI: 10.1007/s11235-020-00658-w. ISSN 1018-4864. Dostupné z: <http://link.springer.com/10.1007/s11235-020-00658-w>
- [36] KAUČIARIK, Filip. *COEXISTENCE OF LORA AND WI-FI IN THE 2.4 GHZ BAND: Proceedings of the 26 th Conference STUDENT EEICT*

2020 [online]. 26. Brno: Vysoké učení technické v Brně, Fakulta elektrotechniky a komunikačních technologií, 2020 [cit. 2020-05-24]. Dostupné z: https://conf.feec.vutbr.cz/eeict/index/pages/view/ke_stazeni

LIST OF APPENDICES

APPENDIX A - LABORATORY WORK	62
APPENDIX B - MODEL REPORT	68
APPENDIX C – MEASURED DATA ON CD.....	71

APPENDIX A - Laboratory Work

Mobile Communication Systems (MSMK)

Laboratory work

Measurement of Coexistence between LoRa and Wi-Fi in 2.4 GHz

The purpose of this laboratory work is to get familiar with the idea of wireless systems coexistence between LoRa and Wi-Fi and its measurement. In the first part, get familiar with LoRa modules SK iM282A, measuring equipment R&S SMU200A, R&S FSQ, and parameters significantly influencing the robustness of LoRa. In the following part, measure coexistence scenarios through the evaluation of the Protection Ratio (PR) parameter depending on the value of frequency offset (Δf). From received results, compare the robustness of the LoRa signal with different configurations against different interfering Wi-Fi signals.

Introduction

Nowadays, demand for the Internet of Things (IoT) devices, like sensors of temperature, motion, controllers of light, air conditioning, or wireless networks for security purposes, is increasing. The use of Low-Power Wide-Area Networks (LPWAN) and one of the most known examples of these networks, Long Range (LoRa), has a special place in the concept of smart cities. LoRa represents a wireless communication system focused on the transfer of small size data with a low data rate (up to 50 kbps) for long-range. LoRa system fulfills several requirements of LPWAN networks thanks to their low power consumption, long-range, and small bandwidth [1]. LoRa is initially developed for the sub-GHz band. However, new LoRa-based transceivers, which enable us to realize the communication link in the 2.4 GHz Industry, Scientific and Medical (ISM) bands, have been designed. This radiofrequency (RF) band is primarily used by Wireless Local Area Networks (WLANs), between users known as Wireless-Fidelity (Wi-Fi). Nowadays, standard IEEE 802.11 is probably the most comprehensive wireless communication system in the world, and you can find Wi-Fi, a user brand of this standard almost everywhere. In the future, the massive utilization of this license-free RF band by LoRa can cause unwanted coexistence with Wi-Fi [2]. In this case, we are concerned about the problem with the sharing of the 2.4 GHz ISM band for both systems.

In general, depending on the working frequencies and channel bandwidth of coexisting wireless systems, there are three different scenarios: the co-channel coexistence scenario (CCCS), In-Band Coexistence Scenario (INCS) and Out-Band Coexistence Scenario (ONCS) or Adjacent Channel Coexistence scenario (ACCS). CCCS is occurring in the case when two systems are provided on the same carrier frequency. In this case, both LoRa and Wi-Fi have the same working frequency. On the other hand, ACCS or INCS is caused by the power of transmitter from an adjacent channel, so systems are not working on the same frequency but in the same frequency band and interfering with each other. ACCS or INCS are defined mainly by a delta of frequency or frequency offset (Δf) from the center frequency. Both scenarios are shown in figure (8-1). In this lab work, only the first two scenarios will be measured: CCCS and INCS

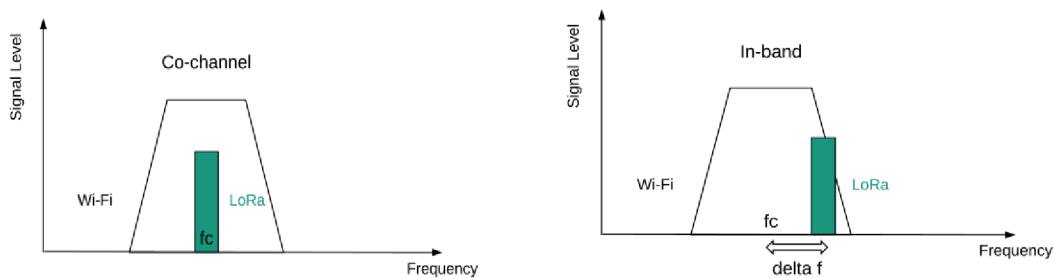

Figure 1 Co-channel and In-band coexistence scenarios

Interfered (LoRa) and interfering (Wi-Fi) signals are marked as C and I , respectively. Together with the parameters C and I , parameter, parameter Protection Ratio (PR) is defined as a difference of C and I (both in dBm) in the following equation (1):

$$PR = C - I \quad (1)$$

PR is defined as a ratio of C/I for a PER value of 10% and is expressed in dB. PER defines the ratio of incorrectly received data packets and the total number of received packets. PER is expressed in %, and the necessary requirement for reliable communication of LoRa systems is to achieve PER under 10%. LoRa-based communication with PER above 10% is considered as not reliable [3].

Used measuring equipment

- **LoRa modules SK-iM282-A**
- **Signal Analyzer R&S FSQ 8**
- **Signal Generator R&S SMU200A**
- **Notebook**
- **Wilkinson power splitter**
- **Attenuator for 2.4 GHz band**

In the next figures (2, 3) is shown a block schematic of measurement setup and connected testbed that consist of mentioned measuring devices.

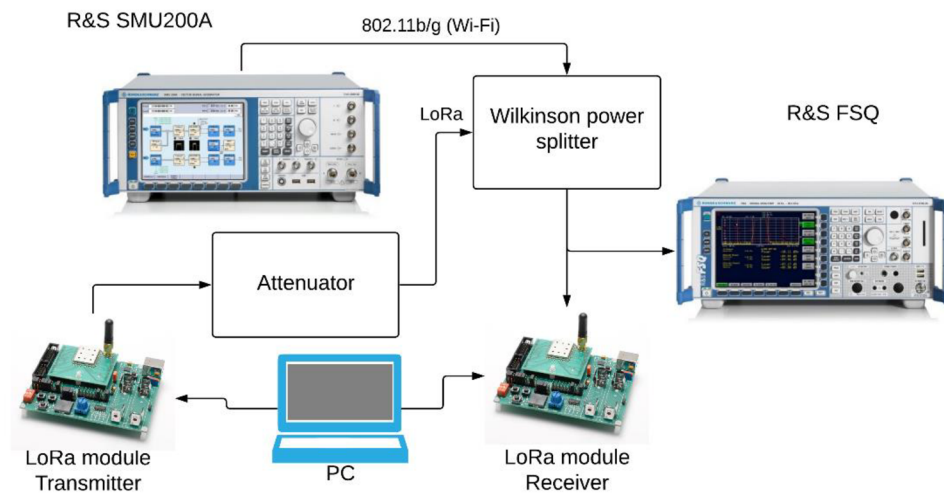

Figure 2 Block schematic of a measurement setup

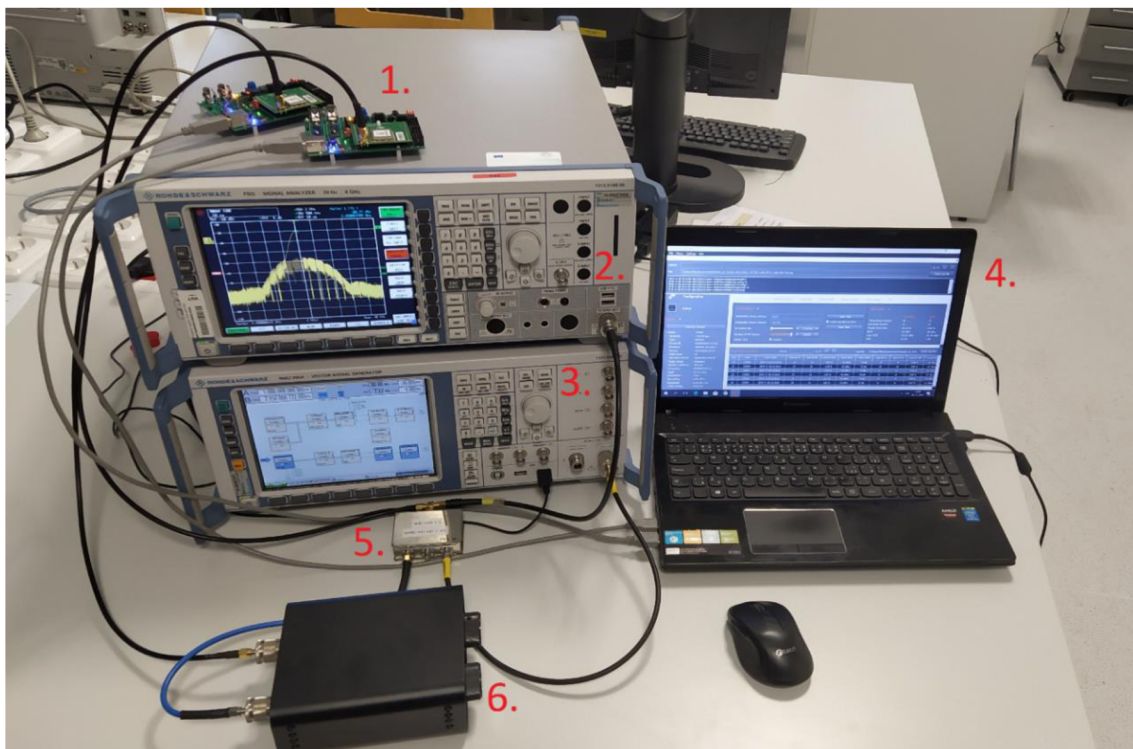

Figure 3 Measurement setup/testbed: 1. LoRa modules SK-iM282-A, 2. Signal Analyzer R&S FSQ 8, 3. Signal Generator R&S SMU200A, 4. PC, 5. Wilkinson power splitter, 6. Attenuator

Working procedure

1. Prepare the signal generator SMU200A. Set the frequency on channel B to 2 450 000 000 Hz. Choose the option to generate the desired Wi-Fi (802.11b or 802.11g) signal in the “Baseband B” window after clicking on “Configuration.” In this menu, you can also change the type of used modulation technique (CCK, PBCC, OFDM) and modulation of signal (DBPSK, BPSK, 64QAM). For the first measurement, choose 802.11b signal using CCK and DBPSK modulation. Set up an initial value of the generator power level on channel B to -95 dBm. After this, click in the window “RF-A Mod B” on the option “on.” **During the whole measurement, do not set a value higher than +5 dBm!!! It can damage the generator!**
2. Open *WiMOD LR Studio*. On the left side under “Discover Devices,” check if both modules are connected. If not, check connections and press discover devices. Select the first module (transmitter) and choose the Configuration bar. Then pick the first horizontal bar, “Radio Configuration.” **Do not change any options except the options shown in the table and set it up according to this table:**

RF Carrier Frequency	2450 000 122 Hz
Modulation	LoRa
Signal Bandwidth	LoRa BW 1600 (first configuration)/ LoRa BW 200 (second conf.)
Spreading	LoRa SF 5 (first configuration)/ LoRa SF 10 (second conf.)
Error Coding	LoRa 4/8

The basic layout of the *WiMOD LR Studio* is shown in the next figure (4).

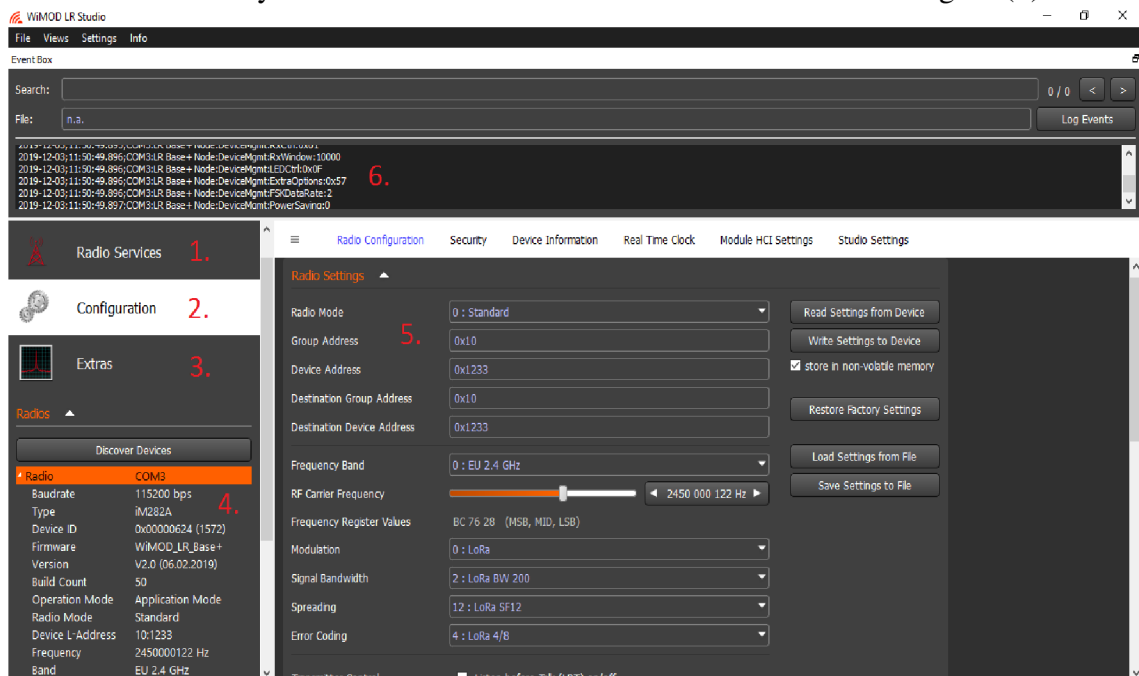

Figure 4 WiMOD LR Studio: 1. “Radio services” bar (used for test), 2. ”Configuration” bar, 3. “Extras” bar, 4. Information about connected modules, 5. “Radio configuration” (complete configuration of LoRa module), 6. “Event box.”

For the first measurement, pick the first configuration (LoRa BW 1600 and LoRa SF 5). After initial set up, confirm selected options by pressing button Write Setting to Device on the right side of the screen!!! If not, options won't get saved! Select the second module and repeat the set up of the module with the same parameter values.

3. Choose "Radio Services" vertical bar and "Radio Link Test" from a horizontal bar. After that, choose your transmitting module on the left side. The destination group address and destination device address window must have the same numbers as the receivers' addresses. RF packet size will stay on 15 Bytes. The number of packets is up to you and only defines the amount of measured packets. After this, the counter resets to zero, and measurement starts again. Option "Infinite Test" should be marked. After the start of the test, on the left side, PER in % and value of LoRa power level (downlink RSSI) will be shown. LoRa power level stays the same for the whole duration of the test (-85 dBm).
4. Press "Start Test." Slowly start to raise the value of Wi-Fi power level to the point where LoRa technology communication is not reliable so far. The value of PER should reach value around 10% for a longer period till it becomes stable. From spectral analyzer, receive the value I (Wi-Fi power level) in dBm.
5. After receiving the values of I stop the test. Repeat the fourth point for the whole frequency bandwidth until the value of $\Delta f = 10$ MHz with 2 MHz steps.
6. Calculate PR and create graph from obtained results.
7. Repeat points 1-6 for every selected configuration of LoRa and Wi-Fi.
 - Wi-Fi 802.11b using CCK and DBPSK modulation; LoRa BW = 200 kHz, LoRa SF = 10
 - Wi-Fi 802.11g using OFDM and BPSK modulation; LoRa BW = 200 kHz, LoRa SF = 10
 - Wi-Fi 802.11g using OFDM and BPSK modulation; LoRa BW = 1600 kHz, LoRa SF = 5
8. Discuss the obtained results in detail. Compare evaluated configurations from the view of LoRa resistance to interference (what configuration of LoRa parameters is more/less resistant, which Wi-Fi signal interfere LoRa more/less).

Measurement notes

- In case the communication between LoRa modules will terminate (PER = 100%), lower the value of the Wi-Fi power level. If it doesn't help, disconnect, and reconnect the devices and restart the test.
- The higher the value of PR is, the lower the power level of the interfering signal is needed, and the system is more vulnerable to interference

Conclusion

Every student must fill individual evaluation of measurement into a conclusion. Detailed comment for every point of measurement, result, and curve is needed. The conclusion should contain essential technical knowledge obtained from measurement.

References

- [1] LORA ALLIANCE. *LoRaWAN™, A technical overview of LoRa® and LoRa WAN™* [online]. 2015 [cit. 2019]. Dostupné z: <https://loralliance.org/sites/default/files/2018-04/what-is-lorawan.pdf>
- [2] WALKE, Bernhard, Stefan MANGOLD a Lars BERLEMANN. *IEEE 802 wireless systems: protocols, multi-hop mesh/relaying, performance and spectrum coexistence*. Hoboken, NJ, 2006. ISBN 04-700-1439-3.
- [3] SEMTECH. *Application Note: Wi-Fi Immunity of LoRa® at 2.4 GHz* [online]. 2017 [cit. 2019]. Dostupné z: https://semtech.my.salesforce.com/sfc/p/#E0000000JelG/a/44000000MDcO/L14bon.4HPwcyXv9fegcfcbpvLYd7Lx_aZLMzYNLIQ

APPENDIX B – Model report

Mobile Communication Systems (MSMK)

Laboratory work

Coexistence measurement between LoRa and Wi-Fi in 2.4 GHz

Used measuring equipment

- LoRa modules SK-iM282-A
- Signal Analyzer R&S FSQ 8
- Signal Generator R&S SMU200A
- Notebook
- Wilkinson power splitter
- Attenuator for 2.4 GHz band

Working procedure

- 1) In the first part, we set the required frequency on the signal generator and choose to generate 802.11b based Wi-Fi signal with the CCK modulation technique and DBPSK modulation. We set up an initial value of the generator power level on channel B to -95 dBm and switched on generating of Wi-Fi signal.
- 2) In the second point, after the opening of *WiMOD LR Studio*, we found both LoRa modules connected, so we set up all demanded parameters for both modules according to the table. For the first round of measurement, it was LoRa BW 1600 and LoRa SF 5 and checked other parameters
- 3) We jumped into the “Radio Services” vertical bar and subsection “Radio Link Test”. We set up parameters of transmission, packet size, and addresses. We made sure that the LoRa power level is set to -85 dBm measured at the input of the receiver.
- 4) We started the test and slowly raised the value of the Wi-Fi power level to point where the value of PER reached value around 10% for a longer period till it becomes stable. From the spectral analyzer, we received the value I (Wi-Fi power level) in dBm.
- 5) We repeated the test until the value of $\Delta f = 10$ MHz with 2 MHz steps. This value was set every time on the signal generator (we were moving with Wi-Fi interfering signal).

- 6) After measurement of configuration with LoRa BW 1600 and LoRa SF 5, we stopped the test and changed the configuration of both LoRa modules in *WiMOD LR Studio* to LoRa BW 200, LoRa SF 10 and checked other LoRa system parameters. We set the Wi-Fi power level again to -95 dBm and set up the required frequency.
- 7) We repeated the procedure from point 3 to 5. After this, we stopped the test and changed the setup of the interfering Wi-Fi signal. In the generator settings, we choose to generate 802.11g based signal with OFDM modulation technique and BPSK modulation. After this, we repeated other points from 3-5 and measured the value of I for the whole frequency BW of Wi-Fi signal up to 10 MHz. After this, we again changed the set-up of LoRa modules back to LoRa BW 1600 and LoRa SF 5 and repeated measurements once again.
- 8) Using equation (1), we calculated the values of PR . The value of C was all the time -85 dBm, while the value of I was changing with frequency offset, LoRa system parameters, and parameters of interfering Wi-Fi signal. We created a graph with four curves, each curve for different LoRa and Wi-Fi system parameter combinations. On the y-axis, we placed values of frequency offset while on the x-axis, we placed the calculated value of PR . We commented the results in conclusion.

Measurement results

Δf (MHz)	0	2	4	6	8	10
PR (dB)	-11	-11	-12	-16	-23	-36

Table 1 PR vs. Δf for BWLoRa = 1600 kHz and SFLoRa = 5 LoRa vs. Wi-Fi (802.11b using CCK (DBPSK))

Δf (MHz)	0	2	4	6	8	10
PR (dB)	-38	-38	-38	-40	-49	-63

Table 2 PR vs. Δf for BWLoRa = 200 kHz and SFLoRa = 10 LoRa vs. Wi-Fi (802.11b using CCK (DBPSK))

Δf (MHz)	0	2	4	6	8	10
PR (dB)	-12	-12	-12	-13	-13	-28

Table 3 PR vs. Δf for BWLoRa = 1600 kHz and SFLoRa = 5 LoRa vs. Wi-Fi (802.11g using OFDM (BPSK))

Δf (MHz)	0	2	4	6	8	10
PR (dB)	-47	-47	-47	-47	-47	-62

Table 4 PR vs. Δf for BWLoRa = 200 kHz and SFLoRa = 5 LoRa vs. Wi-Fi (802.11g using OFDM (BPSK))

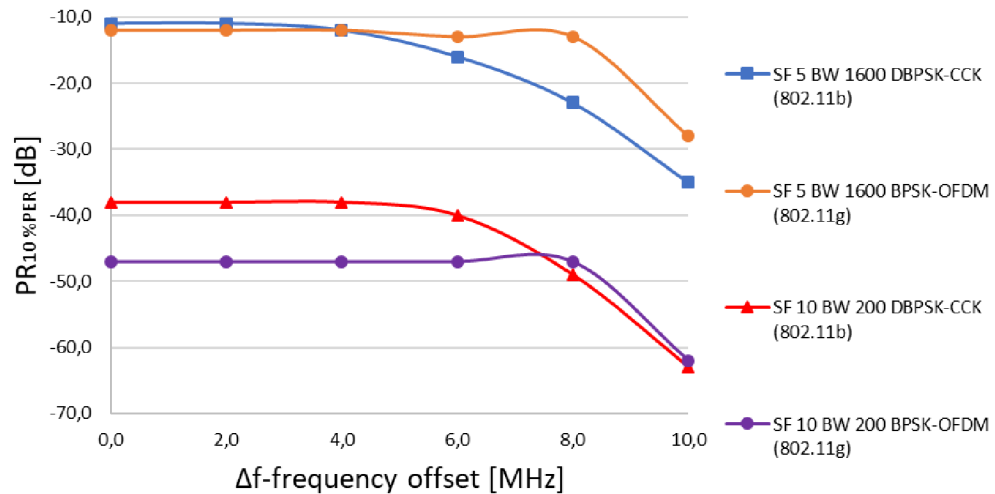

Figure 1 PR vs. Δf for different combinations of system parameters

Conclusion

From the received results, we can observe that LoRa configurations with lower SF_{LoRa} and higher BW_{LoRa} are more vulnerable to interference by Wi-Fi signals. LoRa signal with $SF_{LoRa} = 5$ and $BW_{LoRa} = 1600$ kHz reach value of PR = -11/-12 dB at the center frequency. On the other hand, LoRa configuration with smaller BW_{LoRa} and higher value of SF_{LoRa} is resistant and achieve a value of PR = -38/-47 dB. In a comparison of LoRa against interfering signals using different modulation techniques, we are able to say that robustness of LoRa vs. OFDM modulated signal is constant till the value of $\Delta f = 8$ MHz and then decreasing rapidly. In the case of the CCK signal, the value of PR is decreasing gradually from $\Delta f = 6$ MHz. An interesting fact is that in the case of LoRa with higher SF_{LoRa} and lower BW_{LoRa} against OFDM signal, LoRa achieves higher robustness against interference.

APPENDIX C – Measured data on CD