





**Department of Information Engineering**

**Business Process Modeling Notation**

Diploma thesis

Thesis supervisor: assoc. prof. Merunka Vojtech, Ph.D.

Author: Sedivy Martin

Academic year: 2009/2010

## **Declaration**

I declare that I have worked on my diploma thesis titled Business Process Modeling Notation by myself and I have used only the sources mentioned at the end of the thesis and consultancy provided by assoc. prof. Vojtech Merunka, Ph. D.

In Prague on: 13 March 2010

.....

Martin Sedivy

## **Acknowledgement**

I would like to thank assoc. prof. Merunka, V., Ph.D. for highly professional advisory services and help provided during work on my diploma thesis.

# **Business Process Modeling Notation**

# Souhrn

Tato práce se zabývá procesním řízením jako celkem se všemi jeho aspekty. Je koncipována širokospektrálně, tudíž detailně vypovídá o procesním řízení již od jeho základů. Popisuje základní vlastnosti procesů, samotné definice, ale i velice sofistikované informační technologie používané například pro procesní reengineering nebo také pro metody vyvinuté pro modelování procesů. Popisuje rozdílnost rolí jednotlivých pozic managementu i odlišný přístup ostatních sektorů v implementačním cyklu. Primárním zaměřením této práce je však modelování podnikových procesů, specifická notace a praktické využití procesního řízení.

Obecně můžeme práci rozdělit do tří hlavních částí. První část definuje termín BPM (Business Process Management – angl. řízení podnikových procesů), proces či role samotné a obecně zavádí základní principy. V první části je také vysvětlena funkce procesu v řízení a jeho základní charakteristiky, včetně vlastností procesů v obchodním prostředí. Dále byl v první části také uveden historický vývoj disciplíny řízení podnikových procesů. Vyčerpávajícím způsobem bylo zavedeno nejdůležitější názvosloví, metodologie, přístupy a standardy dostupné v rámci řízení podnikových procesů. Hlavní linií této části je obecné zavedení termínu BPM alias řízení podnikových procesů a jeho primárních atributů pro kompletní implementaci tohoto moderního přístupu do obchodního prostředí.

V druhé části práce popisuje základní postupy pro modelování podnikových procesů a vyzdvihuje nejefektivnější metody a techniky pro přístup k modelování podnikových procesů. Teorie modelování podnikových procesů a její realizace je diametrálně odlišná tematika. Praktické modelování je precizní agendou dodávající esenciální informace v celém následujícím implementačním cyklu a jeho výsledek je pak využíván ve většině vrstev obchodní struktury. Není tedy vhodné tuto disciplínu

podcenit. Právě proto se také druhá část zabývá standardy pro modelování podnikových procesů a následně specifickou notací, která se svými vlastnostmi katapultovala na téměř dominantní pozici. Práce tak obsahuje vyčerpávající definice a deskripci nejrozšířenější notace pro modelování podnikových procesů BPMN (Business Process Management Notation).

V poslední části je v této odborné práci prakticky demonstrována síla a efektivita nejrozšířenější notace pro modelování podnikových procesů. Nejdříve je stručným způsobem zhodnocena situace na poli dostupných nástrojů pro modelování ve zmíněné notaci a následně je pak provedena případová studie. Tato případová studie z oblasti elektronické komerce simuluje implementaci konečného řešení. Proces začíná objednávkou klienta a končí samotným předáním.

## **Klíčová slova**

Proces, role, řízení, BPM, BPMN, modelování, software

# Summary

This paper deals with process management as a whole with all its aspects. It is designed as broad-spectrum thesis, thus speaks about details of the process management since its foundation. Describes the basic properties of processes, by definition, but also very sophisticated information technology systems used for example for process reengineering but also for methods developed for business process modeling. It also describes the diversity of roles within management positions and a different approach in other sectors of the implementation cycle. The primary focus of this paper is business process modeling, specific notation and the practical application of process management.

Generally, thesis can be divided into three main parts. The first part defines the term BPM (Business Process Management), process and the role itself, and generally establishes the basic principles. In the first part is also explained the function of process management and its fundamental characteristics, including characteristics of the processes in the business environment. In the first part was also given historical development of business process management. Exhaustively was introduced important terminology, methodologies, approaches and standards available in the area of business processes. The main line of this section is a general introduction of the term BPM alias business process management and its primary attributes for a complete implementation of this modern approach to the business environment.

The second part describes the basic procedures for modeling of business processes and highlights the most effective methods and techniques for approach to business process modeling. Theory of business process modeling and its implementation are vastly different topics. Practical modeling is a precise agenda, delivering essential information in its subsequent implementation cycle, and the result is



then used in most of layers of commercial structures. It is therefore not appropriate to underestimate this discipline. That is why the second part is dealing with standards for modeling of business processes and consequently a specific notation, which was catapulted by its properties to nearly dominant position. The paper thus provides a comprehensive definition and description of the most widespread notation for business process modeling, BPMN (Business Process Management Notation).

In the last part of this diploma thesis is practically demonstrated efficiency of the notation for business process modeling. First of all, there is a brief way to assess the situation in the field of modeling tools available for the notation, and then conducted a case study. This case study on electronic commerce simulates the implementation of the final solution. The process begins with customer order and ends by delivery itself.

## **Keywords**

Process, role, management, BPM, BPMN, modeling, software

# Content

<b>1</b>	<b>INTRODUCTION .....</b>	<b>- 8 -</b>
<b>2</b>	<b>OBJECTIVES OF THESIS AND METHODOLOGY.....</b>	<b>- 11 -</b>
2.1	OBJECTIVES OF THESIS.....	- 11 -
2.2	METHODOLOGY.....	- 12 -
<b>I.</b>	<b>BACKGROUND.....</b>	<b>- 13 -</b>
<b>3</b>	<b>BUSINESS PROCESS MANAGEMENT.....</b>	<b>- 14 -</b>
3.1	PROCESS AND ROLES DEFINITIONS .....	- 14 -
3.2	BUSINESS PROCESS MODEL .....	- 19 -
3.3	BUSINESS PROCESS MODELING METHODS .....	- 20 -
3.4	HISTORY OF BUSINESS PROCESS MANAGEMENT .....	- 25 -
3.5	FUNCTIONAL VS. PROCESS MANAGEMENT .....	- 26 -
3.6	BUSINESS PROCESS REENGINEERING.....	- 28 -
3.7	REENGINEERING PRINCIPLES.....	- 29 -
3.8	REENGINEERING METHODOLOGIES .....	- 29 -
3.9	CONTINUOUS MODEL-DRIVEN ENGINEERING .....	- 31 -
<b>4</b>	<b>BUSINESS PROCESS MODELING NOTATION .....</b>	<b>- 33 -</b>
4.1	OBJECT MANAGEMENT GROUP .....	- 33 -
4.2	BRIEF INTRODUCTION TO BPMN.....	- 35 -
4.3	BPMN AND PROCESSES .....	- 37 -
4.4	BPMN MAPPINGS .....	- 40 -
4.5	BPMN CORE ELEMENTS SET .....	- 42 -
4.6	EXTENDED SET OF BPMN CORE ELEMENTS.....	- 49 -

4.7	EXTENDED GATEWAYS BEHAVIOUR.....	- 55 -
4.8	FLOW OBJECT CONNECTION RULES .....	- 59 -
<b>II.</b>	<b>PROJECT .....</b>	<b>- 62 -</b>
<b>5</b>	<b>CASE STUDY .....</b>	<b>- 63 -</b>
5.1	INTRODUCTION .....	- 63 -
5.2	BPMN FREE TOOLS .....	- 64 -
5.3	CASE STUDY – IMPLEMENTATION OF E-COMMERCE SOLUTION .....	- 69 -
<b>6</b>	<b>CONCLUSIONS.....</b>	<b>- 82 -</b>
<b>7</b>	<b>BIBLIOGRAPHY .....</b>	<b>- 84 -</b>
<b>III.</b>	<b>APPENDIX.....</b>	<b>- 85 -</b>
<b>8</b>	<b>SUPPLEMENTS.....</b>	<b>- 86 -</b>
8.1	LIST OF TABLES.....	- 86 -
8.2	LIST OF IMAGES .....	- 86 -

# 1 Introduction

Since there is a massive competition within either global or local markets the need for change and dynamic behaviour of enterprises became incredibly important. Without change and embracement of new approaches it would lead directly to a dead end. The need of change always follow the request of business performance improvement. Business process management (hereinafter BPM) approach is a business discipline and function that uses business practices, techniques and methods to create and improve business processes, thus enterprise business performance. From this general definition it is mandatory of process improvement discipline to mention activities and approaches that have been already tested and successfully implemented including process reengineering, TQM<sup>1</sup> or Six Sigma quality methods. One could hit the terms of outsourcing and lean manufacturing within business environment as well. Those can be considered as a part of BPM because those methods already adopted the BPM in practice and upgraded it to specific level. Thus, from an extremely general perspective, BPM has distinguishing definition at the point of view that ordinary business management is completely replaced by different approach to management. Only that way the improvement of business performance can be delivered.

On the other hand the term BPM has been placed onto the front pages of the business and technology literature for far more specific reasons. If manual or even automated, companies have learned that the partial business process improvement methods and techniques they have tried throughout their organizations did not produce breakout results. If manufacturing division uses one approach, and marketing department uses different techniques, without talking to one another it doesn't mean it is

---

<sup>1</sup> Total quality management

a proper case of process-managed enterprise. That kind of enterprise that produces outstanding and sustainable business results. The real point of this paradigm is within global overview for business workflow inside enterprise and often behind its boundaries. Within BPM whole business transaction is controlled from the very beginning to an absolute finish, hence delivery.

BPM is in its contemporary context modern approach to be used in segments built by appropriate process-related business disciplines that are used to drive business performance improvements, not just across the departments in a single company, but also at cross industry environment. The primary objective of this approach is actually transform regular methods of driving business to those generating improvement, thus in this case process-related ones. This approach has become practical as a result of the new category of BPM software systems, which also demonstrate how desperately is this method influenced by information technology. Today technology package is organized under the application servers, software that is part of a distributed application with three layers as the user interface, the business logic, and the back end databases. Those servers are often labeled as internet servers, for their primary use by connecting business systems such as ERP<sup>2</sup> and newer internet-oriented applications. BPM servers add yet another layer to this already complex technology stack.

The situation could be seen as similar to one of the emergence of database systems a couple of decades ago. What are known as hierarchical and networked database systems which used pointers and links to keep data elements tied together logically although their physical storage was in a different form. They worked, up to a point but when the links were broken, business information systems failed and had to be recovered by reloading the databases. That was certainly no way to run a company's business-critical information systems. Present day disaster recovery managers would strongly agree. So there was an innovation that came along. An innovation while instead of links and pointers, a researchers used the mathematics of relational algebra as the

---

<sup>2</sup> Enterprise Resource Planning

foundation for a new kind of database system that removed the need of complex links and pointers. The relational database management system (DBMS) was so solid and reliable that a whole new kind of applications called enterprise resource planning (ERP) systems emerged. And such systems are now the foundation for automation in large and mid-size business companies across the planet. We can still see an extreme progress e.g. when it comes to Oracle solutions within relational databases. On the other hand there will be significant pressure on transition from relational model to object oriented databases e.g. GemStone solutions. The same level of innovation is needed for business process management if wanted to get beyond the already complex technology stack and the additional complexity BPM introduces. That innovation can be called the business process management system (BPMS).

With BPMS can be achieved a simplification of work. It does not add yet another layer to the already complex technology package, it just simplify using of the existing technology. Its core capabilities are built from the ground around business processes, not technology processes. Thus, the tools built above the BPMS can be designed for business analysts, not just technologists. With BPM servers, the business process is torn apart and stored among the various technologies. With the BPMS, the business process remains whole, and overcomes the fragility inherent in BPM servers that is similar to the fragility that broke the hierarchical and networked database models.

Business processes are active in long period, and thus, have to be persistent. There is a need of ability to switch off the system and switch it back on again without any damage. And processes do not just execute, it is needed to manage them as they evolve [8]. A BPMS provides a clean model for the stored processes, so that tools can be built above for managing them. The BPMS provides the process-oriented architecture needed to build a process-managed, real-time enterprise.

## 2 Objectives of thesis and methodology

### 2.1 Objectives of thesis

First but not primary objective of this diploma thesis is to accurately define and describe the term of business process management which is more or less involved in the background of almost all bigger companies in this spell. The importance of the term business process management alone is being horribly misunderstood, thus the precious knowledge base is either needed or requested. The objective of this paper is not to somehow elevate the importance of process-related firms, but rather to provide objective overview above this discipline. Business process management is all the time shifting to new stages, hence this paper describes those consolidated facts.

Second objective of this paper is to provide potential candidates with bridge connection of business process management approach and its practical usage within modeling of business processes following by business process systems development. There is a proper connection involved within this thesis which is concerning business process modeling and the business process modeling notation. Business process modeling notation is one of the most important tools when it comes to modeling of business processes. The brief definition within this thesis is not completely aspiring for any possible substitution of business process modeling notation official specification. In the contrary it is essential to describe basic elements of the notation in order to depict the concept of process-based modeling.

Finally, the primary objective of this diploma thesis is the case study which is supposed to simulate real situation within electronic commerce industry and also to bring potential candidates a bit closer to successful adoption of knowledge base for business process modeling notation. The case study itself is clearly defined to provide

users with information concerning business behaviour and apply that behaviour to real environment. In the other words there is potential business situation shown on the business process diagram where it was decided to use business process notation as a standard.

## 2.2 Methodology

Methodology of fulfilling of our objectives is very simple concerning this paper. As is mentioned above, those objectives involving business process management approach, business process modeling techniques and particular notation result in one bigger output. It is mandatory to conduct a research on available literature and also on practical situation within business environment.

The business process diagram is absolutely essential element within the business process modeling. Thus, to produce well designed output it is a need to get acquainted with particular area of business process management at least and business process modeling as a whole. For this procedure we involve several important sources in order to produce trustful output.

For our primary objective which is to build up particular business process diagram we have to decide which tool to use. This decision criterion is supported only by free availability within market. Thus this objective is not depended on which tool is about to be decided to use for, but on the fact that there is a need to produce proper business process diagram. Such business process diagram is to be modeled within by high quality tool using and standardized business process modeling notation. To design up such output it is mandatory to cope with business process management paradigma, also to understand either business process modeling or particular notation and follow the primary concept of such solution.



# I. Background

## 3 Business process management

### 3.1 Process and roles definitions

#### 3.1.1 Process

The definition of process is not well known in general and certainly the concept is not precisely and correctly used. Many of line managers use this term very often, without realizing the substance of the matter. What does the concept of process mean? Where can we meet with the process? Many employees meet with the concept of the process in the direct binding to managers but they often use this term for their own presentation of the modern approach to management, without being able to explain the concept. Whether it's conference, meeting or brainstorming, we can find the concept of the processes all over those organisational items. But what does process really mean. By ICT<sup>3</sup> astute experts focused on operating systems is the process represented as a executed and running program by operating system, as defined [4]. This idea is obviously not an instance of business process, but a general description describes it very accurately. In business terminology by this point it could be translated as staff processed series of steps to satisfy the customer.

If it is abstracted from the general information processes and the focus moves to the general pattern in normal company, we discover the environment in which it is possible for process to meet fully all of us. E.g. when we decide to buy a car. The process begins with entry into the sales center of selected brand and ends with smile on customer's face on the way home by a new car. In this case, the process means the

---

<sup>3</sup> Information and communications technology

procedure of processing the customer's requirements, designed to leave in a new car. Individual parts of the process are those steps that must execute sales manager, so we can happily leave by a new car. This is an example of "business process". Another example of a business process may be building up a family house, delivery of ordered goods from electronic shop, production of web sites, shopping in a supermarket, appliance repair, lunch in a restaurant and so on.

*Definition [5]: Business process is a summary of activities, a summary of transforming inputs to outputs for a set of other people or processes, utilizing to other people and tools.*

### 3.1.2 Process attributes

Process from latin *processio* stands for progression, procedure, procession, processions. Processes are generally divided into stochastic (random) and deterministic (causal), and planned – a pattern of this process is influenced by man. Business processes are planned and perceived as an abstract way of working. In general, each process is somehow stochastic, because not even in a corporate environment with the narrowest limits we can guarantee its predictable procedure and flow. Thus, controlling of a process is an idealization of a very advantageous way for practical purposes. Process itself can be characterized by the following attributes [6]:

- Purpose – what and why to be achieved
- Construction – how to achieve the objectives
- Rationale – what is the reason behind the process
- Roles – which roles are real, which responsibilities are assigned, which stimulus is real and what are the criterias for the roles
- Order – which phases or sequences are used

*Definition [6]: A process is an activity which takes place over time and which has a precise aim regarding the result to be achieved. The concept of a process is hierarchical which means that a process may consist of a partially ordered set of subprocesses.*

### 3.1.3 Roles

Role of workers (work teams, organizational units, etc.) within enterprise in process management is understood as their share of the resulting value created by different processes. From functional management with the organizational structure it varies in complete change of approach and thinking. Management has usually an idea how to realize the potential of using business process management and is looking for specialists who would carry out these ideas. Objective of definition of roles within management of business processes is the declaration of competence and responsibilities at the same time, thus involving specialists in defined roles. Important motivating effect, so-called stimulus, is the withdrawal of a worker agenda of the current system, which after the transformation will be assigned to him. Only when there is a complete definition and description of the roles for the selected business process and any role in the process is effectively defined, may be running a pilot project that will own the implementation-defined attributes and procedures. Roles can be defined as the lowest and the middle level of the enterprise management as well as at the highest level of corporate governance.

In terms of the organizational structure of management, senior manager enters a request to change the process and execution for process owner using an update of strategy. Parallel to the operational plan requires the responsible manager to process assignment, specifying the performance of the process or its parts of aims to meet. Subsequently, the owner of the process requires managers to learn how to process work.

#### 3.1.3.1 Senior manager

Senior manager is manager situated within first line of management with highest importance. The role can be assigned to top manager, or another member of the top management. He is responsible for [5]:

- Enforcement of BPM at the enterprise
- Defining strategic priorities

- Disintegration of the strategic objectives for the level of assignment of changes for the individual processes
- Evaluation of process owner and BPM<sup>4</sup> animator

#### 3.1.3.2 Line manager

Line manager is a manager of the second level management who is responsible for command and control of individual threads from his professional focus. This executive manager is usually called according to organizational structure. As the name implies it is still position more management than process approach focused within regular non BPM organisations.

#### 3.1.3.3 Process owner

Process owner is a role that can be charged as one from line managers, as well as anyone out of regular governance structure. This role is responsible for the setting of the process to perform the function in detail and resulting revenues from the strategy and also for ongoing performance improvement of the process [5]. This is a critical part in the management of business processes. What already worked for this role was to get entrusted line managers, who directly manages a key part of the process and therefore has a real understanding of the process and the corresponding position in the hierarchical organizational structure. Owner of the process creates a process team around himself that is composed from key personnel for the process to cover the entire process knowledge.

#### 3.1.3.4 Animator

Animator is a role that the larger companies often set up as a separate posts, in smaller companies it can be assigned directly through a member of senior management or staff

---

<sup>4</sup> Business Process Management

as appropriate for the organization and management, quality management and IT<sup>5</sup>. This role is fully responsible for [5]:

- Development of management systems and promotion of business process management
- Continuous performance improvement of business processes
- Coordination of changes in enterprise
- Development of knowledge base in the area of business process management

#### 3.1.3.5 Business consultant

Business consultants can work in two positions – as internal consultants who supply the necessary methodology and technology, or as in-house animators and tutors, who activate process teams to changes, or possibly provide training for selected personnel. Sometimes acting as representatives of the owners of processes.

#### 3.1.3.6 Architect

Architect is a person that looks at the various processes in the organization and puts together architectures for processes as well as important business rules. Works to resolve the inevitable differences that crop up between the business process analysts and business units. This role may be associated with the role of an animator or one of the analysts. Architect is responsible for consistent management of the system and methodology for the implementation of process management.

#### 3.1.4 Process function in management

At the turn of the nineties it became clear that an outdated management style of companies is in the new modern and highly competitive conditions unsatisfactory. The company was no longer effectively managed by the statically-defined hierarchical structures, where each staff member place is fixed, responsibilities pre-defined and the

---

<sup>5</sup> Information Technology

equal competence for it. Such a management style presupposes just static structure of activities and continuous follow up, e.g. precisely defined sequence of constant activity. Flexibility is in the case of constant activity unexpected and substitutability of workers difficult. Separate domain of problems is then the motivation of staff and their creative approach. Organizations to meet the demands of process control require [1]:

- Change of the basic concept of the nature and of its functioning
- Eliminate the organizational structure from corporate culture as a tightly defined structure, activities and relationships
- Eliminate attributes resulting from the above-mentioned structure – the powers, responsibilities, communication procedures, remuneration, promotion, etc.

In place of a statically defined structure is the foundation of organizations like the idea of process-driven business a set of activities that takes one or more inputs and generates output which is highly valuable entity for clients. Processes are therefore understood just for one assigned purpose. Figuratively speaking, the transformation of inputs to outputs, not to carry out activities and always in relation to the customer.

*Definition [1]: Processes and their relationships, therefore form the basis of the organization.*

## 3.2 Business process model

There are many variable standards and approaches for process modeling resulting from different ways which place different emphasis on different aspects. Some of them are influenced by the information systems, some by technologies, others are trying to target as a description of the process with the human factor. But all these standards and approaches have common basic elements. The basic elements of a business process model - process, activity, initiative, bond, continuity.

*Definition [5]: The process is always modeled as a structure of activities.*

Each activity can be broadly defined as a process. Whether it will be described depends on the clarity of described model and modeling tools used (tools – sometimes there is a need of tools to be combined) system limitations, etc. In essence, therefore description of the process do not depend on its content page, but on the circumstances which arise as a result of implementation of the process. Individual action is not carried at random, but on the initiative of pre-defined reasons. In terms of process, the stimulus may be external or internal reality [5]. External stimuli are called events. Internal stimuli are then defined as states of the process. Different approaches model the states of processes such as the various separate elements of the description of the processes (semi-step event, interval work). Activities are sorted in the mutual continuity. They create the following set of activities (processes) defined as a structure and continuity of processes is described using constraints. Bindings define different way of working in the process. They are defining the types of cross ties – knots, junctions, gates.

### 3.3 Business process modeling methods

Since the methodology and process modeling techniques are still in development and that the issue is constantly in motion and especially at an early age, it occurs in a lot of process control methods that they aspire for the potentially effective use. The aim of this work is not to enumerate all of these methods but to depict the most valuable, what is in the business process management approach to corporate governance now considered as a effective background for solution.

#### 3.3.1 ARIS<sup>6</sup> methodology

This method was developed by prof. Dr. August-Wilhelm Scheer, who is professor at the University of Saarbrücken, as the reference architecture of an information system. The method consists of the following perspectives – the organization as a corporate

---

<sup>6</sup> Architecture of Integrated Information Systems



look, functionality from the perspective of information system and information management. This method does not define any specific action, but rather provides a range of views of modeling of various aspects [5]. Such aspects of existence and functioning of the enterprise. Operation of the enterprise is meant by the processes flow. It is eventually enabling interdependent analysis and system design of the enterprise.

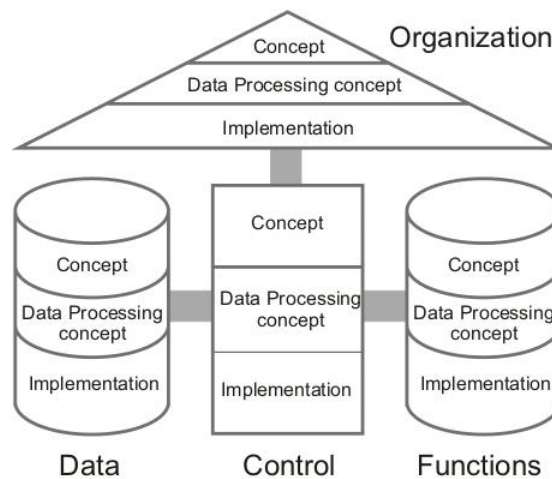

**Image 1 – ARIS model (aris.com 2010)**

Organizational perspective describes the staff and organizational units, the composition of these units and links between them. The data view is made up of states and events, where both options are represented by the data. Functional view consists of functions and their mutual relations. Process view as a central view describes the relationships between different views. Individual views are closely linked. According to ARIS concept is the processes workflow handled in several levels, interacting and inter-related [5]:

- Process design
- Process application
- Process workflow
- Process management

ARIS tools and the main use of ARIS is to design business processes. Establishment and management of business processes is also important aspect of these instruments.

ARIS concept is linked primarily with computer tools to help modeling of tools for creating modeling platform. ARIS provides in a summary the products of four basic platforms and 105 different types of models. Different models use different technologies, so the internet, viewing data objects, the integration of multimedia objects, simulation of the processes, or methods of classical performance management balanced as scorecard are used.

- Modeling platform
  - ARIS Webdesigner, ARIS toolset, ARIS EasyDesign, ARIS Simulation, ARIS BSC (Balanced scorecard), ARIS Web Publisher, Process Comp@ss
- Implementation platform
  - ARIS for mySAP, ARIS UML Designer, ARIS P2A (Processes to application), ARIS for Intershop entity, ARIS Integrator for Vitria, ARIS for Hypewave, MDA (Model Driven Architecture) business transformer, HR<sup>7</sup> link
- Controlling
  - ARIS Process Cost Analyzer, ARIS Process performance Manager

### 3.3.2 Business system planning

This method was created in 1984 by IBM<sup>8</sup>, while it was published in 1981 at first. Method was developed specifically for the analysis and design of information architecture within the implementation of its information system. The aim was to create an information architecture that would support all ongoing processes, respect the organizational structure, meet all short term but also long-term IT needs of organizations. In fact, it may be used in a very broad spectrum, such as the transformation of global strategy into the strategy of information and audit of information support etc. Basic methodological value of the BSP is in the most fundamental principles of drawing attention to the basic context of the organization,

---

<sup>7</sup> Human resources

<sup>8</sup> International Business Machines Corp.

such as the need for information analysis. Precisely defined procedure that ensures sufficient attention to the right things at the right time and order is also very important. Finally, the techniques to support key stages of the procedure (technical matrix cluster analysis, information technology crosses) play huge role within this methodology.

*Definition [IBM, 2010]: If the information systems of organizations are designed as a separate units, irrespective of the data required and used in other systems and subsystems, this leads ultimately to a non-flexible and non-integrated ERP<sup>9</sup> system.*

BSP basic idea is that the data is a common resource. BSP uses data structure as a basis for planning of IS<sup>10</sup>. Accordingly, if once defined data for the ongoing processes in the organization, the resulting IS is stable, until any damage is caused within structure of these processes. BSP assumes the top-down design of IS and implementation within the top-down by parts. Top-down approach is given by possible definition of basic elements at first and it is formulated into a general model and subsequently its internal structure. Process begins by obtaining information from senior management, which appears as the highest activity level. The important part is the analysis of the organization, which consists from the definition of business processes and data classes, and analysis of information support. Finally, progress plan and the presentation of results is defined. Following steps roughly describe BSP process [5]:

1. Obtain authorization for the study
2. Assemble the study team
3. Define the data classes
4. Define the business processes
5. Use data classes and business processes, define the information architecture
6. Compare architecture with the present systems and identify missing and/or needed systems

---

<sup>9</sup> Enterprise Resource Planning

<sup>10</sup> Information System

7. Interview senior management to ensure the architecture is correct and identify any problems
8. Establish priorities for each of the major systems contained in the architecture
9. Prepare the final study report and present it to top management
10. If approved, initiate the construction of the architecture

### 3.3.3 ISAC

Worth noting is certainly methodology ISAC (Information System Work and Analysis of Change), which is focused on the development of IS in particular in its early stages. The first version was established in Sweden in 1971. The main subject of this method is especially the real system. The procedure defined by this method has 5 phases - analysis of requirements for change, study activities, information analysis, system design, edition of environment. The method is oriented on finding the causes of user problems. Graphs are very similar to data flow diagrams.

### 3.3.4 DEMO

Essentials Dynamic Modeling of Organizations is a method of modeling business processes. But is also used for process reengineering. Its principal author is a prof. John Dietz from Technical University of Delft in the Netherlands [5]. DEMO is a non-traditional view, where instead of the network activities, is business process seen as a network of communication. A key benefit is the shift from traditional analysis of the enterprise to analysis of how the business actually operates. The method describes itself as an organizational engineering and is based on the ontological definition of system. In this context also refers to the white box model.

The organization consists of individuals or entities, and they carry two types of acts. Production acts may be material or immaterial and subjects fulfill organizational missions within those acts. Coordination acts enter into reciprocal commitments and coordinate the implementation of production acts. Due to the implementation of the act

of production was introduced so-called DEMO role player and a subject fulfilling this role is called the actor. The result of the production act is a production fact. Actor who will start the transaction is called the initiator, the following actors, which then carry out the transaction is executor. The concept of production acts and actors leads to distinguish between the three levels of abstraction, as described: essential view, info view, document view.

*Definition [5]: Business process is defined as a structure of causally related transactions.*

### 3.4 History of business process management

As BPM stands for Business Process Management loosely interpreted as managing everything what is connected with business processes and procedures. BPM is a revolutionary approach to the workflow management within company. Previously was this acronym used for business process modeling or business performance management. At present, we encounter the acronym BPM 2.0, which is a new generation of process control. This new update of older BPM integrated whole management of the entire life cycle of the business (from strategy and processes to IT), not only methodologically, but also physically in the IS. Technologically it is built mostly on SOA<sup>11</sup>. According to IBM, SOA represents the architectural style based on composing of applications from independent components. By folding of these services is then possible to establish this modern style of a business application.

Procedures in force two hundred years ago where the main benefit was the division of production into the simplest tasks has got outdated and were gradually replaced. The need for changes in corporate governance was inevitable and arose from the objective facts. In post-industrial era it was customer who become a criterion of

---

<sup>11</sup> Service-oriented architecture

focus. At that time, the work of Adam Smith<sup>12</sup> become an important milestone in the development of socio-economic system. Division of labor operations, allowing a narrow specialization of workers, resulted in rapid growth of skills and therefore changes in the organization of firms, relations between them and ultimately in the reorganization of the entire market.

While in earlier times every company should have many customers, and the general interest of the population could be met, now the opposite is true and tough competition for every customer is a daily occurrence. The market is saturated and the customer becomes a leading element to which the company must focus the most. Today, the customer can choose from many products and the decision to buy this or that often occurs right at the shelves in supermarkets. This leads to a substantial number of companies modifying products for more attractive offers and thereby to produce a complex division of labor. Of course, intense competition requires minimizing costs and production at the lowest prices. It has resulted in continuous adaptation to market and continuous transformation of production. Now these are best characteristics for adoption of production managed by processes and narrow specialization of services.

### 3.5 Functional vs. process management

Why is the concept of process management in organization today, how important is to reflect it in process models, how are changes reflected in IS or how is technology evolving. This is all due to the need of change. As well as external environmental changes cause internal changes in the organism, we describe a similar situation when it comes to the business company. Turbulent market environment, knowledge society and globalization cause changes within the business, so a new target with a new different ways of achievement is required. Mode of changes, alias the transition from functional to process management is expressed in the following structure [5]:

---

<sup>12</sup> Scottish moral philosopher and a pioneer of political economics

- 1. Functional management is based on the principle of division of labor: the process is broken into various activities.**
2. The aim of production is maximum production at minimal cost
3. The greater the specialization of workers, the better the achieved quality and higher quantity
4. Emphasis is placed on the division of labor, because it increases productivity
5. Attempts of production maximization result in mass production
6. The market is gradually saturating, growing competition
7. The requirement is flexible production in order to meet the individual needs of the customer
8. Target of production varies: it is the maximum added value for the customer with the lowest possible cost
9. The goal of the processes: the more integrated process, the progress is faster and better customer satisfaction
- 10. Process management is based on the principle of work integration: build from the various activities as efficient as possible ongoing process**

In connection with the transition to the business process management is often mentioned as so-called third wave business processes [5]. The first wave, which took place in the first quarter of the twentieth century, is known for making manuals for working methods and procedures. The second wave took place at the end of the 20th century. Process management, in essence, influenced most of the corporate IS. Implementation of process management was associated with an overall review of the processes and their management. The third wave should offer the creation of business processes "on the fly". The companies are always being influenced by three forces: customers, competition, change – sometimes referred to 3C. Processes must be constantly adapting to these forces. The third wave is the synthesis and extension of all these methods and technologies into a single whole, so as to perfectly support the management system.

## 3.6 Business process reengineering

Business process reengineering (hereinafter BPR) as approach for effective improvement of the processes is completely different from the continuous process improvement. In the most extreme view of BPR assumes that existing business processes are entirely unsatisfactory and need to be fundamentally changed [5]. This aspect allows the designer complete detachment from the current state and to focus on the process completely new. Reengineering approach starts by defining a range of forthcoming projects. Continues by analysis of needs and options, based on this analysis it is possible to create a vision of future processes, or create a new set of processes. This system is also need to be linked so that it is possible to plan the transitions between processes in the system. On the basis of all these steps, changes can be implemented and new processes within the system introduced.

### 3.6.1 Improvement and innovation

The level of change is compared to continuous improvement, radical. Often, the term indicates that in the contrary to improvement over existing processes, process reengineering is building from scratch [5]. But it also means more time consuming. Another difference compared to continuous improvement is participation, which is for reengineering the top-down but continuous improvement starts at the lowest level of organization. An important aspect is the risk of changes implementation. Where continuous improvement of business processes causes the risk changes in small to medium, whereas in the process of radical reengineering the risk is high. This means that designers should focus on properly conducted reengineering cycle. It is then possible to evaluate whether successful or unsuccessful.



### 3.7 Reengineering principles

Principles of reengineering of business processes were defined during the nineties, which was basically the best period of reengineering, as mentioned [5]. That time were then established the basic principles of practice and analysis of obtained results of reengineering. Ranked among the base was that companies should focus in terms of external environment on the targeted customers and provide increased value. In terms of the internal environment this would mean the involvement of a maximum capacity of human potential in the activities of supplying customers with value and the human potential of training gradually by e.g. creation of a creative work environment and engagement of the greatest motivational effect. From the processes should be removed activities not bringing any business value, where their place should focus on the output value and then continuous working with it. The resulting value should be taken as a priority before the managerial control. An important factor is the replacement of line managers and work teams everywhere where it is possible to give employees full responsibility for themselves. One of the most important principles is to keep the number of key processes to a minimum around 12 and that system of processes build so that we achieve the shortest feedback.

### 3.8 Reengineering methodologies

#### 3.8.1 Methodology by Hammer and Champy

The above-named are classics in business reengineering and define it as the fundamental thinking and radical reconstruction of key business processes. The main problems they see as a lack of management skills and unclear objectives. The basic process reengineering project could be characterized by Hammer and Champy [5] as follows – introduction to reengineering, identification of business processes, selection of processes for reengineering, learning selected processes, redesign of selected processes and implementing new business processes.

### 3.8.2 Methodology by T. Davenport

In this methodology, the main factor in reengineering is information technology, which play a key role for its innovation potential. Further it highlights the organizational and personnel issues. In terms of management of changes it tends to more functional trend, e.g. planning, monitoring, etc. This methodology has six steps - setting the vision and objectives, identification of processes, learning and measurement of processes, applications, information technology, prototyping (creation of functional prototypes) processes and subsequent implementation.

### 3.8.3 Methodology by Manganeli and Klein

This methodology recommends to focus on processes directly supporting the strategic goals of the organization and the requirements of their customers [5]. As the main obstacles is seen the impact on the organization, time, cost and risks, e.g. the classical critical factors of organizational projects. The methodology starts with the preparation of the project, then continues by identification of processes, determination of visions, technical and personnel redesign and ends by transformation, then by implementation of reconstructed processes.

### 3.8.4 Other methods

Another successful methodology may be called Kodak, specifically user-oriented, or DoD which is focusing on governance. Also professor Scheer's ARIS method with the academic foundation and an emphasis on the development of IS. PPP method or DEMO accentuating the formal modeling of processes and companies is possible to stress in this moment as well..

### 3.9 Continuous model-driven engineering

Agility has become an increasing necessity when it comes to business critical issues where software systems drive and coordinate company to its product planning, production, marketing and sales as well as the connection to suppliers and customers. Such systems are gaining strategic importance and at the same time they must be continuously updated and adapted to meet ever changing market conditions. On the one hand software production and maintenance become increasingly delegated to third parties. On the other hand companies feel growing need to control their own business. So how do companies bridge this gap.

Model-driven design moves the focus from programming activities to the modeling level but still remains in IT segment [7]. Even when it comes to platform independent level those usually used UML based model driven designs provide focus in different technical issues and mastering of such a technology requires a special type of skills, IT knowledge and good sense of dealing with abstraction.

Service-oriented architecture tries to get over regular programming problems by abandoning development of complex applications or service-like artifacts programmed in the small. This supports agility but addresses neither the problem of development or management of evolution.

Process modeling provides a formal basis for application and business analysts and allow them to express their intents unambiguously. This works quite well in cases when analyst fully knows what he needs and has a particular skill to enable him to express the problem within business process modeling notation. Otherwise, the visual nature of diagrams can easily suggest wrong safety. Anyway, they are still taken as better forms of documentation to be correctly interpreted by IT personnel.

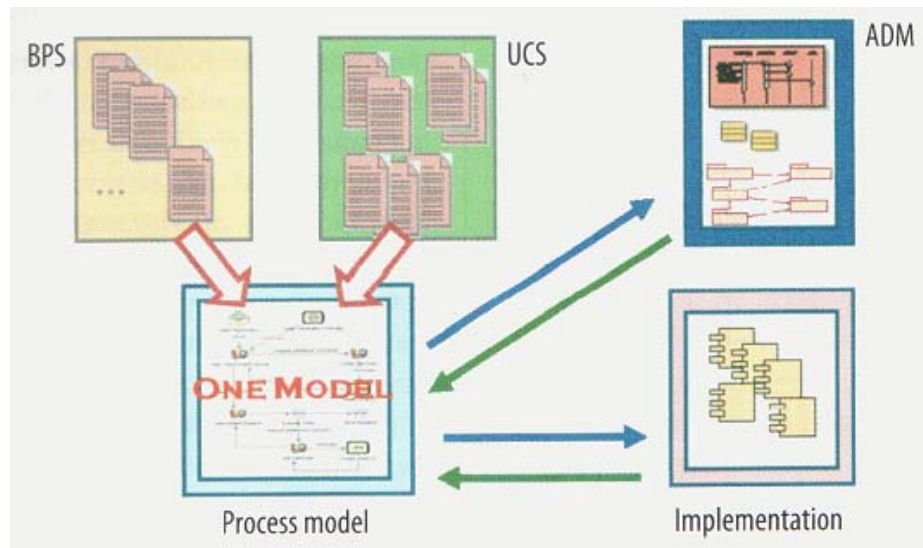

**Image 2 – Continuous model-driven engineering [7]**

Continuous model-driven engineering borrows ideas from above mentioned paradigms. The combination of eXtreme programming, model-driven design and process modeling forms the back bone for what is present day so-called eXtreme model-driven design. This approach is based on models called application logic and could be considered as next stage in process engineering ideas. Main argumentation in this newly developed or derived approach is that several cases have been already successfully implemented. From the viewpoint of this thesis it is still the business process management which is providing the essential knowledge base.

In spite of the fact that business process management approach together with business process modeling is new age modern corporate business system, it is possible to observe following trend of convergence of such modern approaches into brand new one e.g. CMDE. From the view of this thesis it is obviously mandatory to provide users with consolidated forms of approaches. There is a bit of confusion within converging methodologies these days. However, CMDE seems to be showing tremendously sophisticated potential.

## 4 Business process modeling notation

### 4.1 Object Management Group

This chapter is supposed to introduce the present leader in object driven industry standard specifications development which is called Object management Group. OMG was founded in 1989 as the first organisation with very close relation to business engineering, reengineering and business development. The membership within this organisation is open which means that any company can become a member company and participate on development. Present day there is no more significantly important organisation in the area of business process management. It is a nonprofit computer industry standards consortium that produces, controls and maintains many specifications for many kinds of methodologies, notations and approaches [3]. Technology vendors are development leaders in this organisation which is including also end users, government agencies, academic resources and organisations. The main reason why is this organisation so huge present day is that those biggest vendors, huge amount of end users and vast number of academics participated within process driven projects so far. Member companies write as well as adopt and maintain its specifications following a mature, open process implementing breaking approaches and supporting global development.

Specifications implementing the model driven architecture in this case maximize companies returns of investment through a full-lifecycle approach to enterprise integration so it is not just work for free. OMG is the most important as well as fully respected organisation which does not compete any other cell within business development environment. Their specifications are fully trusted as there is reasonable reason through OMG's work already spent on the past development.

OMG's specifications include UML<sup>13</sup>, COBRA<sup>14</sup>, Common Warehouse Metamodel and industry specific standards for dozens of industries which also include Business Process Management Notation being researched in following chapters. All of OMG's formal specifications may be downloaded without any charge from their websites. More information on the OMG is available at <http://www.omg.org/>. When it comes right at UML there is a significant sign of convergence between BPMN and UML. Following image demonstrate importance of BPMN within OMG website in connection with UML.

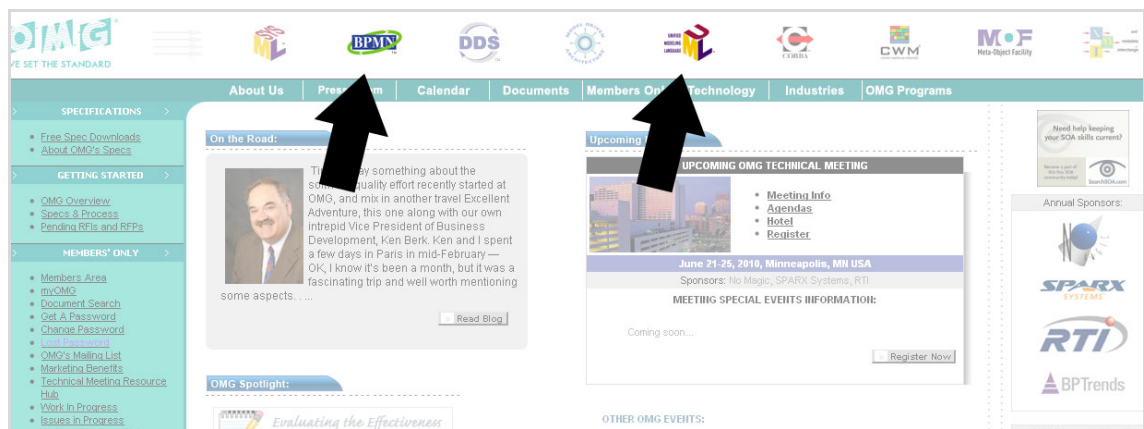

Image 3 – OMG.org

In June of 2005, the Business Process Management Initiative and the Object Management Group announced the merger of their business process management activities in order to provide business environment with proper leadership for industry standards. The combined group has named itself the Business Modeling & Integration (BMI).

*Definition [3]: The primary goal of BPMN is to provide a notation that is easily understandable by all business users and participants.*

<sup>13</sup> Unified Modeling Language

<sup>14</sup> Common Object Request Broker Architecture

Many participants from business analysts that create the initial drafts of the business processes to the technical developers responsible for implementing the technology that will perform those processes are assumed to join the area of business process management and use the advantages of the notation for business process modeling. Finally, business people who will manage, control and monitor those implemented business processes are supposed to hit those advantages as well.

## 4.2 Brief introduction to BPMN

BPMN<sup>15</sup> creates a bridge for the gap between the business process design and process implementation, which is the most important value added to this notation because this bridge is also standardized. It is always difficult task to find out which way is the the most suitable for filling such computer human language gap. Without such bridge there would be many people not able to participate in business development or process reengineering projects and the work coordination within companies would be much more complicated. Another very important goal is to ensure that XML<sup>16</sup> languages designed for the execution of business processes can be visualized with a business oriented notation. The intent of BPMN is to standardize a business process modeling notation in the face of many different modeling notations and viewpoints as mentioned convergence of UML to BPMN.

There was a lot of activity in the past few years in order to develop web based XML execution languages for Business Process Management systems (hereinafter BPM systems) because there was a huge need for that transformation from notation to execution language. Languages such as BPEL4WS<sup>17</sup> do provide a formal mechanism for the definition of business processes. The optimization of these languages for software operations convert them into less suitable form for direct use by humans to

---

<sup>15</sup> Business Process Modeling Notation

<sup>16</sup> Extensible Markup Language

<sup>17</sup> Business Process Execution Language For Web Services

design, manage, and monitor business processes. Thus, such suitability is the key element in the particular development of industry standards.

Technical bases provide the foundation of business process execution with complex nature of both internal and external interactions and take advantage of the benefits of widely spread web services. Business professionals are supposed to be very comfortable with visualizing business processes for example in a form of flow charts or any other easy to read notation. This creates technically oriented gap between the format of the initial design of business processes and the format of the languages, that will execute these business processes properly. This gap needs to be connected with a formal mechanism that maps the appropriate visualization of the business processes called notation to the appropriate execution format called a BPM execution language for these business processes [7].

Design of business processes at the human level can be solved with standardized definition of the Business Process Modeling Notation (hereinafter BPMN), much easier than at the software development level. There is a Business Process Diagram (BPD) provided within BPMN, which is a diagram designed for use by the people who design and manage business processes. BPMN also provides a particular mapping to an execution language of BPM Systems (BPEL4WS in version 1.1). Thus, BPMN does provide a standard visualization procedure for business processes which is also defined in an execution oriented business process language.

BPMN provides businesses with the capability of understanding internal business procedures in a graphical form and gives organizations the ability to communicate these procedures in a particular easy to use notation. There are currently many of process modeling tools and methodologies. Given that users usually move from one company to another and that companies merge and diverge, it is probable that business analysts are required to understand various representations of business processes. Different forms of the same processes as they step through the lifecycle of development, implementation, execution, monitoring, and analysis. Thus, a standard



graphical notation will facilitate the understanding of the business staff collaborations and business transactions within and between the organizations. This ensures that businesses are to be understood and participants in their business are to enable organizations to adjust to a new internal and external business circumstances quickly enough. To do this, BPMN follows the traditional principle of flow chart notations for readability and still provides a mapping to the executable languages.

Using of experience of the business process notations that have preceded BPMN to create the next generation notation which would combine readability, flexibility, and expandability was the key approach to build up effective solutions. BPMN also advances the capabilities of traditional business process notations by handling external business process concepts. Public and private processes as well as advanced modeling concepts, such as exception handling, transactions, and compensation are fully implemented in this notation. BPMN is constrained to support only the concepts of modeling that are applicable to business processes otherwise the clarity of notation would not be so amazing. This means that other types of modeling done by organizations for business purposes will be out of scope for BPMN. Following is absolutely not a part of BPMN [7]:

- Organizational structures and resources
- Functional breakdowns
- Data and information models
- Strategy
- Business Rules

### 4.3 BPMN and processes

Business process modeling as an approach is used to communicate various amount and forms of information to a wide variety of users, hence business participants. It was always important to develop any tool which would be that universal and also so highly professional. BPMN is designed to cover many forms and types of modeling styles. The

structural elements of BPMN allow the reader to be able to easily differentiate between sections of a BPMN diagram which is the main value added of this notation. There are three basic types of sub-models within an BPMN model [7]:

- Private (internal) business processes
- Abstract (public) processes
- Collaboration (global) Processes

#### 4.3.1 Private business process

Private or also called internal business processes are those which can be executed within a specific organization. It is possible to imagine those processes as basic business procedures in order to perform business results. Such processes are those types of processes that have been generally called workflow or BPM processes. A single private business process may be mapped to one or more execution language documents. If lanes are used, then a private business process will be contained within a single pool. Terms lane and pool will be described in the following parts.

The sequence flow of the internal private process is therefore contained within the pool, can be imagined as regular swimming pool, and cannot cross the boundaries of the pool which is the most important rule. Message flow can cross the pool boundary in order to show the interactions that exist between separate private business processes. Thus, a single business process diagram may show multiple private business processes.

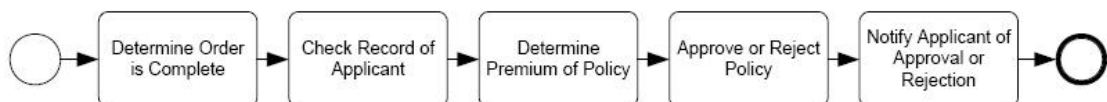

**Image 4 – Example of private business process (OMG.org 2010)**

### 4.3.2 Abstract business process

Abstract, or if you want, public processes represent the interactions between a private business processes and another processes or participants [7]. Only activities used to communicate outside of the private business processes, and the appropriate flow control mechanisms, are possible to use within abstract process model. Thus, the abstract process shows the outside process which is not fully known to organisation and can be modeled as pool without any details. A sequences of messages are required to interact with that business processes in order to provide the communication. Abstract processes are contained within a pool and can be modeled separately or within a larger BPMN diagram. To show the message flow between the abstract process activities and other entities there is particular element of message flow designed within BPMN.

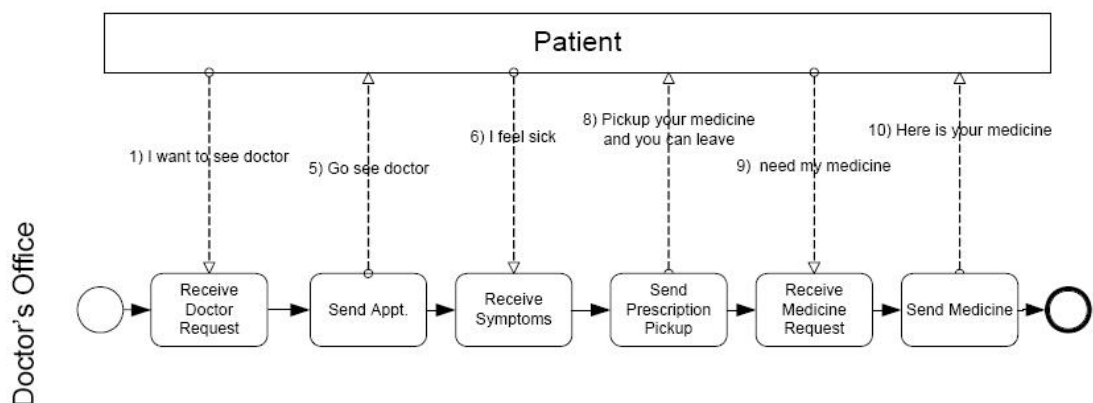
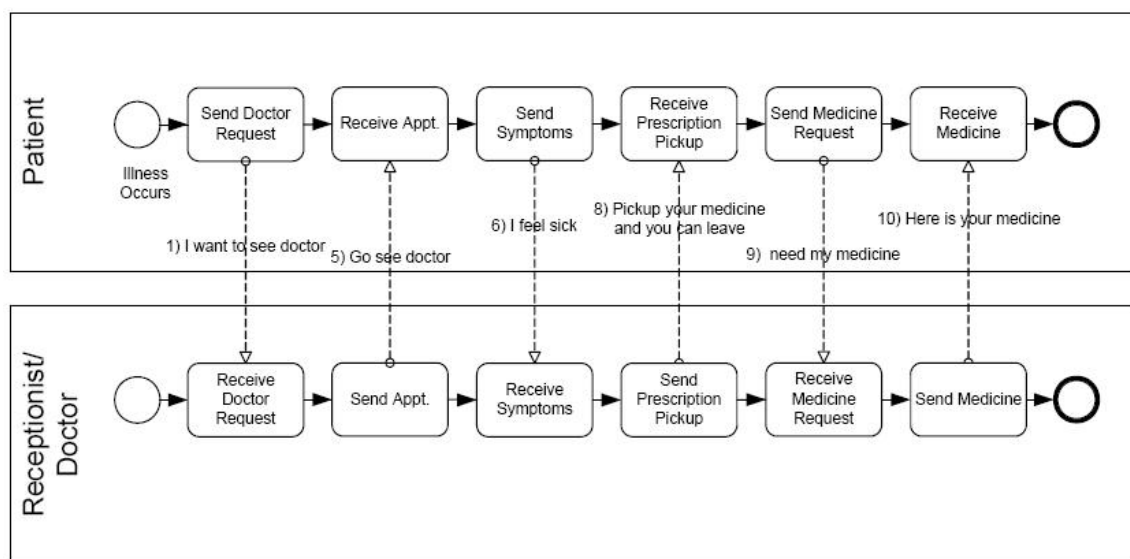

**Image 5 – Example of an abstract business process (OMG.org 2010)**

### 4.3.3 Collaboration business process

There is one more type of processes. A global also called collaboration process shows the communication between two or more business participants which could be either participants or processes as well. These interactions are defined as a sequence of activities that represent the message exchange between the entities involved within collaboration process. It is worth mentioning those processes involved inside

collaboration model are fully known and usually located within one single organisation. A single collaboration process may be mapped to various collaboration languages. In some cases the collaboration process can be shown as two or more processes communicating with each other. With an abstract process, the activities for the collaboration participants can be considered as touch points between the participants. The actual executable processes are likely to have much more activity and details than what is shown in the abstract processes.



**Image 6 - Example of a collaboration business process (OMG.org 2010)**

#### 4.4 BPMN mappings

BPMN industry standard is very universal tool and since it covers many of business areas it became multi-mapping. It is possible to map to more than only one execution language of lower level specification and basically it is important in order to conduct proper decision making on which platform to use and what resource is needed. The mapping is important from the viewpoint of computer processing of model where it is mandatory to use particular languages for particular platforms. In this place the

importance of standardization plays a key role. Following are several cases of lower level specifications [7]:

- BPEL4WS<sup>18</sup> is primary language which BPMN map to within last full standardized specification. This actual language family only cover a single executable private business processes. In case of BPMN diagram contains more than one internal business process a separated mapping for each of the internal business processes is needed
- The abstract sections of a BPMN diagram can be mapped to web service interfaces specifications, such as the abstract processes of BPEL4WS
- Collaboration models of a BPMN may be mapped to collaboration models such as ebXML BPSS<sup>19</sup>, RosettaNet, and the W3C<sup>20</sup> Choreography Working Group Specification (when it is completed)

BPMN specification 1.1 from OMG only covers a mapping to BPEL4WS. Mappings to other specifications have to be found by a separate effort, or perhaps a future direction of BPMN. It is hard to predict which mappings will be applied to BPMN at this point, since process language specifications are a unstable area of work. With many new offerings and mergings there are many derivatives that can aspire for top level usage. A business process diagram is not designed to graphically represent all the information required to execute a business process. Thus, the graphic elements of BPMN are supported by attributes that will supply the additional information required.

---

<sup>18</sup> Business process execution language for web services

<sup>19</sup> eBusiness eXtensible markup language business process specification schema

<sup>20</sup> World wide web consorcium

## 4.5 BPMN core elements set

Brief summary of the BPMN graphical objects and their relationships will be described in this part of the thesis. It is not the primary objective of this chapter to describe all necessary elements of BPMN but point out those needed to rough description of the notation in order to understand the concept. That was a huge goal for the development of BPMN to make the notation as simple as possible and adoptable by various kinds of business analysts within various industries. The list of BPMN graphic elements is presented in two groups.

First group of elements is the list of core elements. Those elements basically support the requirement of a simple notation and define the basic situations realised within BPMN. As a single elements they cannot be used, extended set of elements will define usable items then. It is likely that most of business processes are to be modeled with these elements and no diagram could even exist without atleast one core element. There is extended list of elements, core elements included, which will help support requirement of a powerful notation to handle more advanced modeling situations.

It should be emphasized that one of the drivers for the development of BPMN is to create a simple mechanism for creating business process models, while at the same time being able to handle the complexity belonging to business processes. The approach to handle these two conflicting requirements was to organize the graphical aspects of the notation into specific categories. This provides a small set of notation categories so that the reader of a BPMN diagram can easily recognize the basic types of elements and understand the diagram. The four basic categories of elements are [7]:

- Flow Objects
- Connecting Objects
- Swimlanes
- Artifacts

Flow objects are the main graphical elements to define the behavior of a business process. There are three flow objects within the specification:

- Events
- Activities
- Gateways

There are three ways of how to connect flow objects to each other or with other information:

- Sequence Flow
- Message Flow
- Association

There are two ways of grouping the primary modeling elements:

- Pools
- Lanes

Artifacts are used to provide additional information about the processes which is delivering the total usability of BPMN notation. There are three standardized artifacts, but it is kind of important to add that vendors of modeling tools are free to add as many artifacts as required. The current set of artifacts include:

- Data Object
- Group
- Annotation

It is possible to check out these artifacts while they were all used within case study in the following chapter.

#### 4.5.1 Event



**Image 7 – Event element (OMG.org 2010)**

An event is something that happens during the business process. Good example of event is for example accepted message, or message inbox alert. These events affect the flow of the process and usually have a cause (trigger) or an impact (result). Events are circles with open centers for internal markers to differentiate different triggers or results. There are three types of events, based on when they affect the flow [7]:

- Start event
- Intermediate event
- End event

#### 4.5.2 Activity



**Image 8 – Activity element (OMG.org 2010)**

Any work procedure performed is supposed to be called activity. If a business participant must spend time and produce any kind of work it is surely the case of activity. An activity can be atomic (no sub-activity is possible) or non-atomic. The types of activities that are a part of a process model are: process, sub-process, and task. Tasks and sub-processes are rounded rectangles. Processes are contained within a pool and lanes (explained in the following text).

#### 4.5.3 Gateway



**Image 9 – Gateway element (OMG.org 2010)**



There is also need to control the divergence and convergence of sequence flow. Thus, gateway determines forking, merging, and joining of paths. As it is core element the internal markers will indicate the type of behavior control within gateway. It is possible to add here that BPMN gateways are very similar to several different object oriented notations. It is very intuitive to use them at all.

#### 4.5.4 Sequence flow



**Image 10 – Sequence flow (OMG.org 2010)**

The direction of the process flow within business environment is represented by primary element of a sequence flow, which is used to show the order that activities are to be performed in a process. The arrow shows the direction of work progress inside the process.

#### 4.5.5 Message flow

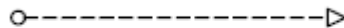

**Image 11 – Message flow (OMG.org 2010)**

It is always important that communication within and outside organisation is the key objective in order to fulfil company goals. A message flow is used to show the flow of messages. Those messages are usually executed between two participants that are prepared to send and receive them. In BPMN, it is possible that two separated pools in a diagram represents the two participants (e.g. doctor and patient) hence in case of abstract processes it is possible for event to send message to an pool.

#### 4.5.6 Association

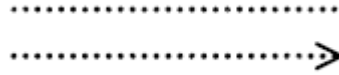

**Image 12 – Association (OMG.org 2010)**

An association is used to associate items, mostly information with flow objects. Text and graphical non-flow objects can be associated with flow objects as well. In the case study conducted in the following chapters it is possible to check out practically used association elements. An arrow on the association indicates a direction of flow (e.g. data).

#### 4.5.7 Pool



**Image 13 – Pool element (OMG.org 2010)**

A pool is primary division for processes which represents a participant in a process. It also acts as a swimlane and a graphical container for partitioning a set of activities from other pools. Everything that is supposed to be a business process must be situated within any pool [7]. As mentioned we can use pools like participants and when it comes to organisations it can represent e.g. departments. Pool can be put in the business process diagram modeled within BPMN absolutely empty in case of abstract processes.

#### 4.5.8 Lane

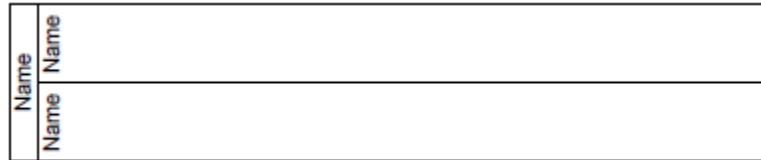

**Image 14 – Lane element (OMG.org 2010)**

A lane could be called sub-pool within a pool. It extends the entire length of the pool, either vertically or horizontally. Lanes are used to organize and categorize activities [7]. Good example of lane usage within organisation example it department and positions where single positions are represented by lanes:

- Pool: Development department
  - Lane: Coding
  - Lane: Programming
  - Lane: Testing
  - Lane: Design
- Pool: Company
  - Lane: Human resources
  - Lane: Project management
  - Lane: Internet marketing

#### 4.5.9 Data object



**Image 15 – Data object (OMG.org 2010)**

Data objects are considered artifacts because they do not have any direct effect on the sequence flow or message flow of the business processes. What is real advantage of

those elements is that they do provide information about what activities require to be performed. Data objects can be used for example even for paper contracts symbols.

#### 4.5.10 Group



**Image 16 – Group (OMG.org 2010)**

This element is supposed to be used within grouping of activities that are in the same category or area of interest. This type of grouping does not affect the sequence flow of the activities within the group at all in the contrary it contributes to clarity of flow. The category name appears on the diagram as the group label. Categories can be used for documentation or analysis purposes [7]. Sometimes it is useful to depict the category within large model just for visibility and clearness of solution.

#### 4.5.11 Text annotation

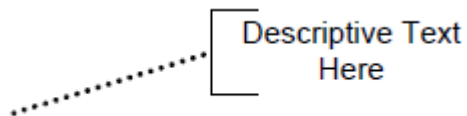

**Image 17 – Text annotation (OMG.org 2010)**

Text annotations are a mechanism for a modeler to provide additional information for the reader of a business process diagram.

## 4.6 Extended set of BPMN core elements

### 4.6.1 Extended event



**Image 18 – Extended event elements (OMG.org 2010)**

As the name implies, the start event indicates where a particular processes start or where the particular business procedure begins. Intermediate events always occur between a start event and an end event. They affect the flow within the process, but do not start or directly terminate the process. The termination itself is handled by, as the name implies as well, the end event. End event can be found at the highest level of processes, but also as subprocess terminator inside lower level of the model.

Start and almost all intermediate events have triggers that define the cause for the event (e.g. incoming message). There are multiple ways how these events can be triggered like message, timer or error. End events may define a result that is a consequence of a sequence flow ending, thus they are only throwing. Start events on the contrary can only react to a trigger, catch a trigger.

Finally intermediate events can either catch or throw triggers which makes them suitable aspirants for frequent usage. There is unfilled marker when it comes to catching events and filled marker for throwing events. It is worth mentioning that within some computer aided modeling tools the marking system is fully automated according to the design process. E.g. it is being marked according to message flow element direction.

	"Catching"		"Throwing"	
No Trigger				
Message				
Timer				
Error				
Cancel				
Compensation				
Conditional				
Link				
Signal				
Terminate				
Multiple				

**Image 19 – Extended events – triggers (driveintobpm.org 2010)**

As is shown, there are many types of events while the most universal is the intermediate event. It has most of the types included within specification and even usage inside processes makes them important. If we want to mention most popular triggers we would use message, timer, error or link and signal. Very interesting one is signal, which sends the echo all around the place waiting for any response.

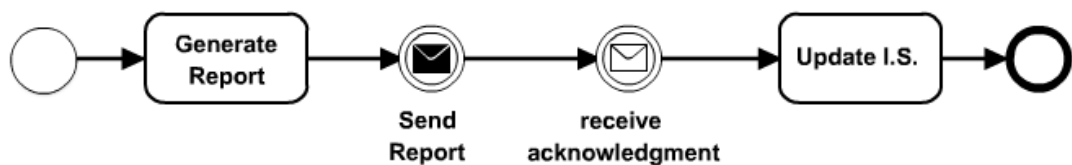

**Image 20 – Example of throwing and catching event (driveintobpm.org 2010)**

Example listed above is the simplest case of four elements usage within process structure formed and designed by business process modeling notation. As is denoted the process itself consists from four elements. Two of them are alike. They are activity elements representing particular activity which could be in some cases defined as sub-process as well. Rest of the elements are events with special characteristics. The one with solid envelope is event throwing message to recipient from private, collaboration or global process. Second one with the empty envelope is event element catching message. In this case it is also recipient in a way.

#### 4.6.2 Extended activity

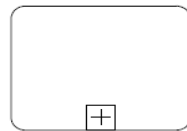

**Image 21 - Collapsed sub-process (OMG.org 2010)**

The details of the sub-process are not visible in the diagram when collapsed notation used [7]. A plus sign in the lower center of the shape indicates that the activity is a sub-process and has a lower level of detail. Which means that after expansion there is possible to observe brand new processes.

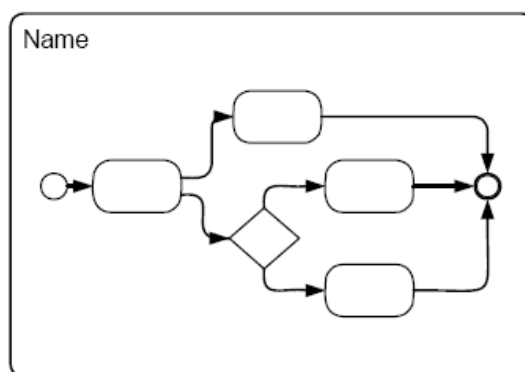

**Image 22 – Expanded sub-process (OMG.org 2010)**

When expanded notation used details of sub-process are visible. The boundary of the sub-process is expanded and note that sequence flow cannot cross the boundary of a

sub-process. That is a standardized approach and most of tools do not provide such error making option.

#### 4.6.3 Extended sequence flow



**Image 23 – Conditional flow (OMG.org 2010)**

Sequence flow can have condition expressions that are evaluated at runtime to determine whether or not the flow will be used [7]. There are two ways how the conditional flow can be depicted. If the conditional flow is outgoing from an activity, then the sequence flow will have a mini-diamond at the beginning of the line. If the conditional flow is outgoing from a gateway, then the line will not have a mini-diamond. It will be just straight arrow.



**Image 24 – Default flow (OMG.org 2010)**

There is a special type of flow defined for data-based exclusive decisions or inclusive decision points. Such type of flow is the default condition flow. This flow is used only if all the other outgoing conditional flow is not true at runtime. It is just default solution in case of global error. Notation of these sequence flows contains a diagonal slash added to the beginning of the line.

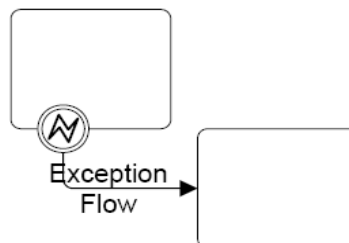

**Image 25 – Exeption flow (OMG.org 2010)**



Regular flow element has also one more utilization within business process modeling notation. It can be modeled as an exception flow. Exception flow occurs outside the normal flow of the process and is based upon an intermediate event that occurs during the performance of the process.

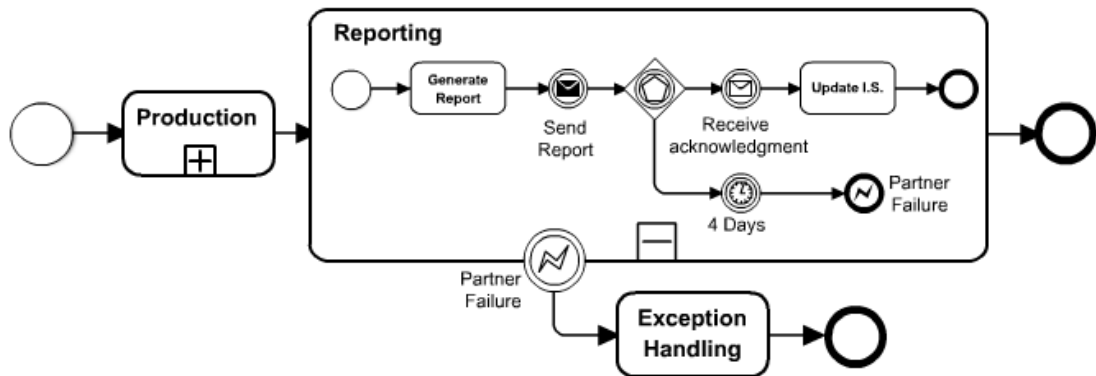

**Image 26 – Example of interruption within process (driveintobpm.org 2010)**

There is a sub-process modeled in the example above, and as can be seen if 4 days timeout happens within timer event, exception handling activity would be conducted. It is the consequence of handling by exception flow when sub-process ends up by partner failure and the event throw error which is ultimately caught by catching event on the boundary of the sub-process.

#### 4.6.4 Extended association

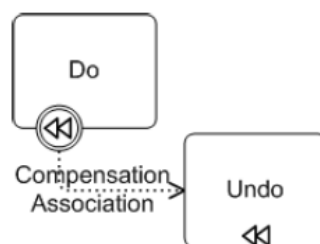
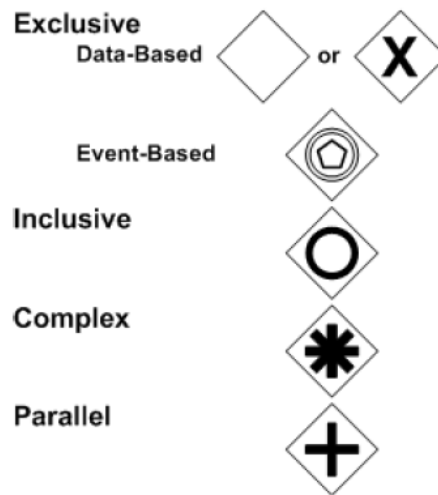

**Image 27 – Compensation association (OMG.org 2010)**

Extended association has one form of element which is worth mentioning. It is compensation association which occurs outside the normal flow of the process and is

based upon an event (a compensation intermediate event) that is triggered through the failure of a transaction or a compensate event. The target of the association must be marked as a compensation activity. An example could be a credit card charges refunds while error occurred during transaction.

#### 4.6.5 Extended gateway



**Image 28 – Gateway control types (omg.org 2010)**

There are icons within the diamond shape which indicate the type of flow control behavior of gateways. As shown there are four basic type of gateways like exclusive, inclusive, complex and parallel. The types of control include [7]:

- Exclusive decision and merging
  - Both data-based and event-based
  - Data-based can be shown with or without the “X” marker
- Inclusive decision and merging
- Complex – complex conditions and situations
- Parallel forking and joining
  - Each type of control affects both the incoming and outgoing flow

## 4.7 Extended gateways behaviour

### 4.7.1 Exclusive data-based gateway

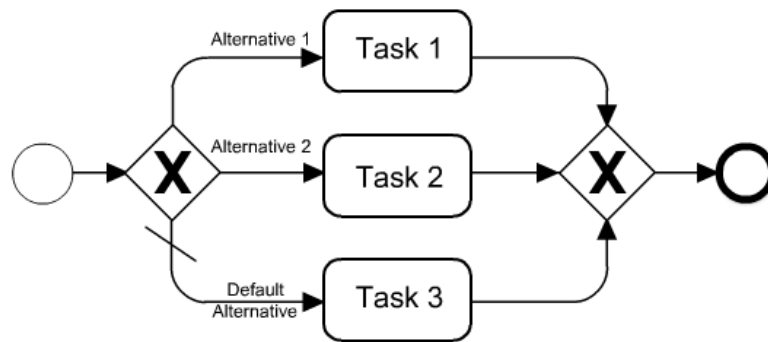

**Image 29 – Data-based gateway within process (driveintobpm.org 2010)**

Exclusive data-based gateway is used as a decision point where several outgoing sequence flows are possible. The main concept is given by single condition resolved by one default and several regular alternatives. Thus, those alternatives are all constrained by the condition and only one of them will be used at a time. Such a condition will be evaluated based on the process data. When it comes to situation where it is mandatory to merge several sequence flows into one the gateway waits only for one of them. The incoming execution move straight through the gateway and go on.

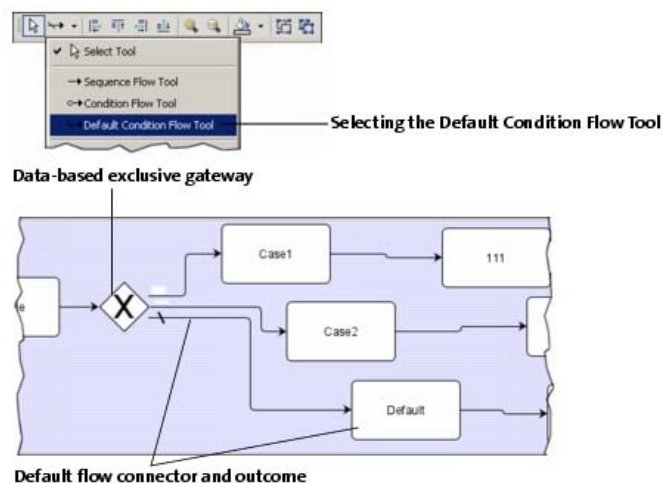

**Image 30 – Data-based gateway in Intalio Designer (Intalio.com 2010)**

Here it is shown how the actual default alternative can be handled within Intalio Designer which was decided to be chosen tool in order to satisfy practical part of this diploma thesis. As is shown it is possible to set up default alternative, thus default flow by using a pop-up menu provided by graphical user interface of the software.

#### 4.7.2 Exclusive event-based gateway

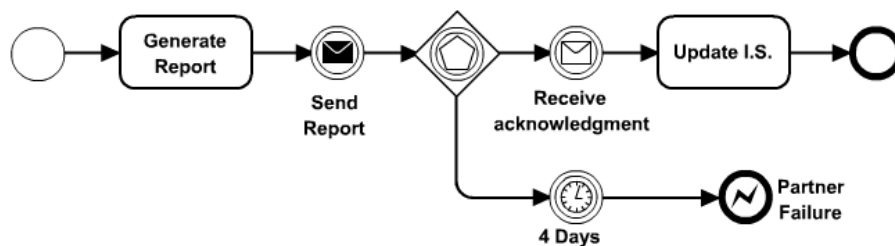

**Image 31 – Event-based gateway within process (driveintobpm.org 2010)**

The only difference of event-based gateway from data-based is that instead of evaluating a condition and set of alternatives to determine only one outgoing flow, the event-based gateway starts a listening state between the different events the process might receive and the first one to be received determines which outgoing sequence flow should be used. On the example above if acknowledgement received before four hours timeout then message will be accepted. If received after timeout of four hours then no message will be accepted.

#### 4.7.3 Parallel gateway

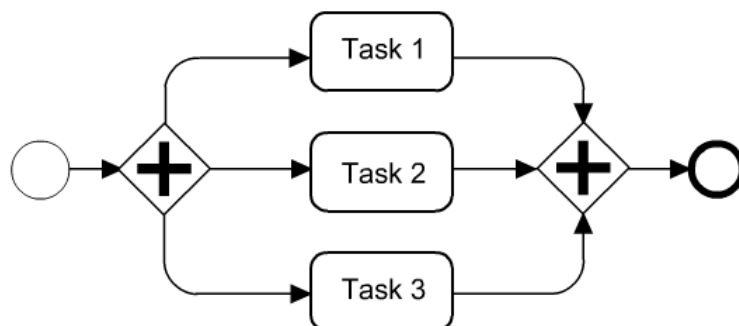

**Image 32 – Example of parallel gateway (driveintobpm.org 2010)**

Another gateway with special kind of behaviour is parallel gateway. It provides a mechanism to synchronize parallel flow and of course to create parallel flow. These gateways are not required to create parallel flow at all. There are options within BPMN which provide users with mechanism of sequence flow suitable for creating parallel flow. But parallel gateways can be used to clarify the behavior of complex situations where a string of gateways is used and parallel flow is required [7]. In addition of the example above the first gateway generates parallel flow and the second one does not go on until all tokens arrive. That is the main point when using parallel gateway for synchronization.

#### 4.7.4 Inclusive gateway

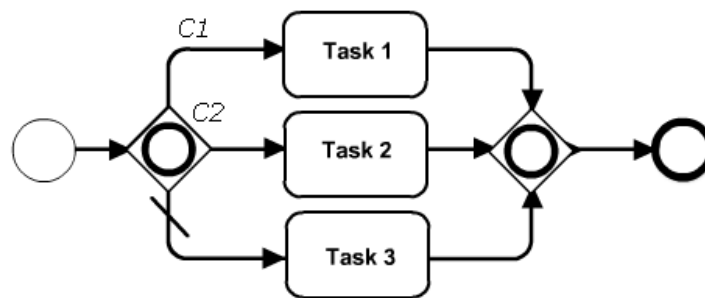

**Image 33 – Example of inclusive gateway (driveintobpm.org 2010)**

Decision making within this kind of gateway is represented by the point where alternatives are based on conditional expressions contained within outgoing sequence flow. However, in this case the true evaluation of one condition expression does not exclude the evaluation of other conditions. Thus, there can be all of conditions true evaluated and ongoing flow will step through all of them. In this point it is worth to mention the essentials of binary algebra. Since each path is independent, all combinations of the paths may be taken, from zero to all. However, it should be designed so that at least one path is taken.

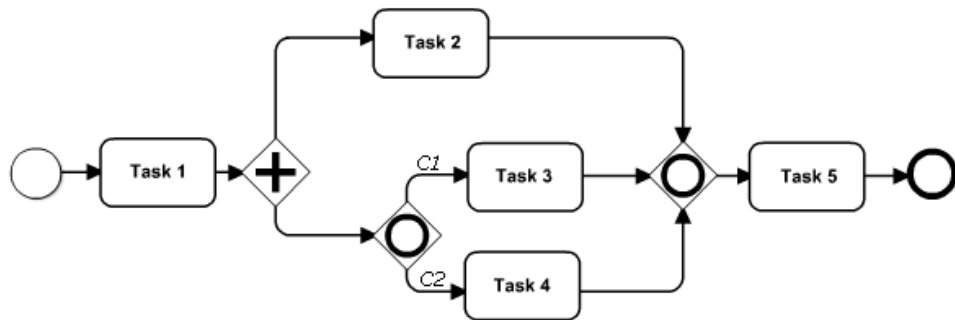

**Image 34 – Inclusive gateway combined with parallel (driveintobpm.org 2010)**

As a merge, the inclusive gateway will synchronize, hence wait for all of the execution points produced upstream but at most one for each incoming sequence flow [7]. From the example above it is obvious that last inclusive gateway will not release token until all three arrive.

#### 4.7.5 Complex gateway

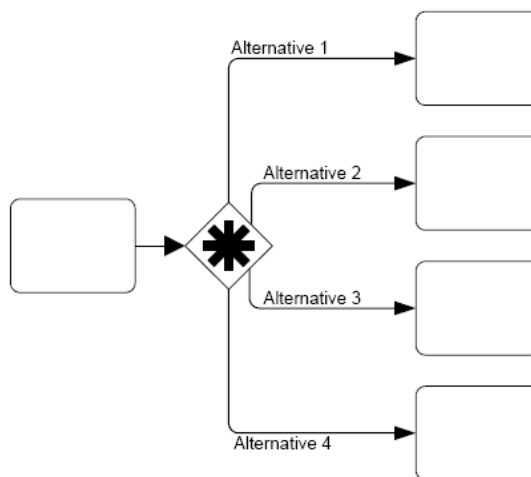













**Image 35 – Example of complex gateway (OMG.org 2010)**

The complex gateway was created to address complex cases which would require the combination of several other gateways. To avoid this, the behavior of the complex gateway can be scripted using an expression language. As a result the complex gateway can be used to handle every situations. Best practice is to avoid it since it makes the process models less readable.

## 4.8 Flow object connection rules













There are several rules within BPMN that provide users with strict constraints in order to bring those modeled cases into clear form. First of all it is worth to mention basic rules of flows. An incoming sequence flow can connect to any location on an object as well as outgoing sequence flow can connect from any location on an object. This is usually properly handled by software used for modeling. Message flow also have this capability and BPMN allows this flexibility. However, it is recommended to modelers to use judgment or best practices in how flow objects should be connected so that readers of the diagrams will find the behavior clear and easy to follow. In case of computer based modeling tools it is almost always handled automatically.

There are also connection rules which vary according to starting and ending point, thus element. Following table displays the BPMN flow objects and shows how these objects can connect to one another through sequence flow. The arrow symbol indicates that the object listed in the row can connect to the object listed in the column. The quantity of connections into and out of an object is matter of particular cases of solution and are not specified here. Note that if a sub-process has been expanded within a diagram, the objects within the sub-process cannot be connected to objects outside of the sub-process. Nor can sequence flow cross a pool boundary. From the table is also obvious that e.g. no gateway can precede the start event neither can activity nor sub-process and so on.

From\To						
		↗	↗	↗	↗	↗
		↗	↗	↗	↗	↗
		↗	↗	↗	↗	↗
		↗	↗	↗	↗	↗
		↗	↗	↗	↗	↗
						

**Image 36 – Sequence flow connection rules (OMG.org 2010)**

Second table displays the BPMN modeling objects and shows how these objects can connect to one another through message flow. The arrow symbol indicates that the object listed in the row can connect to the object listed in the column [7]. Note that message flow cannot connect to objects that are within the same pool. In this table it is obvious that e.g. event throwing message cannot be caught by another throwing event. Neither can activity throw message to another throwing event.

From\To						
						
	↗	↗	↗	↗	↗	
	↗	↗	↗	↗	↗	
	↗	↗	↗	↗	↗	
	↗	↗	↗	↗	↗	
	↗	↗	↗	↗	↗	

**Image 37 – Message flow rules (OMG.org 2010)**



Very interesting issue in here is that when it comes to pool throwing a message the fact that pool is actually throwing messages could be a bit weird at the first sight. This is eventually caused by feature which allow abstract business process not to define internal activities on purpose and use the boundaries of the pool to handle messages. It might be added that there is no details known about abstract public business process.

Such a connection rules are also important from additional point of view. This point of view is connected with software developers and vendors of modeling tools for BPMN. Such rules provide suppliers with constraints and make the software usable. It is not necessary to stress how important it the usability for the concept of model driven business architecture.

## II. Project

## 5 Case study

### 5.1 Introduction

This case study is formulated in order to satisfy basic requirements for implementation of open source electronic commerce (e-commerce) solution. Hence, there is absolute need to decide on which tool is about to be used for modeling procedure. There are many computer aided system engineering tools on the market. Anyway, it is not primary objective of this thesis to provide reader with deep review of all available tools because it would be matter for brand new research paper.

Hence, in the first part it is dealing with the tools possible to use for modeling in BPMN. In this place it is not needed to focus just on open source solutions because those community editions of spectacular quality produced by commercial vendors could be missed. Thus in the first part of case study it is dealt with available tools which could be called download-and-model. Of course all researched tools are free of charge.

In the second part of the case study it was decided to model up the implementation of open source solution of e-commerce within BPMN. Primary objective of this part is to demonstrate practical properties of the notation within real situation. No mapping will be provided within this thesis though.

## 5.2 BPMN free tools

### 5.2.1 Intalio Designer

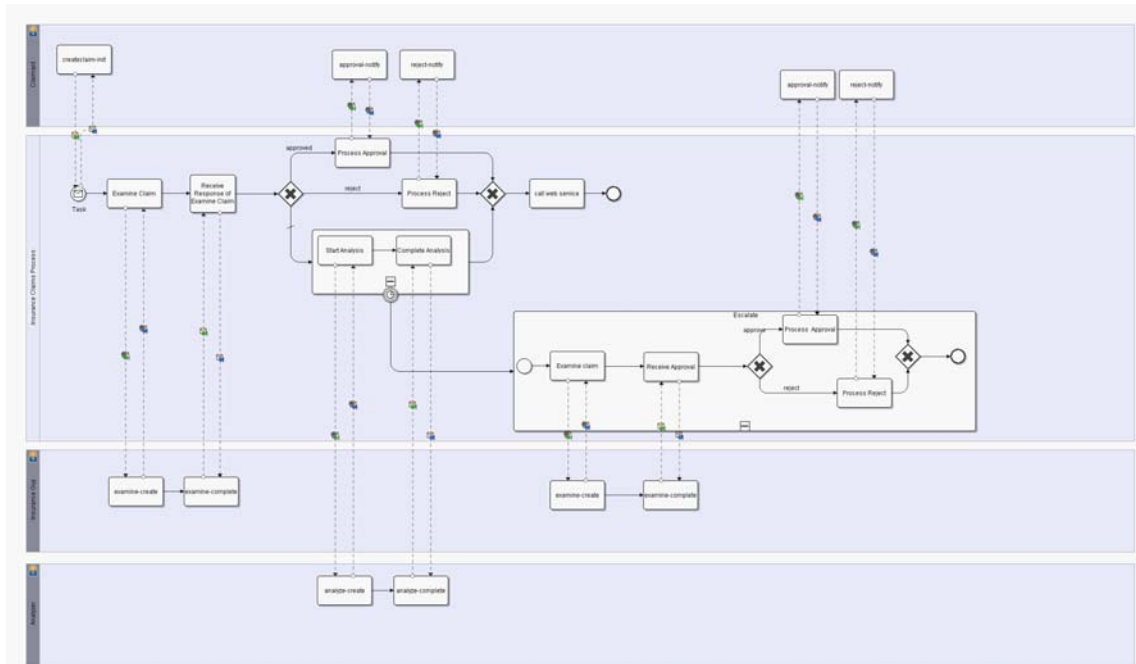

Intalio Works Community Edition is a standards-based BPMS that can be used totally free of charge. With more than 50,000 organizations using it around the world, it is the most widely used BPMS today. It is made of two components: Intalio Works Designer, built around the Eclipse BPMN Modeler, and Intalio Works Server, which embeds the Apache ODE BPEL engine and the Tempo BPEL4People workflow framework [Intalio.com 2010]. All three open-source projects have been originally contributed by Intalio.

Intalio designer which is integrated within this community edition is highly professional tool which provide user with all necessary notation elements and simultaneously holds the usability constraints. While deciding on purchase of commercial solution it would be definitely this one.

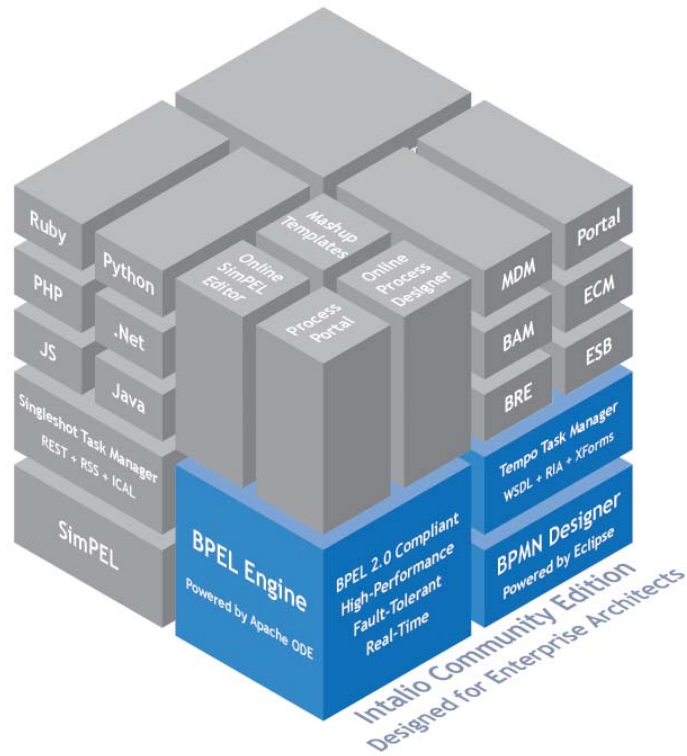
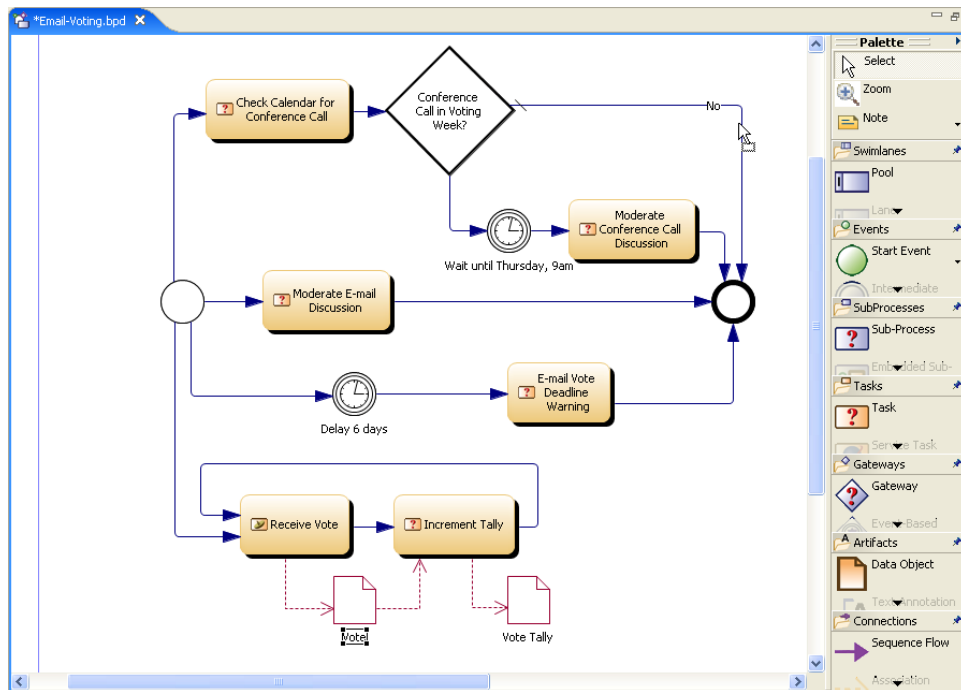

**Image 38 – Intalio platform (intalioworks.com 2010)**

Intalio Works Community Edition is a strict subset of Intalio Works Enterprise Edition, and upgrading from one to the other is as simple as purchasing a subscription and entering a license key. It is necessary to compare the Community Edition and Enterprise edition to see which is right for user.

After a brief research of mostly free available BPMN designers without any download or usage registration obstacles it was decided that Intalio Works Community Edition Designer will be used for the purposes of this diploma thesis. It is highly professional tool which also meet all the needs of standard of BPMN which is fully implemented with sufficient constraints.

## 5.2.2 Soyatec eBPMN Designer



**Image 39 – Soyatec eBPMN Designer (Soyatec.com 2010)**

An advantage that is provided by eBPMN designer is that there is no need of installation. It is possible to just download and use for free of charge, thus behaviour acts like portable. This tool contains all the necessary elements to fully design business process diagram by BPMN. Some elements might vary a little bit, which is result of continuous development of BPMN. This tool provides basic features as it is possible to specify the color and font per element type, the preference values are applied for its subclasses if the subclass hasn't the same preference setting, these preference values are used during the element creation and so on.

It is also possible to change them via property sheets which are very handy. It is also possible to setup the pool orientation in the preference: horizontal or vertical. But this parameter cannot be changed anymore once the diagram is created. This feature prevents the overlay of pools. All pools are kept in the same size in the orientation. Resize of one pool changes all others. A complete connectivity control for sequence flow, message flow and association is implemented through the BPMN specification.

This feature prevents the semantic wrong connection and simplify the use of the tool. After the element creation, it is possible to change the element type. This change is limited for activity and gateway.

### 5.2.3 Gliffy.com

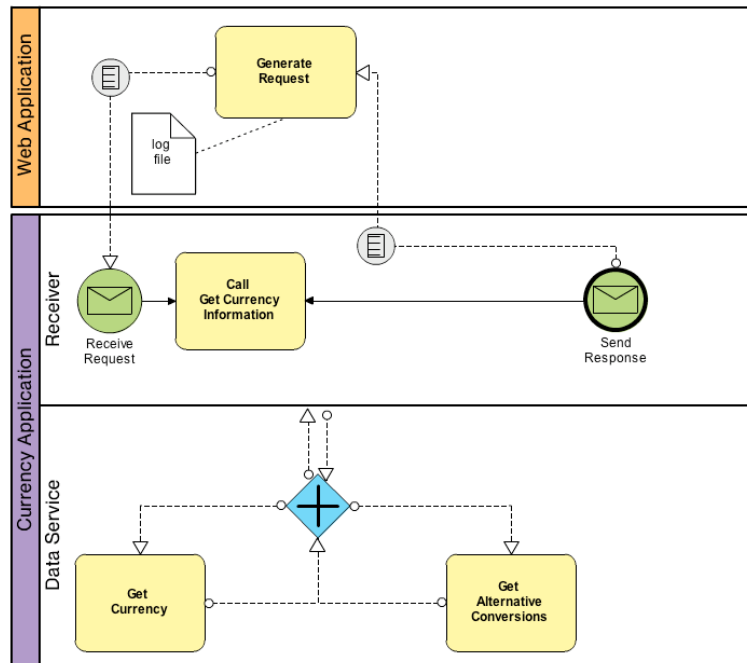
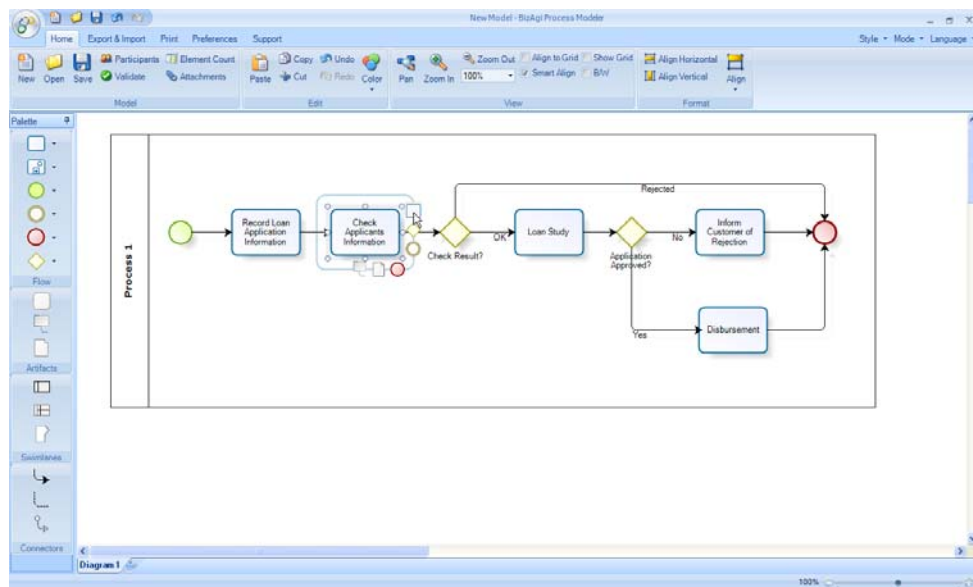

Image 40 – Gliffy.com (2010)

Gliffy.com is internet-based application that provides users with various amount of design standards. Which is more important, it provides users with BPMN designer tool also free of charge as the rule in this thesis was set. Great advantage is that it is possible to get on the same page with particular team and work out the agenda needed. Free business process software from Gliffy delivers the BPMN tools needed to help stakeholders get a clear picture of the business process, while not all services are completely free of charge. With a library of shapes built-in to this business process software, Gliffy business process tools help to create and share professional-looking diagrams with drag-and-drop ease.

This business process modeling software helps new and experienced users create BPMN diagrams quickly. This business process tool looks like office applications, so users can start using business process software immediately. If the team needs to help build up an diagram it is easy enough to enter the site and start off right away.

#### 5.2.4 BizAgI Process Modeler



**Image 41 – BizAgI Process Modeler (bizagi.com 2010)**

BizAgI software is yet another software committed to providing high-quality and graphically advanced tool to customers. We must mention here that graphics appearance with shadows dropped and so on, do not always contribute to professional output but can sometimes act as disturbing. BizAgI has established customer self-service features for basic inquiries, as well as a customer support team that offers a range of services.

Even in this case the tool is free of charge available to download and use. It is possible to watch online how to get started with BizAgI Process Modeler, learn how to use it easily and discover the new functionalities. Documents associated with Business Process Modeling Notation are also available online. The support of this solution is well performed in order to invite users, that would like to use this tool and subscribe commercial features.



## 5.3 Case study - Implementation of e-commerce solution

Objective of this case study is to design up business process management diagram for the situation of open source electronic commerce solution. It is not within limits of this case study to compare what open source solution is better than the other, but to produce rough concept applicable on all of those solutions.

Electronic commerce is already well developed area of business, hence the importance of open source solutions is even more significant in order to provide small and middle business men with alternative solution not so extremely cutting down the company budget. Even in case of open source solution there is particular cost. This cost is mainly assigned to implementation part of this open source electronic commerce system. Provided, that customer is never capable to conduct any implementation step by himself there will be costs at any way. In the contrary this open source solution will save huge cost as it would be spent on regular commercial solution.

### 5.3.1 Business process dictionary

#### 5.3.1.1 Pools

<b>Pool</b>	<b>Description</b>
Client	Business customer which is supposed to order and approve the final solution before payment – in this case it is abstract process
Supplier	Business subject delivering open source electronic commerce solutions – usually IT focused enterprise providing customers with IT related services – in this case it is private process

**Table 1 - Pools**

### 5.3.1.2 Lanes – supplier pool

<b>Lane</b>	<b>Description</b>
Sales	Sales lane representing rough concept of sales department, the main objective of this department is to provide the enterprise with customer contact and manage client related activities
Project management	Project management department representing organisational gap between sales department and development level, the main objective is to manage and plan business projects as well as executing those projects
Development	Development department is main production unit which is providing the enterprise with real workflow within business projects, the main objective of this department is to deliver actual solution

**Table 2 - Lanes – supplier pool**

### 5.3.1.3 Activities

<b>Activity</b>	<b>Pool/Lane</b>	<b>Description</b>
Answer campaign	Client	Respond to marketing campaign of the supplier
Contract evaluation	Client	Evaluation of the contract parameters
Requirements collection	Client	Collection of needed requirements
Approve graphic design	Client	Approval of the graphic design

<b>Activity</b>	<b>Pool/Lane</b>	<b>Description</b>
Payment	Client	Payment processing
Query processing	Supplier/Sales	Processing of query responded
Contract design	Supplier/Sales	Contract parameters design for particular business case
Contract redesign	Supplier/Sales	Contract redesign process if needed so executed
Request payment	Supplier/Sales	Payment request in order to balance provided services
Requirements analysis	Supplier/Project management	Requirements analysis of the particular solution
Webhosting setup	Supplier/Project management	Webhosting setup for particular solution
Graphic approval	Supplier/Project management	Graphic design approval procedure
Project closure	Supplier/Project management	Project closure within business boundaries
Graphic design	Supplier/Development	Graphic design of the user interface for particular solution
Upload installation package	Supplier/Development	Upload of particular version of solution to prepared web space
System setup	Supplier/Development	Regular system setup for future usage, tasks as nice URL's and so on

<b>Activity</b>	<b>Pool/Lane</b>	<b>Description</b>
Template coding	Supplier/Development	Coding of the template to be implemented
Template upload	Supplier/Development	Implementation of the particular template design
Testing	Supplier/Development	Testing of particular solution

**Table 3 - Activities**

### 5.3.2 Solution

#### 5.3.2.1 Business process diagram preview

Following diagram is to show the basic overview above this particular business case. It is the process of implementation of open source electronic commerce solution. Such solution could be represented as for example Drupal content management system with specific electronic commerce modules or osCommerce open source e-commerce solution. There are several pools, lanes, activities and so on defined in the following diagram in order to satisfy the case of this particular business service.

There are two main pools within the business process diagram. First of all is pool for abstract process of client. It is public process representing potential business customer and also representing the sequence of tasks (activities) which are needed to be executed in order to achieve requested result of solution needed within electronic commerce. There are four main parts within this particular business process diagram. First of all there is contract design block which basically show us the procedure of contract preparation, parameters negotiations and finally approval by the side of potential customer. Second main block of activities is focused on project planning which also includes requirements analysis. Third main block deals with graphics design of user interface and delivers so controlling platform for future users, thus customers of customer. This transitivity has significant part on delivering the final business performance. There is a stage of template coding and testing in the end as well as project

closure followed by payment request. Coding of the template is bigger agenda when it comes to the time consumption. This fact is caused by the need of cross browser compatibility these days.

As will be shown in the next two pages it is possible to observe two business process diagrams that were built up by Intalio Designer computer aided tool for development of business process management systems. First of all there is a full example of the diagram with all sub-processes collapsed. Expanded view of the entire diagram is following right after.

When it comes to pools and lanes design it is possible to note that client pool is somehow presented in darker color. This property is caused by the fact that client process is abstract public process with no extra details known. Thus, there is a system preference within Intalio Designer for this feature.

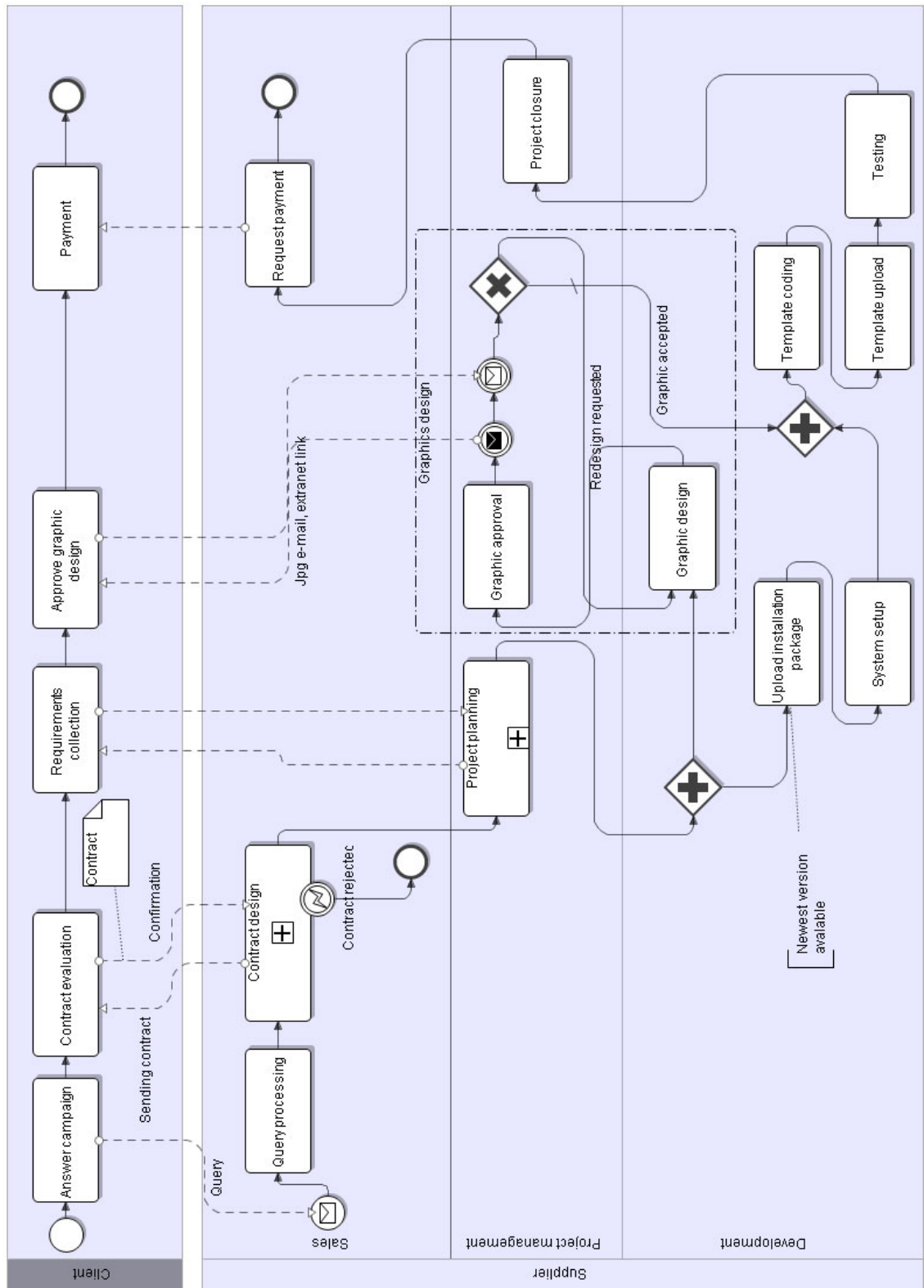

Image 42 – Business process diagram

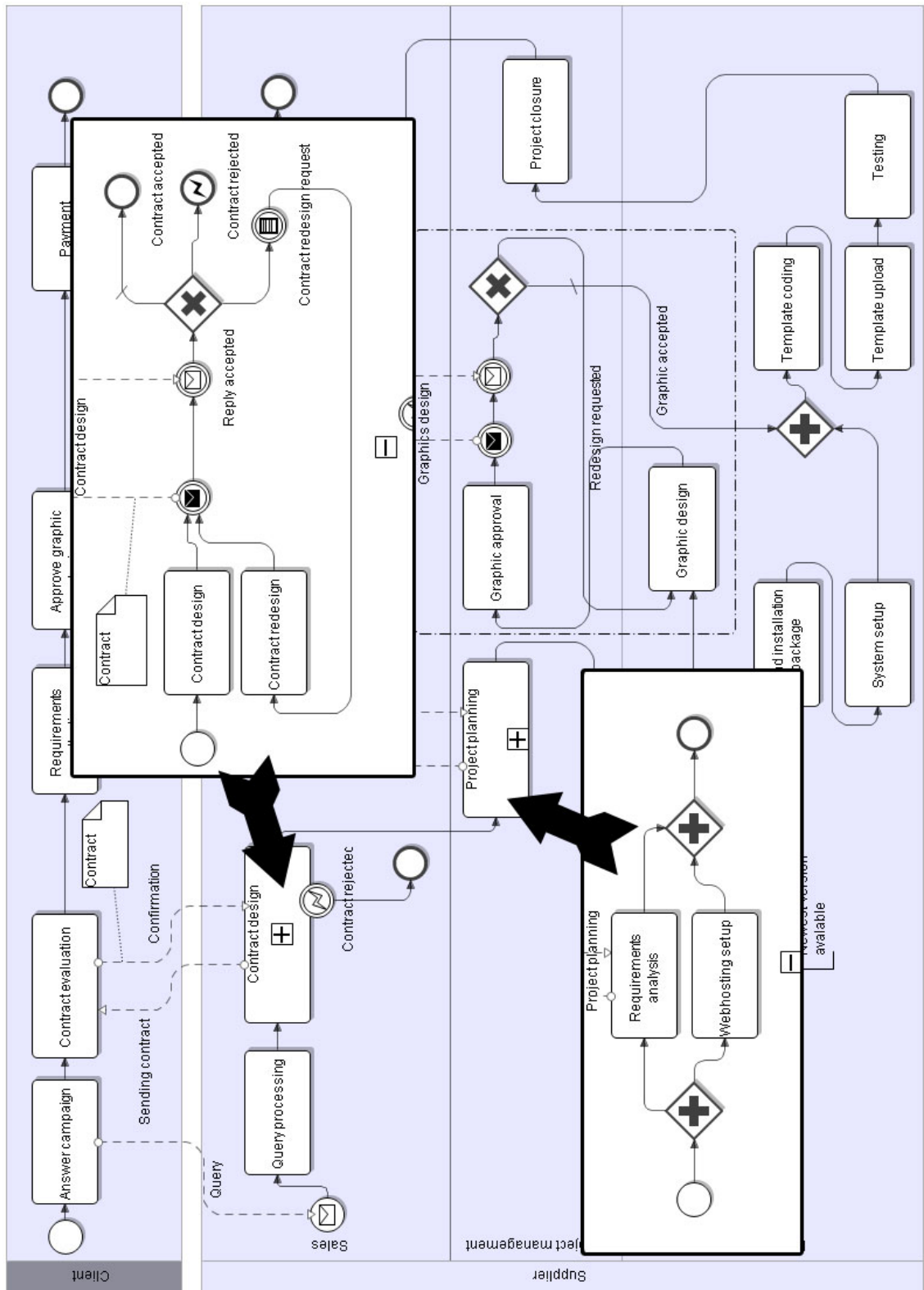

Image 43 – Business process diagram – expanded sub-processes

### 5.3.2.2 Contract design

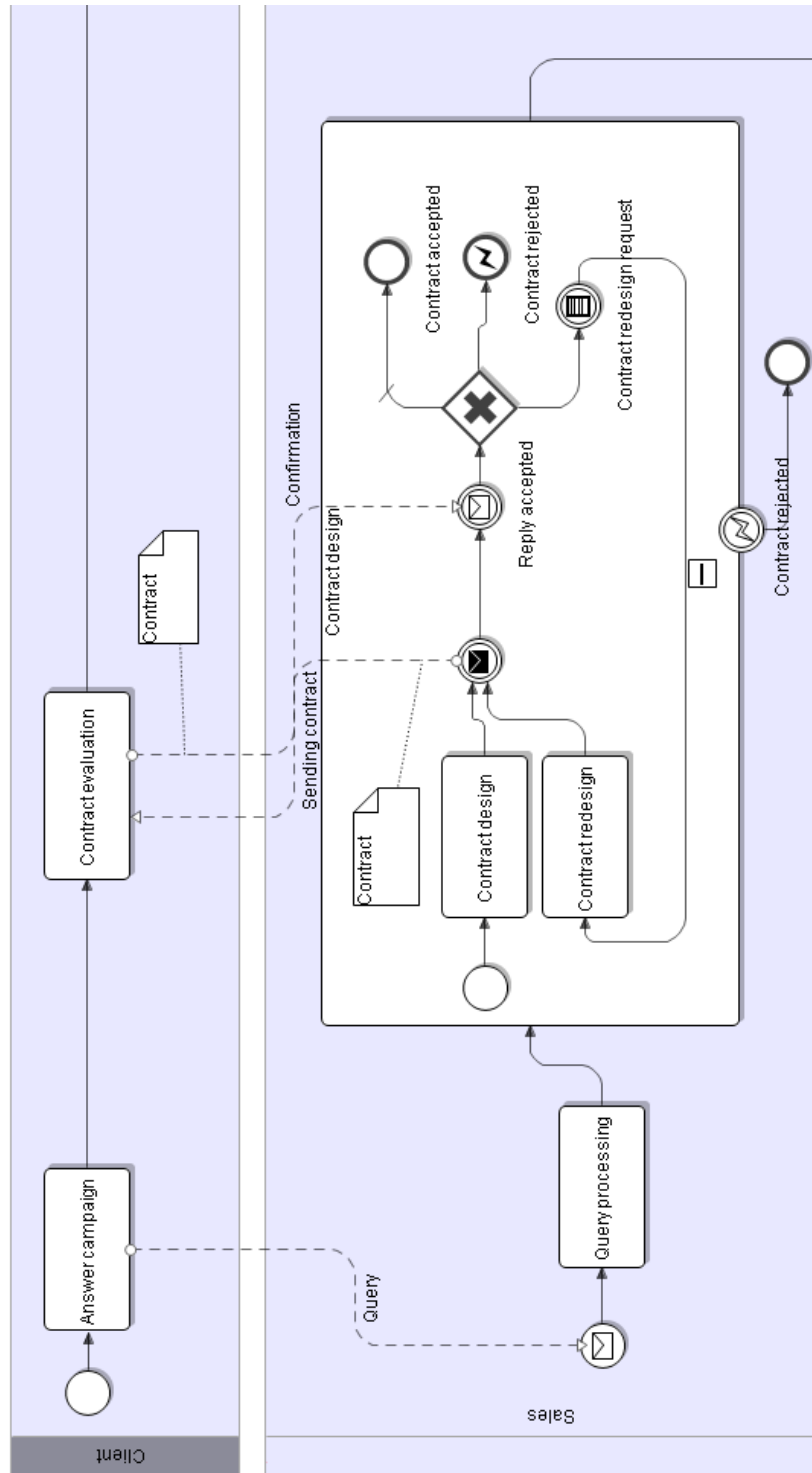
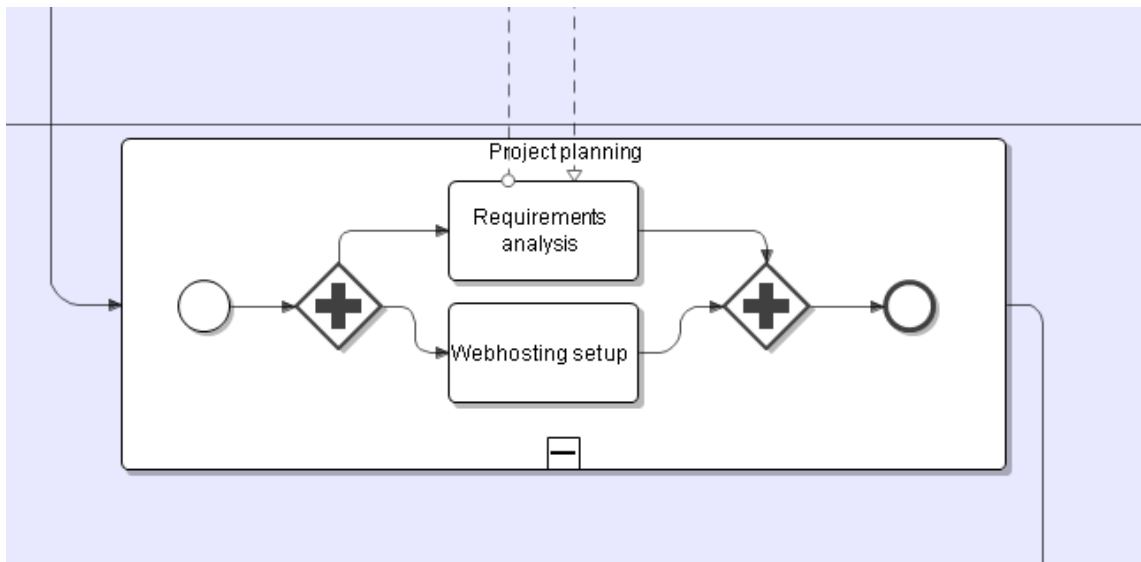

Image 44 – Contract design



Diagram block above shows the process flow within area of contract design and confirmation. There is also particular solution for situation in order to handle case of need of contract redesign. As is shown pool called client does communicate with pool supplier by lane sales which generally represents the process of real contract negotiations. There is also special type of error handling signed as flash. Solid border stands for throwing error and empty border signalise catching error that is all designed for ultimate state of rejected contract.

### 5.3.2.3 Project planning



**Image 45 – Project planning**

Project planning is divided into two main stages. First, it is needed to collect requirements for functional configuration of the solution and also it is possible to prepare the webhosting service for the solution. As it is meant for middle size organizations with average site traffic it is enough to use webhosting provider instead of server hosting. As is shown for the fork is used the parallel gateway which also handle synchronization. This view is in form of expanded subprocess while the minimal view would be shown as collapsed single activity.

#### 5.3.2.4 Graphics design and parallel activities

Following part of business process diagram of open source electronic commerce solution implementation shows the actual procedure when it comes to user interface design, additional redesign and graphic design approval and confirmation. Graphic design is very important part of usability of application so that it should not be underestimated at all as well as there is a need to produce accesible interface. Such accesible interface is strictly connected right to graphic lay out thus graphic design. The procedure is in real process a bit more complicated, but it is enough for demonstration in this paper.

Communication between client and supplier can be realised through images via e-mail or by links to extranet application of the supplier. Such a connection to external network of the enterprise can be even secured by authentication or another security integration. The main concept is to provide customer with suitable channel for decision making and also establish such conditions excluding any errors while transferring data.

There are several more activities possible to execute within development lane of supplier pool while processing the development of graphic design. Those activities such upload of actual version of open source e-commerce solution and its setup can be executed while developing graphic design because the essential instalation and setup do not vary according to particular solution chosen.

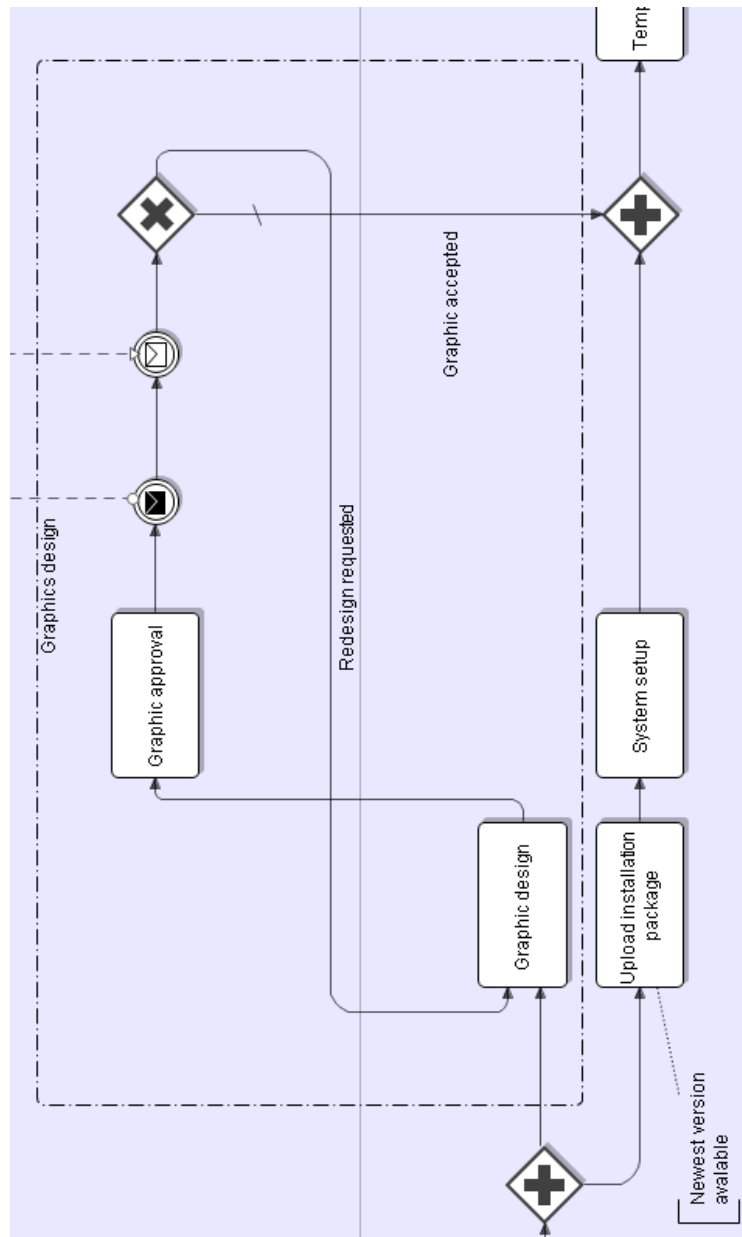

**Image 46 – Graphics design**

### 5.3.2.5 Template coding and testing

The next stage of the implementation of open source e-commerce solution is coding of HTML template and its upload to installed solution. It is possible to begin with testing when template uploaded.

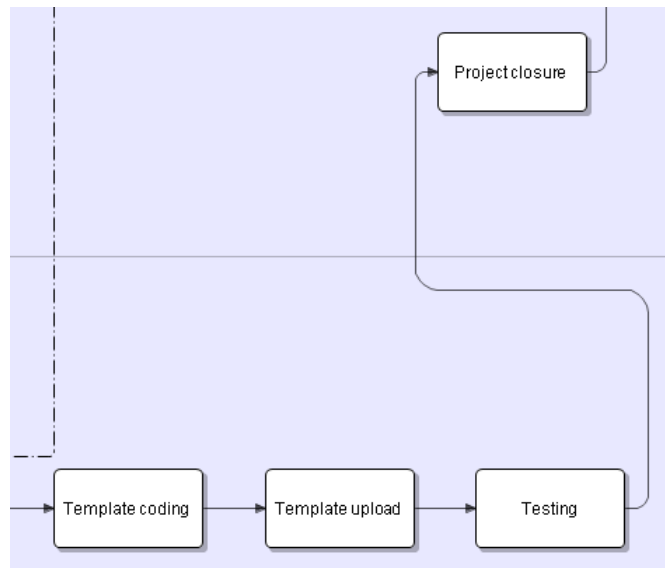

**Image 47 – Template coding and testing**

#### 5.3.2.6 Project closure

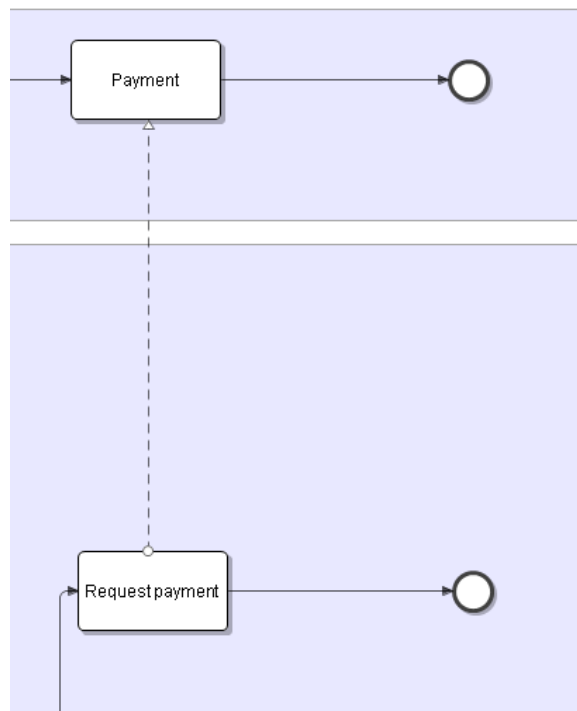

**Image 48 – Project closure**

There is shown that abstract and private processes end up more or less simultaneously and the business process diagram is here being finished. Payment request and payment

processing on the other side is the mandatory activity in order to successfully achieve requested business performance as well as to provide business functionality. After this stage the client is supposed to fill in the database of the products or services and execute the promotion of the solution.

As is shown the processes are ended up with end event which is in the form of circle with solid border. After this point there is no more activities allowed to be executed within either diagram or pools and lanes anymore. The business process is here being completed.

## 6 Conclusions

It was achieved to provide reader with exact information on business process management approach in the first part. It was also achieved to prove the significant progress in the area of modeling within computer aided system engineering. As thesis showed the convergence of e.g. UML and other methodologies into BPMN is also significant. Especially modeling of business processes and particular process related tools made tremendous move since business process management paradigm has seen the lights of industry environments. It is now main stream of focus of vendors in order to rise up their return of investment within object related architectures. Modeling of business processes also become very important from the point of view of industry standards organisations like Object Management Group and professional leadership was provided on development of business modeling standards. It is mandatory to mention nothing would have changed without major software and hardware vendors.

In the second part it was also managed to provide reader with particular overview of information on business process modeling paradigm, and the particular notation with its core elements was also introduced in the second part. This thesis has also shown that there is a strong tense of convergence within industry standards these days. Business process management notation started off nothing but became one the best future related standards whatsoever. Nevertheless there is still huge piece of work awaiting for the development of the standard itself through e.g. confusing situation around mappings of graphical notation into executable markup language or just executable language at all.

Business process diagram created within community modeling tool was designed for implementation of open source e-commerce solution in business process modeling notation. After this experience it is possible to subjectively state that business process modeling notation is intuitive enough to provide business analytics, developers and all other staff with suitable tools for unified and standardized communication. Introduction of BPMN within organisation is meant to be positive gain either for staff or management, but the biggest income it surely brings into improvement of business results.

As authors ultimate conclusion can be stated that either business process management approach or business process modeling notation are in the rush development and they will gain even more users within business environment while acquiring more and more global companies.

## 7 Bibliography

1. WESKE, Mathias. *Business process management*. First Edition. New York: Springer, 2007. 368 pages. ISBN 3540735216, 9783540735212.
2. BRIOL, Patrice. *Business process modeling notation*. First Edition. Lulu.com, 2008. 124 pages. ISBN 1409202992, 9781409202998.
3. Object Management Group/Business Process Management Initiative. *Business process modeling notation 1.1: OMG specification*. [online] February, 2008 (PDF 3,372K) [cit. 2010-03-02] Available from: <[http://bpmn.org/Documents/BPMN\\_1-1\\_Specification.pdf](http://bpmn.org/Documents/BPMN_1-1_Specification.pdf)>.
4. VESELY, Arnost. *Operating systems II*. Second edition. Prague: Czech University of Life Sciences Prague, Faculty of Economics and Management: 2006. ISBN 80-213-1553-9
5. REPA, Vaclav. *Business processes*. First edition. Prague: Grada:2005. ISBN 80-247-1281-4
6. MULLER, Gerit. *What is a process?* [online]. Version 3.0. [Eindhoven (Holland)]: Embedded Systems Institute, February 2008 [cit. 2010-03-02]. Available from: <<http://www.gaudisite.nl/WhatIsAProcessPaper.pdf>>.
7. TIZIANA, Margarie. BERNHARD, Steffen. *Continuous model-driven engineering*. IEEE internet computing. October 2009 [cit. 2010-03-02]. 0018-9162/09. Available from: <<http://www.computer.org/internet>>.
8. BPM.com. *BPM portal*. [online] 2010 [cit. 2010-03-02] Available from: <<http://www.bpm.com>>



## **III. Appendix**

# 8 Supplements

## 8.1 List of tables

Table 1 - Pools .....	- 69 -
Table 2 - Lanes – supplier pool.....	- 70 -
Table 3 - Activities.....	- 72 -

## 8.2 List of images

Image 1 – ARIS model (aris.com 2010) .....	- 21 -
Image 2 – Continuous model-driven engineering [7] .....	- 32 -
Image 3 – OMG.org .....	- 34 -
Image 4 – Example of private business process (OMG.org 2010).....	- 38 -
Image 5 – Example of an abstract business process (OMG.org 2010).....	- 39 -
Image 6 - Example of a collaboration business process (OMG.org 2010).....	- 40 -
Image 7 – Event element (OMG.org 2010) .....	- 43 -
Image 8 – Activity element (OMG.org 2010).....	- 44 -
Image 9 – Gateway element (OMG.org 2010).....	- 44 -
Image 10 – Sequence flow (OMG.org 2010).....	- 45 -
Image 11 – Message flow (OMG.org 2010) .....	- 45 -
Image 12 – Association (OMG.org 2010) .....	- 46 -
Image 13 – Pool element (OMG.org 2010) .....	- 46 -
Image 14 – Lane element (OMG.org 2010).....	- 47 -
Image 15 – Data object (OMG.org 2010) .....	- 47 -
Image 16 – Group (OMG.org 2010) .....	- 48 -
Image 17 – Text annotation (OMG.org 2010) .....	- 48 -
Image 18 – Extended event elements (OMG.org 2010) .....	- 49 -
Image 19 – Extended events – triggers (driveintobpm.org 2010).....	- 50 -
Image 20 – Example of throwing and catching event (driveintobpm.org 2010) .....	- 50 -
Image 21 - Collapsed sub-process (OMG.org 2010) .....	- 51 -
Image 22 – Expanded sub-process (OMG.org 2010) .....	- 51 -
Image 23 – Conditional flow (OMG.org 2010) .....	- 52 -

Image 24 – Default flow (OMG.org 2010) .....	- 52 -
Image 25 – Exception flow (OMG.org 2010).....	- 52 -
Image 26 – Example of interruption within process (driveintobpm.org 2010).....	- 53 -
Image 27 – Compensation association (OMG.org 2010) .....	- 53 -
Image 28 – Gateway control types (omg.org 2010).....	- 54 -
Image 29 – Data-based gateway within process (driveintobpm.org 2010).....	- 55 -
Image 30 – Data-based gateway in Intalio Designer (Intalio.com 2010) .....	- 55 -
Image 31 – Event-based gateway within process (driveintobpm.org 2010).....	- 56 -
Image 32 – Example of parallel gateway (driveintobpm.org 2010) .....	- 56 -
Image 33 – Example of imclusive gateway (driveintobpm.org 2010).....	- 57 -
Image 34 – Inclusive gateway combined with parallel (driveintobpm.org 2010) .....	- 58 -
Image 35 – Example of complex gateway (OMG.org 2010).....	- 58 -
Image 36 – Sequence flow connection rules (OMG.org 2010) .....	- 60 -
Image 37 – Message flow rules (OMG.org 2010) .....	- 60 -
Image 38 – Intalio platform (intalioworks.com 2010).....	- 65 -
Image 39 – Soyatec eBPMN Designer (Soyatec.com 2010) .....	- 66 -
Image 40 – Gliffy.com (2010) .....	- 67 -
Image 41 – BizAgi Process Modeler (bizagi.com 2010).....	- 68 -
Image 42 – Business process diagram .....	- 74 -
Image 43 – Business process diagram – expanded sub-processes.....	- 75 -
Image 44 – Contract design .....	- 76 -
Image 45 – Project planning .....	- 77 -
Image 46 – Graphics design.....	- 79 -
Image 47 – Template coding and testing .....	- 80 -
Image 48 – Project closure.....	- 80 -