

4. component – 2 pieces (2x) – D

Material: WOOD

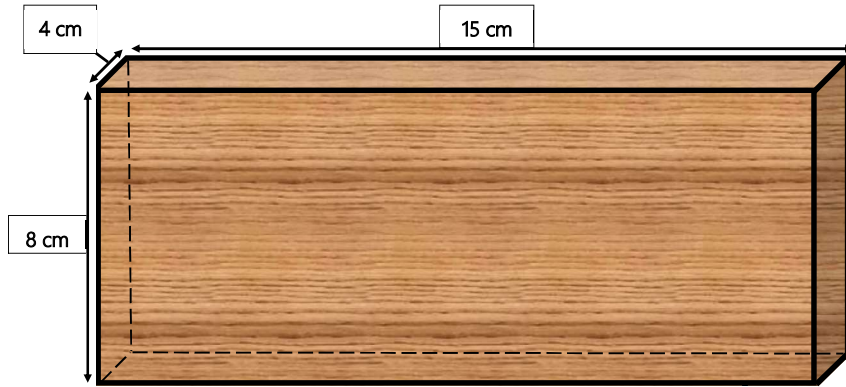

4

5. component – E

Material: WOOD

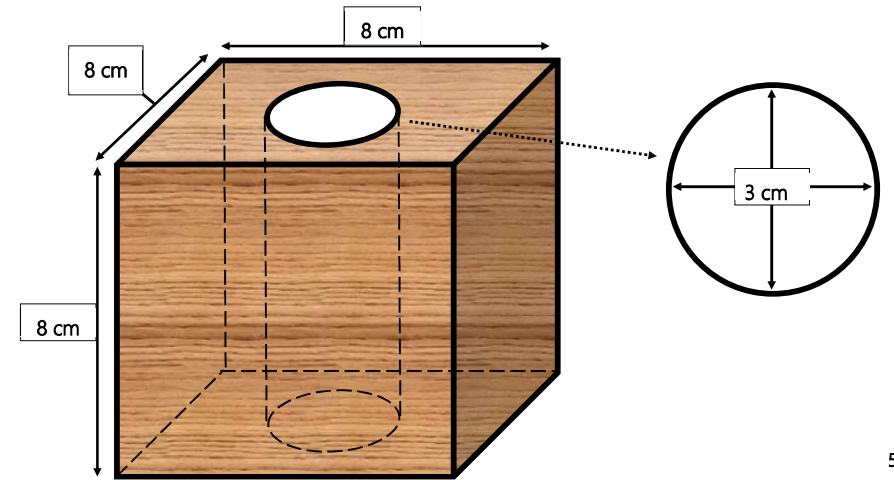

5

6. component – 2 pieces (2x) – F

Material: WOOD

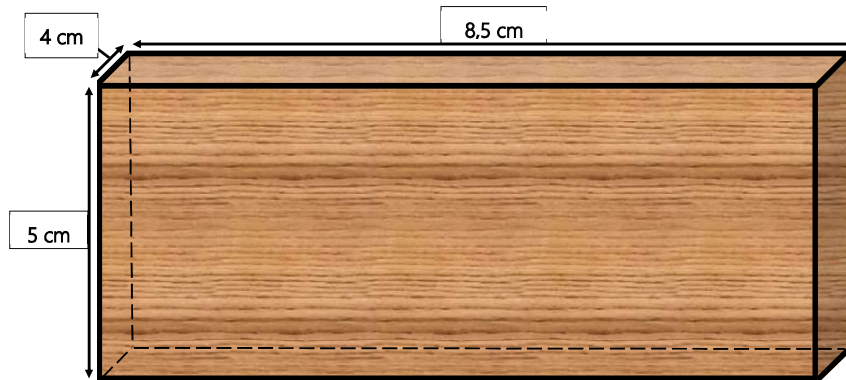

6

7. component – 2 pieces (2x) – G

Material: WOOD

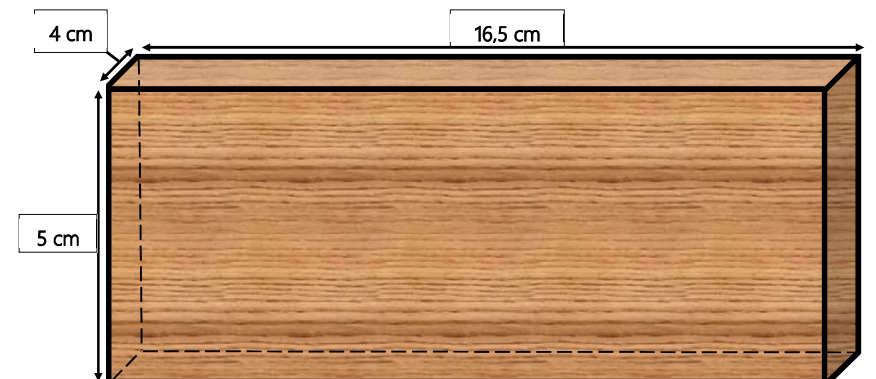

7

8. component – H

Material: WOOD

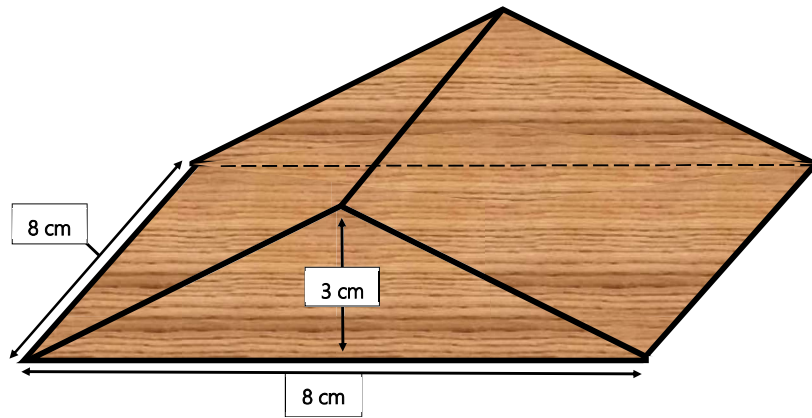

8

9. component – I

Material: WOOD

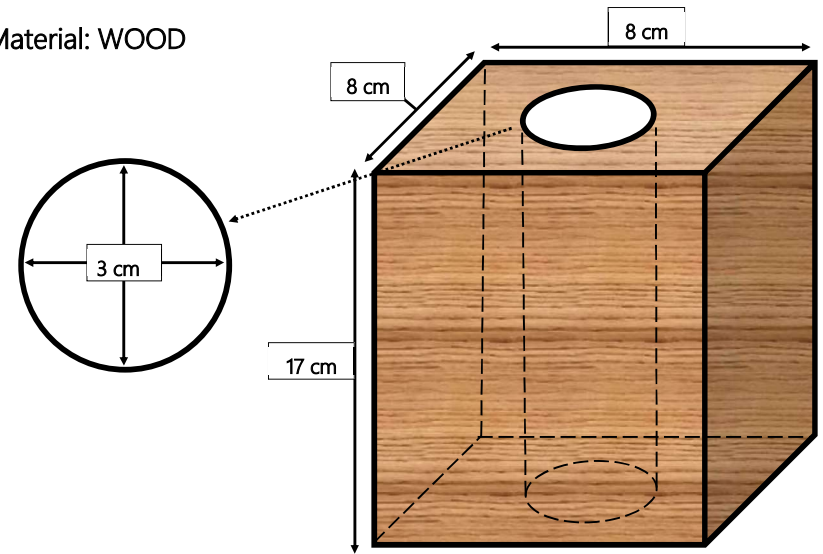

9

10. component – J

Material: WOOD

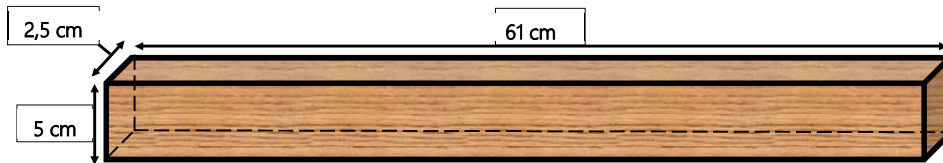

10

11. component - K

Material: WOOD

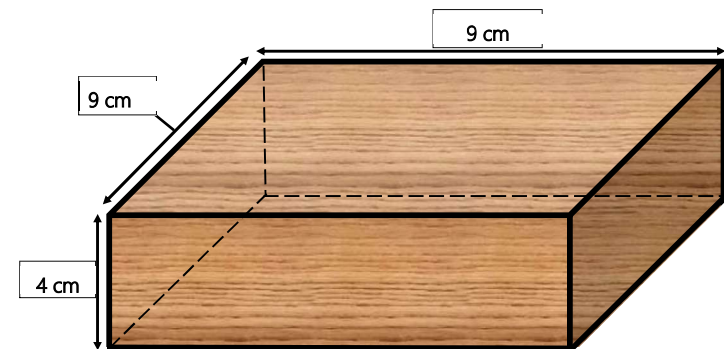

11

12. component – 2 pieces (2x) – L

Material: WOOD

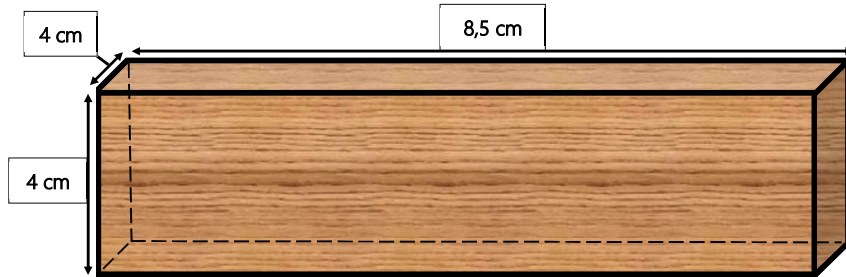

12

13. component – 2 pieces (2x) – M

Material: WOOD

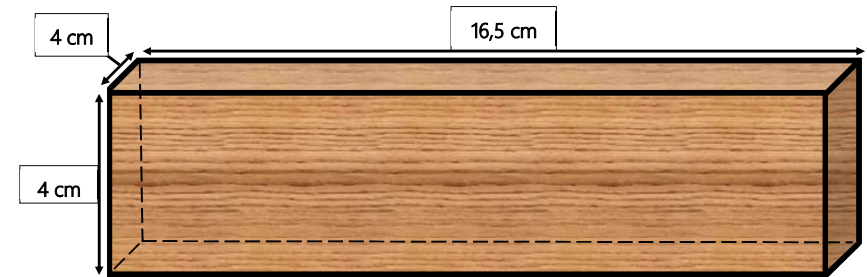

13

14. component – 22 pieces (22x) – N

Material: METAL

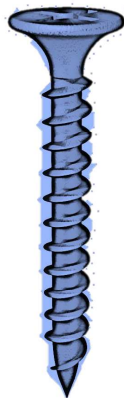

14

15. component - O

Material: METAL

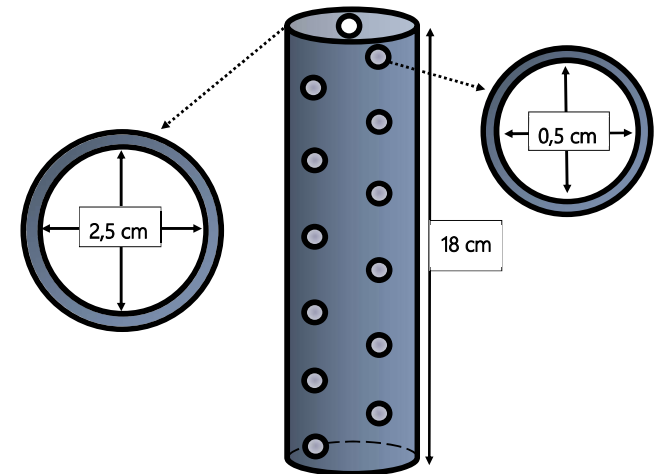

15

16. component – P

Material: METAL

