



BRNO UNIVERSITY OF TECHNOLOGY

VYSOKÉ UČENÍ TECHNICKÉ V BRNĚ

FACULTY OF ELECTRICAL ENGINEERING AND COMMUNICATION

FAKULTA ELEKTROTECHNIKY
A KOMUNIKAČNÍCH TECHNOLOGIÍ

DEPARTMENT OF FOREIGN LANGUAGES

ÚSTAV JAZYKŮ

BUILDING MANAGEMENT SYSTEM

ŘÍDÍCÍ SYSTÉM BUDOV

BACHELOR'S THESIS

BAKALÁŘSKÁ PRÁCE

AUTHOR

AUTOR PRÁCE

Daniel Kunický

SUPERVISOR

VEDOUCÍ PRÁCE

PaedDr. Alena Baumgartnerová

BRNO 2016



Bakalářská práce

bakalářský studijní obor **Angličtina v elektrotechnice a informatice**

Ústav jazyků

Student: Daniel Kunický

ID: 159184

Ročník: 3

Akademický rok: 2015/16

NÁZEV TÉMATU:

Řídící systém budov

POKYNY PRO VYPRACOVÁNÍ:

Obeznamit se se systémem MaR v aplikacích při řízení technologických zařízení budov.

Rešerše literatury o systému měření a regulace.

Identifikace úrovní projektu.

Praktická realizace návrhu řízení.

DOPORUČENÁ LITERATURA:

BENEŠ, Pavel. Automatizace a automatizační technika: prostředky automatizační techniky. 5., rozš. a aktualiz. vyd. Brno: Computer Press, 2014, 304 s. ISBN 978-80-251-3747-5.

<http://www.cs.berkeley.edu/~culler/cs294-f09/m197content.pdf>

Termín zadání: 11.2.2016

Termín odevzdání: 27.5.2016

Vedoucí práce: PaedDr. Alena Baumgartnerová

Konzultant bakalářské práce: ing. Tomáš Lasek

doc. PhDr. Milena Krhutová, Ph.D., předseda oborové rady

UPOZORNĚNÍ:

Autor bakalářské práce nesmí při vytváření bakalářské práce porušit autorská práva třetích osob, zejména nesmí zasahovat nedovoleným způsobem do cizích autorských práv osobnostních a musí si být plně vědom následků porušení ustanovení § 11 a následujících autorského zákona č. 121/2000 Sb., včetně možných trestněprávních důsledků vyplývajících z ustanovení části druhé, hlavy VI. díl 4 Trestního zákoníku č.40/2009 Sb.

Abstract

This paper provides an insight into the building management system and its design. Building management system is represented in many modern buildings ranging from family houses to research centres. This system is able to ensure significant savings on energy and is also responsible for the comfort and safety of inhabitants.

Keywords

Building management system, HVAC, sensor, control, direct digital control, programmable logic controller, project documentation

Abstrakt

Tato práce umožňuje náhled do systému měření a regulace a jeho projektování. Systém měření a regulace je součástí mnoha moderních budov od rodinných domů až po výzkumná střediska. Tento systém je také schopen zajistit významné úspory na energiích a má také na starosti komfort a bezpečí obyvatel.

Klíčová slova

Měření a regulace, HVAC, senzor, řízení, DDC, programovatelný logický automat, projektová dokumentace

Prohlášení

Prohlašuji, že svou bakalářskou práci na téma Building management system jsem vypracoval samostatně pod vedením vedoucího bakalářské práce a s použitím odborné literatury a dalších informačních zdrojů, které jsou všechny citovány v práci a uvedeny v seznamu literatury na konci práce.

Jako autor uvedené bakalářské práce dále prohlašuji, že v souvislosti s vytvořením této bakalářské práce jsem neporušil autorská práva třetích osob, zejména jsem nezasáhl nedovoleným způsobem do cizích autorských práv osobnostních a/nebo majetkových a jsem si plně vědom následků porušení ustanovení § 11 a následujících zákona č. 121/2000 Sb., o právu autorském, o právech souvisejících s právem autorským a o změně některých zákonů (autorský zákon), ve znění pozdějších předpisů, včetně možných trestněprávních důsledků vyplývajících z ustanovení části druhé, hlavy VI. díl 4 Trestního zákoníku č. 40/2009 Sb.

V Brně dne

.....

(podpis autora)

KUNICKÝ, D. *Řídicí systém budov*. Brno: Vysoké učení technické v Brně, Fakulta elektrotechniky a komunikačních technologií, 2016. 48 s. Vedoucí bakalářské práce PaedDr. Alena Baumgartnerová.

Contents

INTRODUCTION	8
1 HEATING, VENTILATION, AIR-CONDITIONING	9
1.1 Heat sources	11
1.1.1 Solid fuel boiler, fireplace	11
1.1.2 Solar collector	12
1.1.3 Electric boiler	12
1.1.4 Gas boiler	12
1.1.5 Heat pump	13
2 PERIPHERAL LEVEL	14
2.1 Sensors.....	14
2.1.1 Temperature sensor	14
2.1.2 Twilight sensor	16
2.1.3 Gas leak detector	16
2.1.4 PIR sensor	16
2.1.5 Air quality sensor	17
2.1.6 Consumption meters.....	18
2.1.7 Pressure sensor	18
2.2 Actuators	19
2.2.1 Variable Frequency Drives.....	19
2.2.2 Damper actuators.....	20
3 AUTOMATION LEVEL	21
3.1 Direct Digital Control (DDC).....	21
3.2 Programmable Logic Controller (PLC).....	22
3.3 Communication protocols	24
3.3.1 BACnet.....	24
3.3.2 Modbus.....	25
3.3.3 LonWorks.....	25
4 OPERATOR LEVEL	26
4.1 SCADA	26
4.2 HMI.....	27

5	PROJECT DOCUMENTATION	28
5.1	Textual part.....	29
5.2	Drawing part.....	29
6	PRACTICAL CASE.....	32
6.1	Project.....	32
6.1.1	Technical report.....	33
	CONCLUSION	44
	LIST OF FIGURES	45
	LIST OF TABLES	46
	LIST OF APPENDICES	47
	LITERATURE	48

Introduction

Building management system is a very complex field of study. This system is closely related to the control theory, automation in buildings and industry, and last but not least intelligent houses. The increasing cost of energy, the emphasis on security and the vulnerability of buildings to fire are in favour of automation processes that are perfectly controlled by building management system. It supervises, monitors and integrates building utilities such as heating, ventilation, air conditioning (HVAC), air quality, lighting, security, and fire suppression. The most common function of the BMS is the control of HVAC system which includes air handling units, chilled water plants, cooling towers, tenant water condensers, heating water plants, exhaust systems, etc. Roles of a BMS designer is to analyse the requirements of the authority, perform necessary steps in planning, and design the project documentation. All the utilities mentioned above are executed by people with specific knowledge of the exact system. Building management system also includes real-time monitoring, trending and logging of building operation and performance, time scheduling of building systems, fault management, alarming, and energy management. For the most effective control, we are measuring physical quantities such as temperature, humidity, pressure, flow, light and other measurable quantities, for instance, the level of liquid/bulk materials in reservoirs, movement of objects and chemical properties of gasses/liquids. The building control applications include zone temperature monitoring and control, zone CO₂ monitoring and control, control of temperature, airflow, pressure within air handling units, exhaust fan control, and the building control after operation hours.

1 Heating, Ventilation, Air-Conditioning

The comfort of the inhabitant is proportional to the temperature in the room, therefore, we need to choose an appropriate heating system. When the inappropriate heating system is chosen, the significant losses occur. There are usually local heaters used (e.g. stoves, fireplaces, gas heaters, etc.) in small apartments or cottages. Buildings that are significantly larger are equipped with the central heating system. The energy for the heating is acquired from several kinds of sources: electricity, heat pump, natural gas, liquid fuels, coal and renewable energy sources. There are several government regulations that control the optimal temperature in the rooms. For example, Decree no. 93/2012 amending Decree no. 361/2007 is defining conditions for workplace safety and health. Outdoor weather conditions are said to be extraordinary when the temperature is -15°C or $+30^{\circ}\text{C}$. Type of the heating furnace depends on the calculations of the heat losses. These calculations compute with the average outdoor temperature in the region, but the real temperature is often different, thus the heat created by heating device needs to be properly handled. Therefore, the heating regulation is needed.

The individual room control (IRC) is used when the temperature is needed to be different in each room, for example, the living room has different temperature program than the bathroom or machine room. There must be a temperature sensor in every controlled room and the heating or cooling device. Then the opening/closing of heating and cooling device is based on the difference between the set temperature and the actual room temperature. The IRC is able to react on the other heat sources such as sun, fireplace, stove, etc. so it does not overheat or overcool room, thus it saves the energy and money.

The heat can be regulated in many different ways and the type of regulation depends on the distribution of heat. In the case of small objects heated with water, the most used are thermostatic valves. These valves are able to control the heat and keep the set temperature in the room regardless of the occurrence of occupants. Every heating device should be equipped with the thermostatic head. These heads can be both manual and automatic. Manual thermostatic heads can be fitted with or without the display – this depends on the exact requirement of the owner. Automatic heads are actuated by the signal from a room thermostat. To ensure the proper temperature, the signal from the thermostatic head has to be compared with the signal from the temperature sensor. Manual heads are dependent only on the inhabitant feelings. It is important to mention that automatic heads can save up to 30% on heating costs.



Figure 1. Manual and Automatic thermostatic head (taken from fonetip.cz)

In terms of HVAC the heating is more often provided by the heated air. While the heated air is used, the duct system is common for both heated and cooled air from the air-conditioning unit. The temperature of the air is controlled by the air handling units, and the airflow is controlled by damper actuators. The damper actuator can be either analogue or digital. The analogue means that the dampers can be set into various positions unlike the digital which can only be either opened or closed. There are also used differential pressure switches for better fault control. When the fans or dampers stop working, the pressure in a duct rapidly increases and the pressure switch reports an error.

The air-conditioning system was mainly constructed for maintaining suitable humidity and adequate ventilation. The government of the Czech Republic published the hygiene regulations to ensure the healthy environment and suitable ventilating and air-conditioning conditions. Proper use of AC leads to effective removal of microorganisms, dust, and other foreign bodies from the air. It can also help the heating system to preheat rooms quickly. The AC is used for the air adjustment and its distribution. Processes such as heating, cooling, humidification, dehumidification and filtration of air are done in the specialized components within the ventilation system. The air is driven to its destination by the system of fans. Important parts of the ventilation system are air filters. They are filtering the air during the exchange. There are several risks when the air-conditioning unit is not built properly. The air-conditioning system has to be handled with proper care to avoid negative consequences. The main components are usually placed in the special room so-called machine room.

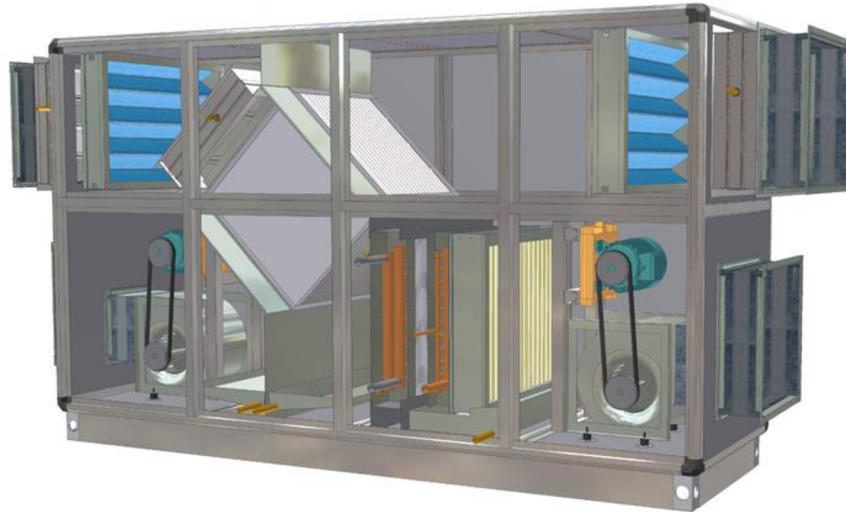

Figure 2. Example of air handling unit (taken from lufberg.com)

In the right and left corner of the picture can be seen fan units with the motors. These motors drive fan blades. The rotational speed and torque of fan blades are controlled by the variable-frequency drives that are changing the motor input frequency and voltage. Their initial investment cost is quite high, but the following savings are much higher. The rectangular unit in the centre of the picture is called heat recovery unit, which is used to cross flow between inbound and outbound air to preheat or precool inbound air. The efficiency of heat recovery units can be up to 90-95%.

1.1 Heat sources

In terms of acquiring heat, it can be stated that there exist several different heat sources and different methods of controlling them.

1.1.1 Solid fuel boiler, fireplace

Modern boilers are equipped with their own controllers, so there is no need to control them by BMS. However, the older ones are not equipped with any controller, thus it is necessary to control the combustion air entering the boiler and the temperature of the return water. These are the main problems of any kind of boiler. Fireplaces are commonly used for more pleasant thermal comfort. If the fireplace is used as a heating device, it is usually equipped with the manufacturer's autonomous controller. On one hand, the fuel price is the lowest on the market, on the other hand, their control is rather complicated.

1.1.2 Solar collector

The solar collector is the ideal solution as a secondary, eventually primary, heat source for heating systems, swimming pool heating, and preheating of domestic hot water. This device is most active during summer months. Nevertheless, it is active even during winter, spring, and autumn. The main disadvantage is that the energy must be consumed even when it is not needed. The solution for that is the use of accumulation tank (it is useful even with the solid fuel boilers). We can heat the accumulation tank enough to produce heat for a few days – it depends on the tank and the ability of the boiler to heat it up. Solar collectors are a source of free energy.

1.1.3 Electric boiler

The high-power boilers are usually equipped with the controller, but low-power boilers are not equipped with any controller according to the preservation of the lowest price. The regulation of an electric boiler is divided into primary and secondary regulation. The primary regulation principle is based on the gradual switching of heating spirals to reach the wanted value of the output hot water. The use of pulse-width modulation of heating spirals is the secondary and more effective solution. The principle is similar to the primary regulation, but instead of turning the heating spiral on fully, the last switched spiral is continuously regulated between 0-100%. After the spiral reaches 100% of its power, next spiral is turned on. Electric boilers are one of the most expensive heat sources. Their usage is suitable when there is no possibility to apply different kind of fuel.

1.1.4 Gas boiler

Gas boilers can be divided according to their power. The lowest one can be further divided into two subsections: one with static power, which means it is working on the on /off principle, and the other one with continuously regulated power. The worst thing to do with the boiler burner is its constant on/off work. Not only does this mode reduce the service life of boilers, but it is also very uneconomical. Boilers with continuously regulated burners have the inner controller that automatically sets the exact power according to the output temperature of hot water. The typical range of power is between 20% and 100%. Modern boilers are equipped with the electronic unit, through which boiler can be controlled by the unified signal 0-10V. High power boilers are usually using the unified signal 0-10V. Medium power boilers can be single-stage, two-stage or multistage. Single stage is on/off and two-stage is 0/70%/100%.

1.1.5 Heat pump

The operation of a heat pump is based on the reversed Carnot cycle. They are absorbing low-grade heat from the water, air or ground, and releasing that heat to heating devices. Operating costs are much lower, compared with the traditional methods, but there must be applied an appropriate solution and reasonable usage. Heat pumps are not suitable for long-term heating. They are suitable for underfloor heating and preheating of hot domestic water or for cooling during summer, but they usually serve as support devices for gas/electric boilers. The coefficient of performance is one of the monitored values and should be higher than 1. It is the ratio between used electrical energy and distributed thermal energy. Heat pumps are equipped with their own control unit. BMS enables their operation (summer/winter modes) and deals with the fault indication.

2 Peripheral level

2.1 Sensors

Many different kinds of sensors are used in the building management system. Components that are mentioned in this chapter are selected on the basis of the personal experience with them.

2.1.1 Temperature sensor

Temperature is one of the most measured physical quantity along with mass, time and length. It is a physical quantity expressing the degree of the thermal state of the body. Heat is a form of energy which has its origin in the disordered movement of elementary particles. To be accurate, heat is defined as a heat energy or heat capacity because of the terms such as heat energy transfer or heat capacity transfer (1). Measuring of the temperature is one of the most important disciplines because many technological processes rely on it. We can divide temperature sensors into two basic groups, which are described below, and then into the resistance, semiconductor and thermocouple sensors.

Contact temperature sensor types

These sensors use conduction to monitor changes in temperature, which means they are required to be in physical contact with the measured object. They are used to measure the temperature of solids, liquids or gasses.

Non-contact temperature sensor types

Unlike the contact sensors, these use convection and radiation to monitor changes in temperature. They are used to detect emitted radiant energy of liquids and gasses or the radiant energy that is emitted by the measured object in the form of infra-red radiation.

Resistance sensors

The most used type of temperature sensors are the resistance sensors which can be divided into several groups: according to the type of material (metallic – Pt, Ni, Cu; semiconductor – NTC, Si, Ge), the range (low temperatures -200~100°C, room temperatures -30~100°C, lower middle temperatures -50~650°C, higher middle temperatures 0~1000°C) or the type of body and usage (4). One of the important attributes of temperature sensors is their temperature coefficient which is defined as mean relative resistance over one degree of Celsius, in the range from 0 to 100. It can be either positive or negative.

Pt sensors

The sensors made of platinum are characterized by their short time response, great thermal stability, small dimensions, resistance against vibrations and thermal shocks, and the high reliability. They are made in three types which are given by their input resistances: Pt 100, Pt 500, and Pt 1000 (4).

Ni sensors

The construction of both sensors is identical except the material, which is Nickel. Also, both of the sensors have common properties such as short time response, great thermal stability, etc. The input resistance of these sensors starts on 891 Ohms continues with 1000 and ends with 2226 Ohms.

NTC thermistors

They are composed of semiconductor material (oxides of Fe, Mn, Co, Ni and other metals) that has been sintered in order to display large changes in resistance in proportion to small changes in temperature. NTC thermistors are non-linear resistors – with decreasing temperature is their resistance increasing (5), which means that they have a negative temperature coefficient.

Thermocouples

The thermocouple is a simple, widely used component for measuring temperature. A thermocouple consists of two wires, shown in figure 4, of dissimilar metals joined together at one end, called the measurement junction. The other end, where the wires are not joined, is connected to the signal conditioning circuitry traces. This junction is called reference junction. The voltage produced depends on the temperatures at both the measurement junction and the reference junction (6). The composition and properties are defined by the standards EN 584 or ČSN 60584 (4).

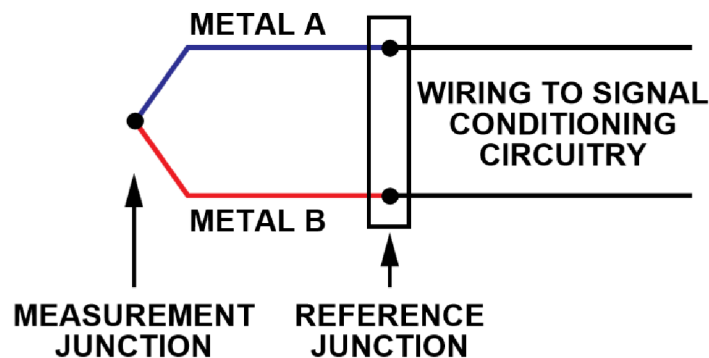

Figure 3. Diagram of the thermocouple sensor (taken from analog.com)

2.1.2 Twilight sensor

Twilight sensor analyses the intensity of light in its surrounding. If the intensity drops under a set value, the sensor switches the connected lights on. When natural light returns, the sensor switches the lights off. On and off actions have a delay to avoid faulty operation when the temporary dark/light occurs, it is approximately a few minutes. The faulty operations could be caused by the car headlights, lighting, etc. Another type of sensor with similar function, but opposite action, is used to control window blinds.

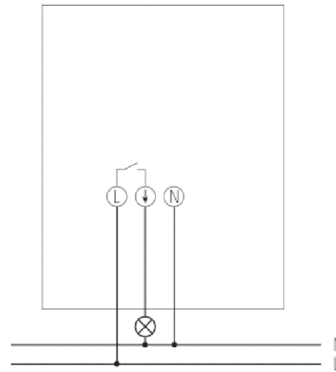

Figure 4. Simple twilight sensor (taken from theben.de)

2.1.3 Gas leak detector

Modern gas leak detectors are operating in two stages. The first stage is turned on when the concentration of flammable gasses crosses 10% limit. The BMS system deals with the alert, thus it should run emergency fans to ventilate the room (if there are no ventilation, authorized personnel should open windows). The second stage is on at 20% limit – this limit is dangerous and can be harmful. BMS turn off the boiler or close the electrically controlled valve on gas supply, turn on the ventilation, signalisation, and optionally horn. The gas leak detector should be located on the ceiling, or in the case of propane butane on the floor because it is heavier than air.

2.1.4 PIR sensor

The Passive InfraRed sensor is closely connected to the lighting control. Unlike the twilight sensors, these sensors are rather complicated and their proper function depends on many factors (unwanted motion of pets, unwanted activity during a daylight, etc.). The IR sensor is detecting the change in motion between two points which are characterized by two slots on IR sensor (figure 5).

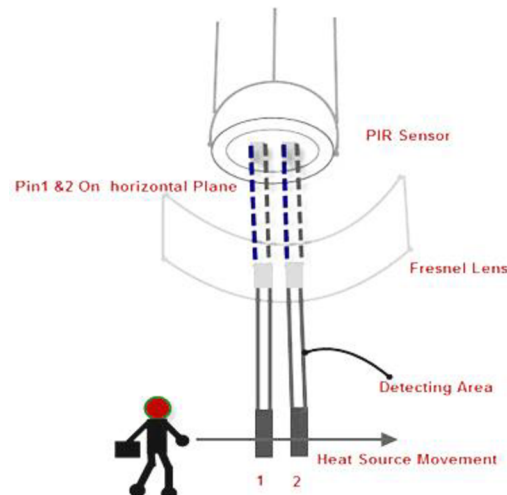

Figure 5. How the PIR sensor works (taken from elprocus.com)

The first pin generates the positive and the second pin generates negative energy which is converted into electric pulses high enough to activate the transistor inside and deliver the signal to the control system.

2.1.5 Air quality sensor

Poor air quality in buildings can negatively affect the health of the inhabitants. These sensors are measuring the concentrations of gasses in rooms, or ventilations, which means that it can recognise smoke or the gas leak. It can be designed only to sense CO₂ or even the leaking flammable gasses and volatile organic compounds (VOC). Modern sensors have the ability to sense relative humidity in the rooms. They are used in party rooms, lounges, exhibition halls, restaurants, shopping malls, and any crowded place. They are also used in machine rooms, heating rooms and storages with gas bombs, etc. Some air quality sensors can serve as a safety device, for example, gas or smoke warning devices. The example of the air-quality sensor can be a sensor QPA10xx or QPA20xx by the Siemens AG. The example of air-quality measurement in the family house is shown in figure 6.

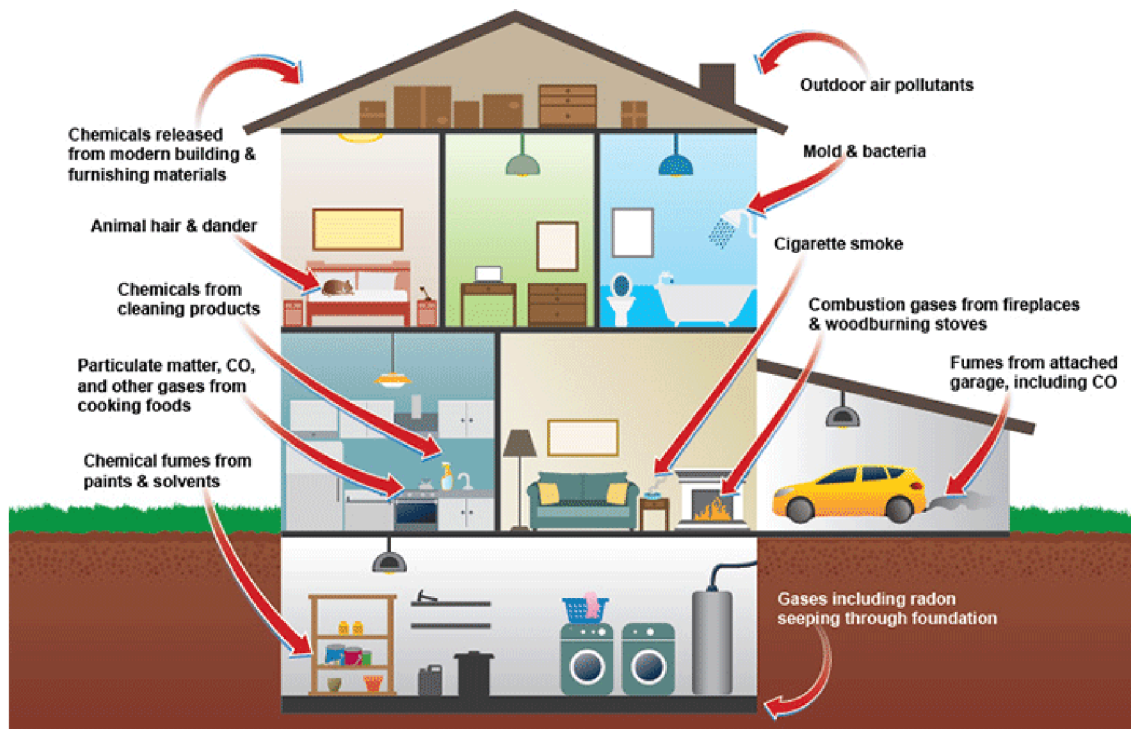

Figure 6. Example of air quality measuring (taken from quantifiedbob.com)

2.1.6 Consumption meters

BMS is also dealing with the measuring of consumptions in terms of water, gas and heat. Every modern meter should have the ability to transmit measured data through the communication protocol to the PLC or DDC. It is done via the, for example, M-Bus, Modbus, BACnet, etc. To prevent customers from the consequences of incorrect measurements made in the field of official transactions, working conditions, public health and work safety, a Decree of Ministry of Industry and Trade sets the list of instruments for mandatory verification (8). The water meter use is required on every water connection by the Decree. Gas meters are used to measure the volume of gas. Gas meters and water meters operate on the similar principle due to the similar properties of these fluids. And of course, calorimeters are used to measure the heat flow in households, industries, etc.

2.1.7 Pressure sensor

Pressure sensors used in BMS can be divided by their operation and by the kind of a measured fluid. In terms of their operation, they are measuring pressure at one point, or pressure differences between two points. BMS also deals with the different kind of fluids, it can be either air, water, or any other fluid such as gas. The principle is similar, but their sensitivity depends on the measured fluid. Differential pressure sensors are used mainly in

ventilation shafts to acquire the information about fault conditions of filters, fans or heat exchangers. The basic principle of these sensors is in the measuring of differences before and behind. For instance, when the pressure behind filter differs from the pressure before filter, it means that the filter is clogged and needs to be replaced or cleaned.

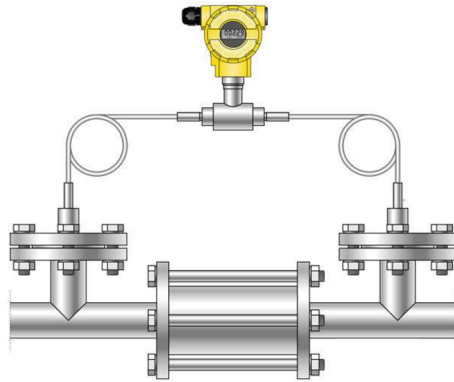

Figure 7. Example of the mounting (taken from directindustry.com)

2.2 Actuators

2.2.1 Variable Frequency Drives

A Variable Frequency Drive (VFD) is a type of motor controller that drives an electric motor by varying the frequency and voltage supplied to the electric motor. In short, the principle of VFD is in just three basic blocks. The first block is the converter consisting of diode bridge which converts AC to DC, next block is the capacitor which smooths the converted signal, and final block is the inverter consisting of transistors that change the DC back to AC and run the motor at particular rpm. The motor's rpm is proportional to the switching rate of the inverter (7).

VFDs are used with the motors of fans within the ventilation systems. Motors which have low power output are not usually connected with the VFD, but motors that have significantly larger power create surges in electrical grid during start up. VFDs can prevent these surges and any such impacts on the ventilation system. VFDs are decreasing the consumption of the electrical power, which leads to the decreasing operating costs. They can run fans at lower speeds during the night to decrease noise, and pre-heat/cold rooms during special tariffs.

2.2.2 Damper actuators

A damper actuator is a type of device that controls dampers of the ventilation system according to the needed airflow. There are several types of actuators that have slightly different properties.

Actuators can be divided into two groups, with the emergency control function or without emergency control function. Each group can be subdivided to rotary and linear motion actuators. The actuator motion is controlled by the operational voltage 24VDC or 230VAC. Emergency control function means when there is no electricity, due to the shunt or power outage, the flap position is either open or close.

3 Automation level

3.1 Direct Digital Control (DDC)

The DDC controllers are mostly used in HVAC systems. They are designed for specific tasks such as fan coil or heating unit control, thus there is no need to program the entire system. The system control is based on the digital controller or computer station and the software application (algorithm) stored in the memory of the controller. The example of the basic controller is shown below in figure 7.

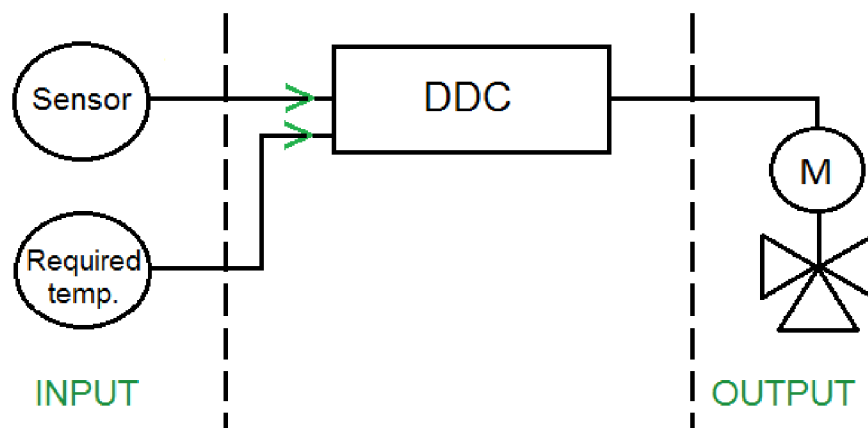

Figure 8. Simple diagram of DDC control (taken from tzb-info.cz)

Imagine that we are measuring temperature and the heating device is HVAC. The room temperature is set to be 25°C. There is an algorithm that is comparing the required temperature with the temperature from the sensor. The resulting signal then opens or closes the three-way mixing valve through which the heating medium flows to the heating device. As long as the sensor temperature is higher than required temperature, the valve closes the flow of the heating medium.

DDC controller can be equipped with the communication ports RS232, RS485, and Ethernet due to the remote access. The remote access is one of the most required options because the controller data can be acquired remotely over the internet, which provides better comfort.

They also include inputs and outputs, both analogue and digital.

- Analogue inputs – e.g. signal from temperature sensor
- Analogue outputs – e.g. signal from controller to valve actuator
- Digital inputs – e.g. signal from fan motor indicating the ON/OFF state
- Digital outputs – e.g. ON/OFF signal from controller to fan motor

Example of DDC controller

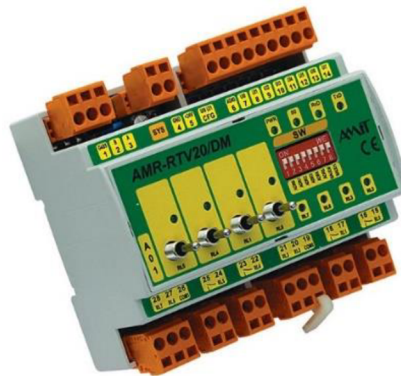

Figure 9. AMR-RTV20 by AMiT (taken from amit.cz)

There are many other companies that focus their products on the programmable controllers, for example, Teco, Siemens, Delta, Saia-Burgess, Sauter, etc.

3.2 Programmable Logic Controller (PLC)

PLC is a digital electronic system designed for use in industry automation, using internal memory to store user-created algorithms for the purpose of machine or processes control. From this definition, it is clear that the control process can be modified just by a change in an algorithm (1). The difference between DDC and PLC controllers is mainly in their field of usage. It can be stated that the DDC controllers are used in building automation (HVAC control, etc.). PLCs are freely programmable, but both can communicate with other devices via a communication bus system. The use of DDC and PLC controllers has several advantages in comparison with relays including 80% reduction of wiring, less power consumption, greater reliability and easy error detection.

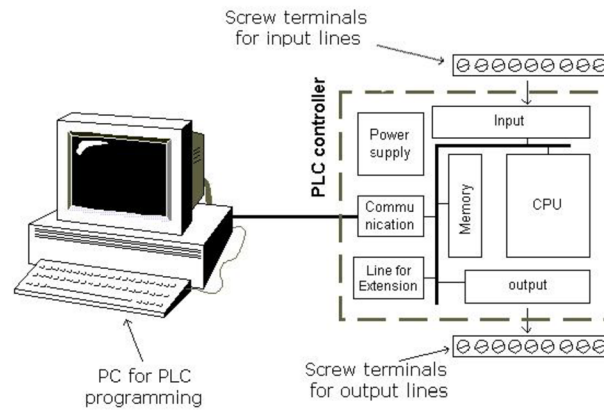

Figure 10. The PLC controller diagram (taken from program-plc.blogspot.cz)

Example of PLC controller

PLC controller AMAP99S designed by Czech company AMiT can control up to 24 digital inputs, 21 digital outputs, 15 analogue inputs and 6 analogue outputs.

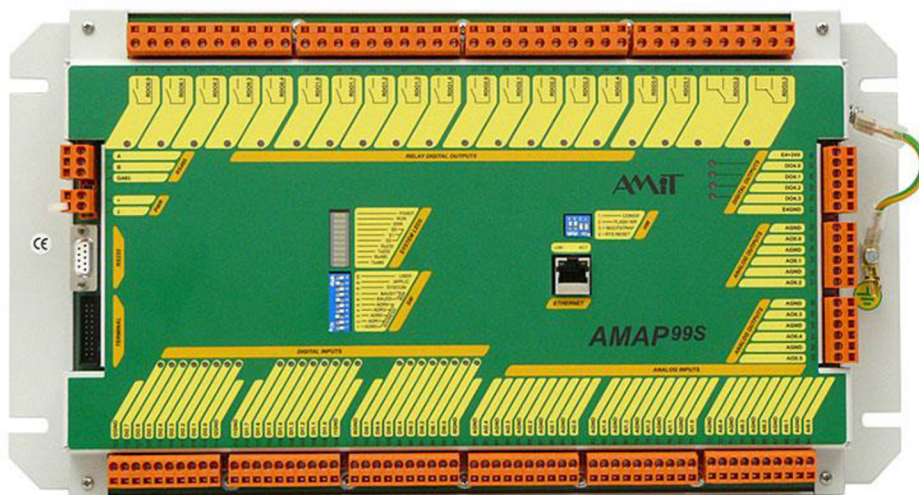

Figure 11. AMAP99S by AMiT (taken from amit.cz)

3.3 Communication protocols

The communication protocol is a set of communication rules used by communicating entities. They are based on the OSI model. OSI model consists of seven layers:

Layer 1. Physical – defines the connection, electrical, and wiring specifications. Operates in units of bits

Layer 2. Logical link – provides hardware addressing and error detection/correction. Operates in units of frames

Layer 3. Network – addresses and routes datagrams. Performs fragmentation and reassembly (IP). Operates in units of packets

Layer 4. Transport – manages connections and provides reliable packet delivery. Operates in units of messages

Layer 5. Session – establishes sessions between services. Synchronizes and performs translations for naming services

Layer 6. Presentation – performs data format conversion. Provides compression, encoding, and encryption of data

Layer 7. Application – provides standard services to applications and end-user interfaces

With regard to the requirements of the entire modern control system, the controllers have to communicate with I/O modules, control stations, and subsystems. The used type of communication protocol depends on the purpose of the signal, and the standard of a company. The communication between modules and controllers is based on the distributed system.

3.3.1 BACnet

Building automation and control network. This communication protocol was created specifically for the use in automation. The usual applications of BACnet are HVAC control, fire detection and report, lighting control, safety and guard systems, and control interface. BACnet is a national standard in more than 30 countries, and an ISO global standard (ISO 16484-5). It is not the classic complete communication bus, but it can be stated that BACnet controls the upper layers of the communication model and on the lower layer it uses the existing communication systems such as TCP/IP or RS485. What makes BACnet special is that it was built specifically to the needs of building automation and control equipment. It includes the operations such as asking for the value of temperature or sending a pump status alarm. The BACnet protocol defines a number of services that are used to communicate

between building devices. The protocol services include who-is, I-am, who-has, I-have, which are used for device and object discovery. Services such as read-property and write-property are used for data sharing. The BACnet protocol defines a number of Objects that are acted upon by the services. The objects include analogue input, analogue output, analogue value, binary input, binary output, binary value, multi-state input, multi-state output, calendar, event-enrolment, file, notification-class, group, loop, program, schedule, command and device (5).

3.3.2 Modbus

Modbus is an application layer communication protocol enabling the client-server communication type on different networks and busses. The main purpose is to exchange data typical for the field of automation. The communication is based on the transactions including request and response – Master and Slave.

The initial request consists of code that is specifying a function and function data. The response consists of function code corresponding to the request and specific data of response. In the case of error, the so-called exception response consists of the function code corresponding to the request plus the error code 0x80 and code specifying the exception. The size of such a package is limited to 256 bytes and this made it easy to transfer over any IP link.

3.3.3 LonWorks

The LonWorks technology is characterized by the universal communication over any possible wiring including RS485, 230V or cable TV. It is commonly used in building automation, or it can be used in remote energy meter reading, etc. The advantages of the LonWorks are in the open platform and its versatility. Their range of use is very wide, from supermarkets to factories, cars to trains or airplanes, and appliances to skyscrapers. In simple terms, it can be stated that LonWorks is able to transmit data from anywhere to anywhere over anything. LonWorks' expansion is said to be comparable with the internet expansion. The protocol used to communicate is called LonTalk. Unlike the TCP/IP, this protocol defines all seven layers of Open Systems Interconnection model. Lower six layers are included in neuron chip and designer is only programming the application layer.

4 Operator level

4.1 SCADA

SCADA is the Supervisory Control and Data Acquisition system that enables remote monitoring and control of individual plants up to multiple sites on large distances. SCADA system can control and monitor industrial processes (production, manufacturing, power generation...), facility processes (HVAC, security access, energy consumption...), or infrastructure processes (waste management, water distribution, power distribution, wind farms...)

In basic SCADA architectures, data from sensors or manual inputs are sent to PLCs (programmable logic controllers) or RTUs (remote terminal units), which then send that information to computers with SCADA software. SCADA software analyzes and displays the data in order to help operators and other workers to reduce waste and improve efficiency in the manufacturing process. Effective SCADA systems can result in significant savings of time and money. Numerous case studies have been published highlighting the benefits and savings of using a modern SCADA software solution (7).

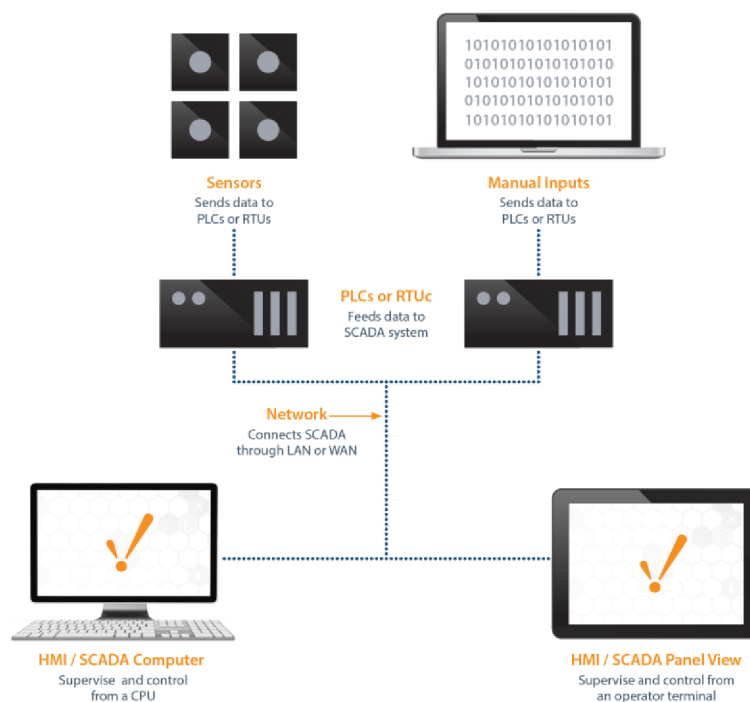

Figure 12. Basic diagram of SCADA (taken from inductiveautomation.com)

Modern SCADA systems allow real-time data from the plant floor to be accessed from anywhere in the world. This access to real-time information allows governments, businesses, and individuals to make data-driven decisions about how to improve their processes. Without SCADA software, it would be extremely difficult, if not impossible, to gather sufficient data for consistently well-informed decisions. The introduction of modern IT standards and practices such as SQL and web-based applications into SCADA software has greatly improved the efficiency, security, productivity, and reliability of SCADA systems (9).

4.2 HMI

The Human-Machine Interface is the user interface in a manufacturing or process control system. It provides a graphics or text-based visualization of an industrial control and monitoring system. Previously called an "MMI" (man-machine interface), an HMI typically resides in an office-based Windows computer that communicates with a specialized computer in the plant such as a programmable logic controller (PLC) or distributed control system (DCS) (10). Devices such as APT 130 by AMiT or TD 200 by Siemens are the examples of HMI. It usually visualises actual trends of particular values and shows selected data from databases (alarms, events, historical trends...).

SCADA, HMI, and other similar expressions are well known and distinguished abroad, but their use in domestic vocabulary is rather confusing.

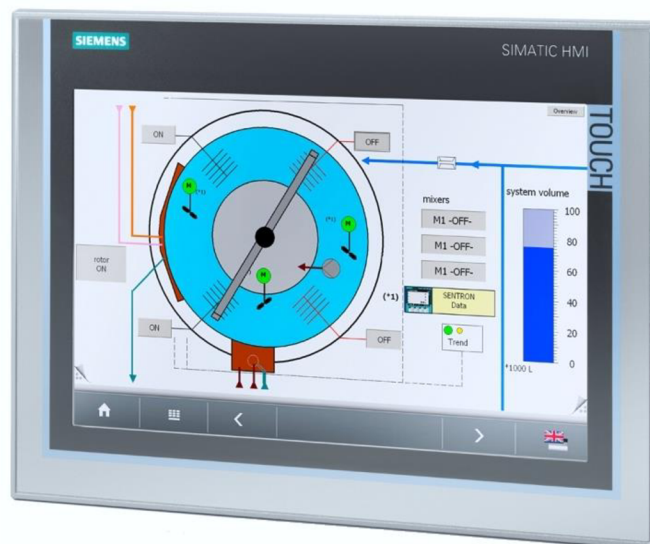

Figure 13. Simatic TP1900 by Siemens (taken from hypertech.hk)

5 Project documentation

The project documentation of buildings is governed by the Decree no. 62/2013 amending Decree no. 499/2006. It consists of many different parts including BMS.

Project documentation is the major thing when executing a project. It consists of various documents defining the entire project life. A big part of the project documentation includes the project drawings and the technical information about the technology used. The project documentation often did not remain equal at the end as it was at the beginning. The designer is facing many technological problems after the beginning of the construction. These problems have to be marked, and of course fixed, and all versions of the documentation should be archived.

Below in figure 14 is the timeline of the project documentation which should help understand its sequences.

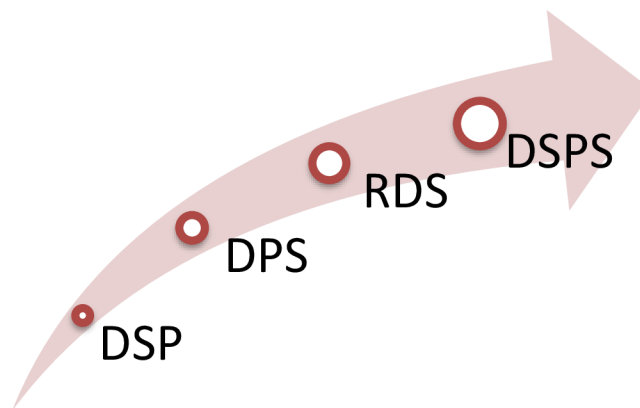

Figure 14. Timeline of the project documentation

Every country has its own unique title of the project documentation, Czech one is given by the Decree no. 62/2013 amending Decree no. 499/2006. The change of the titles would be confusing, so there are only the Czech abbreviations mentioned. Here are the English equivalents for the used terminology:

- Dokumentace pro stavební povolení – Documentation for building permit
- Realizační dokumentace stavby – Execution drawing documentation
- Dokumentace skutečného provedení stavby – As-built documentation

For example, in the building permit documentation, only the general options of the realisation are outlined. They are not discussed in details. In the tender documentations these options are discussed in more details, but they are still very general. The execution

documentation deals with the particular details of the project and should include the functional diagram, technical report, bill of material, etc.

5.1 Textual part

Project documentation can be divided into two parts relating to their content and textual part is one of them. It consists of the following documents:

The first important document is the Technical report, which includes identification data about the construction, investor, and builder, then the technology used in the project, the requirements, and their solution, safety regulations, general conditions, and the standards of the specific field.

Next document is a table of I/O, which defines every input and output linked to the DDC or PLC. It shows the number of pins, from where to where the connection goes, the type of signal, etc. Table of inputs and outputs is based on the technological/functional diagram.

Other documents, which are included in textual part, are bills of material, services, and peripherals. They are commonly combined into one document called a bill of quantities. The content of this bill depends on the actual requirements of the investor or nature of the project.

Last part of the documentation should be the list of appliances. It shows all the necessary data such as power outputs and inputs, input current, maximum voltages, etc.

5.2 Drawing part

Drawing part consists of different kind of drawings. Each drawing represents the specific task. The software for the drawings is usually CAD based.

The first drawing represents the functional diagram showing all peripherals and appliances, and their connections to the system. This drawing is essential when executing the table of inputs and outputs. BMS design is usually the last thing that is executed because the design of the project depends on the documentation of the other technicians. Figure 15 shows some common parts such as dampers actuators, fans, VFDs, temperature sensors, etc. For example, it can be seen that the damper actuator on the output is digitally controlled, the heating unit is connected to the digital input and digital output, etc.

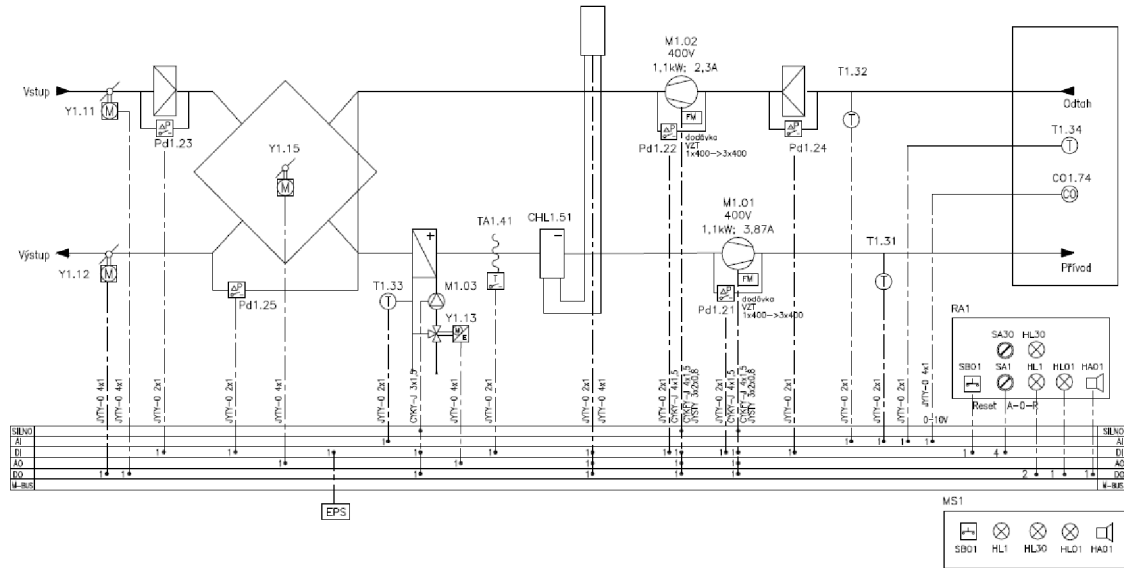

Figure 15. Example of functional diagram

Next drawing represents the diagram of power lines because there are many active elements that have to be powered. The difference between single-line and three-line diagrams is that the phases L1, L2, and L3 in TL are drawn each as a single line. This drawing is usually executed by the executor of the BMS parts of the project. The example of a single-line diagram is shown in figure 16.

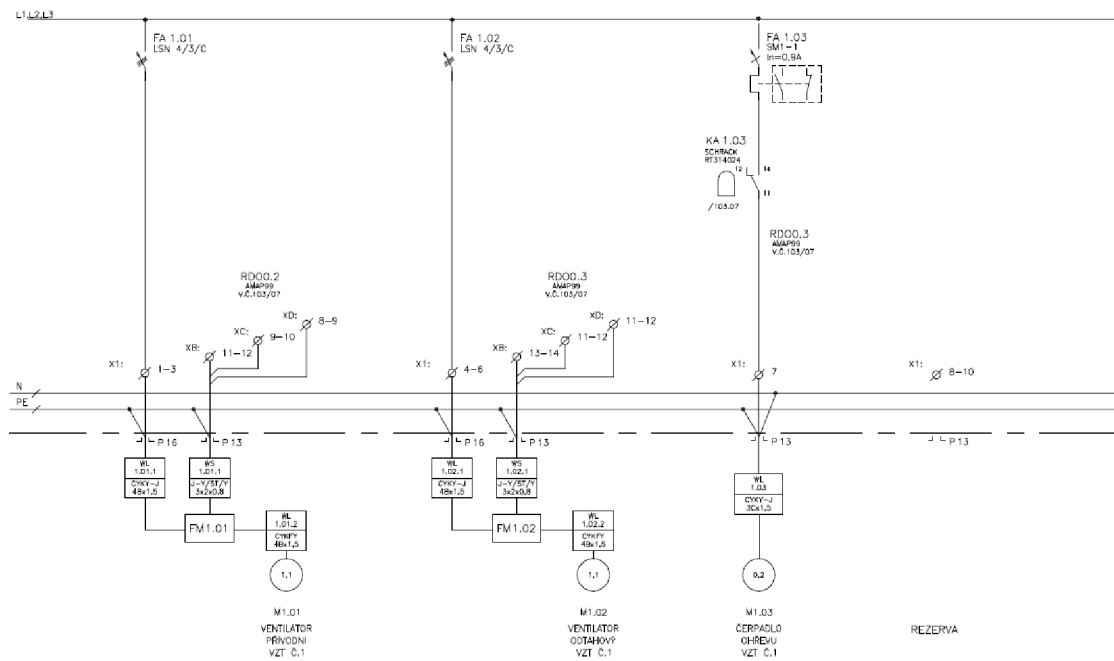

Figure 16. The example of a single-line diagram

Another drawing represents the schematic diagram, which enables the designer to show how the sensors and other elements of the system are connected with the DDC or PLC controller. This schema shows relays, indicators, sensors, terminals, etc. in connection with controllers and modules.

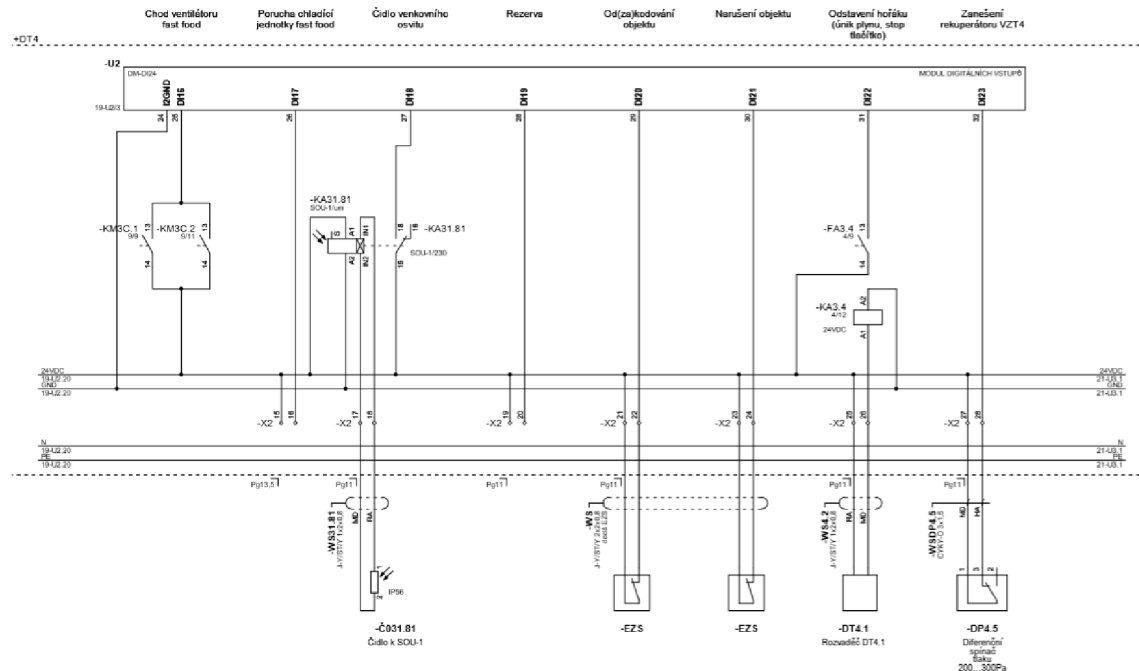

Figure 17. The example of schematic diagram

The last drawing is the floor plan. Its purpose is to show specific location of all the peripherals, switchboards, and wiring. The total length of cables can be calculated from the drawing. It helps people orientate within devices.

6 Practical case

6.1 Project

The project is based on the personal experience, and it is situated into the reconstruction of the shopping mall. It is a complete reconstruction so that the standards of the investor can be fulfilled. There are two appendices which are also part of the project. One is a functional diagram and the other is floor plan. Due to the nature of the project, bill of quantities and table of I/O are not included.

The documentation for building permit is not necessary for our project. As long as our company has won the contract to reconstruct all the shopping malls of our investor, even the tender documentation is not necessary anymore. Actual project deals with the execution drawing documentation. It differs from the previous ones in specific details.

Execution documentation is ordered by the investor. Its content is given by government Decree and a general documentation includes the following:

- A. Covering message
- B. Technical report
- C. Technical drawings/plans
- D. Drawings of technological equipment
- E. Certificates

6.1.1 Technical report

Content:

1. Project ID
2. Project structure
3. Project base documents
4. Electrical details
5. BMS switchboards
6. Description of the existing solution
7. Description of the new solution
8. Description of the control system
9. Cable distribution
10. Safety and organizational instructions
11. Used standards

1. Project ID

Construction:	XYZ Mall, Paradise city
Location:	Paradise city, 5 th Avenue
Investor:	ZYZZ Paradise republic
Stage:	RPD
BMS management:	Kunicky & Co.

2. Project structure

Project deals with the reconstruction of the existing building management system according to the new standards of the company. An existing control system, located in the BMS switchboard RA1, is the AMiT compact control system AMAP99, without the Ethernet connection. The APT130 display is located on the BMS switchboard panel. AMAP99 will be replaced by the newer version AMAP99S, due to the aging of the control system (insufficient memory capacity for new software), the need for expansion modules, expansion of the communications and addition of the Ethernet communication for the remote access. Due to the addition of new technological equipment to the system, it is necessary to extend the control system by universal modules DM-UI8AO8, which will be placed in a new BMS switchboard RA1.1. The existing module ART267A will be removed.

BMS will be complemented with control solutions of HVAC for the sales area based on the CO2 sensor located within the area; fan motors by variable frequency drives; air curtains at the entrance and the background facility according to the difference between outside and inside temperature or door contact; sales area lighting and outdoor billboards.

3. Project base documents

- Building layout of the sales area and background facilities – 2016
- Requirements of the investor and architectural office
- Consultation with the designers of other professions (electrician, Ventilation technician, heating technician)

4. Electrical details

Distribution system

RA1 3PEN, 50Hz, 230/400V, TN-C-S

Control system 1NPE, 50Hz, 230V

24VAC, 50Hz, 24VDC

Protection against indirect contact according to the ČSN 33 2000-4-41 will be done by automatic disconnection of power supply.

Additional protection by: Main bonding

 Additional bonding

 Residual-current device

Protection against direct contact:

By location, barrier, enclosure, cover, isolation, additional protection

Bonding:

Additional bonding will be used to bond live parts of machine rooms by the CY 6 mm cable.

Characteristics of surroundings in terms of external influences is considered according to ČSN 33 2000-3. In the case of any other external influences, it is necessary to consider the suitability of the designed equipment and eventually consider replacing them with equipment with higher IP code.

5. BMS switchboards

RA1

Existing switchboard RA1 is located within the boiler room (room 1.80). Both power equipment and BMS equipment for HVAC and heating are powered from this switchboard. The switchboard's dimensions are 2000x800x300 mm. The removed ART267A module will be replaced by a new one – DM-UI8DO8.

RA1.1

New switchboard RA1.1 is located next to the RA1. The switchboard's dimensions are 2000x600x300 mm. There will be located variable frequency drives with two expansion modules DM-UI8AO8 and DM-UI8DO8

MS1

Existing signal switchboard is located in the head office (room 1.49) in a height of about 1,4m. There are placed operating and fault indicators of main parts of the system, horn, and its reset button.

MS6.01-02

Existing signal switchboards are located on the wall in front of and inside the mechanical room. There is placed horn, button for air exhaust in case of alarm, and indicator of gas leak. Switchboards are partially damaged, so they will be replaced by new ones.

6. Description of the existing solution

Central heating

Two boilers in cascade control serve as a source of a hot domestic water. There are two temperature sensors attached to heating and return water piping, they ensure the thermal gradient to be 90/70°C. Water used for heating is connected to the common heating circuit distributor, where it is divided into three heating circuits: Multiflair heating devices, Ventilation + air curtains, and one for the heating system. Multiflair and Ventilation heating circuits are not regulated, but the heating system circuit regulation depends on the outside temperature. The control of heating circuits is provided on the basis of the control system, which is common for Ventilation, using three-way control valves and pumps. Safety button is placed near the boiler room entry doors.

Controlled properties:

- Cascade control of two two-stage boilers
- Control of heating circuits pumps
- Control of three-way control valves
- Control of the gas shutoff valve
- Reading of the temperature sensors
- Signalling of operation and fault conditions of boiler room
- Safety shutdown
- Automatic – manual switch. Manual means 100% power of boilers

Ventilation

Air condition of sales area – device no.1

BMS deals with the power and control of the air handling unit which is composed of the following components:

Input – damper, filter, mixing section, heating section, single speed fan

Output – two single speed fans

Controlled properties:

- Control of input and mixing dampers according to the operation of system
- Control of Multiflair units
- Anti-freeze protection of heating unit
- Control of the room temperature – $t = 18/20^{\circ}\text{C}$
- Control of the input air temperature and heating water
- Switching different operation modes
- Signalling of operation and fault conditions
- Automatic – manual switch

Additional heating of sales area – device no.1A

Heat losses are covered by the four pieces of Multiflairs. They are based on the warm air heating system, and their power can be regulated.

Ventilation of background facilities – device no.3

There is an air handling unit under the ceiling in the room no. 1.46. It is composed of the following components:

Input – damper, filter, heat recovery unit with by-pass, heating section, two-speed fan

Output – damper, filter, heat recovery unit with by-pass, two-speed fan

Controlled properties:

- Anti-freeze protection of heating unit
- Control of the input air temperature
- Remote control of by-pass damper
- Control of the input air temperature and heating water
- Signalling of the operation and fault conditions of the system
- Switching different operation modes (daily, weekly, monthly)

Ventilation of the cooling room – device no.6

There are two axial fans VAP620, which are mounted on the ceiling. The air is exhausted into outdoor space. The operation of fans is automatic and dependent on the room temperature which cannot exceed 35°C.

Safety ventilation of the cooling room – device no.6A

In the case of emergency, the safety operation of two fans must exhaust at least one-half of the air at the floor level, due to the leakage of coolant. The operation of fans is automatic and dependent on a signal from gas leak sensor.

NOTE: It is recommended to check functional diagrams together with the technical report for the better orientation within devices. Diagrams are attached in appendix A.

7. Description of the new solution

Central heating

There are two new boilers VISSMANN VITODENS 200 according to the project of a new boiler room. Peripherals should remain identical, but they will be replaced by new ones. All the inputs and outputs will match the existing project. Only the control of boilers is now done by the cascade controller VITOTRONIC 300-K. BMS will provide following:

- Disassembly of existing cabling and supporting material from the RA1 switchboard to peripherals of a boiler room
- Disassembly of existing temperature sensors and safety sensors, including STOP button gas leak, flood and pressure loss sensors
- Assembly of new temperature sensors and safety sensors
- Three-way valve ESBE DN25, $k_v=6,3$ for heating circuit
- Assembly of new cables to peripherals and new technology of boiler room
- Connection of cables into RA1 and RA1.1 switchboard, testing and commissioning

Ventilation

Air condition of sales area – device no.1

The existing air handling unit remains. BMS will add a temperature sensor and CO2 sensor inside the sales area, together with the variable frequency drives of input and output fans that will be fitted in the new RA1.1 switchboard. There must be used cabling with shielding CYKFY-J 4x2,5 between VFDs and fans. The speed of fans will be controlled by VFDs according to the room temperature and CO2 concentration within sales area.

Additional cooling of sales area – device no.10

Additional cooling will be provided by a pair of splits consisting of the outdoor condensing unit, located within the manipulation area, and two indoor units within the sales area. BMS deals with the blocking of splits in relation to the heating. It should be blocked by potential free contact placed in the main indoor unit. The blocking module will be provided by BMS.

Air curtains – devices no.2.1 and 2.2

Both air curtains will be powered from the BMS switchboard together with the operation control. Air curtains must be operated in an automatic mode. The operation of the main entrance air curtain depends on the difference between indoor and outdoor temperature, and operation hours of the mall. Temperature around air curtains is heated to constant temperature. This is ensured by the thermostatic valve. The operation of the background facility air curtain depends also on the difference between indoor and outdoor temperatures, and on the door opening (contact from the Security Alarm System). There will be added the temperature sensors in the area of main entrance and manipulation area entrance.

Lighting control

The opening hours are seven to twenty. Control of the lighting will be provided by the six potential-free break contacts.

Security alarm system will provide two contacts – one for arm/disarm of the object and one for break-in.

Lighting control modes are following:

- Entrance lighting – according to the timetable, ON 15 minutes before the opening, and OFF 30 minutes after closing time
- Arcade lighting – according to the timetable, ON 15 minutes before the opening, and OFF 30 minutes after closing time
- Billboards and outdoor lighting - – according to the timetable, ON 15 minutes before the opening, and OFF 30 minutes after closing time, it is also dependent on the signal from twilight sensor
- Background facilities lighting – according to the timetable, ON 15 minutes before the opening, and OFF 30 minutes after closing time
- 2/3 of the lighting – according to the timetable, ON 15 minutes before the opening, and OFF 30 minutes after closing time
- 1/3 of the lighting – ON when disarming or in the case of intrusion, OFF when arming.

Cables will be provided by BMS, mounting them between the switchboards will provide related profession.

Consumption metering

BMS deals with the measurement of electrical energy, water flow, and lighting energy. Cables between switchboards and connection of measuring devices will provide BMS.

Water flow measurement should communicate over M-BUS.

Electrical energy measurement should communicate by M-BUS.

Measuring devices will be provided by individual professions. The RS232/M-BUS converter will be a part of the RA1.1 switchboard.

8. Description of the control system

Main control system – DDC1

AMAP99S was specially designed for controlling small to middle-sized autonomous systems, especially for thermal units control and company energetics. By simply connecting the system to the network, it is possible to create relatively extensive information systems in terms of both territorial aspects and the total number of technological inputs and outputs.

The AMAP99S system is mounted to the switchboard base plate; its all-metal design and a special design of electronic circuits provide high interference resistance.

AMAP99S supports direct connection with the APT130 terminal. Using the AM-xx, and DM-xx modules, the system can be extended by an analogue and digital I/O, and additional communication lines like RS232, RS485, CAN, M-Bus etc. (11).

Table 1. AMAP99S technical data (taken from amit.cz)

Number of digital inputs	24
Number of digital outputs	19+4
Number of analogue inputs	15
Number of analogue outputs	up to 6
Communication lines	1× RS232, 1× Ethernet, 1× optional
Cover protection rate	IP20, metal cover
Power supply	24V DC ±20%
Operating temperature	0 to 65 °C (AMAP99S)
Dimensions (w × h × d)	400 × 230 × 70 mm

LCD Terminal

The APT130 industrial terminal has been developed for the AMAP99S control system. It uses the special parallel line implemented with these systems. (11)

Table 2. APT130 technical data (taken from amit.cz)

Type	character-based
Display	LCD back-lit display, 4×20 characters, cursor, 5×8 points character matrix;
Character height	4 mm
Keyboard	membrane type with 27 keys
Signalling	no
Communication interface	parallel
Cover protection rate	IP55 - front panel, IP20 – rear panel
Parametrisation	DetStudio
Power supply	5V DC ±10% from the control system
Operating temperature	0 to 50 °C
Dimensions (w × h × d)	146 × 166 × 51 mm

Remote I/O modules – DDC2, DDC3, DDC4

Remote modules are used to expand the number of inputs and outputs of the control system and to connect remote signals, thus making considerable cost savings on cabling. The values are transferred to the control system via a secure communication protocol and therefore cannot be distorted. (11)

Table 3. DM-xx technical data (taken from amit.cz)

Communication line	RS485
Galvanic separation	Yes
Communication rates	9600 to 57600 Bd
Number of modules on RS485	Max. 63
Power supply	24V DC \pm 20%
Power consumption	According to type (100 to 150mA)
Signal connection	WAGO cage clamp connectors
Cover protection rate	IP20
Operating temperature	0 to 50 °C
Mounting	35 mm DIN rail
Dimensions (w × h × d)	(105 × 90 × 74) mm

9. Cable distribution

Actuators and sensors are connected by JYTY cables (or CYKY) via terminal blocks XA1, XA2, XB2, XC1, XC2, XD1, XD2, XE1, and XE2, which are located in the RA1 switchboard. Motors are connected by CYKY cables via terminal X1. Variable frequency drives are connected by CYKFY cables in the RA1.1 switchboard. Cables will be fitted into MARS cable trays along electro-installation cables and through safety wiring ducts and pipes. Cables for temperature and CO2 sensors will be brought to the sales area and the area near air curtains. Temperature and CO2 sensors will be placed on the supporting column at the height of 1,8 m and 0,8 m.

10. Safety and organizational instructions

It is necessary to abide the ČSN standards when operating with electrical installations. Any operations on the electrical installation must be executed only on executed devices by skilled electricians according to the Decree no. 50/1978 Sb verification.

Assembly works of electrical equipment will be finished by appropriate tests, initial inspection of all electrical installation, and initial inspection report with the final handover of the building to the investor.

Electrical installation must be subjected to initial inspection. The operator of the building is obliged to ensure the periodic inspections of electrical installations after the initial inspection within the deadlines specified in IEC 331500 and initial inspection report.

11. Used standards

ČSN 33 2000-4-41 ed.2 – Protection for safety - Protection against electric shock

ČSN 33 2000-5-51 ed.3 – Selection and erection of electrical equipment – Common rules

ČSN 33 2000-5-54 ed.3 – Selection and erection of electrical equipment – Earthing arrangements and protective conductors

ČSN 33 2130 ed.3 – Low-voltage electrical installations – Internal electric distribution lines

ČSN 07 0703 – Gas boiler houses

Conclusion

The aim of this bachelor thesis was to describe the basic knowledge of the building management system, the necessary project documentation, and use the theoretical knowledge to conduct a project documentation of an actual BMS design.

This paper gives the insight into the necessary part of modern buildings. This work is divided into two parts, one is theoretical and the second one is practical. The first part includes six chapters. The first chapter describes what the Heating, ventilation, and air-conditioning (HVAC) control means and how it is provided. There are also discussed heat sources, individual room control, etc. Next three chapters are discussing different types of Building management system levels. They include the peripheral, automation and operator level. Peripheral level consists of descriptions of sensors (temperature, pressure, air quality, gas leak, etc.) and actuators (variable frequency drives and damper actuators). Automation level consists of the DDCs and PLCs, their differences and usage. Operator level deals with the systems that allow people interact with the system on the user level. It consists of SCADA system and Human-machine interface. The fifth chapter deals with the general project documentation, describing major parts of the project documentation and shows examples.

Last chapter discuss the execution of a particular project, it includes the technical report and the project introduction. Another necessary documentation is included in the appendices. The functional diagram is included in appendix A, the floor plan is included in appendix B.

The savings due to BMS can be 60%. The investment costs of the BMS are quite high for the individual people, so the major consumers are big companies. Benefits of the BMS outweigh the disadvantages. One of the biggest benefits of using BMS is the higher energy efficiency, then it can reduce operation and maintenance costs, and lower utility costs. When the utility costs are lower it increases the net income of the building and enhances its value. It also provides excellent occupancy comfort and fewer complaints. With computer controlled operations in the building it makes building operation easier and trouble free. BMS helps in reduction in energy consumption and also reduces the production of carbon dioxide emissions (12).

The project mentioned in the practical part was approved and its further development is not the subject of this bachelor thesis. Every name, logo, etc. was removed from the original document. The start of the project is postponed until autumn 2016.

List of figures

Figure 1. Manual and Automatic thermostatic head (taken from fonetip.cz).....	10
Figure 2. Example of air handling unit (taken from lufberg.com)	11
Figure 3. Diagram of the thermocouple sensor (taken from analog.com).....	15
Figure 4. Simple twilight sensor (taken from theben.de)	16
Figure 5. How the PIR sensor works (taken from elprocus.com)	17
Figure 6. Example of air quality measuring (taken from quantifiedbob.com)	18
Figure 7. Example of the mounting (taken from directindustry.com).....	19
Figure 8. Simple diagram of DDC control (taken from tzb-info.cz).....	21
Figure 9. AMR-RTV20 by AMiT (taken from amit.cz).....	22
Figure 10. The PLC controller diagram (taken from program-plc.blogspot.cz)	23
Figure 11. AMAP99S by AMiT (taken from amit.cz)	23
Figure 12. Basic diagram of SCADA (taken from inductiveautomation.com)	26
Figure 13. Simatic TP1900 by Siemens (taken from hypertech.hk)	27
Figure 14. Timeline of the project documentation	28
Figure 15. Example of functional diagram	30
Figure 16. The example of a single-line diagram	30
Figure 17. The example of schematic diagram.....	31

List of tables

Table 1. AMAP99S technical data (taken from amit.cz)	40
Table 2. APT130 technical data (taken from amit.cz).....	41
Table 3. DM-xx technical data (taken from amit.cz)	42

List of appendices

Appendix A – Functional diagram

Appendix B – Floor plan

Literature

- [1.] BENEŠ, Pavel. 2005. *Automatizace a automatizační technika*. Vyd. 2. Brno: CP Books, viii, 280 s. ISBN 80-251-0795-7.
- [2.] Regulace od Jardy. 2006. In: *Co bychom měli vědět o klimatizaci* [online]. [cit. 2015-12-15]. Dostupné z: http://valter.byl.cz/sites/default/files/co_bychom.pdf
- [3.] *Automatizace - Snímače teploty* [online]. [cit. 2015-12-15]. Dostupné z: <http://automatizace-issnp.wz.cz/Soubory/Snimace%20teploty.pdf>. Studijní materiál. ISŠ, Kumburská 846, Nová Paka.
- [4.] *Snímače teploty, teplotní sondy - Sensit s.r.o* [online]. 2013. [cit. 2015-12-15]. Dostupné z: www.sensit.cz
- [5.] BACnet - rt-labs. 2015. *Rt-labs - the EtherCAT embedded company* [online]. [cit. 2015-12-15]. Dostupné z: <http://www.rt-labs.com/products/software-platform/bacnet/>
- [6.] DUFF, Matthew a Joseph TOWEY. 2010. Two Ways to Measure Temperature Using Thermocouples Feature Simplicity, Accuracy, and Flexibility. In: *Analog Dialogue 44-10* [online]. [cit. 2015-12-16]. Dostupné z: <http://www.analog.com/library/analogDialogue/archives/44-10/thermocouple.pdf>
- [7.] What is a Variable Frequency Drive? 2014. In: *VFDs.com* [online]. [cit. 2016-05-10]. Dostupné z: <http://www.vfds.com/blog/what-is-a-vfd>
- [8.] Legally controlled measuring instruments. 2016. *Czech metrology institute* [online]. Brno [cit. 2016-05-10]. Dostupné z: <https://www.cmi.cz/node/588?language=en>
- [9.] What is SCADA? Supervisory Control and Data Acquisition. 2016. *Ignition: One Platform, Unlimited Possibilities* [online]. [cit. 2016-04-24]. Dostupné z: <https://inductiveautomation.com/what-is-scada>
- [10.] HMI Definition from PC Magazine Encyclopedia. 2016. *PCMag.com* [online]. [cit. 2016-04-24]. Dostupné z: <http://www.pcmag.com/encyclopedia/term/44300/hmi>
- [11.] *Control Systems and Industrial Electronics - AMiT* [online]. 2016. [cit. 2016-05-10]. Dostupné z: <http://www.amit.cz/>
- [12.] RAMADAN, Mohamed. 2014. What is the Benefits of BMS? In: *Linkedin.com* [online]. [cit. 2016-05-21]. Dostupné z: <https://www.linkedin.com/pulse/20140613163312-46288852-what-is-the-benefits-of-bms>