

VYSOKÉ UČENÍ TECHNICKÉ V BRNĚ  
BRNO UNIVERSITY OF TECHNOLOGY

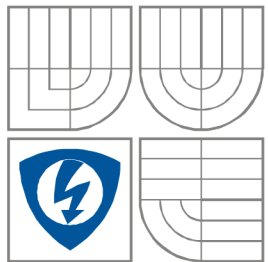

FAKULTA ELEKTROTECHNIKY A KOMUNIKAČNÍCH  
TECHNOLOGIÍ  
ÚSTAV JAZYKŮ

FACULTY OF ELECTRICAL ENGINEERING AND COMMUNICATION  
DEPARTMENT OF FOREIGN LANGUAGES

# CALCULATION OF HEAT LOSSES OF A BUILDING AND A DESIGN OF A CONVENIENT HEATING SYSTEM

VÝPOČET TEPELNÝCH ZTRÁT BUDOVY A NÁVRH VHODNÉHO SYSTÉMU VYTÁPĚNÍ

BACHELOR'S THESIS  
BAKALÁŘSKÁ PRÁCE

AUTHOR  
AUTOR PRÁCE

Stanislav Popelka

SUPERVISOR  
VEDOUČÍ PRÁCE

Ing. Jan Mikulka, Ph.D.  
PhDr. Ludmila Neuwirthová, Ph.D.

BRNO, 2015



VYSOKÉ UČENÍ  
TECHNICKÉ V BRNĚ

Fakulta elektrotechniky  
a komunikačních technologií

Ústav jazyků

# Bakalářská práce

bakalářský studijní obor  
**Angličtina v elektrotechnice a informatice**

**Student:** Stanislav Popelka

**ID:** 154658

**Ročník:** 3

**Akademický rok:** 2014/2015

## NÁZEV TÉMATU:

**Výpočet tepelných ztrát budovy a návrh vhodného systému vytápění**

## POKYNY PRO VYPRACOVÁNÍ:

Cílem práce je teoretický rozbor návrhu vhodného vytápění objektu. Bude provedena literární rešerše v oblasti vytápění budov spolu s rozбором souvisejících norem.

## DOPORUČENÁ LITERATURA:

- [1] Lorente, S. Heat Losses through Building Walls with Closed, Open and Deformable Cavities. International Journal of Energy Research, 2002.  
[2] současně platné normy

**Termín zadání:** 9.2.2015

**Termín odevzdání:** 22.5.2015

**Vedoucí práce:** Ing. Jan Mikulka, Ph.D.

**Konzultanti bakalářské práce:** PhDr. Ludmila Neuwirthová, Ph.D.

**doc. PhDr. Milena Krhutová, Ph.D.**

*Předseda oborové rady*

## UPOZORNĚNÍ:

Autor bakalářské práce nesmí při vytváření bakalářské práce porušit autorská práva třetích osob, zejména nesmí zasahovat nedovoleným způsobem do cizích autorských práv osobnostních a musí si být plně vědom následků porušení ustanovení § 11 a následujících autorského zákona č. 121/2000 Sb., včetně možných trestněprávních důsledků vyplývajících z ustanovení části druhé, hlavy VI. díl 4 Trestního zákoníku č.40/2009 Sb.

# ABSTRACT

Heat losses of a building are a determining factor for the overall energy consumption spent on heating the building. Since construction and insulation materials are being constantly innovated, the heat losses remain a highly topical issue. The introductory chapters include properties of heat which are crucial in this work and the way of heat propagation. The construction and insulation materials and their heat features are also discussed in these sections. In the following chapter, the calculations of heat losses by natural ventilation and natural heat transfer are made. In the final chapters, the work primarily focuses on choosing an appropriate heating system. It briefly introduces the reader to a heat pump and evaluates its advantages and disadvantages. The aims of this bachelor thesis is to clarify the issues of calculating heat losses, to acquaint readers with factors crucial in the calculations and to choose suitable heat source. The calculations of heat losses are based on the Czech Standard – ČSN 06 0210:1994 „Výpočet tepelných ztrát budov při ústředním vytápění“.

# KEYWORDS

Calculation of heat losses, ČSN 06 0210, heat furnace, heat loss, heat pump, heat source.

# ABSTRAKT

Tepelné ztráty objektu jsou určující faktor pro celkovou spotřebu energie na vytápění budov a jelikož se materiály na stavbu a izolaci budovy stále inovují, jsou tepelné ztráty neustále aktuálním tématem. Úvod práce zahrnuje vlastnosti tepla, které jsou v této práci klíčové a způsoby jeho šíření. Práce se dále zabývá materiály na stavbu a izolaci objektu a zejména vlastnostmi těchto materiálů při kontaktu s teplem. Další kapitolou práce je výpočet tepelných ztrát větráním a přirozeným prostupem tepla. Závěr práce se věnuje především volbě vhodného vytápění. Stručně seznámí čtenáře s tepelným čerpadlem a zhodnotí jeho výhody a nevýhody. Cílem této práce je objasnit problematiku výpočtů tepelných ztrát a seznámit se s faktory, které jsou při výpočtech rozhodující. Dalším cílem práce je volba tepelného zdroje. Výpočet tepelných ztrát je proveden na základě – ČSN 06 0210:1994 „Výpočet tepelných ztrát budov při ústředním vytápění“.

## KLÍČOVÁ SLOVA

ČSN 06 0210, otopný zdroj, tepelná ztráta, tepelné čerpadlo, topný kotel, výpočet tepelných ztrát.

Popelka, Stanislav. *Calculation of heat losses of a building and a design of a convenient heating system*. Brno: Vysoké učení technické v Brně, Fakulta elektrotechniky a komunikačních technologií, Ústav jazyků, 2015. 45 s., 14 s. příloh. Bakalářská práce. Vedoucí práce: Ing. Jan Mikulka, Ph.D.

# PROHLÁŠENÍ

Prohlašuji, že svou bakalářskou práci na téma *Calculation of heat losses of a building and a design of a convenient heating system* jsem vypracoval samostatně pod vedením vedoucího bakalářské práce a s použitím odborné literatury a dalších informačních zdrojů, které jsou všechny citovány v práci a uvedeny v seznamu literatury na konci práce.

Jako autor uvedené bakalářské práce dále prohlašuji, že v souvislosti s vytvořením této bakalářské práce jsem neporušil autorská práva třetích osob, zejména jsem nezasáhl nedovoleným způsobem do cizích autorských práv osobnostních a/nebo majetkových a jsem si plně vědom následků porušení ustanovení § 11 a následujících zákona č. 121/2000 Sb., o právu autorském, o právech souvisejících s právem autorským a o změně některých zákonů (autorský zákon), ve znění pozdějších předpisů, včetně možných trestněprávních důsledků vyplývajících z ustanovení části druhé, hlavy VI. díl 4 Trestního zákoníku č. 40/2009 Sb.

V Brně dne .....

.....

(podpis autora)

## ACKNOWLEDGEMENT

I wish to express my sincere thanks to Ing. Jan Mikulka, Ph.D., for providing me with valuable guidance. I am also extremely grateful to PhDr. Ludmila Neuwirthová, Ph.D., for her counsel.

## **Contents**

<b>LIST OF SYMBOLS</b>	<b>9</b>
<b>PREFACE</b>	<b>11</b>
<b>1 TYPES OF HEAT DISTRIBUTION</b>	<b>12</b>
<b>2 BACKGROUND INFORMATION FOR CALCULATING HEAT LOSSES BY ČSN 06 0210</b>	<b>14</b>
<b>3 HEAT LOSS</b>	<b>16</b>
3.1 BASIC FORMULAS .....	16
3.2 HEAT LOSS ANALOGY .....	17
3.3 THERMAL BRIDGE AND THERMAL BINDINGS .....	18
3.4 HEAT LOSS BY NATURAL HEAT TRANSFER .....	20
3.5 HEAT LOSS BY VENTILATION .....	20
3.6 HEAT SURCHARGES .....	21
<b>4 PRACTICAL PART</b>	<b>23</b>
4.1 EXAMPLE OF CALCULATIONS .....	23
4.2 HEAT PUMP .....	32
4.3 ENERGY SOURCES .....	33
4.4 HEAT FURNACE .....	34
4.5 WHY TO CHOOSE HEAT PUMP .....	35
4.6 CHOICE OF SUITABLE HEAT SOURCE .....	37
4.7 TECHNICAL REPORT .....	39
<b>CONCLUSION</b>	<b>41</b>
<b>LIST OF FIGURES</b>	<b>42</b>
<b>LIST OF TABLES</b>	<b>43</b>
<b>REFERENCES</b>	<b>44</b>
<b>LIST OF ATTACHMENTS</b>	<b>45</b>



# LIST OF USED SYMBOLS

Designation	Name of quantities	Units
$A$	Cooled part of a building structure	[ m <sup>2</sup> ]
$C$	Specific heat capacity	[ J · kg <sup>-1</sup> · K <sup>-1</sup> ]
$C_v$	Volumetric heat capacity of air at 0 °C	[ J · m <sup>-3</sup> · K <sup>-1</sup> ]
$\delta$	Wall thickness	[ m ]
$h$	Height	[ m ]
$k_c$	Additional thermal charges	[ m ]
$l$	Length	[ m ]
$\lambda$	Coefficient of thermal conductivity	[ W · m <sup>-1</sup> · K <sup>-1</sup> ]
$n$	Air exchange rate number	[ h <sup>-1</sup> ]
$p_1$	Surcharge to equalize effect of cold structures	[ - ]
$p_2$	Surcharge to accelerate heating up	[ - ]
$p_3$	Surcharge based on cardinal direction	[ - ]
$Q$	Heat	[ Joule ]
$Q_c$	Total heat loss	[ W ]
$Q_{cp}$	Total heat loss including surcharges	[ W ]
$Q_p$	Heat loss by natural transfer	[ W ]
$Q_v$	Heat loss by ventilation	[ W ]
$R_i$	Thermal resistance of materials between $R_{se}$ and $R_{si}$	[ K · W <sup>-1</sup> ]
$R_{se}$	Thermal resistance of heat transfer on outside	[ K · W <sup>-1</sup> ]
$R_{si}$	Thermal resistance of heat transfer on inside	[ K · W <sup>-1</sup> ]
$R_t$	Thermal resistance	[ K · W <sup>-1</sup> ]

$t$	Temperature	[ °C ]
$t_{is}$	Internal mean temperature	[ °C ]
$t_z$	Calculation value of soil heat	[ °C ]
$t_1$	Internal temperature value	[ °C ]
$t_2$	External temperature value	[ °C ]
$\Delta t$	Temperature difference	[ °C ]
$U$	Heat transfer coefficient	[ W · m <sup>-2</sup> · K <sup>-1</sup> ]
$V_m$	Internal volume of space	[ m <sup>3</sup> ]
$V_v$	Volumetric flow of ventilation air	[ m <sup>3</sup> · s <sup>-1</sup> ]
$w$	Width	[ m ]

# PREFACE

Heat losses are a crucial element determining energy consumption of a building. Only the building whose construction included good quality materials, having thermal properties being in accordance with ČSN 73 0540 [2], is able to ensure that it will be energy-efficient, capable of providing pleasant environment regarding inner heat temperature and, not least, it will be minimizing heat losses. Meeting the above-mentioned standard is in compliance with general requirements for the construction. When the Czech Republic had joined the European Union in 2004, a series of amendments regarding the Czech standards occurred. It was necessary to unify the standards. The Czech standard describing the calculation of heat losses – ČSN 06 0210 [1] has been replaced by the ČSN EN 12831 [4]. However, the majority of coefficients which are established by the standard are of average values – they are created as a general basis and they have not been adjusted to the area of the Czech Republic. In thermal insulation of buildings and other objects, it is not possible to avoid various physical phenomena which are essential for understanding how heat escapes, whether it is thermal conductivity of materials, heat transfer through a single-wall (made of one material) or heat transfer through a composite wall (made of more than one material). Therefore it is necessary to clarify some physical phenomena and their properties. Libor Wilda [5] describes heat as a physical quantity which defines a change of a body state. Heat exchange occurs between two or more bodies, when the body with a higher temperature transfers its energy to the body with a lower temperature. The temperature is a feature of a thermal state of matter. It is a scalar quantity (i.e. it is fully determined by a single numerical value with regard to a selected unit). Another important quantity is thermal conductivity which is a physical property of a material that indicates its ability to conduct heat. An amount of heat required to heat 1 kilogram of substance by 1 degree of Celsius/Kelvin is called specific heat capacity. The heat transfer coefficient determines a rate of heat transfer from one medium to another. Thermal resistance expresses an ability of a material to insulate, i.e. to prevent heat transfer. Heat flux defines an amount of heat transferred in a certain period of time.

# 1 TYPES OF HEAT DISTRIBUTION

The most important factor that affects the size of heat loss is a building itself, more precisely, its envelope construction parts – walls, windows, doors, roof, floor etc. These parts separate the heated interior of the building from the cold exterior. Outside weather conditions like temperature, wind, sunshine and others cannot be changed. However, materials used for the structure can significantly affect the internal temperature. To reduce the heat loss it is necessary to understand how the heat escapes. It is generally known that the body with the higher temperature gives its heat energy to the body with the lower temperature. The quantity of transferred heat energy depends on the temperature difference between those two bodies and on their heat capacity. The speed of the process will depend on the type of transmission.

There are three basic ways how the heat is transferred in the building.

## **Thermal conduction**

Heat energy is actually a disorganized, chaotic motion of particles (atoms and molecules). When two bodies are in contact with each other, after a certain time the particles of the body with the higher temperature transmit their energy to the particles of the body with the lower temperature and this process continues until the heat energy of both bodies is even. Heat conduction with metals is an easy process; it is worse with non-metallic substances and liquids; and it is very poor in gases.

The degree of material heat conductivity is expressed by the coefficient of thermal conductivity. The coefficient of thermal conductivity is the quantity of heat that passes through a cube with dimensions of 1 square meter with the temperature difference of 1 °C. The lower the difference in temperature is, the worse the material conducts heat, i.e. having a higher insulating ability. Porous materials have the lowest coefficients, e.g. bricks, concrete, wood, etc. Their insulating ability depends on their moisture level. Water conducts heat well, so the wetter a material is, the better it conducts heat.

## **Convection**

With liquids and gases there is another way to spread the heat, which is the movement of substance. Metaphorically speaking, it can be said that convection is a „heat transfer with the body itself“. This transfer runs very easily with liquids but not so well with gases – due to their low density, the gases can accept only a small amount of heat. Natural convection occurs because warm liquids or gases are lighter and move up spontaneously. Forced convection is induced by an external force (e.g. pump, fan or wind).

Convection is characterized by a quantity called the heat transfer coefficient. The value of the heat transfer coefficient is equal to the quantity of heat which passes through the wall of dimensions of 1 square meter within 1 second; the higher the coefficient is, the more heat is transferred. The coefficient of heat transfer depends on both the type of substance that transfers the heat to the walls and the speed of substance. When calculating heat losses, heat transfer from the air to the wall (natural convection) is the most frequent form of convection.

## **Radiance**

This method of heat transfer shows high degree of occurring only in gases and in vacuum. Since the physical description of radiation heat transfer is complicated, in the construction practice it is usually combined with heat transfer by convection. The value of heat transfer coefficient thus includes also radiation heat transfer. The definition of radiation states; that each body whose temperature is higher than 0 Kelvin degree, emits electromagnetic radiation in all directions of the wavelengths. This radiation propagates at the speed of light [5].

## **2 BACKGROUND INFORMATION FOR CALCULATING HEAT LOSSES BY ČSN 06 0210**

**Heat loss** is the amount of a heat which is displaced, per time unit, from heated interior into exterior by either heat transfer through construction material or ventilation.

When calculating heat losses, the following background is needed:

- the location of the building, the altitude (height above sea level), the orientation of the object according to cardinal points (cardinal direction), the landscape in which the building is located,
- floor plans of each level and dimensions of rooms (including installation position of windows, doors and their dimensions),
- thermal properties of construction materials,
- information about the purpose of individual rooms or individual requirements for an internal temperature.

### **Outdoor temperature value for calculations**

The object is a small family house which is located near Brno at district Blansko. According to the Czech standards ČSN 06 0210 [1] and ČSN 38 3350 [6], the calculation value for the average outdoor temperature is  $-15\text{ }^{\circ}\text{C}$ .

### **Technical documentation**

Originally, sketches of the building were available. From the sketches, floor plans were created. The orientation of the object according to the cardinal points has been chosen by the investors. Technical documentation of the object was created in a program AutoCAD.

### **Internal room temperature for calculations**

The internal room temperature for calculations of each individual room is fixed by the Czech standard. The following table contains values of the above mentioned temperature. The table was compiled from the values specified in ČSN 06 0210 [1].

Tab. 1: Internal room temperature for calculations

Type of room	Internal temperature for calculations [°C]
Living rooms, bedrooms, dining room, kitchens, etc.	20
Bathrooms	24
Heated side rooms (halls, lobbies etc.)	15

## 3 HEAT LOSS

### 3.1 BASIC FORMULAS

The calculations of heat losses are based on the Czech Standard: ČSN 06 0210:1994 „Výpočet tepelných ztrát budov při ústředním vytápění“. [1]

The amount of heat, per time unit, which passes through a wall out of the room can be expressed by the following formula:

$$Q = U \cdot A \cdot \Delta t. \quad (1)$$

The amount of escaping heat depends on the temperature difference  $\Delta t$ , size of the wall surface  $A$  and mainly on the heat transfer coefficient  $U$ , which is related to the properties of the wall. The following formula is used for its calculation:

$$U = \frac{1}{(R_{si} + R_i + R_{se})}, \quad (2)$$

where  $R_{si}$  is the thermal resistance of heat transfer on the inside,  $R_{se}$  is the thermal resistance of heat transfer on the outside and  $R_i$  is the thermal resistance of materials between  $R_{se}$  and  $R_{si}$ . If the wall consists of several layers with different values of thermal conductivity and different thicknesses, then:

$$U = \frac{1}{(R_{si} + \sum R_i + R_{se})}. \quad (3)$$

For the thermal resistance of the wall, i.e. its individual layers, the following formula is used:

$$R_t = \frac{\delta}{\lambda}, \quad (4)$$

where  $\lambda$  represents the coefficient of thermal conductivity and  $\delta$  represents the wall thickness.

It is obvious that the thicker the building structure is, the higher the value of the thermal resistance is and the lower the value of the thermal conductivity of material is. Fortunately, there is no need to make many different calculations as manufacturers of



construction materials often provide the thermal resistance (or the heat transfer coefficient) of their specific products.

The following tab. 1 shows the above-mentioned values for typical construction elements.

Tab. 2: Values of thermal resistance and heat transfer coefficient

Construction type	Heat transfer coefficient $U$ [W/m <sup>2</sup> ·K]	Thermal resistance $R_t$ [m <sup>2</sup> ·K/W]
Brick wall - 450 mm	1.450	0.520
Wall of brick blocks POROTHERM - 450 mm	0.405	2.300
Wall of YTONG blocks - 400 mm	0.354	2.660
Roof construction made of ORSIL panels - 160 mm	0.300	3.200

The heat transfer coefficient, or more precisely the thermal resistance, is prescribed by ČSN 73 0540 [2]. Meeting this standard is in compliance with the general requirements for the construction.

### 3.2 HEAT LOSS ANALOGY

To explain heat losses more clearly, the heat transfer through a building structure can be seen as an analogy to the flow of electrical current through the resistance. Electric voltage which "pushes" current through the resistance corresponds to the temperature difference. The electric current corresponds to the heat flow and the electrical resistance corresponds to the thermal resistance. When a wall consists of several layers, it is actually the resistance in series; therefore the resulting resistance is the sum of the resistances of the individual layers. It is also known that with the connection of resistors in series, the total voltage (temperature difference) is in the proportion to their size; the higher the resistance is, the larger part of the voltage (temperature difference) is displayed there.

The figure below can be used as an illustration for understanding the difference in temperature progress in the wall with insulation and without insulation.

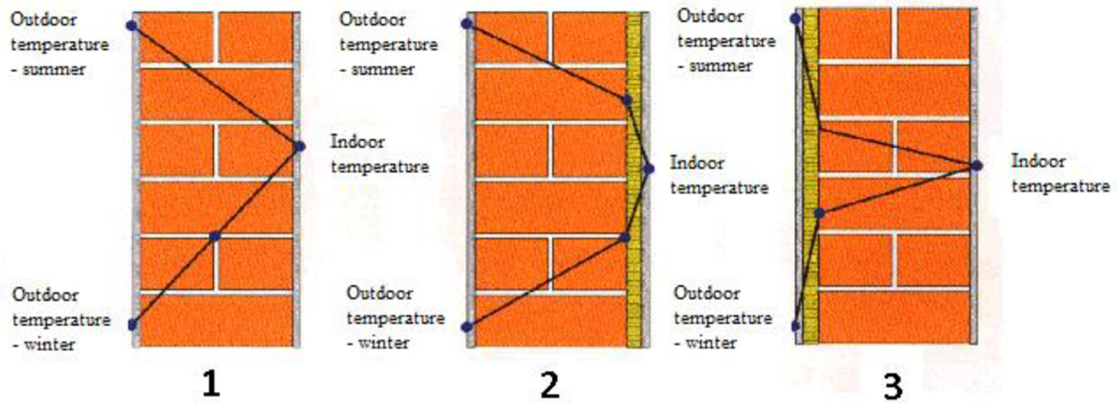

Fig. 1: The temperature progress in single-solid (non-insulated) wall, walls with the added layers of insulation [7]

### 3.3 THERMAL BRIDGE AND THERMAL BINDINGS

A thermal bridge is an area of a structure which is weakened in terms of heat insulation. In such places, the heat escapes much faster. However, calculations of heat losses according to the Czech Standard ČSN 06 0210:1994 [1] do not involve thermal bridges. This is a major problem as the influence of the thermal bridge on the heat loss by natural heat transfer is constantly increasing due to constant progress in thermal properties of construction elements.

Thermal bindings, which occur at the contact of adjacent structures, are unlike the thermal bridge given by the geometry of the building. For example, the outside corner of the room has a larger surface than the corner inside. The cooled area is larger than the heated area – i.e. the heat loss will probably be also larger. The contact of a window with the wall in which it is fitted can be another example of thermal bindings. Traditionally, windows are placed on the center of the wall thickness. In such a case, only the wall thickness of the window frame to the inner face of the wall withstands the outdoor temperature. This negative effect can be eliminated by fitting windows on the outside face of the wall.

An important parameter is the surface temperature of the structure; if it is too low, while staying close to the wall, we feel cold and there is an additional risk of condensation on the wall. The following diagrams in Fig. 2 and 3 show the heat loss of the individual parts of block of flats and houses. However, these are just approximate values.

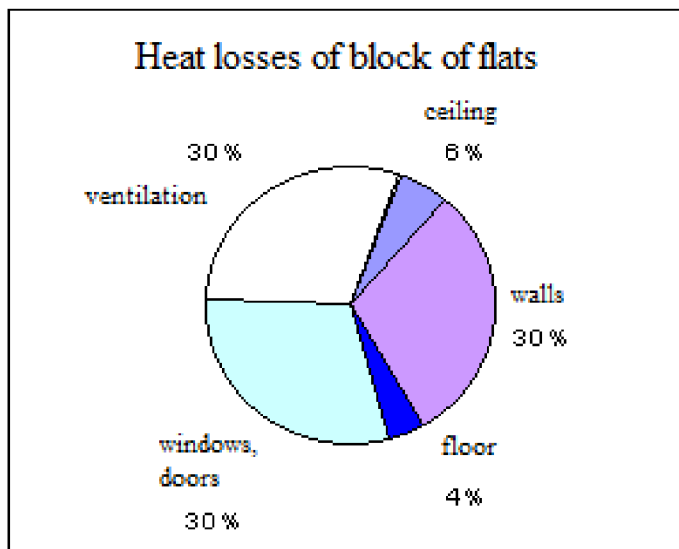

Fig. 2: Heat losses of block of flats [8]

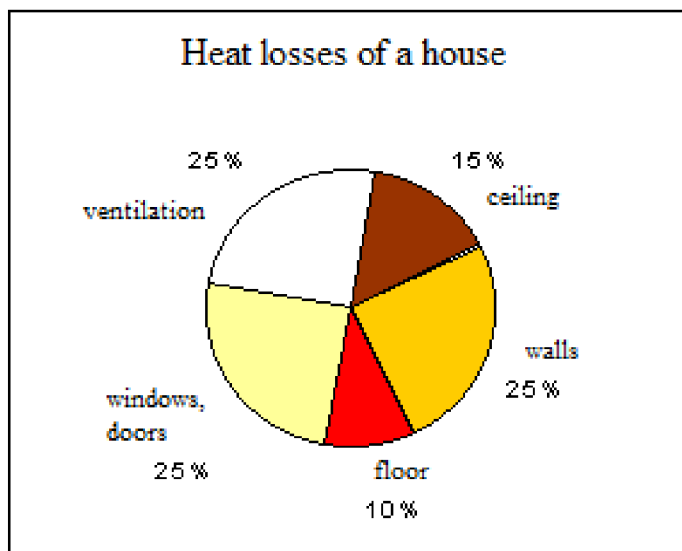

Fig. 3: Heat losses of a house [8]

### 3.4 HEAT LOSS BY NATURAL HEAT TRANSFER

Basic heat loss of a single material is given by the formula (1). Total heat loss by natural heat transfer is given by the sum of all constructions which are separating the inside of the building from the outside – walls, doors, windows, roof etc.

### 3.5 HEAT LOSS BY VENTILATION

In terms of ventilation, objects can be divided into buildings without a ventilation system and buildings with a ventilation system (a forced air change). The air exchange with buildings, which do not have a ventilation system, is usually ensured by air clefts in windows, exterior doors and by opening windows, i.e. natural ventilation. Such buildings may only be fitted with an underpressure ventilation system (fan to outlet air). Indoor air is exchanged with outdoor air and the need to warm up the exchanged air is supplied by a heating system. Houses with forced air inlets and outlets are in the simplest cases equipped with the recuperation system (the preheating of inlet air by the heat of outlet air). Both natural ventilation and the forced ventilation system have the same following procedure.

On the basis of requirements for indoor temperature (depending on the type of a building), the air exchange rate number is determined. The number indicates how many times per hour an internal volume of air is to be exchanged for outdoor air. For residential buildings, the number is  $n=0.3-0.6/h$  (the number usually used for calculations is 0.5).

$$Q_v = C_v \cdot V_v \cdot (t_1 - t_2), \quad (5)$$

where  $V_v$  stands for volumetric flow of ventilation air and  $C_v$  is volumetric heat capacity of air at 0 °C.

$$C_v = 1300 \text{ J} \cdot \text{m}^{-3} \cdot \text{K}^{-1}, \text{ approximately at mean temperature } t_m = 0.5 \cdot (\Delta t_1 + \Delta t_2)$$

$$V_v = \frac{n}{3600} \cdot V_m. \quad (6)$$

$V_m$  is the internal space volume which is calculated by the following formula.

$$V_m = l \cdot w \cdot h. \quad (7)$$

The internal space volume is calculated from three dimensions of a room – length, height and width.

### 3.6 HEAT SURCHARGES

Basic heat loss by natural heat transfer  $Q_p$  for the whole room is calculated as the sum of losses through all individual construction elements.

Basic heat loss by natural heat transfer, plus surcharges, give **total heat loss by natural heat transfer** of the calculated room:

$$Q_{cp} = Q_p \cdot (1 + p_1 + p_2 + p_3), \quad (8)$$

where  $p_1$  is a surcharge to equalize an effect of cold structures which depends on the average heat transfer coefficient of the calculated room.

The average heat transfer coefficient is determined as follows:

$$k_c = \frac{Q_c}{\Sigma S \cdot (t_1 - t_2)}, \quad (9)$$

where  $\Sigma S$  is the total area of structures bounding the heated room.

The surcharge to equalize the effect of cold structures  $p_1$  is then determined as:

$$p_1 = 0.15 \cdot k_c. \quad (10)$$

Surcharge  $p_2$  is to accelerate heating up. It is calculated only in scenarios when the uninterrupted heating cannot be ensured at the coldest outdoor temperatures (hospitals, libraries, municipalities etc.)

- 0.10 heating time is more than 16 hours.
- 0.20 heating time is less than 16 hours.

The surcharge  $p_3$  depends on the position (cardinal direction) of the most cooled room structures (a wall). If more room structures are cooled, then it is primarily their common corner which is a determinative of the surcharge. Calculations for rooms with three or more cooled structures (walls) are made for the biggest surcharge value (the North).

Tab. 3: Heat surcharges as given by ČSN 06 0210

Cardinal direction	S	SW	W	NW	N	NE	E	SE
Surcharge $p_3$	-0.05	0	0	0.05	0.1	0.05	0.05	0

## 4 PRACTICAL PART

### 4.1 EXAMPLES OF CALCULATIONS

The following chapter involves practical demonstration of calculation of heat losses, according to the ČSN 06 0210. Consequently, on the basis of the calculated heat losses an appropriate heat source is chosen.

#### *Materials used for outer wall construction*

Lime-cement plaster	12 mm
Mineral wool ISOVER	30 mm
OSB (Oriented strand board)	13 mm
Polystyrene	20 mm
YTONG	300 mm
Glass wadding ISOVER	50 mm
Drywall	12 mm

#### *Materials used for the roof*

Wood batens	40 mm
System ISOTEC	100 mm
Wood interior facing	40 mm
Vapor barrier	0.25 mm

#### *Materials used for the foundations*

Bearing plate	40 mm
Damp-proof-course FOALBIT	4 mm
Glass wadding ISOVER	50 mm
Concrete mixture	50 mm
Ceramic tiles	7 mm

The calculation example of the thermal resistance for lime-cement plaster using the formula (4).

$$R_t = \frac{\delta}{\lambda} = \frac{0.012}{0.990} = 0.0121 \text{ K} \cdot \text{W}^{-1}. \quad (11)$$

The coefficient of thermal conductivity is given directly by a manufacturer.

In certain cases the value of thermal resistance is given directly by a manufacturer – there is no need to calculate it. Similarly, the values of thermal resistance for individual construction elements were calculated and written down into tables below.

Tab. 4: Values of thermal resistance for outer wall construction elements

Construction element	Value of thermal resistance	Units
Lime-cement plaster	0.0121	$\text{K} \cdot \text{W}^{-1}$
Mineral wool ISOVER	0.833	$\text{K} \cdot \text{W}^{-1}$
OSB (Oriented strand board)	0.1	$\text{K} \cdot \text{W}^{-1}$
Polystyrene	0.53	$\text{K} \cdot \text{W}^{-1}$
YTONG	2.20	$\text{K} \cdot \text{W}^{-1}$
Glass wadding ISOVER	1.3	$\text{K} \cdot \text{W}^{-1}$
Drywall	0.545	$\text{K} \cdot \text{W}^{-1}$

Tab. 5: Values of thermal resistance for roof construction elements

Construction element	Value of thermal resistance	Units
Wood batens	0.308	$\text{K} \cdot \text{W}^{-1}$
System Isotec	4.77	$\text{K} \cdot \text{W}^{-1}$
Wood interior facing	0.27	$\text{K} \cdot \text{W}^{-1}$
Vapor barrier	0.41	$\text{K} \cdot \text{W}^{-1}$



Tab. 6: Values of thermal resistance for construction elements of foundations

Construction element	Value of thermal resistance	Units
Bearing plate	0.154	$K \cdot W^{-1}$
Damp-proof course FOALBIT	0.02	$K \cdot W^{-1}$
Glass wadding ISOVER	1.2	$K \cdot W^{-1}$
Concrete mixture	0.04	$K \cdot W^{-1}$
Ceramic tiles	0.0693	$K \cdot W^{-1}$

The calculation example of the heat transfer coefficient of outer wall construction using the formula (3).

$$U = \frac{1}{(R_{si} + \sum R_i + R_{se})} = \frac{1}{(1.475 + 2.20 + 1.845)} = 0.181 \text{ W} \cdot \text{m}^{-2} \cdot \text{K}^{-1}. \quad (12)$$

Similarly, the values of the heat transfer coefficient of the roof and foundations were calculated and written down into the table below.

Tab. 7: Heat transfer coefficient of roof and foundations construction

Type of construction	Heat transfer coefficient	Units
Roof elements	0.174	$W \cdot m^{-2} \cdot K^{-1}$
Foundations elements	0.674	$W \cdot m^{-2} \cdot K^{-1}$

## The roof system

A roof structure forms a horizontal covering construction of a building. It is generally known that warm air rises up. Therefore requirements for thermal properties of roof construction elements, regarding the heat transfer coefficient, are more demanding than for peripheral walls. Roofs with inclination smaller than  $45^\circ$  have a required value for the heat transfer coefficient  $U = 0.24 \text{ W} \cdot \text{m}^{-2} \cdot \text{K}^{-1}$ .

### Thermally-insulating system Isotec



Fig. 4: Roof system Isotec [10]

The composition of a roof deck is completely solved by using the Isotec system, including battening for subsequent installation of roofing in a single building element. After the mounting of the Isotec system, the roof is perfectly insulated, waterproof and battened. The isotec panels are made of flame-retardant polyurethane foam with closed pore structure (sealed against moisture). The both sides of the panels are covered with aluminium foil which has a reflective effect.

#### Advantages of the Isotec system:

- high-quality thermal insulation without thermal bridges,
- constant high thermal resistance,
- functional ventilation – space under roof covering,
- complete composition of roofing in a single building element.

## The calculation examples – heat loss by natural transfer

### Room 1.06 – Living room

The calculation of a window no.1:

The dimension of a French window

$$A = 3.50 \cdot 2.10 = 7.35 \text{ m}^2 \quad (13)$$

Heat loss

$$Q = U \cdot A \cdot \Delta t = 1.1 \cdot 7.35 \cdot [20 - (-15)] = 283 \text{ W} \quad (14)$$

The calculation of a window no.2:

The dimension of a French window

$$A = 2.10 \cdot 2 = 4.2 \text{ m}^2 \quad (15)$$

Heat loss

$$Q = U \cdot A \cdot \Delta t = 1.1 \cdot 4.2 \cdot [20 - (-15)] = 161.7 \text{ W} \quad (16)$$

The calculation of wall construction:

Surface of the wall

$$A = 7.775 \cdot 2.5 = 19.44 \text{ m}^2 \quad (17)$$

Heat loss

$$Q = U \cdot A \cdot \Delta t = 0.181 \cdot 19.44 \cdot [20 - (-15)] = 123.2 \text{ W} \quad (18)$$

The sum of heat losses:

$$Q_c = 283 + 161.7 + 123.2 = 567.9 \text{ W} \quad (19)$$

Additional thermal charges:

$$k_c = \frac{Q_c}{\Sigma S \cdot (t_1 - t_2)} = \frac{567.9}{(29.98) \cdot [20 - (-15)]} = 0.541 \quad (20)$$

$$p_1 = 0.15 \cdot k_c = 0.15 \cdot 0.541 = 0.0812 \quad (21)$$

$$p_3 = 0.1 \quad (22)$$

The total heat loss by transfer (including additional thermal charges):

$$Q_{cp} = Q_p \cdot (1 + p_1 + p_2 + p_3) = 567.9 \cdot (1 + 0.1 + 0.0812) = 670.8 \text{ W} \quad (23)$$

## The calculation example – heat loss by ventilation

### Room 1.06 – Living room

The cubic capacity of the room:

$$V_m = w \cdot l \cdot h = 7.1 \cdot 2.8 \cdot 2.5 = 49.7 \text{ m}^3 \quad (24)$$

The air flow volume:

$$V_v = \frac{n}{3600} \cdot V_m = \frac{0,5}{3600} \cdot 49.7 = 0.0069 \text{ m}^3 \cdot \text{s}^{-1} \quad (25)$$

The ventilation heat loss:

$$Q_v = C_v \cdot V_v \cdot (\Delta t_1 - \Delta t_2) = 1300 \cdot 0.0069 \cdot (20 - (-15)) = 314.08 \text{ W} \quad (26)$$

## The calculation of heat loss through the roof of the building

### The calculation of roof windows

A roof window no.1:

The dimension of a window

$$A = 1.20 \cdot 0.9 = 1.08 \text{ m}^2 \quad (27)$$

Heat loss

$$Q = U \cdot A \cdot \Delta t = 0.86 \cdot 1.08 \cdot [24 - (-15)] = 36.22 \text{ W} \quad (28)$$

An identical process of calculation was used for two remaining roof windows and calculated data was consequently put into the table below.

Tab. 8: Calculated values of roof windows

Type of construction	Dimension of window	Heat loss
Roof window no.1	1.08 m <sup>2</sup>	36.22 W
Roof window no.2	1.08 m <sup>2</sup>	32.5 W
Roof window no.3	1.08 m <sup>2</sup>	32.5 W

### The calculation of roof dimensions

The surface of the roof - pitched roof (angle 37°)

The total roof surface (windows included)

$$A = 8 \cdot 7 = 56 \text{ m}^2 \quad (29)$$

The roof surface

$$A = 56 - (3 \cdot 1.08) = 52.76 \text{ m}^2 \quad (30)$$

Heat loss

$$Q = U \cdot A \cdot \Delta t = 0.174 \cdot 52.76 \cdot [20 - (-15)] = 321.31 \text{ W} \quad (31)$$

The total heat loss by transfer:

$$Q_c = 36.22 + 32.5 + 32.5 + 321.31 = 422.53 \text{ W} \quad (32)$$

Heat surcharges:

$$k_c = \frac{Q_c}{\Sigma S \cdot (t_1 - t_2)} = \frac{422.53}{(56) \cdot [20 - (-15)]} = 0.2156 \quad (33)$$

$$p_1 = 0.15 \cdot k_c = 0.15 \cdot 0.2156 = 0.0323 \quad (34)$$

The total heat loss by transfer (including additional thermal charges):

$$Q_{cp} = Q_p \cdot (1 + p_1 + p_2 + p_3) = 422.53 \cdot (1 + 0.0323) = 436.21 \text{ W} \quad (35)$$

## The calculation of heat loss through foundations

The total area of all rooms of the ground floor: 52.33 m<sup>2</sup>

Heat loss

$$Q = U \cdot A \cdot (t_{is} - t_z) = 0.674 \cdot 52.33 \cdot [18 - (-6)] = 846.49 \text{ W} \quad (36)$$

Note:

$t_{is}$  - (18 °C for residential buildings)

The value for calculating  $t_z$  was taken from the table below which was compiled from the values in the ČSN EN ISO 13370. [11]

Tab. 9: Values for calculation of ground heat

Location of adjacent ground	Temperature of adjacent layer $t_z$ [°C] with outdoor temperature calculation $t_{ev}$ [°C]			
	-12	-15	-18	-21
under the floor	+5	+5	+5	+5
under 1 m depth	-3	-3	-6	-6
1 to 2 m depth	0	0	-3	-3
2 to 3 m depth	+3	+3	0	0
over 3 m depth	+5	+5	+5	+5

## The enumeration of heat losses

The total heat loss of the house is the sum of all individual losses of cooled constructions.

Tab. 10: Total heat losses

Type of heat loss	Calculation according to ČSN 06 0210	Units
Heat loss by natural transfer – ground floor	1,074	W
Heat loss by natural transfer – first floor	470.95	W
Heat loss by ventilation – ground floor	815.21	W
Heat loss by ventilation – first floor	584.06	W
Heat loss through roof	436.21	W
Heat loss through foundations	846.49	W
Total heat loss	4,227	W

## 4.2 HEAT PUMP

The heat pump is a highly efficient device for obtaining energy from renewable natural resources – water, earth, air. It draws heat from one place to another by exerting external work. The most common type is a compressor heat pump. It works on a principle of the reverse Carnot cycle. The Carnot cycle, proposed by Nicolas Léonard Sadi Carnot, is a thermodynamic cycle.

*„The second law of thermodynamics states that it is impossible to extract heat from a hot reservoir and use it all to do work; some must be exhausted into a cold reservoir. Or, in other words, no process can be 100% efficient because energy is always lost somewhere. The Carnot Cycle sets the upper limit for what is possible, for what the maximally-efficient engine would look like. Stage 1 is an isothermal expansion, where the volume increases and the pressure decreases at a constant temperature. This is where heat enters the system from the hot reservoir (i.e., from your power source) to keep the temperature constant. The gas inside the engine is allowed to naturally expand and push a piston.*

*Stage 2 is an adiabatic expansion, where the hot reservoir is now taken away. The gas continues to expand, causing the pressure and temperature to decrease. Stages 1 and 2 are where the engine actually does useful work. Stage 3 is an isothermal compression, where the volume decreases and the pressure increases at a constant temperature. The temperature is kept constant by putting it in contact with a cold reservoir. Lastly, stage 4 is an adiabatic compression, where you remove the cold reservoir. The volume continues to decrease but without the cold reservoir, this leads to both the pressure and temperature increasing. The useful work that comes out of the Carnot Cycle is the difference between the work done by the engine in stages 1 and 2, and the work done (or the energy wasted) in stages 3 and 4.“ [12]*

The refrigerant in a gaseous state is compressed by the compressor and admitted into a condenser. Here, it releases its latent heat. The condensed refrigerant passes through an expansion nozzle into an evaporator where the latent heat (at a lower pressure and temperature) is received and evaporated. Then it once again proceeds to the compressor and the whole cycle repeats.



One of the main characteristics of the heat pump is the coefficient of performance (COP), which is basically the ratio of heating capacity and electrical power. It indicates how many times larger power is obtained (energy output) against exerted power (energy input). The higher the temperature of the natural heat source and the lower the temperature of the medium in the heating system are, the higher the COP is.

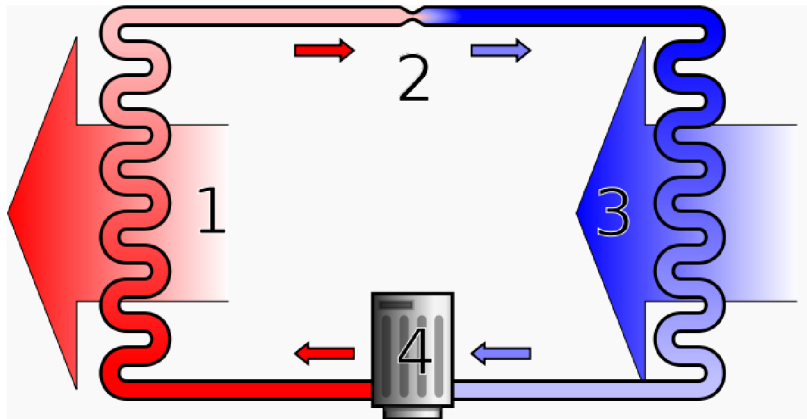

Fig. 5: A simple diagram of a heat pump's cycle. 1 - condenser, 2 - expansion valve, 3 - evaporator, 4 - compressor. [13]

### 4.3 ENERGY SOURCES

- **Earth** - Geothermal energy stored in rocks or accumulated solar energy in the upper layers of soil (used for pumps with the system earth/water).
- **Air** - Used for pumps with the system air/water or air/air.
- **Water** - Mostly subterranean water from a borehole, which transfers its heat to a medium in the heating system and then is returned to the ground via another borehole (used for system the water/water).

## 4.4 HEAT FURNACE

A heat furnace is probably the most widely used heat source. The heat furnace is a device in which heat is generated by combustion of solid, liquid or gaseous fuel which consequently warms heat-carrying substance. There are numerous types of heat furnaces. There are *heat furnaces for solid fuels* – wood, coal, biomass, pellets, wood chips and other waste from wood processing or fast growing trees grown specifically for this purpose. Then there are *heat furnaces for liquid gases* which are using various types of heating oils. *Gas heat furnaces* are usually running on natural gas or propane-butane, and the last branch are *electric heat furnaces*. Each of these have their advantages and disadvantages.

Tab. 11: Prices and power performance of heat furnaces

Type of heat furnace	Power [kW]	Price [CZK]
Electric	4 - 60	10,000 - 25,000
Gas (conventional)	8 - 30	20,000 - 50,000
Gas (condensing)	4 - 35	25,000 - 65,000
Bituminous coal + wood	10 - 42	20,000 - 40,000
Lignite Coal + wood	6 - 45	15,000 - 35,000
Pyrolytic	8 - 36	38,000 - 65,000
Gasification of wood	15 - 100	30,000 - 130,000

*Note: The prices and power performance mentioned are rough values taken from the internet – exceptions may be found.*

The choice of the type of the heating system and the heat source are primarily influenced by a fuel type, its local availability, storage options and price trends. Crucial criteria are calorific values, efficiency and operator comfort.

## 4.5 WHY TO CHOOSE HEAT PUMP

Considering availability of electricity and gas, not to mention other fuels such as wood or coal, a heat furnace seems to be a very good source of thermal energy. The heat furnace which would be needed to cover heat losses of an average family house should have power 7 – 12 kW. Its price ranges between tens of thousands of crowns. Let us consider the choice of an electric heat furnace. Taking into account increasing prices of electricity, it does not seem to be a wise choice. A gas heat furnace has been lately widely used as a heating system for family houses. Operating costs are determined by the price of fuel and prices of natural gas have not been on a drop for the past few years, the contrary seems to be true. A good substitute for natural gas could be liquefied gas – propane-butane or propane. However, it is necessary to acquire an outdoor fuel storage tank in this case. Several companies in the market offer the leasing of such fuel storage tanks and ensuring maintenance. The cost of the lease of the reservoir is about 1,000 Czech crowns per year. Nevertheless, the price development of liquefied gases depends solely on the price of petroleum which can be expected to be on a rise in future. Heat furnaces running on solid fuels are more time demanding – the attention has to be paid to them more often. In addition, they require either the closeness of a fuel source and thus its availability or an option of long-term storage directly at home. Frequent maintenance and a constant need of re-fueling are huge disadvantages.

The choice of a heat pump presents a lot of advantages. At first, there is no need to worry about energy prices because the heat pump draws heat directly from nature. Next, it reduces approximately 80 % of energy costs, which leads to the rapid return of investment. Even though the return depends on a type of the heat pump, the investment can be returned within 6 - 10 years. Other benefits are the low energy consumption and the use of natural energy leading to lesser burden on the environment. Another convenience is its easy operation – the heat pump can be controlled via a mobile phone or the internet. In the case of built-in smart house technology, an interconnection between those two can be easily managed to control central heating. Moreover, there is no need to be worried about the danger of explosion, fire or poisoning of CO<sub>2</sub>. On top of that, the heat pump produces negligible noise.

The biggest disadvantage is its high purchase price, depending mostly on the size of the object (and thus the power), and on a technology system. Anyone who purchases the heat pump is assigned with the beneficial two-rate electricity supply for the whole household by energy distribution companies. In the case of the single-rate electricity supply the price of electricity is charged equally for 24 hours. In the case of the two-rate supply it is differentiated into two price bands. Electricity is charged with a significantly lower price at the time of a low-price-band tariff in comparison with a high-price-band tariff when a charge for electricity is fixed. The period of the low-rate is determined under the conditions established by the distributor pricing decision of the Energy-Regulatory-Office. The low-rate is fixed for a maximum of 22 hours per day.

**Summing up the advantages:**

- easy operation,
- negligible noise level,
- energy prices independence,
- economical and ecological heating,
- convenient two-rate energy supply,
- rapid return of investment.

The required initial investment of approximately 160,000 - 300,000 Czech crowns is subsequently offset by low operating costs. A determining factor when choosing the suitable heat pump is not only the power which is needed for heating-up the building but also a decision what sort of a system is possible to use at the specific building.

The pumps with the system air/air provide heating by ventilation and for this reason such a system does not need to be connected with classical heating systems. In addition, this type can create entirely hygienic inside air and deprive inside air of any kind of allergens. However, there is the possibility of increased noise in the immediate vicinity of the outdoor heat pump. An outdoor location of the heat pump can also act as an aesthetically disturbing element. Operational demands on the compressor are higher than with systems drawing heat from earth or water, which results in a shorter lifespan. At low outdoor temperature, the COP is highly reduced and thus operating costs are

growing. None of the heat pumps with the system air/water being currently available in the market can cover the heating requirements throughout the year, which is a reason why this type is often combined with a boiler, floor heating system or other heat sources. Nowadays, the most effective type in the market is water/water. It would be the best choice in the case when a reservoir, river or another water source is nearby. If there is not such a source, it is necessary to drill a deep borehole or create a pond which is not a cheap solution. For this reason, the system water/water should be considered when a water source is directly or very close to the object.

The earth/water system utilizes heat of soil. Anti-freezing mixture circulates in a plastic tube which is several hundred meters long (earth collector). Since the frost-free depth has a constant temperature which is approximately 4 °C, the mixture passing through the collector gathers the heat of the soil and then proceeds to the heat exchanger of the heat pump (evaporator) where it is cooled off – the heat gain is removed and the cooled mixture heads back to the collector for re-heating. Thus the cycle repeats itself.

## **4.6 CHOICE OF SUITABLE HEAT SOURCE**

Since the subject building has no water source in its surroundings, the system water/water is not suitable. As mentioned above, the system air/air has shorter lifespan than all the other systems because of a higher operational demand on the compressor. Also at low outdoor temperature, the COP is highly decreased which results in the growing of operating costs and none of the heat pumps with the system air/water being currently available can cover the heating requirements throughout the year.

The structure has an extensive area that is a free zone, which is an ideal place for the earth collector. Thus the system earth/water is a convenient solution both from the financial and location points of view.



Fig. 6: Heat pump NIBE F1255 - power performance 4 – 16 kW [14]

Purchase price with all accessories: 289,000 CZK

**Investment return: 6 – 8 years**

*„Heat pump featuring earth/water system equipped with continuous power regulation. A revolutionary solution comprising a compressor driven by a frequency converter, built-in boiler and intelligent control system. The heat pump adjusts in any given time to the demands for heating the building. When more heat capacity or more hot water is needed, the performance will automatically enhance and when the need for heat capacity cuts back, the revolutions of compressor cuts back also. Given the fact that the heat pump operates under optimal operating conditions throughout the year, it is maximazing benefits and minimizing energy costs.“ [14]*

Although this heat pump has its limit performance far beyond investor's needs, it has a beneficial effect on the investor's future plans. The high performance will allow to expand the house without further changing the capacity of the installed heat source. Another advantage is that it requires a small installation place. In addition, the integrated 9 kW heater will automatically turn on to serve as a reserve supply in the case of the operation failure. On hot summer days it will allow cooling with fans.

## 4.7 TECHNICAL REPORT

The heat pump must be connected via the main switch. Electrical feed will be connected to the terminal block through a cable gland. Other electrical components are already set up in the factory, there is no need to deal with them. If the building is equipped with an RCD (Residual Current Device), the heat pump must be equipped with a separate RCD. If a circuit breaker is used, it has to have a motor characteristic „D“ (compressor operation). If too many energy appliances are connected to the same line the heat pump is on, it may cause the main circuit breaker to open. The heat pump is equipped with an integrated load monitor that controls power performance of the heater. When the phase current is so high that there is a risk that the main circuit breaker will open, the load monitor first suspends additional heat sources. If that is not sufficient, the compressor capacity will be limited to the half.

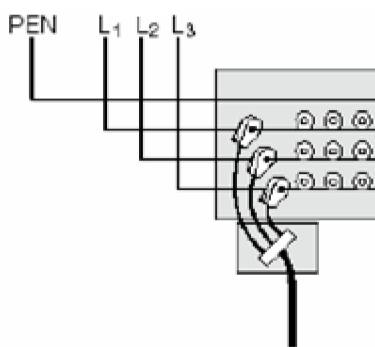

Fig. 7: Electrical feed of the heat pump [14]

## Technical parameters

Tab. 12: Technical parameters of NIBE F1255 [14]

Name of parameter	Value
Nominal power	4 - 16 kW
Volume of hot water tank	180 l
Required ceiling height	1800 mm (without legs: 30 - 50 mm)
Width	600 mm
Depth	620 mm
Net weight	245 kg
Voltage	400 V (3 - phase+N)
Amount of refrigerant (R407C)	2.2 kg
Reserve mode/ electric heat furnace	9 kW

Used RCD: Three-phase circuit breaker 16 A (characteristic D)

- Breaking capacity of circuit breaker 10 kA according to ČSN EN 60898-1 [15].
- Nominal voltage 230/400 V~.



Fig. 8: Three-phase circuit breaker 16 A [16]



## CONCLUSION

The aim of the thesis was to calculate heat losses according to the Czech standard ČSN 06 0210. The object was a small, new-built family house. As contemplated, the calculated heat losses are rather small – 4,227 W. Regarding individual rooms, the living room downstairs has the largest area and therefore the highest losses – 670 W. Values given by the material producers were used for calculations. Subsequently the calculations were verified whether they meet the Czech standards. A major problem with the used Czech Standard ČSN 06 0210 is that it does not include the influence of thermal bridges on heat losses by natural heat transfer. This influence is constantly increasing due to progress in thermal properties of construction materials.

It is also important to emphasize that the Czech Standard ČSN EN 12831, taken over from the European Standard EN 12831 which is supposed to replace the standard ČSN 06 0210, could have been used for calculations. However, majority of coefficients established by the standard ČSN EN 12831 are of average values, they are created as a general basis and have not been adjusted for the area of the Czech Republic. This explains why the calculations based on this standard cannot be considered to be accurate. In addition, the ČSN EN 12831 does not take into account heat losses of unheated rooms (halls, lobbies, etc).

The chosen heating system is not cheap; however, the investment should be returned within 6 - 8 years. The high performance of the heating system will allow the investors to expand the house in future, as they intend to do it, without changing the installed capacity. Furthermore, because of the heat pump, the whole household works in the beneficial two-rate electricity supply for a maximum of 22 hours a day.

## REFERENCES

- [1] ČSN 06 0210: Výpočet tepelných ztrát budov při ústředním vytápění, 1994.
- [2] ČSN 73 0540 - 2: Tepelná ochrana budov – Part 2: Požadavky, 2002.
- [3] ČSN 73 0540 - 4: Tepelná ochrana budov – Part 4: Výpočtové metody, 2005.
- [4] ČSN EN 12831: Tepelné soustavy v budovách – Výpočet tepelného výkonu, 2005.
- [5] Libor Wilda: Elektrické teplo – textbook for SPŠE, 91 p.
- [6] ČSN 38 3350: Zásobování teplem: Všeobecné zásady, 1991.
- [7] Portal <http://www.ekowatt.cz/>. [online]. [cit. 2015-02-20] Available at: <http://www.ekowatt.cz/uspory/ztraty.shtml>.
- [8] Portal <http://www.tzb-info.cz/>. [online].  
- Specialized information server regarding building construction and building equipment.
- [9] Portal <http://www.energetika.cz/>. [online].
- [10] Portal <http://www.studioconti.cz/>. [online]. [cit. 2015-02-20] Available at: <http://www.studioconti.cz/index.php?page=co-je-isotec>.
- [11] ČSN EN ISO 13370: Tepelné chování budov – Přenos tepla zeminou – Výpočtové metody, 1999.
- [12] Portal <http://study.com/>. [online]. [cit. 2015-02-21]. Available at: <http://study.com/academy/lesson/efficiency-the-carnot-cycle-equations-examples.html>.
- [13] Portal <http://en.wikipedia.org/>. [online]. [cit. 2015-03-07]. Available at: <http://en.wikipedia.org/wiki/File:Heatpump2.svg>.
- [14] Portal <http://nibe.cz/>. [online]. [cit. 2015-03-07]. Available at: <http://www.nibe.cz/cs/tepelna-cerpadla-zeme-voda/tepelne-cerpadlo-f1255>.
- [15] ČSN EN 60898-1: Elektrická příslušenství – Part 1: Jističe pro nadproudové jištění domovních a podobných instalací, 2003.
- [16] Portal <http://ielektra.cz/>. [online]. [cit. 2015-03-07]. Available at: <http://www.ielektra.cz/jistic-trifazovy-16a-charakteristika-d/d-78349/>.

# LIST OF FIGURES

<b>FIG. 1: THE TEMPERATURE PROGRESS IN SINGLE-SOLID (NON-INSULATED) WALL AND WALLS WITH THE ADDED LAYERS OF INSULATION .....</b>	<b>18</b>
<b>FIG. 2: HEAT LOSSES OF BLOCK OF FLATS .....</b>	<b>19</b>
<b>FIG. 3: HEAT LOSSES OF A HOUSE .....</b>	<b>19</b>
<b>FIG. 4: ROOF SYSTEM ISOTEC .....</b>	<b>26</b>
<b>FIG. 5: A SIMPLE DIAGRAM OF A HEAT PUMP'S CYCLE .....</b>	<b>33</b>
<b>FIG. 6: HEAT PUMP NIBE F1255 - POWER PERFORMANCE 4 - 16 kW .....</b>	<b>38</b>
<b>FIG. 7: ELECTRICAL FEED OF THE HEAT PUMP .....</b>	<b>39</b>
<b>FIG. 8: THREE-PHASE CIRCUIT BREAKER 16 A .....</b>	<b>40</b>

# LIST OF TABLES

<b>TAB. 1: INTERNAL ROOM TEMPERATURE FOR CALCULATIONS .....</b>	<b>15</b>
<b>TAB. 2: VALUES OF THERMAL RESISTANCE AND HEAT TRANSFER COEFFICIENT .....</b>	<b>17</b>
<b>TAB. 3: HEAT SURCHARGES AS GIVEN BY ČSN 06 0210 .....</b>	<b>22</b>
<b>TAB. 4: VALUES OF THERMAL RESISTANCE FOR OUTER WALL.....</b>	<b>24</b>
<b>TAB. 5: VALUES OF THERMAL RESISTANCE FOR ROOF CONSTRUCTION ELEMENTS .....</b>	<b>24</b>
<b>TAB. 6: VALUES OF THERMAL RESISTANCE FOR CONSTRUCTION ELEMENTS.....</b>	<b>25</b>
<b>TAB. 7: HEAT TRANSFER COEFFICIENT OF ROOF AND FOUNDATIONS CONSTRUCTION .</b>	<b>25</b>
<b>TAB. 8: CALCULATED VALUES OF ROOF WINDOWS .....</b>	<b>28</b>
<b>TAB. 9: VALUES FOR CALCULATION OF GROUND HEAT.....</b>	<b>30</b>
<b>TAB. 10: TOTAL HEAT LOSSES .....</b>	<b>31</b>
<b>TAB. 11: PRICES AND POWER PERFORMANCE OF HEAT FURNACES .....</b>	<b>34</b>
<b>TAB. 12: TECHNICAL PARAMETERS OF NIBE F1255 .....</b>	<b>40</b>

# LIST OF ATTACHMENTS

- 1) **A.01 - MAIN FLOOR PLAN**
- 2) **A.02 - SECOND FLOOR PLAN**
- 3) **A.03 - SIDE - VIEW NORTH**
- 4) **A.04 - SIDE - VIEW SOUTH**
- 5) **A.05 - SIDE - VIEW WEST**
- 6) **A.06 - SIDE - VIEW EAST**
- 7) **HEAT LOSSES OF THE MAIN FLOOR**
- 8) **HEAT LOSSES OF THE SECOND FLOOR**