

VYSOKÉ UČENÍ TECHNICKÉ V BRNĚ
BRNO UNIVERSITY OF TECHNOLOGY



FAKULTA STROJNÍHO INŽENÝRSTVÍ
ÚSTAV AUTOMOBILNÍHO A DOPRAVNÍHO
INŽENÝRSTVÍ

FACULTY OF MECHANICAL ENGINEERING
INSTITUTE OF AUTOMOTIVE ENGINEERING

ANALÝZA AKUSTICKÝCH VLASTNOSTÍ POHONNÝCH JEDNOTEK

ANALYSIS OF POWERTRAIN ACOUSTIC PROPERTIES

DIZERTAČNÍ PRÁCE
DOCTORAL THESIS

AUTOR PRÁCE
AUTHOR

Ing. RICHARD AMBRÓZ

VEDOUCÍ PRÁCE
SUPERVISOR

prof. Ing. VÁCLAV PÍŠTĚK, DrSc.

BRNO 2012



ABSTRACT

This thesis deals with the analysis of the acoustic properties of powertrain. Introduction section contains the theoretical analysis of the physical principles of vibrations and noise and an overview of the current state of solving problems in the area of powertrain design.

Main part of the work describes the engineering design of electrodynamic vibration exciter, design of evaluation of measurement results and also the method of processing the results. Acoustic properties are evaluated by normal velocity of surface vibration.

In the final part of this work, there are presented the samples of the use of the method in practical examples connected with the design of powertrain. The whole solution is a comprehensive method of analysis suitable for quick evaluation of the impact of engineering changes on the acoustic properties.

KEYWORDS

virtual engine, vibration, noise, sound, normal velocity of surface, elektrodynamické excitéry, damping, frequency response function, experimental modal analysis, mobility

ABSTRAKT

Dizertačná práca rieši problematiku analýzy akustických vlastností pohonných jednotiek. V úvodnej časti je teoretický rozbor fyzikálnych princípov vibrácií a hluku a prehľad súčasného stavu riešenia problematiky v oblasti návrhu pohonných jednotiek.

Vlastná časť práce popisuje konštrukčný návrh elektrodynamického budiča vibrácií, návrh hodnotenia výsledkov merania a taktiež spôsob spracovania výsledkov. Akustické vlastnosti sú hodnotené pomocou normálových rýchlostí kmitania povrchu.

V závere práce sú prezentované ukážky využitia metódy v praktických príkladoch spojených s návrhom pohonnej jednotky. Celé riešenie predstavuje ucelený spôsob analýzy vhodný pre rýchle hodnotenie vplyvu konštrukčných úprav na akustické vlastnosti.

KLÚČOVÉ SLOVÁ

virtuálny motor, vibrácie, hluk, zvuk, normálová rýchlosť povrchu, elektrodynamický budič, tlmenie, frekvenčná odozvoivá funkcia, experimentálna modálna analýza, mobilita



BIBLIOGRAPHIC CITATION

AMBRÓZ, R. *Analýza akustických vlastností pohonných jednotek*. Brno: Vysoké učení technické v Brně, Fakulta strojního inženýrství, 2012. 89 s. Vedoucí dizertační práce prof. Ing. Václav Píštěk, DrSc.



DECLARATION

I declare that I have elaborated my doctoral thesis independently, under the supervision of the doctoral thesis supervisor prof. Ing. Václav Pištěk, DrSc., and with the use of technical literature and other sources of information which are all quoted in the thesis and detailed in the list of literature at the end of the thesis

In Brno on 2 August 2012

.....

Richard Ambróz



POĎAKOVANIE

Na tomto mieste by som chcel poďakovať hlavne svojmu školiteľovi prof. Ing. Václavi Píšťekovi, DrSc., za systematické vedenie, ochotu vždy si nájsť čas poradiť a pomôcť a podporu počas celého štúdia.

Taktiež by som sa chcel poďakovať doc. Ing. Pavlovi Novotnému, Ph.D., ktorý ma postupnými krokmi zasvätil do problematiky návrhu virtuálneho motoru, vďaka čomu mohla vzniknúť táto práca.

V neposledom rade patrí vďaka celému kolektívu, za príjemné pracovné prostredie, ochotu a ústretovosť pri realizácii tejto práce.



CONTENT

Introduction	12
1 Current status	13
1.1 Vibration, sound and noise	13
1.1.1 Physical description	14
1.1.2 Effect on the human organism	20
1.2 Virtual engine	23
1.2.1 The procedure of creation of the virtual engine	23
1.2.2 Calculation of vibrations and noise by using a virtual engine	26
1.3 Methods for measuring vibration and noise	30
1.3.1 Measurement of vibration	30
1.3.2 Measurement of sound	32
1.4 Evaluation of the current status	35
2 Aims of the thesis	37
3 Electrodynamic vibration exciter	38
3.1 Principle and division of vibration exciter	38
3.2 Design of vibration exciter	40
3.3 Experimental verification of parameters and properties	45
3.4 The control software	51
4 Experimental modal analysis	53
4.1 Principle of the method	53
4.2 Evaluation of measurement	61
5 Processing and visualization of measurement results and calculation	66
5.1 Processing of FE mesh	66
5.2 Analysis of the velocity of surface vibration	69
5.3 Visualization of results	69
6 Examples of practical application of method	71
6.1 The verification of process for a simple case	71
6.2 The cover of valvetrain of the Zetor engine	75
6.3 Virtual engine	77
Conclusion and discussion	83
References	85
Symbols	88



INTRODUCTION

The issue of computational modeling of noise and vibration of powertrain is the next logical step in the virtualization of the design process. Engine manufactures and also all producers not only in the automotive industry, are trying to change the process of development in to the virtual design as much as possible. This is due to reducing design costs and shortening the time needed to put the product to customers.

Technical requirements for powertrains are now many times contradictory. It is expected: high performance, reliability, low power consumption, basic construction and low production costs as well as reduced emissions.

However, we can say that even if these properties are essential, ultimately the decision to buy a car is often overridden by the user comfort. As for the cars, is one of the parameters of comfort an acoustic convenience, sound while driving, which is generated e.g. from joints of plastic interior parts and also an aerodynamic noise. In the case of trucks and tractors is, in addition to the acoustic expressions, evaluated also the magnitude of the vibration. Certain maximum values prescribe various standards of hygiene. Also, impact on health and with this the corresponding quantity and quality of work done is a significant factor in choosing.

In the passenger cars is the primary source of noise and vibration the drive unit, but also it should not be forgotten the source from the wheels, transmissions, final drives and principally all of the subsystems that transmit power from the engine to the wheels.

Recently, it is more and more talking about alternative fuel vehicles, which should replace the conventional combustion engine and thereby potentially eliminate a key source of noise and vibration. It is difficult to predict the future in this field, as yet recently unimaginable car operated independently by a computer is now a reality. However, it is possible to say with certainty that if the source of energy for movement is the internal combustion engine, hydrogen engine, electric motor or other type,; there always will be the transfer of power to the wheels and thus always will occur larger or smaller vibrations or noise.



1 CURRENT STATUS

This chapter deals with physical principle of noise and vibration and their effects on the human body, description of the current status computational models of engine and methods to measure noise and vibration. The computational model can be of different complexity and hence different requirements for hardware equipment and accuracy of results. It is necessary to verify by measuring the accuracy of the model and which of the details of the real world can be neglected under certain accuracy. Therefore, part of this chapter deals with a method of measuring and evaluating actual power units.

1.1 VIBRATION, SOUND AND NOISE

In terms of physics, the description of vibration, sound and noise is identical. In principle, it is the displacement of particles environment from equilibrium and the oscillations around it. The displacement can be caused by both internal and external dynamic forces. If the particle is in any way put into vibration, this noise is moved by flexible links to neighboring particles [3].

Under the term vibration, it is understood the mechanical vibration mainly of solid particles, which man perceives by touch, or feel with the entire body. Sound is a mechanical wave in a flexible environment, which causes the ear auditory perception. Noise is defined as an unpleasant sound. In the following text, under the term vibration it is understood oscillation of solid parts, which can be perceive only by touch (or whole body) and the term sound respectively noise is considered as oscillations of particles in a flexible environment that revokes auditory perception [3].

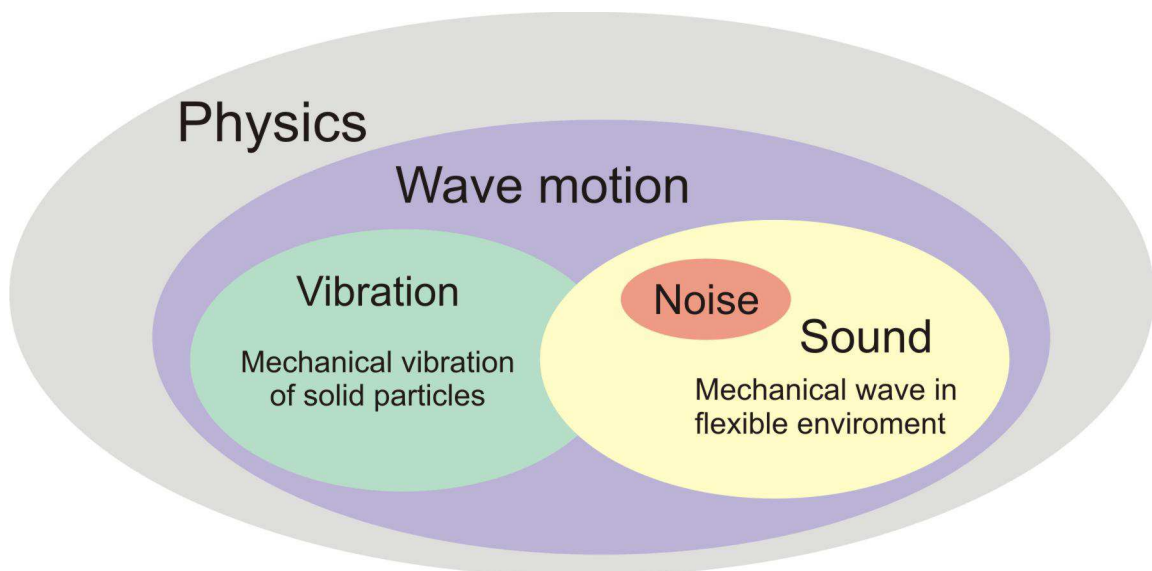

Figure. 1 Vibration and sound as part of physics



1.1.1 PHYSICAL DESCRIPTION

If it is followed the oscillatory motion of a physical element in the environment, it is possible to find its displacement from the equilibrium position, velocity and acceleration at some point in time. These variables are interdependent and thus for the description is sufficient to determine only one of them. It is mostly chosen the one that better describes the properties of the structure or system, or the one for which it is available a suitable measuring apparatus [4].

From the basics of physics, it is possible to define the velocity of vibration as the first derivative of the instantaneous displacement by the time [4]:

$$v = \frac{\partial s}{\partial t'} \quad (1)$$

where: v [m/s] is velocity of vibration,
 s [m] is displacement from the equilibrium position (amplitude of vibration).

Analogously, it is possible to get acceleration by the second derivative of displacement by time, or first derivative of velocity by the time [4]:

$$a = \frac{\partial^2 s}{\partial t} = \frac{\partial v}{\partial t'} \quad (2)$$

where a [m/s²] is acceleration of vibration.

The displacement of parameters that determine mechanical vibrations in time has general displacement in practice, which is physically difficult to characterize. Therefore, waveform of vibration is transferred to the frequency spectrum by Fourier transformation with advantage. Relations between variables are usually derived for a simple harmonic oscillation. The validity of these relationships is then applied on the general oscillation by Fourier transformation. The next will be therefore described only harmonic oscillations [4].

Under harmonic vibrations, it is understood regular, periodic displacement of particles from the equilibrium (rest) position when the instantaneous values of displacement, velocity and acceleration have a sinusoidal waveform [3]. The simplest model for better understanding and performance of harmonic oscillation is a linear oscillator. The displacement of a point mass from its equilibrium results in to imbalance of power, and thus forces that try to bring back the point mass into equilibrium begin to dominate [4].

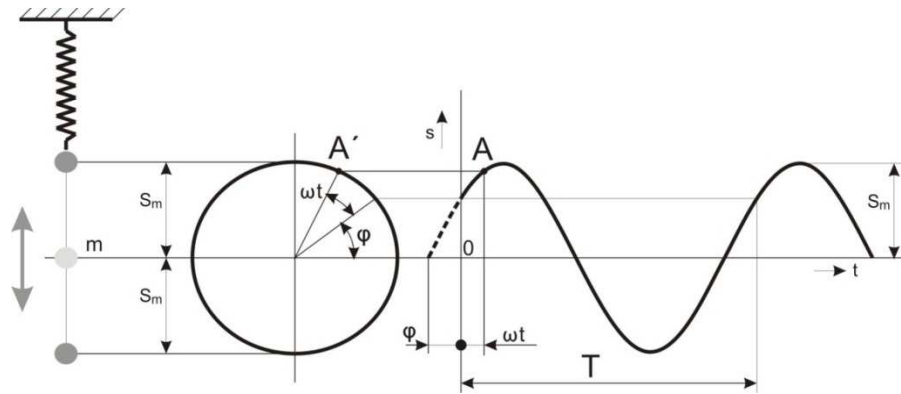

Figure. 2 Linear oscillator and displacement of harmonic oscillation in time [3]

The period of the oscillation (period) T [s], which is defined as the time between two adjacent maximum displacements determines the angular frequency ω [s^{-1}] and thus the actual oscillation frequency f [Hz] of harmonious action. It follows that the oscillation frequency can be defined as the number of complete oscillations per second. If happens that, at the beginning of oscillation, a particle is not in equilibrium, it can be said that periodic action has a phase angle shift φ [rad] [3].

Relations between these variables are interdependent [3]:

$$s = s_{max} \sin(\omega t + \varphi), \quad (3)$$

$$\omega = 2\pi f, \quad (4)$$

$$f = \frac{1}{T} = \frac{\omega}{2\pi}. \quad (5)$$

The formulation $(\omega t + \varphi)$ is called the phase of harmonic variable. If there are two current actions with identical frequency f , but with different phase angles φ_1 and φ_2 , their variance it is denoted as the phase shift $(\varphi_1 - \varphi_2)$ [rad]. Between two actions, it is determined the time difference of which they are mutually shifted [3]:

$$t = \frac{(\varphi_1 - \varphi_2)}{\omega}. \quad (6)$$

As described above, the movement of a particle is possible to describe, except for displacement, by the velocity or acceleration.

It generally applies thus [3]:

$$\cos \alpha = \sin\left(\alpha + \frac{\pi}{2}\right). \quad (7)$$

Substituting into the equation (1) gives:

$$v = \frac{\partial y}{\partial t} = \omega s_{max} \cos(\omega t + \varphi) = v_{max} \cos(\omega t + \varphi) = v_{max} \sin\left(\omega t + \varphi + \frac{\pi}{2}\right). \quad (8)$$



Result of the equation 8 is that the velocity related to the displacement is shifted by harmonic motion by $\pi/2$ [rad], i.e. about 90° . Simple harmonic signal is also described by the formula [3]:

$$v = j\omega s = j2\pi f s, \quad (9)$$

where j is imaginary unit.

Similarly, it is possible to derive from equation 2, relation for acceleration of harmonically oscillating motion [3]:

$$\begin{aligned} v &= \frac{\partial v}{\partial t} = \frac{\partial^2 s}{\partial t^2} = -\omega v_{max} \cos(\omega t + \varphi) = \\ &= -\omega s_{max} \sin(\omega t + \varphi) = a_{max} \sin(\omega t + \varphi), \end{aligned} \quad (10)$$

The acceleration phase compared to phase of velocity is shifted by 90° and therefore against the displacement by 180° , which means that it is with it in anti-phase (Fig. 3). Similarly as in equation 9 it can be also provided for acceleration [3]:

$$s = j\omega v = -\omega s^2, \quad (11)$$

$$v = \frac{1}{j\omega a} = j\omega s. \quad (12)$$

Displacement, as well as velocity, is a vector and therefore is defined by the direction and the value. [3]

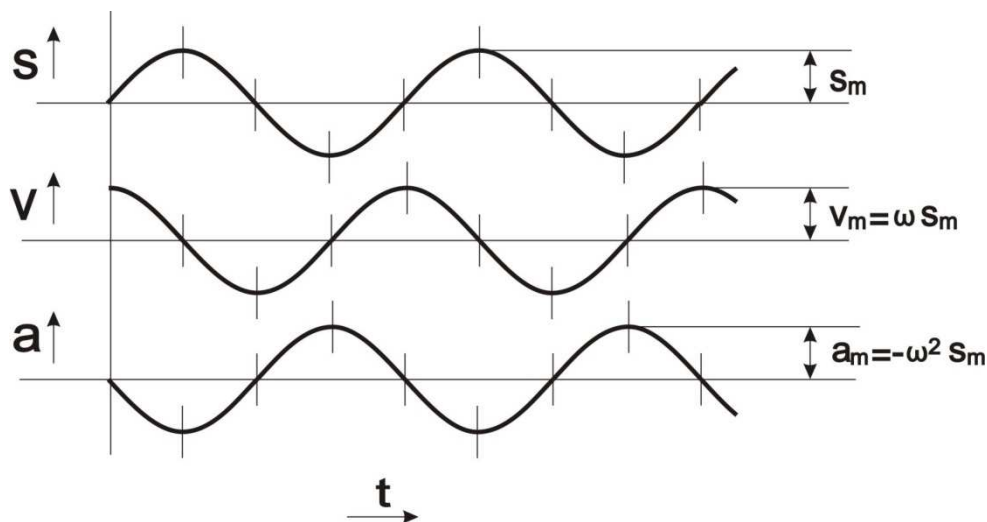

Figure 3 Displacement, velocity and acceleration in harmonic motion [3]

It is important to understand the difference between the velocity of particle vibration and velocity of moving disturbance c [m/s]. The velocity of moving disturbance is the velocity by which is e.g. noise wave spread in air environment. This velocity is dependent on density of the environment, temperature and other variables. In a homogeneous environment is the



velocity of disturbance independent on the displacement, while in the inhomogeneous environment depends on the displacement [3].

Velocity of moving disturbance is also called wave motion. Places in which moving disturbance arrives at the same time with the same phase are connected with area of thought that is called wave front. If the wave front is the geometric place where the maximum value of the environment density was reached, the two adjacent wave front with the same frequency are spaced of a wavelength λ [mm] of emitted disturbance and in velocity of moving disturbance c then is valid [3]:

$$\lambda = \frac{c}{f}. \quad (13)$$

The simplest periodic signal can be represented in time as a sine wave, which determines the waveform of the monitored variable. Generally, waveform of instantaneous values is given by the maximum amplitude by equation 3. Composite signal is a signal with time non-sinusoidal wave. Composite signal can be periodic with a period of repetition T but also aperiodic. Examples of such a periodic signal are e.g. noise, one-off occurrence (slam), but also the speech [3].

The maximum value y or the amplitude (peak value) of the composite signal may not be symmetrical (i.e. the same size of the positive and negative displacement). The sum (formula) is called peak - peak. Sometimes used peak value indicates a larger one of the absolute values of y_{max+} , y_{max-} [3].

By using the Fourier transform, it is possible to decompose each signal into the sum of the set of simple signals. Composite signal can then be folded by the sum of the components of frequencies f , $2f$, $3f$, etc. For these harmonic components, it is distinguished the fundamental frequency f and the other higher (f , $2f$, $3f$). Periodic signals contain the different higher harmonic components (do not have to form a continuous series) with varying amplitude and phase. Aperiodic signals consist of an infinite set of different frequencies, in the extreme case of all the lying infinitely close together. Description of the composite signal by using simple signals is called the frequency spectrum, where on the horizontal axis is applied frequency (usually in logarithmic scale) and on the vertical axis values of the monitored variable usually effective value or in dB levels (which may be linear or logarithmic) [3].

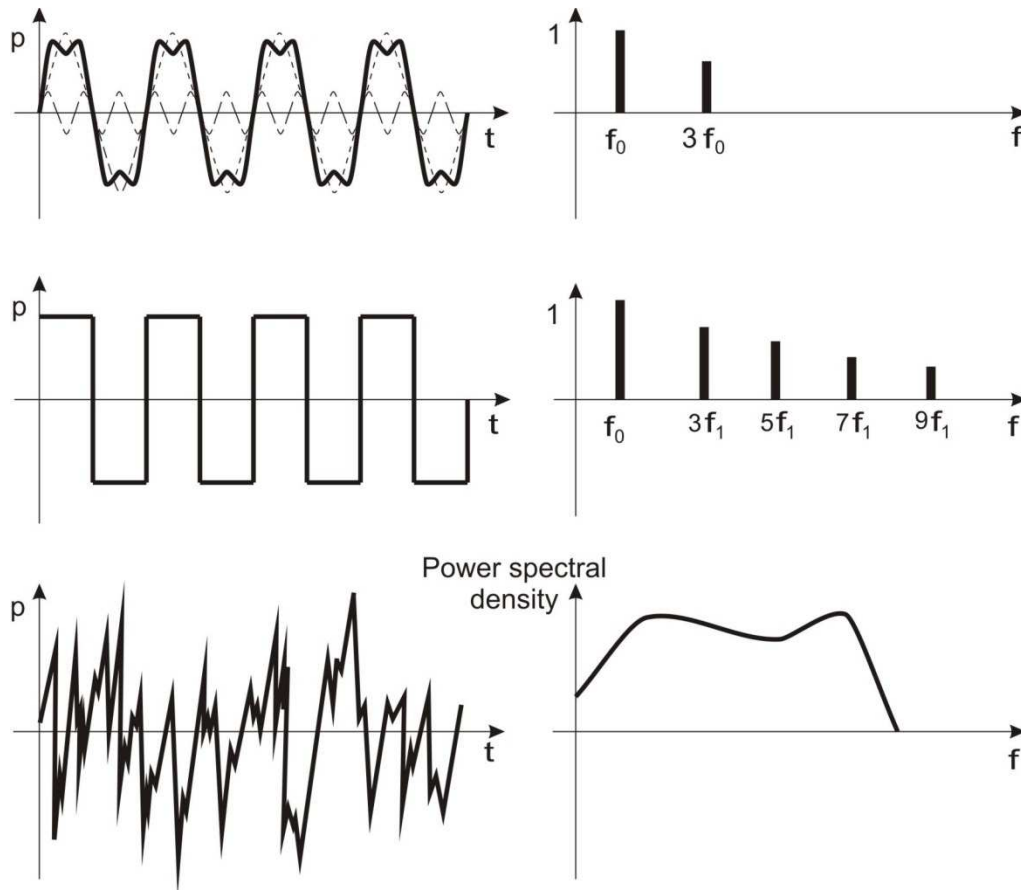

Figure. 4 Spectral analysis illustrated [3]

In practice, for the ordinary calculations it is not used the amplitude, but more effective value y of the interest variable, which is a rate of energy that signal carries. Generally, the effective value of the variable is defined by [3]:

$$y_{ef} = \sqrt{\frac{1}{T} \int_0^T y^2 dt}. \quad (14)$$

The effective value of sine wave (but only of the sine wave) is determined [3]:

$$y_{ef} = 0,707y_M. \quad (15)$$

In expressing the individual variable are often instead of absolute values used levels of variables. This is due to the fact that tactile and auditory perceptions are basically adjusted by a logarithmic scale. For example, acoustic pressure of the audible range of overlaps 7 decades what would clutter the chart. From these reasons is the fact that perceptual values are expressed in the logarithmic scale to the specific reference value [3].

The general calculation of the level variable can be written [3]:

$$L_y = 10 \log \left(\frac{y^2}{y_0^2} \right) = 20 \log \left(\frac{y}{y_0} \right). \quad (16)$$



For reference values of used parameters were set the following values [3]:

Tab. 1 Reference values

Variable	Reference Value
Acoustic Pressure	$2 \cdot 10^{-5}$ [Pa]
Acoustic Power	$1 \cdot 10^{-12}$ [W]
Acoustic Intensity	$1 \cdot 10^{-12}$ [W/m ²]
Amplitude - non-standardized	$1 \cdot 10^{-9}$ [m]
Velocity	$5 \cdot 10^{-8}$ [m/s]
Acceleration	$1 \cdot 10^{-6}$ [m/s ²]
Force	$1 \cdot 10^{-6}$ [N]

There must be environment composed of material particles to the spread of vibration, and it is characterized by compressibility. It is held due to power impact of driver oscillation, where the disturbance is spreading from driver particle by velocity c . During the spreading it occurs the influencing the linear spreading by impact of reflection from obstacle, bending of environment with varying properties or by refraction in the transition from one environment to another one with different properties. Variation of wave impedance environment determines the rate of reflection, bending and refraction [3].

Reflection occurs during the moving of wave disturbance against an obstacle. Intensity of the reflected wave depends on the absorptive properties of the reflecting surface and the wavelength of the signal. The vibration of structures leads to reflection at the interface of materials with different properties (especially modulus of elasticity in tension). Therefore, as an effective tool against the transmission of vibration are used composite (layered) materials (constructions) [3].

Reflection of sound causes before an obstacle the concentration of sound energy, which leads to increase of sound pressure. On the other hand behind an obstacle, there is acoustic shadow, where on the reverse (back) surface of the obstacle is decrease of acoustic pressure about so much dB how much the acoustic pressure was increased before an obstacle [3].

When a wave passes from one environment to another, it leads to the refraction. It is true that if in the new environment, velocity of moving disturbance is higher than in the initial environment the wave is refracted towards a perpendicular to the contact area. If the angle of incidence exceeds a certain value, (limit angle) there is total reflection [3].

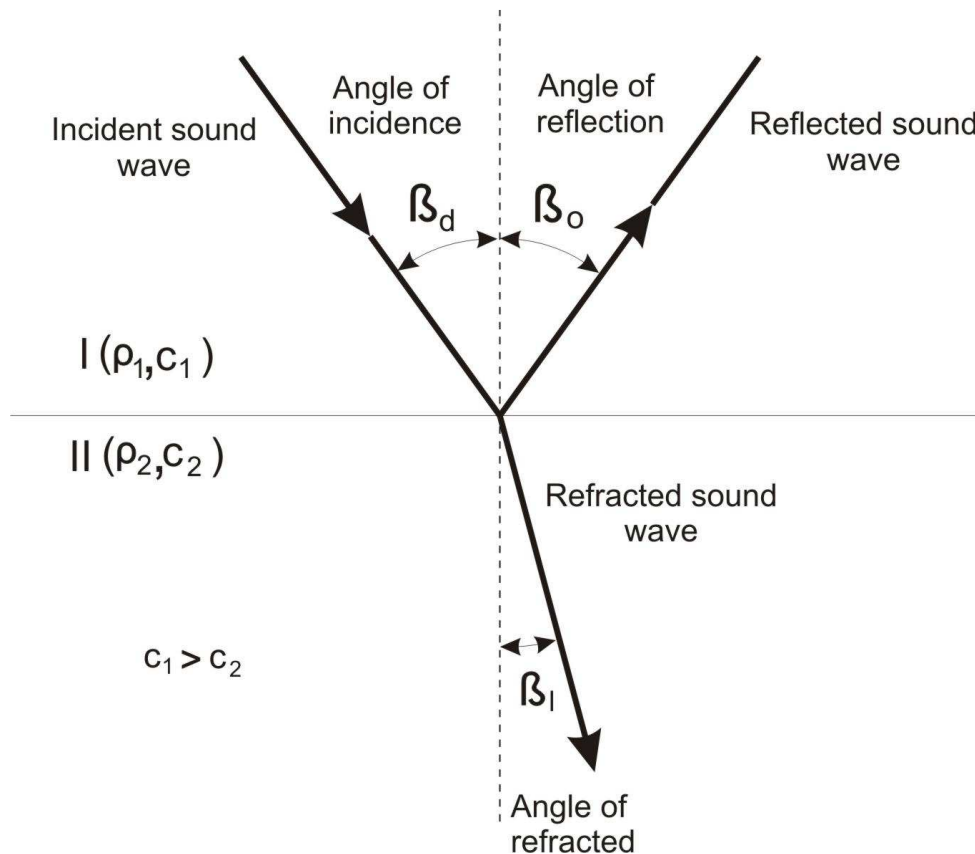

Figure. 5 Refraction and reflection of a ray path at planar boundary [3]

The spread of sound or vibration in the environment leads at the molecular level to the loss of transmitted energy that is known as damping - absorption. In the case of transmission of vibration in the solid parts is damping depended on the materials and the geometric shape of the body. Damping is during the sound transmission mainly depended on the frequency and humidity of the environment [3].

The issue of vibration and noise is elaborated in detail in [3] [4], [5], [6], [7] and therefore in this work was used introduction to the problem only at the most basic needed level, necessary for its content.

1.1.2 EFFECT ON THE HUMAN ORGANISM

The human body perceives vibration through the system that provides an overall psychosomatic sensitivity. It is influenced by many factors. It is a complex physiological and psychological sensation mediated by a large number of different receptors. Induced impulses are transmitted by the central nervous system to the brain, where are integrated and where occurs also the subjective perception that is determined by impact of vibration. Size of subjective perception is determined not only by frequency but also by the velocity of oscillatory motion [3].

Perception of vibration with a frequency below 15 Hz is determined by the function of a vestibular apparatus. The vestibular apparatus specifies a response of human to linear or angular acceleration of head and overall vibration of the body and its position in space.



Perception on low frequencies is also mediated by receptors in the joints, tendons and muscles. Vibrations at frequencies below 15 Hz are perceived by receptors on the pressure that are located under the skin [3].

Exposure to intense vibration is associated with unpleasant subjective sensation of discomfort, which can be considered both from the physiological and psychological perspective. Prolonged exposure can cause permanent damage to health [3].

Mechanical vibrations can affect the whole person (vehicles) or locally (jackhammers, hand drills, etc.) [8]. Depending on the frequency and amplitude of vibration and also on the place of impact of the human body, often occurs organs dysfunctions and failure of functional systems of human [8]:

- overall oscillations with a frequency of 0,1 Hz to 0,3 Hz are primarily affecting vestibular function. These disorders are expressed as depression accompanied by twisting of the head, stomach problems, disorderly movement coordination, disorientation and psychophysical illusions,
- up to 1 Hz man perceives oscillations mainly by eyes,,
- up to 10 Hz oscillations with higher amplitudes are perceived by the vestibular system, which registers a change in position,
- above 20 Hz man perceives oscillations by hearing.

The effect of vibration on the human body is causing a forced oscillation of certain parts of the human body or the whole body, i.e. the resonance occurs. Knowledge of these phenomena is essential for the proper construction of various machines and equipment with which is a person in immediate interaction. Knowledge of the mechanical properties of the human body is required to the modelling human body as a mechanical system. The human body acts as a mechanical system with many degrees of variance. Used discrete models can be applied up to the frequency of 100 Hz [8].

Resonance frequencies of the individual parts of the body [8]:

- the fundamental resonance of the body in a vertical direction is 3 Hz to 6 Hz,
- the fundamental resonance of the body in a horizontal direction of 3 Hz.

As a result of vibration, there is a dynamic stress of the human body parts and internal organs. This results in deterioration of the circulatory system of the human body manifesting first as fatigue and later as the vegetative nervous system disorders [8].

The effects of vibration and shock on humans are monitored with regard to ensuring the comfort, health or work performance. According to this, appropriate levels of vibration are also determined. The maximum permissible limits, the method of measurement and determination of exposure and all other sanitary requirements are regulated by appropriate public notice and in practice, shall ensure compliance with regulations.

As mentioned above, sound is vibration that is spreading in elastic substances (gases, liquids). The human body has for the perception of sound an independent organ, the ear. The ear from a technical point of view as a device for sound perception is quite complicated and has the nonlinear properties of all variables by which can be sound measured and described. [3]

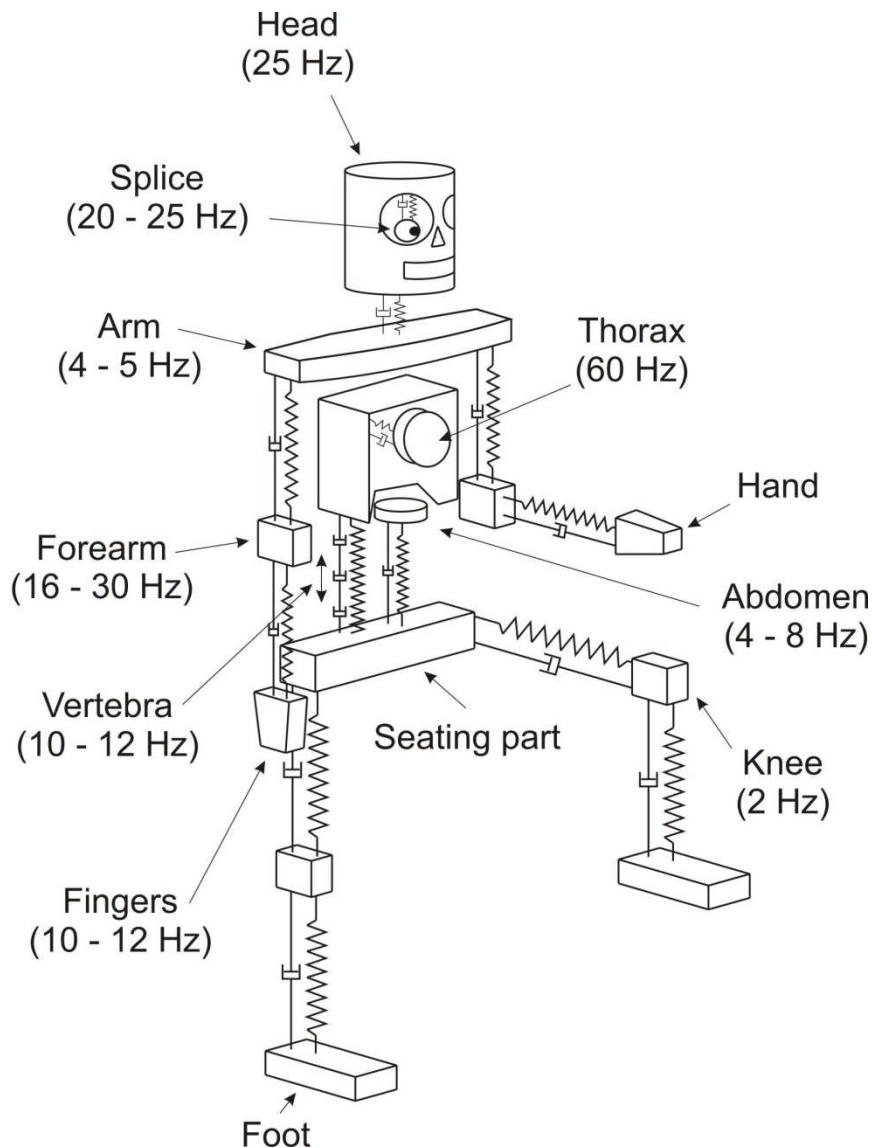

Figure. 6 Natural frequencies of human body organs [8]

The ear is able to record vibrations in the range 20 Hz to 20 kHz. Determination what is sound and noise is not exactly possible because it is a subjective evaluation of each person. What is normal for one person may cause unpleasant feelings to another person. For vibration, as well as for sound, it is true that it has essential importance to human health, psychological well-being and work performance. If a person is exposed to too much sound exposure, this can cause permanent damage to the ear or a complete loss of hearing. Therefore, the relevant standards and regulations set limits of noise that are monitored as the limits of vibrations and their exceeding is strictly penalized.

It follows from the above that for recording noise by ear it is necessary to meet the three conditions. Essential is that there must be a source of vibration. The second condition is that the vibrations have to be in a certain frequency range. The last condition is that the source of vibration should be able to vibrate the environment (usually air) to the rate that the ear will be able to record it.



The ear is from a technical and metrological point of view sensor of pressure. All around us is a certain air pressure and the ear is able to record its difference. So it is not absolute, but relative sensor of pressure and hence records the difference between pressure of environment and pressure induced by mechanical oscillation. More about sound and noise, its description, evaluation and impact on humans is mentioned in [3], [4], [5].

1.2 VIRTUAL ENGINE

Virtual engine is a complex computational model that includes all essential phenomena, and by it can be predict properties of the real motor or the impact of various treatments. The main part of the virtual engine is crank mechanism, which is the source of the forces acting on the engine block and thereby the source of generated vibration and noise. [1]

There are several models of the virtual engine with varying degrees of implementation of real physical processes. In consideration of the current level of computing, it is used a model, which in itself contains properties and effects of the crankshaft, valve train, vibration dampers, the injection pump. This basically represents all the engine subsystems. Development in this area is currently focused on more accurate and detailed description of the mutual interactions of these subsystems. This means, for example, a detailed description of the properties of sliding bearings, nonlinear models of gearing with incorporating time-variable stiffness of teeth, a detailed model of contact of piston rings with the wall of the cylinder and other.

1.2.1 THE PROCEDURE OF CREATION OF THE VIRTUAL ENGINE

Initial information for a design is performance requirement, the number of cylinders, consumption and the expected build-up options. Design and development of new powertrain does not begin so-called "on greenfield" but it is assumed that there are already some experience and a knowledge database.

These initial data together with experience are the basis that is used by a design. The design is realized by CAD systems, and the result is a three-dimensional model that describes the layout and concept of the engine. These data are used for subsequent analysis and providing information such as mass properties, moments of inertia, gravity and other Figure 7.

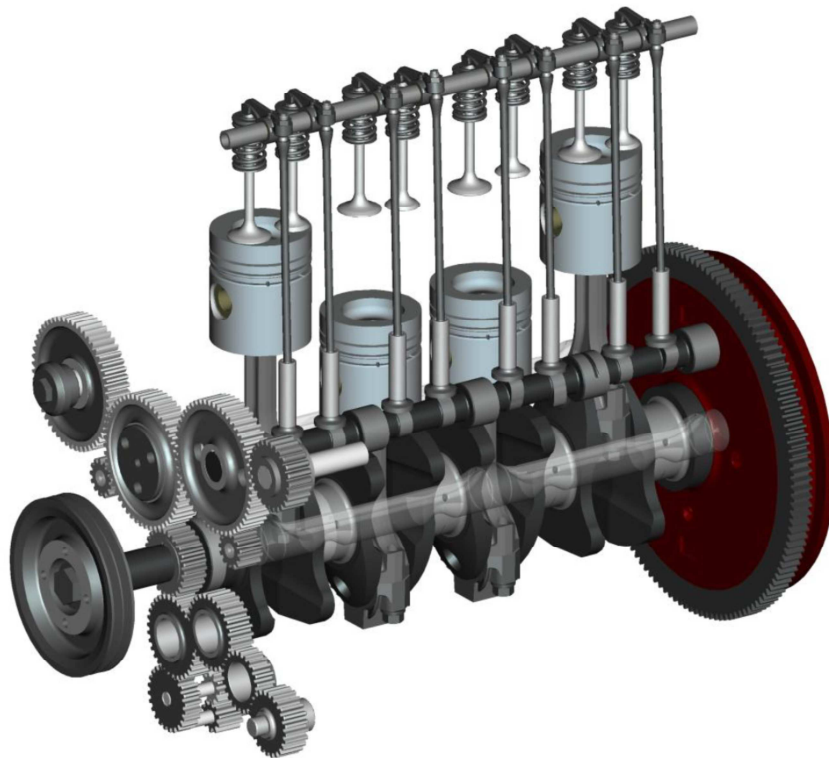

Figure. 7 CAD powertrain model [2]

After the creation of the three-dimensional model, data are used for analysis of physical properties of power unit. By this, it can be imagined two ways that are linked together so that it is not possible to determine their order and priority. It is a finite element analysis (FEM - Finite Element Method) and simulation of mechanical systems (MBS - Multi Body System).

Whereas the geometry of the drive unit is complex, it is not possible in the calculations of mechanical properties and stress to use simple analytical methods, and it is necessary to discretize the geometry on a finite number of small elements. The input is thus discretized three-dimensional model of engine unit.

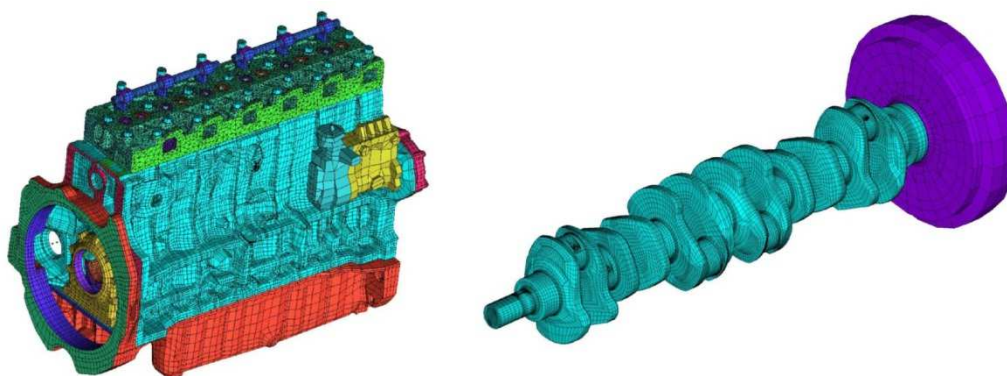

Figure. 8 FE model of engine assembly and part [1]



The output can be a modal analysis, a lifetime analysis of individual components or the whole engine, size of mechanical stress and also background information for the dynamic simulation in MBS such as e.g. mass matrix, stiffness matrix and the first natural frequencies and forms.

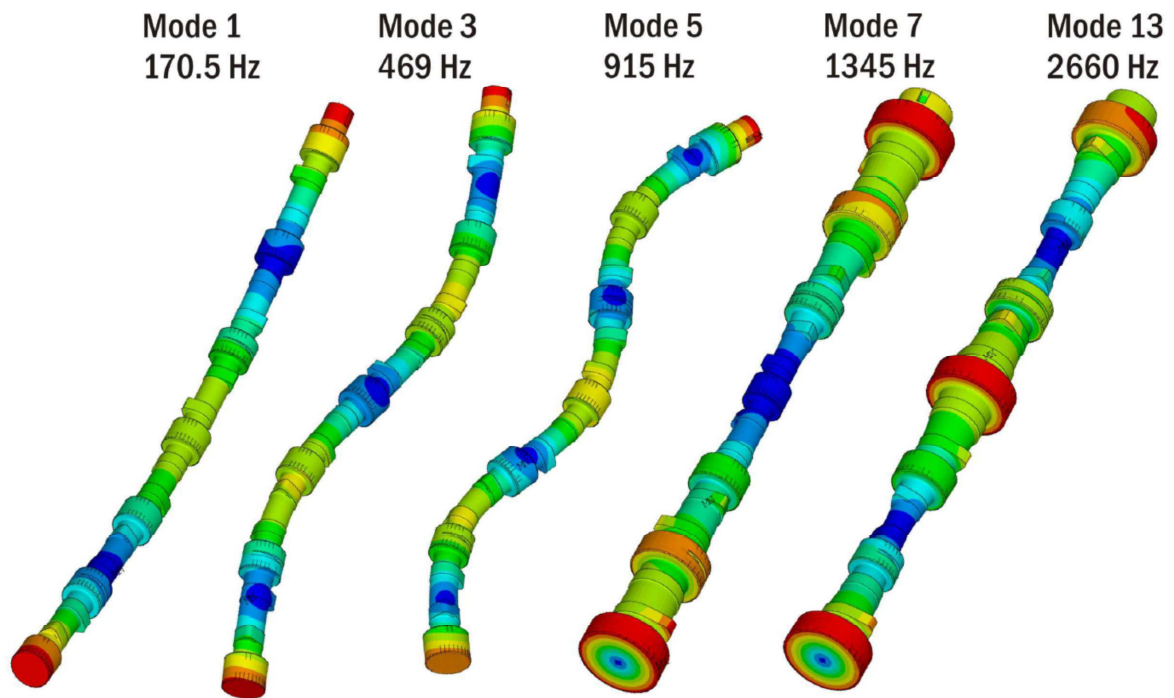

Figure. 9 Example of FE simulation results [1]

Mutual dynamic interaction of individual components in the running engine can not be simulated using FEM programs. These simulations are performed in specialized MBS software. Data for spatial representation of the geometry is possible to obtained either directly by export from the CAD program, or by export of FEM.

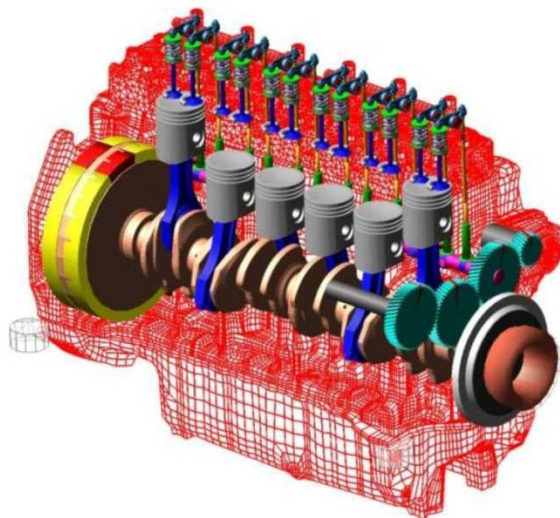

Figure. 10 MBS model[1]



Using CAD, FEM and MBS analysis allows obtaining realistic and accurate information on the dimensions of the drive unit, its dynamic characteristics and important parameters, and also information on method of stress and operating life.

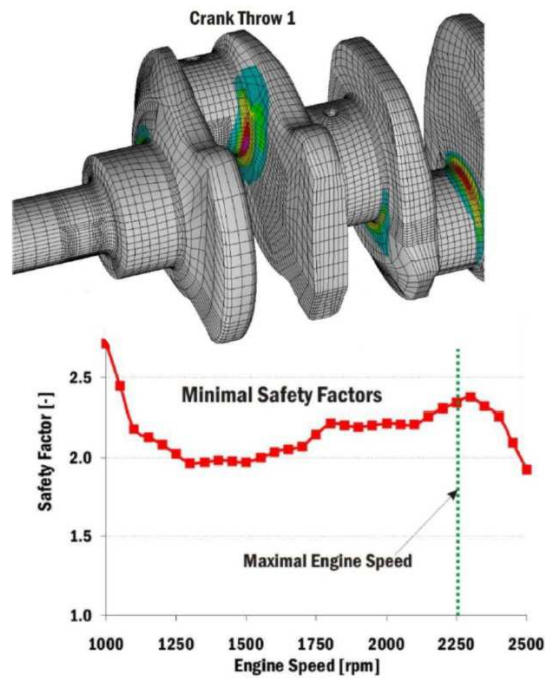

Figure. 11 Example result of safety analyses [1]

1.2.2 CALCULATION OF VIBRATIONS AND NOISE BY USING A VIRTUAL ENGINE

The ones of many possible outputs of simulation of virtual engine are the values of individual coordinate components of velocity at nodal point in FE mesh. These values together with the FEM model can be used to describe and analyse characteristics of the power unit.

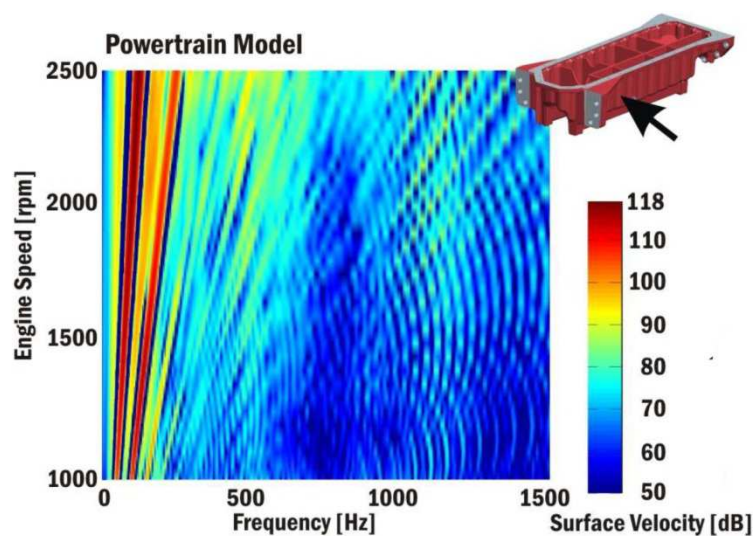

Figure 12 Campbell diagram [1]



The next step in creating virtual engines and evaluating of acoustic emission is determining the level of the noise emitted by the engine. There are several calculation methods that differ in the obtained results but especially in complexity of calculating. A discretization of the boundary surface it seems to be the optimal. The discretization bases on the approximation of the boundary of the body surface and in the selection of appropriate interpolation relation for boundary pressure and normal velocities [8].

For surface discretization [8]:

$$S \approx \tilde{S} = \sum_i S_i, \quad (17)$$

where S_i is area of i -th element of surface.

For the vectors of acoustic pressures and normal velocities at points on the surface of body, given by vector X it is valid:

$$\mathbf{p}(X) = \mathbf{N}_p(X)\mathbf{p}, \quad (18)$$

$$\mathbf{v}_n(X) = \mathbf{N}_v(X)\mathbf{v}_n, \quad (19)$$

where \mathbf{p} , \mathbf{v}_n column vectors of pressures and normal velocity of node and \mathbf{N}_p , \mathbf{N}_v are matrix of interpolation functions.

Then is valid a relation between the normal velocity at points X and gradients of the acoustic pressures [9]:

$$\frac{\partial \mathbf{p}(X)}{\partial n_x} = -j\rho\omega\mathbf{v}_n(X). \quad (20)$$

The relation between the vector of acoustic pressure and normal velocities at nodal points of boundary elements in a matrix form after the adjusting appears as following [8]:

$$\mathbf{D}(k)\mathbf{p} = -j\rho\omega[\mathbf{C}^T + \mathbf{B}^T(k)]\mathbf{v}_n, \quad (21)$$

where matrix $\mathbf{D}(k)$, $\mathbf{B}(k)$ are frequency dependent. Matrix $\mathbf{D}(k)$ is symmetrically, but $\mathbf{B}(k)$ is non-symmetrical. Both are complex.

Equation (21) can be simplified to the form:

$$\mathbf{D}(k)\mathbf{p} = \mathbf{H}(k)\mathbf{v}_n. \quad (22)$$

Matrix $\mathbf{D}(k)$ and $\mathbf{H}(k)$ are functions of frequency and form of the body (or structure), but they are independent on the properties of the structure [8].

From equation (22), it can be evaluated acoustic pressures in the nodes of boundary elements:

$$\mathbf{p} = \mathbf{D}(k)^{-1}\mathbf{H}(k)\mathbf{v}_n. \quad (23)$$

If we know acoustic pressure and normal velocity in the nodes, then can calculate acoustic pressure any point in space. [8]:



$$\mathbf{p}_f = \mathbf{a}_f^T \mathbf{p} + \mathbf{b}_f^T \mathbf{v}_n, \quad (24)$$

where \mathbf{a}_f , \mathbf{b}_f are vectors of coefficients influence, which are a function of frequency and geometry of the structure.

The relation is derived using basic Helmholtz equation for a point source. The analysis by boundary elements provides the ability to predict the emitted noise from the structure, the response of closed acoustic systems, transmitted losses in a complex system by using simple analytical resources. Boundary element methods are related only to the acoustic system [8].

There are two used methods for solving boundary elements:

- Direct method
- Indirect method

The direct method uses acoustic pressures and velocities of surface vibration of the structure as the primary variables for further calculation of emission of acoustic energy into the airspace.

The indirect method uses the difference of pressures and velocities along the element as the primary variables. It solves the emitted energy and the internal response all at once. However, it is difficultly to apply due to the problems with transmitted losses, and for models with holes or thin ribs [8].

In calculating the acoustic properties of power trains, it is most commonly used indirect method. This method uses the so-called gradient of potentials, which are intended by the differences between external and internal values of the acoustic pressure and their normal derivatives.

These are then defined by [8]:

- jump of pressure or also double layer potential and it is determined by the difference of pressures on the outside and the inside surface:

$$\mu = p^+ - p^-, \quad (25)$$

- jump in the normal derivation or single layer potential and it is determined by the difference of the external and internal normal derivative of the pressure on the surface:

$$\sigma = \frac{\partial p^+}{\partial n} - \frac{\partial p^-}{\partial n}. \quad (26)$$

In the indirect method at any point in the outer V and inner V space are the acoustic variables evaluated as a function of these two types of potentials.

Applicable boundary conditions (it possible to use only one of them) [8]:

- the intended pressures on the surface
- the intended normal velocities of surface



- the normal admittance on the surface (mixed boundary conditions, i.e. the relations between the pressure and normal velocity)

It follows from the above that in consideration of the applicable boundary conditions is this method suitable for this work (normal velocity on the surface). These boundary conditions can be formulated in the form of both potentials. The first step is the calculation of the unknown potentials. For this purpose, it is necessary to use a variational method, because collocational method is useless due to arising singularities in the role [8].

It is obvious that the pressure p , it is not possible to differentiate near the boundary surface S because there is a discontinuity or jump in pressure at the same place. It must be fulfilled the following relations [8]:

$$\int_V (\nabla^2 p + k^2 p) \Psi dV = \int_V (\nabla^2 \Psi + k^2 \Psi) p dV, \quad (27)$$

for all exist functions Ψ , which are possible derivation

Relation on the right side is defined by potentials. Then it is used the convolution of these results together with the basic Helmholtz equation for a point or linear source. The procedure further leads to an integral formulation for the pressure p at any point in space V . Thus, it is obtained the following relation [8]:

$$p(X) = \int_S \left[\mu(Y) \frac{\partial G(X, Y)}{\partial n_Y} - \sigma(Y) G(X, Y) \right] dS(Y), \quad (28)$$

where point $X \in V/S$, point $Y \in S$.

If both types of potentials (formula) on the surface S are known, then the acoustic pressure $p(X)$ at any point X in space V is possible by (28) evaluate. At the same time, point X must be on the outside or the inside of surface [8].

For the discretization of the problem, it can be written:

- for the surface

$$S \cong \sum_j S_j, \quad (29)$$

where $j = 1, 2, \dots, m$ (number of border elements).

- for potentials at any point of the surface on the basis of the values at the nodes of discretized surface

$$\mu = N_\mu \cdot \bar{\mu}, \quad (30)$$

$$\sigma = N_\sigma \cdot \bar{\sigma}, \quad (31)$$



$$\nabla\mu = \mathbf{B}_\mu \cdot \bar{\mu}, \quad (32)$$

where $\bar{\mu}, \bar{\sigma}$ vector of potentials in nodes N_μ, N_σ interpolation functions and \mathbf{B}_μ content Cartesian derivation of interpolation function N_μ .

Then is the resulting equation for the acoustic pressure at point X of the internal or external area as following:

$$p(X) = \sum_j \int_{S_j} \left[N_\mu(Y) \bar{\mu} \frac{\partial G(X, Y)}{\partial n_Y} - N_\sigma(Y) \bar{\sigma} G(X, Y) \right] dS_j(Y), \quad (33)$$

where, in relation (33) is $G(X, Y)$ Green's function between points X in space V and points Y on the surface S .

In the previous text, it is given only a basic insight into the calculation of acoustic parameters, which indicates how this issue is now resolved. Closer and more detailed description of the calculation of acoustic parameters and properties it is given in [10].

1.3 METHODS FOR MEASURING VIBRATION AND NOISE

The last step in the development of power train is the verification of the expected values of the studied parameters. This is done by measuring the already finished physical prototypes. Measurement is essential not only to verify the examined values, but also to verify the computational model and also to determine the input unknown constants. Such relevant constant in the area of vibration and noise is e.g. damping, which can not be determined analytically, but only by measuring and its value impacts radically on the calculation results.

Although the physical description and principle of vibration and noise is identical, there are used different variables for measuring. Variables base on how the vibration and noise effect on humans and how they are able to perceive.

1.3.1 MEASUREMENT OF VIBRATION

For a description of the vibration, there are used the physical variables as displacement, velocity and acceleration. Selection of variable, which will be measured and thus the choice of the sensor, it is determined by the properties of a measured device, the expected frequency range and complexity of the measured signal (complex oscillations with a large number of frequency components).

Experience show that the best scale of threat of mechanical vibration is the total effective value of the frequency range from 10 to 1000 Hz. The probable explanation is that a certain value of velocity corresponds to a certain value of energy, and thus from the energy point of view is the same weight placed on the components with low and high frequency. The spectrum of vibration machines in practice is more or less flat. In the narrow-band



measurements, it is the choice of the measured variable expressed only by a tendency of the resulting curves Fig. 13. [12]

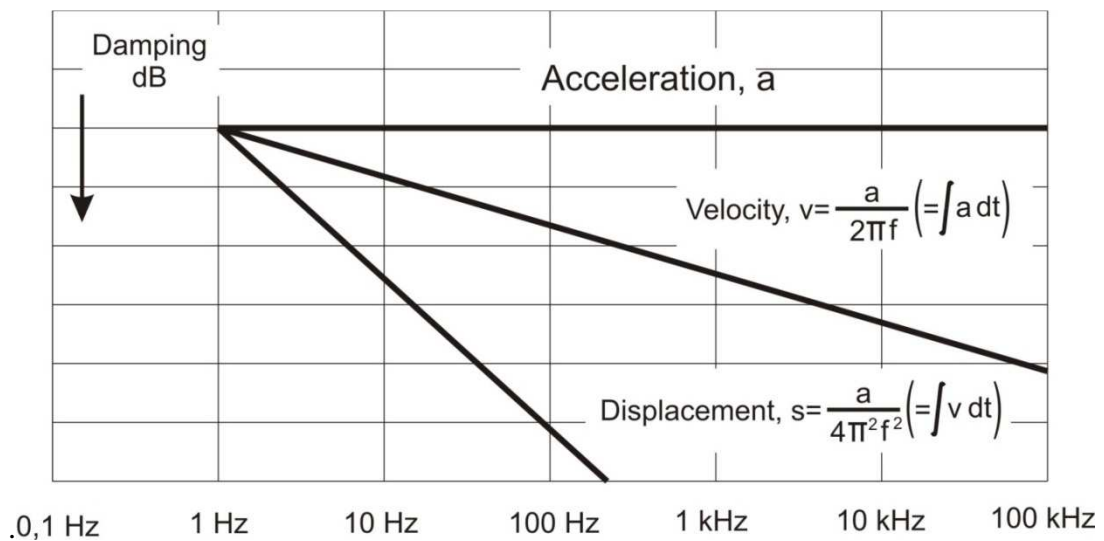

Figure. 13 The course of measured values, depending on the frequency [11]

It follows that, in terms of optimal utilization of the working dynamic range, it is appropriate to choose such a measured variable, which has in the specified frequency range the flattest and consistent behaviour. Therefore, it is usually chosen the velocity or the acceleration. [12]

When measuring high frequencies it is usually chosen acceleration measurement because of the highlight of high frequency components for the measurement and analysis. [12]

Typical characteristic of the mechanical systems is that the larger displacements are in the area of lower frequencies. Therefore, the measurement of displacement has limited importance in general examination and analysis. This variable is essential there, where it is necessary to take into account the clearance and tolerance of components. Displacement is also a key factor, which characterizes the imbalance. [12]

Sensors for all characteristic variables describing the vibration can be divided according to various criteria. Primary and foremost it is, what a variable it is measured (displacement, velocity and acceleration). Another dividing is the necessity of connection with the measured object and so on contact and contactless sensors. [12]

Contact sensors are those sensors, which have to be in some way mounted to the surface of the examined object. The choice of method of mounting depends on what frequency range will be measured, but also on the environment and characteristics of the examined object. Methods for fixing sensors and frequency response are shown in Fig. 14. [12]

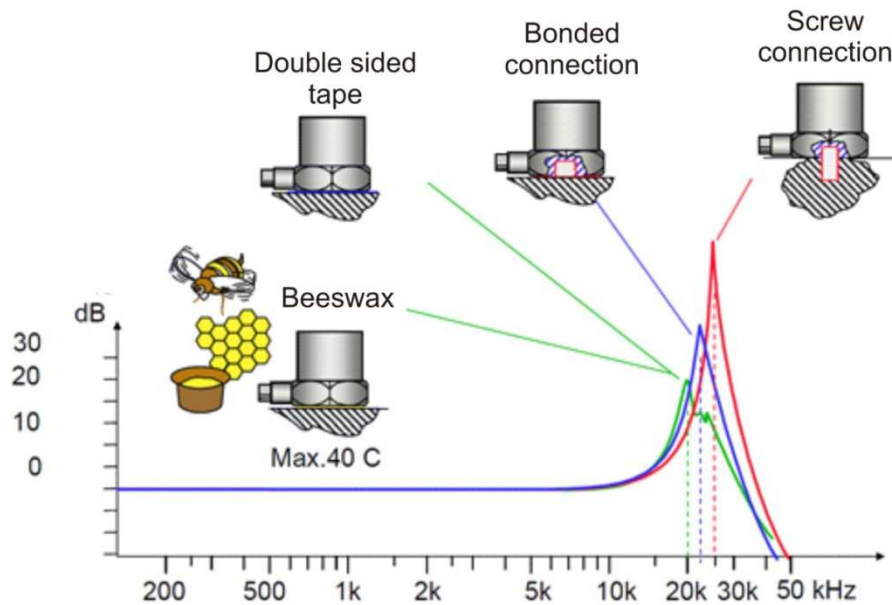

Figure 14 Method of mounting of sensors and frequency range [11]

The contact sensors can then be subdivided according to the structure, according to what mechanical stress is transferred to charge, the frequency range, maximum of measured values etc.

However, there are applications where the using of contact sensors, and thus the adding other masses in to the system, would have a significant impact on measurement results. Also, it is not always possible to fix the sensor on the surface of the body. These weaknesses are solved by method of laser vibrometer.

It is a contactless, highly accurate and rapid method of vibration measuring. It is used the so-called Doppler effect, when the velocity is calculated from the frequency shift transmitted and received signals. By this method, it can be measured with accuracy of the tenth micron, speeds up to 500 mm/s, distance within 30 meters from the measured object and also through the transparent material (glass, plexiglass, etc.). [12]

1.3.2 MEASUREMENT OF SOUND

The sensors of sound are actually relative sensors of pressure. Using a single sensor of sound (microphone) to evaluate the sound pressure level is the most appropriate, in terms of construction, using and the legislative background in assessing. However, measurement of acoustic pressure has already from the principle some weaknesses. The main is that the pressure is not a vector and also that it is not an energy variable. Finally, measurement of sound pressure gives only information about its values at measured point and not about the characteristics of the sound source. [13]

These weaknesses can be remedied by using a sound intensity probe. Its principle bases on measurements of pressure using two microphones. Most often are these microphones oriented towards each other. Acoustic intensity is a significant energy variable, which is suitable for audio description and determination of acoustic performance. Also, measurement of intensity



of sound allows a better mutual comparison of individual sources and is the basis for mapping the sound field. [13]

At present, in the area of the mapping and identification of sound sources are gaining measurement methods that result is not only time or frequency dependence at some measured points but especially visualization of measured variable. These methods include NAH (Near-Field Acoustics Holography), beamforming and inverse methods, e.g. IBEM (Inverse Boundary Element Method). Sometimes NAH and beamforming refer to one name as the acoustic camera. [13]

The principle of measurement bases on the using of several sensors, which are in defined way oriented in area (microphone array). Subsequently, the signal from the sensors it is processed and the measured variable displays as 2D image obtained by the camera or converts in to nodal points in the finite element mesh of the model.

NAH and beamforming are the methods of sound localization, which differ in location of the microphones during the measurement. NAH, as the name suggest, it is used for near field. The distance of microphones from the measured object must by half the wavelength of maximum frequency. The disadvantage is that the measured object must have parallel surface with a field of microphones. Thus, the measurement of large objects is problematic. However, this method gives accurate results of the sound source. [14]

Unlike NAH, beamforming is used for measurement in the far field. However, it is impossible to determine so much in detail what is the source of the noise, whereas a variety of reflections from the measured object are affecting measurement in greater extent. However, this method enables to determine the sources of larger objects (the whole car, buildings, football stadiums, cities, ..). [14]

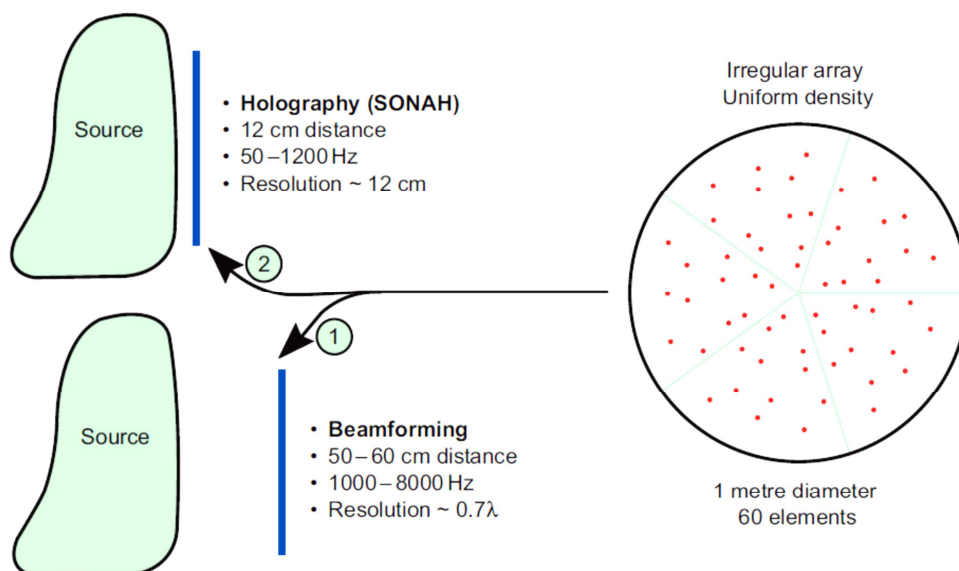

Figure. 15 Difference between beamforming and holography [15]

Therefore, for the locating of sound it seems to be reasonable to use a combination of both methods. The first step is to determine the approximate source of sound using beamforming and then specify the location using the NAH.

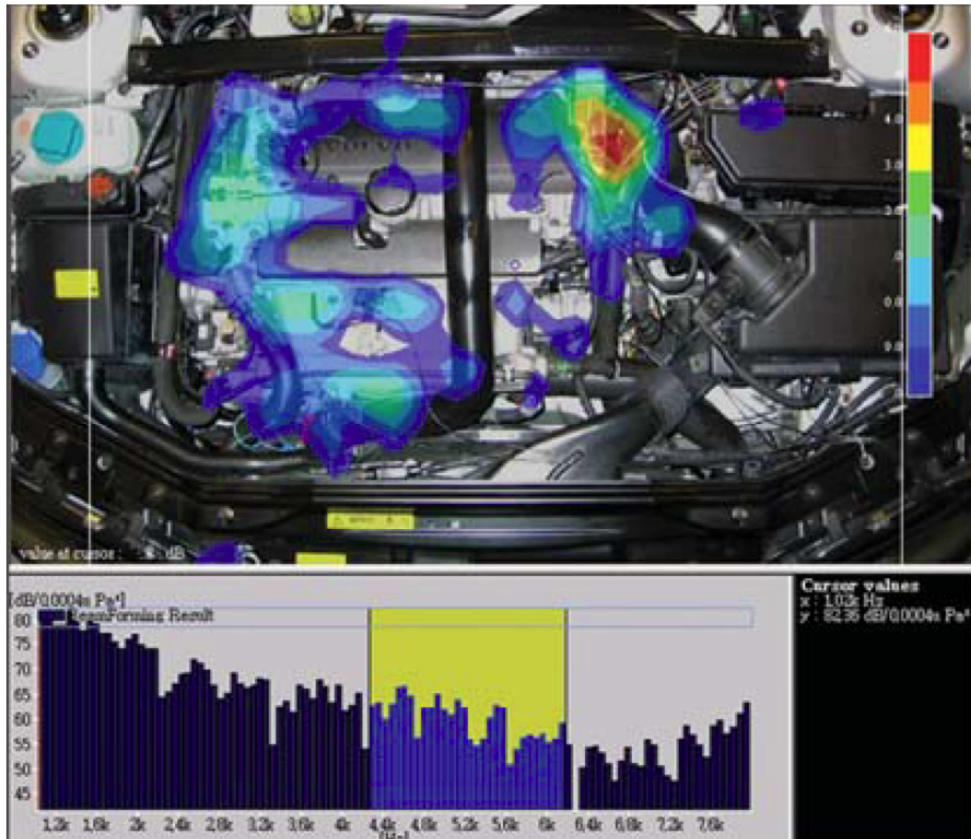

Figure. 16 Example of measurement with acoustic camera [15]

Inverse methods base on the principle of converting the measured pressure to normal velocities at nodal points in the finite element mesh. One of the most frequently used methods is IBEM. This method enables more accurate to verify a computational models and the results of the calculation, as the input for the measurement is a finite element mesh and therefore is possible to compare results at the same points [14].

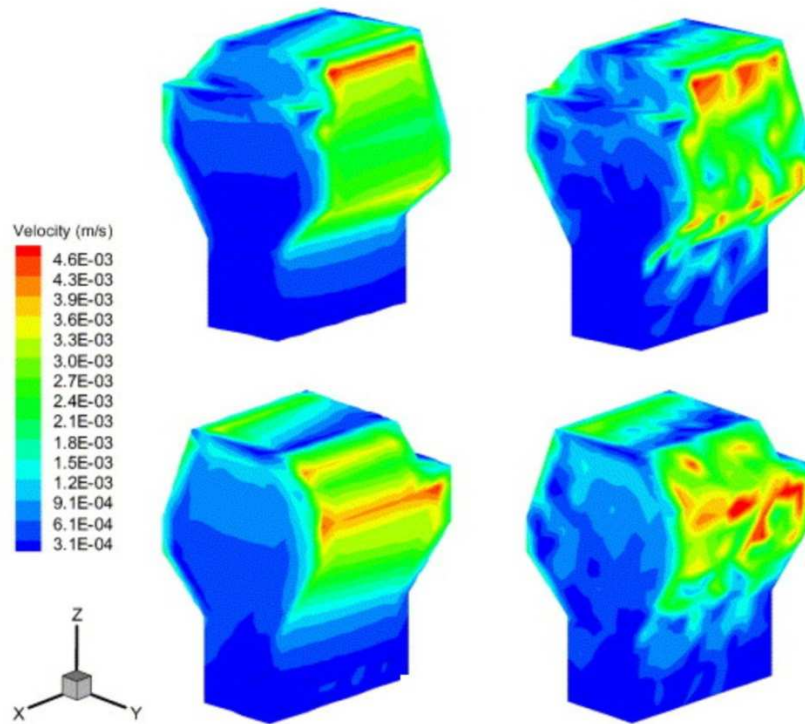

Figure 17 Inverse boundary element method [27]

1.4 EVALUATION OF THE CURRENT STATUS

It follows from above, that the baseline for determining the acoustic parameters of the drive unit, it is the determination of vibration of engine surface by which it can be further determined the acoustic pressure at a certain point in the area around the drive unit. Values of velocity at nodal points of finite element 3D model can be obtained from the results of simulations using the MBS system.

There are the methods in the field of vibration and noise, which enable to measure and locate their sources at a high level in terms of accuracy. These methods enable to verify the computational models or eventually suggest their modifications.

It should be realized that mentioned facts can be accurately applied to simple objects and structures. The combustion engine excluding substructures and their properties, which entering in to the MBS analysis also includes other elements that have a considerable effect on the vibration and associated noise.

The results of vibration of virtual engine surface are values that do not involve, for example, coolant, lubricating oil, effect of spreading of acoustic wave and their reflection inside the engine. Therefore, the deployment of computational methods for determining the emitted noise is technically possible, but the real engine will have different values of the studied parameters. Therefore, the values calculated in this way could be taken only as qualitative values, about which it is only possible to say that this version is better or worse and to determine the approximate difference. Comparing the accurate calculated values is from this perspective still the future.

As the acoustic pressure is directly dependent on the size of the velocity of engine surface vibration, it is faster and smarter way to determine this value as evaluating value. Comparison of the values for the different variants also gives only qualitative information and with a certain amount of uncertainty provides information about what is the difference between them.

By using computational methods based on FEM or IBEM, it is today possible to calculate the values of acoustic pressure emitted into the environment, on the base of the velocity of surface vibration. However, time-consuming of these methods is still relatively large and therefore their use in deciding on the design options at level of parts (block, power and bath) extends the time required for the development of the drive unit.

Also in this field there is fast and intense development and what it is now difficult or unrealistic it may be a common practice in a few years. The process of calculating the noise and vibration tends to that already in the development, it would be possible to hear from a computer what sound will affect the passenger in a car or what will hear a man standing on the street when a car goes around it. Estimation when this happens is pure lottery or shamanism.

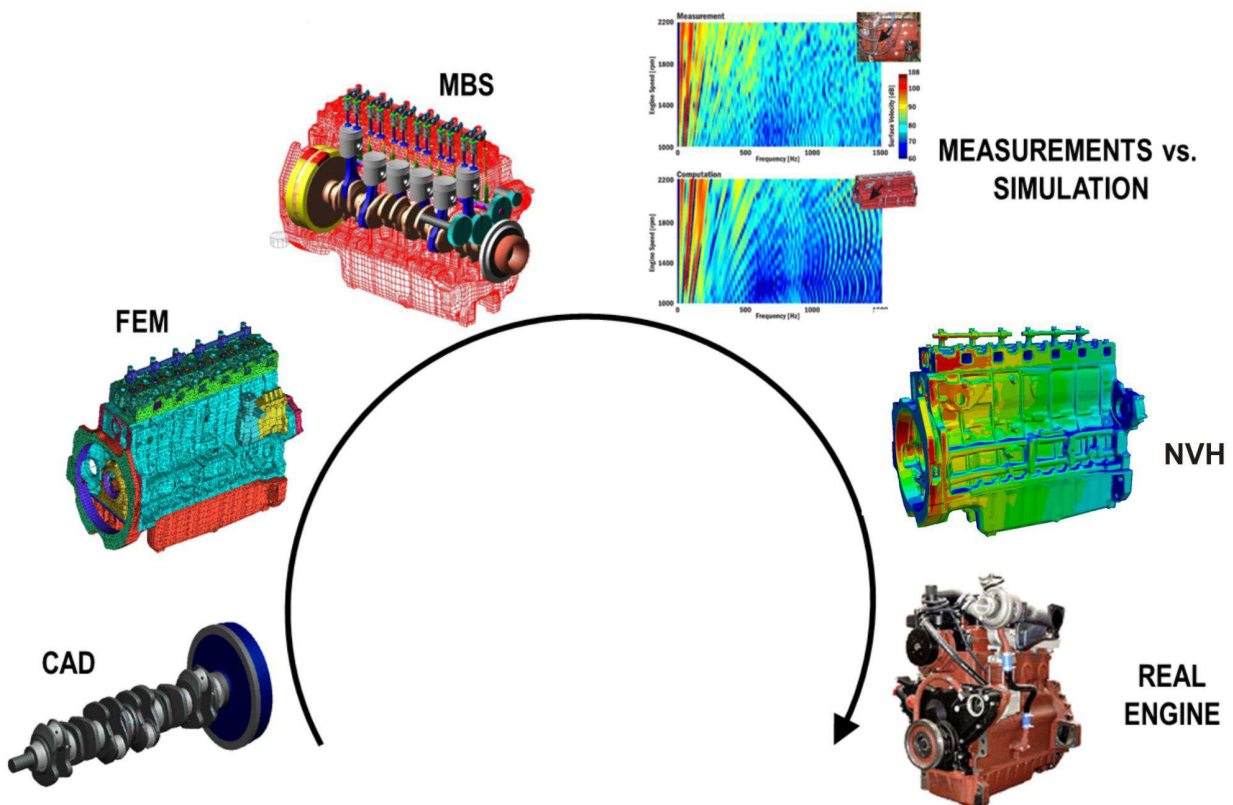

Figure 18 Development phase of virtual engine



2 AIMS OF THE THESIS

This dissertation thesis will focus on processing and visualization of the results obtained by using the virtual model. Input parameters are finite element mesh of engine and coordinated components of velocity (shift) at its nodal points.

Another aim is to propose a method how to evaluate various engineering designs and modifications in the area of the impact on vibration and thus the corresponding noise. The method will be fairly quickly and accurately compare the individual alternatives. By this method, it will be also possible to determine which variant is better or where it should come to edit.

From the last section follows, that it is preferable and more effective, as an evaluation criterion to choose the velocity of surface vibration. Therefore, in this work this criterion will be used and comparison will be on the basis of the speeds calculated on the normal components to the surface.

In order to verify the proposed method, it is necessary to take measurements. Measurements will be performed on basic models by using the contact and contactless sensors of velocity. One of the goals is a creation of a program that will process the measurement results and enable to view them by postprocessor and compare them with measurements.

Input data and computational part are implemented in Matlab program, or in a free program Scilab. Results will be presented also by the open-source postprocessor ParaView. This solution provides the ability easily develop and modify by anyone.

Another section of this thesis describes the individual steps just like they are carried out and as a logically follow. The final section includes samples of using the proposed method of evaluation of vibration respectively noise.

3 ELECTRODYNAMIC VIBRATION EXCITER

As mentioned above, to verify the model and the chosen procedure, but also to obtain input parameters into the computational model it is necessary to take measurements. For fine-tuning, it will be the measurement at first realized on a single experimental object and then to the real parts. In the experiment, it is advisable to excite the structure. From the possible ways of excitation, it was chosen vibration exciter, as the most flexible. This chapter will describe the design of the vibration exciter, the experimental finding its parameters and control software.

3.1 PRINCIPLE AND DIVISION OF VIBRATION EXCITER

One of the most common vibration exciter is an electromagnetic vibrator. It works on a similar principle as a speaker. In the center, it is usually placed permanent neodymium magnet (exceptionally, the permanent magnet is replaced by coil) around which is voice coil, through which is transmitted the alternating current. In the coil is induced alternating magnetic field, which makes it move. Force applied to the coil is then transmitted to the measured object. [17]

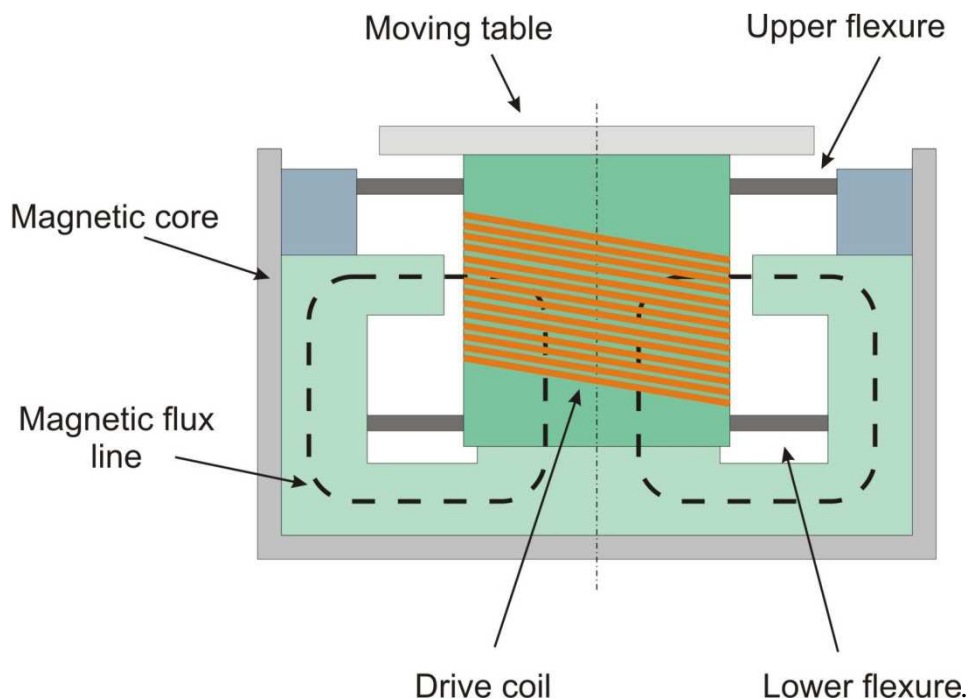

Figure 19 Scheme of electrodynamic exciter [17]

In this case, the frequency and amplitude are controlled independently, what gives more flexibility to control. Whereas, in the area of the resonance, also little power cause large deformation, it is not possible directly determine the strength from the measurement of current and voltage. Exciter power is determined by the sensor of force which is located between the rod of exciter and measured object. [17]

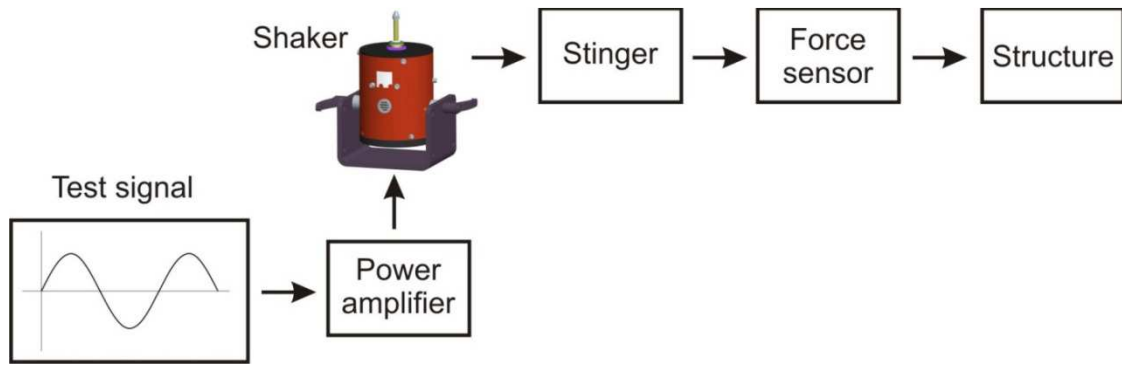

Figure 20 Parts of the electrodynamic exciter [17]

It is possible to say that the larger vibration exciter is the more force generate but to detriment of lowering the maximum frequency. Effective excitation is possible only in frequencies below the natural frequency of the coil and the table of exciter drive. Above this frequency, it is still possible to excite the system, but it is a natural limit of vibration exciter. [17]

Another type is electrohydraulic vibration exciter which allows the measurement of structures with a larger static load. These exciters are larger and technically more complex than electrodynamic exciter, and they are not used for testing of internal combustion engines. [17]

There is a one more type used for engine testing, and it is the mechanical exciter. It works on the principle of rotation of eccentrically located mass. It is capable of generating a prescribed power of certain frequencies, but its control is less flexible. Also, the effect is relatively small at low revolutions. It is a type suitable for such long-term tests, when engine revolutions of exciter are set up, and testing can easily run for several hours. [17]

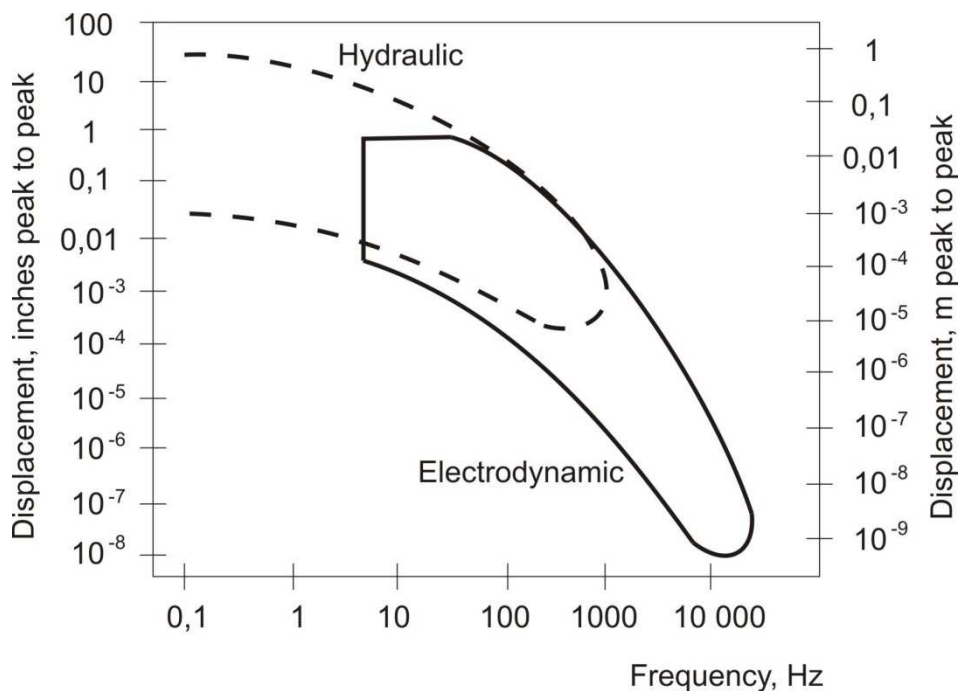

Figure 21 Coverage area electrodynamic and hydraulic exciter [17]

3.2 DESIGN OF VIBRATION EXCITER

The main parameters in the choice of the vibration exciter are force, frequency range and maximum stroke. These parameters depend on that for which application will be exciter used. Figure 22 shows what the recommended parameters for individual cases are.



Figure 22 Exciter parameters according to application [19]

In the focus of the institute and the scope of this study, it was suggested that exciter should have parameters given in Table 2.

Tab. 2 Design parameters of exciter

Parameter	Value
Force	58 – 133 [N]
Peak – Peak	18 – 36 [mm]
Max. frequency	4 000 – 6 000 [Hz]
Weight	6 – 17 [kg]

Based on this specified parameters it was necessary to choose the drive. There were two alternatives available for choice. The first one was to design the drive individually, and the second one was to find a suitable solution from other applications. Due to the risk of improper design and manufacturing errors it was chosen the second alternative, thus the use of certified industrial solutions.

It was selected the drive with a voice coil. It is the linear drive, in which is the stator neodymium permanent magnet and the moving it is made by coil connected to the source. The parameters of the selected drive are shown in Table 3. [20]



Tab. 3 Parameters of voice coil

Parameter	Unit	Value
Stroke	[mm]	35
Force constant	[-]	19,6
Voltage constant	[V/m/s]	19,6
Nominal force (coil 100 °C)	[N]	64,68
Nominal force (coil 155 °C)	[N]	84,28
Max. force	[N]	252,8
Electrical resistance	[Ohm]	2,9
Inductance	[mH]	6,61
Recommended voltage circuit	[VDC]	48
Nominal current (coil 100 °C)	[A]	3,3
Nominal current (coil 155 °C)	[A]	4,3
Max. current	[A]	9,9
Inner air gap	[mm]	0,65
Max. power	[W]	284,2
Max. coil temperature	[°C]	155
Coil weight	[g]	757,6
Weight of magnetic core	[g]	1 750

As it is shown in Figure 20, electrodynamic exciter is driven by amplitude amplifier, which is either capable of self-generated signal, or is it necessary to bring the signal into it and it subsequently will amplify. Within the greater flexibility, it was decided that the source of the signal will be specially created software that will generate a signal through the PC sound card. From there, the signal will go to an amplifier and then to the exciter.

Manufacturer of the voice coil provides the basic indicative parameters of amplifier in Table 3. Due to the fact that the design and manufacture of the amplifier is a specialized activity, it was decided to leave this part for the specialized company. In the Figure 23, is already a completed amplitude amplifier made by the voice coil manufacturer's recommendations.



Figure 23 Amplitude amplifier

The basis, in the engineering design of the vibration exciter, are available information about industrially produced exciters. In order to use the driver as flexible as possible, method of mounting of the cover must allow tilting about a horizontal axis to both sides of an angle greater than 180° . The mount of the frame is provided with holes for fastening bolts with an eye in order to hang the exciter on flexible lines or firmly mount to the ground.

The main requirement is to ensure the position of the coil closest to the center of its stroke in any position of exciter. Also, that the coil will remain in coaxial relation to a permanent magnet, so there are not friction losses, which might tend to damage the drive. Of course, there should be the possibility of easy assembly and disassembly.

Axisymmetric of the coil was assured by the 3 guide rods and the central cross. In order to eliminate friction, it was used a special plastic. Backing the position in the middle of the stroke was carried out by a spring, which was fitted on the oscillating rod through the holder, which was supported against axial movement by the pin. On the upper lid was placed the second holder. The whole engineering solution of the first design is shown in Figure Axisymmetric of the coil was assured by the 3 guide rods and the central cross. In order to eliminate friction, it was used a special plastic. Backing the position in the middle of the stroke was carried out by a spring, which was fitted on the oscillating rod through the holder, which was supported against axial movement by the pin. On the upper lid was placed the second holder. The whole engineering solution of the first design is shown in Figure 24.

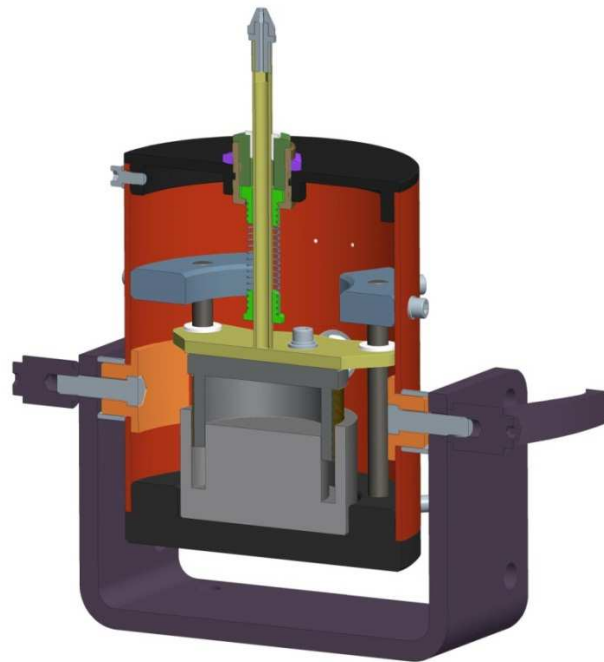

Figure 24 First design of exciter

After assembly the first design and start testing, it was found that handles mounting which enables rotation, was after several attempts unable to hold the weight of cover with drive unit. This was due to rotation of support in inside the cover. Also, mounting of the coil, after a few minutes of operation and especially after loading at low frequencies but on high amplitude, stopped fulfil its purpose and the coil fell and touched the permanent magnet.

For ensuring of axisymmetric and center position of voice coil, it was designed special spring (Fig. 25), where the axial stiffness in comparison with the radial is much smaller. Due to its shape it provides axisymmetric also in the deformation.

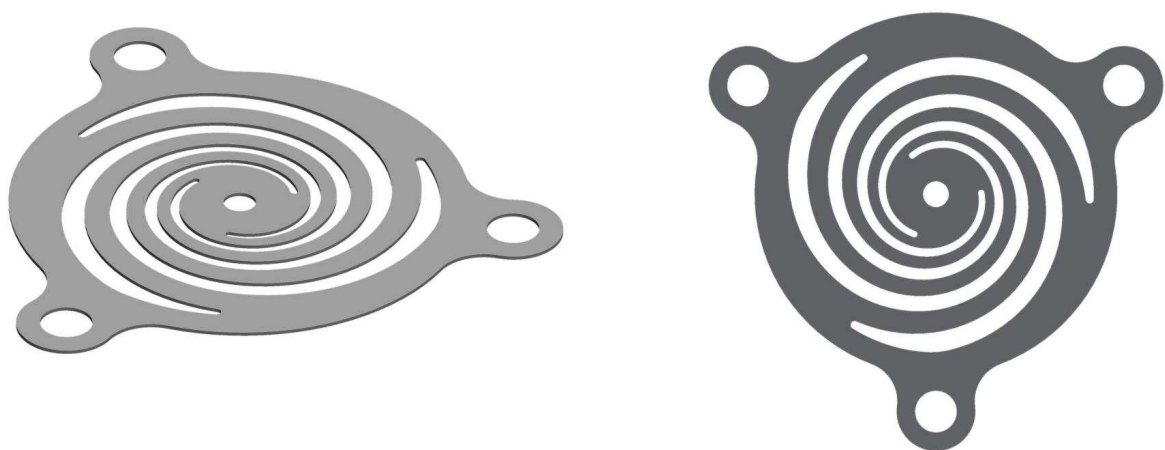

Figure 25 Special spring of exciter



This solution allows for easy adjustment of ensuring the center position. First by using FEM it has been designed shape and thickness of spring. The design was based on the weight of moving parts, maximum stroke and expected maximum power in the extreme positions (Fig. 26). According the FEM results, several prototypes were produced and then during the measurement it was selected the most appropriate one.

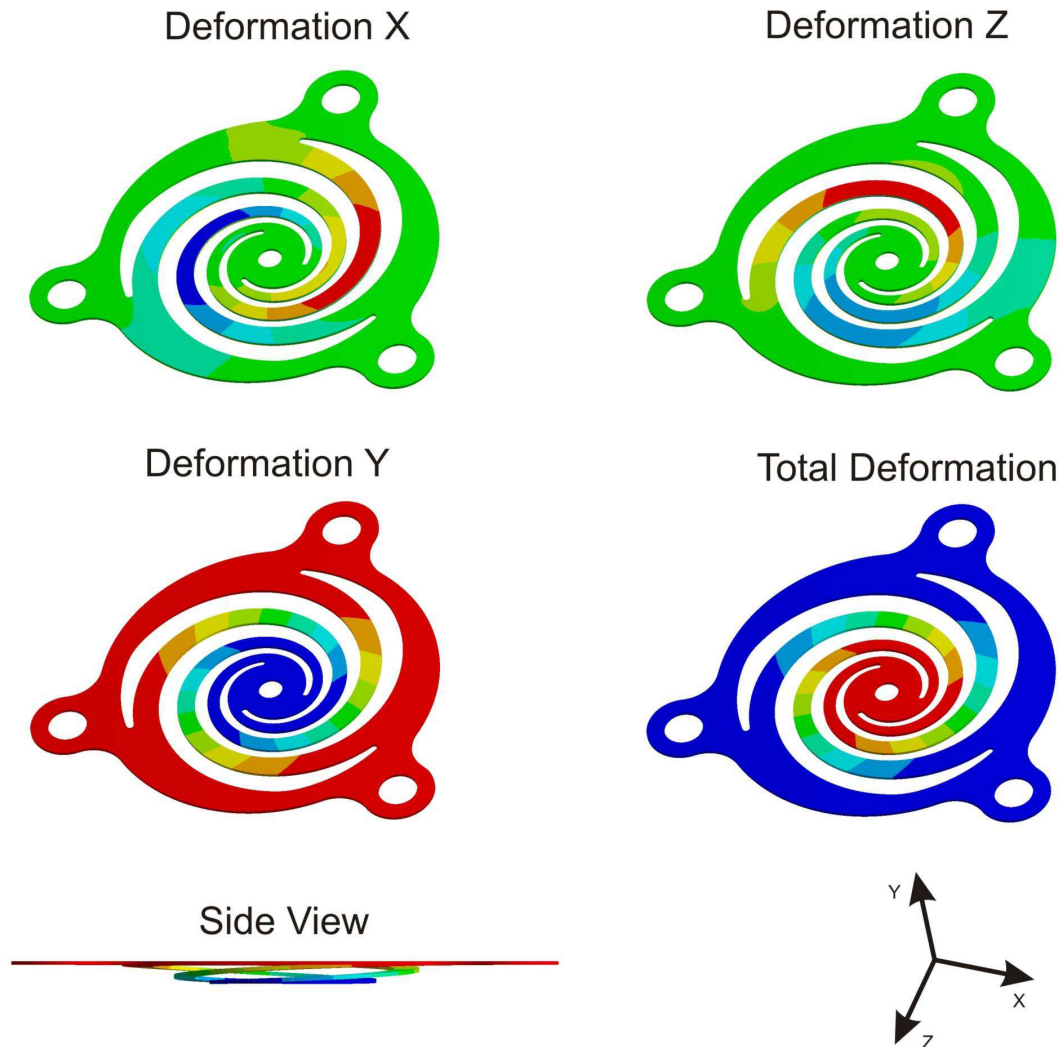

Figure 26 Spring deformation

In the second design, it was also ensured the fixation in a certain position, and it was prevented rotation of the cover of exciter. The solution was based on rotation of support by 90° , what caused contact with the lower lid, and thus assurance against rotation.

In Figure 27, there is the modified design of exciter with an adjusted way of support of tilting of cover and with special axial spring.

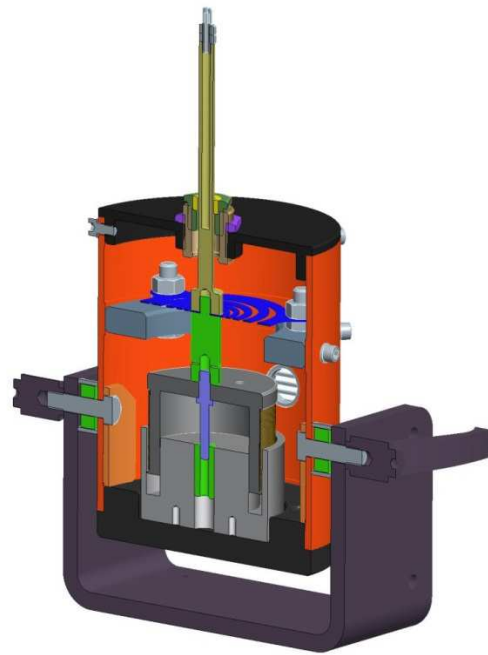

Figure 27 Final design of exciter

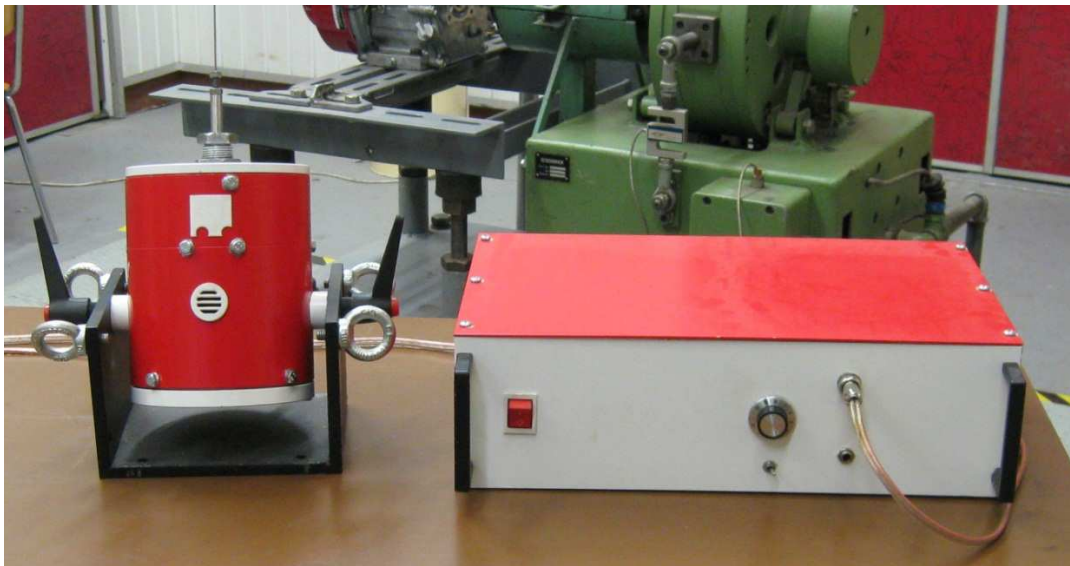

Figure 28 Electrodynamic exciter and amplitude amplifier

3.3 EXPERIMENTAL VERIFICATION OF PARAMETERS AND PROPERTIES

After the essential structural adjustments and assembling of vibration exciter, it was necessary to experimentally verify the whole system. The aim was to find out the real parameters of the vibration exciter, in order to determine where the boundaries are and for what applications are actually appropriate. It also brings information which enable to prevent overloading and possible destruction.

The measurements were performed in the laboratories of the institute with available technology. At first, it was detected what parameters has signal generated from sound card and parameters of amplitude amplifier. For the measuring, it was used diagnostic device FSA 750 NRS from Bosch company, notebook Lenovo R61, signal in format *.wav, software Windows Media Player and multimeter.

The diagnostic device is used to diagnose cars. Among other functionalities, the device includes a signal generator and oscilloscope.



Figure 29 Bosch diagnostic unit FSA 750 NRS [21]

The first measurement was focused on identification of parameters of the signal generated by sound card in the laptop. The measurements were carried out at more frequencies. These measurements showed that the lower limit of the sound card, when the signal still has ideal waveform, is 10 Hz. Below this value sound card ceased to generate tension. Another important finding was that the ideal form of a sinusoidal signal it is not possible to obtain, when the sound card settings is on maximum. This finding was also tested on another PC and another player. Volume higher than 76% leads to cutting peaks. The maximum voltage from the sound card was measured 1,19 V. The measurement was carried out with such a sound card settings, that the maximum effective value of the signal was about 0,7 V, and thus maximum voltage 1V. This signal was input into the amplifier, where the output was measured by using an oscilloscope in diagnostic equipment.

The measurement of the amplifier was carried out such that on the input into the amplitude amplifier it was supplied alternating current of various frequencies and amplitudes, identically



as by measured of laptop. On the oscilloscope, it was monitored how waveform of the signal is changing and also what the amplification is. Due to the fact, that the designed amplitude amplifier from engineering principle cannot amplify the rectangular signal, the measurements were made only on the sinusoidal signal. It is important to note that this type of signal it is most used in applications for which the exciter has been designed. The amplifier has been designed in this way from a reason that the PC sound card is unable to generate ideal rectangular signal, which using has been already in the design assessed as insignificant.

Results for notebook and diagnostic equipment it can be seen in Table 4

Tab. 4 Measuring the amplification

Generator	Input voltage	Frequency	Position of control wheel									
			1	2	3	4	5	6	7	8	9	10
BOSCH	0,717	30Hz	0,95	2,45	5,02	7,15	9,12	10,96	13,18	16,32	20,11	20,26
	0,717	300Hz	0,18	2,41	5,33	7,52	9,41	11,35	13,85	17,17	21,12	21,41
	0,720	600Hz	0,21	2,49	5,44	7,53	9,60	11,38	13,90	17,29	21,29	21,44
	0,722	900Hz	0,15	2,76	5,39	7,65	9,68	11,73	14,11	17,15	21,37	21,52
NOTEBOOK	0,710	30Hz	0,20	2,56	5,31	7,32	9,12	10,91	13,32	16,35	19,83	20,09
	0,715	300Hz	0,14	2,81	5,66	7,80	9,74	11,73	14,27	17,69	21,71	21,88
	0,717	600Hz	0,41	2,91	5,68	7,82	9,79	11,64	14,47	17,69	21,88	22,05
	0,716	900Hz	0,13	2,93	5,76	7,75	10,15	11,91	14,34	18,03	22,14	22,31

Results for notebook and diagnostic equipment it can be seen in Fig. 30

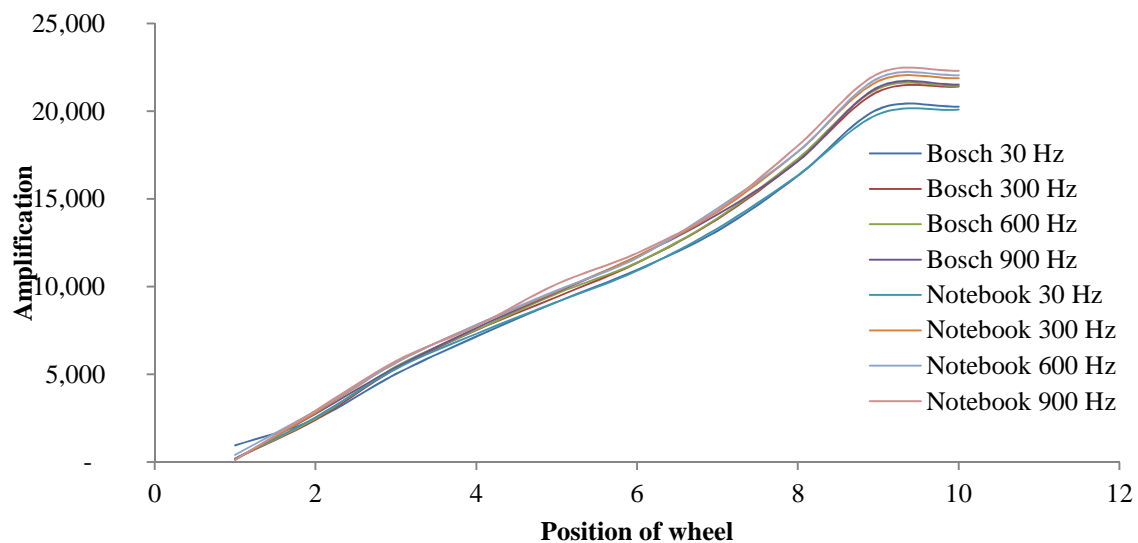

Figure 30 Graph of amplification for wheel position and frequency

The use of diagnostic equipment has a disadvantage in significant inaccuracies in the measurement of electrical variables. However, the objective of the measurement was not accurate measuring of values, but only finding the limits and characteristics of individual systems. Moreover, as mentioned above, measure electrical parameters and consequently on their basis expect the force that develops driver is not correct.

In the next measurement was intended to determine the waveform of acceleration depending on the position of the control potentiometer and frequency signals. In this measurement, it was used as a source the notebook. At the end of the rod of vibration exciter, it was mounted



the sensor of acceleration. Vibration exciter was oriented such that its axis was horizontal. This arrangement it was chosen to avoid the impact of weight of sensor on the acceleration.

The resulting measured waveform it can be seen in the Fig. 31

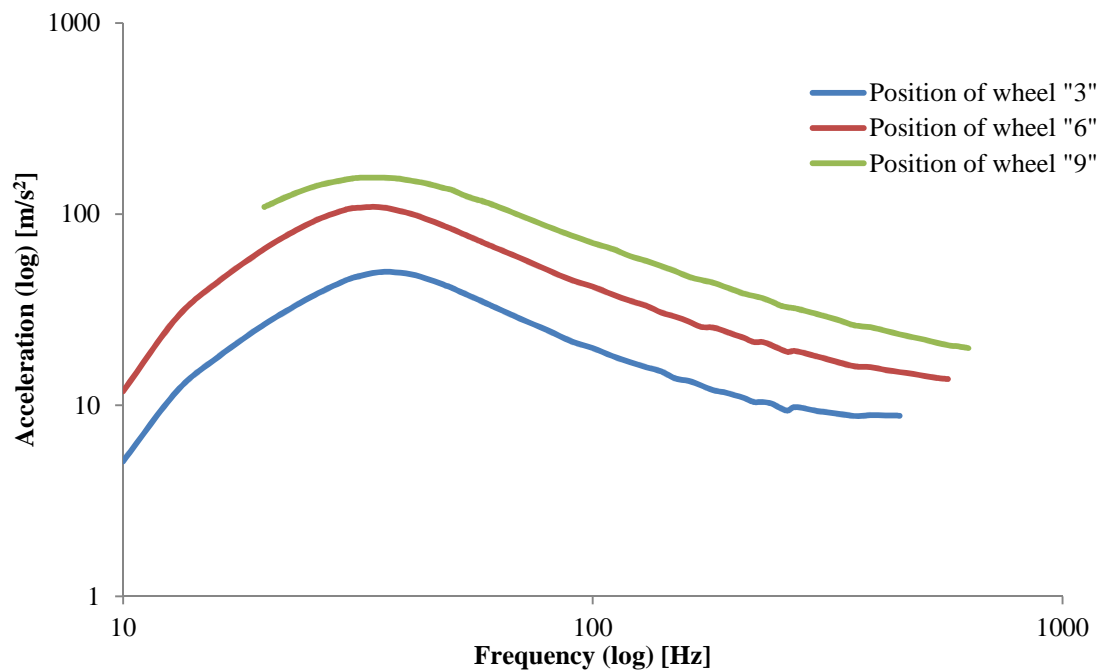

Figure 31 Graph acceleration for exciter

This waveform is characteristic for electrodynamic vibration exciter, where through the coil passes current with constant amplitude. The whole process has three distinctive areas. Low and medium frequencies correspond to the flexibility of moving parts of exciter and its flexible position. In the range of high frequency, there are expressed axial resonances of moving parts of exciter. These areas determine the maximum usable frequency of the vibration exciter. The whole process of characteristics can be seen in Fig. 32. [22]

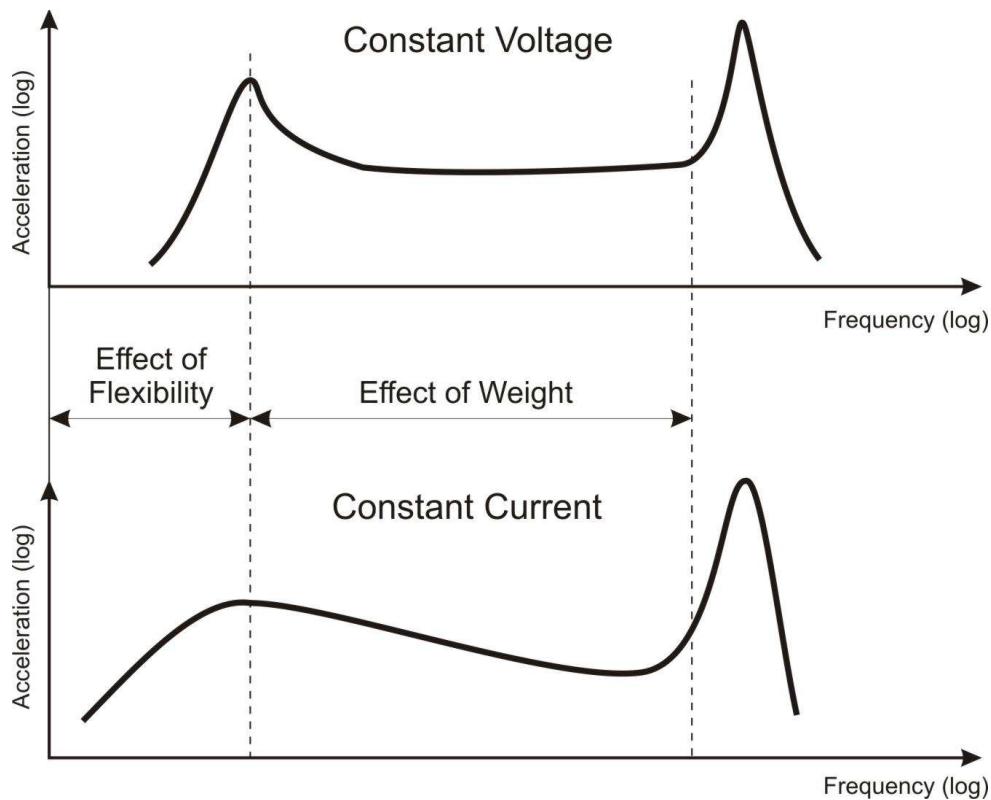

Figure 32 Ideal graph acceleration for exciter [22]

The same three areas have the characteristics of exciter, where the coil is connected to a source with constant amplitude voltage. In the measurement, it is usually a requirement for constant waveform of displacement of oscillations. As mentioned above, this is especially difficult to set up when passing through the resonance frequency and due to the eigen characteristics of the amplification. Therefore, it is usually in to the system of amplifier even adds feedback, which processes the data measured directly on the measured object. This feedback is also sometimes called a compressor. It must be fast enough so it could respond to a few muted oscillations in the resonance [22]

Whereas the exciter is currently used mainly for experimental modal analysis, it was decided that this compressor it is not necessary to carry out by feedback. However, into the generator of signal it was implemented the compressor, which removes the measured properties of the moving parts of exciter.

When using a powerful exciter, by which it will be tested an object with a low weight, it can cause a damage in using low frequency. Therefore, it is recommended before measuring either to carry out a simple calculation of the maximum parameters or the second option is to have a look at already drawn graph in the instructions for better orientation.

In order to prevent damage, it has to be the maximum displacement in measurement less than it is physically possible for the exciter. For determination of the displacement at known acceleration and known frequency, it is valid [23]:



$$d = 496,82 \frac{g}{f^2}, \quad (34)$$

where g is the number of how many times it is the used acceleration higher (smaller) than the gravitational constant (9,81 m/s²), f is the frequency of oscillation and d is the amplitude.

From the known weight, the moving parts and the estimated load of exciter and from the known frequency it remains only to check whether the available exciter has adequate parameters. The dependence of acceleration on a moving weight for the designed driver it can be seen on Fig. 33.

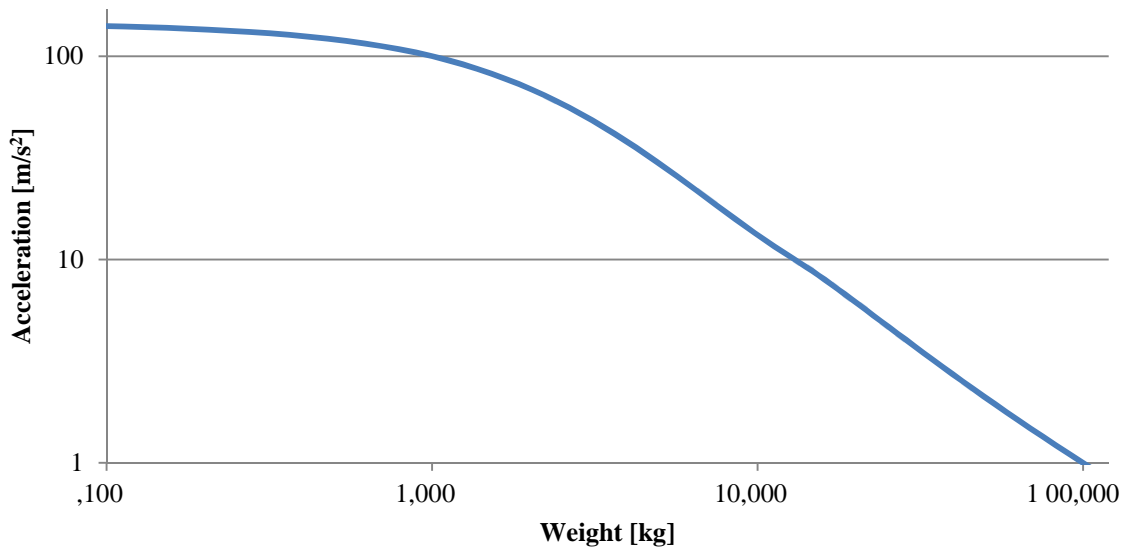

Figure 33 Graph dependent acceleration on weight

The resulting parameters of the designed and engineered vibration exciter it can be seen in Table 5.

Tab. 5 Exciter parameter

Parameter	Value
Force	100 [N]
Peak – Peak	25 [mm]
Max. frequency	1 500 [Hz]
Weight	16 [kg]

In comparison with Table 2, it can be concluded that stroke, max power and max acceleration are satisfying the requirements. However, the exciter is currently able to excite only the frequency to 1500 Hz and only at relatively small weights. This condition it is caused by the undersized amplitude amplifier, when electric power of the coil it is used only on 40%. In the future, it would be appropriate to adjust the amplitude amplifier, as the current state still



provides sufficient scope to improve the parameters. It is possible with considerable certainty to expect that after the adjusting of the amplifier will exciter meet all the parameters that have been specified in the design.

3.4 THE CONTROL SOFTWARE

As mentioned above, the primary source of signals, for which it is the system designed, is the PC or laptop sound card. In order to generate the signal in real time, it was created a specific program.

The program was written by using Matlab and converted, so it can run on any PC with Microsoft Windows operating system. Program, in addition to generating the signal, allows a saving in to file *.wav. This type of file can be run in different programs and operating systems.

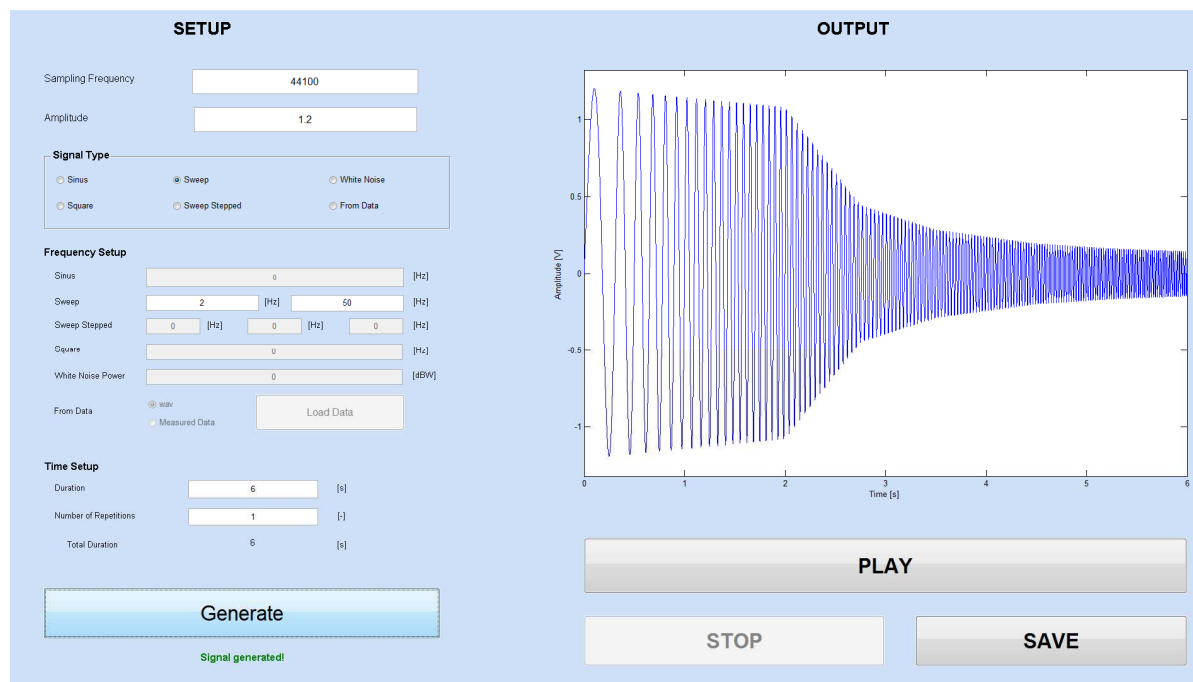

Figure 34 Interface of signal generator

The program also allows to give as the input any *.txt or *.dat file with a record of the measurements and then to play or create an output file.

The solution designed in this way has several advantages. One of the most important is that the generator is not bound to a specific PC by the license. It allows creating a database of tested signals with different characteristics. Because the input to the amplifier is the output from the sound card and thus 3,5 mm termination, it is also possible running by using smart phones, what increases flexibility and mobility of device.



In the program, it is implemented also the compressor, whose parameters were obtained by measurement as it is described in the previous subsection. In case of changes in amplitude amplifier or in design of exciter, it is easily possible to edit compressor by using *.dat file, that is loaded each time when the program starts. The form of the correction compressor of amplitude depending on the frequency it can be seen in the Figure 35.

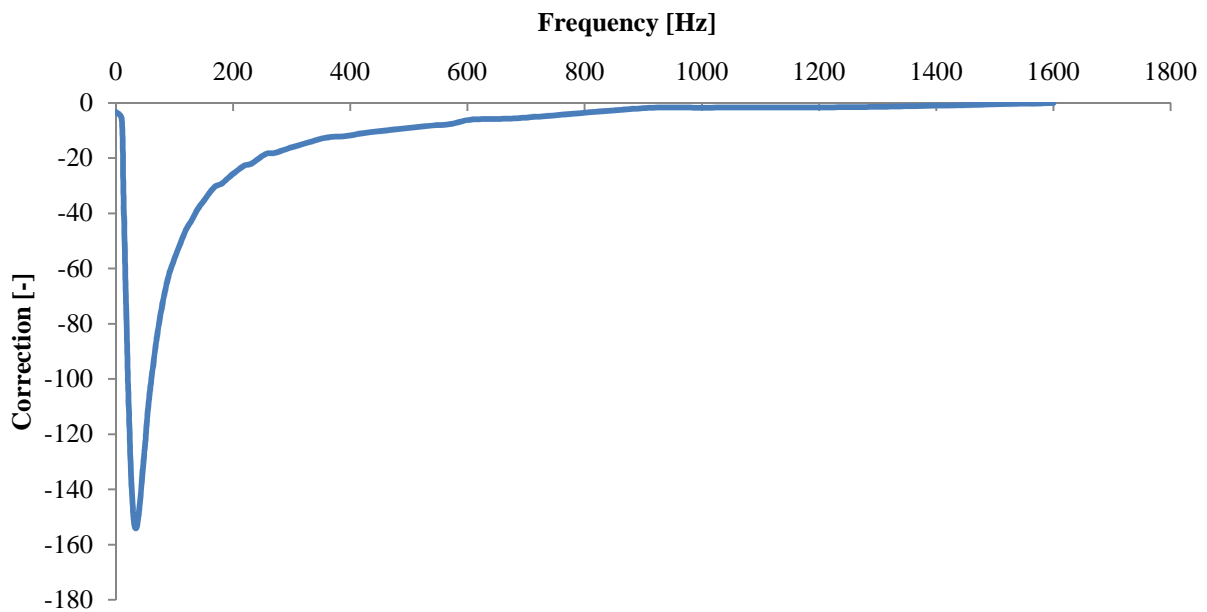

Figure 35 Software compressor



4 EXPERIMENTAL MODAL ANALYSIS

This chapter will discuss the experimental modal analysis, which is one of the methods of measurement and detection of dynamic properties of structures or systems. In the first part of this section, there is the basic theoretical analysis of experimental modal analysis (EMA). The following section contains a method of data processing method from measuring and determining the mathematical description of dynamic properties of the measured object. The final section deals with software for processing and evaluating of measurement results.

4.1 PRINCIPLE OF THE METHOD

The reasons for the realization of modal tests may be several. The main reasons may include [17]

- Identification of the modal parameters (natural frequencies, eigen forms or damping)
- Comparison of the experimental data to the data obtained by calculating
- Adjustment of the computational model according to reality
- Correlation of the experimental data and the computational model
- Creating the model, which enable to predict the impact of structural changes on the vibration
- Use the results to determine the excitation forces of the system

The analyzed system can be described by using three different types of models, which are determined by the system matrices:

The Physical model:

- Mass matrix \mathbf{M}
- Stiffness matrix \mathbf{K}
- Viscous damping matrix \mathbf{B} or hysteresis damping matrix \mathbf{H}

The Modal model:

- Spectral Matrix
- Modal matrix

The Response model:

- Frequency response function matrix \mathbf{H}

In the theoretical vibrational analysis, it is progressing towards from the physical model to the response model. In the EMA there it is the opposite way. Frequency response function (FRF), which forms the basis of the model it is expressed as follows [17]:

$$H = \frac{\text{Output}}{\text{Input}} = \frac{\text{Motion}}{\text{Force}} = \frac{\text{Response}}{\text{Excitation}}$$

The principle of modal testing is that the measured structure it is excited by the strength, which waveform it is measured and simultaneously it is measured waveform of the vibration response of the system on this force. For measuring of the response, it is usually used the



sensor of acceleration. If this measurement it is made on of a sufficient number of points, the result is the response model.

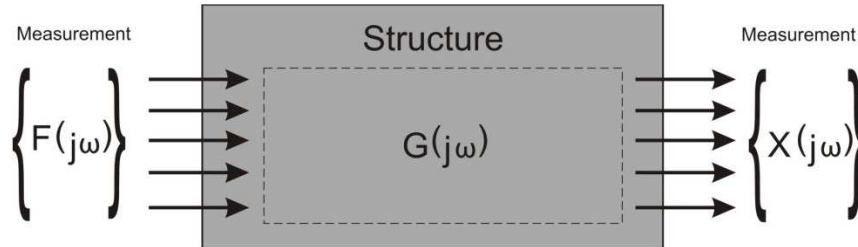

Figure 36 Principe of modal testing [24]

The exact definition of a matrix element FRF is [17]:

$$a_{jk}(\omega) = \frac{x_j}{F_k} = \sum_{r=1}^N \frac{\Phi_j^r \Phi_k^r}{\lambda_r^2 - \omega^2} \quad (35)$$

where λ is a value of r -th mode, Φ is the j -th element of the r -th vector of eigen forms (Φ), i.e. the relative displacement in the j -th point of oscillation on the r -th form and N is the number of modes.

If we use the relation 35, it is possible to show that an appropriate set of measured receptances must contain only one row or a one column of mobility matrix. This means that either the system is excited at one point and responses are measured in all other points, or the response is measured at one point, and the system is excited in all other points. The first option it is used for excitation by exciter and the second in using a shock hammer [17].

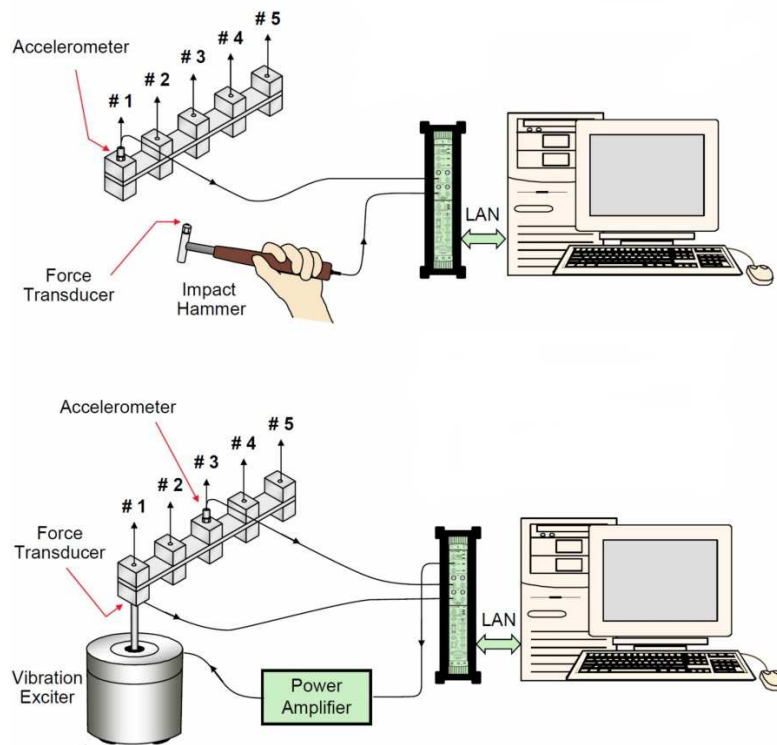

Figure. 37 Difference between measurement with hammer and exciter [17]

In practice, you can get 3 types of FRF, which depend on what the variable is measured: [17]

Tab. 6 Variable types of FRF

Frequency Response Function		
Response parameter r	Standart $\frac{r}{F}$	Inversion $\frac{F}{r}$
Displacement	Receptance Admittance Dynamic compliance Dynamix flexibility $\alpha(\omega)$	Dynamic stiffness
Velocity	Mobility $Y(\omega)$	Mechanical impedance
Acceleration	Inertance Accelerance $A(\omega)$	Apparent mass

For a description of the interrelations of these signals in the frequency domain, it is used the FRF H , and in the time domain, it is used the impulse response function (IRF). These are so called the descriptors of the system and are independent on the signal [17].

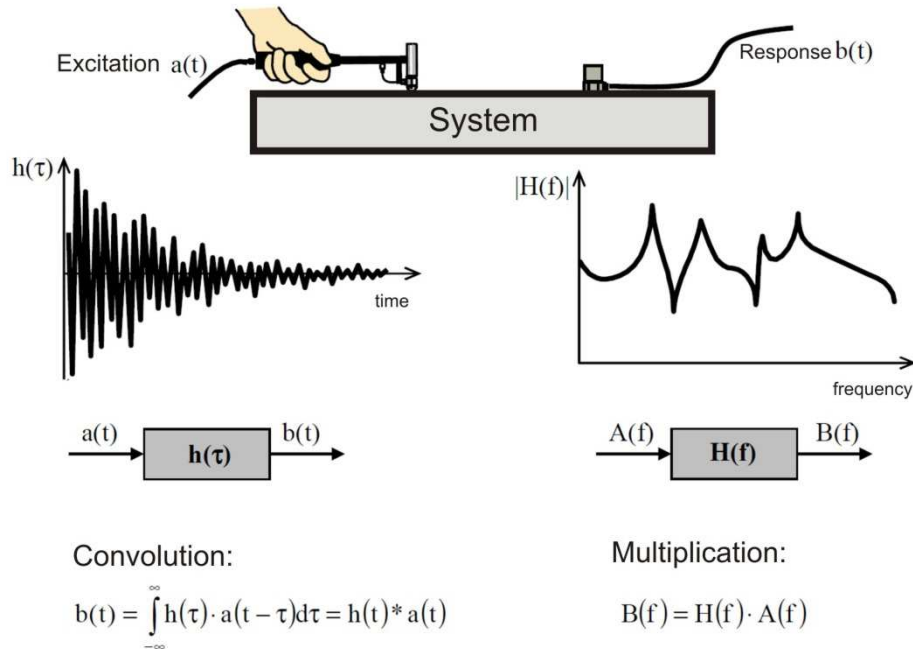

Figure 38 Frequency response function and impulse response function [24]

Aim of EMA is thus the determination of FRF, and also the frequency characteristics of the system. For better understanding of identification of parameter, it will be the method shown on mass-spring-damper system, which is easy to describe. Mass-spring-damper system consists of mass, spring and damper (see Figure 39).

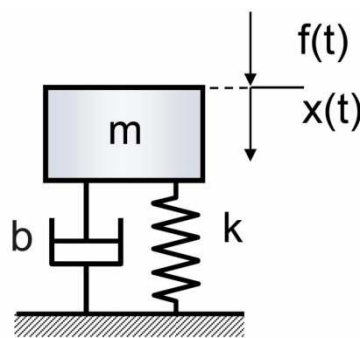

Figure. 39 Mass-spring-damper model [25]

The movement of this system is described by the equation [25]:

$$m\ddot{x}(t) + b\dot{x}(t) + kx(t) = f(t), \tag{36}$$

where m is mass, b is damping, k is stiffness and x is displacement.



Solution of this equation has the form:

$$x(t) = X e^{j\omega t} = \frac{1}{1 - \eta^2 + 2j\zeta\eta} \frac{F}{k} e^{j\omega t} = \frac{1}{k - m\omega^2 + j\omega b} F e^{j\omega t}, \quad (37)$$

where X is complex amplitude of displacement, F/k is static displacement, η is dynamic magnification factor and ζ is damping ratio.

Fraction $\frac{1}{1 - \eta^2 + 2j\zeta\eta} = H(\eta)$ is called amplification factor, or also FRF in dimensionless form. The proportion of the complex amplitude of the displacement and the excitation force is a function of receptance that is FRF but no longer dimensionless. For a system with 1° of freedom it looks as follows:

$$H(i\omega) = \frac{X(j\omega)}{F(j\omega)} = \frac{1}{k - m\omega^2 + j\omega b} = \frac{R}{j\omega - (-\delta + j\Omega)} + \frac{R^*}{j\omega - (-\delta - j\Omega)}, \quad (38)$$

where R is rezidum, Ω is natural frequency of damped oscillation, δ decay constant.

Because this is a complex function, it is not possible to represent all the information by 2D chart. The most commonly used it is displaying of the amplitude - frequency characteristics. All methods of displaying of FRF are shown in Fig. 40.

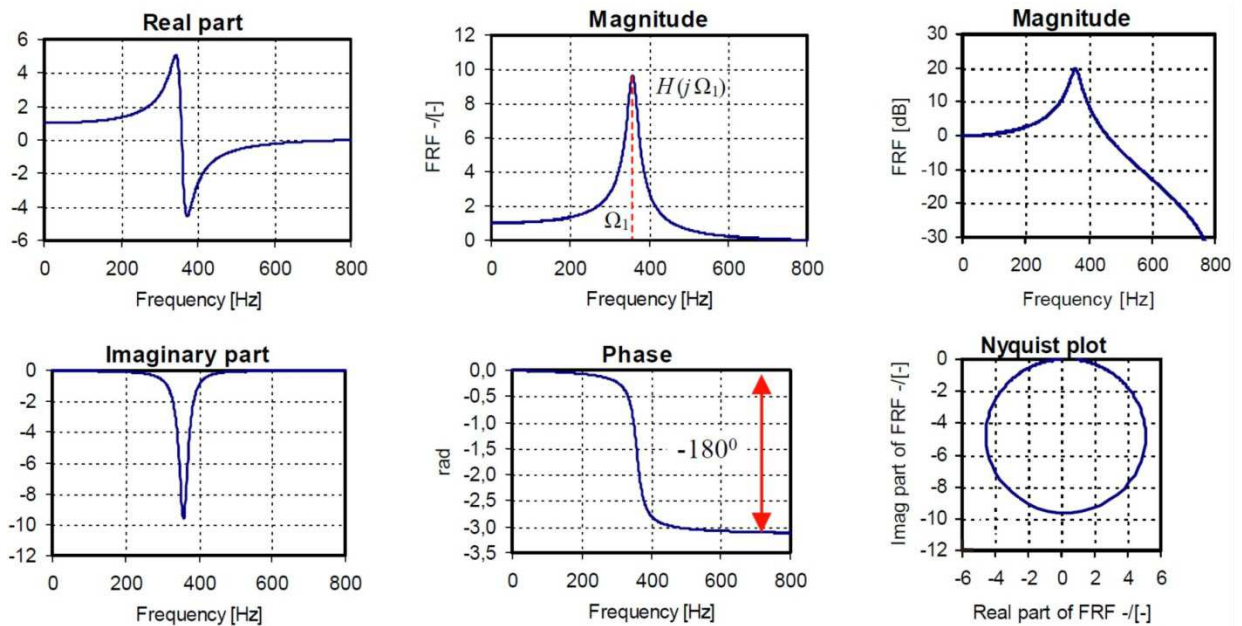

Figure 40 Display options of FRF [24]

In the amplitude characteristics, it is possible to distinguish 3 areas [17]:

- In the vicinity of resonance there is the area influenced by the damping of the system - higher damping means lower and wider peak.
- Below the resonance frequency it is mainly influenced by the stiffness of the system.
- Above the resonance frequency it is influenced by the weight of the system.



In order to obtain a description of the system, it is, in addition to FRF, used also IRF. To obtain the IRF, it is the system excited by Dirac impulse (impulse hammer) at different points of the system and the response is measured at one point. This method was not used in this work and therefore it will not be paid attention to it anymore.

As mentioned above, the main reason of EMA is to obtain the documents for mathematical description of the real system. This concept involves determining of natural frequencies and eigen forms and finding damping.

For mass-spring-damper system there is the relatively easy determination of natural frequencies and damping. Talking of eigen form in this case is irrelevant, given that the mass-spring-damper system has only one degree of freedom.

In the FRF chart, where it is visualized the dependence of amplitude on frequency, and natural frequency it is determined by the maximum value of the amplitude.

For the description of the damping, there are most commonly used two types of models. It is a viscous damping and hysteresis damping. Hysteresis damping is more precise for the forced vibration of systems with more degrees of freedom but for the free vibration is problematic. More often it is for description of the damping used viscous damping.

This value can be obtained by two ways. The first option is from the chart of dependence of real component on frequency (see Fig. 41).

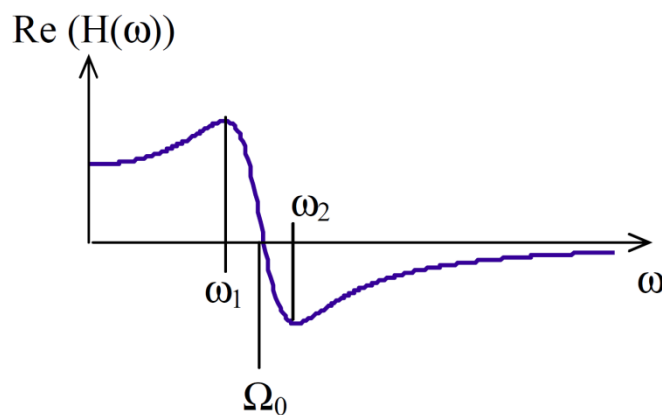

Figure 41 Plot of real part[17]

Where from the graph it is subtracted the frequency in which the waveform of real component has a maximum and a minimum. Then, by using a single relation, it is given:

$$2\zeta = \frac{\left(\frac{\omega_2}{\omega_1}\right)^2 - 1}{\left(\frac{\omega_2}{\omega_1}\right)^2 + 1}. \quad (39)$$

The second option is called half-power point method (half-power point). This method uses a waveform of dependence of amplitude on the frequency. Determination of the proportional damping is also relatively simple. In the point of natural frequency, it is found the maximum amplitude. Next it is calculated its size of half-power (i.e. formula it is divided). In this value,



it is led the parallel line to the horizontal axis, and where it crosses the graph of dependence, there the frequencies are subtracted (see Fig. 42).

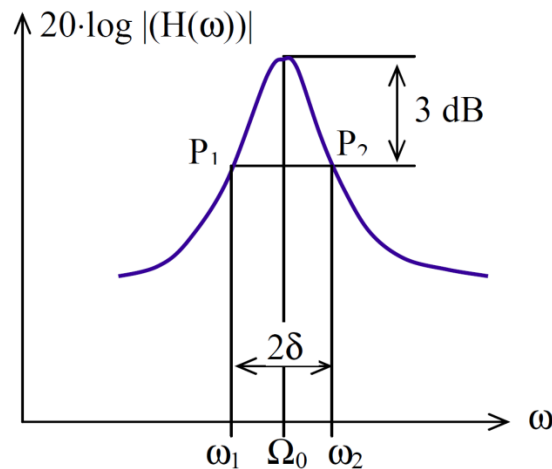

Figure 42 Half power point [17]

Damping ratio determined using:

$$\frac{\omega_2 - \omega_1}{\omega_0} = 2\zeta. \quad (40)$$

When measuring the EMA it should be well considered the way of fixation of the measured object and also the way of exciting. The method of fixation it is given primarily by purpose of measurement or limitations stemming from the operating conditions. In principle, it is possible to distinguish 3 ways of fixation:

- **Free:** (on an extremely soft springs): this is the easiest way of the fixation and it is most commonly used for the correlations of an experimental model with the computational.
- **Fixed:** measured object is firmly fixed in one or more points. The difference in comparison of an experimental model with computational can be larger, and this is due to that it is impossible to implement absolute prevent of movement. This method is suitable e.g. for turbine blades.
- **In situ:** on-site (at operating conditions) it is mainly used when are finding real parameters in the condition, where the examined object is actually present and working. It is not usually to compare computational model with experimental.

It follows from above that, as a method of excitation, it was chosen electrodynamic vibration exciter. It allows to use a relatively wide range of excitation signal, either in terms of the frequency of excitation or in terms of displacement respectively excitation power. As it follows from the theoretical analysis, the sensor of force should be as close as possible to the examined system. In Fig. 43, it is schematically shown the layout of system. [17]

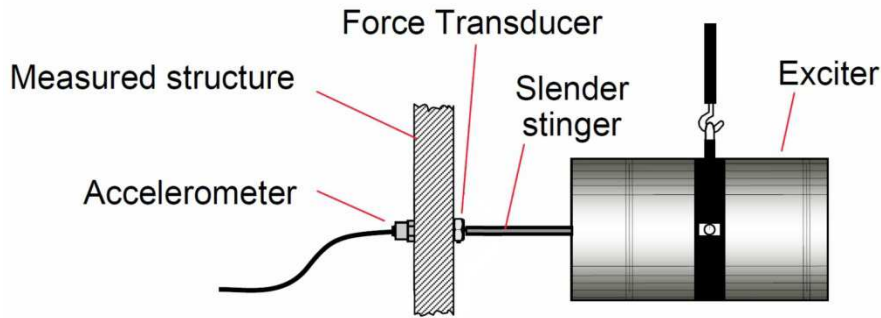

Figure 43 Scheme of system [17]

When the vibration exciter it is fixed, it necessary to ensure that excitation does not transfer into the system. Because it is not possible to measure this excitation in the input, but it will be reflected in the output signals. The formation of this excitation it is caused by that, the rod of the vibration exciter is moving in one direction (in the direction in which it is excited) and rigid in other directions. However, for complex structures there can the object excited in one direction react in a different axis but this prevents the rod stiffness in this direction. By this are arising additional reaction moments, which the sensor of force does not measure, but they input into the system. Therefore, it is between the rod of exciter and the measured object (or sensor of force) placed the excitation rod. It is usually made from spring wire, plastic or even from piano wire. The excitation rod supposed to be rigid in the direction of excitation and relatively flexible in other directions. It is also necessary to pay attention to the length of the rod in order to the input signal into the system was not affected by natural resonances of rod. [24]

Another important thing when measuring, is a way of fixing the exciter in terms of impact and transfer of reaction forces. Generally, the best arrangement is when the measured object and the vibration exciter are fixed freely. However, this requirement can not always be met. In Fig. 44, there are the possible ways of fixing the vibration exciter.

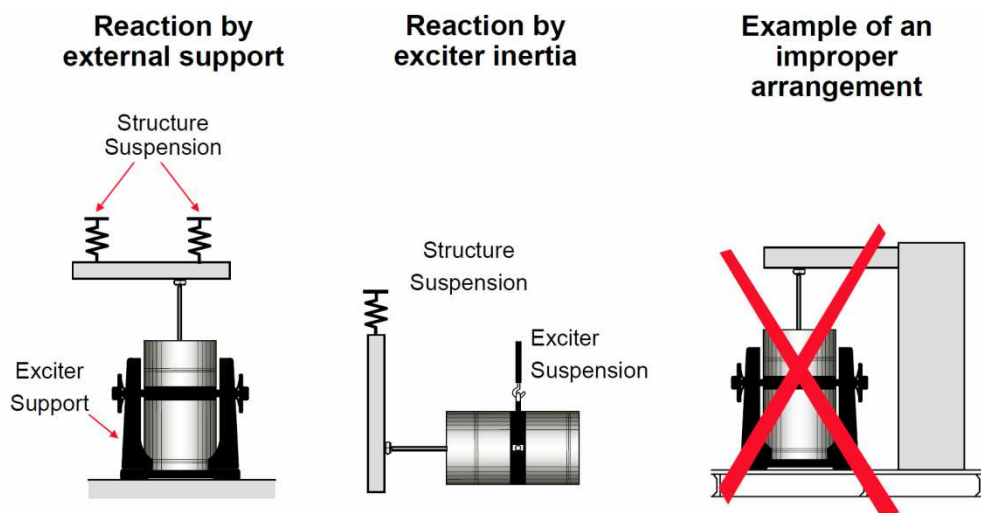

Figure 44 Possible ways of fixing the vibration exciter [17]



The issue of EMA is quite extensive, and object of this work it is not a detailed description. When measuring and evaluating, the information were obtained primarily from [17], [24], [25].

4.2 EVALUATION OF MEASUREMENT

Analysis of natural frequencies and damping is relatively easy for mass-spring-damper system. However, real cases are more complicated and complex. Therefore, it is not possible these values easily to subtract from the chart.

The first problem is that it is measured in more points. This is connected with certain complications. Despite the best efforts, it is quite likely that one or more sensors are placed close to the nodal points. In this case, the visualized waveform of FRF would be significantly distorted. Also, orientation in the maze of graphs (see Fig. 45) and determination, which peak is the right one, it is a problem. Therefore, there are the methods by which it is also possible from a large number of points accurately and quickly determine natural frequencies, damping and waveform of FRF.

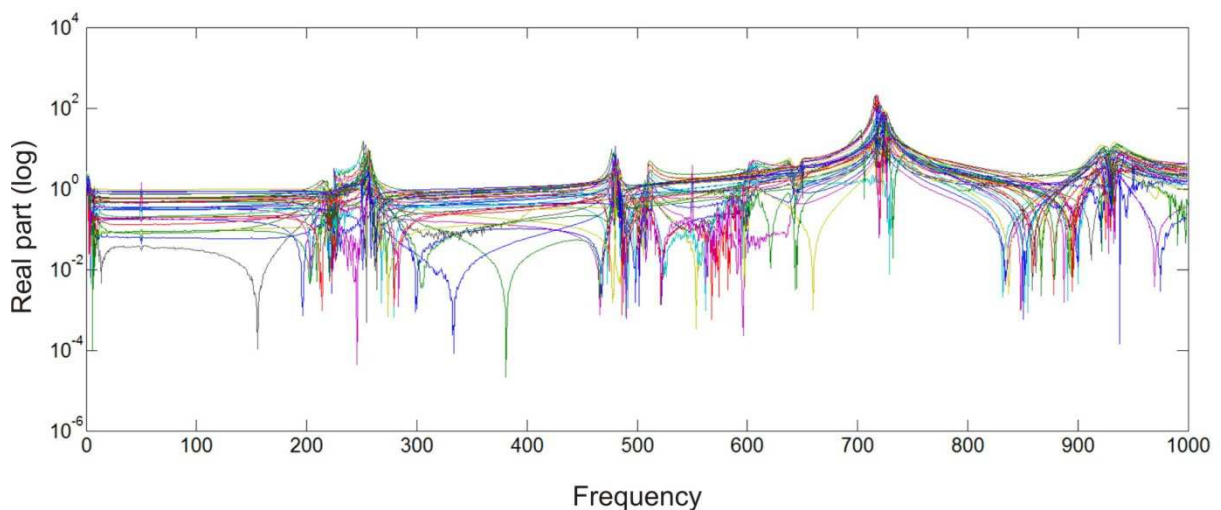

Figure. 45 FRF of measurement points

The most common include [26]:

- SUM – Summation function.
- MIF – Mode Indicator Function.
- MMIF – Multivariate MIF.
- CMIF – Complex Mode Indicator Function.

The simplest method is the Sum method. It is an addition of amplitudes to each point in individual frequencies. The main idea is that basically every point (if it is not for a certain form a nodal one) have to at its natural frequency reflect increased displacement and thus the sum of these displacements will clearly show the waveform of FRF. The accuracy of this method depends on the number of measured points, i.e. the more of individual waveforms of the FRF, the accurate result. This method is not suitable if the natural frequencies are close



together. Subsequently the effect of measurement errors can accumulate and by using of this method information of natural frequencies will be lost.

Better results can be obtained using the MIF method. Basis of this method is the proportion of the real part of FRF and amplitude. The idea of this method is relatively easy, since the real part changes a sign and crosses zero just at their natural frequency. Thus, the proportion of amplitude and real part has a minimum right in the place of its natural frequency. This method is suitable only for the one measurement, but the error caused by improper fixing of sensor significantly distorts the results.

The MMIF method is actually the MIF method used for more points (more measurements). After calculation the MIF at each measured point, it is possible to use either averaging or addition, similarly as in the SUM method. Methods MIF and MMIF are appropriate when the waveform of the real part of the FRF goes through zero. However, in practice there are often the cases when the measurement is affected by noise or other impacts and the measured real component does not have an ideal theoretical waveform.

The most accurate method for determining the natural frequencies is the CMIF method. It bases on singular value decomposition, which consists of measured data of FRF at individual points. Singular value decomposition is defined [33]:

$$[\mathbf{H}] = [\mathbf{U}][\mathbf{\Sigma}][\mathbf{V}] \quad (41)$$

Where $[\mathbf{H}]$ is the frequency response function matrix, $[\mathbf{U}]$ is left singular matrix (unitary), $[\mathbf{\Sigma}]$ is singular matrix (diagonal) and $[\mathbf{V}]$ is right singular matrix.

From the options listed above it was used for processing the measurement results the CMIF method. Exported results from the measuring software have been imported into Matlab program. Source of code for processing the measured data was created from [33], where it was only a slight modification.

The resulting graph of FRF obtained using the CMIF method it can be seen in Fig. 46.

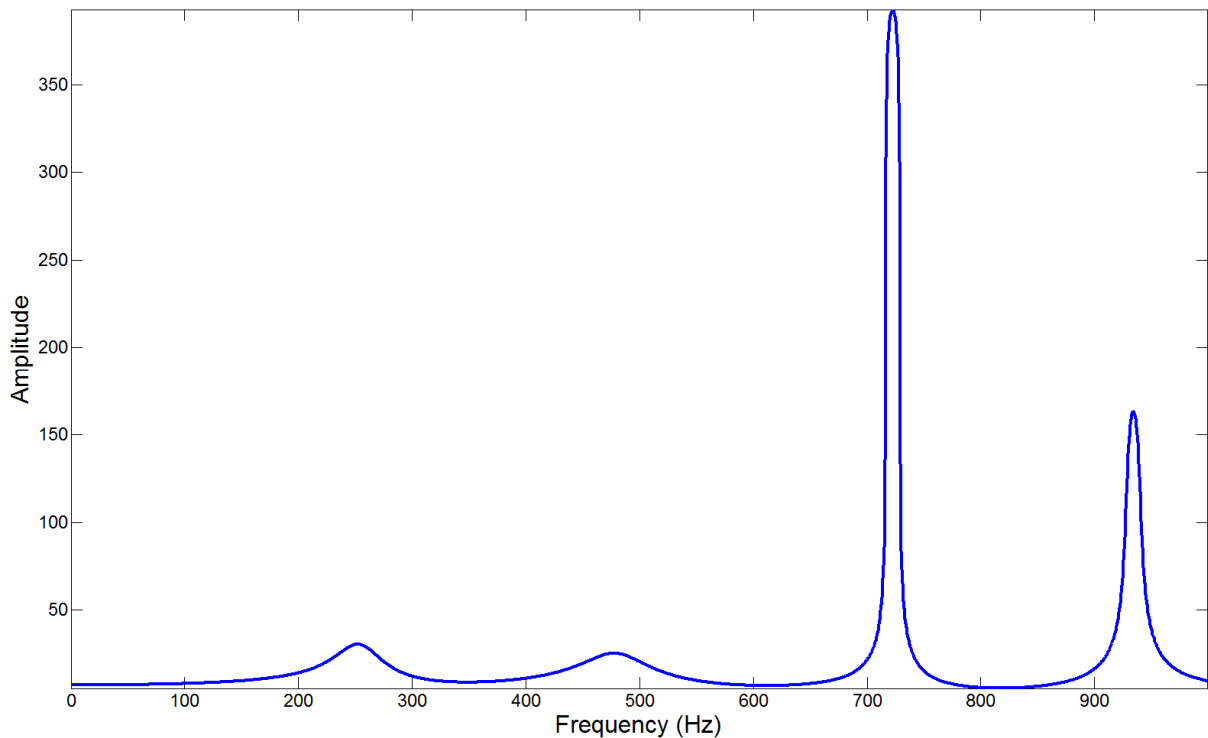

Figure 46 Reconstruction FRF from measurement data using CMIF method

In order to simplify the determination of natural frequencies from the waveform of the calculated FRF, it is also used the code from [33], implemented in Matlab. Method of finding natural frequencies is iterative, when the values are compared in three adjacent frequencies. If the mean value is the largest, then it is defined as the natural frequency. After that Matlab displays the number of found natural frequencies and their values.

For verification of the accuracy of the number of natural frequencies, it is used the method MAC (Modal Assurance Criterion).

The modal assurance criterion matrix is a mathematical tool to compare two vectors to each other. It can be used to investigate the validity of estimated modes.

The MAC between two mode shape vectors $\{\psi\}_r$ and $\{\psi\}_s$ is defined as:

$$MAC(\{\psi\}_r, \{\psi\}_s) = \frac{(\{\psi\}_r^{*T} \{\psi\}_s^{*T})^2}{(\{\psi\}_r^{*T} \{\psi\}_r) (\{\psi\}_s^{*T} \{\psi\}_s)} \quad (42)$$

The MAC will approach the value 1 if $\{\psi\}_r$ and $\{\psi\}_s$ are the same mode shape. If $\{\psi\}_r$ and $\{\psi\}_s$ are different mode shapes, the MAC value should be low, due to the orthogonality condition of the mode shapes.

In Fig. 47, it can be seen a preview of the MAC. For the calculation of the MAC in Matlab, it was used code from [33].

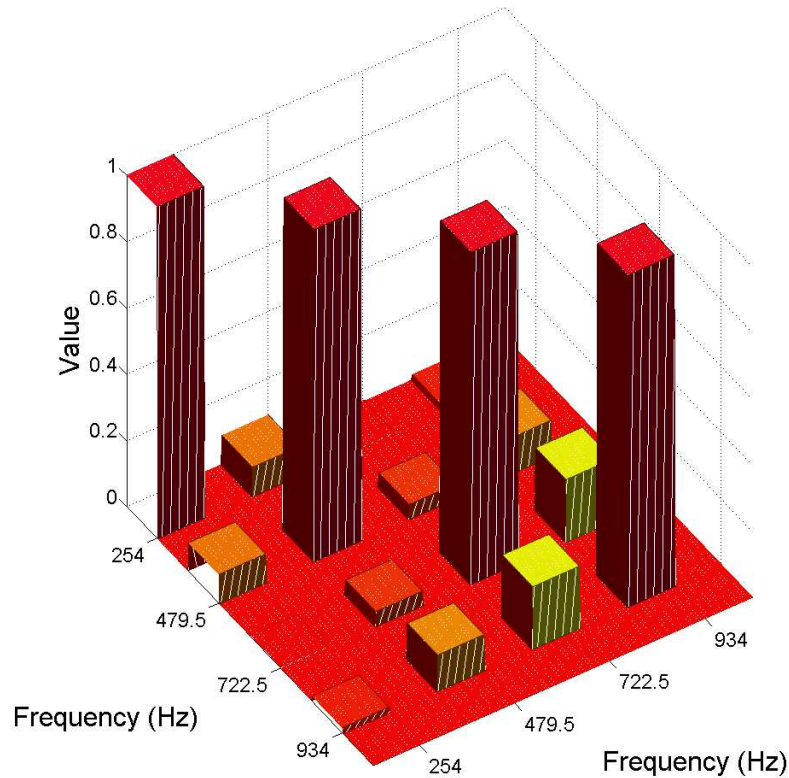

Figure 47 Modal Assurance Criterion

The last step in the evaluation of FRF measurements is to determine the parameters of damping, which are then used for calculation in the FEM or MBS program

In the determination of the proportional damping for the natural frequencies is used the graph obtained by CMIF method. Value of proportional damping it is determined by subtracting from this graph using the method of half power. As damping, it was chosen the proportional damping, which is mainly used for computational modelling [28]. The assumption is:

$$\mathbf{B} = \alpha \mathbf{M} + \beta \mathbf{K}, \quad (43)$$

where α , β are Rayleigh Damping coefficient.

In the experimental determination of the natural frequencies and the proportional damping, it can occur three basic cases [28]:

- 1.) there are known the natural frequencies and the proportional damping from two forms of vibration. The coefficients are determined by a system of two algebraic equations:

$$\begin{bmatrix} 1 & \omega_1 \\ \omega_1 & \omega_1^2 \end{bmatrix} \begin{bmatrix} \alpha \\ \beta \end{bmatrix} = \begin{bmatrix} 2\zeta_1 \\ 2\zeta_1 \omega_1 \end{bmatrix}. \quad (44)$$



- 2.) there are known the natural frequencies and the proportional damping from only one form of vibration. The second equation is determined by assuming that in the vast majority of technical applications is at least damped the lowest form of vibration. Hence from the condition of extreme, it can be determined following equation:

$$\begin{bmatrix} \frac{1}{\omega_1} & \omega_1 \\ \frac{1}{\omega_1^2} & 1 \end{bmatrix} \begin{bmatrix} \alpha \\ \beta \end{bmatrix} = \begin{bmatrix} 2\zeta_1 \\ 0 \end{bmatrix}. \quad (45)$$

- 3.) there are known the natural frequencies and the proportional damping from more than two forms of vibration. The coefficients are determined from the overdetermined system of algebraic equations

$$\begin{bmatrix} \frac{1}{\omega_1} & \omega_1 \\ \vdots & \vdots \\ \frac{1}{\omega_n} & \omega_n \end{bmatrix} \begin{bmatrix} \alpha \\ \beta \end{bmatrix} = \begin{bmatrix} 2\zeta_1 \\ \vdots \\ 2\zeta_n \end{bmatrix}. \quad (46)$$

Depending on the case, it is used method for determining of the coefficients α and β .

The final task is to determine the proportional damping for the entire frequency range. There also exists several ways [29]. In this thesis, it was used the method when in the calculation are used the values of the maximum, minimum and mean natural frequency. The calculation of total proportional damping is then determined by:

$$\zeta_i = \frac{\zeta_m - \zeta_1}{\omega_m - \omega_1} (\omega_i - \omega_1) + \zeta_1. \quad (47)$$

Using the processing of data which has been obtained from experiment, it was found by using Matlab the essential dynamic properties of structures that subsequently input into the calculation model and thus enhance its accuracy.



5 PROCESSING AND VISUALIZATION OF MEASUREMENT RESULTS AND CALCULATION

This chapter will describe the method of processing the results obtained by FEM or MBS analysis and based on this, determination of acoustic parameters of examined object. As mentioned above, for obtaining of acoustic parameters it is essential to set the normal velocities of surface vibration. Therefore, in this work as a benchmark it is used just the normal velocity.

The methodology is based on the fact that the CAD model is using specialized software discredited to finite element mesh. Using the FEM program ANSYS is then performed the harmonic analysis and its results together with a description of the mesh are processed, resulting in normal velocities of surface vibration. As a visualization tool, it is selected the program ParaView. A detailed description of the individual steps is listed below.

5.1 PROCESSING OF FE MESH

For the creation of the 3D parametric model, it is used program Pro/Engineer, which is in the powertrain design one of the most commonly used. The created model is then exported into a neutral format, which allows further processing.

For the creation of finite element mesh, it is used ICEM program. Using this program is created a mesh, defined components, contacts and material properties. Final version of the mesh is further processed in the FEM program ANSYS.

In the ANSYS program, there are on the examined object applied boundary condition and load. In the calculation, it is determined the response of the structure to the periodic excitation at the defined points. As a load, it is possible to use the results of MBS analysis, which should be converted from time domain to the frequency domain using Fourier analysis. If no results of MBS analysis are available, it is also possible to use basic load in the form of sine wave power.

In defining the parameters of calculating it shall be set the initial and final frequency and frequency step. Also, the main parameters affecting the accuracy are the damping properties, which can be obtained by the method mentioned in the previous chapter.

The results of harmonic analysis are coordinated components of deformation depending on the frequency. These results except the certain examples of models do not correspond to acoustic properties of the examined object. Therefore, it is necessary to process the results.

For that reason, it is necessary to export the results in a reasonable format in which can be further processed. For this purpose were created macro files into the ANSYS.

The first macro file exports the finite element mesh. In export, it was used information obtained in [30]. The resulting exported file in the header contains the name of the FEM model. In another part, there are the information about the number of exported nodes and then are listed the numbers of individual nodes together with their coordinates. Another part of the file contains information on the walls (faces) of the individual elements, where in the first



column is the number of the element and in the other columns are numbers of elements with a common wall (face). The last part is the list of elements, that contains the number of element and numbers of nodes by which is formed.

```

plate_1_
NODES
 1914.
 1. -0.100000E+03 0.000000E+00 -0.100000E+01
 2. -0.916381E+02 0.000000E+00 -0.100000E+01
 3. -0.100000E+03 0.809055E+01 -0.100000E+01
 4. -0.916381E+02 0.809055E+01 -0.100000E+01
 5. -0.100000E+03 0.000000E+00 0.100000E+01

FACE
 892.
 1. 0. 0. 31. 2. 0. 0.
 2. 0. 1. 32. 3. 0. 0.
 3. 0. 2. 33. 4. 0. 0.
 4. 0. 3. 34. 5. 0. 0.
 5. 0. 4. 35. 6. 0. 0.
 6. 0. 5. 36. 7. 0. 0.

ELEMENTS
 892.
 1 2 4 3 5 6 8 7 1 1 0 0 0 1
 3 4 10 9 7 8 12 11 1 1 0 0 0 2
 9 10 14 13 11 12 16 15 1 1 0 0 0 3
 13 14 18 17 15 16 20 19 1 1 0 0 0 4
 17 18 22 21 19 20 24 23 1 1 0 0 0 5
    
```

Figure 48 Export file with FE mesh info

The resulting file is then processed using Matlab. As first, there are determined from the obtained file the walls (face), which form the surface of the object (there are included also the inside walls and holes in walls). Subsequently, it is determined a surface area element. A crucial step is the determination of the normals. This is divided into two steps, where in the first one it is determined the normal to the surface element by vectors formed by connecting of nodes forming the element. The second step is to determine the normal at the node. Whereas one node usually consists of more elements, in determining of the final normal it is found the final vector from vectors generated by multiplying the normal to the element containing that element.

Principle of the determination of the normals to the element it is shown in Fig. 49 where the method is presented on a single 2D example.

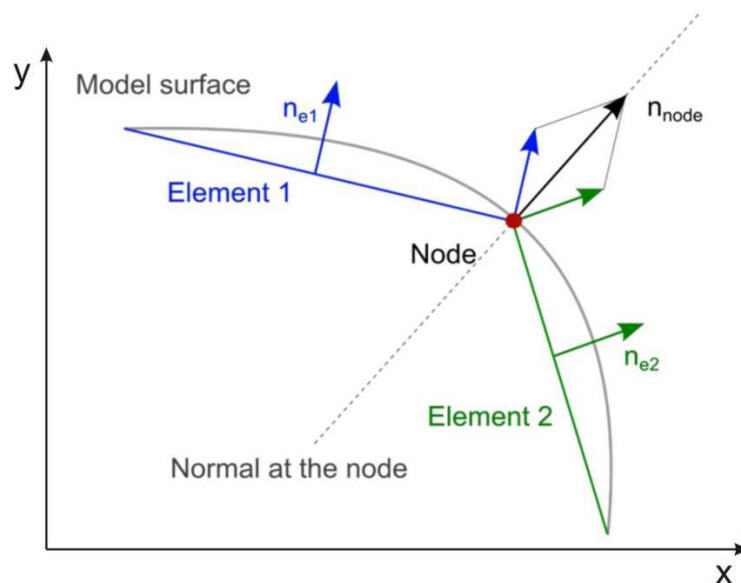

Figure 49 Calculation of normal vector



The second macro file exports the results of harmonic analysis. In the first line, the file contains also the name of the FEM file. In the next line, there are the information about the number of exported frequencies, number of nodes and information about what a frequency is currently exported. In the next line, there are the results of harmonic analysis for each node and coordinate components of displacement at a particular node.

```
6U_engin
NUM_RES
  100.
NODES
  190784.
FREQ
  1.      0.100000E+01
RESULTS
  1.      -0.323758E-01      0.344107E+00      -0.444535E-01
  2.      -0.323540E-01      0.344132E+00      -0.349885E-01
  3.      -0.331675E-01      0.352541E+00      -0.448096E-01
  4.      -0.331402E-01      0.352551E+00      -0.355193E-01
  5.      -0.324583E-01      0.344527E+00      -0.553922E-01
  6.      -0.324136E-01      0.344562E+00      -0.387309E-01
  7.      -0.332471E-01      0.353100E+00      -0.552461E-01
  8.      -0.332024E-01      0.353134E+00      -0.385614E-01
```

Figure 50 Export file with results of harmonic analyses

Also, this file is then processed by Matlab. The values of displacement for individual frequencies are converted into velocity. From the coordinate components of velocity, it is calculated the resultant velocity vector at that node.

The last step is the conversion of the resultant velocity vector into the direction of the normal vector at that node. The principle can be seen on the 2D case in Fig. 51.

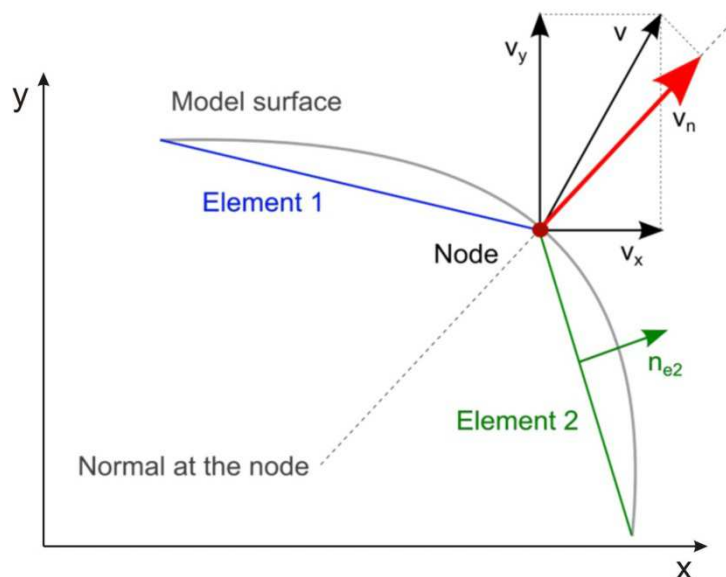

Figure 51 Calculation of normal velocity



5.2 ANALYSIS OF THE VELOCITY OF SURFACE VIBRATION

From the results obtained by the previous method, it is detected surface vibration at specified frequencies in certain nodes. However, for more detailed evaluation it is sometimes necessary to find out the integral characteristics in a certain frequency range or to have available one number representing the properties of the examined object. In the mutual comparison, it is also used the waveform of velocity of vibration throughout the structure depending on frequency.

Determination of individual acoustic parameters depends on whether it is a node, component or eventually complete assembly of the analysed object. However, in each of these cases are analysed the normal velocities and the surface of the object. Distribution and mutual connection can be seen in Fig.52. [31]

	Selected nodes	Surface distribution	Components (Mean value)
Single-frequencies		v_n^2 dB[A]	
Frequency-distribution	v_n^2 dB[A]		$\sum_{ob} v_n^2$ $\sum_{ob} dB[A]$
Frequency-integrals	$\sum_{fr} v_n^2$ $\sum_{fr} dB[A]$	$\sum_{fr} v_n^2$ $\sum_{fr} dB[A]$	$\sum_{ob} \sum_{fr} v_n^2$ $\sum_{ob} \sum_{fr} dB[A]$

Figure 52 Overview of possible results [31]

To calculate the acoustic parameters are according to [31] used the following relations:

Mobility:

$$E[x^2] = \frac{1}{2} \sum_{f_1}^{f_2} v_n, \tag{48}$$

where v_n is normal velocity, f_1 is lower frequency and f_2 is upper frequency.

Surface noise level in dB [31]:

$$L_v[dB] = 10 \log \frac{(E[x^2])_{f_1}^{f_2}}{v_{ref}^2}. \tag{49}$$

5.3 VISUALIZATION OF RESULTS

After processing of the measurement results and determination of the acoustic parameters, it is, in addition to an integral number, describing the level of acoustic noise areas or graph of



dependence of vibration on the frequencies, also the visualization of the entire surface in 3D space.

In the initial phase of the testing of chosen procedure, the visualization was carried out using Matlab. However, this solution showed significant impracticability for large objects, because that from size of the mesh around 3000 nodes, there was an inability to rotate and zoom in Figure in MATLAB program.

For this reason, it has been chosen as a postprocessor, program ParaView. This program is free, and it is used to visualize a wide range of scientific applications.

For purposes of this work, it was chosen as the input file, the file with suffix *.vtk. Description of this file is given in [32]. The advantage of this file is that it allows visualizing different types of elements and also the results of analyses related to the nodes or elements, by using the colour range. Another advantage is the fact, that this file uses for the description of the geometry a similar principle as ANSYS and thus the conversion of the exported file from ANSYS into the ParaView, was relatively easy to apply. Writing of *.vtk file was also carried out using Matlab.

In Figure 53, it can be seen a sample result of harmonic analysis of the real parts.

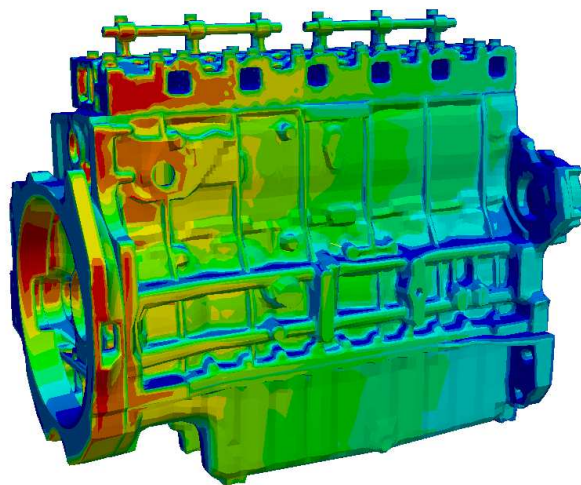

Figure 53 Normal velocity visualization



6 EXAMPLES OF PRACTICAL APPLICATION OF METHOD

This chapter will show examples of using the above listed procedures to real objects. In the first part, it is a single flat metal plate with ribs. Next section describes the cover of valvetrain for 4 cylinder diesel engine Zetor. In the last part, there is the sample of processing the results of MBS analysis for 6 cylinder diesel engine Zetor.

6.1 THE VERIFICATION OF PROCESS FOR A SIMPLE CASE

Flat metal plate was selected because of its easy production and the possibility of a simple verification of models.

Verification of the chosen methodology is implemented on two experimental models. The first model is a flat metal plate and the second one is a metal plate of the same dimensions but with added rib in the form of welded belts. Experimental models can be seen in Fig. 54

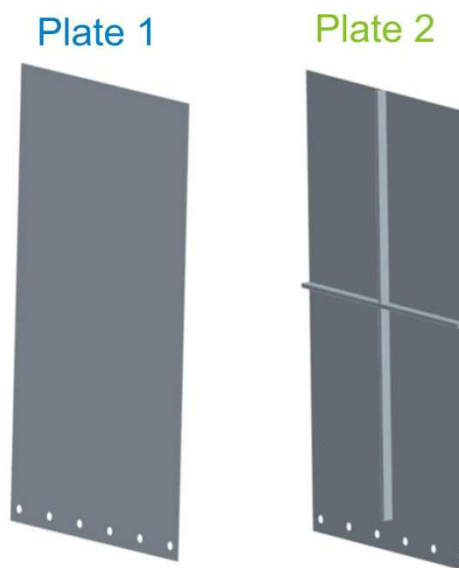

Figure 54 Experimental models

On the experimental models, it is created a mesh of points at which the measurement is then performed. Excitation is positioned eccentrically to the center of metal plate. Mounting is solid and fixed. Measured samples are securely fixed to a steel plate. Electrodynamic vibration exciter is placed freely by using steel chains. Scheme of measurement can be seen in Fig. 55.

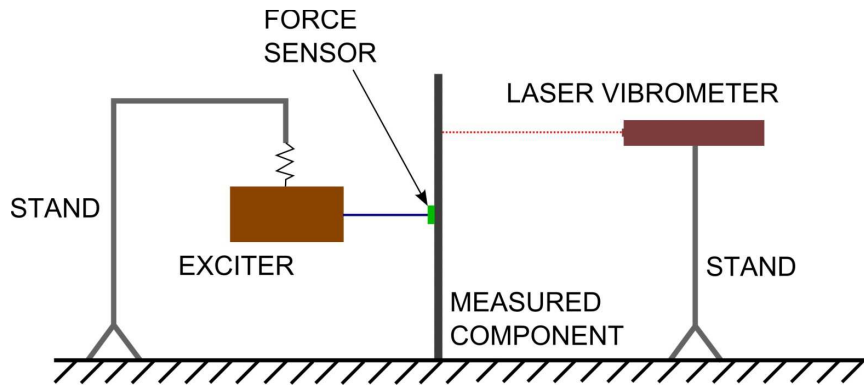

Figure 55 Scheme of measurement

For scanning of displacements, it is used the laser scanner POLYTEC 4000 Series Laser Vibrometer, as the recording device it is used Compact PULSE data acquisition unit. For saving, processing, visualization and control, it is used software PUPULSE™ 13. The real experimental arrangement can be seen in Fig. 56.

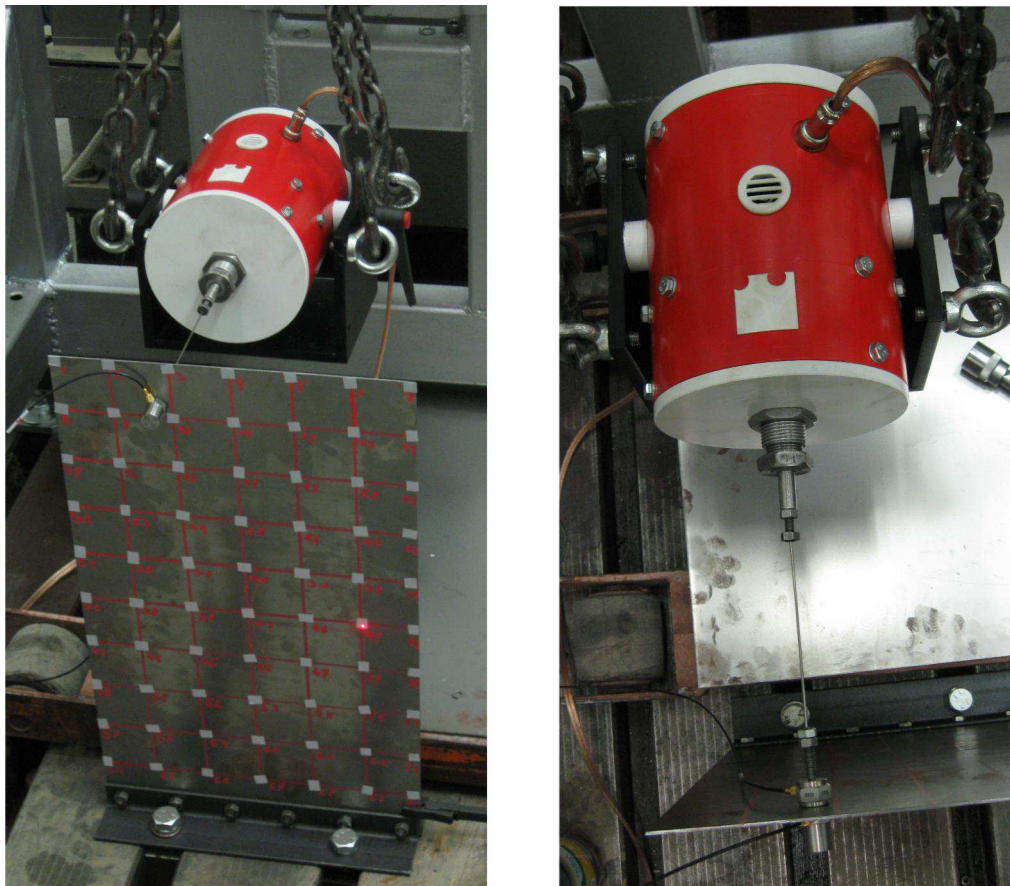

Figure 56 Real experimental arrangement



The next step is the comparison of velocity of surface vibration investigated by measuring and calculated using the harmonic analysis when using the sine wave power 10 N. In Figure 57, it can be seen the results for the frequency of 30 Hz, 110 Hz and 260 Hz.

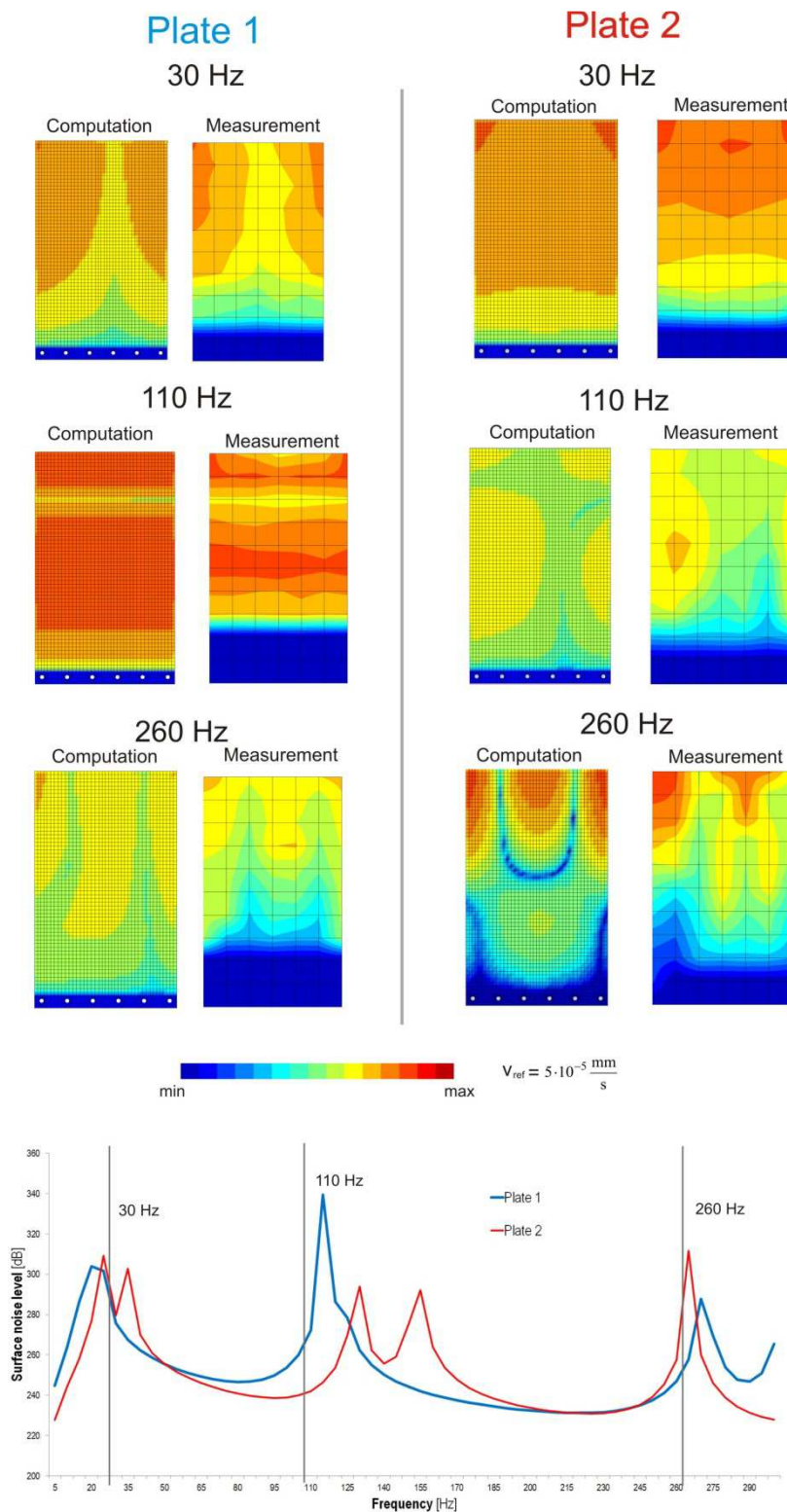

Figure 57 Comparison results of calculations with experiment



The final task is to compare the results throughout the frequency range. In Figure 58, it is visualized the calculated waveform of mobility for the entire measured object, depending on frequency.

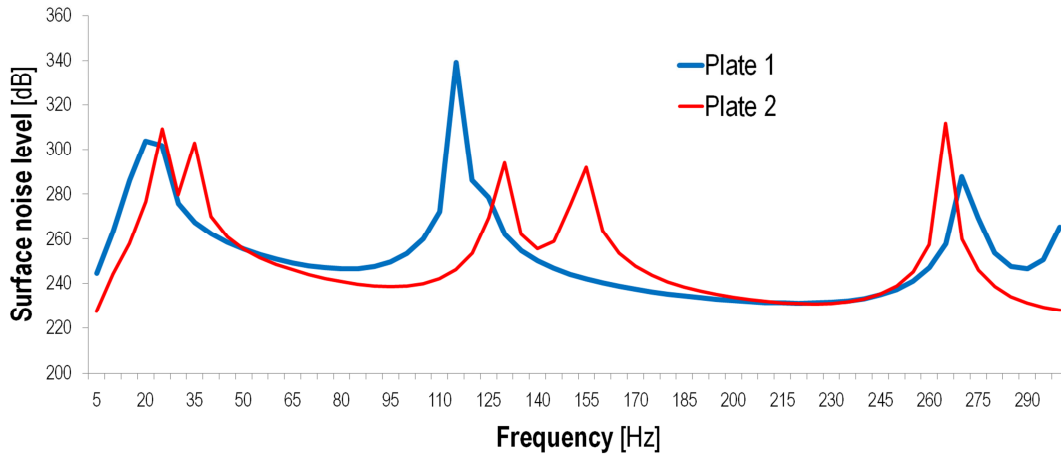

Figure 58 Calculated integral mobility

Visualization of calculated velocity of surface vibration for examined objects throughout the frequency range is shown in Fig. 59 .

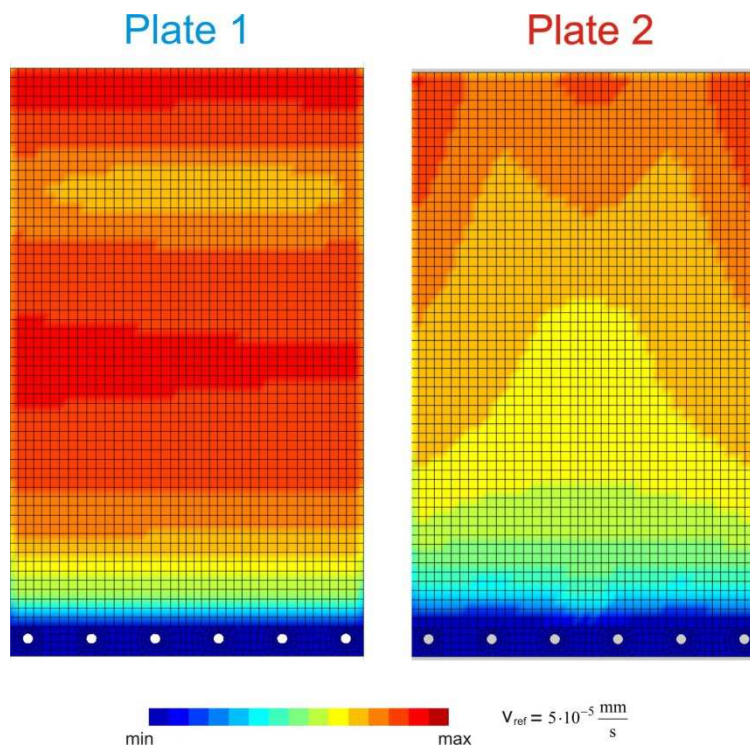

Figure 59 Calculated integral mobility



The detected results qualitatively meet the expectations. The metal plate with added rib is in terms of vibration and noise more favourable. The calculated and measured values in decibels are relatively high. This is because of that, the loading force was in comparison with the stiffness of metal plate vast and metal plate had a significant displacement (in several mm). This way of the load it has been chosen because of the possibility of visual control of the real vibration, where real form of metal plate deformation at the selected frequencies is identical to the calculated and measured normal velocities.

6.2 THE COVER OF VALVETRAIN OF THE ZETOR ENGINE

Another example is the detection of dynamic properties of the cover of valvetrain four-cylinder diesel engine Zetor. Preview of the cover can be seen in Fig. 60 .

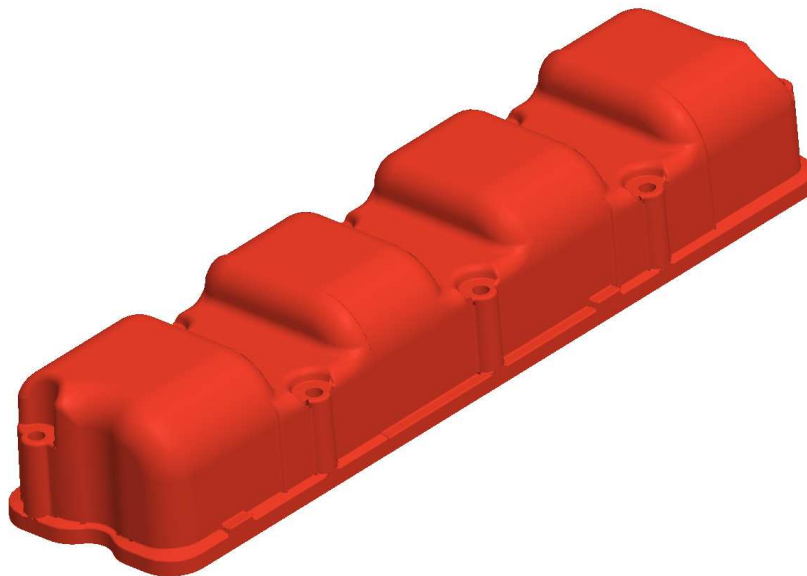

Figure 60 Cover of valvetrain of the Zetor engine

The measurement is performed using the same apparatus as in the previous case. The difference is in the excitation signal and also in how to fix the cover and the electrodynamic vibration exciter. In the previous case, it was used the continuous frequency sweep. In the measurements of the cover, it was used the white noise. Arrangement of the measuring chain it can be seen in Fig. 61 .



Figure 61 Arrangement of the measuring

The measurement results are again processed using Matlab and comparison of natural frequencies can be seen in Table 7 .

Tab. 7 Results of measurement and calculation

Number of Mode	Measurement	Calculation	Damping Ratio
1	254 [Hz]	285 [Hz]	0,076
2	480 [Hz]	457 [Hz]	0,017
3	722 [Hz]	730 [Hz]	0,013
4	934 [Hz]	839 [Hz]	0,012

This measurement is carried out in order to determine the dynamic properties, which are subsequently used in the following example.

Tab. 8 Damping variable

Variable	Value
α	250,7
β	$-3,19 \cdot 10^{-6}$
ζ	0,031



6.3 VIRTUAL ENGINE

The last sample is the application of the evaluation and visualization on the six-cylinder engine Zetor. The input data represent a finite element mesh, alpha, beta, proportional damping, and as the load there are used the results of the virtual engine.

Due to the fact, that the entire engine block is made of the same material as a cover of valvetrain in the previous case, the dynamic properties alpha, beta and proportional damping are applied from the above used results.

For the calculation of virtual engine in MBS but also in measuring, it has been the engine fixed on silent blocks. These silent blocks were simulated using support in the extreme points of the engine. For the supports, it is defined the stiffness of 50 000 N/mm and the damping of 100 Ns/mm. The resulting finite element model together with supports is in Fig. 62 .

As first it has been performed the modal analysis. Sample of the resulting forms and frequencies is shown in Fig. 62 .

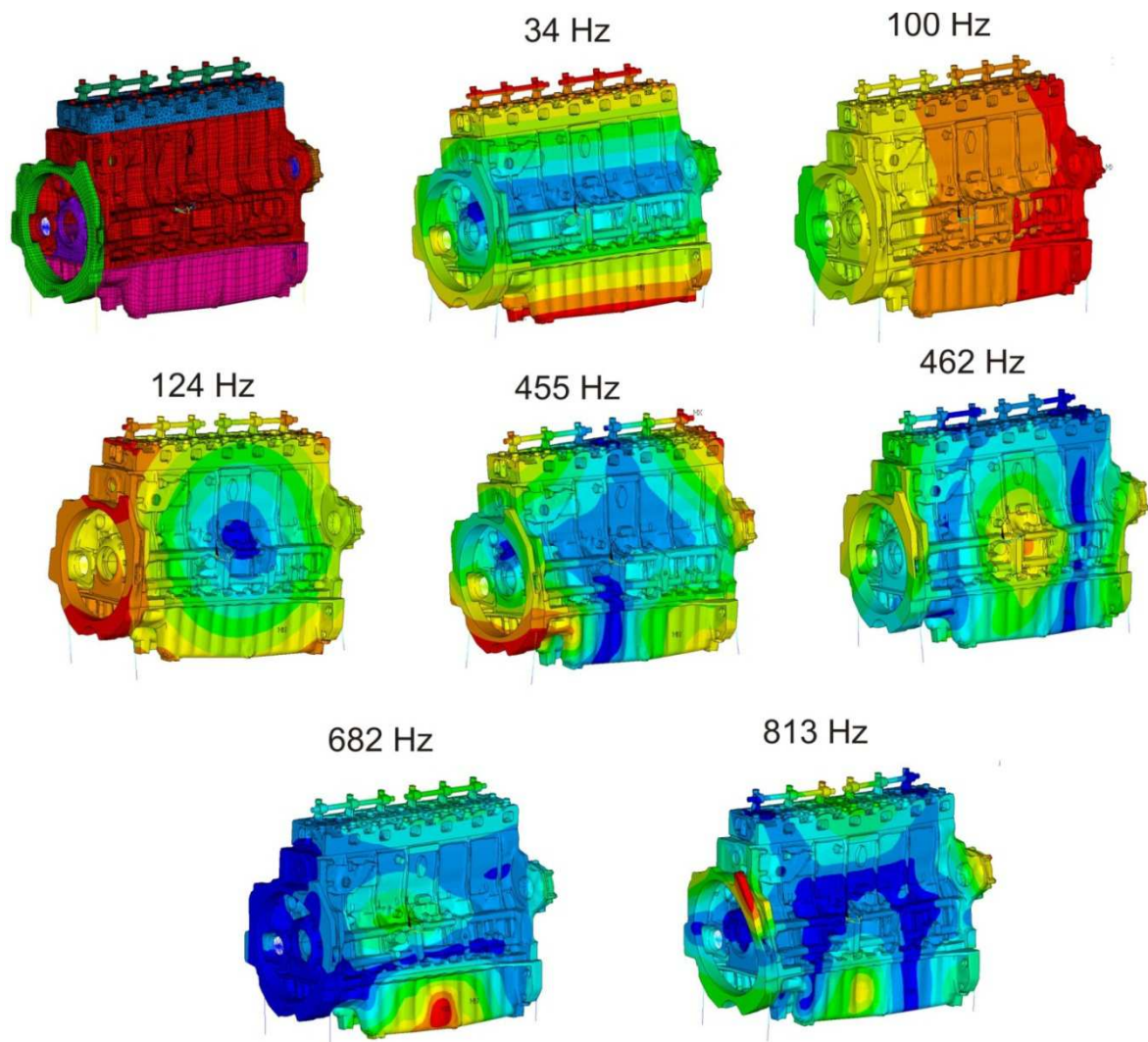

Figure 62 Results of modal analysis



From the results of simulations of virtual engine are obtained coordinate components of forces in the bearings of crankshaft and the forces in the liners of cylinders. For the purposes of harmonic analysis, it is necessary to transfer these forces from time domain to the harmonic components. The transfer is carried out by using the Fourier analysis. Examples of plotted forces in the time it is shown in Fig. 63 .

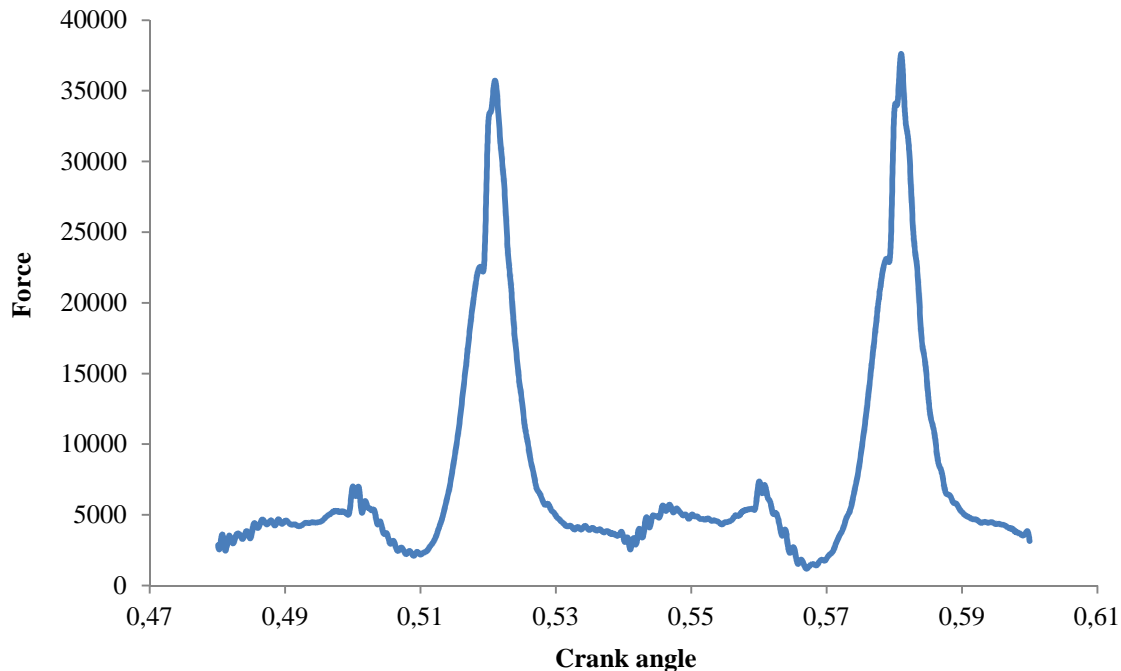

Figure 63 Example of load force

Because this is a relatively large number of load nodes and harmonic components, the entire process was automated by using Matlab. Inputs to Matlab are waveforms of components of forces, and the output is macro into the ANSYS that implements the load on the defined points.

Harmonic analysis is made from 0 Hz to 1000 Hz with the step of 10 Hz. Due to the fact that this is a comprehensive model containing elements of 228 085 and 190 927 nodes, the harmonic analysis is performed only for two revolutions 1600 min^{-1} and 2200 min^{-1} .

Calculations have been performed at 4 core PC with processors 2,4 GHz and RAM memory with size of 4,0 GB. Duration of harmonic analysis together with the time necessary to export the results for one revolution took 25 hours. Processing of the exported results took 38 hours.

Given that during the experiment and writing of this work, it was not available any measuring device for visualizing of the surface vibration (acoustic camera), the calculated results have been compared with results obtained in [1]. In that publication is the Campbell diagram of normal velocity at the point of the engine block surface (see Fig. 64).

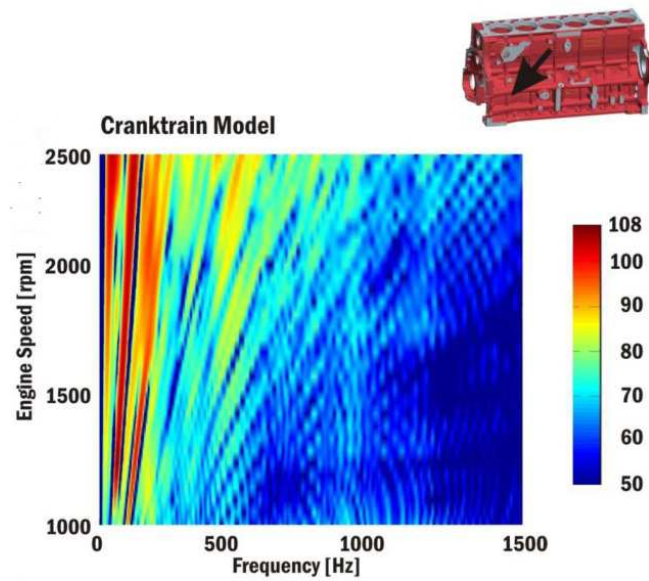

Figure 64 Campbell diagram of normal velocity of crankcase

In the figures below, there are pictures representing the comparison of normal velocity vibration of engine's surface for the selected revolutions at selected frequencies.

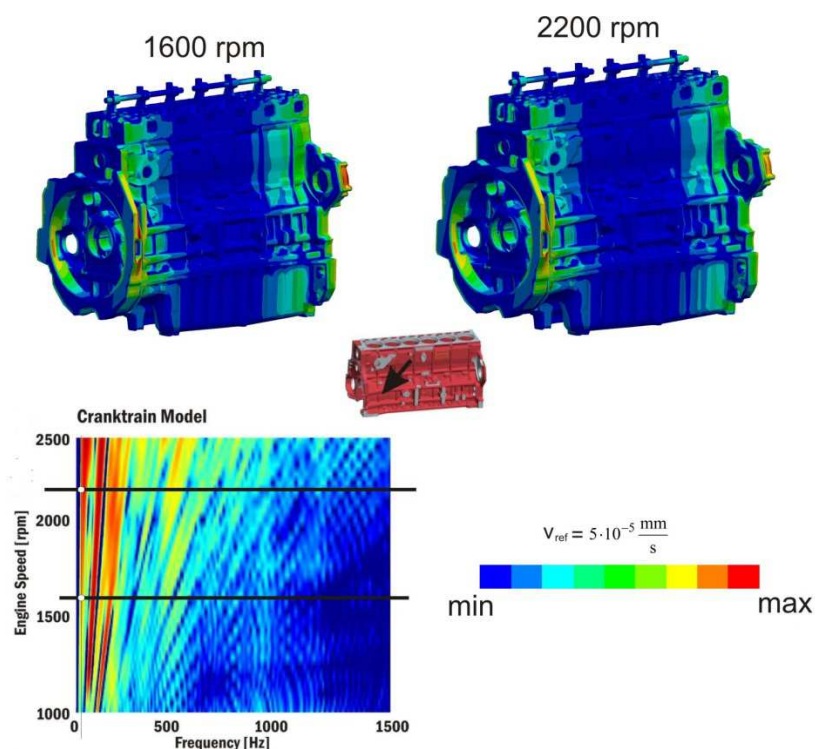

Figure 65 Mobility for 30 Hz

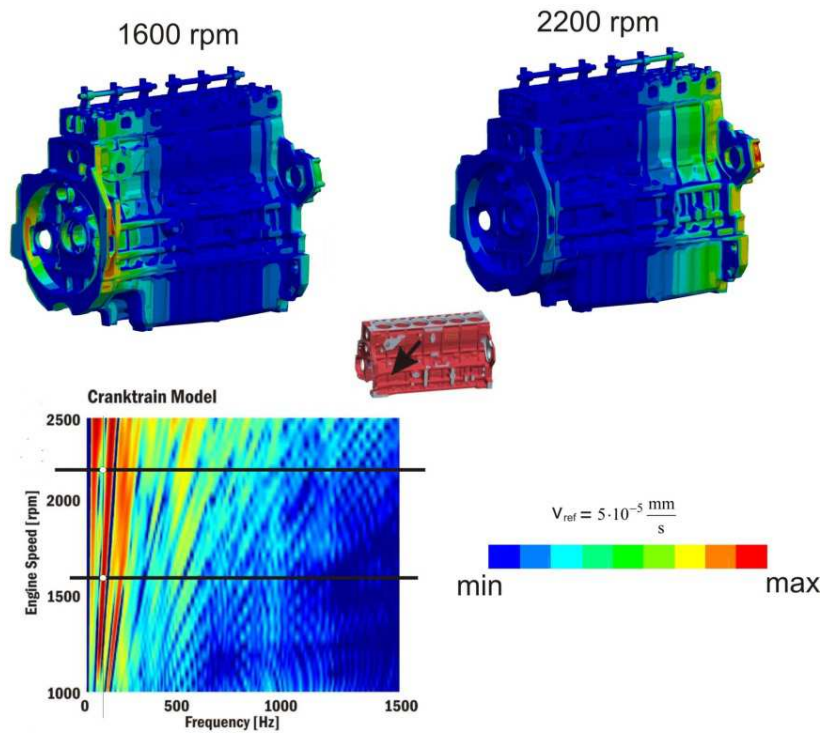

Figure 66 Mobility for 90 Hz

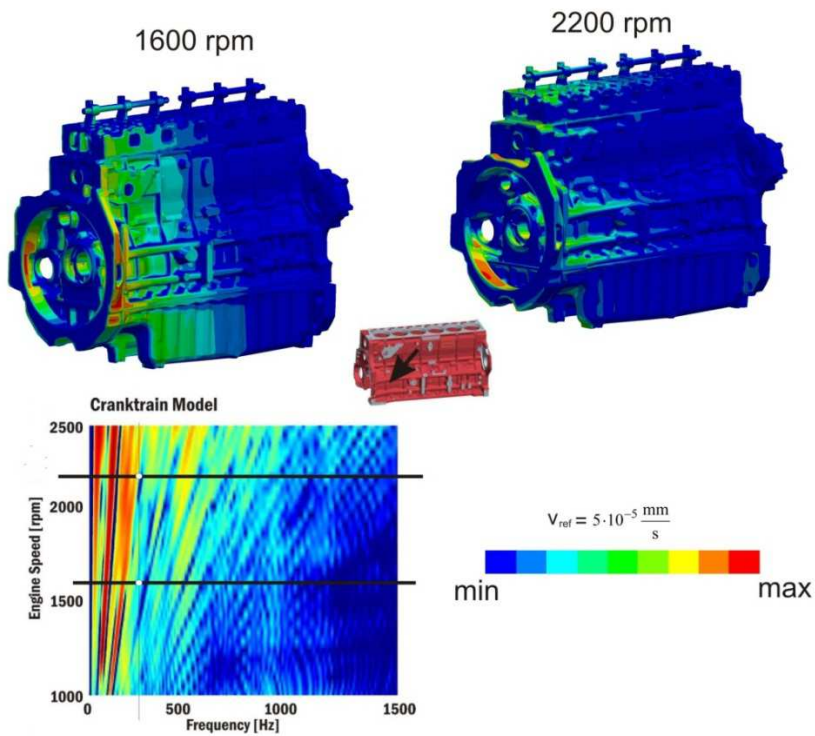

Figure 67 Mobility for 250 Hz

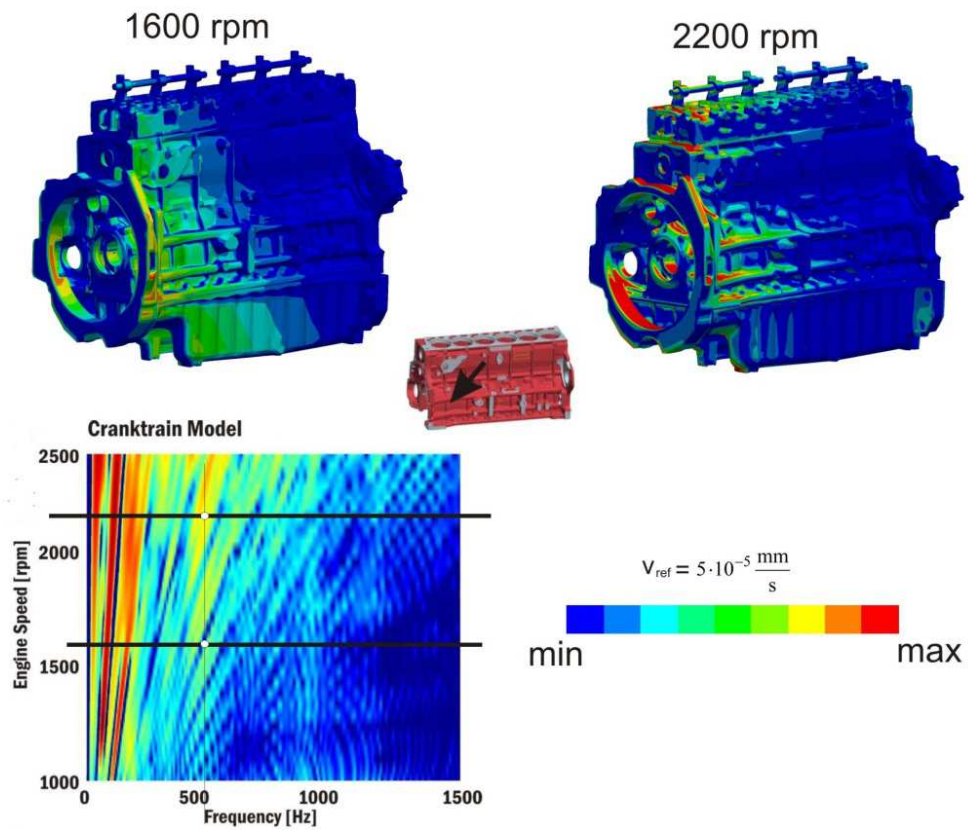

Figure 68 Mobility for 540 Hz

From the above pictures, in comparison with the results in the Campbell diagram it can be seen, that for the visualized point are the results qualitatively consistent.

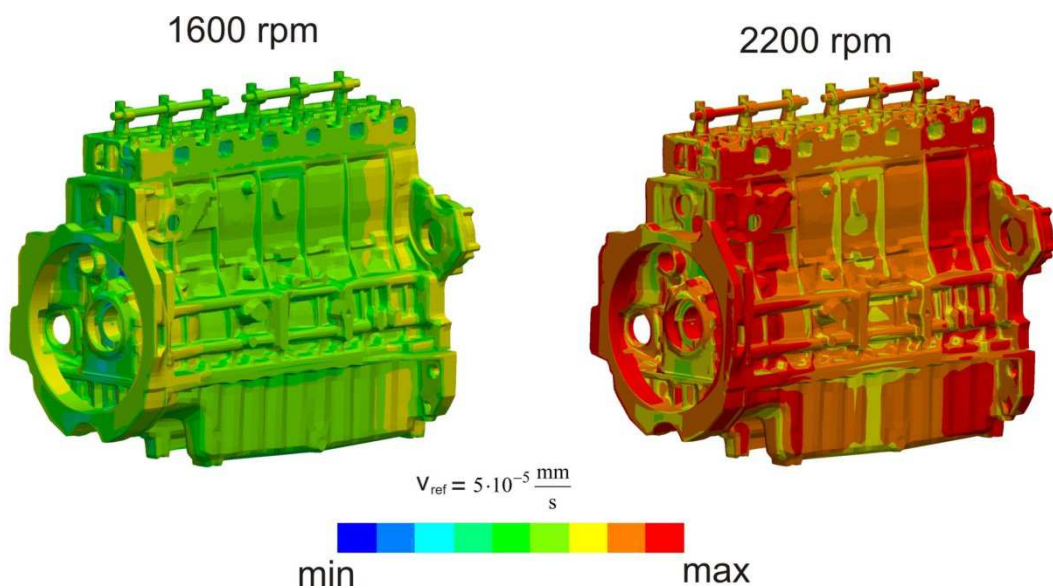

Figure 69 Surface noise level



Integral vibration of surface for the frequency range and revolutions it is shown in Fig. 69. The characteristic value for the whole engine, it is the mobility, which in case 1600 min^{-1} is 90,66 dB and in case 2200 min^{-1} is 133,65 dB.



CONCLUSION AND DISCUSSION

In presented thesis, it is at the beginning described in detail the theoretical and physical basis of noise and vibration. Following are common methods of solving the issue of combustion engines.

In the next section, it is presented a design of electrodynamic vibration exciter, which is used for experimental verifying of calculations and determination of dynamic properties of the structure. The principle of the method bases on processing the results of harmonic analysis. Detailed description gives the chapter 5. In the last chapter is on three examples shown a possible use of the method and presented potential pitfalls and problems. One of the examples is purely experimental and others present method of solving practical problems.

The above mentioned examples describe the method and the way of determining the acoustic properties of either the powertrain or its individual components. Accurate qualitative comparison was not possible to make due to the insufficient laboratory equipment. However, the method has adequate compliance of experiment and measurements for qualitative comparison.

By this procedure, it is possible to determine the quantitative levels of generated acoustic emissions and thus the mutual comparison of individual engineering designs. This would require the use of modern methods of visualization, which is the acoustic camera. On the other hand, it should be also included in the calculations other elements that influence the noise and vibrational characteristics of objects or the whole structure. To the most basic, it is possible to include the impact of the operating fluid, changing of properties depending on temperature and as well impact of internal interaction of excitation to the spread of vibration and noise.

The advantage of this method is mainly the relative simplicity and speed of comparison of individual load step, variants or other modifications. In using of implementation as indicated in this work, is this solution unsatisfactory for complicated structures (see the time of the calculation of engine). Speed up of calculation by using the FEM is possible only by reduction of model. This can be achieved by simplifying or omitting structural details or by coarser mesh. However, both solutions involve the increasing of uncertainty of the calculation. The second way to speed up, it is to use for processing of the calculated results another way. As appropriate, it appears to rewrite a debugged source code either from Matlab to C++ or to Fortran. In them, it is possible to speed up the calculation in some cases more than 10 times.

This thesis presents initial analysis and a one of possible approaches to the analysis of acoustic properties. It is not based on direct evaluation of generated noise, but on the evaluation of surface vibration. The work is the basis for future development to solving the issue. The development could move towards the use of normal velocities to obtain the changes of the acoustic pressure around the investigated object. Another option is to focus on increasing the accuracy of calculation results. One option is also extension of the method on the determination of the dynamic properties of the system, and creation a basic database of these parameters that would be used in the design of new engineering solutions in the future.

The objectives of the dissertation thesis, which was specified at the beginning, have been met. The result is a designed method of evaluation of noise (vibration), with the basic application



and presentation of the results. The whole method is created in such a way that allows its use by the free software; therefore it is open to further development.



REFERENCES

- [1] NOVOTNÝ, P. *Virtual engine – a tool for powertrain development*, Habilitation Thesis. Brno: Brno University of Technology. ISBN: 978-80-214-3666-5, 2009, 94 p.
- [2] SVÍDA, D. *Snižování vibrací a akustických emisí pohonných jednotek aplikací virtuálního motoru*. Brno: Vysoké učení technické v Brně, Fakulta strojního inženýrství, 2011. 95 s. Vedoucí dizertační práce prof. Ing. Václav Píštěk, DrSc.
- [3] SMETANA, C. a kol.: *Hluk a vibrácie, Měření a hodnocení*. Sdělovací technika, Praha 1988. ISBN 80- 901936-2-5.
- [4] NOVÝ, R. *Hluk a chvění*, České vysoké učení technické, 2000, 389s., ISBN 9788001022467
- [5] HASSAKK, J. R., Zaveri, Z. *Acoustic Noise Measurements*, Bruel and Kjaer, Copenhagen (1979).
- [6] BIES, D. A., HANSEN, C. H. *Engineering Noise Control Theory and practice*, Taylor & Francis, 2009, ISBN 0415487064.
- [7] KELLY, S. *Mechanical vibrations: theory and applications*. 1st Ed. Mason, OH: Cengage Learning, 2011, p. cm. ISBN 9781439062128.
- [8] MIŠUN, V. *Vibrace a hluk / 2. vyd.* Brno : Akademické nakladatelství CERM, 2005. 177s. ISBN 80-214-3060-5.
- [9] BEIDL, C. V.; RUST, A.; RASSER, M. *Key Steps and Methods in the Design and Development of Low Noise Engines*. SAE technical paper series. 1999-01-1745.
- [10] Fahy, F., *Foundations of Engineering Acoustics*. Academic Press, London, UK, (2001) ISBN 0-12-247665-4.
- [11] Bruel and Kjaer. Prednášky zo školenia. Hrotovice. 15.3.2011
- [12] Západočeská univerzita v Plzni. *Laserova vibrometrie*, [online] [cit. 2011-4-11] URL:< <http://home.zcu.cz/~krivanka/vat.png>>.
- [13] Bruel and Kjaer, *Microfon Handbook*. Vol.1 Theory. BE 1447 –11. Denmark. July 1996.
- [14] LANSLOTS, J., DEBLAUWE, F., JANSSENS, K. *Selecting Sound Source Localization Techniques for Industrial Applications*. SOUND & VIBRATION/JUNE 2010. [online] [cit. 2011-4-11] URL:< <http://www.sandv.com/downloads/1006lans.pdf>>.
- [15] Bruel and Kjaer, *PULSE Array-based Noise Source Identification Solutions: Beamforming — Type 8608, Acoustic Holography — Type 8607, and Spherical Beamforming — Type 8606*. PRODUCT DATA. BP 2144 – 15.
- [16] STEFFENS, CH.; NUSSMAN, CH. *Virtual product development techniques applied to powertrain acoustics*. Autotechnology 1/2006.



- [17] BILOŠOVÁ, A., *Experimentální modální analýza*. Fakulta strojní. VŠB-Technická univerzita Ostrava.
- [18] BROWN, D., L., PERES, M., A. *Modal excitation*. Presentation. The Modal Shop, Inc. [online] [cit. 2011-4-11]
URL:<<http://www.modalshop.com/filelibrary/Modal%20Excitation%20Tutorial.pdf>>.
- [19] The Modal Shop, Inc., *Modal Shaker Selection Guide*. [online] [cit. 2011-4-12]
URL:<http://www.modalshop.com/excitation.asp?P=Modal_Shaker_Selection_Guide&ID=344>.
- [20] servo-drive.com. *Kmitající cívky řady AVM*. Product data. [online] [cit. 2011-4-11]
URL:<http://www.servo-drive.com/pdf_catalog/voice_coil_drives_avm_cs.pdf>.
- [21] BOSCH. *FSA 760 Edition Product information*. Product data. [online] [cit. 2011-4-11]
URL:<http://aa.bosch.de/advastaboschaa/Product.jsp?prod_id=428&ccat_id=70&language=en-GB&publication=3>.
- [22] Bruel and Kjaer. *Vibrační zkoušení*. Naerum, Dánsko. CZECH DK BB 0375-11.
- [23] The Modal Shop, Inc., *Vibration Shaker Selection Guide*. [online] [cit. 2011-4-12]
URL:<http://www.modalshop.com/excitation.asp?P=Vibration_Shaker_Selection_Guide&ID=339>.
- [24] TŮMA, J., *Experimentální modální analýza -Teorie*. studijní materiál. Západočeská univerzita v Plzni. Fakulta aplikovaných věd. [online] [cit. 2011-4-12]
URL:<http://www.kme.zcu.cz/jkana/soubory/Tuma_Modalni_analyza_mereni.pdf>.
- [25] DVOŘÁK, V., *Experimentální modální analýza SVOČ – FST 2009*. Západočeská univerzita v Plzni. Fakulta strojní. [online] [cit. 2011-4-20]
URL:<[http://old.fst.zcu.cz/_files_web_FST/_SP_FST\(SVOC\)/_2009/_sbornik/PapersPdf/Ing/Dvorak_Vitezslav.pdf](http://old.fst.zcu.cz/_files_web_FST/_SP_FST(SVOC)/_2009/_sbornik/PapersPdf/Ing/Dvorak_Vitezslav.pdf)>.
- [26] AVITABILE, P. *Modal space article In Our Own Little World*. University of Massachusetts Lowell. Modal Analysis and Controls Laboratory.
- [27] Zhao, X., Wu, S.,F., *Reconstruction of vibro-acoustic fields using hybrid nearfield acoustic holography*. Journal of Sound and Vibration. Volume 282, Issues 3–5, 22 April 2005, Pages 1183–1199.
- [28] MALENOVSKÝ, E. *Počítačové metody mechaniky v dynamice*. VUT v Brně. Fakulta strojního inženýrství. 22. září 2008. [online] [cit. 2011-8-20]
URL:<[http://old.fst.zcu.cz/_files_web_FST/_SP_FST\(SVOC\)/_2009/_sbornik/PapersPdf/Ing/Dvorak_Vitezslav.pdf](http://old.fst.zcu.cz/_files_web_FST/_SP_FST(SVOC)/_2009/_sbornik/PapersPdf/Ing/Dvorak_Vitezslav.pdf)>.
- [29] GIOSAN, I. *Dynamic analysis with damping for free-standing structures using mechanical event simulation*. Center for Mechanical Simulation Technology. [online] [cit. 2011-7-20]
URL:<http://www.algor.com/news_pub/tech_white_papers/dynamic_analysis/default.asp>.



-
- [30] ANSYS 12 Help.
- [31] MAGNA POWERTRAIN. FEMFAT NVH 3.1, User manual, Magna Steyr.
- [32] Vtk User`s Guide. *File Formats for VTK Version 4.2*. [online] [cit. 2012-4-11] URL:<
<http://www.vtk.org/VTK/img/file-formats.pdf>>.
- [33] VERBOVEN, P. *Frequency – domain system identification for modal analysis*. Vrije Universiteit Brussel, Faculteit Toegepaste Wetenschappen. May 2002.



SYMBOLS

BEM	[-]	Boundary Element Method
CAD	[-]	Computer Aided Design
CMIF	[-]	Complex Mode Indicator Function
FE	[-]	Finite Element
FEM	[-]	Finite Element Method
FRF	[-]	Frequency Response Function
IBEM	[-]	Inverse Boundary Element Method
MAC	[-]	Modal Assurance Criterion
MBS	[-]	Multi Body System
MIF	[-]	Mode Indicator Function
MMIF	[-]	Multivariate MIF
NAH	[-]	Near-Field Acoustics Holography
SUM	[-]	Sumation function
Σ	[-]	singular matrix (diagonal)
a	[m/s ²]	acceleration
a _f , b _f	[-]	vector of coefficients influence
b	[Ns/m]	damping
B (H)	[-]	viscous damping matrix (or hysteresis damping matrix)
c	[m/s]	velocity of moving disturbance
d	[mm]	electrodynamical exciter amplitude
D (k)	[-]	function of frequency
E[x ²]	[-]	mobility
f	[Hz]	frequency
F	[N]	force
g	[m/s ²]	gravitation constant; g=9,81 m/s ²
G	[-]	system
G (X,Y)	[-]	Green function between points X in space V and points Y
H	[-]	Frequency Response Function
H (k)	[-]	function of form
j	[-]	imaginary unit
K	[-]	stiffness matrix



k	[N/m]	stiffness
L_v	[dB]	surface noise level
\mathbf{M}	[-]	mass matrix
m	[-]	mass
$\mathbf{N}_p, \mathbf{N}_v$	[-]	matrix of interpolation functions
\mathbf{p}	[-]	column vector of pressure
s	[m]	displacement
S	[m ²]	area
s_{\max}	[m]	max. amplitude
t	[s]	time
T	[1/s]	period
\mathbf{U}	[-]	left singular matrix
v	[m/s]	velocity
\mathbf{V}	[-]	right singular matrix
\mathbf{v}_n	[-]	column vectors of normal velocity
y	[-]	vibration or acoustics unit
y_0	[-]	reference value of vibration or acoustics unit
α, β	[-]	Rayleigh damping coefficient
β_d	[deg]	angle of incidence
β_i	[deg]	angle of refracted
β_o	[deg]	angle of reflection
ζ	[-]	damping ratio
η	[-]	dynamic magnification factor
λ	[m]	wavelength
φ	[rad]	phase angle
Ω	[1/rad]	angular velocity