



# VYSOKÉ UČENÍ TECHNICKÉ V BRNĚ

BRNO UNIVERSITY OF TECHNOLOGY

## FAKULTA STAVEBNÍ

FACULTY OF CIVIL ENGINEERING

## ÚSTAV GEOTECHNIKY

INSTITUTE OF GEOTECHNICS

# GEOTECHNICAL SOLUTION OF FLOOD PROTECTION SYSTEM

GEOTECHNICKÉ ŘEŠENÍ PROTIPOVODŇOVÝCH OPATŘENÍ

## BAKALÁŘSKÁ PRÁCE

BACHELOR'S THESIS

## AUTOR PRÁCE

AUTHOR

Ján Krajčovič

## VEDOUCÍ PRÁCE

SUPERVISOR

Ing. VÁCLAV RAČANSKÝ, Ph.D.

BRNO 2017



# VYSOKÉ UČENÍ TECHNICKÉ V BRNĚ FAKULTA STAVEBNÍ

<b>Studijní program</b>	B3607 Stavební inženýrství
<b>Typ studijního programu</b>	Bakalářský studijní program s prezenční formou studia
<b>Studijní obor</b>	3647R013 Konstrukce a dopravní stavby
<b>Pracoviště</b>	Ústav geotechniky

## ZADÁNÍ BAKALÁŘSKÉ PRÁCE

<b>Student</b>	Ján Krajčovič
<b>Název</b>	Geotechnical solution of flood protection system
<b>Vedoucí práce</b>	Ing. Václav Račanský, Ph.D.
<b>Datum zadání</b>	30. 11. 2016
<b>Datum odevzdání</b>	26. 5. 2017

V Brně dne 30. 11. 2016

---

doc. Ing. Lumír Miča, Ph.D.

Vedoucí ústavu

---

prof. Ing. Rostislav Drochytka, CSc., MBA

Děkan Fakulty stavební VUT

## **PODKLADY A LITERATURA**

Podklady budou předány vedoucím bakalářské práce samostatně.

## **ZÁSADY PRO VYPRACOVÁNÍ**

Úkolem bakalářské práce je řešerše různých typů protipovodňových opatření, které se zhotovují technikami speciálního zakládání staveb. Součástí práce bude zjištění aktuálních normativních požadavků na zatížení protipovodňových konstrukcí. Praktická část práce bude zaměřena na návrh konstrukčního uspořádání protipovodňového opatření na modelové lokalitě.

## **STRUKTURA BAKALÁŘSKÉ PRÁCE**

VŠKP vypracujte a rozčleňte podle dále uvedené struktury:

1. Textová část VŠKP zpracovaná podle Směrnice rektora "Úprava, odevzdávání, zveřejňování a uchování vysokoškolských kvalifikačních prací" a Směrnice děkana "Úprava, odevzdávání, zveřejňování a uchování vysokoškolských kvalifikačních prací na FAST VUT" (povinná součást VŠKP).
2. Přílohy textové části VŠKP zpracované podle Směrnice rektora "Úprava, odevzdávání, zveřejňování a uchování vysokoškolských kvalifikačních prací" a Směrnice děkana "Úprava, odevzdávání, zveřejňování a uchování vysokoškolských kvalifikačních prací na FAST VUT" (nepovinná součást VŠKP v případě, že přílohy nejsou součástí textové části VŠKP, ale textovou část doplňují).

---

Ing. Václav Račanský, Ph.D.

Vedoucí bakalářské práce

## **ABSTRAKT**

Práca sa zaoberá problematikou protipovodňových hrádz a ich zlepšovania pomocou metód špeciálneho zakladania stavieb. Súčasťou práce je prehľad základných protipovodňových opatrení, súhrn normatívnych podmienok pre návrh a posúdenia odolnosti hrádze počas povodne. Praktická časť sa skladá s komplexného prehľadu možností ako zlepšiť protipovodňové opatrenia pomocou metód špeciálneho zakladania stavieb. Práca je ukončená konkrétnymi príkladmi z praxe.

## **KLÍČOVÁ SLOVA**

povodne, hrádze, podzemné tesniace steny

## **ABSTRACT**

Main target of work is problematic of flood protection systems and possibilities of improvement of them by methods of geotechnical solutions. Parts of work are overview of basic flood protection systems and resume of normative requirements for design of levee against flood. Practical part of work is composed from complex overview of geotechnics methods used for levee improvement. Work is ended by examples from practice.

## **KEYWORDS**

Floods, levees, Cut-off walls

## **BIBLIOGRAFICKÁ CITACE VŠKP**

Ján Krajčovič *Geotechnical solution of flood protection system*. Brno, 2017. 70 s.,  
Bakalářská práce. Vysoké učení technické v Brně, Fakulta stavební, Ústav geotechniky.  
Vedoucí práce Ing. Václav Račanský, Ph.D.

## **PROHLÁŠENÍ**

Prohlašuji, že jsem bakalářskou práci zpracoval(a) samostatně a že jsem uvedl(a)  
všechny použité informační zdroje.

V Brně dne 24. 5. 2017

---

Ján Krajčovič  
autor práce

## **POĎAKOVANIE**

Týmto by som chcel poďakovať všetkým ľuďom okolo seba. Ďakujem dr. Račanskému, za pomoc s výberom témy práce a poskytnuté podklady, dr. Chalmovskému za všetky konzultácie a nájdení čas a ing. Glisníkovej za môj zápal pre geotechniku. Ďakujem mojej rodine za neutíchajúcu podporu, mojím priateľom, ktorý ma udržovali v psychickom zdravý, a pánu Čolkovi za sprostredkovanie pravidelného pitného režimu.

# CONTENT

<b>1</b>	<b>INTRODUCTION.....</b>	<b>11</b>
1.1	FLOODS .....	11
1.2	HISTORY AND TARGET OF WORK .....	14
<b>2</b>	<b>FLOOD PROTECTION MEASURES.....</b>	<b>15</b>
2.1	FLOOD PROTECTION SYSTEMS.....	15
2.1.1	<i>Temporary</i> .....	15
2.1.2	<i>Demountable</i> .....	16
2.1.3	<i>Permanent</i> .....	16
2.2	PERMANENT WATER CONTROL STRUCTURES .....	17
2.2.1	<i>Floodplain improvements</i> .....	17
2.2.1.1	Relocation/Elevation of endangered structures.....	17
2.2.1.2	Flow diversion .....	17
2.2.1.3	Off-stream ponds .....	17
2.2.1.4	Floodwall/ Foundation protection dike.....	18
2.2.2	<i>Floodway improvements</i> .....	18
2.2.2.1	Reducing bank slope.....	18
2.2.2.2	Reinforcing bank .....	18
2.2.2.3	Bridge lower structure replacement.....	19
2.2.2.4	Levees setbacks .....	19
2.2.3	<i>Improvements of river channel</i> .....	19
2.2.3.1	Detention ponds.....	19
2.2.3.2	Sediment trap.....	20
2.2.3.3	Anchor logs .....	20
2.2.3.4	Deflector structures .....	20
2.2.3.5	Flow realignment.....	20
2.2.3.6	Chevron Dams .....	20
2.2.3.7	Gravel Bar Scalping .....	21
<b>3</b>	<b>LEVIES DESIGN AND REQUIREMENTS FOR FLOODS .....</b>	<b>22</b>
3.1	BASIC REQUIREMENTS .....	22
3.2	REQUIRED SAFETY LEVEL.....	22
3.2.1	<i>Hydrological resources</i> .....	22
3.2.1.1	Control flood wave (CFW).....	22
3.2.2	<i>Technological resources</i> .....	23
3.2.2.1	Geodetic resources .....	23
3.2.2.2	Resources about currently used water structures .....	23
3.2.2.3	Resources for newly designed water structures.....	23
3.2.2.4	Hydraulic calculations .....	24



3.3	DESIGN OF MAXIMAL CONTROL WATER LEVEL .....	24
3.3.1	<i>Initial level of CWL</i> .....	24
3.3.2	<i>Factors influencing high of CWL</i> .....	24
3.3.3	<i>Effects of wind waves</i> .....	25
3.3.4	<i>Stability assessment</i> .....	25
3.4	WATER LOAD FORCES ON LEVEES AND FLOOD RETENTION WALLS.....	26
3.4.1	<i>Hydrostatic pressure</i> .....	26
3.4.2	<i>Hydrodynamic pressure</i> .....	26
3.4.2.1	Pressure effects of flowing water .....	26
3.4.2.2	Friction force .....	28
3.4.2.3	Effects of translational waves.....	28
3.4.2.4	Cavitation effects.....	29
3.4.3	<i>Water Effects in pore environment</i> .....	29
3.4.3.1	Pore pressure.....	29
3.4.3.2	Change of pore pressure .....	30
3.4.3.3	Flow pattern .....	30
3.4.3.4	Buoying force determination .....	31
3.4.3.5	Effects of pore pressure on concrete structures.....	32
3.5	ICE LOADS AND EFFECTS ON RETENTION WALLS AND LEVEES.....	32
3.5.1	<i>General information</i> .....	32
3.5.1.1	Resources .....	32
3.5.1.2	Basic cases of load .....	32
3.5.2	<i>Loading from impact and friction of ice floes or ice field</i> .....	33
3.5.2.1	Force elements .....	33
3.5.2.2	Friction force .....	34
3.5.3	<i>Load of ice field drifted by wind and flow effects</i> .....	34
3.5.3.1	Ice field in contact with object .....	34
3.5.3.2	Determination of $p_{1,2,3,4}$ .....	35
3.6	SAFETY WATER LEVEL DESIGN.....	36
3.7	FINAL ASSESSMENT .....	36
<b>4</b>	<b>GEOTECHNICAL SOLUTIONS USED ON FLOOD PROTECTION MEASUREMENTS..</b>	<b>37</b>
4.1	UNDERGROUND WALLS .....	37
4.1.1	<i>Load-bearing walls</i> .....	37
4.1.1.1	Diaphragm walls.....	37
4.1.1.2	Secant pile wall .....	39
4.1.1.3	Sheet pile wall.....	40
4.1.1.4	Implant levees .....	41
4.1.2	<i>Cut-off walls</i> .....	42
4.1.2.1	Load bearing methods without reinforcement .....	43
4.1.2.2	Thin slurry walls .....	43

4.1.2.3	Soilcrete lamella wall.....	44
4.1.2.4	Deep soil mixing.....	45
4.1.2.5	Soil Mixing Wall.....	46
4.1.2.6	Cutter soil mixing wall .....	48
4.1.2.7	Trench cutting and Remixing Deep.....	49
4.1.2.8	Jet Grouting .....	50
<b>4.2</b>	<b>NON-WALL SOIL IMPROVEMENTS .....</b>	<b>52</b>
4.2.1.1	Cement grouting.....	52
4.2.1.2	Injection stabilization.....	53
<b>4.3</b>	<b>FLOODWALL FOUNDATIONS .....</b>	<b>55</b>
4.3.1	<i>Foundations of permanent floodwalls .....</i>	<i>55</i>
4.3.1.1	I-wall.....	55
4.3.1.2	T-wall .....	55
4.3.1.3	Steel sheet piles.....	56
4.3.1.4	Driven piles .....	56
4.3.2	<i>Foundations of demountable floodwalls.....</i>	<i>58</i>
<b>5</b>	<b>APPLICATION IN PRAX .....</b>	<b>59</b>
5.1	CUT-OFF WALLS (MORAVA RIVER, SLOVAKIA).....	59
5.2	SHEET PILE WALLS (VLTAVA RIVER, CZECH REPUBLIC).....	60
5.3	TRD WALL, (HOOVER DIKE, USA) .....	61
<b>6</b>	<b>CONCLUSION .....</b>	<b>62</b>
	<b>REFERENCES.....</b>	<b>63</b>
	<b>PICTURE LIST.....</b>	<b>68</b>
	<b>TABLE LIST.....</b>	<b>70</b>

# 1 INTRODUCTION

## 1.1 Floods

Over last decades, humanity is witnessing radical changes in global weather and phenomena accompanying it. We can observe not only huge increase of extremely hot days during a summer but also growth of wet, rainy days during a whole year. And it is only small step from rain to floods.

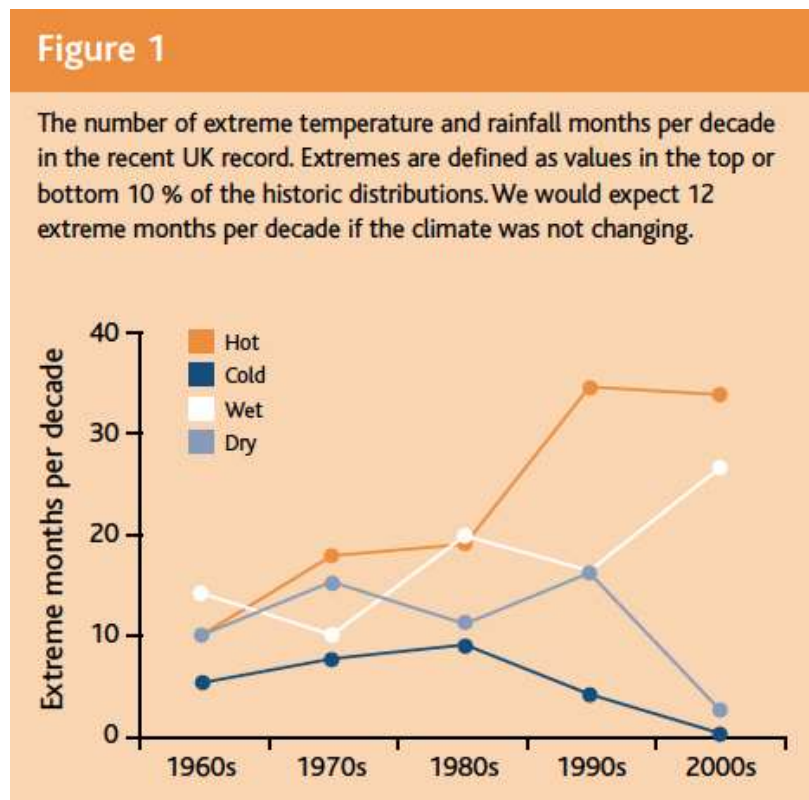


Figure 1.1 Extreme months in UK (12)

Floods are presenting biggest natural threat in most of European countries. Even though there is decreasing trend in human losses, numbers showing material damage are quickly rising. During last 40 years' material losses in terms of GDP went up by 200%! In

Spike years' damage is very often more than 1% GDP what is more than some countries invest in theirs's military.

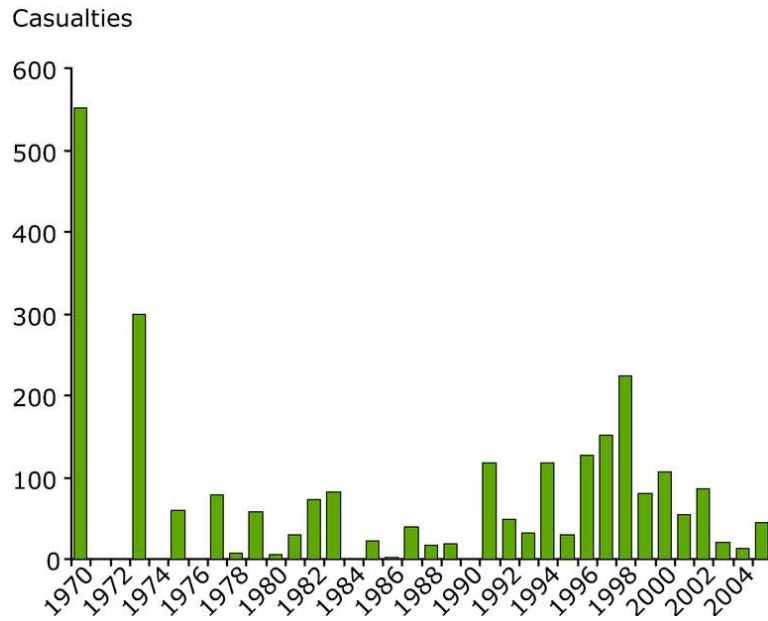


Figure 1.2 Casualties over European Union over last decades (13)

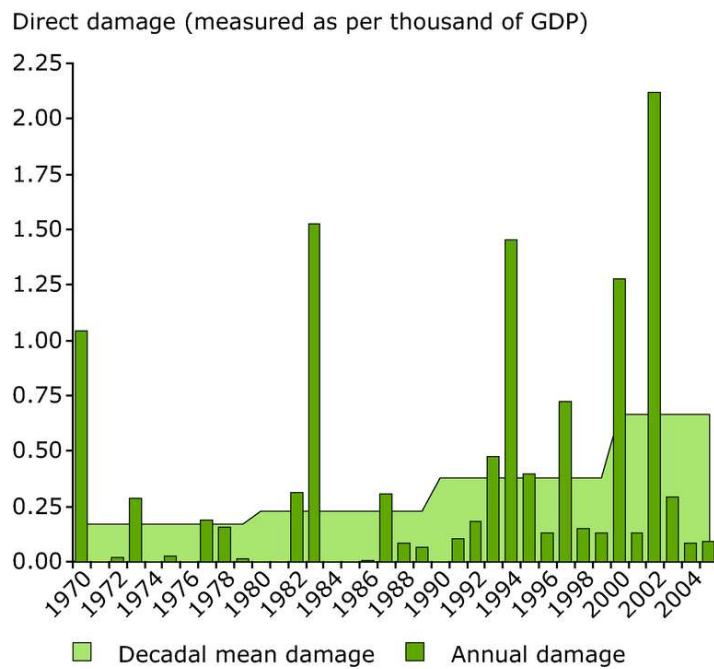
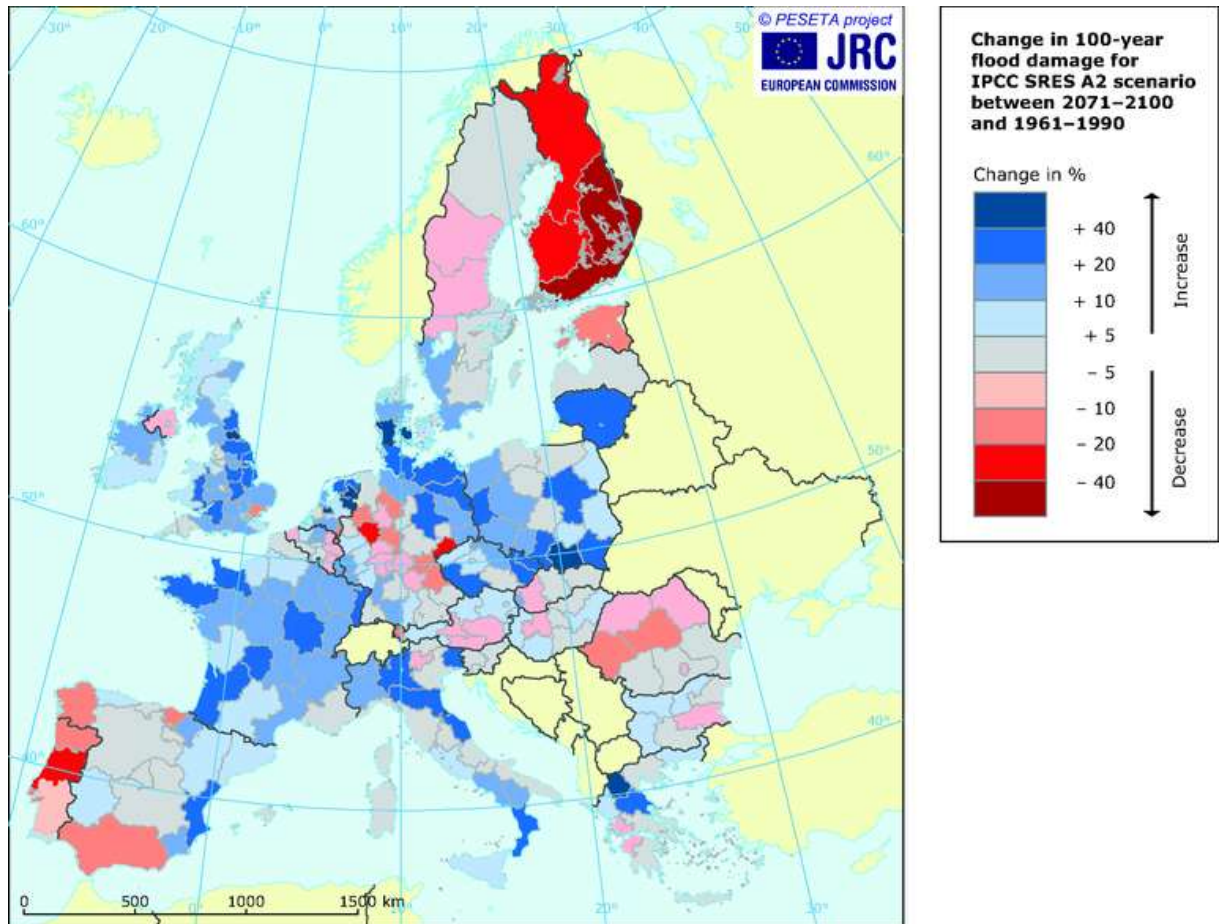


Figure 1.3 Direct damage over European Union over last decades (14)

As there is none prediction of any improvements in global climate over next years, prognosis for floods are not getting better neither. Studies and statistics are showing that we can expect 40% increase of flood damage in some parts of European union



**Figure 1.4 Predictions of flood damage in next 100 years (15)**

Thanks to painful experiences from last mayor flooding (1997,2002) and with not much positive predictions to the future, there were taken mayor actions. New laws and plans how to deal with critical flooding situations (Directive 2007/60/EC), but mainly these events caused large demand in building new flood protection constructions but also revitalization and reconstruction of older which cant fulfil its original purpose anymore.

## **1.2 History and Target of work**

First usage of artificial levees can be tracked back to first great civilization of bronze age, when they were constructed along with draining systems and wells. They were inspired by natural levees which were created by flooding sedimentation, as the flood water retreat to natural channel sediment levees along the shore are created. During whole human development of society and engineering, levees didn't develop nearly at all. Even in the early 20<sup>th</sup> century they were just mud and sand piled to the shape of trapezium.

Sadly, the 21<sup>st</sup> century showed that this won't be enough anymore, as mentioned before, events causing floods, heavy rains in Europe and hurricanes in USA, made most of current natural levees obsolete. New methods of construction of levees and another flood protection systems were needed. This work present list of most used methods in geotechnical engineering to improve old levees. (1)

## 2 FLOOD PROTECTION MEASURES

Flood protection measures should be understood not only as constructions, but also as wide portfolio of techniques to improve flood protection of endangered areas, including:

- Forecasting systems
- Flood alert systems and monitoring
- Development planning
- Construction of flood protection systems

### 2.1 Flood protection systems

Are constructions which prevent the floodwater from reaching the protected area. We can divide them into three main groups:

#### 2.1.1 Temporary

These systems consist from removable flood protection products which are installed during a flood event, and removed completely after lowering of water to safety level. As simplest and most common temporary protection system are considered sandbags.

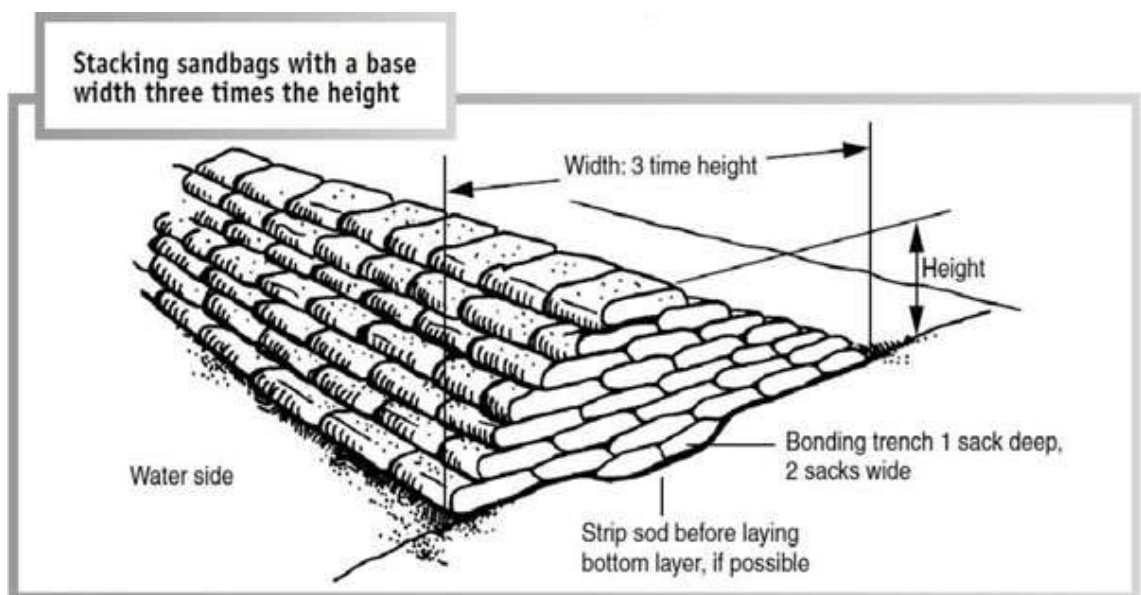


Figure 2.1 Temporary protection (18)

### 2.1.2 Demountable

Demountable protection systems are used instead or as extension of permanent protection measurements. In contrast to the temporary systems, they require pre-installation (foundations) in protected area, but to contrast with permanent system they are elevated to full level only during floods.

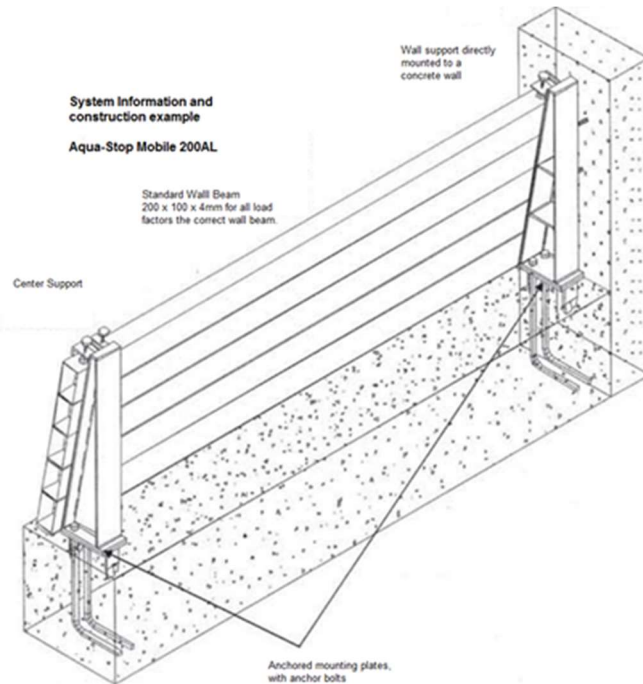


Figure 2.2 Demountable protection system (20)

### 2.1.3 Permanent

Measurements which are fully placed for their own lifespan and without need to any operation are called permanent protections systems. These are not including just physical barriers against floodwater but they are represented as changes and improvements of floodplain, floodway and river channel itself.

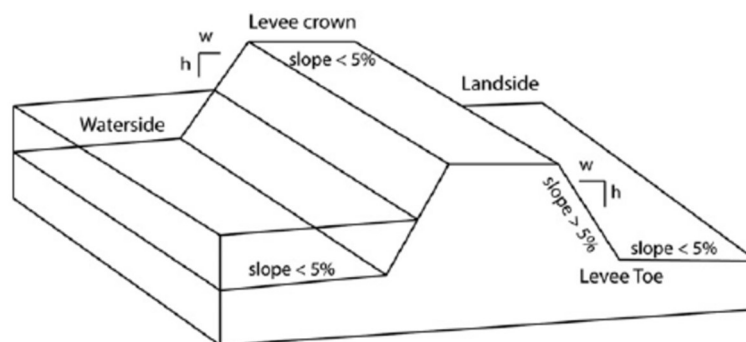


Figure 2.3 Permanent protection system (17)



## 2.2 Permanent water control structures

As previously mentioned we can divide them into three main groups

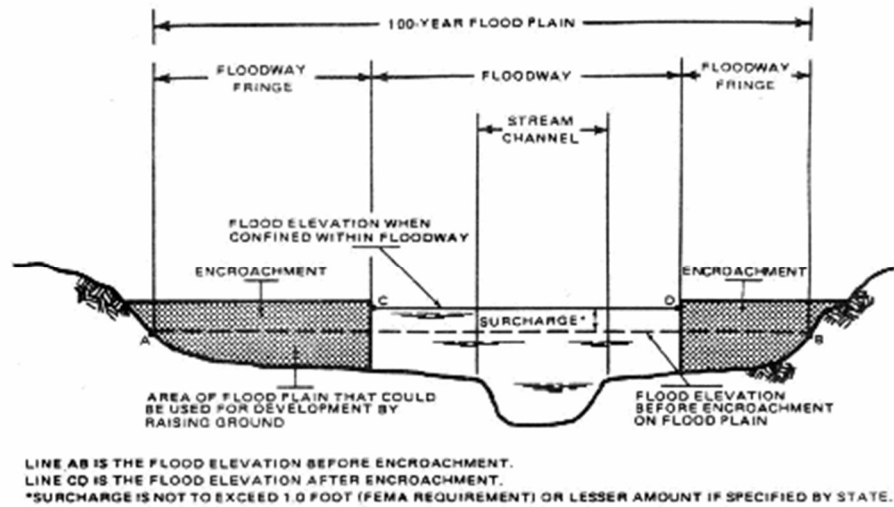


Figure 2.4 River cross-section division (19)

### 2.2.1 Floodplain improvements

Floodplain includes all land which is at or under the water level of 100-year flood of nearby river.

#### 2.2.1.1 Relocation/Elevation of endangered structures

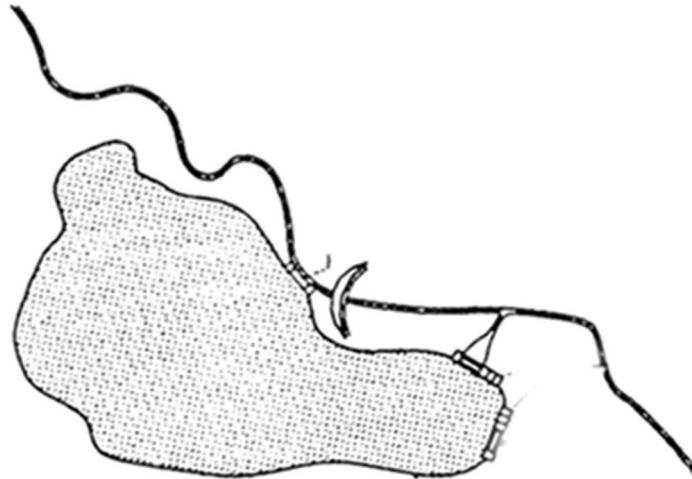
This solution is extremely expensive and many times event not possible as many structures can't be just relocated and also due to loose of agricultural land.

#### 2.2.1.2 Flow diversion

By diverting flow of river to less loaded or newly built channels we reduce both normal and 100-year (flood) water level.

#### 2.2.1.3 Off-stream ponds

With insufficient capacity of main flow during floods we can also diver water part of water to the off-stream ponds. Detention ponds built over a level of surrounding terrain many times require same design approach as levees for structure protection (see next)/ channelling improvements (see water channelling).



**Figure 2.5 Off-stream pond (16)**

#### **2.2.1.4 Floodwall/ Foundation protection dike**

Structures designed for direct protection of selected object from flood water. These measurements require special design approaches with usage of Geotechnics. Either foundations of floodwall (permanent but also demountable) or whole construction design of dike from soils.

### **2.2.2 Floodway improvements**

Floodway is defined as river channel and river banks which reach full level during floods.

#### **2.2.2.1 Reducing bank slope**

By changes to bank slope we are increasing flow of water in the bank by increasing flow profile. Lowered erosion of banks slopes is another positive effect of this ground work.

#### **2.2.2.2 Reinforcing bank**

With adding stabilisation material to river bank, we can increase its resistance to scour. Reinforcing can be done by many ways:

- Bioengineering

- Gabions
- Concrete mattresses
- Geotextiles & geogrids

#### *2.2.2.3 Bridge lower structure replacement*

Lower structure of bridge many time obstruct the river flow, mainly during a floods, what causes increased water level at these places. By increasing width between piers, we can reduce significantly water level during floods.

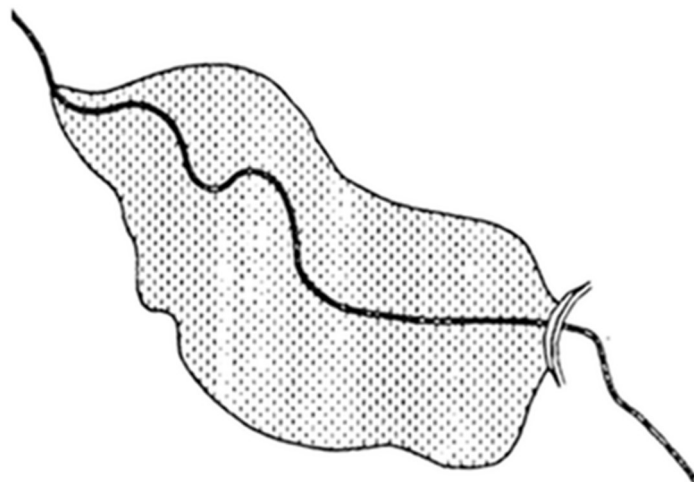
#### *2.2.2.4 Levees setbacks*

Moving of levees more away from floodway to floodplain we are allowing river to meander more naturally. This solution also increase river ability to carry larger volumes of water during flood events

### **2.2.3 Improvements of river channel**

#### *2.2.3.1 Detention ponds*

Compared to off-stream ponds, detention ponds are built directly on river channel. These ponds are created by building weir or dam across the river. Their role is retain larger amount of floods water upstream, and by controlled releasing, regulate downstream level of water to prevent floods.



**Figure 2.6 Detention pond (16)**

#### 2.2.3.2 *Sediment trap*

Traps are depression excavated in the bottom of river. Their purpose is collect sediments contained in the flood waters. Placing of these systems should be carefully calculated as they must be mined again after every major flood.

#### 2.2.3.3 *Anchor logs*

Placing anchored logs on the sides of river channel will have same results as reinforcing banks of floodway. They will reduce erosion and meandering of river channel.

#### 2.2.3.4 *Deflector structures*

By usage of vanes and dikes for deflection of flood stream we reroute or contain water flow in desired direction.

Dikes purpose is extend river bank to river channel by simple extension of maximal water level.

Vanes are constructed from metal (demountable system) or concrete (permanent system) plates which are anchored by piles to the surrounding terrain or levees/dikes.

#### 2.2.3.5 *Flow realignment*

This solution involves creating new, deeper channel in the river bottom, which have different alignment than previous channel. New channel with improved water conveyance can significantly reduce frequency and severity of flooding.

#### 2.2.3.6 *Chevron Dams*

V-shaped, low height weir built across a river channel. Tip of V is pointing downstream, slop is decreasing from end of arms to tip, which result in diverting flow to the middle of the channel. This system doesn't impact flood in term of water flow, but prevent erosion of banks.

#### 2.2.3.7 *Gravel Bar Scalping*

Excavation of coarse material in upper layers of gravel bars in the braided river channels will likely increase volume of channel. This will result in less frequent and shorter floods. (2)

### 3 LEVIES DESIGN AND REQUIREMENTS FOR FLOODS

#### 3.1 Basic requirements

Safety analysis of water constructions during floods is based on three main factors. The required safety level of construction  $p$ , Maximal Control water level (CWL) and the Limit safety water level (SWL).

#### 3.2 Required safety level

Safety level is calculated and categorized by the importance of water structure from the point of possible damage output if the catastrophic outcome will happen.

**Table 3.1 Required safety for design and assessment of water structure (3)**

Category of water structure	Plausible damage output in case of hypothetical collapse of water structure	Evaluation factors depending on potential damage outcome in case of hypothetical collapse of water structure		Required safety level of water structure	
		Potential total damage	Hypothetic loses of human lives	$p= 1/N$	N (years)
I.	very high	extremely high economic loses, environmental loses and social impact on state level	expectancy of live loses	0,0001	10 000
II.	high	high economic loses, environmental loses and social impact on region or state level	expectancy of live loses	0,0001	10 000
			unlikely loses of lives	0,0005	2 000
III.	medium	significant economic loses, environmental loses and social impact on region level	expectancy of live loses	0,001	1 000
			unlikely loses of lives	0,005	200
IV.	low	small economic loses, environmental loses and social impact on local level	exceptional loses of lives	0,005	200
			unlikely loses of lives	0,01	100
		small economic loses for ow ner of WS, other loses are insignificant	unlikely loses of lives	0,05	20

#### 3.2.1 Hydrological resources

##### 3.2.1.1 Control flood wave (CFW)

CFW is normally defined as theoretical N-year flood wave. If seasonal distribution of floods is occurring in analysed area, seasonal variants of CFW are required.

CFW should be determined by best currently available methods. For I. and II. category are required at least two independent methods.

### **3.2.2 Technological resources**

#### *3.2.2.1 Geodetic resources*

- Map resources and information about land around and under water structure
- Situation of water structure in scale from 1:100 to 1:1 000, with all surrounding objects, which can affect flood distribution
- Longitudinal profile of analyzed object with surrounding area, where is object founded.
- Characteristic cross-sections
- Information about measurements which are helping with management of floods.

#### *3.2.2.2 Resources about currently used water structures*

Resources provided by owner of structure

- Actualised documentation of real state of water structure, with list of all changes done on the structure
- Equipment of water structure for flood situations
- Last analysis of flood safety of water structure
- Actual manipulation order and placement of structure in the water management system

Resources provided by own research

- Resistance of structure against overflow
- Factors influencing safety of structure during floods
- Information about foundation, hydrogeological research
- Results of stability analysis
- Results of hydrotechnical research

#### *3.2.2.3 Resources for newly designed water structures*

- Project documentation of analysed structure (with results of geotechnical, hydrogeological and water management research) Hydrologic research older than 5 years must be checked.
- Inspection basin of upper flow for all water structures of category IV., for comparison of hydrological documentation and real situation. For other structures is recognition done by individual needs.

- Inspection of areas under the water structure and usage of available information/ studies about flood protection in inspected area.
- Analysis of water flow capability under the water structure

#### 3.2.2.4 *Hydraulic calculations*

- Specific flow curves are calculated for every part of water structure which can to churn flood water. Stability and capacity should be calculated for all parts of structure and for all types of water flow
- All calculation should be sustained by description of calculated method
- Correctness of all flow curves taken from documentation must controlled

### **3.3 Design of maximal control water level**

CWL is specified for exact type and design solution of structure, as maximal water level in dam, which can cause damage to the structure and collapse of water structure.

#### **3.3.1 *Initial level of CWL***

Is determined from specific design of structure, its insulation and conditions specific for analysed structure. If water work is already in use, experiences from usage and from safety controls should be considered. (3)

Most often causes of collapse of structure are

- Surface erosion during overflow
- Damage to filtration stability of dam or subsoil
- Deformation along shear plain (exceeding of Deformation limit state)
- Tilt of the structure (exceeding limit state of stability)

#### **3.3.2 *Factors influencing high of CWL***

- Type, age and state of levee/dam
- Foundation conditions and foundation form, filtration mode
- Engineer geological properties of soils and rocks used for construction



- Protection of sealing element against damage and freezing, and his connection to impermeable subsoil
- Construction solution of sewer dam, its connection to concrete structures and its high placement in terms of bypassing or overflowing
- Longitudinal profile, equipment and protection of dam crest, its protection against overflow
- Construction of groyne or wall on the top of crest
- Length, slope, and protection of air face of dam/levee
- Location, shape and dimensions of object on air face of dam
- State and shape of intersection between levee and other earthworks on air face
- Expected settlement
- Effects of air wind wave

### 3.3.3 *Effects of wind waves*

For waterworks included in groups from I. to III., decrease or increase of water level must calculate by using ČSN 75 0255

For waterworks categorized as IV., where wave-run length (distance between levee and opposite shore) isn't more than 300 m, table 3.2 can be used for height calculation.

**Table 3.2 Orientation values of runup (3)**

Type of water-face protection	Effective length of water-run (m)	Wave runup (m) for design speed of 72 km/h	
		Slope of water-face of levee	
		1:3	1:2
rough surface (stone packing, vegetation cover)	≤ 100	0,33	0,42
	101 to 200	0,43	0,54
	201 to 300	0,5	0,64
smooth surface (bitumen concrete, pavement)	≤ 100	0,42	0,53
	101 to 200	0,54	0,67
	201 to 300	0,62	0,8

### 3.3.4 *Stability assessment*

After value of CWL is set up, stability assessment of construction must be done. If required safety level is not achieved, lower complying level of CWL is calculate by iteration. For stability calculation, forces acting on construction must be calculated.

## 3.4 Water load forces on levees and flood retention walls

### 3.4.1 Hydrostatic pressure

Hydrostatic pressure is linearly growing with water depth, in depth  $z$  under calm surface is characteristic value determined as:

$$p_{hs,k} = \gamma_w \cdot z \quad (3.1)$$

where

$\gamma_w$  Specific weight of water

Hydrostatic pressure is perpendicular to surface of construction loaded by water.

### 3.4.2 Hydrodynamic pressure

#### 3.4.2.1 Pressure effects of flowing water

Pressure force of free water ray impacting perpendicular on non-overflowed immobile solid plate

$$F_R = \rho_w \cdot S_p \cdot v^2 = \rho_w \cdot Q \cdot v \quad (3.2)$$

Pressure force of free water ray impacting under angle  $\alpha$  on non-overflowed immobile solid plate

$$F_R = \rho_w \cdot S_p \cdot v^2 \cdot \sin^2 \alpha = \rho_w \cdot Q \cdot v \cdot \sin^2 \alpha \quad (3.3)$$

Where

$\rho_w$  Volume weight of water ( $\text{kg}\cdot\text{m}^{-3}$ );

$S_p$  Surface area of water ray cross-section ( $\text{m}^2$ );

$v$  Flow speed ( $\text{m}\cdot\text{s}^{-1}$ );

$Q$  Discharge ( $\text{m}^3\cdot\text{s}^{-1}$ );

$\alpha$  angle between construction and water flow ray;

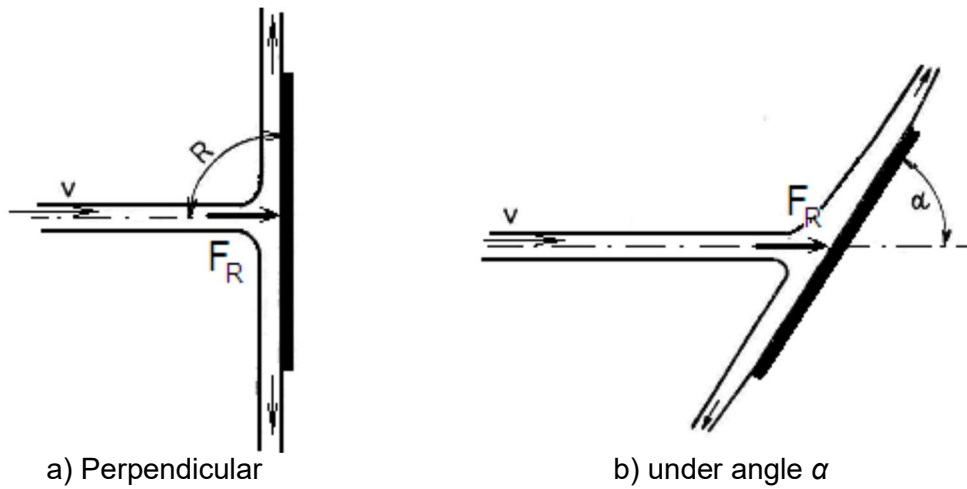


Figure 3.3.1 Scheme of water ray impaction on construction (4)

Increase of pressure due to flow inside curve is represented by pressure force  $F_c$  from effects of centrifugal force.

Force  $F_c$  is acting in direction of centre angle of arc and is define for channel of width  $W_1$  or  $W_2$  and for speeds  $v_1$  and  $v_2$ .

$$F_c = \rho_w \cdot Q \cdot (v_1^2 + v_2^2 - 2 \cdot v_1 \cdot v_2 \cdot \cos \alpha) / 2 \quad (3.4)$$

If  $W_1 = W_2$  and so  $v_1 = v_2$ , force will be calculated by simplified equation

$$F_c = 2 \cdot \rho_w \cdot v_2^2 \cdot S \cdot \sin \alpha / 2 \quad (3.5)$$

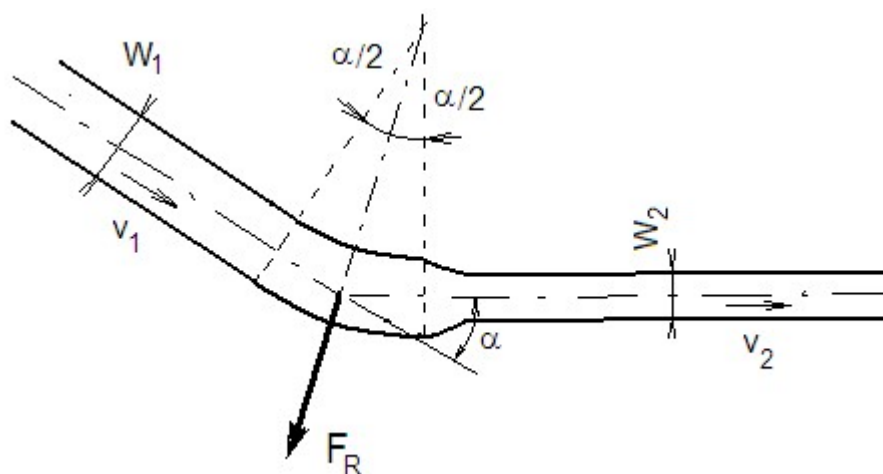


Figure 3.3.2 Scheme of resultant from centrifugal force (4)

### 3.4.2.2 Friction force

On wet sides of water channel flow of water is creating friction force from friction movement against wall.

In open channels this force is calculated as

$$F_t = \tau_0 \cdot O \cdot L \quad (3.6)$$

$\tau_0$  Tangential stress acting on unit of wet area (Pa, kPa);

$O$  Wet circuit of flow profile (m);

$L$  Length of calculated part of channel (m).

If average flow speed is used for calculation,  $\tau_0$  is calculated as

$$\tau_0 = \rho_w \cdot g \cdot R \cdot i_0 \quad (3.7)$$

$R$  hydraulic radius (m);

$i_0$  longitudinal slope of channel (-).

$R = h$  for wide channels

### 3.4.2.3 Effects of translational waves

For shock waves in open channels, load of construction is suddenly changing during impact of front of wave on construction. After impact, water level is changing slowly, depending on increase or decrease of wave.

For impact of wave on flat or even sloped wall, deformation of wave “splashing,” must be also considered.

For short distances, change of flow due to advance of shock wave is considered constant.

On longer distances, change of advance of shock wave must be considered, due to losses created by friction or change of slope of bottom of channel.

Force effects of shock waves should be considered also on parallel constructions, as shores improvements.

Change of advance of wave means, that change of flow volume and of flow speed too is changing as the wave advance over distance. For complicated and important structures is recommended determine height of wave by experiments.

#### 3.4.2.4 Cavitation effects

Cavitation effects are formed in curves or brakes of flow, due to high flow speed. These effects can create disruption of material and oscillation of constructions.

To prevent effect of cavitation, cavitation coefficient  $\varepsilon_k$  should be less than 0,5 to 1,0. For well-maintained surfaces with good hydraulic properties is  $\varepsilon_k$  considered 0,5.  $\varepsilon_k=1,0$  should be used for all cases when sufficient flow current isn't anticipated.

$$\varepsilon_k = 2g \cdot (p_{st} - p_{vp}) / (\gamma_w \cdot v^2) \quad (3.8)$$

$p_{st}$  total static water pressure (Pa, kPa);

$p_{vp}$  pressure of water vapours (Pa, kPa);

$v$  flow speed in inspected place ( $m \cdot s^{-1}$ ).

If speed distribution through cross-section is unequal, or for other complicated cases of flow, critical cavitation coefficient must be determined by hydrotechnical research.

### 3.4.3 Water Effects in pore environment

#### 3.4.3.1 Pore pressure

During volume change of pores, caused by change of tension or infiltration of water, tension (pore tension  $p_u$ ) between water and air is created. Pore pressure is determined in every point of pore environment by pressure (piezometric)  $h_{pm}$  height and its value is calculated as

$$p_u = \rho_w \cdot g \cdot h_{pm} \quad (3.9)$$

$p_u$  pore pressure (kPa);

$h_{pm}$  piezometric height (m).

### 3.4.3.2 *Change of pore pressure*

Size and effects of pore pressure after change of construction or it's subsoil are considered when:

- It increases of stresses in subsoil and in construction during building phase
- Is changing tension in subsoil or construction, during water level decrease/increase
- Is changing tension in consolidated soil or rock, during pressure relief or during dig works

Way of determination of pore pressure formed during construction works on levee and subsoil, should consider properties of soils, construction methods and height of levee.

If levee height is more than 15m or also for lower levees built from soils with low permeability and not optimal humidity or subsoils of low permeability or for dams of high importance, filtration or more accurate methods should be used.

In other cases, pore pressure can be calculated by more simply methods as for example with coefficient of pore pressure

### 3.4.3.3 *Flow patern*

Water infiltrating through pore medium is creating flow pattern, which is illustrated by flow net. Effects of pressure from infiltrating water can be expressed by two methods.

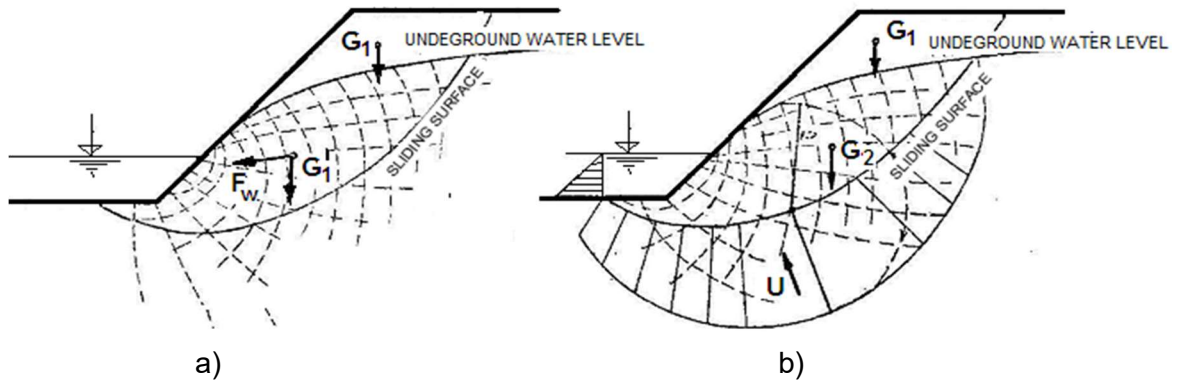
- a) If pressure force of infiltrating water is considered for evaluation of stability, force acting in direction of flow on unit of volume of pore medium is calculated as

$$p_u = i \cdot \rho_w \cdot g \quad (3.10)$$

$I$  slope of pressure line determined as difference of piezometric heights for unit of length.

Stability of construction is evaluated with influence of total force resultant of infiltrating water and effective unit weight of calculated medium. (see picture 3.3a)

- b) If pore pressure of infiltrating water is used for determination of construction buoying force  $U$ , values of pore pressure on the edge of evaluated area are calculated by equation (3.9) (see picture 3.3b)



**Figure 3.3 Scheme of pressure net (4)**

NOTE Pore pressure size after quick decrease of water level should be for case a) is determined experimentally. For case b) pore pressure can be obtained with help of coefficient  $\gamma_{ru}$ . In this case sudden water level drop must be evaluated for most critical water level.

#### 3.4.3.4 Buoying force determination

For determination of buoying force, which is lifting construction based on permeable soil we can assume:

- Infiltration speed is proportional to piezometric slope (Darcy law)
- Permeability of infiltrated subsoil is constant in time
- Normally space flow in subsoil, with enough accuracy, can be substitute by plane flow (except cases, when differences of anisotropy between area of calculation and other direction are very different).

#### *3.4.3.5 Effects of pore pressure on concrete structures*

If effects of pore pressure during constant flow or for sudden drop of water level are considered for calculation. Pore pressure for constructions with cavities is determined from flow net. For solid concrete construction, loaded by hydrostatic force, linear trajectory of piezometric line between opposite faces of construction can be expected. On water side is allowed reduce value of piezometric force by 10% of difference between hydrostatic pressures. Reduction can't be used for cases of working joints and cracks.

### **3.5 Ice loads and effects on retention walls and levees**

#### **3.5.1 General information**

##### *3.5.1.1 Resources*

Default resources for calculation of ice load is information about climatic conditions in location of construction.

##### *3.5.1.2 Basic cases of load*

For calculation of forces caused by ice load, these load types should be considered

- a) Ice cover load from temperature increase
- b) Load from ice cover freeze to construction during water level change
- c) Load of pillars from cutting of ice field
- d) Load on construction from ice field drifted by effects of wind or water flow
- e) Load by ice jam or frazil-ice jam

In case of floods, only loading case c) is considered for calculations.



### 3.5.2 Loading from impact and friction of ice floes or ice field

#### 3.5.2.1 Force elements

Perpendicular force element of characteristic force  $F_3$  (kN) acting on vertical wall from individually floating ice floes under angle  $\delta$  can be calculated as

$$F_{3r} = \gamma_j \cdot v_1 \cdot h \cdot (A_i \cdot f_{ic})^{-1} \cdot \sin \delta \quad (3.11)$$

Parallel force element is calculated by equation

$$F_{3t} = F_{3r} \cdot f \quad (3.12)$$

Perpendicular force acting on unit of length of vertical wall shouldn't be bigger than

$$F_{3r,lim} = f_{ic} \cdot h \cdot k_s \quad (3.13)$$

Where

$\gamma_j$  coefficient depending on type of obstruction. For individual pillars  $\gamma_j = 1,35$ , for walls  $\gamma_j = 2,20$

$v_1$  movement velocity of floe (m/s), usually it is from 1,1 to 1,3 bigger than water velocity on surface and drops with depth and diminishing surface of ice floe;

$h$  ice thickness of floe (m);

$A_i$  surface are of ice floe (m<sup>2</sup>)

$f_{ic}$  strength of ice in crushing (kN/m<sup>2</sup>). If accurate experimental resources are not available, characteristic value for ice strength is considered  $f_{ic,k} = 750$  kN/m<sup>2</sup>. For maximal water level during ice flow,  $f_{ic,k} = 450$  kN/m<sup>2</sup>

$\delta$  angle between wall and flow direction

$f$  friction coefficient between ice floe and object, for concrete  $f = 0,11$ , for stone facing  $f = 0,14$

$k_s$  coefficient of imperfect impact of whole surface of ice floe, for initial stadium  $k_s = 0,6$  and for maximal water level  $k_s = 0,8$

### 3.5.2.2 Friction force

Characteristic value of load force  $F_f$  (kN) created by friction of ice field along the walls of construction, acting on construction surface and in direction of flow, can be calculated as

$$F_f = F_{3r,lim} \cdot f \quad (3.13)$$

### 3.5.3 Load of ice field drifted by wind and flow effects

#### 3.5.3.1 Ice field in contact with object

Characteristic value of load from static ice field, which is in contact with an object and is acting on surface of structure by force  $F_5$  (kN) due to water flow and wind actions, is calculated as (4)

$$F_5 = (p_1 + p_2 + p_3) \cdot A_{if} + p_4 \cdot A_{if} \quad (3.14)$$

Where

$P_1$  intensity of force from flow friction to bottom surface of ice field, calculated on unit of area of ice field (kN/m<sup>2</sup>);

$P_2$  element of unit weight of ice field parallel with water surface and it's slope, calculated on unit of area of ice field (kN/m<sup>2</sup>);

$P_3$  intensity of force from friction between air and upper surface of ice field, calculated on unit of area of ice field (kN/m<sup>2</sup>);

$P_4$  intensity of force from hydrodynamic pressure, caused by flow on face of ice field, calculated on unit of area of face of ice field (kN/m<sup>2</sup>);

$A_{if}$  surface area of ice field (m<sup>2</sup>);

$A_{if}$  surface area of face of ice field (m<sup>2</sup>);

### 3.5.3.2 Determination of $p_{1,2,3,4}$

$$p_1 = k_1 \cdot v_w \quad (3.15)$$

$$p_2 = k_2 \cdot \rho \quad (3.16)$$

$$p_3 = k_3 \cdot v_b \quad (3.17)$$

$$p_4 = k_4 \cdot v_w \quad (3.18)$$

where

$k_1$  coefficient of friction between flowing water and ice,  $k_1 = 5 \cdot 10^{-3}$  for continuous ice field and  $k_2 = 20 \cdot 10^{-3}$  for cumulation of frazil-ice jam (this situation can occur for under river channel in which frazil ice is created);

$k_2$  coefficient of inhomogeneity of ice. For ice cover is considered value  $k_2 = 1,0$ ; for ice field from floes  $k_2 = 0,9$ ; for frazil-ice jam  $k_2 = 0,8$ ;

$k_3$  coefficient of friction between air and ice, considered as  $k_3 = 5 \cdot 10^{-5}$ ;

$k_4$  coefficient of hydrodynamic water pressure, considered as  $k_4 = 0,50$ ;

$v_w$  velocity of water stream under ice (m/s). If characteristic value of stream velocity can be based of statistic methods, it is considered as 0,98 quantiles of maximal year velocity of stream;

$v_b$  maximal wind velocity (m/s) in period of ice movement. It is determined by meteorological data, if they are not available,  $v_b = 20-30$  m/s, depending on cover of water surface again wind;

$h_f$  thickness of ice field (m). If characteristic value of ice field thickness can be based of statistic methods, it is considered as 0,98 quantiles of maximal year ice thickness;

$\rho_i$  volume weight of ice. Value for crystal ice is ordinary  $9200$  kg/m<sup>3</sup>

$i$  slope of water surface

### 3.6 Safety water level design

SWL for floods is set up by solving task of transformation of flood wave by retention effects of dam/levee. If hydrological resources propose more variations of Control flood wave, task is solved multiple times.

For water works of class from I. to III., retention effect must be quantified. Neglection must be justified. For every water work of class IV., is approach individual, depending if water work is safe event without retention effect or not.

Initial water level is assumed according of manipulation order and experiences with real usage.

### 3.7 Final assessment

Result of assessment is relation between SWL and CWL with assessment of these aspects:

- a) Importance of water work and risk of endangerment of are under it.
- b) Accuracy and reliability of hydrological resources
- c) Accuracy of transformation of control flood wave
- d) Quantification and evaluation of reserves of water work during guidance of flood

Water work is generally safe when **CWL < SWL** (3)

(3.19)

## 4 GEOTECHNICAL SOLUTIONS USED ON FLOOD PROTECTION MEASUREMENTS

### 4.1 Underground walls

Underground walls used for improvement of levees can be divided by their role in to the two main groups

- 1) Walls with load-bearing and insulation functions
- 2) Cut-off walls - Insulation function only

Note: Walls using bentonite or concrete are called Slurry walls

#### 4.1.1 Load-bearing walls

Are structure used to retain soil, rock or other materials in a vertical condition. Hence they provide a lateral support to vertical slopes of soil that would otherwise collapse into a more natural shape.

Basic versions of load-bearing walls are:

- Diaphragm (Reinforced concrete) walls
- Secant Pile walls
- Sheet pile walls

##### 4.1.1.1 Diaphragm walls

Diaphragm walls are concrete or reinforced concrete walls constructed in slurry-supported, open trenches below existing ground. Concrete is placed using the Tremie installation method or by installing pre-cast concrete panels (known as a pre-cast diaphragm wall). Diaphragm walls can be constructed to depths of 100 meters and to widths of 0.45 to 1.50 meters.



**Figure 4.1 Work on diaphragm wall used for levee improvement (21)**

Diaphragm wall construction methods are relatively quiet and cause little or no vibration. Therefore, they are especially suitable for civil engineering projects in densely-populated inner city areas.

Due to their ability to keep deformation low and provide low water permeability, diaphragm walls are also used to retain excavation pits in the direct vicinity of existing structures.

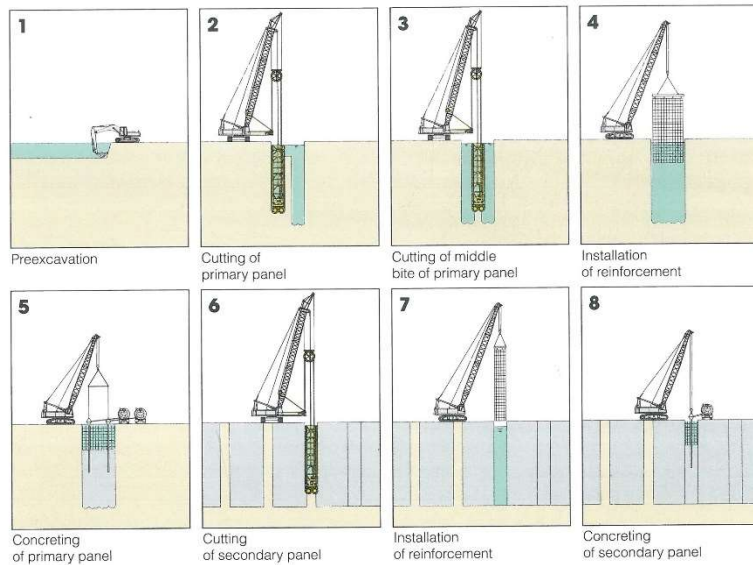
If there is a deep excavation pit at the edge of an existing structure and groundwater is present, diaphragm walls are often used as the most technically and economically favourable option. They can be used for temporary support or as load-bearing elements of the final building. Diaphragm walls can be combined with any anchor and bracing system.

Diaphragm wall panels are also used in deep, load-bearing soil layers as foundation elements to carry concentrated structural load in the same way as large drilled piles do.

(5)

#### Excavation methods

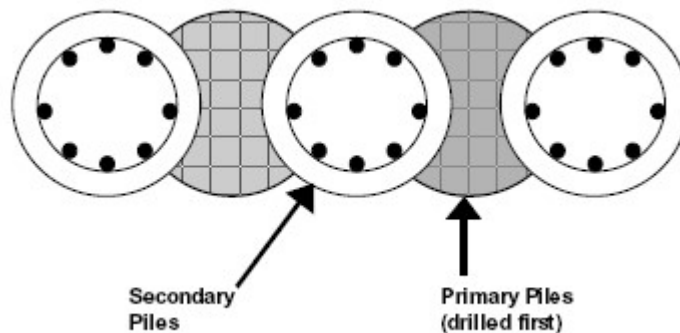
- Rope grabs – soft soil environment
- Hydro-cutter – rock & soil environment



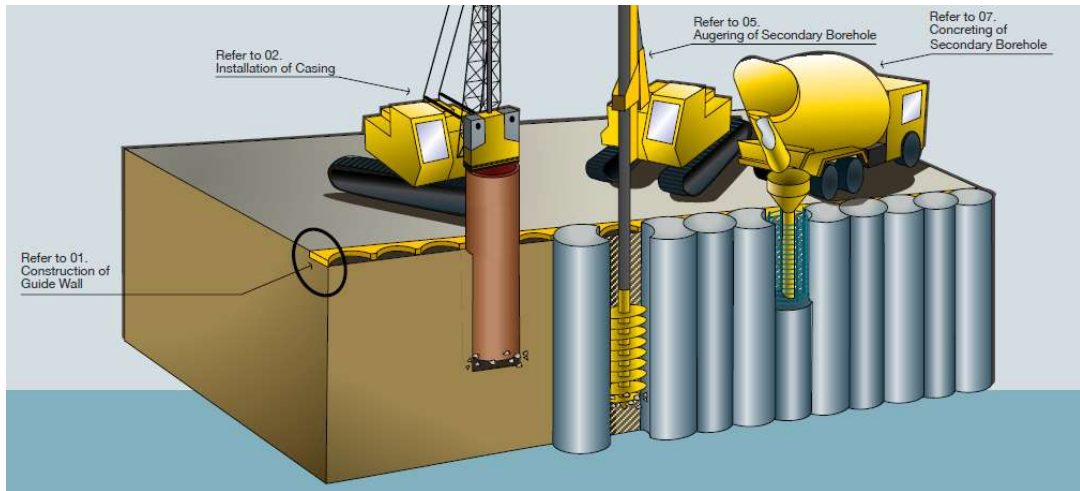
**Figure 4.2 Construction steps of diaphragm wall (23)**

#### 4.1.1.2 Secant pile wall

Secant pile walls are formed by constructing intersecting reinforced concrete piles. The secant piles are reinforced with either steel rebar or with steel beams and are constructed by either drilling under mud or augering. Primary piles are installed first with secondary (male) piles constructed in between primary (female) piles once the latter gain sufficient strength. Pile overlap is typically in the order of 3 inches (8 cm). In a tangent pile wall, there is no pile overlap as the piles are constructed flush to each other.



**Figure 4.3 Secant pile wall cross-section (22)**



**Figure 4.4 Construction of secant pile wall (22)**

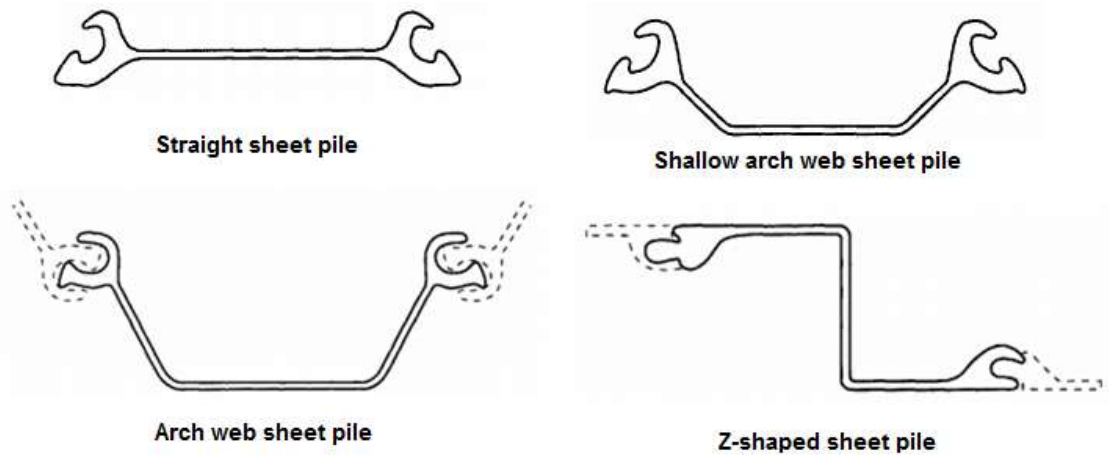
#### **4.1.1.3 Sheet pile wall**

Sheet pile walls are constructed by driving prefabricated sections into the ground. Soil conditions may allow for the sections to be vibrated into ground instead of it being hammer driven. The full wall is formed by connecting the joints of adjacent sheet pile sections in sequential installation. Sheet pile walls provide structural resistance by utilizing the full section. Steel sheet piles are most commonly used in deep excavations, although reinforced concrete sheet piles have also been used successfully.



**Figure 4.5 Steel Sheet pile wall construction (24)**

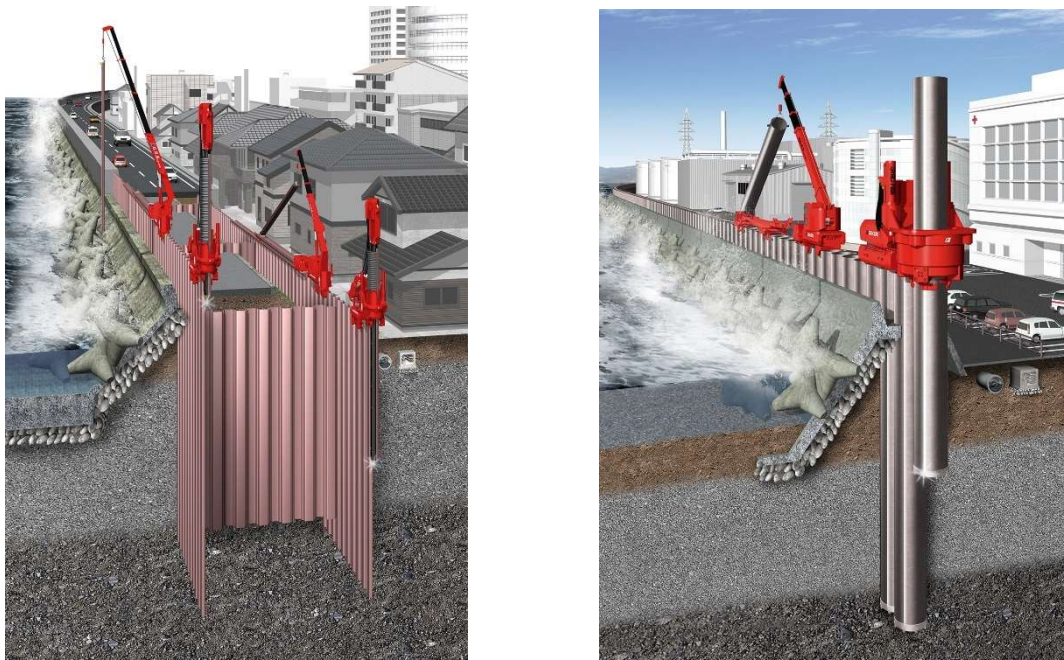




**Figure 4.6 Common shapes of steel sheet piles**

**4.1.1.4 Implant levees**

An implant levee is solid and strong against complex disasters such as earthquakes, tsunami and land subsidence. It is created either from steel sheet piles or tubular steel piles (6)



**Figure 4.7 Implant levees (25)**

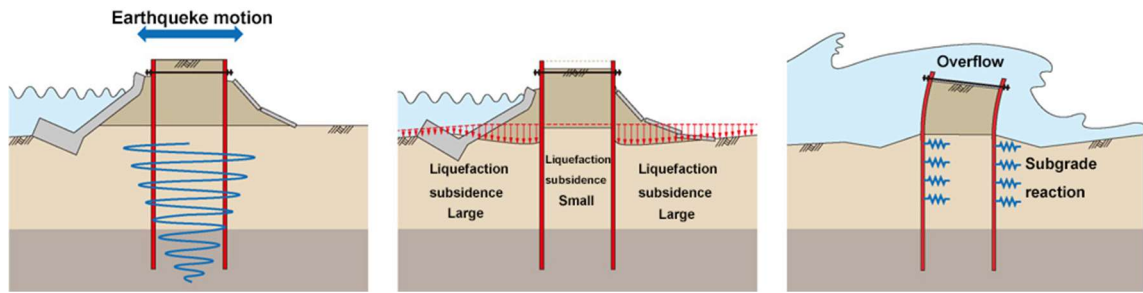


Figure 4.8 Resistance of implant levees (26)

#### 4.1.2 Cut-off walls

Cut-off walls are vertical slurry walls with very low water permeability to minimize the ground water flow.

In contrast to the known load-bearing, cut-off walls are mostly without any load-bearing function. (5)

Most common types of cut-off walls are:

- Secant Pile walls -plain (see above)
- Sheet pile walls (see above)
- Diaphragm walls from plain concrete (see above)
- Thin slurry walls
- Soil mixed walls
- Jet-Grouting walls

They can be used as:

- 1) Cut-off walls underneath water dams with core seals in areas of permeable soils to socket into lower impermeable layers to prevent undercurrent
- 2) Cut-off walls for “watertight” excavation pits outside of the load-bearing retaining structure to minimize water inflow into the pit
- 3) Cut-off walls to enclose brown fields and contaminated areas with penetration into lower impermeable soil layers

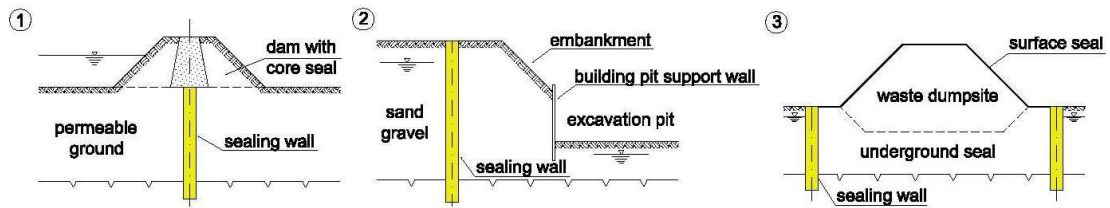


Figure 4.9 Usage of cut-off walls (5)

#### 4.1.2.1 Load bearing methods without reinforcement

For construction of cut-off wall, concrete structures as secant piles or diaphragm wall can be use. But in this case, there is no real need for reinforcing of these structures

#### 4.1.2.2 Thin slurry walls

Thin slurry walls also can act as vertical cut-off walls to retain horizontal groundwater flow.

In contrast to cut-off walls constructed using the diaphragm wall technique (replacing the soil by slurry sealant), thin slurry walls displace the soils using a vibrated steel profile. During the extraction process, sealants are injected into the created cavities. (5)

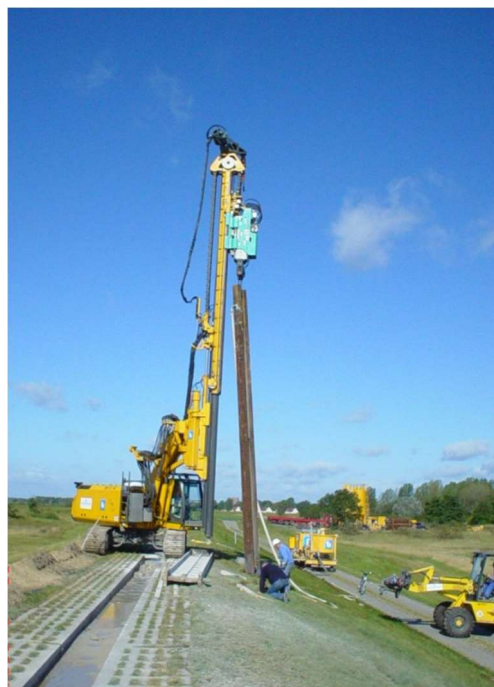


Figure 4.10 Construction of thin slurry wall (5)

Drivable soils, such as sands and gravels, are required for this installation method. The created slurry wall thickness depends on the shape of the steel profile used and the soil conditions. Thickness varies between 5 cm in sands and 20 cm in gravel. In combination with high-pressure jet grouting, wall thickness of up to 30 cm can be achieved.

A continuous wall is created by overlapping single penetration elements installed one after another by the vibrated steel profile. A guide plate attached at the beam's flange is running down the already completed web of the previous panel. This ensures the correct overlap to the previous panel.

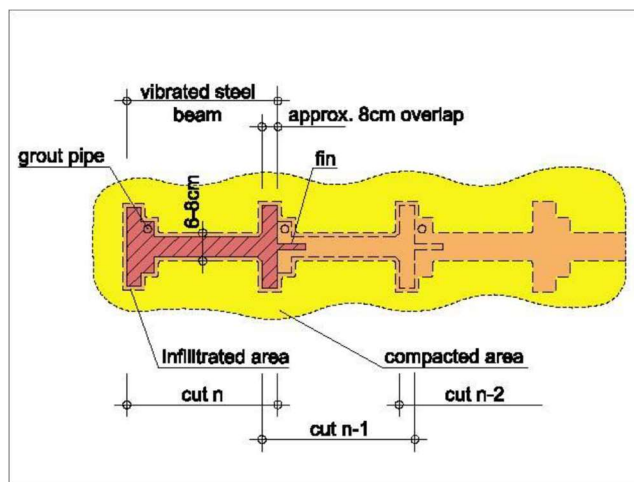


Figure 4.11 Thin slurry wall cross-section (5)

#### 4.1.2.3 Soilcrete lamella wall

Soilcrete lamella wall is method developed by Keller as combination of thin slurry walls method and deep vibration techniques. Same as thin slurry wall, this method use displacement process and injection of bentonite, but instead of steel profile, is used modified vibrator, with specific shape designed to this role.



Figure 4.12 Lamella wall (9)

#### 4.1.2.4 Deep soil mixing

The Deep Soil Mixing (DSM) was invented in Japan and Scandinavia. Its use is growing across the world in strengthening and sealing weak and permeable ground. The method helps to achieve significant improvement of mechanical and physical properties of the existing soil, which after mixing with cement or compound binders becomes the so-called soil-mix (or soil-cement). The stabilised soil material that is produced generally has a higher strength, lower permeability and lower compressibility than the native soil.

Basically, there are two different mixing methods. The existing soil which must be improved can be mixed mechanically other with a slurry including binder (wet DSM) or with a dry binder (dry DSM). Jetting of slurry can be also used to enhance mechanical mixing.

The wet method is more appropriate in soft clays, silts and fine-grained sands with lower water content and in stratified ground conditions including interbedded soft and stiff or dense soil layers.

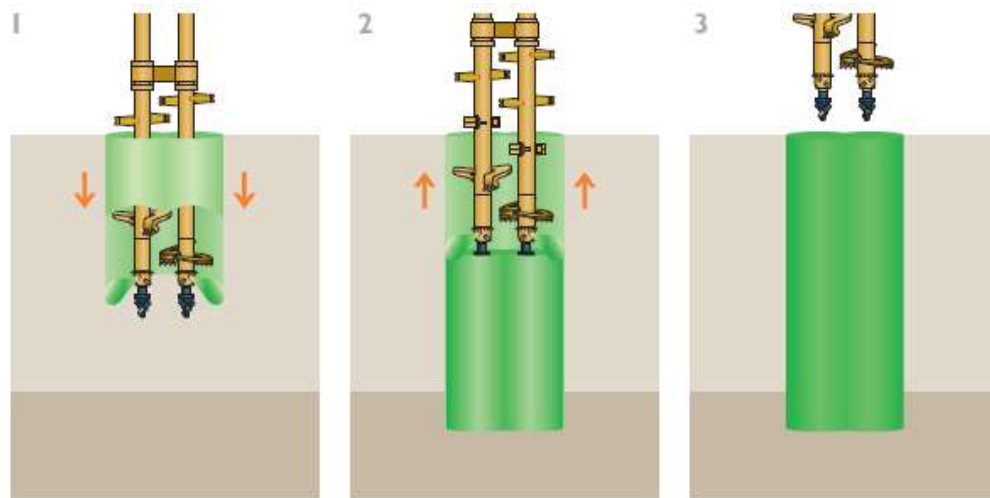
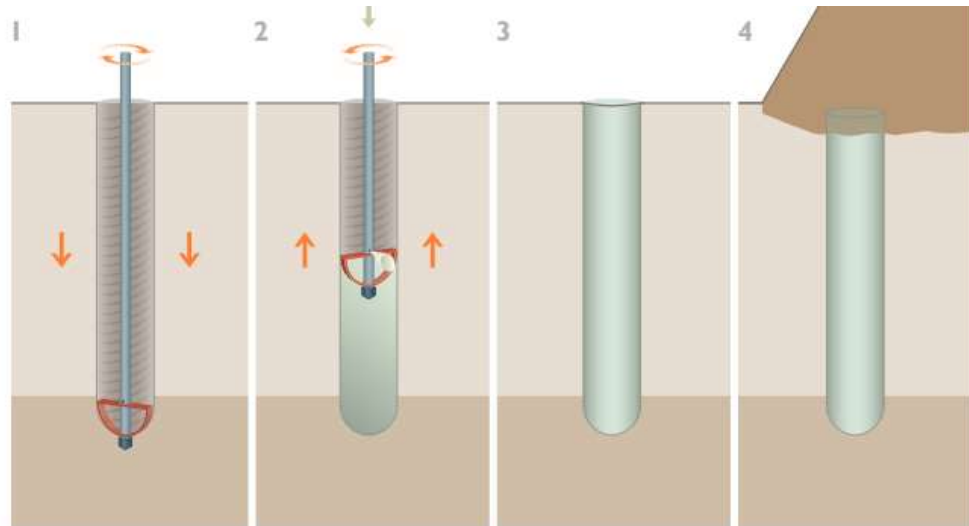


Figure 4.13 Wet mixing method (38)

The dry method is more suitable for soft soils with very high moisture content, and hence appropriate for mixing with dry binders. Stabilisation of organic soils and sludges is also possible, but is more difficult and requires carefully tailored binders and execution procedures.



**Figure 4.14 Dry mixing method (39)**

#### 4.1.2.5 Soil Mixing Wall

Soil Mixing Wall (SMW) developed by Bauer is method of soil mixing for shallow depths (6-15m), where standard deep soil mixing wouldn't be economically efficient

The soil is loosened and immediately mixed with a self-hardening suspension by three adjacent slightly overlap-ping augers and mixing paddles.

By loosening, conveying and mixing of the soil, minimum friction between rods and mixed soil is ensured. Therefore, it is possible to construct walls effectively rigs with medium power supply.

At the same time a very homogeneous soil-cement mixture can be ensured in order to achieve a good quality of the wall.

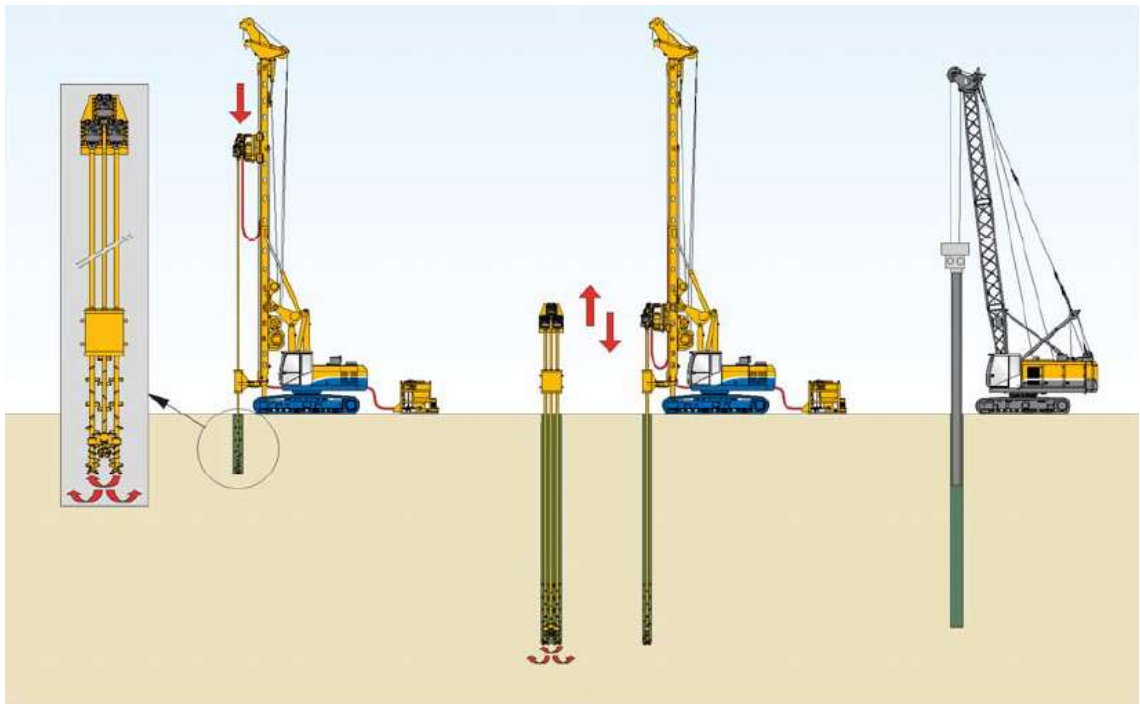


Figure 4.15 SMW construction (36)

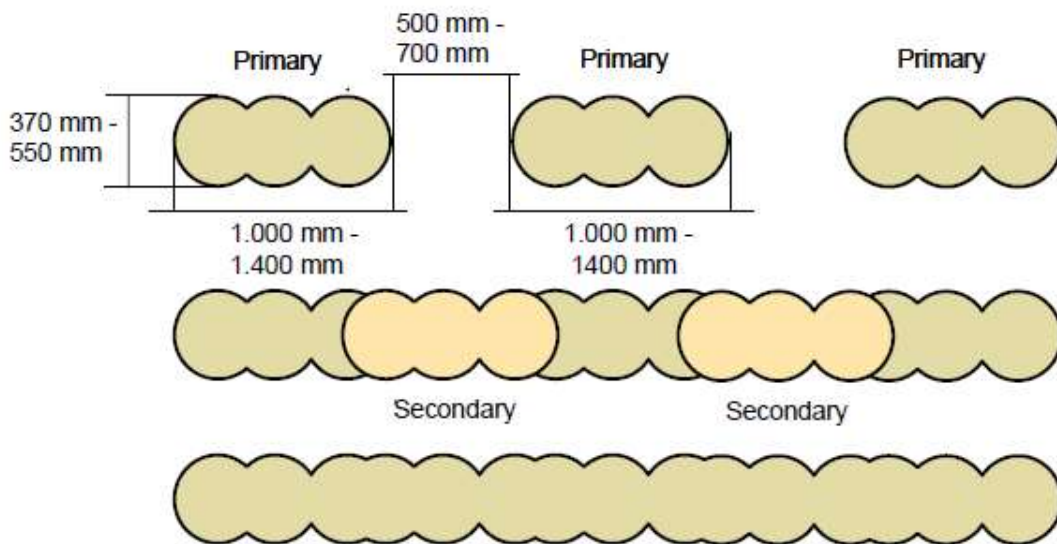


Figure 4.16 Detail of SMW (37)

#### 4.1.2.6 Cutter soil mixing wall

Cutter soil mixing (CSM) process is derived from the hydrofraise cutter diaphragm walling technique, whereby two counter rotating cutting wheels rotate about horizontal axes, but with several points of difference. During diaphragm wall construction, the hydrofraise operates as a reverse circulation process for the removal of soil and its replacement by a stabilising fluid, usually bentonite suspension; whereas in the CSM method the soil is broken up by the twin wheels, again rotating about horizontal axes, and mixed with grout which is introduced at the level of the cutter wheels. This grout/soil combination is mixed in-situ by the rotating wheels to form a self hardening soil-cement mortar.

One notable benefit derived from the use of the CSM technique is the accuracy of the installation process, by virtue of the fine degree of adjustment provided by quality installation equipment, the rigidity of the Kelly guide arrangement and the in-rig monitoring system.

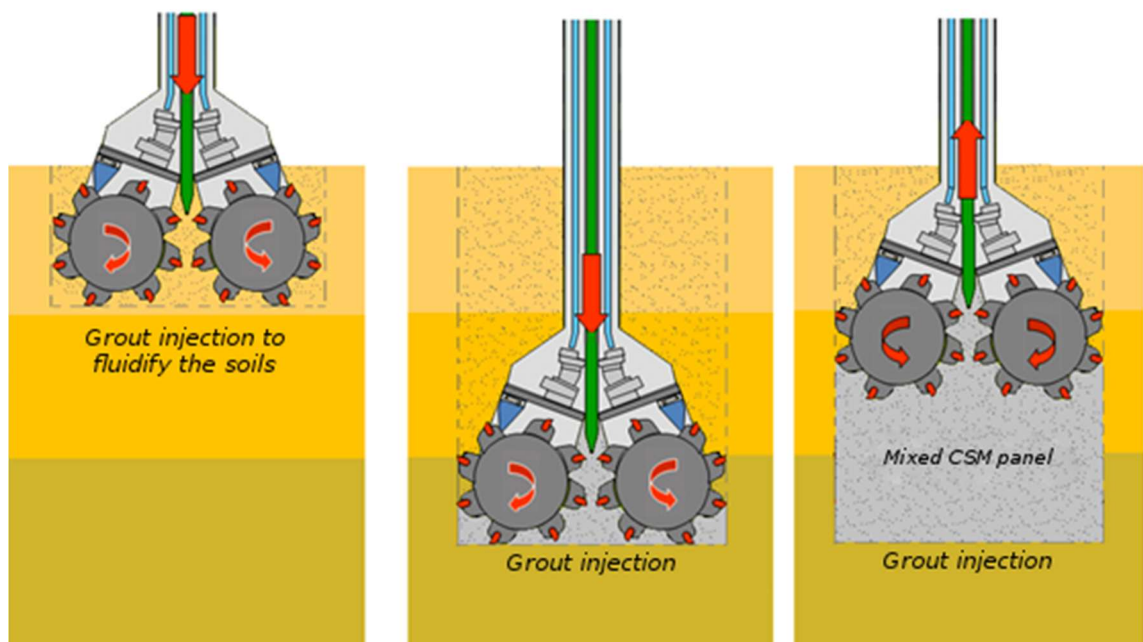


Figure 4.17 CSM working scheme (27)





**Figure 4.18 CSM application (28)**

#### *4.1.2.7 Trench cutting and Remixing Deep*

The TRD machine advances horizontally along the wall alignment while the cutter post cuts and mixes the in situ soil with cement-based binder slurry. The full-depth vertical cutter post resembles a giant chain saw, which vertically blends the entire soil profile, eliminating any stratification and creating a near homogenous soil mix wall with low permeability. The TRD method produces the most uniform wall of any soil mixing process, with certainty of continuity in deep, challenging soil conditions. (7)



Figure 4.19 TRD in practice (7)

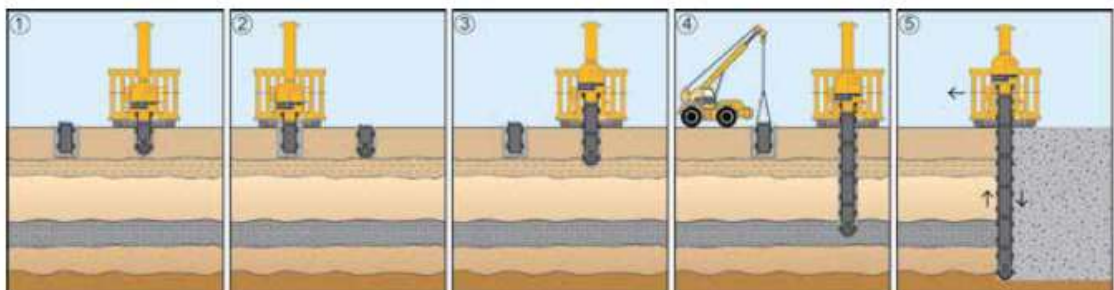


Figure 4.20 TRD work process (7)

#### 4.1.2.8 Jet Grouting

Jet grouting is a grouting technique that creates in situ geometries of soilcrete (grouted soil), using a grouting monitor attached to the end of a drill stem. The jet grout monitor is advanced to the maximum treatment depth, at which time high velocity grout jets (and sometimes water and air) are initiated from ports in the side of the monitor. The jets erode and mix the in situ soil as the drill stem and jet grout monitor are rotated and raised.

Depending on the application and soils to be treated, one of three variations is used: the single fluid system (slurry grout jet), the double fluid system (slurry grout jet surrounded by an air jet) and the triple fluid system (water jet surrounded by an air jet, with a lower grout jet). The jet grouting process constructs soilcrete panels, full columns or anything in between (partial columns) with designed strength and permeability.

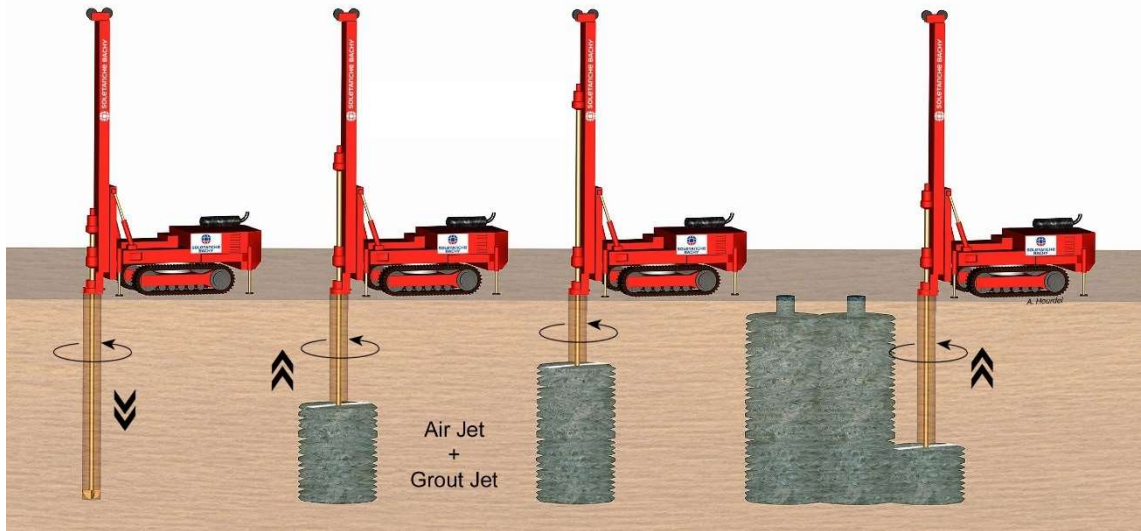


Figure 4.21 Cut-off wall construction with jet grouting (30)



Figure 4.22 Jet Grouting (31)

## 4.2 NON-WALL SOIL IMPROVEMENTS

### 4.2.1.1 Cement grouting

Cement grouting, also known as slurry grouting or high mobility grouting, is a grouting technique that fills pores in granular soil or voids in rock or soil, with flowable particulate grouts. Depending on the application, Portland cement or microfine cement grout is injected under pressure at strategic locations either through single port or multiple port pipes. The grout particle size and soil/rock void size must be properly matched to permit the cement grout to enter the pores or voids. The grouted mass has an increased strength and stiffness, and reduced permeability. The technique has been used to reduce water flow through rock formations beneath dams and to cement granular soils to underpin foundations or provide excavation support. (8)

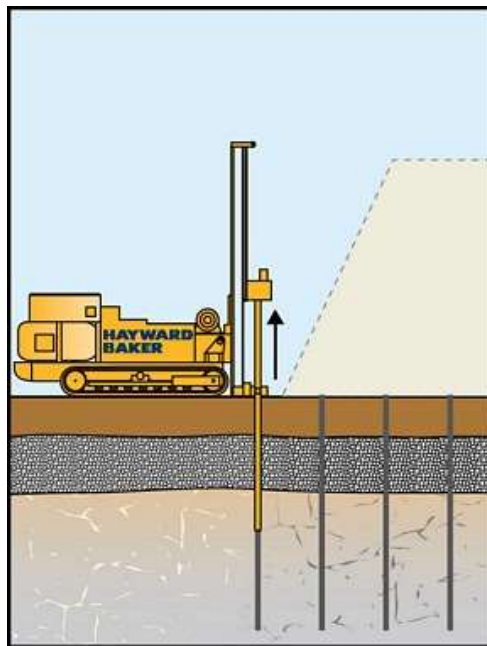


Figure 4.23 Cement grouting (8)



**Figure 4.24 Application of cement grouting (29)**

#### *4.2.1.2 Injection stabilization*

Injection stabilization is the pressure injection of aqueous solutions into the ground. The composition of the aqueous solution depends on the application, which commonly includes stabilization of expansive soils and railroad subgrades. Purpose-built injection units advance injection pipes into the treatment zone. An aqueous solution of water, lime slurry, or potassium chloride is injected to reduce shrink/swell potential for treatment of expansive soils.

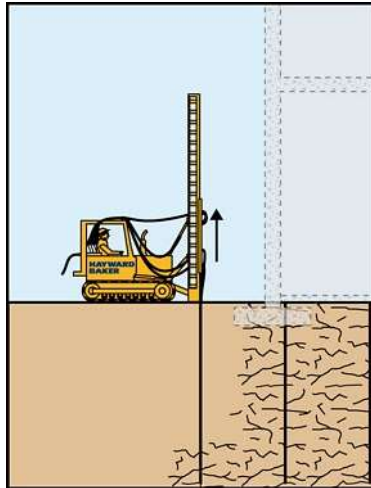


Figure 4.25 Injection stabilization (32)



Figure 4.26 Injection unit (40)

### **4.3 Floodwall foundations**

Floodwall proper anchoring in to the plain or levee is extremely important as flooding after Catarina Hurricane.

Both, demountable and permanent, floodwalls use piles which work not only as anchors, but also cantilevers.

#### **4.3.1 Foundations of permanent floodwalls**

Most common shapes of floodwall I-shape & T-shape, use steel sheet piles walls as foundation. In contrast to I-Shape, T-shape use also side anchors to increase stability.

##### *4.3.1.1 I-wall*

An I-wall is a special case of a cantilevered wall consisting of sheet piling in the embedded depth and a monolithic concrete wall in the exposed height. A cantilever wall is a wall that derives its support solely through interaction with the surrounding soil. I-walls used as floodwalls may be located on existing grade, used as a retaining wall as well as a floodwall, or used to enlarge levees.

##### *4.3.1.2 T-wall*

Cantilever T-type reinforced concrete wall consists of a concrete stem and base slab which form an inverted T. The structural members are fully reinforced to resist applied moments and shears. The base is made as narrow as practicable, but must be wide enough to ensure that the wall does not slide, overturn, settle excessively, or exceed the bearing capacity of the foundation. The bottom of the base should be below the zone subject to freezing and thawing or other seasonal volume changes. As necessary to resist underseepage during a flood event, a steel sheet pile cutoff wall is cast into the base slab of the T-Wall. The T-wall may need to be supported on a pile foundation if soft soils exist. The piles can be made of either steel or concrete and derive their support to the T-wall from friction of the soil surrounding the pile or through end bearing at a deeper stronger soil strata.

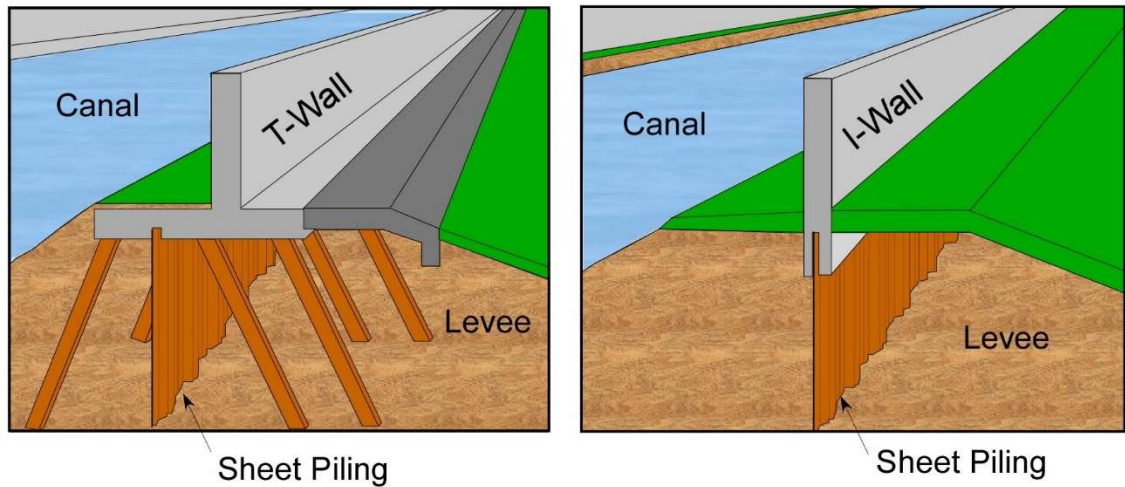


Figure 4.27 T & I walls (41)

#### 4.3.1.3 Steel sheet piles

For steel sheet usage see 4.1.1.3 Sheet pile wall

#### 4.3.1.4 Driven piles

Driven piles are deep foundation elements driven to a design depth or resistance. If penetration of dense soil is required, predrilling may be required for the pile to penetrate to the design depth. Types include timber, pre-cast concrete, steel H-piles, and pipe piles. The finished foundation element resists compressive, uplift and lateral loads. The technique has been used to support buildings, tanks, towers and bridges. Driven piles can also be used to provide lateral support for upper walls. Steel sheet piles and soldier piles are the most common type of driven piles for this application.





**Figure 4.28 Driven piles prepared for T-wall (33)**



**Figure 4.29 T-floodwall installation (35)**

### 4.3.2 Foundations of demountable floodwalls

Pre-installation of demountable walls can be achieved by simple sockets with screws for smaller structures or even sheet walls supported masonry for large rivers.

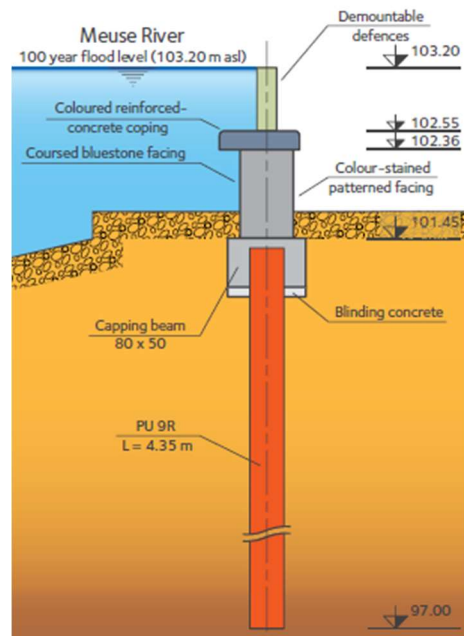


Figure 4.30 Foundation of demountable floodwall (42)



Figure 4.31 Raised Flood Wall (34)

## 5 APPLICATION IN PRAX

Upcoming examples are showing real application of variety of ground improvements methods over the world

### 5.1 Cut-off walls (Morava river, Slovakia)

Insufficient hydraulic parameters of old levees along Morava river basin were causing permanent problems with stability, what could have devastating consequences during next major flooding like in years 2002. As most common work method were used thin vibrated slurry walls, mostly created by Soilcrete® lamella walls.

Cut-off slurry wall from soilcrete was built on km 22-52 of river Morava by Keller group. Improved version of vibrated method was used. (9)



Figure 5.1 Work on cut-off wall (9)

Objective of construction was improve parameters of hydraulic flow in saturated soil to value  $k_f=1\times 10^{-8} \text{ m}\times\text{s}^{-1}$ . Works were realized form crown of wall. Wall was created mostly by clays, sand-clays, in lower parts by gravel-sand. Subsoils were mostly Neogene clays.

## 5.2 Sheet pile walls (Vltava river, Czech Republic)

As part of stabilization of channel levee, and improvement of surface of seepage steel sheet pile walls were used. Target of works was to improve stability of levee by changing flow of underground infiltration water.

Surface area of sheet pile wall was more than 21 000 m<sup>2</sup>. For construction of wall were used steel sheet piles type VL 602 (10)



Figure 5.2 Construction of steel sheet pile wall (10)

### 5.3 TRD wall, (Hoover dike, USA)

After catastrophic hurricanes in 1926 & 1928, Hoover dike around lake Okeechobee (Florida) was built in 1930s, with total length over 225km

To address the piping concerns and ensure dike stability during storm surges, the remediation program included the construction of a cut-off wall extending from the top of the levee to depths from 15 to 25m. As standard slurry wall was too expensive for size of dike, TRD method was chosen. Over 5miles was made by this method. Test after 28 days showed that permeability is no greater than  $1 \times 10^{-8}$  m/s (11)

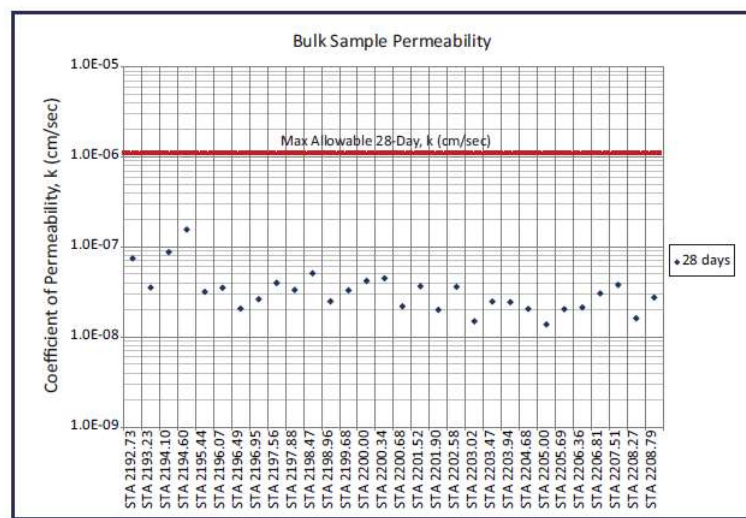


Figure 5.3 Results of permeability tests (11)



Figure 5.4 More methods were used on Hoover dike (43)

## 6 CONCLUSION

It shows, that with more and more harsh climate conditions, current, many times old, levees made by simple heaping soil to the shape of levee are not suitable sustain record extreme floods.

It can be expected, that in the future we will see increase of interest for usage of geotechnics methods for improvement of levees and for foundations of flood walls.

It should be also noted that most common methods of improvement used today are cut-off walls, which role is decrease filtration movement of water in the levees. As my own results of sensitivity calculations on mathematic model of real levee shows, filtration parameters of soils used for levee are same important as standard stability parameters. These results are supporting that use of current development of current method is on the right, as well that mathematic modelling has a great future in geotechnics as they allow engineers design economic and effective solution of levee improvement without need of real experimental model to analyse filtration behaviour in the wall.

## REFERENCES

1. **LaFrance, Adrienne.** The Atlantic. [Online] [Datum: 24. May 2017.] <https://www.theatlantic.com/technology/archive/2015/08/a-brief-history-of-levees/402119/>.
2. **Dungeness Flood Hazard Advisory Committee.** clallam county. [Online] 2009. [http://www.clallam.net/environment/assets/applets/DRFP\\_AppB\\_.pdf](http://www.clallam.net/environment/assets/applets/DRFP_AppB_.pdf).
3. **ČSN 75 2935.** *Posuzování bezpečnosti vodních děl při povodních.* Praha : Úřad pro technickou normalizaci, metrologii a státní zkušebnictví, 2014. s. 16.
4. **ČSN 75 0250** *Zásady navrhování a zatížení konstrukcí.* Praha : Úřad pro technickou normalizaci, metrologii a státní zkušebnictví, 2012. s. 32.
5. **Implenia spezialtiefbau GmbH.** Implemenia. [Online] 2014. [http://www.spezialtiefbau.implenia.com/fileadmin/con-spezialtiefbau/prospekte/englisch/Diaphragm\\_walls\\_Cut-off\\_walls\\_and\\_slurry\\_walls.pdf](http://www.spezialtiefbau.implenia.com/fileadmin/con-spezialtiefbau/prospekte/englisch/Diaphragm_walls_Cut-off_walls_and_slurry_walls.pdf).
6. **GIKEN LTD.** GIKEN. [Online] 1.. February 2015. [https://www.giken.com/en/solutions/implant\\_structure/implant\\_levee/](https://www.giken.com/en/solutions/implant_structure/implant_levee/).
7. **Hayward Baker Inc.** Hayward Baker I. [Online] November 2013. <http://www.haywardbaker.com/uploads/solutions-techniques/trd-soil-mix-walls/Hayward-Baker-TRD-Brochure.pdf>.
8. **Hayward Baker Inc.** Hayward Baker. . [Online] June 2015. [http://reports.mckinneydrilling.com/tn\\_Cement%20Grouting.jpg.img.aspx](http://reports.mckinneydrilling.com/tn_Cement%20Grouting.jpg.img.aspx).
9. **Keller Holding GmbH.** *Keller Publications – Imprint | Impressum | Mentions légales.* [USB] Offenbach, Germany : s.n., 2017.
10. **Zakládání staveb, a. s.** Zakládání staveb, a. s. [Online] 2008. [http://www.zakladani.cz/media/files/galleries/42/thumbs/03\\_resize-1317738466.JPG](http://www.zakladani.cz/media/files/galleries/42/thumbs/03_resize-1317738466.JPG).

11. Hayward Baker INC. Hayward Baker. [Online] 1. July 2009. <http://www.revbase.com/TagTeam/client/Download.asp?FileID=1031206&DataID=163368&ViewID=3>.
12. Bowles, Justin. Risk and Well-Being. [Online] 27. February 2014. <https://therationalpessimist.files.wordpress.com/2014/02/extreme-months-jpeg.jpg>.
13. The European Environment Agency. European Environment Agency. [Online] 24. May 2016. [https://www.eea.europa.eu/data-and-maps/figures/number-of-casualties-caused-by-flood-disasters-in-the-eu-1970-2005/figure-7-6-climate-change-2008-casualties.eps/image\\_large](https://www.eea.europa.eu/data-and-maps/figures/number-of-casualties-caused-by-flood-disasters-in-the-eu-1970-2005/figure-7-6-climate-change-2008-casualties.eps/image_large).
14. —. European Environment Agency. [Online] 24. May 2017. [https://www.eea.europa.eu/data-and-maps/figures/flood-losses-per-thousand-of-gdp-in-the-eu-1970-2005/figure-7-5-climate-change-2008-direct-damage.eps/image\\_large](https://www.eea.europa.eu/data-and-maps/figures/flood-losses-per-thousand-of-gdp-in-the-eu-1970-2005/figure-7-5-climate-change-2008-direct-damage.eps/image_large).
15. —. European Environment Agency. [Online] 29. November 2009. [https://www.eea.europa.eu/data-and-maps/figures/projected-change-in-damage-of-river-floods-with-a-100-year-return-period-between-2071-2100-and-1961-1990/map-7-2-climate-change-2008-change-in-100-year-flood.eps/image\\_large](https://www.eea.europa.eu/data-and-maps/figures/projected-change-in-damage-of-river-floods-with-a-100-year-return-period-between-2071-2100-and-1961-1990/map-7-2-climate-change-2008-change-in-100-year-flood.eps/image_large).
16. Topa, M.E., Giugni, M. a De Paola, F. ASCE/library. [Online] 1. January 2015. <http://ascelibrary.org/cms/attachment/17380/485492/figure1.gif>.
17. Casas, Angeles , a iní. Research Gate. [Online] January 2011. [https://www.researchgate.net/profile/Angeles\\_Casas2/publication/251494082/figure/fig2/AS:320724360286209@1453478054378/fig-2-Sketch-of-the-geometry-levee-de-fi-nition.png](https://www.researchgate.net/profile/Angeles_Casas2/publication/251494082/figure/fig2/AS:320724360286209@1453478054378/fig-2-Sketch-of-the-geometry-levee-de-fi-nition.png).
18. Hellevang, Kenneth. Extension. [Online] <http://articles.extension.org/sites/default/files/w/e/eb/Sand4.JPG>.
19. City of Albany. City of Albany. [Online] 7. January 2017. [https://www.cityofalbany.net/images/stories/publicworks/engineering/na\\_floodplain\\_study/image002.gif](https://www.cityofalbany.net/images/stories/publicworks/engineering/na_floodplain_study/image002.gif).



20. TERRAMAR GmbHENGINEERING & MACHINERY (THAILAND) Co.,Ltd. TERRAMAR. [Online] 2016. [http://www.terramar.co.th/OtherIndustries/AquaStop/Drawing%20Mob\\_1.png](http://www.terramar.co.th/OtherIndustries/AquaStop/Drawing%20Mob_1.png).
21. SENNEBOGEN Maschinenfabrik GmbH. SENNEBOGEN. [Online] 2017. [https://www.sennebogen.com/fileadmin/\\_migrated/news\\_uploads/IMG\\_1151.JPG](https://www.sennebogen.com/fileadmin/_migrated/news_uploads/IMG_1151.JPG).
22. Railsystem . Railsystem . [Online] 2015. <http://www.railsystem.net/wp-content/uploads/2016/09/secantti.jpg>.
23. BAUER-Pileco Inc. BAUER-Pileco . [Online] 2017. [http://www.bauerpileco.com/export/shared/images/bma/schlitzgefraest.png\\_73593812.png](http://www.bauerpileco.com/export/shared/images/bma/schlitzgefraest.png_73593812.png).
24. GEOSTAV spol. s r.o. GOESTAV. [Online] 3., July 2015. <http://www.geostav.cz/wp-content/uploads/2015/07/03-Vranany.jpg>.
25. GIKEN LTD. GIKEN. [Online] 1. February 2015. <https://www.giken.com/en/wp-content/uploads/%E9%8B%BC%E7%9F%A2%E6%9D%BF%E4%BA%8C%E9%87%8D%E7%B7%A0%E5%88%87.jpg>.
26. —. GIKEN. [Online] 1. February 2015. [https://www.giken.com/en/wp-content/uploads/%E5%84%AA%E3%82%8C%E3%81%9F%E8%80%90%E9%9C%87%E3%80%81%E8%80%90%E6%B4%A5%E6%B3%A2%E6%80%A7%E8%83%BD\\_en.png](https://www.giken.com/en/wp-content/uploads/%E5%84%AA%E3%82%8C%E3%81%9F%E8%80%90%E9%9C%87%E3%80%81%E8%80%90%E6%B4%A5%E6%B3%A2%E6%80%A7%E8%83%BD_en.png).
27. BAUER Maschinen GmbH. BAUER GROUP. [Online] January 2016. <https://www.bauer.de/export/shared/documents/pdf/bma/datenblatter/905-656-2.pdf>.
28. BAUER Foundation Corp. BAUER Foundation . [Online] 2015. [http://www.bauerfoundations.com/export/sites/www.coastalcaisson.com/images/references/neue\\_groesse\\_galerie/hhd-2\\_480\\_x\\_360.jpg](http://www.bauerfoundations.com/export/sites/www.coastalcaisson.com/images/references/neue_groesse_galerie/hhd-2_480_x_360.jpg).
29. Hayward Baker INC. Hayward Baker. [Online] 2015. <http://reports.mckinneydrilling.com/WolfCreekDam.jpg.dimg.aspx?Width=88&Height=78>.

30. Metacrust. MetaCrust. [Online] 2014. [http://www.bachy-soletanche.com.hk/UserFiles/Image/drawing%20jet%20grouting\(1\).jpg](http://www.bachy-soletanche.com.hk/UserFiles/Image/drawing%20jet%20grouting(1).jpg).
31. Geo-solutions. Geosolutions . [Online] 2008. <http://www.geo-solutions.com/images/grouting-dam-grouting-lake-needwood-dam-md-1.jpg>.
32. Hayward Baker INC. Hayward Baker. [Online] 2014. [http://reports.mckinneydrilling.com/tn\\_Injection%20Systems.jpg.img.aspx](http://reports.mckinneydrilling.com/tn_Injection%20Systems.jpg.img.aspx).
33. Constructor. Constructor Magazine . [Online] 2011. [http://www.constructormagazine.com/wp-content/uploads/2013/03/LPV\\_2.jpg](http://www.constructormagazine.com/wp-content/uploads/2013/03/LPV_2.jpg).
34. IBS Engineered Products Ltd. FADS directory. [Online] 2010. <http://www.ibsengineeredproducts.co.uk/medien/2spalter/Demountable-2.jpg>.
35. Center for Earthquake Engineering Simulation. NEES. [Online] 2015. <http://www.nees.rpi.edu/wp-content/uploads/2012/03/twall-construction.jpg>.
36. BAUER Maschinen GmbH . BAUER Maschinen. [Online] <http://www.bauer.de/export/shared/images/bma/smwverfahren.png>.
37. BAUER maschinen GmbH. BAUER . [Online] march 2012. [https://www.bauer.de/export/shared/documents/pdf/bma/datenblatter/info\\_39\\_e.pdf](https://www.bauer.de/export/shared/documents/pdf/bma/datenblatter/info_39_e.pdf).
38. Keller Grundbau GmbH. Keller. [Online] January 2014. <http://www.kellergrundbau.de/files/uploads/projekte/32-50i-Kita-Zittau-2014-002.jpg>.
39. Keller Holding GmbH. Keller. [Online] 2017. [http://www.kellerholding.com/files/keller/content/images/services\\_solutions/techniques/keller\\_dsm-dry.png](http://www.kellerholding.com/files/keller/content/images/services_solutions/techniques/keller_dsm-dry.png).
40. Hayward Baker INC. Hayward Baker . [Online] 20. July 1998. <http://www.revbase.com/TagTeam/client/Download.asp?FileID=302949&DataID=25637&ViewID=3>.

41. Nelson, Stephen A. Tulane University. [Online] 10. Decemeber 2012.  
<http://www.tulane.edu/~sanelson/Katrina/Katrina%20Images/floodwall%20types.jpg>.
42. ArcelorMittal Commercial RPS S.a.r.l. ArcelorMittal. [Online] 2016.  
[http://sheetpiling.arcelormittal.com/uploads/files/AMCRPS\\_Flood-Defence\\_GB.pdf](http://sheetpiling.arcelormittal.com/uploads/files/AMCRPS_Flood-Defence_GB.pdf).
43. Copyright Geosyntec Consultants, Inc. geosyntec consultant . [Online]  
[https://www.geosyntec.com/media/k2/items/cache/6577c6b0fbc4ba9ae61ff6583dc67c84\\_XL.jpg](https://www.geosyntec.com/media/k2/items/cache/6577c6b0fbc4ba9ae61ff6583dc67c84_XL.jpg).

## PICTURE LIST

- FIGURE 1.1 EXTREME MONTHS IN UK (12)
- FIGURE 1.2 CASUALTIES OVER EUROPEAN UNION OVER LAST DECADES (13)
- FIGURE 1.3 DIRECT DAMAGE OVER EUROPEAN UNION OVER LAST DECADES (14)
- FIGURE 1.4 PREDICTIONS OF FLOOD DAMAGE IN NEXT 100 YEARS (15)
- FIGURE 2.1 TEMPORARY PROTECTION (18)
- FIGURE 2.2 DEMOUNTABLE PROTECTION SYSTEM (20)
- FIGURE 2.3 PERMANENT PROTECTION SYSTEM (17)
- FIGURE 2.4 RIVER CROSS-SECTION DIVISION (19)
- FIGURE 2.5 OFF-STREAM POND (16)
- FIGURE 2.6 DETENTION POND (16)
- FIGURE 3.3.1 SCHEME OF WATER RAY IMPACTION ON CONSTRUCTION (4)
- FIGURE 3.3.2 SCHEME OF RESULTANT FROM CENTRIFUGAL FORCE (4)
- FIGURE 3.3 SCHEME OF PRESSURE NET (4)
- FIGURE 4.1 WORK ON DIAPHRAGM WALL USED FOR LEVEE IMPROVEMENT (21)
- FIGURE 4.2 CONSTRUCTION STEPS OF DIAPHRAGM WALL (23)
- FIGURE 4.3 SECANT PILE WALL CROSS-SECTION (22)
- FIGURE 4.4 CONSTRUCTION OF SECANT PILE WALL (22)
- FIGURE 4.5 STEEL SHEET PILE WALL CONSTRUCTION (24)
- FIGURE 4.6 COMMON SHAPES OF STEEL SHEET PILES
- FIGURE 4.7 IMPLANT LEVEES (25)
- FIGURE 4.8 RESISTANCE OF IMPLANT LEVEES (26)
- FIGURE 4.9 USAGE OF CUT-OFF WALLS (5)
- FIGURE 4.10 CONSTRUCTION OF THIN SLURRY WALL (5)
- FIGURE 4.11 THIN SLURRY WALL CROSS-SECTION (5)
- FIGURE 4.12 LAMELLA WALL (9)
- FIGURE 4.13 WET MIXING METHOD (38)
- FIGURE 4.14 DRY MIXING METHOD (39)
- FIGURE 4.15 SMW CONSTRUCTION (36)
- FIGURE 4.16 DETAIL OF SMW (37)
- FIGURE 4.17 CSM WORKING SCHEME (27)
- FIGURE 4.18 CSM APPLICATION (28)
- FIGURE 4.19 TRD IN PRACTICE (7)
- FIGURE 4.20 TRD WORK PROCESS (7)
- FIGURE 4.21 CUT-OFF WALL CONSTRUCTION WITH JET GROUTING (30)
- FIGURE 4.22 JET GROUTING (31)
- FIGURE 4.23 CEMENT GROUTING (8)

FIGURE 4.24 APPLICATION OF CEMENT GROUTING (29)  
FIGURE 4.25 INJECTION STABILIZATION (32)  
FIGURE 4.26 INJECTION UNIT (40)  
FIGURE 4.27 T & I WALLS (41)  
FIGURE 4.28 DRIVEN PILES PREPARED FOR T-WALL (33)  
FIGURE 4.29 T-FLOODWALL INSTALLATION (35)  
FIGURE 4.30 FOUNDATION OF DEMOUNTABLE FLOODWALL (42)  
FIGURE 4.31 RAISED FLOOD WALL (34)  
FIGURE 5.1 WORK ON CUT-OFF WALL (9)  
FIGURE 5.2 CONSTRUCTION OF STEEL SHEET PILE WALL (10)  
FIGURE 5.3 RESULTS OF PERMEABILTY TESTS (11)  
FIGURE 5.4 MORE METHODS WERE USED ON HOOVER DIKE (43)

## **TABLE LIST**

TABLE 3.1 REQUIRED SAFETY FOR DESIGN AND ASSESSMENT OF WATER  
STRUCTURE

TABLE 3.2 ORIENTATION VALUES OF RUNUP