

BRNO UNIVERSITY OF TECHNOLOGY

Faculty of Electrical Engineering
and Communication

BACHELOR'S THESIS

Brno, 2020

Ondřej Pavelka



BRNO UNIVERSITY OF TECHNOLOGY

VYSOKÉ UČENÍ TECHNICKÉ V BRNĚ

FACULTY OF ELECTRICAL ENGINEERING AND COMMUNICATION

FAKULTA ELEKTROTECHNIKY
A KOMUNIKAČNÍCH TECHNOLOGIÍ

DEPARTMENT OF FOREIGN LANGUAGES

ÚSTAV JAZYKŮ

LABORATORY TASKS FOR ANALOGUE TECHNOLOGY

LABORATORNÍ ÚLOHY PRO PŘEDMĚT ANALOGOVÁ TECHNIKA

BACHELOR'S THESIS

BAKALÁŘSKÁ PRÁCE

AUTHOR

AUTOR PRÁCE

Ondřej Pavelka

SUPERVISOR

VEDOUCÍ PRÁCE

Mgr. Petra Langerová

BRNO 2020

Bakalářská práce

bakalářský studijní obor **Angličtina v elektrotechnice a informatice**

Ústav jazyků

Student: Ondřej Pavelka

ID: 203159

Ročník: 3

Akademický rok: 2019/20

NÁZEV TÉMATU:

Laboratorní úlohy pro předmět Analogová technika

POKYNY PRO VYPRACOVÁNÍ:

Seznamte se s úlohami vyučovanými v rámci laboratorních cvičení předmětu Analogová technika. Navrhněte možné modifikace případně zcela nové úlohy s ohledem na inovaci daného předmětu. Výstupem práce budou detailní návody, které budou obsahovat zadání, úvod do probírané problematiky, postup práce, schéma měření a očekávané výsledky.

DOPORUČENÁ LITERATURA:

MALVINO, Albert Paul a David J. BATES. Electronic principles. Eighth edition. New York: McGraw-Hill Education, 2015. ISBN 9780073373881.

FLOYD, Thomas L. Electronic devices: electron flow version. 9th ed. Boston: Prentice Hall, c2012. ISBN 0-1-254985-9.

Termín zadání: 6.2.2020

Termín odevzdání: 12.6.2020

Vedoucí práce: Mgr. Petra Langerová

doc. PhDr. Milena Krhutová, Ph.D.
předseda oborové rady

UPOZORNĚNÍ:

Autor bakalářské práce nesmí při vytváření bakalářské práce porušit autorská práva třetích osob, zejména nesmí zasahovat nedovoleným způsobem do cizích autorských práv osobnostních a musí si být plně vědom následků porušení ustanovení § 11 a následujících autorského zákona č. 121/2000 Sb., včetně možných trestněprávních důsledků vyplývajících z ustanovení části druhé, hlavy VI. díl 4 Trestního zákoníku č.40/2009 Sb.

ZADÁNÍ

Seznamte se s úlohami vyučovanými v rámci laboratorních cvičení předmětu Analogová technika. Navrhněte možné modifikace případně zcela nové úlohy s ohledem na inovaci daného předmětu. Výstupem práce budou detailní návody, které budou obsahovat zadání, úvod do probírané problematiky, postup práce, schéma měření a očekávané výsledky.

ABSTRAKT

Předmět Analogová technika se zabývá základními analogovými funkčními bloky a jejich využití v současných elektronických zařízeních. Skládá se z přednášek a laboratorních cvičení, kde si studenti mohou ověřit nabyté znalosti v praxi. Tato práce obsahuje detailní návody s postupem řešení všech laboratorních úloh, měřených během celého semestru v laboratorních cvičeních. Tato cvičení slouží jako pomůcka pro lepší pochopení problematiky předmětu Analogová technika. Návody se skládají z teorie týkající se probíraného tématu, požadovanými úkoly, které má student splnit, schémat zapojení a pokud to daná úloha vyžaduje, tak i potřebných matematických vzorců k výpočtu požadovaných hodnot. Pro lepší názornost a k ověření správnosti postupů práce se v obvodech využije osciloskop. Návody také obsahují tabulky k vytištění a zapsání vypočítaných hodnot, které jsou výstupem některých úloh. Hlavním cílem této práce je zvýšit úroveň znalostí studentů předmětu Analogová technika a zvýšit efektivitu práce v laboratořích.

KLÍČOVÁ SLOVA

Analogová technika, tranzistor, operační zesilovač, zpětná vazba, diferenciální zesilovač, generátor, stejnosměrný zdroj

ABSTRACT

Subject Analog Technology focuses on basic analogue functional blocks and their usage in modern electronic devices. Theoretical part of a particular topic is taught at lectures and laboratory exercises are used to demonstrate specific examples to strengthen student's knowledge. This paper contains comprehensive manuals with measuring procedures for all compulsory laboratory tasks, for students, to better understand all topics discussed in the subject Analog Technology. These manuals include theory regarding certain topic, mandatory tasks for students, connection diagrams and in some cases, necessary math equations to calculate outcome values. To verify correctness of a working procedure and for clarity an oscilloscope will be utilized. These manuals also contain tables as attachments, which are prepared to be printed and filled in with calculated values that are the outcome of some laboratory tasks. The main purpose of this thesis is to enhance the level of knowledge of students attending the subject Analog Technology and to improve effectiveness of the work in laboratories.

KEYWORDS

Analog technology, transistor, operational amplifier, feedback, differential amplifier, oscillator, DC power source

PAVELKA, O. *Laboratorní úlohy pro předmět Analogová technika*. Brno: Vysoké učení technické v Brně, Fakulta elektrotechniky a komunikačních technologií, Ústav jazyků, 2020. 74 s. Bakalářská práce. Vedoucí práce: Mgr. Petra Langerová

PROHLÁŠENÍ

Prohlašuji, že svoji bakalářskou práci na téma Laboratorní úlohy pro předmět Analogová technika jsem vypracoval samostatně pod vedením vedoucího bakalářské práce a s použitím odborné literatury a dalších informačních zdrojů, které jsou všechny citovány v práci a uvedeny v seznamu literatury na konci práce.

Jako autor uvedené bakalářské práce dále prohlašuji, že v souvislosti s vytvořením této bakalářské práce jsem neporušil autorská práva třetích osob, zejména jsem nezasáhl nedovoleným způsobem do cizích autorských práv osobnostních a/nebo majetkových a jsem si plně vědom následků porušení ustanovení § 11 a následujících zákona č. 121/2000 Sb., o právu autorském, o právech souvisejících s právem autorským a o změně některých zákonů (autorský zákon), ve znění pozdějších předpisů, včetně možných trestněprávních důsledků vyplývajících z ustanovení části druhé, hlavy VI. díl 4 Trestního zákoníku č. 40/2009 Sb.

V Brně dne

.....

(podpis autora)

ACKNOWLEDGEMENTS

I would like to sincerely thank to Mgr. Petra Langerová for supervising my bachelor's thesis and I would like to thank to Ing. Vilém Kledrowetz Ph.D. for the help and advice he gave me regarding technical aspect of this thesis.

CONTENTS

1. Introduction.....	1
2. Transistor amplifier.....	3
2.1. Single stage transistor amplifier.....	3
2.2. Bipolar transistors	4
2.3. Different configurations	5
2.3.1. Common-emitter configuration.....	5
2.3.2. Common-base configuration.....	7
2.3.3. Common-collector configuration.....	8
3. Operational amplifier	9
3.1. Ideal operational amplifier	10
3.2. Inverting amplifier	11
3.3. Noninverting amplifier.....	12
3.4. Other configurations.....	13
3.4.1. Voltage follower	13
3.4.2. Difference amplifier.....	14
3.4.3. Summing amplifier	14
3.4.4. Comparator	15
4. Oscillator.....	16
4.1. Linear oscillator	16
4.1.1. Phase-shift oscillator	17
4.2. Non-linear oscillator.....	18
4.2.1. Schmitt trigger oscillator.....	19
4.2.2. Astable multivibrator	20
4.2.3. Monostable multivibrator.....	21
5. DC power supply.....	22
5.1. Rectifier circuits.....	23
5.1.1. Half-wave rectification	24
5.1.2. Full-wave rectification	25
5.2. Filters	27

5.2.1. Capacitor-input filter.....	27
5.2.2. Ripple factor.....	28
5.3. Voltage regulators	29
5.3.1. Linear and switching regulators	31
5.4. Efficiency of a DC power supply	32
5.5. Source of power loss	32
6. Laboratory manuals for students.....	33
6.1. Transistor amplifier CE manual	33
6.1.1. Objectives	33
6.1.2. Theory	33
6.1.3. Connection diagram	34
6.1.4. Working procedure	35
6.1.5. Workplace equipment	36
6.2. Difference and summing operational amplifier manual.....	37
6.2.1. Objectives	37
6.2.2. Theory	37
6.2.3. Connection diagram	37
6.2.4. Working procedure	39
6.2.5. Workplace equipment	40
6.3. Astable multivibrator manual.....	41
6.3.1. Objectives	41
6.3.2. Theory	41
6.3.3. Connection diagram	42
6.3.4. Working procedure	44
6.3.5. Workplace equipment	45
6.4. Simple DC source manual.....	45
6.4.1. Objectives	45
6.4.2. Theory	45
6.4.3. Connection diagram	48
6.4.4. Working procedure	49

6.4.5. Workplace equipment	51
6.4.6. Measured values.....	51
7. Conclusion	53
8. Rozšířený abstrakt	55
9. List of references	58
9.1. Online sources	59
10. List of figures.....	60
11. List of tables	63

1. INTRODUCTION

Analog technology is a subject taught in the 2nd year of a bachelor study programme “English in Electrical Engineering and Informatics”. The programme is a combination of an electrical engineering and linguistics. During three years of studies students have to pass many different subjects from each field, that is English and electrical engineering.

Analog technology covers many different topics from modern world, where basic functional blocks and analogue elements are parts of each device. These are then essential in conversion of a signal from analogue into digital, and vice versa.

Course curriculum includes: amplifiers, bipolar junction transistors (BJT), field-effect transistors (MOSFETs), transistor amplifiers, operational amplifiers, oscillators with feedback and basic direct current (DC) power supplies.

The subject Analog technology is composed of lectures and obligatory laboratory exercises, where students are required to utilize acquired knowledge from lectures. The laboratory exercises include tasks based on topics: transistor amplifier, astable multivibrator and DC power source. During each of these three tasks a pair of students has to assemble particular circuit and perform given tasks to obtain the results they need to complete successfully a particular exercise. These three tasks are main representatives of the theory discussed at lectures. Besides these, one more manual will be introduced regarding topic operational amplifiers, which in my opinion play significant role in today’s electronics, therefore students should obtain some experience in this topic. With this, the curriculum will be entirely represented also in laboratory. These four topics are also a state exam questions from the subject Analog technology.

I have chosen this topic, not only that the subject itself is highly interesting especially these days. But also to be able to help future students at my study program, which will be able to use these manuals in laboratory exercises. In my experience, and I think I do not talk just for myself but for other students too, a comprehensive manual helps significantly and can even make students more interested in given topic. I have witnessed and experienced the help of a

manual and not just the teacher, who cannot be with every group of students simultaneously, while the manual is still available.

Therefore this thesis will provide an insight into the theory of all four previously mentioned topics and furthermore four manuals that are introduced in following chapters, students should be able to complete all of the requirements without any difficulty.

In laboratories students are provided with laboratory equipment such as laboratory power source, an oscilloscope, a generator, together with cables and connection board with all necessary components, for example resistors, capacitors, transistor and diodes.

2. TRANSISTOR AMPLIFIER

Almost all electronic equipment must include means for amplifying electrical signals. This operation can do properly biased transistor which raises the strength of a weak signal and thus acts as an amplifier. (Mehta, 2008, p. 240)

Transistors are semiconductor devices that act as either electrically controlled switches or amplifiers. The convenience of transistors is the way they can control electric current flow in a manner similar to the way a faucet controls of water. With a transistor, a small voltage and/or current applied to a control lead acts to control a larger electric flow through its other two leads. The two major types of transistors are *bipolar transistors* and *field-effect transistors* (FETs). The main difference is that the bipolar transistors require a biasing input (or output) current at their control leads, whereas FETs require only a voltage – practically no current. Generally FETs are more popular in circuit design nowadays, besides drawing essentially zero current, they are easier to manufacture, cheaper to make, and can be made extremely small (integrated circuits). Nevertheless for amplifier circuits bipolar transistors are used more frequently due to their higher transconductance, thus larger voltage gain. (Scherz, 2016, p. 429)

2.1. Single stage transistor amplifier

When only one transistor with associated circuitry is used for amplifying a weak signal, the circuit is known as single stage transistor amplifier. An example can be *Figure 2*.

The amplification process starts when a weak AC signal is given to the base of a transistor, a small base current starts flowing. Due to transistor action, a much larger (β times larger) AC current flows through the collector load. Thus a weak signal applied to the base appears in amplified form in the collector circuit. That is the way how transistor acts as the amplifier. (Mehta, 2008, p. 241)

2.2. Bipolar transistors

Bipolar transistors come in either *npn* or *pnp* configurations (see *Figure 1*). An *npn* bipolar transistor uses a small input current and positive voltage at its base to control a much larger collector-to-emitter current. Conversely, a *pnp* transistor uses a small output base current and negative base voltage to control a larger emitter-to-collector current. (Scherz, 2016, p.430, 431)

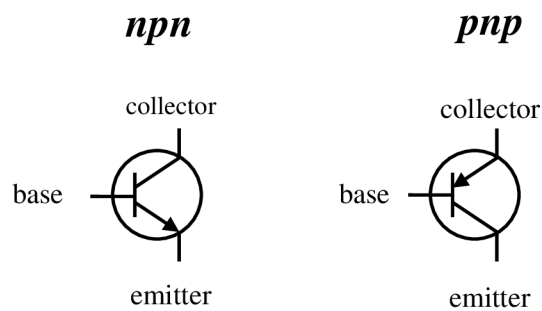

Figure 1: Bipolar transistors
(Retrieved from: Scherz, 2016, p. 431)

2.3. Different configurations

There are three useful ways how to connect a transistor, with common-emitter (CE), a common-collector (CC), or a common-base (CB). Each of these different connections has its own advantages. But for our amplifying purposes the CE connection is most widely used.

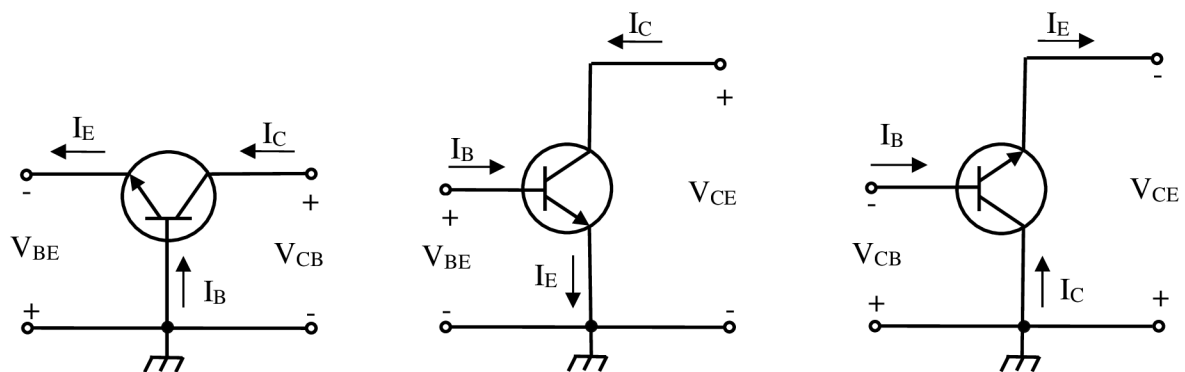

Figure 2: CB, CE, CC

(Retrieved from: <https://www.researchgate.net/>)

2.3.1. Common-emitter (CE) configuration

The emitter is at ground potential – hence the name common-emitter. C_{IN} is a coupling capacitor that couples the AC generator voltage to the base of the transistor. The internal resistance of the generator will not affect the DC bias of the transistor because the capacitor blocks DC. C_E is called an emitter bypass capacitor which provides a low-impedance path for AC signals between the emitter terminal and ground. It also holds the emitter constant. Thus, when the base voltage varies and the emitter voltage is held constant, the change is directly across the base-emitter junction of the transistor. In other words C_{IN} also together with C_C act as a short circuit as in interested to block DC. C_C also works as coupling capacitor in multi-stage amplifiers, if it is not used, the bias conditions of next stage will be drastically changed due to the shunting effect of R_C . (Schultz, 2011, p. 910, 911)

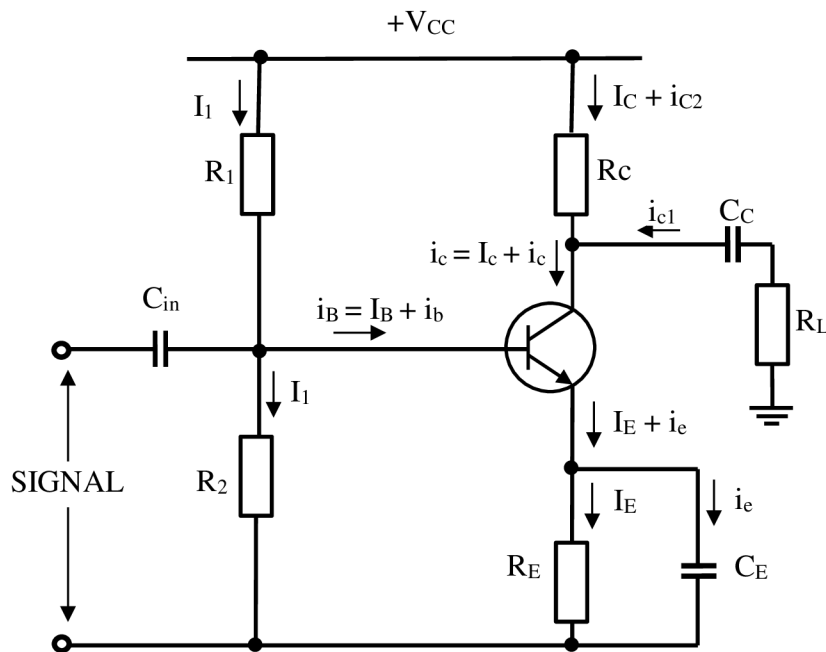

Figure 3: Common-emitter configuration
(Retrieved from: Mehta, 2008, p. 242)

In the common-emitter connection, when the input signal voltage increases in the positive sense, the output voltage increases in the negative direction and vice-versa. In other words, there is a phase difference of 180° . (Mehta, 2008, p. 244)

The input voltage is applied to the base and the output is taken from the collector.

The voltage gain is:

$$A_V = \frac{V_{OUT}}{V_{IN}} \approx -\frac{R_C}{R_E}, \quad (1)$$

where V_{OUT} is the output voltage and V_{IN} input voltage.

A common-emitter amplifier provides a large voltage gain, a large current gain, and a very high power gain. (Schultz, 2011, p. 938)

2.3.2. Common-base (CB) configuration

The common-base amplifier is used less often than the common-emitter or common-collector amplifier. The CB amplifier provides a high voltage and power gain, but the current gain is less than one. Unlike CC amplifier, the CB amplifier has extremely low input impedance. This is a significant disadvantage and that is the reason why they are used so infrequently. The low input impedance loads down the AC signal source driving the CB amplifier. However, the CB provides some desirable features for operation at higher frequencies. Another application of the CB amplifier is as a unity-gain current amplifier or current buffer. (Schultz, 2011, p. 931)

The base of a CB is grounded, the input signal is applied to the emitter and the output is taken from the collector. The output signal voltage is in phase with the input signal voltage = no phase shifting. (Schultz, 2011, p. 931)

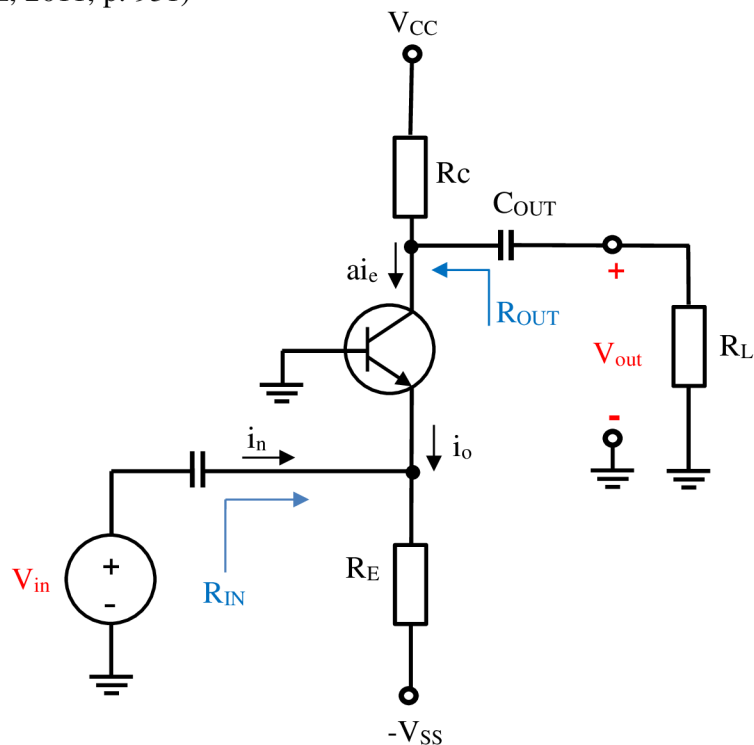

Figure 4: Common-base configuration

(Retrieved from: Analog technology – student's book p. 37)

2.3.3. Common-collector (CC) configuration

The common-collector amplifier is used to provide current gain and power gain. The voltage gain equals approximately one. As the name suggests, the collector is common to both the input and output sides of amplifier. The input signal is applied to the base and the output is taken from the emitter, therefore an emitter bypass capacitor is not used. The output signal is in phase with the input signal. Because the output signal follows the input signal, the CC amplifier is usually referred to as *emitter follower*. Important characteristics of emitter follower is that it has a high input impedance and a low output impedance, which make it ideal for impedance matching applications. (Schultz, 2011, p. 921)

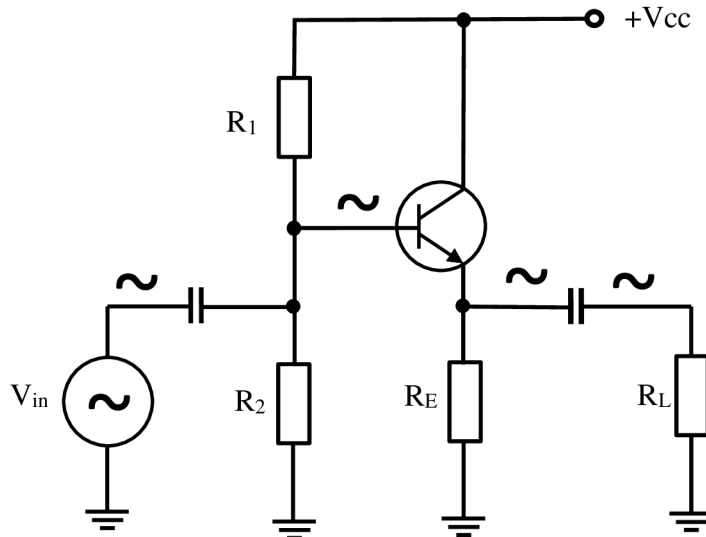
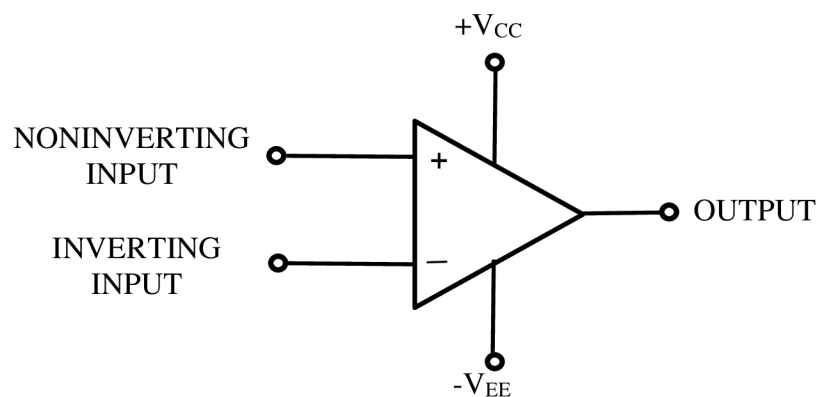

Figure 5: Common-collector configuration
(Retrieved from: Malvino, 2015, p. 334)

The output voltage is a replica of the input, but 0.6 to 0.7 volt less positive (one diode drop). For this circuit V_{IN} must stay at + 0.6V or more, or else the output will have ground potential. By returning the emitter resistor to a negative supply voltage, negative voltage swings can be permitted as well. There is also no collector resistor in an emitter follower. (Horowitz, 1989, p. 65)

3. OPERATIONAL AMPLIFIER

An operational amplifier (commonly called *op amp*, *oamp* or *opamp*) is a device that can be used to perform mathematical operations such as amplification, attenuation, addition, subtraction, integration, and differentiation. It is widely used electronic device, usually as an integrated circuit (IC). (Kang, 2016, p. 314) The circuit symbol is shown in *Figure 6*.



*Figure 6: Circuit symbol of op amp with power terminals
(Retrieved from: Malvino, 2015, p. 668)*

There are two input terminals, one output and two power supply terminals. The noninverting input “+” means that the phase shift between this input and output is zero, while inverting input with “-“ sign indicates 180° phase shift, hence the name. (Maxfield, 2008, p. 396)

The op amp is designed to sense the difference between the two inputs, to which two voltages are connected. Then the difference is multiplied by the gain A , and causes the resulting voltage to appear at the output. Thus the output voltage is:

$$V_{out} = A * (v_2 - v_1), \quad (2)$$

where A is the gain and v_1 and v_2 are the voltages at inputs.

The A is called the *open-loop voltage gain* because it is the gain of the op amp without any external feedback from the output to input. (Alexander, 2009, p. 177)

If the op amp has only one input, then the output voltage will be:

$$V_{out} = A * v_1, \quad (3)$$

where A is the gain and v_1 is the input voltage.

3.1. Ideal operational amplifier

An op amp is ideal if it has the following characteristics:

- Infinite open-loop gain
- Infinite input resistance
- Zero output resistance
- Infinite bandwidth
- Infinite common-mode rejection

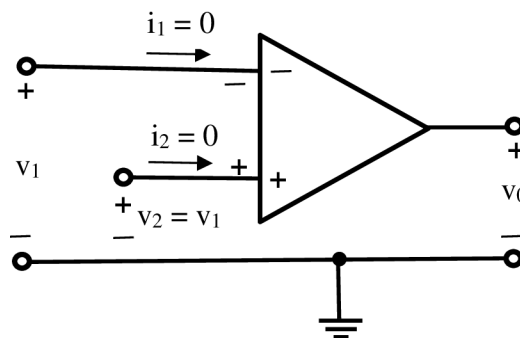

Figure 7: Ideal op amp

(Retrieved from: Alexander, 2009, p. 180)

For circuit analysis and ideal op amp is illustrated in *Figure 7*. Two important properties of ideal op amp we can derive: the current into both input terminals are zero (due to infinite

input resistance) and that the voltage across the input terminals is equal to zero; therefore these voltages are equal. These two characteristics are extremely important regarding analyzing of op amp circuits. (Alexander, 2009, p. 180)

3.2. Inverting amplifier

To make inverting amplifier, a *feedback* has to be introduced. The term feedback refers to sampling a portion of the output signal from amplifier and feeding it back either to aid or to oppose the input signal. The negative feedback means that the returning signal via a resistor is connected to the inverting terminal. If the feedback would be connected to the noninverting terminal it is called positive feedback.

The negative feedback can significantly improve the performance of the op amp, mainly by stabilizing the voltage gain, improving the input and output impedances and increasing of the bandwidth. (Schultz, 2011, p. 1054)

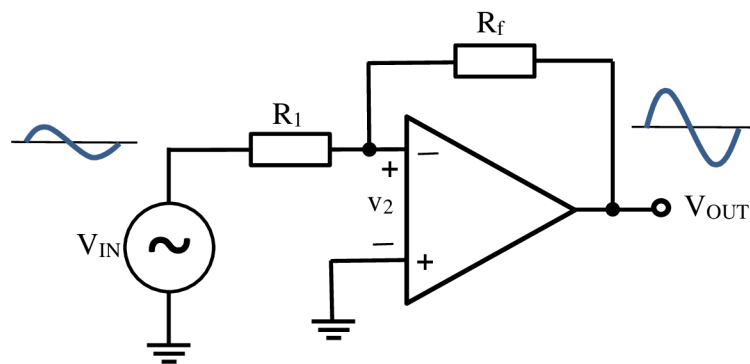

Figure 8: Inverting op amp

(Retrieved from: Malvino, 2015, p. 680)

In this circuit, the noninverting input is grounded, v_{in} is connected to the inverting input through R_1 , and the feedback resistor R_f is connected between the inverting input and the output. (Alexander, 2009, p.181) The v_{in} is amplified by the open-loop voltage gain to

produce an inverted output voltage. The output voltage is fed back to the input through feedback resistor R_f . This results in negative feedback because the output is 180° out of phase with the input. (Malvino, 2015, p. 680)

This will result in *closed-loop gain*:

$$A_{CL} = \frac{v_{out}}{v_{in}} = -\frac{R_f}{R_1}, \quad (4)$$

where v_{out} is the output voltage, v_{in} is the input voltage, R_f is the feedback resistor.

Because of the infinite gain and infinite input resistance, the current through both resistors has to be the same. Furthermore, since v_2 is zero, the *virtual ground* means that the inverting input acts like a ground for voltage but an open for current. Therefore, the *virtual ground* means having zero voltage but not physically connected to the ground.

3.3. Noninverting amplifier

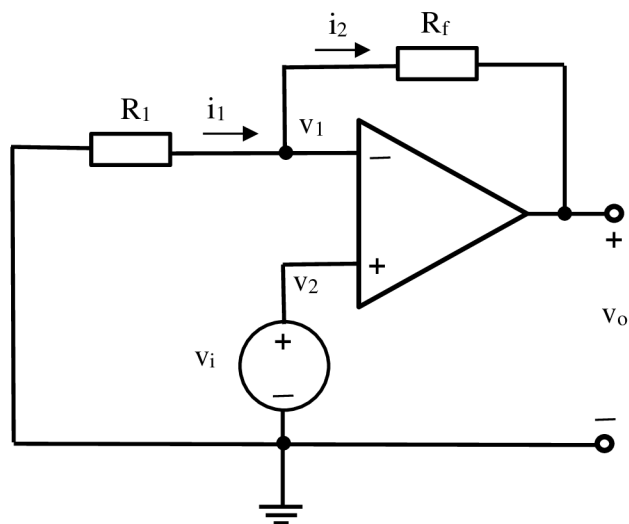

Figure 9: Noninverting op amp
(Retrieved from: Alexander, 2009, p. 183)

The input signal is directly applied to the noninverting input of the op amp, so that the input and output will be in phase. Resistor R_f is connected between the ground and the inverting terminal. The closed-loop gain is:

$$A_{CL} = \frac{v_{out}}{v_{in}} = \left(1 + \frac{R_f}{R_1}\right), \quad (5)$$

where v_{out} is the output voltage, v_{in} is the input voltage, R_f is the feedback resistor.

3.4. Other configurations

3.4.1. Voltage follower

This configuration is also called a *unity gain amplifier*, *buffer amplifier*, or *isolation amplifier*. The input voltage is applied to the noninverting terminal, therefore the input and output voltages are in phase. The output is directly connected to the inverting terminal so $v_{in} = v_{out}$. The result is a voltage gain of 1, a very high input resistance and a very high output resistance. The voltage follower is an ideal interface to use between a high-impedance source and a low-impedance load. (Schultz, 2011, p. 1060, 1061)

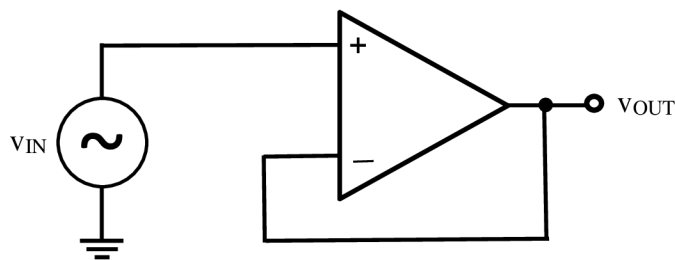

Figure 10: Voltage follower

(Retrieved from: Malvino, 2015, p. 693)

3.4.2. Difference amplifier

Difference (or differential) amplifiers are used in applications where is a need to amplify the difference between two input signals, while rejecting any common signals. (Alexander, 2009, p. 187)

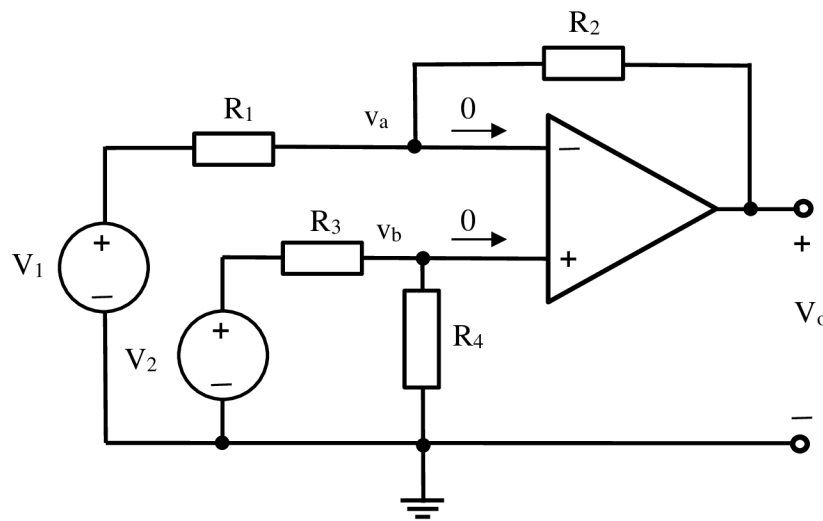

Figure 11: Difference amplifier

(Retrieved from: Alexander, 2009, p. 187)

3.4.3. Summing amplifier

Besides amplification and differentiation the opamp can perform addition, which is performed by the summing amplifier. A summing amplifier is an opamp circuit that combines several inputs and produces an output that is the weighted sum of the inputs. It takes the advantage that inverting input can handle many inputs at the same time. (Alexander, 2009, p.185) Because the inverting input has zero current, all of the input current combine to flow through the feedback resistor. Because $R_1 = R_2 = R_3$, the voltage gain of the circuit is one and the total output voltage is inverted sum of the input voltages. When the voltage gain is different for each input, formula for the output voltage becomes:

$$V_{out} = -\left(\frac{R_f}{R_1}V_1 + \frac{R_f}{R_2}V_2 + \frac{R_f}{R_3}V_3\right). \quad (6)$$

(Schultz, 2011, p. 1065)

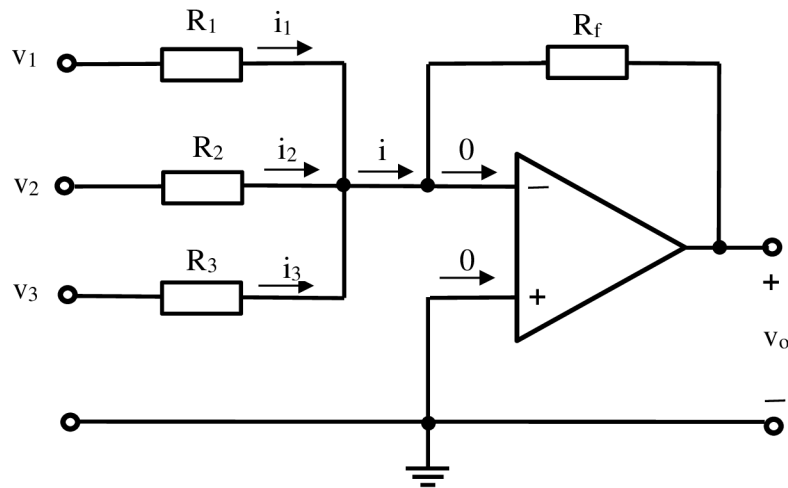

Figure 12: Summing amplifier

(Retrieved from: Alexander, 2009, p. 185)

3.4.4. Comparator

No feedback is applied in comparator, therefore the circuit uses the maximum gain of given operational amplifier. As the name suggest, a typical application for a comparator is that of comparing a signal voltage with a reference voltage. The output will go high (or low) in order to signal the result of the comparison. (Maxfield, 2008, p. 415, 416)

4. OSCILLATOR

Within nearly every electronic device it is essential to have an oscillator or waveform generator of some sort. Apart from the case of signal generators, function generators and pulse generators themselves, a source of regular oscillations is necessary in any cyclical measuring instrument. Therefore, we can find an oscillator in digital multimeters, oscilloscopes, radiofrequency receivers, computers etc. (Horowitz, 1989, p. 284)

Oscillators can produce sinusoidal (harmonic) wave, we call them *linear oscillators* or non-sinusoidal (e.g. square) waves, so called *non-linear*. The desired signal is produced only with DC power source as an input.

4.1. Linear oscillator

The basic structure of a sinusoidal oscillator is an amplifier and frequency selective network connected in positive feedback loop. The idea is to use the feedback signal in place of the input signal. If the feedback signal is large enough and has the correct phase, there will be an output signal even though there is no external input signal. (Malvino, 2015, p. 904)

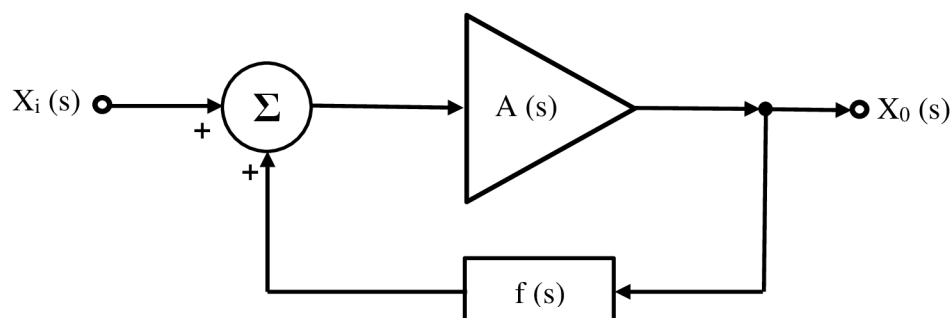

Figure 13: Linear oscillator

(Retrieved from: Schubert, 2016, p. 926)

The closed-loop gain is:

$$A_f(s) = \frac{A(s)}{1 - A(s)f(s)}. \quad (7)$$

To produce continuous undamped oscillations at the output of an amplifier, the *Barkhausen Criterion* must be fulfilled:

- The total phase shift through the whole network must be $X \cdot 360^\circ$, where $X = 1, 2, \dots$
- The magnitude of the loop gain must be constant

(Mehta, 2008, p. 369)

4.1.1. Phase-shift oscillator

The phase-shift oscillator is one of the RC oscillators, another example may be Wien-bridge oscillator.

The phase-shift oscillator is one of the simplest oscillators to design and construct in the audio frequency range. The oscillator exemplifies the simple principles and conditions of oscillation discussed previously. (Schubert, 2016, p. 930) A simple op amp phase oscillator is shown in *Figure 14*.

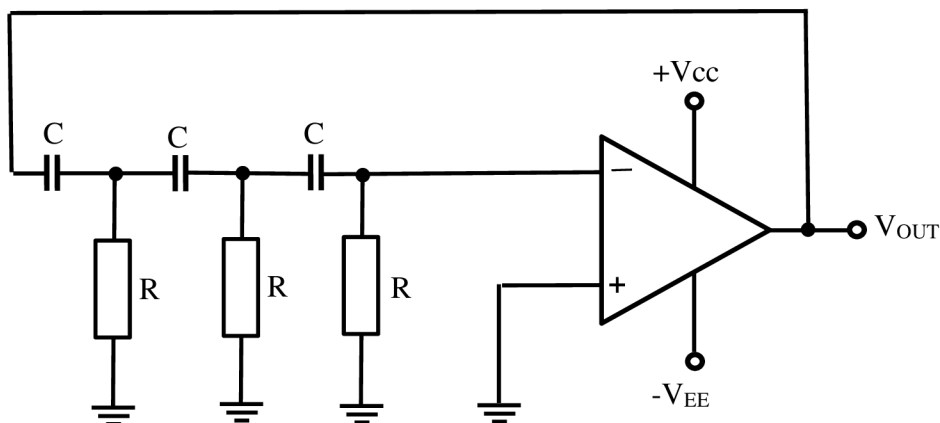

Figure 14: Phase-shift oscillator
(Retrieved from: Malvino, 2015, p. 911)

In this circuit, an inverting op amp is connected to a RC ladder network consisting of three cascaded arrangements of a resistor and a capacitor. The three resistors and three capacitors have identical values. If the reactive RC network on the inverting amplifier is neglected, the output signal would be shifted by a 180° . At a particular frequency, the RC network shifts the phase by an additional 180° (each RC connection by a 60°), resulting in a total phase shift of 0° . Therefore, the criterion to oscillate is fulfilled. (Schubert, 2016, p. 930, 931)

4.2. Non-linear oscillator

In addition to sinusoidal waveforms, electronic devices often need signals with other wave shapes. Common waveforms include single pulses of fixed duration as well as periodic square or triangular waves. Fixed-duration pulses are used primarily for timing of events in communication and control systems.

Electronic circuits that generate non-sinusoidal waveforms, such as pulse, square and triangular waveforms are typically based upon electronic *multivibrators*. These multivibrators are characterized by a very rapid transition between two distinct output states and are divided into three groups based on the time stability of these output states:

- A bistable multivibrator (or Schmitt trigger) will rest indefinitely in either output state until triggered to change state. It has two stable states.
- A monostable multivibrator has one stable state: the other state is of fixed duration that can only be activated with a triggering signal.
- An astable multivibrator has no stable state. A constant, periodic switching between quasi-stable states.

(Schubert, 2016 p. 969)

4.2.1. Schmitt trigger oscillator

One of the simplest forms of a bistable circuit is the comparator (See chapter 3.4.3.) but noise can ruin their usage as an oscillator, therefore a positive feedback will be used. Positive feedback retains the rapid output transition of comparator, but alerts the trigger level. This circuit is called Schmitt trigger oscillator:

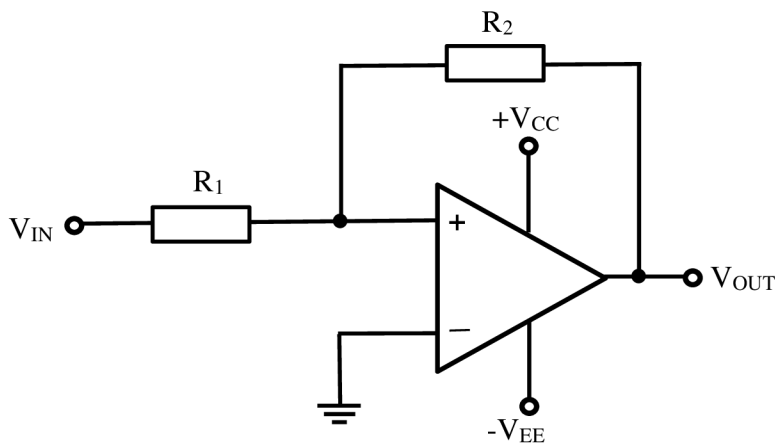

*Figure 15: Noninverting Schmitt trigger oscillator
(Retrieved from: Malvino, 2015, p. 867)*

Aside from being especially useful in converting slowly varying or a noisy signal into a clean, pulsed form with sharp transitions, the Schmitt trigger is particularly useful in converting sine-wave input into a pulse-train output. (Schubert, 2016 p. 972)

The Schmitt trigger can be realized in many configurations. When comparator is used as the basic active element, inverting and non-inverting forms are realized. The additional resistors provide stable reference voltage. (Schubert, 2016 p. 972)

A bistable multivibrator can also be used in special connection to create a triangular waveform. An integrator will be connected to the output of the bistable multivibrator, which causes linear charging and discharging of capacitor, thus creating triangular waveform.

4.2.2. Astable multivibrator

An astable multivibrator continuously transition between quasi-stable output states. The output of the astable therefore becomes a square wave with the waveform as a possible variable. An example of one such stable circuit is shown in *Figure 15*. Here are the two inputs to a comparator coupled to the output through two different type networks. The non-inverting input is connected through a resistive voltage divider and the inverting terminal is connected to the output by an RC charging network. This input exponentially transitions toward the output voltage. When the inverting input voltage matches the voltage at the non-inverting input, the output voltage toggles to the other quasi-stable state. This output toggling cause successive exponential change and toggling. (Schubert, 2016, p. 974)

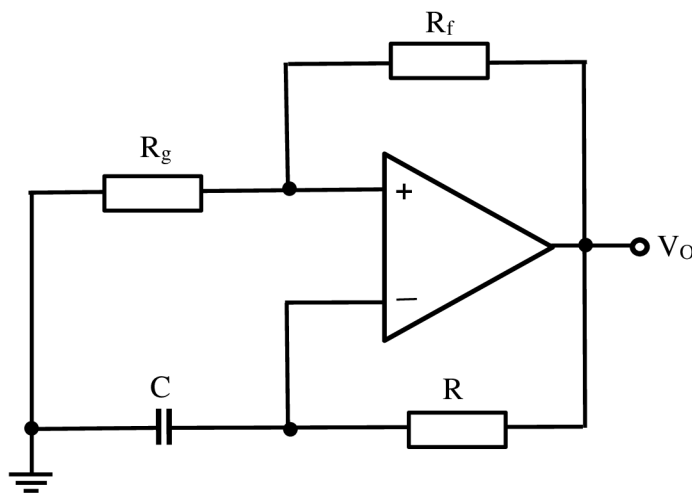

Figure 16: Astable multivibrator
(Retrieved from: Schubert, 2016, p. 974)

4.2.3. Monostable multivibrator

A monostable multivibrator produces a single output pulse, typically of precise amplitude and duration, each time trigger signal is applied to the input. As such, monostable multivibrators are useful in transforming a train of pulses with variable amplitude and/or duration into a train of pulses with standard amplitude duration. The output during the single pulse is a quasi-stable: between pulses the output is stable. (Schubert, 2016, p. 975)

A stable multivibrator can be transformed into a monostable multivibrator by stabilizing one of the quasi-stable output states. The circuit has its negative output stabilized by the introduction of stabilizing diode. This diode prevents the inverting input, from becoming sufficiently negative to fall below the lower non-inverting state. (Schubert, 2016, p. 976)

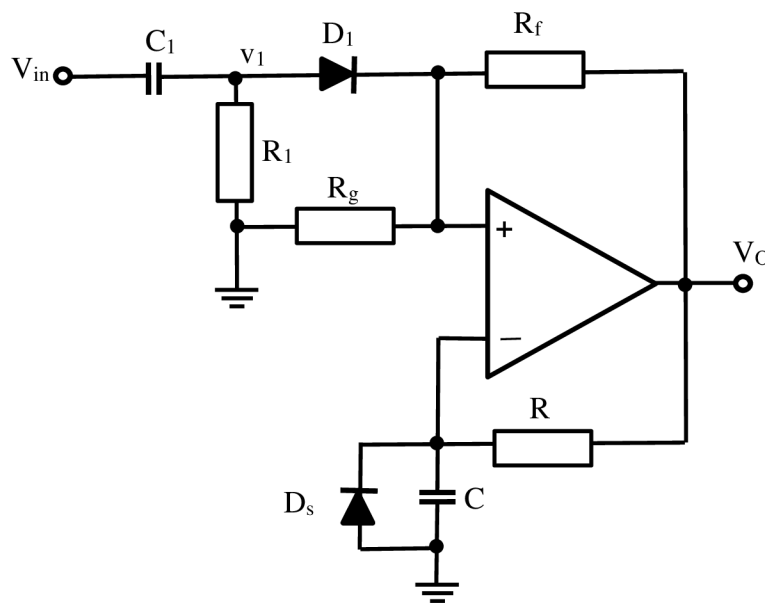

Figure 17: Monostable multivibrator
(Retrieved from: Schubert, 2016, p. 976)

5. DC POWER SUPPLY

Circuits and devices usually require a DC power supply that can maintain a fixed voltage while supplying enough current to drive a load. Batteries and fuel cells are reliable DC sources, but their relatively low current capacities make them impractical for driving higher current, more frequently used circuits. An alternative solution is to take a 230V AC, 50 Hz line voltage and convert it into suitable DC voltage. (Scherz, 2016, p. 699)

Power sources can either stand alone or be build-in with the load e.g. personal computer. Also, the energy can be obtained from various sources and not just from the wall outlets, for instance fuel cells or renewable energy.

The process of converting the AC line voltage into a usable (typically lower) DC voltage is to use an input transformer to step down the AC voltage. After that, the transformed voltage is applied through a rectifier network to get rid of the negative swings (or positive swings if a negative voltage supply is designed). After negative swings are eliminated, a filter network is used to flatten out the rectified signal into a nearly flat DC voltage, which is then provided by regulator to the load. (Scherz, 2016, p. 699)

The example of a DC power source is shown in *Figure 17*. below, as well as the signal at each step which is being converted from AC to certain value DC.

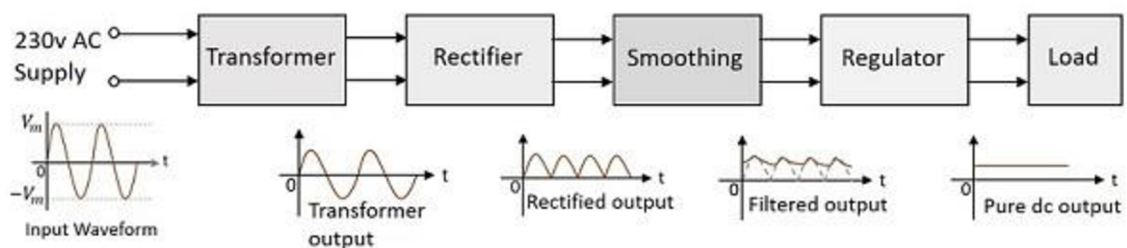

Figure 18: DC power source

(Retrieved from: <https://steemit.com/>)

There are two approaches to do this conversion. The more traditional approach is to use a step-down transformer (“linear supply”). The other approach is to use a “switch-mode” power supply. This method is more recent and has already taken over “linear power supplies”, which are rather simple devices consisting of only a few elements (Gurevich, 2014, p. 55). As a result of this change, every-day used power supplies got smaller and lighter. (Scherz, 2016, p. 699)

5.1. Rectifier circuits

The output signal of the step-down transformer has now required value, however it is still an AC signal, therefore a rectification to one polarity is needed. For that purpose a single diode can be used. A diode is a two-lead nonlinear semiconductor device that acts as one-way gate to the flow of electric current. When a diode’s anode lead is made more positive in voltage than its cathode lead – a condition called forward biasing – current is permitted to flow through the diode. However, if the polarities are reversed – a condition referred to as reversed biasing – the diode acts to block current flow. (Scherz, 2016, p. 407) Therefore only positive part of a sine wave continues further. This process is called “half-wave rectification” which is a simpler solution. Another type is “full-wave rectification” that is the more efficient solution.

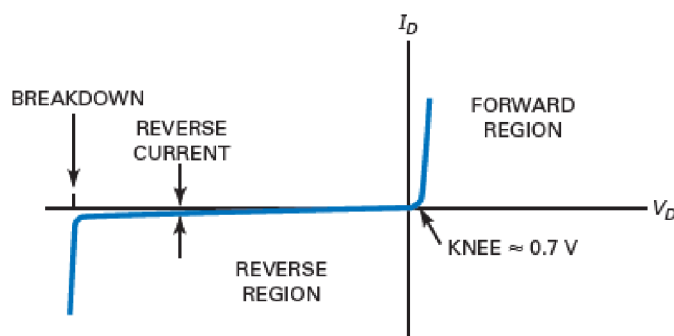

Figure 19: V-I Characteristic of a diode
(Retrieved from: Malvino, 2015, p. 59)

5.1.1. Half-wave rectification

Figure 19. shows a half-wave rectifier circuit. The AC source produces a sinusoidal voltage. Assuming an ideal diode, the positive half-cycle of the signal will forward-bias the diode, therefore this positive half-cycle of the input signal will appear across the load resistor. On the negative half-cycle, the diode is reverse biased, hence no voltage appears across the load resistor. (Malvino, 2015, p. 88)

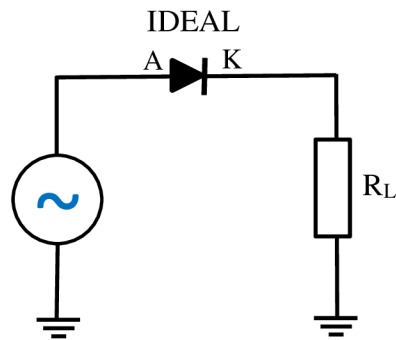

Figure 20: Half-wave rectifier circuit
(Retrieved from: Malvino, 2015, p. 88)

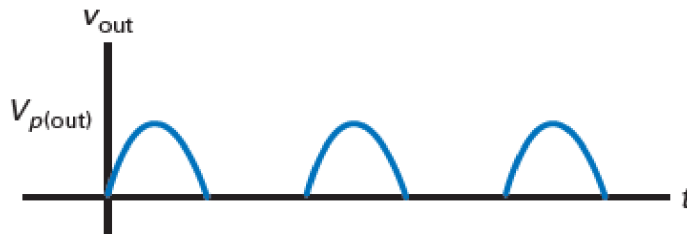

Figure 21: Half-wave rectified signal
(Retrieved from: Malvino, 2015, p. 88)

The average value of the half-wave rectified voltage is the same as the value a DC voltmeter would measure. Therefore the efficiency of this rectification is only around 31.8 %. Hence the equation:

$$V_{DC} = \frac{V_p}{\pi}, \quad (8)$$

where V_p is peak value of the signal.

5.1.2. Full-wave rectification

Similarly to the half-wave rectifier, a full-wave rectifier circuit produces an output voltage or current which has only the DC component. Full-wave rectifiers have some fundamental advantages over half-wave rectifiers. The average (DC) output voltage is twice as higher than in half-wave, the output has also much less ripple and produces smoother output waveform. (https://www.electronics-tutorials.ws/diode/diode_6.html)

In a full-wave rectifier circuit two diodes are used, one for each half of the cycle. A multiple winding transformer is used whose secondary winding is split equally into two halves with a common centre tapped connection. This configuration results in each diode conducting in turn when its anode terminal is positive with respect to the transformer centre point, producing an output during both half-cycles. The connection diagram is shown on the next page in *Figure 21*. together with resulting output signal. (https://www.electronics-tutorials.ws/diode/diode_6.html)

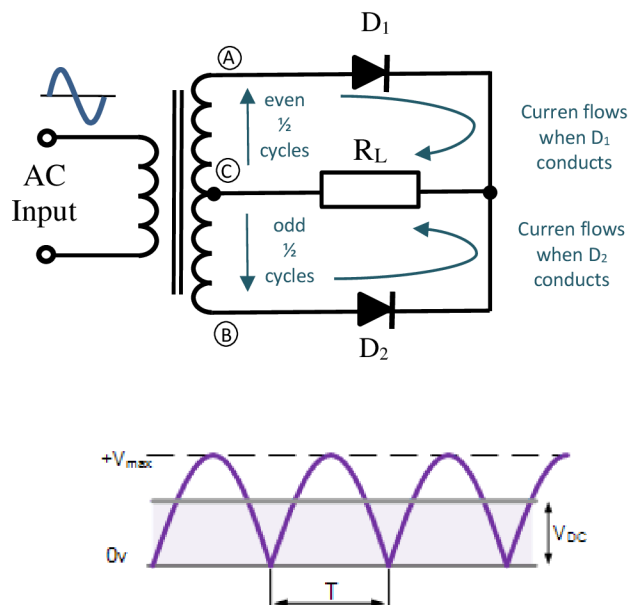

Figure 22: Full-wave rectifier circuit and output signal
 (Retrieved from: <https://www.electronics-tutorials.ws/>)

Thus the resulting efficiency is around 63.7 % and average voltage is:

$$V_{AVG} = \frac{2 * V_p}{\pi}, \quad (9)$$

where V_p is the peak value of the signal.

A different type of circuit that produces the same full-wave rectification is a full-wave bridge rectifier. This type of rectifier uses four individual rectifying diodes connected in closed loop “bridge” configuration to produce the desired output. The main advantage of this bridge circuit is that it does not require a special centre tapped transformer, thereby reducing its size and cost. (https://www.electronics-tutorials.ws/diode/diode_6.html)

The four diodes are arranged in “series pairs” with only two diodes conducting current during each half cycle. During the positive half cycle of the supply, diodes D_1 and D_2 conduct in series while diodes D_3 and D_4 are reversed biased and the current flows through the load. During the negative half cycle, diodes D_3 and D_4 conduct in series while diodes D_1 and D_2 are reversed bias. (https://www.electronics-tutorials.ws/diode/diode_6.html)

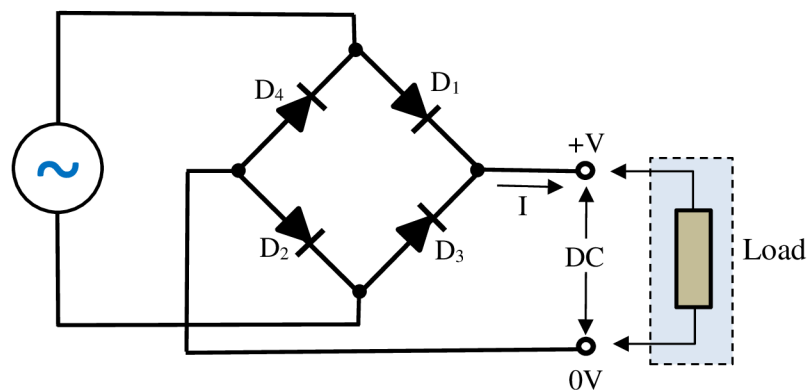

Figure 23: Full-wave bridge rectifier circuit
 (Retrieved from: <https://www.electronics-tutorials.ws/>)

5.2. Filters

After transforming the input AC voltage and rectifying the signal to only one polarity either by half-wave or full-wave rectifier additional filtering/smoothing of a signal is necessary. The filter is a device that allows passing the DC component of the load and blocks the AC component of the rectifier output. Thus the output of the filter circuit will be a steady DC voltage. The filter can be constructed by the combination of components like capacitors, resistors and inductors. In DC power supply a capacitor as a filtering device is used. (<http://www.circuitstoday.com/filter-circuits>)

5.2.1. Capacitor-input filter

A capacitor-input filter is a filter circuit in which a high value capacitor is connected in parallel with the output of the rectifier in a linear power supply. The capacitor increases the DC voltage and decreases the ripple of the output voltage.

This capacitor, when placed across a rectifier output gets charged to the maximum value of the supply voltage and stores the charged energy during the conduction period (when rectifying diodes are forward biased). When the capacitor is fully charged, it holds the charge until the input AC supply to the rectifier reaches the negative half cycle.

When the rectifier is not conducting (diodes reversed biased = negative part of sinusoidal waveform) this energy charged by the capacitor is delivered to the load. Since the rectifier diode conducts only in the forward direction, any energy discharged by the capacitor will flow into the load. Through this energy storage and delivery process, the time duration during which the current flows through the load resistor gets increased and the ripples are decreased. This will result in output of a DC voltage with waveform called “sawtooth” (*See Figure 23.*). (<http://www.circuitstoday.com/filter-circuits>) Therefore the signal does not have an ideal DC waveform yet, so a regulator in next step of a DC source will be used. It will be discussed in next subchapter.

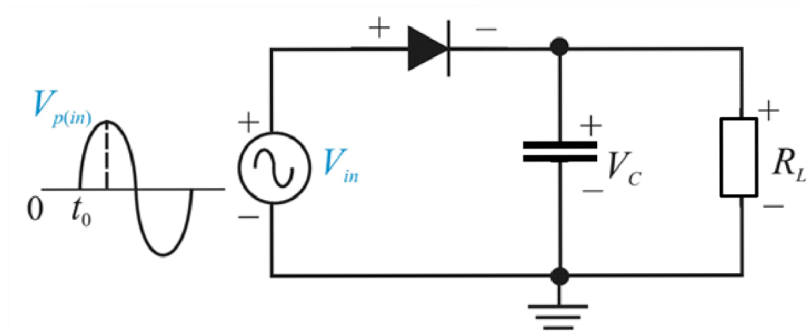

Figure 24: Capacitor-input filter circuit
 (Retrieved from: <https://www.chegg.com/study>)

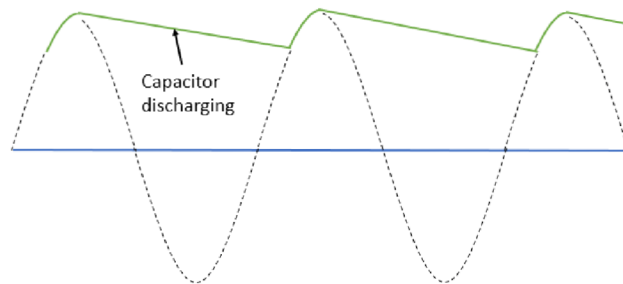

Figure 25: Filtered signal by capacitor
 (Retrieved from: <https://lecturesclub.com/>)

5.2.2. Ripple factor

The ripple factor r is an indication of the effectiveness of the filter and is defined as:

$$r = \frac{V_{r(p-p)}}{V_{DC}}, \quad (10)$$

where $V_{r(p-p)}$ is the peak-to-peak value of filtered voltage and V_{DC} is DC voltage (or average) of input signal.

The smaller the peak-to-peak value of this ripple, the more closely the output approaches a perfect DC voltage i.e. the better filter. (Malvino, 2015, p. 104) By increasing the load resistance or increasing the value of filter capacitor a ripple can be lowered.

If the full-wave or bridge rectifier is connected to capacitor-input filter, the peak-to-peak ripple is cut in half, because the capacitor discharges for only half as long. Therefore, the peak-to-peak ripple is half the size it would be with a half-wave rectifier. (Malvino, 2015, p. 105)

5.3. Voltage regulators

The signal has already passed the transformer, the rectifier and the filter, nevertheless the signal is still unregulated. This means that if there are any sudden surges within the AC input voltages (spikes, dips, etc.) these variations will be expressed at the supply's output. Using an unregulated power supply with sensitive low current circuits may end by damaging the devices in that circuit. An unregulated supply also has a problem maintaining a constant output voltage as the load resistance changes. If a highly resistive (low-current) load is replaced with lower-resistance (high-current) load, the unregulated output voltage will drop. For that reason a special circuit, called regulator, has to be connected across the output of an unregulated supply to convert it into regulated supply - a supply that eliminates the spikes and maintains a constant output voltage with load variations. (Scherz, 2016, p. 700)

A voltage regulator is designed to adjust automatically the amount of current flowing through the load, by comparing the supply's DC output with a fixed or programmed internal reference voltage. A simple regulator consists of a sampling circuit, an error amplifier, a conduction element, and a voltage reference element. (Scherz, 2016, p. 700)

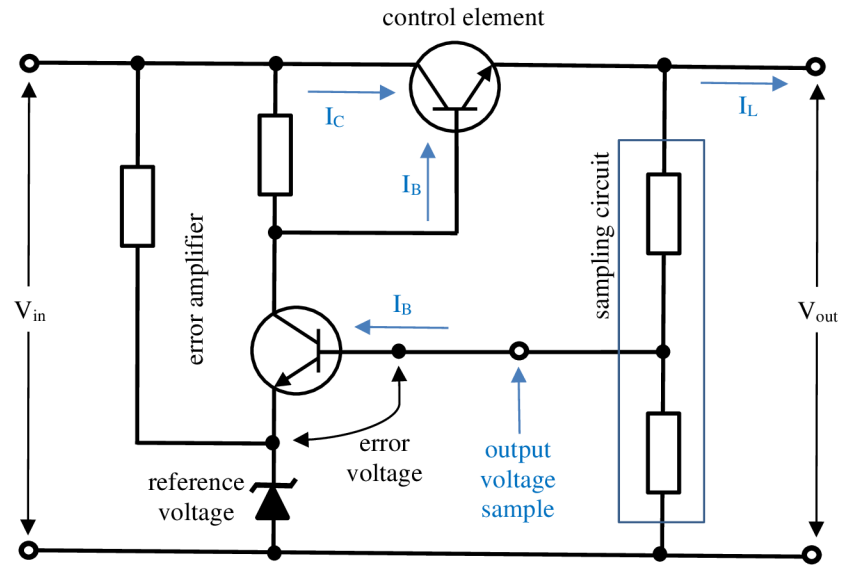

Figure 26: Voltage regulator
 (Retrieved from: Scherz, 2016, p. 700)

The regulator's sampling circuit (voltage divider) monitors the output voltage by feeding a sample voltage back to the error amplifier. The reference voltage elements (Zener diode) acts to maintain a constant reference voltage that is used by an error amplifier. The error amplifier compares the output sample voltage with the reference voltage and then generates an error voltage if there is any difference between the two. The error amplifier's output is the fed to the current-control element (transistor), which is used to control the load current. (Scherz, 2016, p. 701)

There are two main categories of voltage regulation and that is, "load regulation" which indicates how much the load voltage changes when load current changes. And it is defined as:

$$LoadReg = \frac{V_{NL} - V_{FL}}{V_{FL}} * 100 \%, \quad (11)$$

where V_{NL} is V_{OUT} voltage with no-load current. The smaller the load regulation, the better is the power source. (Malvino, 2015, p. 960)

And “line regulation” which regulates the input line voltage. The actual voltage coming out of a power outlet may vary depending on the time of day and other factors. Since the secondary voltage is directly proportional to the line voltage, the load voltage will change when line voltage changes. (Malvino, 2015, p. 961) Line regulation is defined as:

$$LineReg = \frac{V_{\Delta OUT}}{V_{\Delta IN}} * 100 \% . \quad (12)$$

5.3.1. Linear and switching regulators

A type of regulator and power supply rapidly gaining footholds over the older linear designs is called a switching regulator. The switching regulator, as the name implies, regulates a delivery of a power to a load by switching current (or voltage) on and off. (Ashby, 2012, p. 165)

5.4. Efficiency of a DC power supply

The efficiency of a power supply module is its output power divided by its input power. The efficiency normally worsens as the load is reduced, because the various losses and operating currents assume a greater proportion of the input power. Therefore, it is not recommended to use heavily overrated power supply for its use, if the efficiency is an important factor. Linear supply efficiency also varies considerably with its input voltage, being worst at high voltages, because the excess must be lost across the regulator. Switch-mode supplies do not have this problem. (Maxfield, 2008, p. 572)

Normally efficiency is not of prime concern for main power supplies, since it is not essential to make an optimum use of the available power, although at higher powers the heat generated by an inefficient unit can be troublesome. (Maxfield, 2008, p. 573)

Linear power supplies are rarely more than 50 % efficient unless they can be matched to narrow input voltage range, whereas switch-mode power supplies can exceed 70 % and with careful design even 90 %. This makes switch-mode power supplies more popular, despite their greater complexity. (Maxfield, 2008, p. 573)

5.5. Sources of power loss

The components in a power supply that make the major contribution to losses are:

- The transformer: core losses, determined by the operating level and core material and copper losses.
- The rectifier: diode forward voltage drop (0.7 V); more significant at low voltages.
- Linear regulator: the voltage dropped across series pass element multiplied by the operating current; greater at high input voltages.
- Switching regulator: power dissipated in the switching element due to saturation voltage.

6. LABORATORY MANUALS FOR STUDENTS

This chapter includes all four manuals from previously discussed topics from the subject “Analog technology”. Each of them starts with a short reminder of theory related to the topic. The source of all the theory subchapters is a textbook for students which is not yet released. The author is fully conscious of these paraphrases.

6.1. “Transistor amplifier CE” manual

6.1.1. Objectives

Assemble a transistor amplifier in the common-emitter configuration. Use the oscilloscope to verify the correctness of a connection and to observe the amplified signal. As a next task try to replace the generator with a source of a sound e.g. phone, and carefully find out at which frequencies you are able to hear the sound. Try to change the values of capacitors and hear the differences (base, depth, pitch) and think why the changes are happening.

6.1.2. Theory

An amplifier is used to increase the amplitude of a signal, without changing any other parameters. Amplifiers are one of most commonly used circuits in electronics. Bipolar and MOS transistors are capable of providing useful amplification in three different configurations: in the common-collector or common-drain configuration, in the common-base or common-gate configuration or in the common-emitter or common-source configuration, where the signal is applied to the base or gate of the transistor and the amplified output is taken from the collector or drain. Each of these configurations provides a unique combination of parameters such as input and output resistance and voltage, power and current gain. For our purposes the CE configuration of bipolar transistor will be used.

From the connection diagram we can see that the emitter is at ground potential – hence the name common-emitter. The signal from the source of a signal is coupled into the base of the transistor through coupling capacitor C_1 , which provides the DC isolation between the amplifier and the source. Basically, it acts as a perfect short circuit at all signal frequencies while blocking DC. The CE amplifier is inverting, that is, the output signal is 180° out of phase relative to the input signal.

6.1.3. Connection diagram

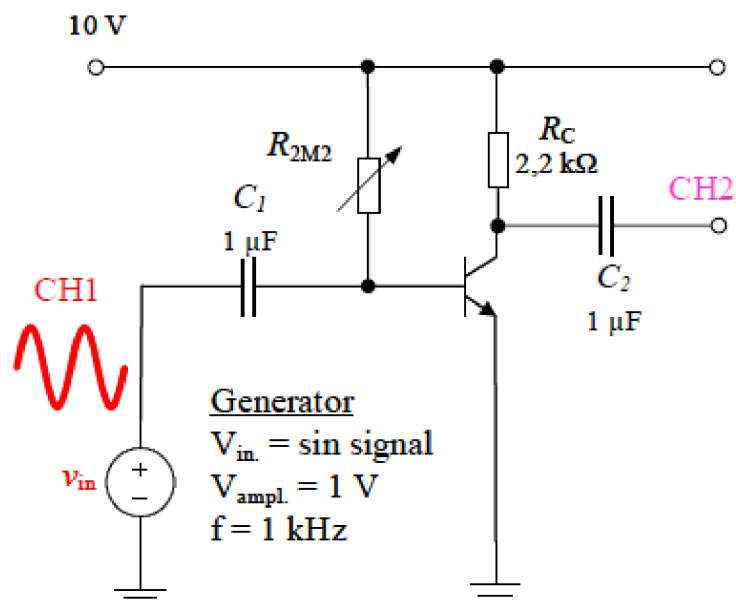

Figure 27: Connection diagram of transistor amplifier CE

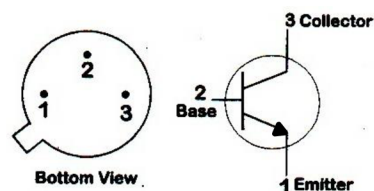

Figure 28: Schematic diagram of a transistor (bottom view)

(Retrieved from: <https://artsandscience.usask.ca/physics/>)

6.1.4. Working procedure

After assembling the circuit indicated in *Figure 27*. and before connecting it to the main power supply, always let the teacher check the circuit to prevent any material damage and to prevent any injury.

- a) Check the workplace if everything is in proper condition and if not, immediately inform the teacher.
- b) Turn on the electronic devices (the oscilloscope, the generator and the power source) to let them stabilize before connecting any cables. If the previous values have not been lowered down, do it before connecting any wires.
- c) Start connecting the circuit according to the circuit diagram *Figure 27*. Firstly, the variable resistor R_{2M2} and resistor R_C with transistor and supply of 10 V. A red LED diode on the power supply indicates if the output is ON. Set the resistance in such a way that exactly 5 V will be on the output of the transistor. Use the multimeter. The middle connection pin and one pin on no matter which side on the variable resistor has to be connected
- d) Connect the rest of the circuitry components together with two oscilloscope channels, only one needs to be connected to the ground. Generator will be set to: $f = 1 \text{ kHz}$, $V = 1 \text{ V}$, *sinusoidal waveform*. The coaxial cable will be connected from the output to the connection board, where the bottom connection pin will be ground and the top connected to the desired place. There is a LED diode under the button “output” which indicates if the signal is generated.
- e) Try to change the capacitances at the output and at the input and see how the signal changes its properties. Do these changes always without the supply of 10 V.
- f) Substitute the laboratory generator with your own source of sound by using a Jack 3.5 cable and connect your headphones at the output. The Jack connection port will have the bottom pin connected to the ground and two remaining connected if you want to use both left and right channel of your headphones.
- g) Again try different capacitors and listen how the sound changes its properties.
- h) Try out carefully which frequencies you are able to hear.

- i) Lower down all the values on devices to zero and disconnect all cables. Clean the workplace.

6.1.5. Workplace equipment

Oscilloscope Rigol MSO1074 and two coaxial cables

Generator Agilent 33210A and coaxial cable

Laboratory source Diametral L240R51D with wires

Digital multimeter Keysight 34461A

Connection board

Set of black and red wires to use on the connection board

Transistor

Source of sound and headphones

Cable with Jack connector 3.5

6.2. “Difference and summing operational amplifier” manual

6.2.1. Objectives

In Task 1 create a circuit with operational amplifier called “summing amplifier”. Verify that the output voltage of this amplifier is an inverted sum of all input voltages. In task 2 a different mathematical operation will be created by using an operational amplifier, the difference amplifier. The aim is to prove that the output voltage is the difference of two input voltages.

6.2.2. Theory

An operational amplifier (op amp) is an electronic device that can perform mathematical operations, such as amplification, summing, subtraction and many more. The operational amplifier has two inputs, one output and two power supply inputs. The op amp can be either in inverting or noninverting connection depending at which input terminal is grounded.

The difference amplifier is one that responds to the difference between the two signals applied at its input while the summing amplifier has at the output a weight sum of input voltages.

6.2.3. Connection diagram

Depending on the availability of the laboratory you will use either one or two generators. If the teacher does not say otherwise, treat the two sources of the signals as a one, the same signal will be on both inputs.

Task 1: Summing amplifier

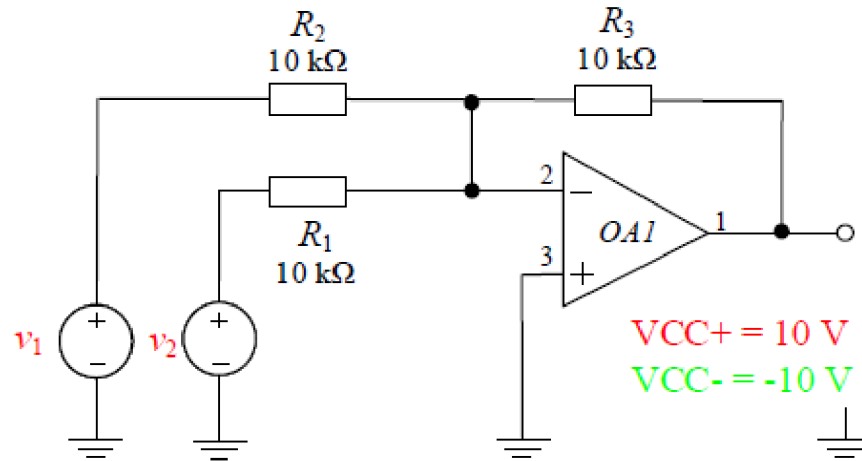

Figure 29: Connection diagram of summing amplifier

Task 2: Difference amplifier

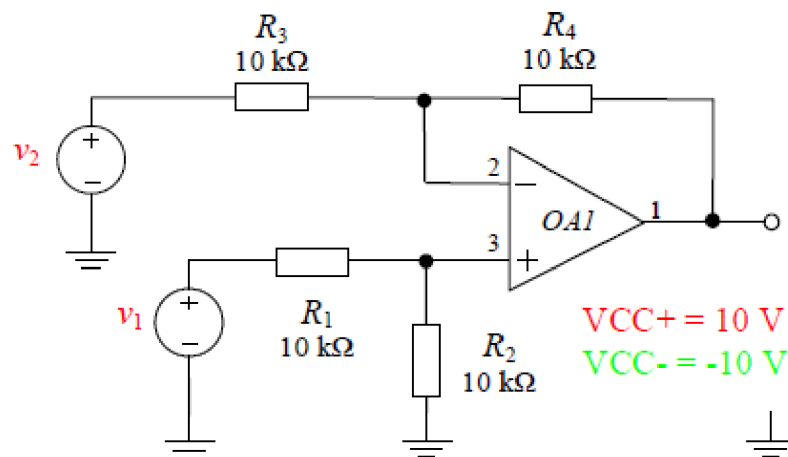

Figure 30: Connection diagram of difference amplifier

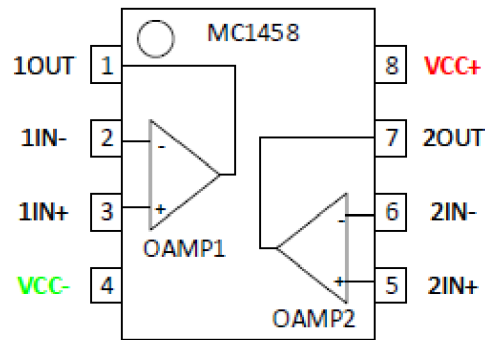

Figure 31: Integrated circuit with dual operational amplifier

At the top left corner of the integrated circuit MC1458 there is a small groove as an indication of the correct position. Obey this rule to prevent the destruction caused by the wrong polarization.

6.2.4. Working procedure

After assembling the circuit indicated in *Figure 29* and *30*. and before connecting it to the main power supply, always let the teacher check the correctness of the connection to prevent any material damage and to prevent any injury.

- a) Check the workplace if all equipment is in proper condition and if not, inform the teacher.
- b) Turn on the electronic devices (the generator, the power source and the oscilloscope) to let them stabilize before connecting any cables. If the power source previously has not been lowered down, do it immediately.
- c) Assemble the circuit according to the diagram in *Figure 29*. Be careful about the polarization of the operational amplifier.
- d) Connect one channel of the oscilloscope to the input of the amplifier and one at the output of the circuit to see the resulting signal. Only one of them needs to be connected to the ground.

- e) Set the requested values on the generator and connect the coaxial cable from the output to the connection board. $V_{p-p} = 10 \text{ V}$, $f = 1 \text{ kHz}$, *sinusoidal waveform*. A LED diode is under the button “output” which indicates if the signal is generated.
- f) Connect power supply wires (red, blue and green) as follows: green to the left “-”, blue to the center right “-”, and red to the right “+”. Then on both displays set the values of 10 V. The button “A+B” which has a red indication LED diode has to be turn on which indicates that the desired signal is on the output.
- g) By using the oscilloscope verify that the output signal is inverted sum of the input signal.
- h) Disconnect everything and proceed to the *Task 2*. Connect the circuit with the same values on the devices as in *Task 1*.
- i) Now the output of the circuit should be zero.
- j) Lower down to zero all the values on devices and disconnect the cables and clean the workspace.

6.2.5. Workplace equipment

Laboratory source Diametral L240R51D with wires

Connection board

Set of black and red wires to use on the connection board

Integrated circuit MC1458 (Dual operational amplifier) – only one will be used at a time

Oscilloscope Rigol MSO1074 and two coaxial cables

Generator Agilent 33210A and coaxial cable

6.3. “Astable multivibrator” manual

6.3.1. Objectives

Assemble two different generators according to the connection diagrams. Use the oscilloscope to see resulting signals. In *Task 1* an astable multivibrator will be created, which will produce an inverted square signal. Two LEDs demonstrate the signal change by flashing. Try to change the value of the variable resistor and different capacitors to see what happens to the LEDs. In *Task 2* do the same while creating a generator of a triangular waveform.

6.3.2. Theory

Oscillators are frequently used when signal with prescribed parameters is required. The signals can be sinusoidal, square, triangular or pulse. Oscillators which create sinusoids, which are one of the most commonly used waveform, can be made of amplifiers with positive-feedback loop and RC or LC frequency-selective network. These are known as linear oscillators.

Circuits that generate square, triangle or pulse (etc.) are called nonlinear oscillators or function generators, they employ circuit building blocks known as multivibrators. There are three types of the multivibrator: the bistable (it has two stable states), the monostable (it has one stable state, in which it can remain indefinitely if undisturbed) and the astable (it has no stable states).

The Schmitt trigger or a bistable multivibrator uses positive feedback with a loop gain greater than unity to produce bistable characteristics. The bistable multivibrator has two stable states. The circuit can remain in either stable state indefinitely and moves to the other stable state only when appropriately triggered. The bistable multivibrator is used in oscillators to create square-wave signal, which is accomplished by adding RC network to the negative feedback.

To create a triangular waveform an integrator is connected at the output of the bistable multivibrator. The integrator causes linear charging and discharging of the capacitor, thus providing a triangular waveform.

6.3.3. Connection diagram

Task 1: Astable multivibrator – generation of square waveform

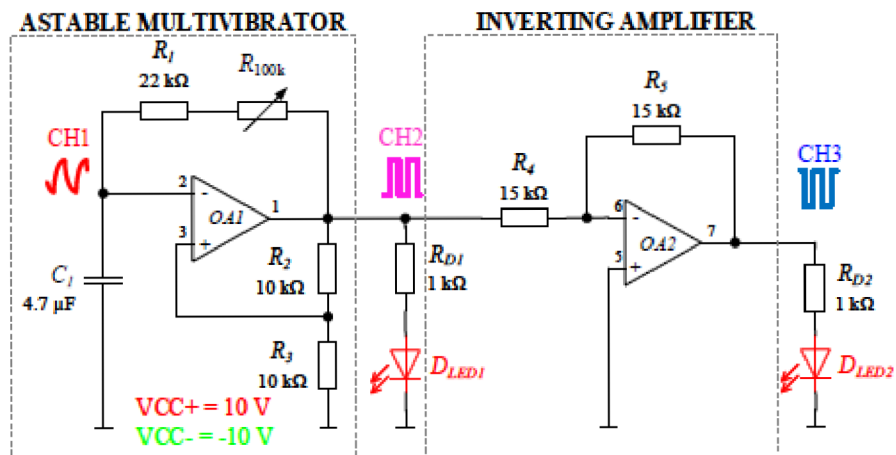

Figure 32: Connection diagram of astable multivibrator-squares

Task 2: Generation of triangular waveform

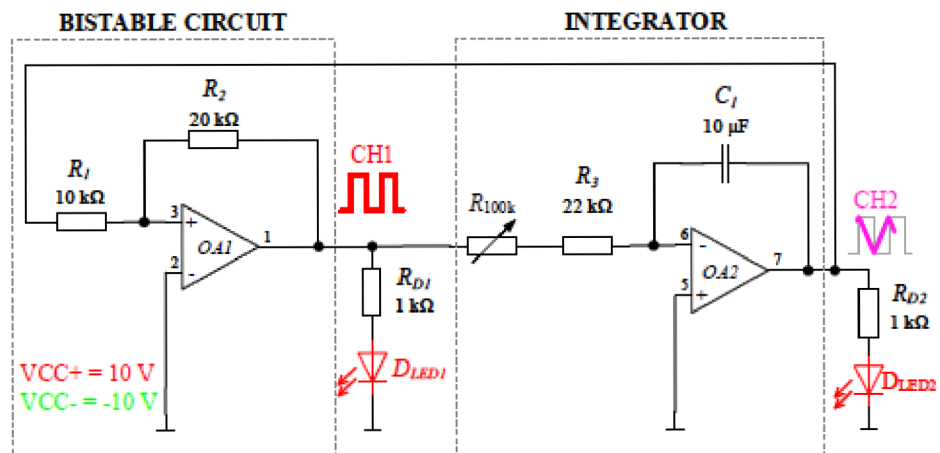

Figure 33: Connection diagram of astable multivibrator-triangles

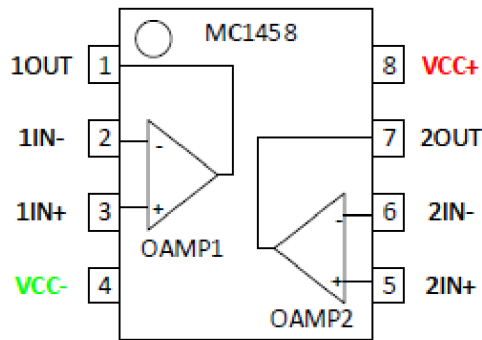

Figure 34: Integrated circuit with dual operational amplifier

At the top left corner of the integrated circuit MC1458 there is a small groove as an indication of the correct position. Obey this rule to prevent the destruction caused by the wrong polarization. The other variation is a semicircle in the center.

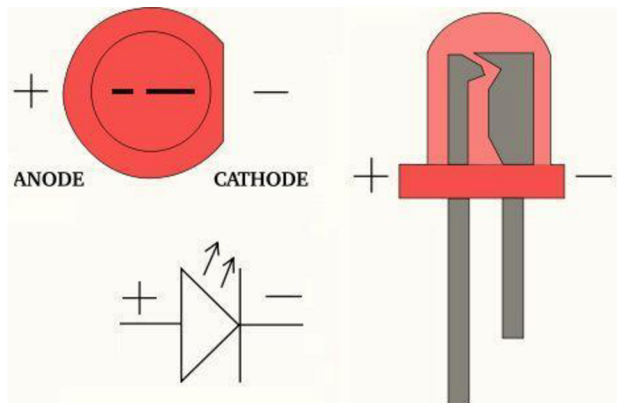

Figure 35: Connection of LED

(Retrieved from: <https://www.instructables.com/workshop/>)

6.3.4. Working procedure

Assemble the circuit according to *Figure 32*. When finished connecting, do not connect the power source cables before letting the teacher check the correctness to prevent material damage and to prevent any injury.

- a) Check the workplace if everything is in proper condition and if not, immediately inform the teacher.
- b) Turn on the oscilloscope and the power source to give them time to stabilize before connecting any cables. If the power source has not been lowered down to zero, do it before connecting any wires.
- c) Assemble the circuit according to *Figure 32 Task 1*. Divide the connecting process into smaller steps to prevent any confusion. Use different colors of wires for better clarity.
- d) Connect three channels of oscilloscope, while only one needs to be connected to the ground.
- e) Connect power supply wires (red, blue and green) as follows: green to the left “-“, blue to the center right “-“, and red to the right “+“. Then set values of 10V on both displays. The button “A+B” has an indication LED diode which has to be turned on to indicate the desired values on the output.
- f) Try changing the frequency of LED flashing by changing the resistance on variable resistor and by changing capacitor values.
- g) After demonstrating to the teacher, proceed to *Task 2* while still obeying connection rules as in *Task 1*.
- h) Try to change the frequency and see what happens.
- i) Lower down the value on devices to zero and disconnect all cables and clean the workspace.

6.3.5. Workplace equipment

Oscilloscope Rigol MSO1074 and three coaxial cables

Laboratory source Diametral L240R51D with wires (blue, red and green)

Connection board

Set of black and red wires to use on the connection board

Integrated circuit MC1458 (Dual operational amplifier)

Two LED diodes

6.4. “Simple DC source” manual

6.4.1. Objectives

Assemble a simple DC source according to the connection diagram. At three different steps of the source (“Half-wave rectifier”, input of “Linear series regulator” as well as its output) by using an oscilloscope verify the correctness of the connection by displaying the signal with each channel. Using measured values calculate the ripple factor, the line regulation and the load regulation. Try to change the value of variable resistors in a linear series regulator to see if something happens and explain why. In the remaining time try to assemble a full-wave rectifier as *Task 2*.

6.4.2. Theory

A rectifier circuit converts an alternating (AC) voltage into one that is limited to one polarity. The diode is useful for this function because of its nonlinear characteristics, meaning that the current flows for one voltage polarity, but is essentially zero for the opposite polarity. The rectification is classified as half-wave or full-wave, with half-wave

being the simpler and full-wave being more efficient. A capacitor connected to the ground behind the rectification diode works as a filter, which reduces the input ripple to the regulator at an acceptable level.

A voltage regulator is connected to the output of a filtered rectifier and maintains a constant output voltage despite changes in the input, the load current or the temperature. The fundamental classes of voltage regulators are linear regulators and switching regulators. Two basic types of linear regulator are the series regulator and shunt regulator.

The control element of a regulator is a transistor, the output sample circuit (resistive voltage divider) senses a change in the output voltage. The error detector (operational amplifier – op amp) compares the sample voltage with a reference voltage and causes the control element to maintain a constant output voltage.

The ripple factor (r) is an indication of the effectiveness of the filter. The lower the ripple factor, the better the filter. The ripple factor can be lowered by increasing the value of the filter capacitor or increasing the load resistance:

$$r = \frac{V_{r(p-p)}}{V_{DC}} = \frac{V_{reg,in(p-p)}}{V_{reg,inDC}}, \quad (13)$$

where $V_{reg,in(p-p)}$ is the voltage of peak-to-peak value of a rectified and filtered signal at the input (CH2) and $V_{reg,inDC}$ is the average value of the input signal (CH2).

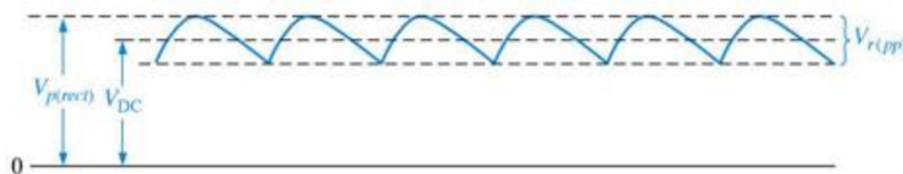

Figure 36: Ripple factor

(Retrieved from: <https://electronics.stackexchange.com/>)

Line regulation can be defined as the percentage change in the output voltage for a given change in the input voltage:

$$LinReg = \frac{\Delta V_{OUT}}{\Delta V_{IN}} = \frac{V_{reg,out(p-p)}}{V_{reg,in(p-p)}} * 100\%, \quad (14)$$

where $V_{reg,out(p-p)}$ is the voltage of peak-to-peak value of regulated signal at the output (CH3) and $V_{reg,in(p-p)}$ is the voltage of peak-to-peak value of rectified and filtered signal at the input (CH2).

Meanwhile the load regulation is defined as the percentage change in the output voltage for a given change on load current:

$$LoadReg = \frac{V_{NL}-V_{FL}}{V_{FL}} = \frac{V_{reg,out(\infty)}-V_{reg,out(560)}}{V_{reg,out(560)}} * 100\%, \quad (15)$$

where $V_{reg,out(\infty)}$ is the average voltage at the output (CH3) without anything as the load (\approx infinite resistance) and $V_{reg,out(560)}$ is the average voltage at the output (CH3) when the load $R = 560 \Omega$ is connected.

To obtain peak-to-peak value, the “*Measure*” mode on the oscilloscope can be used as well as cursors. The average value can be calculated or obtained also by “*Measure*” feature.

6.4.3. Connection diagram

Task 1: Simple DC source with half-wave rectifier

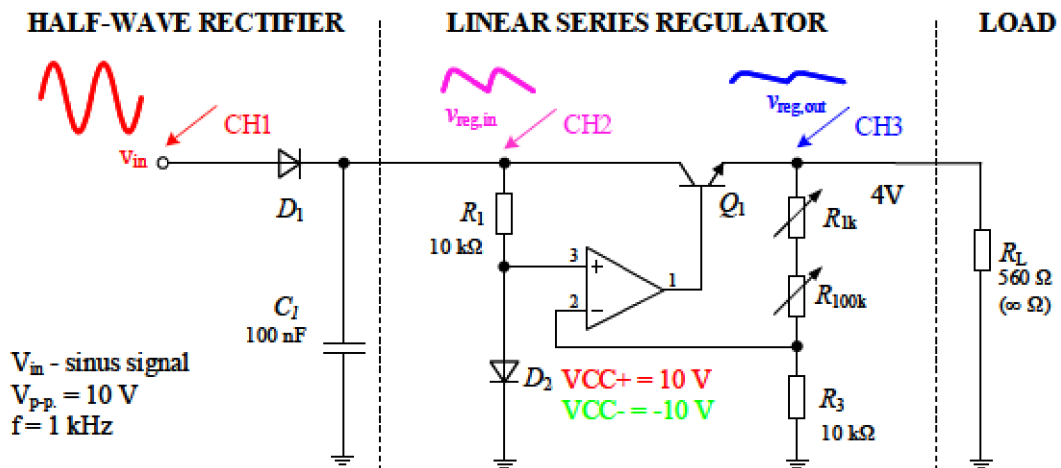

Figure 37: Connection diagram of a simple DC source

Task 2: Full-wave rectifier

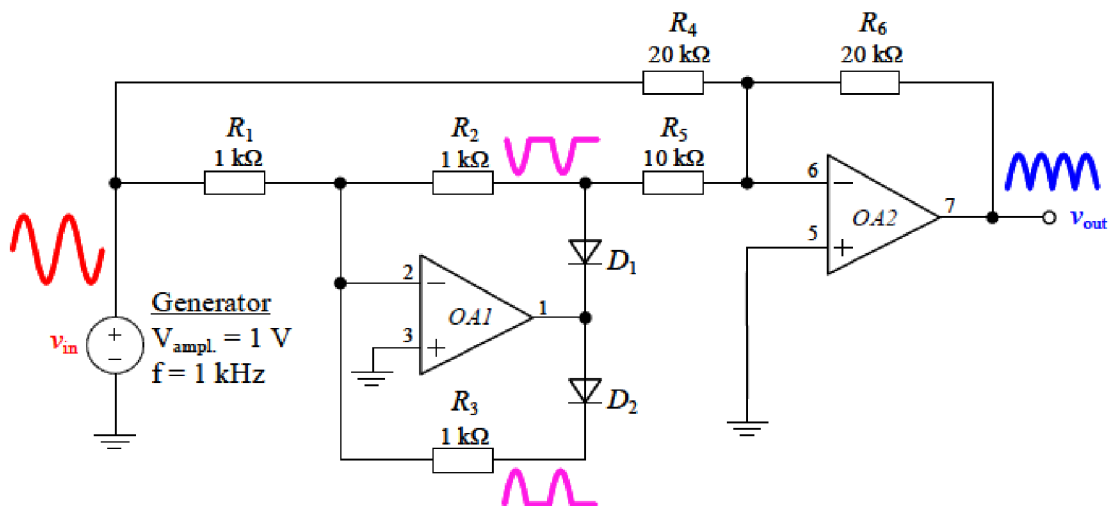

Figure 38: Connection diagram of a full-wave rectifier

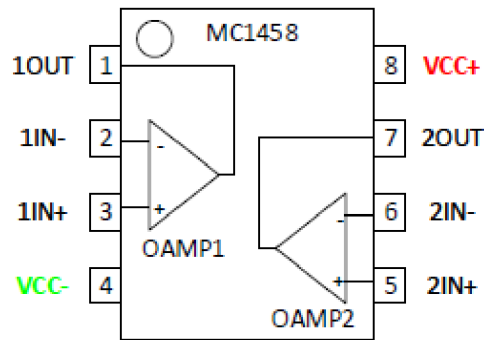

Figure 39: Integrated circuit with dual operational amplifier

To prevent destroying the integrated circuit by the wrong polarization there is a small groove in the shape of a circle at the top left corner (See Figure 39.) as an indication of the correct position. The other variation is a semicircle in the center.

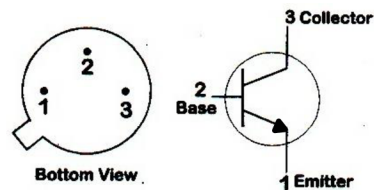

Figure 40: Schematic diagram of a transistor (bottom view)
(Retrieved from: <https://artsandscience.usask.ca/physics/>)

6.4.4. Working procedure

After assembling the circuit indicated in Figure 37. and before connecting it to the main supply, always let the teacher check the correctness to prevent any material damage and to prevent any injury.

- a) Check the workplace if everything is in proper condition and if not, immediately inform the teacher.

- b) Turn on the devices (the oscilloscope, the generator and the power source) to let them stabilize without connecting any cables. If the power source has not been lowered down previously, do it before connecting any wires.
- c) Assemble the circuit according to the circuit diagram *Figure 37*. Try to divide the connection process into steps to prevent mistakes caused by confusing connecting. D_1 , C_1 , R_1 and D_2 should be connected first and then the rest. Use different colours of cables for better clarity.
- d) Connect three channels of the oscilloscope at each step of the DC source (See *Figure 37*). Only one of these needs to be connected to the ground.
- e) Set the requested values on the generator and connect the coaxial cable from the output to the connection board. $V_{p-p} = 10\text{ V}$, $f = 1\text{ kHz}$, *sinusoidal waveform*. Check if the output impedance is set correctly: *Utility – Output setup – High Z*. A LED diode is under the button “output” which indicates if the desired signal is generated.
- f) Connect power supply wires (red, blue and green) as follows: green to the left “-“, blue to the center right “-“, and red to the right “+“. Then set values of 10 V on both displays. A button “A+B” has an indication LED diode. If the LED is lit, it indicates that the output is ON.
- g) Use the feature “Measure” of the oscilloscope to obtain the average and peak-to-peak values and calculate the ripple factor, the line regulation and the load regulation.
- h) If all the values are calculated, assemble a full-wave rectifier according to *Figure 38*. and observe the output signal of this circuit.
- i) Lower down the values on devices to zero and disconnect all cables and clean the workspace.

6.4.5. Workplace equipment

Oscilloscope Rigol MSO1074 and three coaxial cables

Generator Agilent 33210A and coaxial cable

Laboratory source Diametral L240R51D with wires (blue, red and green)

Connection board

Set of black and red wires to use on the connection board

Transistor

Integrated circuit MC1458 (Dual operational amplifier)

6.4.6. Measured values

Table 1. Ripple factor

$V_{reg,in(p-p)}$ [V]	$V_{reg,inDC}$ [V]	r [-]

The smaller the ripple the better, the value should be below 1 for DC power supply to work properly.

Table 2. Line regulation

$V_{reg,out(p-p)}$ [V]	$V_{reg,in(p-p)}$ [V]	$LinReg$ [-]

The line regulation is a variable without a distinctive unit. To obtain the result in percentage we need to multiply the resulting number by 100 which in this case should be around 10 %.

Table 3. Load regulation

$V_{reg,out(\infty)}$ [V]	$V_{reg,in(560)}$ [V]	$LoadReg$ [-]

The load regulation, again, will be represented by percentage value.

Show the calculated values to the teacher to successfully complete this laboratory exercise.

7. CONCLUSION

The electronics, as a matter of fact, is a broad topic, especially nowadays when reducing the dimensions of products while keeping the same efficiency or even raising them is often demanded. In this thesis, in the first part, each of the theory topic was discussed enough for students of study program “Electrical Engineering and Informatics” to comprehend the topic and to be prepared to extend the knowledge of these topics in upcoming years of studies.

The second part includes written manuals which should work as helpful tools for students to complete successfully not just these laboratory tasks, but the whole subject Analog technology. The manuals are composed of the objectives, which students should fulfill, the short theory regarding the exercise, connection diagrams, working procedures and workplace equipment which is needed. The thoroughly written working procedures should help to navigate through the process of measuring in order to reach the required outcome without damaging laboratory devices (transistors and operational amplifiers) mostly because of the wrong polarization. Comprehensible manuals should also speed the laboratory exercises, maybe enough to complete or at least acquaint with other phenomena regarding given topic. In some manuals there is an optional “Task 2”, which students were not able to finish due to the lack of time, hence the manuals which should solve this problem and provide all students with the same practice with different phenomena.

This bachelor thesis is a sequel to my semester thesis which contained part of the “DC source” manual which is now extended by an additional task regarding full-wave rectifier. On top of that, there are further three more manuals of different topics from the course curriculum. One of them (“Difference and summing operational amplifier”) was newly introduced to complete laboratory tasks to the maximum. Before this new laboratory exercise, the topic of operational amplifiers was discussed at lectures, but there was no laboratory task regarding operational amplifiers and its configurations. Therefore, every topic included in the curriculum is discussed at lectures and each of the topic now has related laboratory exercise, also with a manual for students. Together with the fact that these four topics are also a state exam questions, I hope that my contribution will help to all who will

choose the subject Analog technology in state exams. Hopefully, there will be a possibility to implement these manuals soon to see how they work real life and how much it helps.

Generally speaking, the aim of all manuals is to enhance the level of knowledge of all students attending the course, which should also help them in the future, and to make space for the future development of the course.

8. ROZŠÍŘENÝ ABSTRAKT

Studijní obor Angličtina v elektrotechnice a informatice je jeden z mnoha perspektivních bakalářských programů, které Fakulta elektrotechniky a komunikačních technologií Vysokého učení technického v Brně pro studenty nabízí. Tento však jako jediný z nich kombinuje studium jazyka, konkrétně anglického, a výuku elektrotechnických odborných předmětů. V podstatě přesně pokrývá potřeby dnešní doby tak, aby absolventi uměli plyně hovořit anglicky a zároveň měli přehled o elektrotechnice, které nás obklopuje každým rokem více a více. Jedině tato kombinace znalosti jazyka a odbornost dává absolventům velkou šanci na trhu práce a možnost uplatnění se v zahraničí či u mezinárodních firem.

Tato práce se zaměřuje na jeden z předmětů, již zmiňovaného oboru, a to na předmět Analogová technika vyučovaný ve druhém roce, v zimním semestru. Tento předmět navazuje a dále rozšiřuje poznatky získané v předmětech předchozích semestrů. Zejména se však zaměřuje na konkrétní aplikace a realizace vybraných lineárních a nelineárních funkčních bloků. Věnuje se různým typům operačních zesilovačů a seznamuje i s ostatními druhy aktivních prvků využívaných v moderním světě a současné technice. Předmět se skládá z přednášek a povinných laboratorních cvičení, ve kterých si studenti mohou prakticky vyzkoušet právě probíranou látku. V laboratorních cvičeních studenti vždy ve dvojicích řeší a snaží se splnit daný úkol. Jednotlivá stávající zadání jsou čtyři:

- Seznámení s pracovištěm + napěťový dělič, blikání LED diody jako zátěž.
- Tranzistorový zesilovač v zapojení společného emitoru a nastavení pracovního bodu.
- Astabilní multivibrátor.
- Stejnoseměrný zdroj.

Jako výstup jednotlivých úloh je buď předvedení požadovaného jevu učiteli nebo představení vypočítaných výsledných hodnot.

V první části této práce je probrána teorie týkající se všech laboratorních úloh, s výjimkou úlohy první, kdy se studenti seznamují s pracovištěm, jeho vybavením a jsou také poučeni

o bezpečnosti práce v laboratořích a součástí je i zopakování teorie zakončené zapojením napěťového děliče. Tedy kromě tranzistorových zesilovačů, oscilátorů a stejnosměrných zdrojů se nachází v první části i kapitola týkající se operačních zesilovačů. Tímto se tak pokryje celá teorie probíraná na přednáškách a uvede studenta i do dané problematiky před následující druhou částí této práce, kde budou představeny návody pro následující laboratorní cvičení: tři stávající úlohy a jednu novou úlohu, která se bude zabývat právě operačními zesilovači. Tímto bude kompletně pokryta výuka na přednáškách a v laboratorních cvičení. Každé z teoreticky probíraných témat, tak bude mít i svou vlastní laboratorní úlohu. Hlavním důvodem mého výběru tohoto zadání je nejen můj zájem o předmět Analogová technika, ale i možnost, jak tento předmět na základě mých nabytých zkušeností inovovat a umožnit všem novým studentům přicházejících z různých typů středních škol s různou úrovní odborného vzdělání úspěšně zvládnout a pochopit nejen všechny úlohy, ale i celý předmět Analogová technika.

Jednotlivé manuály pro laboratorní cvičení se skládají z pěti základních kapitol. První kapitola vždy obsahuje úkoly, které dvojice studentů musí splnit, aby úspěšně absolvovali dané laboratorní cvičení. Například se jedná o správně vykreslený signál na osciloskopu či naměření požadovaných hodnot. Po zadání obsaženém v první kapitole, následuje přiblížení teorie k stanovené úloze, aby si studenti zopakovali dané téma a měli tak přehled o tom, co budou zapojovat a měřit. Třetí kapitola představuje zapojovací schéma se všemi vstupními hodnotami, které budou nastaveny na zdroji či generátoru. Ve schématech studenti můžou vidět i přibližný tvar signálu v jednotlivých krocích, což by mělo metodicky napomocet a vést k úspěšnému postupu práce. Většinu zapojování studenti provádí na zapojovací desce, která je osazena odpory a kondenzátory různých hodnot, potenciometry, diodami a dalšími pasivními prvky. Následující čtvrtá kapitola, pro studenty nejdůležitější část návodu, obsahuje podrobný postup práce, který když studenti dodrží, tak spolu s použitím obsahu třetí kapitoly, splní zadání a dosáhnou požadovaného výsledku. V postupu jsou i zmíněny bezpečnostní informace a pravidla, aby se vyvarovalo zranění osob nebo poškození či zničení některé z pomůcek. Poslední pátou kapitolu tvoří seznam jednotlivých pomůcek a přístrojů, které studenti budou k vypracování dané úlohy potřebovat.

Představená nová úloha na operační zesilovače, které doplní tři hlavní stávající úlohy se skládá ze dvou úkolů:

- Sestrojení sumačního zesilovače, na jehož funkci si studenti ověří chování signálů na vstupu operačního zesilovače. Ověří si a prakticky potvrdí, že výstupní signál bude roven součtu signálů na vstupu.
- Zapojení diferenčního zesilovače. Tj. úkolem studentů je sestavit opačnou matematickou funkci pomocí diferenčního zesilovače, kde výstupní signál bude tvořen rozdílem dvou vstupních signálů. Konkrétně tady bude s největší pravděpodobností použit pouze jeden generátor, z důvodu kapacit laboratoře, takže výstupní signál by se měl rovnat nule. V ideálním případě je však nezbytné použít generátory dva a mít tak možnost nastavení odlišných signálů na vstupech operačního zesilovače, a tak si ověřit hodnoty na výstupu.

Cílem těchto podrobných návodů je umožnit všem studentům splnit požadovaná zadání a snad i úkoly dobrovolné, které v tuto dobu stíhalo jen pár studentů v důsledku rozdílných technických dovedností, které si přinesli z předchozího středoškolského studia. Dalším přínosem, který umožní, že se stihne v laboratořích více, je i to, že nyní, když některá z dvojic měla nějaký problém a učitel se jim věnoval, nebyl schopný být například u další dvojice, která se mohla také potýkat s problémy nebo mít nějaký technický dotaz. Úkolem podrobně zpracovaných manuálů je vyhnout se v co největší míře problémům při plnění úkolů a zefektivnění činnosti studentů. Součástí správné metodiky je i doporučení studentům, návody si dopředu vytisknout a přinést do laboratorních cvičení, aby mohli se svým návodem pracovat, doplňovat o poznámky a později jim mohl posloužit i jako materiál k přípravě na zkoušku.

Tyto čtyři laboratorní úlohy, které doplňují přednášky jsou také okruhy na státní závěrečnou zkoušku pro studenty, kteří si vyberou předmět Analogová technika. Takže mým cílem nebylo jen zvednout úspěšnost studentů u zkoušky, zvýšit efektivitu laboratorních cvičení a současně umožnit případným budoucím inovacím, ale i poskytnout studentům ty nejlepší podmínky a podklady pro přípravu a úspěšné zvládnutí státní závěrečné zkoušky.

9. LIST OF REFERENCES

ALEXANDER, Charles K. a Matthew N. O. SADIKU. *Fundamentals of electric circuits*. 4th ed. Boston: McGraw-Hill, c2009. ISBN 978-0-07-352955-4.

ASHBY, Darren. *Electrical engineering 101: everything you should have learned in school but probably didn't*. 3rd ed. Boston, MA: Elsevier/Newnes, c2012. ISBN 978-0-12-386001-9.

GUREVICH, Vladimir. *Power supply devices and systems of relay protection*. Boca Raton: CRC Press, [2014]. ISBN 978-146-6583-795.

HOROWITZ, Paul a Winfield HILL. *The art of electronics*. 2nd ed. New York: Cambridge University Press, 1989. ISBN 0-521-37095-7.

KANG, James S. *Electric circuits*. Mason, OH: Cengage South Western, 2016. ISBN 978-1-305-63521-0.

MALVINO, Albert Paul a David J. BATES. *Electronic principles*. Eighth edition. New York: McGraw-Hill Education, 2015. ISBN 978-0-07-337388-1.

MAXFIELD, Clive. *Electrical engineering*. Boston: Newnes/Elsevier, c2008. ISBN 978-1-85617-528-9.

MEHTA, V.K. a Rohit MEHTA. *Principles of Electronics*. Eleventh Edition. New Delhi: S. Chand & Company, 2008. ISBN 81-219-2450-2.

SCHERZ, Paul a Simon MONK. *Practical electronics for inventors*. Fourth Edition. New York: McGraw-Hill Education, [2016]. ISBN 978-1-25-958754-2.

SCHUBERT, JR., Thomas F. a Ernest M. KIM. *Fundamentals of Electronics: Book 4: Oscillators and Advanced Electronics Topics*. University of San Diego: Morgan & Claypool Publishers, 2016. ISBN 9781627055680.

SCHULTZ, Mitchel E. a Bernard GROB. *Grob's basic electronics*. 11th ed. New York, NY: McGraw-Hill, c2011. ISBN 978-0-07-351085-9.

9.1. Online sources

Filter Circuits. In: *CircuitsToday* [online]. 14. 8. 2018 [cit. 2019-12-13]. Retrieved from: <http://www.circuitstoday.com/filter-circuits>

Full Wave Rectifier. In: *ElectronicsTutorials* [online]. Portland: AspenCore [cit. 2019-12-04]. Retrieved from: https://www.electronics-tutorials.ws/diode/diode_6.html

10. LIST OF FIGURES

Figure 1	Bipolar transistors
Figure 2	CB, CE, CC
Figure 3	Common-emitter configuration
Figure 4	Common-base configuration
Figure 5	Common-collector configuration
Figure 6	Circuit symbol of op amp with power terminals
Figure 7	Ideal op amp
Figure 8	Inverting op amp
Figure 9	Noninverting op amp
Figure 10	Voltage follower
Figure 11	Difference amplifier
Figure 12	Summing amplifier
Figure 13	Linear oscillator
Figure 14	Phase-shift oscillator
Figure 15	Noninverting Schmitt trigger oscillator
Figure 16	Astable multivibrator
Figure 17	Monostable multivibrator
Figure 18	DC power source
Figure 19	V-I Characteristic of a diode

Figure 20	Half-wave rectifier circuit
Figure 21	Half-wave rectified signal
Figure 22	Full-wave rectifier circuit and output signal
Figure 23	Full-wave bridge rectifier circuit
Figure 24	Capacitor-input filter circuit
Figure 25	Filtered signal by capacitor
Figure 26	Voltage regulator
Figure 27	Connection diagram of transistor amplifier CE
Figure 28	Schematic diagram of a transistor (bottom view)
Figure 29	Connection diagram of summing amplifier
Figure 30	Connection diagram of difference amplifier
Figure 31	Integrated circuit with dual operational amplifier
Figure 32	Connection diagram of astable multivibrator - squares
Figure 33	Connection diagram of astable multivibrator - triangles
Figure 34	Integrated circuit with dual operational amplifier
Figure 35	Connection of LED
Figure 36	Ripple factor
Figure 37	Connection diagram of a simple DC source
Figure 38	Connection diagram of a full-wave rectifier
Figure 39	Integrated circuit with dual operational amplifier

Figure 40 Schematic diagram of a transistor (bottom view)

11. LIST OF TABLES

- Table 1. Ripple factor
- Table 2. Line regulation
- Table 3. Load regulation