

VYSOKÉ UČENÍ TECHNICKÉ V BRNĚ

BRNO UNIVERSITY OF TECHNOLOGY

FAKULTA STAVEBNÍ
ÚSTAV POZEMNÍHO STAVITELSTVÍ

FACULTY OF CIVIL ENGINEERING
INSTITUTE OF BUILDING STRUCTURES

LOW ENERGY BLOCK OF APARTMENTS

DIPLOMOVÁ PRÁCE
DIPLOMA THESIS

AUTOR PRÁCE
AUTHOR

BC. MARIAN HLAVICA

BRNO 2014

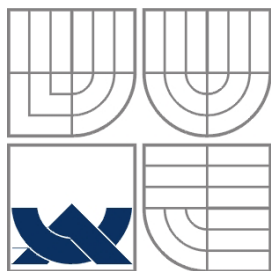

VYSOKÉ UČENÍ TECHNICKÉ V BRNĚ

BRNO UNIVERSITY OF TECHNOLOGY



FAKULTA STAVEBNÍ

ÚSTAV POZEMNÍHO STAVITELSTVÍ

FACULTY OF CIVIL ENGINEERING
INSTITUTE OF BUILDING STRUCTURES

0 – BASIC DOCUMENTS

DIPLOMOVÁ PRÁCE

MASTER'S THESIS

AUTOR PRÁCE

AUTHOR

BC. MARIAN HLAVICA

VEDOUCÍ PRÁCE

SUPERVISOR

doc. Ing. JIŘÍ SEDLÁK, CSc.

BRNO 2014

0 – Basic documents

- Title page
- Task definition
- Abstract
- Bibliographic quotation
- Declaration of origin of the thesis
- Declaration of identic electronic and paper version
- Thanks
- Content of folders
- Introduction
- Conclusion
- List of used information sources
- List of annexes



VYSOKÉ UČENÍ TECHNICKÉ V BRNĚ
BRNO UNIVERSITY OF TECHNOLOGY

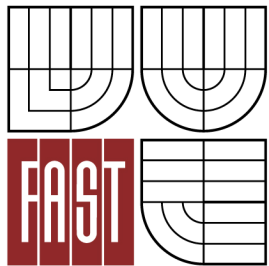

FAKULTA STAVEBNÍ
ÚSTAV POZEMNÍHO STAVITELSTVÍ

FACULTY OF CIVIL ENGINEERING
INSTITUTE OF BUILDING STRUCTURES

LOW ENERGY BLOCK OF APARTMENTS

LOW ENERGY BLOCK OF APARTMENTS

DIPLOMOVÁ PRÁCE
DIPLOMA THESIS

AUTOR PRÁCE
AUTHOR

BC. MARIAN HLAVICA

VEDOUČÍ PRÁCE
SUPERVISOR

doc. Ing. JIŘÍ SEDLÁK, CSc.

BRNO 2014



VYSOKÉ UČENÍ TECHNICKÉ V BRNĚ FAKULTA STAVEBNÍ

Studijní program	N3607 Civil Engineering
Typ studijního programu	Navazující magisterský studijní program s výukou v anglickém jazyce s přesunutí formou studia
Studijní obor	3608T001 Pozemní stavby
Pracoviště	Ústav pozemního stavitelství

ZADÁNÍ DIPLOMOVÉ PRÁCE

Diplomant	Bc. Marian Hlavica
Název	Low energy block of apartments
Vedoucí diplomové práce	doc. Ing. Jiří Sedlák, CSc.
Datum zadání diplomové práce	31. 3. 2013
Datum odevzdání diplomové práce	17. 1. 2014
V Brně dne 31. 3. 2013	

.....
prof. Ing. Miloslav Novotný, CSc.
Vedoucí ústavu

.....
prof. Ing. Rostislav Drochytka, CSc., MBA
Díkan Fakulty stavební VUT

Podklady a literatura

Study disposition of the building, catalogues and technical literature, Act No. 183/2006, Coll., Act No. 350/2012, Notice No. 499/2006 Coll., Notice 268/2009 Coll., Notice 398/2009 Coll. Valid CSN and National EN ISO standard, the Dean directive No. 19/2011 and amendments.

Zásady pro vypracování

Entering the thesis VŠKP: Engineering design of building for construction of low energy block of apartments.

Objective of thesis: To solve the layout for a particular purpose, design of appropriate building system and load bearing structure, development of design documentation, including the text and attachments according to the requirements of supervisor. Text and drawing documentation will be processed in selected graphic editor by computer. Drawings will be provided with a uniform inscription field and for the defence will be submitted to a board composed of stiff paper coated with a black screen with a prescribed description with gold lettering. Subfolders A4 will be provided with inscription field listing the attachments inside the folder.

Desired outcomes according to the Directive:

The text part of thesis VŠKP will include, amongst other items also item h) Introduction (description of the subject to enter thesis VŠKP), item i) The actual text of the work (project documentation, Item F - Technical report according to the Notice No. 499/2006 Coll.) and item j) Conclusion (evaluation of VŠKP content, compliance with the entering, changes compared to the original study).

Annex text of thesis will include technical report if the thesis is a constructive project, it will be mandatory and will include drawings for building construction (technical situation, foundations, floor plans solved, roofing structure, vertical sections, elevations, details, assembly plan of components, drawings of floor structures, technical specification, tables of building compositions - the extent of thesis will be determined by supervisor), report of fire safety, building physics assessment of constructions, engineering specialization of given topic. The specialization will be decided by the supervisor during the students work

Pøedepsané pøílohy

.....
doc. Ing. Jiøí Sedlák, CSc.
Vedoucí diplomové práce

Abstrakt

Cílem práce bylo vypracování projektové dokumentace pro stavbu: Nízkoenergetický bytový dům. Dokumentace byla zpracována ve stupni pro realizaci stavby. Jedná se o čtyřpodlažní bytový dům s plochou nevětranou střechou a částečně podzemní hromadnou garáží. Stavba je navržena se zvýšenými nároky na tepelné vlastnosti objektu. Projekt dále řeší studii vytápění. Její energetická náročnost byla ověřena pomocí podrobného výpočtu dle ČSN 73 0540 a zpracovaného průkazu energetické náročnosti budovy. Výsledná energetická náročnost stavby je B – velmi úsporná.

Klíčová slova

nízkoenergetický bytový dům plochá nevětraná střecha hromadná garáž studie vytápění

Abstract

The goal of the project is development of a project documentation for a building: Low energy block of apartments. The documentation was processed in the degree for construction realization. It solves a four floor block of apartments with flat warm roof and partially depressed parking garage. The structure is designed with risen requirements on thermal properties. The project also solves a concept of heating system. Its energy efficiency was analysed using precise calculation acc. ČSN 73 0540 and processed statement of energy efficiency. The result energy consumption of the structure is B – very efficient.

Keywords

low energy block of apartments flat warm room parking garage heating system concept

...

Bibliografická citace VŠKP

Bc. Marian Hlavica *Low energy block of apartments*. Brno, 2014. 281 s., 5 s. příl. Diplomová práce. Vysoké učení technické v Brně, Fakulta stavební, Ústav pozemního stavitelství.
Vedoucí práce doc. Ing. Jiří Sedlák, CSc..

Prohlášení:

Prohlašuji, že jsem diplomovou práci zpracoval(a) samostatně a že jsem uvedl(a) všechny použité informační zdroje.

V Brně dne 16.1.2014

.....
podpis autora
Bc. Marian Hlavica

PROHLÁŠENÍ O SHODĚ LISTINNÉ A ELEKTRONICKÉ FORMY VŠKP

Prohlášení:

Prohlašuji, že elektronická forma odevzdané diplomové práce je shodná s odevzdanou listinnou formou.

V Brně dne 16.1.2014

.....
podpis autora
Bc. Marian Hlavica

Thanks:

I would like to thank my supervisor of the master's thesis doc. Jiří Sedlák, CSc. for proper leading and supervision; patience and helpful advices during consultation.

Poděkování:

Tímto bych rád poděkoval vedoucímu diplomové práce doc. Jiřímu Sedlákovi, CSc. za patřičné vedení, trpělivost a užitečné rady během konzultací.

CONTENT OF THE MASTER'S THESIS DOCUMENTATION

0 – Basic documents

- Title page
- Task definition
- Abstract
- Bibliographic quotation
- Declaration of origin of the thesis
- Declaration of identic electronic and paper version
- Thanks
- Content of folders
- Introduction
- Conclusion
- List of used information sources
- List of annexes

A - Accompanying report

B – Summary technical report

C – Situations

- C.1 – Situation of further relations
- C.2 – Overall situation
- C.3 – Controlling situation

D.1 – Documentation of structures

D.1.1 – Architectonic – construction solution

D.1.1 Technical report

D.1.1 Drawings

- D.1.1-01 – Architectonic concept – Layout of 1st undg.floor
- D.1.1-02 – Architectonic concept – Layout of 1st floor
- D.1.1-03 – Architectonic concept – Layout of 2nd floor
- D.1.1-04 – Architectonic concept – Layout of 3rd floor
- D.1.1-05 – Layout of foundations
- D.1.1-06 – Layout of 1st undg. floor
- D.1.1-07 – Layout of 1st floor
- D.1.1-08 – Layout of 2nd floor
- D.1.1-09 – Layout of 3rd floor

- D.1.1-10 – Roof
- D.1.1-11 – Sectional elevation A-A'
- D.1.1-12 – Sectional elevation B-B'
- D.1.1-13 – Ceiling construction above 1st undg. floor
- D.1.1-14 – Ceiling construction above 1st floor
- D.1.1-15 – Ceiling construction above 2nd floor
- D.1.1-16 – Ceiling construction above 3rd floor
- D.1.1-17 – Southern elevation
- D.1.1-18 – Western elevation
- D.1.1-19 – Northern elevation
- D.1.1-20 – Eastern elevation

D.1.1 Documentation of particularities

- D.1.1-21 – Detail of roof edge
- D.1.1-22 – Detail of balcony slab
- D.1.1-23 – Detail of elevator shaft
- D.1.1-24 – Detail of roof inlet
- D.1.1-25 – Detail of window lintel
- D.1.1-26 – Detail of stair flight connection
- D.1.1-27 – Detail of roof access
- D.1.1-28 – Detail of window sill
- D.1.1-29 – List of windows
- D.1.1-30 – List of doors
- D.1.1-31 – List of lintels
- D.1.1-32 – List of tinsmith products
- D.1.1-33 – List of locksmith products
- D.1.1-34 – List of compositions
- D.1.1-35 – List of floor compositions

D.1.2 – Technical – construction solution – NOT SOLVED

D.1.3 – Fire safety solution

D.1.3 Technical report

D.1.3 Drawings

- D.1.3-01 – Fire safety situation
- D.1.3-02 - Layout of 1st undg. floor
- D.1.3-03 – Layout of 1st floor
- D.1.3-04 – Layout of 2nd floor
- D.1.3-05 – Layout of 3rd floor

D.1.4 Building environment technics

D.1.4.1 Heating system concept

D.1.4.1 Technical report

D.1.4.1 Drawings

- D.1.4.1-01 – Layout of typical floor
- D.1.4.1-02 – Scheme of riser R1
- D.1.4.1-03 – Scheme of riser R2
- D.1.4.1-04 – Scheme of riser R3
- D.1.4.1-05 – Scheme of riser R4

D.1.4.1 List of machinery

E - Other documents

- E.1 – Statement of energy efficiency
- E.2 – Energy label
- E.3 – Geological survey
- E.4 - Calculations

Úvod:

Zadáním práce bylo vypracovat realizační dokumentaci pro stavbu: Nízkoenergetický bytový dům. Téma bylo postupně zpracováno a výsledkem měla být dokumentace v přílohách této diplomové práce. Bylo potřeba vyhodnotit energetické vlastnosti budovy, které byly optimalizovány s cílem snížit celkovou potřebu tepla na vytápění v budově.

Vlastnosti budovy byly hodnoceny pomocí metod předepsaných zákonem a podle platných ČSN.

V dokumentaci byla dále zpracována specializace, jejímž předmětem bylo vytvoření studie vytápění řešeného objektu.

Intorduction:

The goal of this master's thesis was to create a realization documentation for a building: Low energy block of apartments. The theme has been continuously processed and the result was supposed to be the documentation in the annex of this thesis. It was aimed to evaluate energetic properties of the structure which were optimalsed to lower the overall heat consumption.

The properties of the building were evaluated using methods prescribed by law and by valid ČSN.

The documentation also sloves specialization with objective was to create a concept of heating systém.

Závěr:

Výsledkem této práce je realizační dokumentace pro stavbu: Nízkoenergetický bytový dům. Dům byl zhodnocen z hlediska potřeb tepla a tepelné ztráty a byl zařazen do kategorie B – velmi úsporný.

Vlastnosti budovy byly hodnoceny pomocí metod předepsaných zákonem a podle platných ČSN.

Výsledkem specializace je návrh otopného systému a zdroje tepla.

Conclusion

The result of this thesis is a realization documentation for a building: Low energy block of apartments. The house has been evaluated regarding the heat demands and heat losses and has been categorized as B – very efficient.

The properties of the building were evaluated using methods prescribed by law and by valid ČSN.

The result of the specialization is a design of heating system and a heat source.

Used legislation (požité právní předpisy):

- Law no. 183/2006 Sb., o územním plánování a stavebním řádu.
- Vyhláška MV č. 246/2001 Sb., o stanovení podmínek požární bezpečnosti a výkonu státního požárního dozoru.
- Vyhláška č. 137/1996 Sb., o obecných technických požadavcích na výstavbu
- Vyhláška č. 63/2013 Sb., o dokumentaci staveb

Použité ČSN (used standards):

- ČSN 73 4301 – Residential buildings
- ČSN 73 6056 – Parking areas for road vehicles
- ČSN 73 6058 – Small, multi-storey and mass garages
- ČSN 73 0540-2 – Thermal protection of buildings, requirements
- ČSN 73 0540-3 – Thermal protection of buildings, design value quantities
- ČSN 73 0818 – Fire protection of buildings – person/surface rate in buildings
- ČSN 73 0833 – Fire protection of buildings – buildings for dwelling and lodging
- ČSN 73 6110 – Design of urban roads
- ČSN EN 12 831 - Heating systems in buildings - Method for calculation of the design heat load
- ČSN 06 0210 - Calculation of heat losses in building with central heating
- ČSN 01 3452 - Technical drawings - Installations - Heating and refrigerating systems
- ČSN 73 4201 - Chimneys and connecting flue pipes - Design, construction and installation of heating appliances
- ČSN 01 3420 - Construction drawings - Presentation of general arrangement drawings
- Other ČSN

Webové stránky výrobců a dodavatelů (web sites of manufacturers and suppliers)

www.katalog.betonservis.cz

www.ytong.cz

www.isover.cz

www.cemix.cz

www.slavona.cz

LIST OF ANNEXES

A - Accompanying report

B – Summary technical report

C – Situations

D.1 – Documentation of structures

E - Other documents

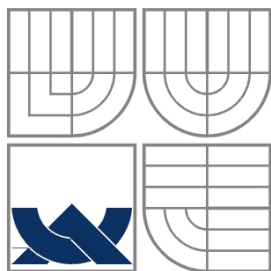

VYSOKÉ UČENÍ TECHNICKÉ V BRNĚ

BRNO UNIVERSITY OF TECHNOLOGY



FAKULTA STAVEBNÍ

ÚSTAV POZEMNÍHO STAVITELSTVÍ

FACULTY OF CIVIL ENGINEERING
INSTITUTE OF BUILDING STRUCTURES

A – ACCOMPANYING REPORT

DIPLOMOVÁ PRÁCE
MASTER'S THESIS

AUTOR PRÁCE
AUTHOR

BC. MARIAN HLAVICA

VEDOUCÍ PRÁCE
SUPERVISOR

doc. Ing. JIŘÍ SEDLÁK, CSc.

BRNO 2014

CONTENT

A.1. Identification.....	3
A.1.1 Information about structure	3
A.1.2 Information about investor.....	3
A.1.3 Information about author	3
A.2 List of used information sources.....	3
3. Information about current and future area build-up	4
4. Information about construction	4
4.1 General information.....	4
4.1 Access of disabled persons.....	4
4.2 Designed capacity of the structure	4
4.3 Basic properties of the structure	5
4.4 Designed duration of the construction of the structure.....	5
4.4 Rough costs estimation	5

A.1. Identification

A.1.1 Information about structure

Construction name: Low energy block of apartments

Address: Karla Schinzela street, Rýmařov, 795 01

Cadastral area: Rýmařov

Degree of project documentation: Realization documentation

Type of construction: New construction

A.1.2 Information about investor

Investor: Jan Novák

Investor's address: Slunečná 68, Rýmařov 795 01

A.1.3 Information about author

Author: Bc. Marian Hlavica

A.2 List of used information sources

- Information from cadastral bureau about the plot
- ČSN 73 4301 – Residential buildings
- ČSN 73 6056 – Parking areas for road vehicles
- ČSN 73 6058 – Small, multi-storey and mass garages
- ČSN 73 0540-2 – Thermal protection of buildings, requirements
- ČSN 73 0540-3 – Thermal protection of buildings, design value quantities
- ČSN 73 0818 – Fire protection of buildings – person/surface rate in buildings
- ČSN 73 0833 – Fire protection of buildings – buildings for dwelling and lodging
- ČSN 73 6110 – Design of urban roads
- ČSN EN 12 831 - Heating systems in buildings - Method for calculation of the design heat load
- ČSN 06 0210 - Calculation of heat losses in building with central heating
- ČSN 01 3452 - Technical drawings - Installations - Heating and refrigerating systems
- ČSN 73 4201 - Chimneys and connecting flue pipes - Design, construction and installation of heating appliances

- ČSN 01 3420 - Construction drawings - Presentation of general arrangement drawings
- Other ČSN
- Decree 62/2013 Coll.
- Information from negotiations with investor
- Information from manufacturer of used machinery

A.3 Information about current and future area build-up

The plot no. 342/27 and 342/28 cover 1487 m². The overall build-up area is 314 m². The plot has been recently transformed from arable land into building plot and there are no previous constructions there. There is public road with technical infrastructure in the close neighborhood of the plot. There is no historically significant area in the plot.

According to general urban plan the plot is supposed to carry structures for dwelling and accommodation which is the case of the designed structure so it is in overall consensus.

The construction and its accompanying works will take place on the plot mentioned above. No other plots will be interfered with during the construction '(except connection of the structure's technical infrastructure onto the existing public infrastructure).

A.4 Information about construction

A.4.1 General information

The design project solves a new construction of a block of apartments with parking garage. It consists of four two-room flats, four four-room flats and a studio. The structure is of a permanent character.

There are no special regulations on the construction.

A.4.1 Access of disabled persons

The access to the structure is barrier-free. All floors are connected with an elevator and the entry doors to the flats are minimally 800 mm wide. Should a disabled person consider using of one of the flats possible adjustments in door widths may be done with further consultation of a professional on fire safety and civil engineering.

A.4.2 Designed capacity of the structure

- build-up area: 314 m²
- build-up space: 3702,06 m³

- usable units: 9 usable units - four two-room flats (2 x 68,01 m², 2 x 65,36 m²), four four-room flats (4 x 99,73 m²), studio (34,31 m²)
- 25 users of the structure
- six garage parking spots

A.4.3 Basic properties of the structure

The energy-saving class of the structure: B

A.4.4 Designed duration of the construction of the structure

The basic parts of the structure (foundations, load-bearing structures, roof) will be done during one year. The final parts of the structure in another (inner constructions, final landscaping).

Duration of the construction: 24 months.

A.4.4 Rough costs estimation

5, 500, 000 CZK

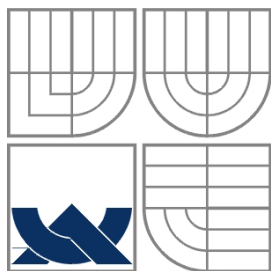

VYSOKÉ UČENÍ TECHNICKÉ V BRNĚ

BRNO UNIVERSITY OF TECHNOLOGY



FAKULTA STAVEBNÍ

ÚSTAV POZEMNÍHO STAVITELSTVÍ

FACULTY OF CIVIL ENGINEERING
INSTITUTE OF BUILDING STRUCTURES

B – SUMMARY TECHNICAL REPORT

DIPLOMOVÁ PRÁCE
MASTER'S THESIS

AUTOR PRÁCE
AUTHOR

BC. MARIAN HLAVICA

VEDOUCÍ PRÁCE
SUPERVISOR

doc. Ing. JIŘÍ SEDLÁK, CSc.

BRNO 2014

CONTENT

B.1 Description of the proposed building area	3
B.2 Overall description of the structure	3
B.2.1 The purpose and basic capacity of the structure	3
B.2.2 Overall urban and architectonic solution	3
B.2.3 Access of disabled persons	4
B.2.4 Health protection and safe usage of the structure	4
B.2.5 Fundamental parameters of the structure.....	5
Foundations	5
Vertical structures	5
Horizontal structures	6
Floor connection	7
Roof	8
Building services	8
External finishes.....	10
Doors and windows.....	10
Other.....	11
B.2.6 Fundamental parameters of building services' machinery	11
B.2.7 Fire safety solution.....	12
B.2.8 Energy treatment	12
B.2.9 Hygienic parameters of the structure.....	12
B.2.10 Protection of negative effect of external environment.....	12
B.3 Technical infrastructure connection	12
B.3 Traffic infrastructure connection	13
B.4 Solution of vegetation and connected terrain adjustments.....	13
B.5 Description of the influences of the construction on the environment	13
B.6 Inhabitants protection.....	13
B.7 Realization organization	13

B.1 Description of the proposed building area

The plot is situated in an urban area defined as dwelling area. The land is in a slight slope towards south and there is a public road with public technical infrastructure along the northern border of the plot.

There has been an expert evaluation on the geological state on the plot carried out. The foundation state is defined as simple. A specialized report on this problematics is attached in the part E of the project documentation.

There are no protection areas on the plot and the structure has no effect on the surrounding plots .

The connection on the public traffic infrastructure as well as technical infrastructure will be carried out on the neighborhood public road.

B.2 Overall description of the structure

B 2.1 The purpose and basic capacity of the structure

The project design solves a low-energy block of apartments.

- build-up area:
- build-up space:
- usable units: 9 usable units - four two-room flats (4x, four four-room flats (4x , studio (
- 25 users of the structure

B.2.2 Overall urban and architectonic solution

Urbanism – The area is intended for construction of dwelling structures so the proposed structured suffices the requirements. The structure is aligned with the nearby public road situated on the northern border of the building plot so it matches the overall logical situation of other nearby structures.

Architectonic solution – The structure is a low-energy four floor block of apartments partially depressed under surrounding terrain with flat warm roof and parking garage.

The shape of southern façade is roughly following elliptical curve to maximize solar gains in winter season while not increasing the total area of heat losses. The summer season over-heating protection is provided both with shading using balcony slabs and incorporated outside aluminum sun-blinds on the southern, eastern and western facades. Generally the habitable rooms are situated on the southern façade. Some are situated on the west and

east (bed rooms) ones. The non-habitable service rooms such as bathrooms and storages as well as the stairwell are situated on the northern façade. These layouts help to increase inner comfort in the building.

Each dwelling unit is equipped with bathroom and kitchen with recirculation hood to minimize heat losses, balcony access (except the studio) and enough storage space as visible in the architectonic part of the project documentation.

The structure is equipped with two garage doors to provide comfortable usage of the parking garage. The main entrance is through the main front door on the northern façade leading (through a corridor) to the double-sided elevator connecting all floors and back entrance allowing access to the backyard.

There are four sets of balconies situated on the southern façade each accessed from a single flat except for the studio.

The flats are accessible through the main stairwell with an elevator shaft connecting all floors while providing security safe escape route in case of fire. It also leads to the parking garage with bicycle and stroller storage, building clean-up room and service room.

Main areas of facades are finished with silicate plaster and white color coating. Building foot is finished with mosaic plaster – gray-silver pattern. All of the building's external tinsmith and locksmith product are either of neutral titan-zinc finish or provided with metallic gray coating. Window and French window frames are made of al/wood with aluminum finish on the outside. Main door will be composed of triple glazing and al/wood vertical part with handle.

B.2.3 Access of disabled persons

The object is accessible with all floors on the level of the elevator. The elevator connects all of them, the parking garage included. All the apartments' entry door, main door, elevator access and parking garage door are 800 mm or more wide. The entrance to the building is a stair-free platform sloped at 12% angle.

B.2.4 Health protection and safe usage of the structure

The building services' machinery must be operated by educated person only. The revision and cleaning of roof inlets must be processed by educated person only.

The Decree 324/1990 Coll. must be obeyed during construction works on the structure.

B.2.5 Fundamental parameters of the structure

Foundations

Foundations are solved as foundation strips and foundation pads. Both are at their tops covered with RC slab partially supported by the foundation and partially laying on compacted gravel layer.

The strips as well as pads will be formed with reinforced concrete (C 25/30, B 500 B). The further shape and arrangement of foundation is a content of particular drawing (D.1.1-05). All of the foundations must allow continuous attachment of reinforcement from RC walls forming the structural envelope and load-bearing part of the parking garage. Only preliminary design of RC elements of foundations was processed and further calculation carried out by a specialist on structural statics must be prepared.

The adequate voids in the foundations for building services (water supply ,gas supply, sewerage, electricity, communications) must be precisely measured in-situ and prepared according to the media suppliers and project documentation. The exact composition of foundations is visible in project documentation.

The RC slab (C 25/30, XC3, XD2, XF3, XA1, B 500 B) over foundation strips and pads forms a water-proofing layer also. Due to the high reinforcement of the slab carrying the static and dynamic load from the cars entering the parking garage the slab will also have properties of water-proof concrete and this must be also considered in the static solution. The concrete of the slab must have higher standard and muse be adjusted to the aggressive environment (salts from cars in winter season). This also concerns the external RC wall of the first underground floor. The water-proof concrete will be use to the height 360 mm above formation ground level.

A layer of compacted gravel fr. 16-32 mm will be placed underneath the RC slab.

Vertical structures

Arrangement and dimensions of all vertical constructions is defined in the drawing part of the project documentation.

Vertical load-bearing structures will be formed RC external walls (C 25/30, XC3, XD2, XF3, XA1, B 500 B), internal walls (C 25/30, B 500 B) and columns (300 x 300 mm, C 25/30, B 500 B) in the first underground floor. The external wall will serve as water-proofing using water-proof concrete and in it will also be provided with internal thermal insulation (MINERAL WOOL, min. $\lambda_k=0,039$ W/mK) from - 0,680 mm of structural height to the bottom face of RC

ceiling. This construction will help avoiding thermal bridging to the apartments above the area.

Vertical load-bearing structures in the above ground levels are formed with precise lime-sand blocks SILKA S20-2000 8DF th.240 mm. on construction adhesive (2 mm).

The external portion of these blocks will be on the outside provided with ETCIS system with EPS 70 F thermal insulation adhered to the blocks and anchored using anchors with PVC heads to avoid thermal bridging. The precise composition of the system is defined in the list of compositions (D.1.1-34).

The elevator shaft going through all floors will be made from reinforced concrete (C 20/25. B 500 B).

Internal partitions are formed with reinforce concrete (C 20/25. B 500 B) in first underground floor and with lime-sand partition blocks SILKA S20-2000 5DF th. 150 mm and NF th. 115 mm.

All of the internal walls – the load-bearing as well as partitions will be provided with internal lime-cement plaster, th. 12 mm and coating in white color where applicable or with ceramic tiling as more precisely defined in the drawing part of project documentation.

The openings in load-bearing structures as well as in the partitions will be overcome with half-prefabricated lintels SENDWIX and prefabricated lintels YTONG – more specification in the list of lintels (D.1.1-31) The SENDWIX lintels will be placed in mortar bed (M20, th. 12 mm) and the YTONG prefabricated lintels on construction adhesive (1 mm)

Each floor's vertical wall is finished with RC wreath (C 20/25. B 500 B) 240 x 380 mm which is a part of the continuous ceiling system.

Horizontal structures

The horizontal structures overlapping the area of floors are formed with reinforced concrete (C 25/30, B 500 B) one-way slabs continuously connected with RC wreaths on the load-bearing walls and girders.

The ceiling construction over the first underground floor is supported by RC (C 25/30, B 500 B) girders (300 x 530 mm) on RC (C 25/30, B 500 B) columns (300 x 300 mm) and RC wreaths on the vertical RC walls. The constructions consist of one-way slabs (th. 180 mm) and their supports as prescribed in detail in drawing part of PD. The openings in RC walls will

be overcome with hidden RC lintels as part of the RC wall. The girders, wreaths and slabs form one continuous system.

The girders will be provided with thermal insulation (MINERAL WOOL, min. $\lambda_k=0,039$ W/mK) to avoid thermal bridging to the spaces above. The slabs will be provided with thermal insulation according to proper composition. The opening in external masonry will be overcome with hidden lintel as part of the RC wreaths

The ceiling construction over first, second and third floor above ground is supported by RC wreaths on load-bearing masonry only and is formed with one-way RC slabs and their supports as prescribed in detail in drawing part of PD.

All of the ceiling constructions contain voids for installations. Their dimensions must be kept.

The ceilings without flooring or thermal insulation form 2700 mm of structural height.

The RC (C 25/30, B 500 B) balcony slabs are connected with the wreaths with ISO KORB K systems eliminating thermal bridging from the external environment.

Floor connection

The floor connection is realized with monolithic RC (C 25/30, B 500 B) staircase consisting of two stair flights 18 x 270 x 180 mm and two landings; and overlaps structural height 2880 mm as the height of individual floors.

The connection of the individual flights to the landings is provided with HALFEN HTT IMPACT SOUND INSULATION UNIT which will be incorporated into the formwork and reinforcement system during concreting. This precaution will avoid spreading of impact sound noise throughout the vertical and horizontal load-bearing systems.

There is an elevator shaft situated in the area of the staircase void. The shaft is formed with reinforced concrete and spreads from - 4,800 to + 9,265 of structural height. The shaft is provided with double-door elevator without engineering SCHINDLER 3100.

The railing of the staircase is connected to the elevator shaft and is described in detail in the list of locksmith products (D.1.1-33).

Roof

The roof is designed as warm roof with EPS 150 S thermal insulation in 220 mm thickness and mPVC water-proofing in one layer as prescribed in Czech standards and one layer of SBS Asphalt vapor-barrier. The precise composition of the roof is defined in the list of compositions (D.1.1-34).

The overall slope of the roof is 2%. The sloping is defined in drawing part of PD

Drainage of the roof is ensured with two roof inlets TOPWET TW 110 PVC S, DN 100 mm (210 m²; 6,3 l/s); provided with grid and leaf-catcher and two security over-flows DN 100 mm, provided with grid, placed 30 mm above the roof plane.

All of the installation penetrating the water-proofing layer of the roof must be provided with mPVC sleeve and tightened with metal strip.

The roof over elevator shaft composition is prescribed in detailed drawing.

All of the tinsmith products of the roof are plastic-applied to enable weld-on of the mPVC roof waterproofing and will be connected with the water-proofing to form a continuous layer.

Roof plane will be provided with safety anchoring points acc. ČSN EN 795 which will be prescribed by supplier of those.

The roof edge and its tinsmith products is also described in detailed drawing. It is connected to the RC wreaths with ISO KORB A system for thermal bridging elimination.

The access to the roof is provided with open-able skylight VELUX CXP as described in locksmith products (D.1.1-33) and detailed drawing."

The system solution FATRAFOL of the water-proofing layer with all additive parts (corners, etc.) will be applied.

The roof inlets must be checked and cleaned twice a year. The revision and cleaning of roof inlets must be processed by educated person only.

Building services

The building is provided with sewerage, water supply, gas supply and electricity network. Communications will be proposed as wireless.

The sewerage will be connected to the public unified sewerage network. There will be a shaft connecting rain sewerage and sludge sewerage with the public sewerage on the building

plot. It will be a prefabricated PE shaft with cast iron lid. Position is defined in situations. Proper voids in foundations must be manufactured for the network penetration.

The building's water supply will be connected to the public water supply. There will be a shaft connecting building's water supply and public water supply on the building plot. It will be a prefabricated PE shaft with cast iron lid. Proper voids in foundations must be manufactured for the network penetration.

The building's gas supply will be connected to the public low-pressure gas supply. Proper voids in foundations must be manufactured for the network penetration.

The building's electricity supply will be connected to the public electric network.

The building's communications networks will be connected to the public communications network.

All of the main risers of the media supply will be held in three main shafts leading to the east, south, and west part of the building. There will also be a several minor shaft for kitchen water supply and sewerage only. The shafts precise positions are stated in the drawings of ceilings. All the shafts will be enclosed with concrete infill in the level of ceiling constructions after mounting of installations.

The horizontal conducts of water supply, hot water supply and sewerage will be lead in installation plaster board partitions or in gaps drilled into the masonry.

The water supply, hot water supply, circulation and heating system conducts lead through the parking garage must be provided with thermal insulation (p.e. ISOFORM) th. 50 mm, min. $\lambda_k = 0,039 \text{ W/mk}$.

The roof drainage (2x DN 100) will be held in the eastern and western shaft.

The fumes of the condensing boilers defined in heating system concept will be ventilated through 2x doubled pipe 80/125 through the roof plane. The pipe end at a wind angle to the overlapping elevator shaft.

The toilets will be installed in the pre-lapping installation plaster-board (h = 1500 mm) wall with integrated water tank and ceramic tiling finish. Some of the basins will also be installed onto - lapping installation plaster-board (h = 900 mm) wall as defined in drawing part of PD.

External finishes,

The facades will be finished with silicate plaster with white coating. The foot of the building will be finished with mosaic plaster of grey-silver color.

The external finishes of window frames are aluminum. The garage door will be in gray color. Glazing of the windows and entry door is clear.

The tinsmith products are either in natural titan-zinc finish or metallic grey coating.

All of the aspects are defined in the lists of individual products.

Doors and windows

The windows of the first underground floor will be formed with al/wood frames and triple glazing windows (SLAVONA HOLZ ALU) with $U = 1,2$ W/mk declared by the manufacturer. The external finish of the frame: aluminum. The internal finish of the frame: aluminum.

The rest of the windows in the building will be formed with al/wood frames with triple glazing (SLAVONA HOLZ ALU) with $U = 0,72$ W/mk declared by the manufacturer. The external finish of the frame: aluminum. The internal finish of the frame: natural wood.

The entry doors will be formed with al/wood frames with triple glazing (SLAVONA HOLZ ALU) with $U = 0,72$ W/mk declared by the manufacturer. The external finish of the frame: aluminum. The internal finish of the frame: aluminum.

All of the windows except for the northern façade ones of the heated part of the building will be provided with external aluminum sunblinds with electric engine. The internal door will be wooden with aluminum handle and hinges. The internal sills will be formed with PVC sheet. The external sills will be made of titan-zinc sheets.

All of the doors and windows as well as tinsmith products relating to them are specified in the lists of individual products.

All apartments have windows on the southern façade and there are no buildings in front of the building plot so there will be enough insolation.

Other

The entry platform will be formed with RC slab (C 25/30, B 500 B) provided with outdoor adhesive with SCHÜTER DITRA 25 PE GRID and ceramic tiling. The platform will be sloped in 12% angle.

The backyard stairs and entry platform will be formed with RC (C 25/30, B 500 B) and provided with outdoor adhesive with SCHLÜTER DITRA 25 PE GRID and ceramic tiling.

The driveway, entry pavement, garbage zone and parking in front of the building will be formed with concrete interlocking tiles in sand bed (fr. 0-4 mm) and compacted gravel layer (fr. 16-32 mm). The driveway will be enclosed between two retaining walls of concrete lost formwork filled with concrete and reinforced (C 20/25, B 500 B) and finished with titan-zinc flashing.

The dripping pavement will be made of ceramic tiles 500 x 500 x 50 mm into sand bed (fr. 0-4 mm) and compacted gravel layer (fr. 16-32 mm) and secured with concrete pavement 50 x 100 mm into concrete bed (C 16/20).

The particular details not solved in this PD will be solved by the supplier of the construction.

B.2.6 Fundamental parameters of building services' machinery

The heating system concept is more precisely solved in PD part 1.4.1.

The heat production and production of hot water for the building is provided with condensing boilers. The boilers are intended to burn natural gas. The gas supply will be provided through connection to the public low pressure gas network.

The heat source for the calculated heating system demand of **43560,49 W** will be:

- 1 x Condensing boiler Buderus Logamax plus GB162-45, P=45kW

The hot water preparation source will be:

- 1 x Condensing boiler Buderus Logamax plus GB172-24, P=24kW24 in combination with water storage tank REGULUS RBC 1000, V=1000 l.

Both boilers will be of a type C – TURBO, the burning air supply will be provided with doubled pipe of diameter 80/125 as prescribed by manufacturer. In the summer season while only the hot water preparation will take place the GB162-45 boiler will be inactive.

B.2.7 Fire safety solution

A precise fire safety solution as a part of the PD (1.3.1) has been processed.

B.2.8 Energy treatment

A precise energy treatment solution as a part of the PD (E - PENB) has been processed.

The buildings envelope is categorized as B – very efficient

The yearly energy needs of the structure have been calculated as: **99 kWh/m²**.

There are no alternative energy-sources used in this construction.

B.2.9 Hygienic parameters of the structure

The structure is designed for 25 permanent residents.

The standard ventilation is natural. Ventilation of WCs, bathrooms and building clean-up room is over-pressure. The heating system is based on gas burning and as such has no significant negative influences on the environment. The water supply is provided with public water supply network. The sewerage pipes are finished with ventilation pipes.

The construction will have no significant influence on the surrounding environment.

B.2.10 Protection of negative effect of external environment

The water-proof RC slab over foundations and external water-proof RC walls of the first underground floor will serve as a protection against radon leakage as well.

The massive construction system and high standard windows will serve as a quality noise protection of the structure.

B.3 Technical infrastructure connection

The building's gas supply will be connected to the public low-pressure gas supply. Proper voids in foundations must be manufactured for the network penetration.

The building's electricity supply will be connected to the public electric network.

The solution of the connection to the network is only preliminary and will be defined in specialized project.

B.3 Traffic infrastructure connection

The building's driveways as well as the parking spots will be connected to the public road along the northern border of the plot. The road is in a dwelling area zone with lowered speed limit and not so high density of traffic.

B.4 Solution of vegetation and connected terrain adjustments

The terrain will be flattened before initiation of the construction.

There will be two rows of hedge aligning the entry pavement of the building and also one row at the backyard aligning the retaining wall of the backyard staircase. These will form natural railing.

B.5 Description of the influences of the construction on the environment

The structure have no significant influence on the environment

B.6 Inhabitants protection

The building meets the requirements according to the standards. The building services' machinery must be operated by educated person only. The revision and cleaning of roof inlets must be processed by educated person only.

The Decree 324/1990 Coll. must be obeyed during construction works on the structure.

B.7 Realization organization

The construction site will be connected with the existing public road along the northern border of the plot. The structure has no significant influence on the surrounding structures.

The building site will be fenced with mobile fences and only the staff of construction suppliers will be allowed inside the perimeter.

The excavated soil will be piled on the building plot and used for terrain adjustments in the end of the construction.

The Decree 324/1990 Coll. must be followed at all times.

The temporary connections to the electricity and water supply will be created. There will also be created a storage area, a unit for foremen and construction supervisor, unit for tools storage and mobile WC on the building site. The crane jobs will be provided with mobile crane.

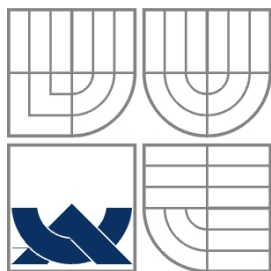

VYSOKÉ UČENÍ TECHNICKÉ V BRNĚ

BRNO UNIVERSITY OF TECHNOLOGY



FAKULTA STAVEBNÍ

ÚSTAV POZEMNÍHO STAVITELSTVÍ

FACULTY OF CIVIL ENGINEERING
INSTITUTE OF BUILDING STRUCTURES

C – SITUATIONS

DIPLOMOVÁ PRÁCE
MASTER'S THESIS

AUTOR PRÁCE
AUTHOR

BC. MARIAN HLAVICA

VEDOUCÍ PRÁCE
SUPERVISOR

doc. Ing. JIŘÍ SEDLÁK, CSc.

BRNO 2014

CONTENT OF FOLDER

- C.1 – Situation of further relations
- C.2 – Overall situation
- C.3 – Controlling situation

MASTER'S THESIS

STUDENT

Bc. Marian Hlavica

SUPERVISOR

doc. Ing. Jiří Sedlák, CSc.

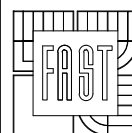

VUT V BRNĚ
FAKULTA STAVEBNÍ
VEVEŘÍ 331/95
602 00 Brno
TEL. 541 141 111

INSTITUTE OF CIVIL ENGINEERING

LOW ENERGY BLOCK OF APARTMENTS

DATE

17. 1. 2014

D.1 - DOCUMENTATION OF STRUCTURES

PART: D.1

CONTENT OF FOLDER

- D.1.1 – Architectonic – construction solution
- D.1.2 – Technical – construction solution – NOT SOLVED
- D.1.3 – Fire safety solution
- D.1.4.1 – Heating system concept

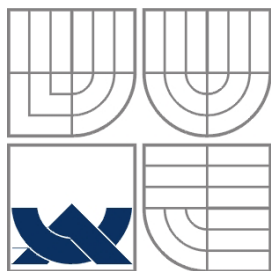

VYSOKÉ UČENÍ TECHNICKÉ V BRNĚ

BRNO UNIVERSITY OF TECHNOLOGY



FAKULTA STAVEBNÍ

ÚSTAV POZEMNÍHO STAVITELSTVÍ

FACULTY OF CIVIL ENGINEERING
INSTITUTE OF BUILDING STRUCTURES

D.1.1 – ARCHITECTONIC–CONSTRUCTION SOLUTION

DIPLOMOVÁ PRÁCE
MASTER'S THESIS

AUTOR PRÁCE
AUTHOR

BC. MARIAN HLAVICA

VEDOUCÍ PRÁCE
SUPERVISOR

doc. Ing. JIŘÍ SEDLÁK, CSc.

BRNO 2014

CONTENT OF FOLDER

D.1.1 Technical report

D.1.1 Drawings

- D.1.1-01 – Architectonic concept – Layout of 1st undg.floor
- D.1.1-02 – Architectonic concept – Layout of 1st floor
- D.1.1-03 – Architectonic concept – Layout of 2nd floor
- D.1.1-04 – Architectonic concept – Layout of 3rd floor
- D.1.1-05 – Layout of foundations
- D.1.1-06 – Layout of 1st undg. floor
- D.1.1-07 – Layout of 1st floor
- D.1.1-08 – Layout of 2nd floor
- D.1.1-09 – Layout of 3rd floor
- D.1.1-10 – Roof
- D.1.1-11 – Sectional elevation A-A'
- D.1.1-12 – Sectional elevation B-B'
- D.1.1-13 – Ceiling construction above 1st undg. floor
- D.1.1-14 – Ceiling construction above 1st floor
- D.1.1-15 – Ceiling construction above 2nd floor
- D.1.1-16 – Ceiling construction above 3rd floor
- D.1.1-17 – Southern elevation
- D.1.1-18 – Western elevation
- D.1.1-19 – Northern elevation
- D.1.1-20 – Eastern elevation

D.1.1 Documentation of particularities

- D.1.1-21 – Detail of roof edge
- D.1.1-22 – Detail of balcony slab
- D.1.1-23 – Detail of elevator shaft
- D.1.1-24 – Detail of roof inlet
- D.1.1-25 – Detail of window lintel
- D.1.1-26 – Detail of stair flight connection
- D.1.1-27 – Detail of roof access
- D.1.1-28 – Detail of window sill
- D.1.1-29 – List of windows
- D.1.1-30 – List of doors
- D.1.1-31 – List of lintels
- D.1.1-32 – List of tinsmith products
- D.1.1-33 – List of locksmith products
- D.1.1-34 – List of compositions
- D.1.1-35 – List of floor compositions

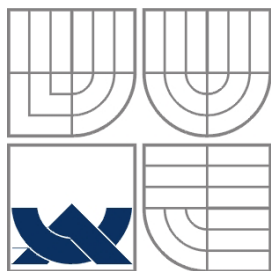

VYSOKÉ UČENÍ TECHNICKÉ V BRNĚ

BRNO UNIVERSITY OF TECHNOLOGY



FAKULTA STAVEBNÍ

ÚSTAV POZEMNÍHO STAVITELSTVÍ

FACULTY OF CIVIL ENGINEERING
INSTITUTE OF BUILDING STRUCTURES

D.1.1 – TECHNICAL REPORT

DIPLOMOVÁ PRÁCE
MASTER'S THESIS

AUTOR PRÁCE
AUTHOR

BC. MARIAN HLAVICA

VEDOUCÍ PRÁCE
SUPERVISOR

doc. Ing. JIŘÍ SEDLÁK, CSc.

BRNO 2014

CONTENT

1. The purpose and basic capacity of the structure	3
2. Overall urban and architectonic solution.....	3
Urbanism	3
Architectonic solution	3
3. Construction solution.....	4
Foundations	4
Vertical structures	5
Horizontal structures	6
Floor connection	6
Roof	7
External finishes.....	9
Doors and windows.....	9
Other.....	10

1. The purpose and basic capacity of the structure

The project design solves a low-energy block of apartments.

- build-up area: 314 m²
- build-up space: 3702,06 m³
- usable units: 9 usable units - four two-room flats (2 x 68,01 m², 2 x 65,36 m²), four four-room flats (4 x 99,73 m²), studio (34,31 m²)
- 25 users of the structure
- six garage parking spots

2. Overall urban and architectonic solution

Urbanism

The area is intended for construction of dwelling structures so the proposed structure suffices the requirements. The structure is aligned with the nearby public road situated on the northern border of the building plot so it matches the overall logical situation of other nearby structures.

Architectonic solution

The structure is a low-energy four floor block of apartments partially depressed under surrounding terrain with flat warm roof and parking garage.

The shape of southern façade is roughly following elliptical curve to maximize solar gains in winter season while not increasing the total area of heat losses. The summer season overheating protection is provided both with shading using balcony slabs and incorporated outside aluminum sun-blinds on the southern, eastern and western facades. Generally the habitable rooms are situated on the southern façade. Some are situated on the west and east (bed rooms) ones. The non-habitable service rooms such as bathrooms and storages as well as the stairwell are situated on the northern façade. These layouts help to increase inner comfort in the building.

Each dwelling unit is equipped with bathroom and kitchen with recirculation hood to minimize heat losses, balcony access (except the studio) and enough storage space as visible in the architectonic part of the project documentation.

The structure is equipped with two garage doors to provide comfortable usage of the parking garage. The main entrance is through the main front door on the northern façade leading (through a corridor) to the double-sided elevator connecting all floors and back entrance allowing access to the backyard.

There are four sets of balconies situated on the southern façade each accessed from a single flat except for the studio.

The flats are accessible through the main stairwell with an elevator shaft connecting all floors while providing security safe escape route in case of fire. It also leads to the parking garage with bicycle and stroller storage, building clean-up room and service room.

Main areas of facades are finished with silicate plaster and white color coating. Building foot is finished with mosaic plaster – gray-silver pattern. All of the building's external tinsmith and locksmith product are either of neutral titan-zinc finish or provided with metallic gray coating. Window and French window frames are made of al/wood with aluminum finish on the outside. Main door will be composed of triple glazing and al/wood vertical part with handle.

3. Construction solution

Foundations

Foundations are solved as foundation strips and foundation pads. Both are at their tops covered with RC slab partially supported by the foundation and partially laying on compacted gravel layer.

The strips as well as pads will be formed with reinforced concrete (C 25/30, B 500 B). The further shape and arrangement of foundation is a content of particular drawing (D.1.1-05). All of the foundations must allow continuous attachment of reinforcement from RC walls forming the structural envelope and load-bearing part of the parking garage. Only preliminary design of RC elements of foundations was processed and further calculation carried out by a specialist on structural statics must be prepared.

The adequate voids in the foundations for building services (water supply ,gas supply, sewerage, electricity, communications) must be precisely measured in-situ and prepared according to the media suppliers and project documentation. The exact composition of foundations is visible in project documentation.

The RC slab (C 25/30, XC3, XD2, XF3, XA1, B 500 B) over foundation strips and pads forms a water-proofing layer also. Due to the high reinforcement of the slab carrying the static and dynamic load from the cars entering the parking garage the slab will also have properties of water-proof concrete and this must be also considered in the static solution. The concrete of the slab must have higher standard and muse be adjusted to the aggressive environment (salts from cars in winter season). This also concerns the external RC wall of the first

underground floor. The water-proof concrete will be use to the height 360 mm above formation ground level.

A layer of compacted gravel fr. 16-32 mm will be placed underneath the RC slab.

Vertical structures

Arrangement and dimensions of all vertical constructions is defined in the drawing part of the project documentation.

Vertical load-bearing structures will be formed RC external walls (C 25/30, XC3, XD2, XF3, XA1, B 500 B), internal walls (C 25/30, B 500 B) and columns (300 x 300 mm, C 25/30, B 500 B) in the first underground floor. The external wall will serve as water-proofing using water-proof concrete and in it will also be provided with internal thermal insulation (MINERAL WOOL, min. $\lambda_k=0,039$ W/mK) from - 0,680 mm of structural height to the bottom face of RC ceiling. This construction will help avoiding thermal bridging to the apartments above the area.

Vertical load-bearing structures in the above ground levels are formed with precise lime-sand blocks SILKA S20-2000 8DF th.240 mm. on construction adhesive (2 mm).

The external portion of these blocks will be on the outside provided with ETCIS system with EPS 70 F thermal insulation adhered to the blocks and anchored using anchors with PVC heads to avoid thermal bridging. The precise composition of the system is defined in the list of compositions (D.1.1-34).

The elevator shaft going through all floors will be made from reinforced concrete (C 20/25. B 500 B).

Internal partitions are formed with reinforce concrete (C 20/25. B 500 B) in first underground floor and with lime-sand partition blocks SILKA S20-2000 5DF th. 150 mm and NF th. 115 mm.

All of the internal walls – the load-bearing as well as partitions will be provided with internal lime-cement plaster, th. 12 mm and coating in white color where applicable or with ceramic tiling as more precisely defined in the drawing part of project documentation.

The openings in load-bearing structures as well as in the partitions will be overcame with half-prefabricated lintels SENDWIX and prefabricated lintels YTONG – more specification in the list of lintels (D.1.1-31) The SENDWIX lintels will be placed in mortar bed (M20, th. 12 mm) and the YTONG prefabricated lintels on construction adhesive (1 mm)

Each floor's vertical wall is finished with RC wreath (C 20/25. B 500 B) 240 x 380 mm which is a part of the continuous ceiling system.

Horizontal structures

The horizontal structures overlapping the area of floors are formed with reinforced concrete (C 25/30, B 500 B) one-way slabs continuously connected with RC wreaths on the load-bearing walls and girders.

The ceiling construction over the first underground floor is supported by RC (C 25/30, B 500 B) girders (300 x 530 mm) on RC (C 25/30, B 500 B) columns (300 x 300 mm) and RC wreaths on the vertical RC walls. The constructions consist of one-way slabs (th. 180 mm) and their supports as prescribed in detail in drawing part of PD. The openings in RC walls will be overcome with hidden RC lintels as part of the RC wall. The girders, wreaths and slabs form one continuous system.

The girders will be provided with thermal insulation (MINERAL WOOL, min. $\lambda_k=0,039$ W/mK) to avoid thermal bridging to the spaces above. The slabs will be provided with thermal insulation according to proper composition. The opening in external masonry will be overcome with hidden lintel as part of the RC wreaths

The ceiling construction over first, second and third floor above ground is supported by RC wreaths on load-bearing masonry only and is formed with one-way RC slabs and their supports as prescribed in detail in drawing part of PD.

All of the ceiling constructions contain voids for installations. Their dimensions must be kept.

The ceilings without flooring or thermal insulation form 2700 mm of structural height.

The RC (C 25/30, B 500 B) balcony slabs are connected with the wreaths with ISO KORB K systems eliminating thermal bridging from the external environment.

Floor connection

The floor connection is realized with monolithic RC (C 25/30, B 500 B) staircase consisting of two stair flights 18 x 270 x 180 mm and two landings; and overlaps structural height 2880 mm as the height of individual floors.

The connection of the individual flights to the landings is provided with HALFEN HTT IMPACT SOUND INSULATION UNIT which will be incorporated into the formwork and reinforcement system during concreting. This precaution will avoid spreading of impact sound noise throughout the vertical and horizontal load-bearing systems.

There is an elevator shaft situated in the area of the staircase void. The shaft is formed with reinforced concrete and spreads from – 4,800 to + 9,265 of structural height. The shaft is provided with double-door elevator without engineering SCHINDLER 3100.

The railing of the staircase is connected to the elevator shaft and is described in detail in the list of locksmith products (D.1.1-33).

Roof

The roof is designed as warm roof with EPS 150 S thermal insulation in 220 mm thickness and mPVC water-proofing in one layer as prescribed in Czech standards and one layer of SBS Asphalt vapor-barrier. The precise composition of the roof is defined in the list of compositions (D.1.1-34).

The overall slope of the roof is 2%. The sloping is defined in drawing part of PD

Drainage of the roof is ensured with two roof inlets TOPWET TW 110 PVC S, DN 100 mm (210 m²; 6,3 l/s); provided with grid and leaf-catcher and two security over-flows DN 100 mm, provided with grid, placed 30 mm above the roof plane.

All of the installation penetrating the water-proofing layer of the roof must be provided with mPVC sleeve and tightened with metal strip.

The roof over elevator shaft composition is prescribed in detailed drawing.

All of the tinsmith products of the roof are plastic-applied to enable weld-on of the mPVC roof waterproofing and will be connected with the water-proofing to form a continuous layer.

Roof plane will be provided with safety anchoring points acc. ČSN EN 795 which will be prescribed by supplier of those.

The roof edge and its tinsmith products is also described in detailed drawing. It is connected to the RC wreaths with ISO KORB A system for thermal bridging elimination.

The access to the roof is provided with open-able skylight VELUX CXP as described in locksmith products (D.1.1-33) and detailed drawing."

The system solution FATRAFOL of the water-proofing layer with all additive parts (corners, etc.) will be applied.

The roof inlets must be checked and cleaned twice a year. The revision and cleaning of roof inlets must be processed by educated person only. Building services

The building is provided with sewerage, water supply, gas supply and electricity network. Communications will be proposed as wireless.

The sewerage will be connected to the public unified sewerage network. There will be a shaft connecting rain sewerage and sludge sewerage with the public sewerage on the building plot. It will be a prefabricated PE shaft with cast iron lid. Position is defined in situations. Proper voids in foundations must be manufactured for the network penetration.

The building's water supply will be connected to the public water supply. There will be a shaft connecting building's water supply and public water supply on the building plot. It will be a prefabricated PE shaft with cast iron lid. Proper voids in foundations must be manufactured for the network penetration.

The building's gas supply will be connected to the public low-pressure gas supply. Proper voids in foundations must be manufactured for the network penetration.

The building's electricity supply will be connected to the public electric network.

The building's communications networks will be connected to the public communications network.

All of the main risers of the media supply will be held in three main shafts leading to the east, south, and west part of the building. There will also be a several minor shaft for kitchen water supply and sewerage only. The shafts precise positions are stated in the drawings of ceilings. All the shafts will be enclosed with concrete infill in the level of ceiling constructions after mounting of installations.

The horizontal conducts of water supply, hot water supply and sewerage will be lead in installation plaster board partitions or in gaps drilled into the masonry.

The water supply, hot water supply, circulation and heating system conducts lead through the parking garage must be provided with thermal insulation (p.e. ISOFORM) th. 50 mm, min. $\lambda_k = 0,039 \text{ W/mk}$.

The roof drainage (2x DN 100) will be held in the eastern and western shaft.

The fumes of the condensing boilers defined in heating system concept will be ventilated through 2x doubled pipe 80/125 through the roof plane. The pipe end at a wind angle to the overlapping elevator shaft.

The toilets will be installed in the pre-lapping installation plaster-board (h = 1500 mm) wall with integrated water tank and ceramic tiling finish. Some of the basins will also be installed onto - lapping installation plaster-board (h = 900 mm) wall as defined in drawing part of PD.

External finishes

The facades will be finished with silicate plaster with white coating. The foot of the building will be finished with mosaic plaster of grey-silver color.

The external finishes of window frames are aluminum. The garage door will be in gray color. Glazing of the windows and entry door is clear.

The tinsmith products are either in natural titan-zinc finish or metallic grey coating.

All of the aspects are defined in the lists of individual products.

Doors and windows

The windows of the first underground floor will be formed with al/wood frames and triple glazing windows (SLAVONA HOLZ ALU) with $U = 1,2$ W/mk declared by the manufacturer. The external finish of the frame: aluminum. The internal finish of the frame: aluminum.

The rest of the windows in the building will be formed with al/wood frames with triple glazing (SLAVONA HOLZ ALU) with $U = 0,72$ W/mk declared by the manufacturer. The external finish of the frame: aluminum. The internal finish of the frame: natural wood.

The entry doors will be formed with al/wood frames with triple glazing (SLAVONA HOLZ ALU) with $U = 0,72$ W/mk declared by the manufacturer. The external finish of the frame: aluminum. The internal finish of the frame: aluminum.

All of the windows except for the northern façade ones of the heated part of the building will be provided with external aluminum sunblinds with electric engine. The internal door will be wooden with aluminum handle and hinges. The internal sills will be formed with PVC sheet. The external sills will be made of titan-zinc sheets.

All of the doors and windows as well as tinsmith products relating to them are specified in the lists of individual products.

All apartments have windows on the southern façade and there are no buildings in front of the building plot so there will be enough insolation.

Other

The entry platform will be formed with RC slab (C 25/30, B 500 B) provided with outdoor adhesive with SCHÜTER DITRA 25 PE GRID and ceramic tiling. The platform will be sloped in 12% angle.

The backyard stairs and entry platform will be formed with RC (C 25/30, B 500 B) and provided with outdoor adhesive with SCHLÜTER DITRA 25 PE GRID and ceramic tiling.

The driveway, entry pavement, garbage zone and parking in front of the building will be formed with concrete interlocking tiles in sand bed (fr. 0-4 mm) and compacted gravel layer (fr. 16-32 mm). The driveway will be enclosed between two retaining walls of concrete lost formwork filled with concrete and reinforced (C 20/25, B 500 B) and finished with titan-zinc flashing.

The dripping pavement will be made of ceramic tiles 500 x 500 x 50 mm into sand bed (fr. 0-4 mm) and compacted gravel layer (fr. 16-32 mm) and secured with concrete pavement 50 x 100 mm into concrete bed (C 16/20).

The particular details not solved in this PD will be solved by the supplier of the construction.

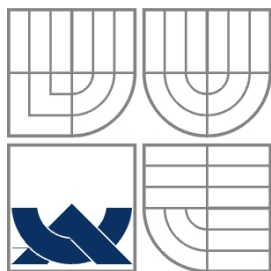

VYSOKÉ UČENÍ TECHNICKÉ V BRNĚ

BRNO UNIVERSITY OF TECHNOLOGY



FAKULTA STAVEBNÍ

ÚSTAV POZEMNÍHO STAVITELSTVÍ

FACULTY OF CIVIL ENGINEERING
INSTITUTE OF BUILDING STRUCTURES

D.1.1-34 – LIST OF COMPOSITIONS

DIPLOMOVÁ PRÁCE
MASTER'S THESIS

AUTOR PRÁCE
AUTHOR

BC. MARIAN HLAVICA

VEDOUCÍ PRÁCE
SUPERVISOR

doc. Ing. JIŘÍ SEDLÁK, CSc.

BRNO 2014

Composition name	Mark	Layers				
		Function	Product	Properties	Notes	Thickness (mm)
ETICS	C1	COATING	WEBER.DECO MAL	Dispersion, whiteness 90%		
		INTERNAL PLASTER	WEBER.DUR ŠTUK IN	Lime, MVJ 310		2
			WEBER.DUR KLASIK KRU	Lime-cement, MVC650		10
		PRIMER	WEBER.PODKLAD A			
		LOAD-BEARING LAYER	LIME-SAND BLOCK SILKA, 8DF	on construction adhesive 2 mm		240
		PRIMER	WEBER.PODKLAD A			
		ADHESIVE	WEBER.TMEL 700			4
		THERMAL INSULATION	EPS 70 F	$\lambda_D=0,040W/mK$		
		ADHESIVE	WEBER.TMEL 700	provided with glass-fibre reinforcement		4
	PLASTER	WEBER.PAS SILIKÁT	silicate plaster, grain max. 2 mm		2	
ETICS WITH XPS	C2	COATING	WEBER.DECO MAL	Dispersion, whiteness 90%		
		INTERNAL PLASTER	WEBER.DUR ŠTUK IN	Lime, MVJ 310		2
			WEBER.DUR KLASIK KRU	Lime-cement, MVC650		10
		PRIMER	WEBER.PODKLAD A			
		LOAD-BEARING LAYER	LIME-SAND BLOCK SILKA, 8DF	on construction adhesive 2 mm		240
		PRIMER	WEBER.PODKLAD A			
		ADHESIVE	WEBER.TMEL 700			4
		THERMAL INSULATION	XPS	$\lambda_D=0,034W/mK$		90
		ADHESIVE	WEBER.TMEL 700	provided with glass-fibre reinforcement		4
	PLASTER	WEBER.PAS MARMOLIT	mosaic plaster, grain max. 2 mm		2	

ROOF	C3	COATING	WEBER.DECO MAL	Dispersion, whiteness 90%		
			WEBER.DUR ŠTUK IN	Lime, MVJ 310		2
		INTERNAL PLASTER	WEBER.DUR KLASIK KRU	Lime-cement, MVC650		10
		PRIMER	WEBER.PODKLAD A			
		LOAD-BEARING LAYER	RC slab	C 25/30, B 500 B		180
		VAPOR BARRIER	ROOFTEK AL SPECIAL MINERAL SBS BITUMEN FELT	$\mu=250\ 000 (+- 20\ 000)$	melted onto the surface in spots	8
		SEPARATION	NON-VOWEN TEXTILE	300 g/m ²		4
		THERMAL INSULATION, SLOPING LAYER	EPS 150 S in 2% slope	$\lambda_D=0,035W/mK$		20 - 230
		THERMAL INSULATION	EPS 150 S	$\lambda_D=0,035W/mK$		200
		SEPARATION	NON-VOWEN TEXTILE	300 g/m ²		4
		WATER-PROOFING	FATRAFOL 807 mPVC foil	$\mu=8200 (+- 2000)$	anchored to the lb. layer using anchors with plastic heads	1

ROOF OVER BALCONY	C4	PLASTER	WEBER.PAS SILIKÁT	silicate plaster, grain max. 2 mm		2
		ADHESIVE	WEBER.TMEL 700	provided with glass-fibre reinforcement		4
		PRIMER	WEBER.PODKLAD A			0
		LOAD-BEARING LAYER	RC balcony slab	C 25/30, B 500 B	connected with ISO KORB K system	160
		VAPOR BARRIER	ROOFTEK AL SPECIAL MINERAL SBS BITUMEN FELT	$\mu=250\ 000 (+- 20\ 000)$	melted onto the surface in spots	8
		SEPARATION	NON-VOWEN TEXTILE	300 g/m ²		4
		SLOPING LAYER	EPS 150 S in 2% slope			20 - 40
		SEPARATION	NON-VOWEN TEXTILE	300 g/m ²		4
		WATER-PROOFING	FATRAFOL 807 mPVC foil	$\mu=8200 (+- 2000)$	anchored to the lb.	1

GARAGE WALL	C5	COATING	WEBER.DECO MAL	Dispersion, whiteness 90%		
			WEBER.DUR ŠTUK IN	Lime, MVJ 310		2
		INTERNAL PLASTER	WEBER.DUR KLASIK KRU	Lime-cement, MVC650		10
		PRIMER	WEBER.PODKLAD A			
		LOAD-BEARING LAYER	RC wall	C 25/30, B 500 B		300, 150
		PRIMER	WEBER.PODKLAD A			
		ADHESIVE	WEBER.TMEL 700			4
		THERMAL INSULATION	ISOVER NF 333 V	$\lambda_D=0,041W/mK$		90
		ADHESIVE	WEBER.TMEL 700	provided with glass-fibre reinforcement		4
		PLASTER	WEBER.PAS SILIKÁT	silicate plaster, grain max. 2 mm		2

INTERNAL WALLS / PARTITIONS	C6	COATING	WEBER.DECO MAL	Dispersion, whiteness 90%		
			WEBER.DUR ŠTUK IN	Lime, MVJ 310		2
		INTERNAL PLASTER	WEBER.DUR KLASIK KRU	Lime-cement, MVC650		10
		PRIMER	WEBER.PODKLAD A			
		LOAD-BEARING LAYER, PARTITION	LIME-SAND BLOCK SILKA, 8DF; RC WALL, LIME-SAND PARTITION SILKA	C 25/30, B 500 B		150, 250
		PRIMER	WEBER.PODKLAD A			
		INTERNAL PLASTER	WEBER.DUR KLASIK KRU	Lime-cement, MVC650		10
			WEBER.DUR ŠTUK IN	Lime, MVJ 310		2
		COATING	WEBER.DECO MAL	Dispersion, whiteness 90%		

ACOUSTIC PARTITION	C7	BORDER LAYER	DOUBLED PLASTER BOARD		Rw = 48 dB, R'w = 52 dB	25
		ACOUSTIC INSULATION	MINERAL WOOL, KANUF Insulation TP 115			60
		STABILIZATION LAYER	METAL STABILIZATION PROFILE CW 75 KNAUF			75
		STABILIZATION LAYER	METAL STABILIZATION PROFILE CW 75 KNAUF			75
		ACOUSTIC INSULATION	MINERAL WOOL, KANUF Insulation TP 115			60
		BORDER LAYER	DOUBLED PLASTER BOARD			25

RETAINING WALL	C8	LOAD-BEARING LAYER	CONCRETE LOST FORMWORK	filled with concrete C 20/25; provided with steel reinforcement B 500 B	titan-zinc flashing on top	150, 250
-----------------------	-----------	--------------------	------------------------	---	----------------------------	----------

BUILDING FOOT	C9	COATING	WEBER.DECO MAL	Dispersion, whiteness 90%		
			WEBER.DUR ŠTUK IN	Lime, MVJ 310		2
		INTERNAL PLASTER	WEBER.DUR KLASIK KRU	Lime-cement, MVC650		10
		PRIMER	WEBER.PODKLAD A			
		LOAD-BEARING LAYER, WATER-PROOFING	RC Wall	C 25/30, XC3, XD2, XF3, XA1, B 500 B, water-proof concrete		300
		PRIMER	WEBER.PODKLAD A			
		ADHESIVE	WEBER.TMEL 700	provided with glass-fibre reinforcement		4
		PLASTER	WEBER.PAS MARMOLIT	mosaic plaster, grain max. 2 mm		2

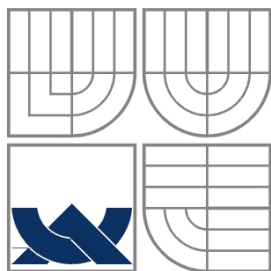

VYSOKÉ UČENÍ TECHNICKÉ V BRNĚ

BRNO UNIVERSITY OF TECHNOLOGY



FAKULTA STAVEBNÍ

ÚSTAV POZEMNÍHO STAVITELSTVÍ

FACULTY OF CIVIL ENGINEERING
INSTITUTE OF BUILDING STRUCTURES

D.1.1-35 – LIST OF FLOOR COMPOSITIONS

DIPLOMOVÁ PRÁCE
MASTER'S THESIS

AUTOR PRÁCE
AUTHOR

BC. MARIAN HLAVICA

VEDOUCÍ PRÁCE
SUPERVISOR

doc. Ing. JIŘÍ SEDLÁK, CSc.

BRNO 2014

Floor composition name	Mark	Layers				
		Function	Product	Properties	Notes	Thickness (mm)
FLOOR IN 2nd AND 3rd FLOOR - WOODEN FINISH	F1	FLOOR FINISH	WOODEN FINISH	Interlocking		15
		LEVELLING LAYER	CEMEX AnhyLEVEL 30	Compress. strength > 20 Mpa, Volume-mass = 2100-2200 kg/m ³ , Grain max 4 mm		35
		SEPARATION	PE FOIL			
		ACOUSTIC INSULATION	ISOVER TDPT	Compressibility <= 2		50
		LOAD-BEARING LAYER	RC slab	C 25/30, B 500 B		180
		PRIMER	WEBER.PODKLAD A			
		INTERNAL PLASTER	WEBER.DUR KLASIK KRU	Lime-cement, MVC650		10
		COATING	WEBER.DUR ŠTUK IN	Lime, MVJ 310		2
FLOOR IN 2nd AND 3rd FLOOR - CERAMIC TILES	F2	FLOOR FINISH	CERAMIC TILES			10
		F.F. ADHESION	WEBER FOR KLASIK			5
		SECURITY WATER-PROOFING	WEBER AKRYZOL		BATHROOMS ONLY	
		PRIMER	WEBER.PODKLAD A			
		LEVELLING LAYER	CEMEX AnhyLEVEL 30	Compress. strength > 20 Mpa, Volume-mass = 2100-2200 kg/m ³ , Grain max 4 mm		35
		SEPARATION	PE FOIL			
		ACOUSTIC INSULATION	ISOVER TDPT	Compressibility <= 2		50
		LOAD-BEARING LAYER	RC slab	C 25/30, B 500 B		180
		PRIMER	WEBER.PODKLAD A			
		INTERNAL PLASTER	WEBER.DUR KLASIK KRU	Lime-cement, MVC650		10
		COATING	WEBER.DUR ŠTUK IN	Lime, MVJ 310		2
		COATING	WEBER.DUR ŠTUK IN	Dispersion, whiteness 90%		

FLOOR IN 1st FLOOR - WOODEN FINISH	F3	FLOOR FINISH	WOODEN FINISH	Interlocking		15
		LEVELLING LAYER	CEMEX AnhyLEVEL 30	Compress. strength > 20 Mpa, Volume-mass = 2100-2200 kg/m ³ , Grain max 4 mm		35
		SEPARATION	PE FOIL			
		ACOUSTIC INSULATION	ISOVER TDPT	Compressibility <= 2		50
		LOAD-BEARING LAYER	RC slab	C 25/30, B 500 B		180
		PRIMER	WEBER.PODKLAD A			
		ADHESIVE	WEBER.TMEL 700			4
		THERMAL INSULATION	ISOVER NF 333 V	$\lambda_D=0,041W/mK$		90
		ADHESIVE	WEBER.TMEL 700	provided with glass-fibre reinforcement		4
		PLASTER	WEBER.PAS SILIKÁT	silicate plaster, grain max. 2 mm		2

FLOOR IN 1st FLOOR - CERAMIC TILES	F4	FLOOR FINISH	CERAMIC TILES			10
		F.F. ADHESION	WEBER FOR KLASIK			5
		SECURITY WATER-PROOFING PRIMER	WEBER AKRYZOL		BATHROOMS ONLY	
		PRIMER	WEBER.PODKLAD A			
		LEVELLING LAYER	CEMEX AnhyLEVEL 30	Compress. strength > 20 Mpa, Volume-mass = 2100-2200 kg/m ³ , Grain max 4 mm		35
		SEPARATION	PE FOIL			
		ACOUSTIC INSULATION	ISOVER TDPT	Compressibility <= 2		50
		LOAD-BEARING LAYER	RC slab	C 25/30, B 500 B		180
		PRIMER	WEBER.PODKLAD A			
		ADHESIVE	WEBER.TMEL 700			4
		THERMAL INSULATION	ISOVER NF 333 V	$\lambda_D=0,041W/mK$		90
		ADHESIVE	WEBER.TMEL 700	provided with glass-fibre reinforcement		4
PLASTER	WEBER.PAS SILIKÁT	silicate plaster, grain max. 2 mm		2		

FLOOR IN GARAGE	F5	FLOOR FINISH	EPOXY POURED FLOOR ELPOX	color RAL 1019		1
		PRIMER	WEBER.PODKLAD A			
		LEVELLING LAYER	REINFORCED CEMENT SCREED	C 16/20, reinforcing grids 100 x 100 x 6, B 500 B		124
		ACOUSTIC DILATATION	RUBBER RECYCLATE			25
		LOAD-BEARING LAYER, WATER-PROOFING	RC slab	C 25/30, XC3, XD2, XF3, XA1, B 500 B, water-proof concrete		200
		FALTTENING LAYER	COMPACTED GRAVEL	fr. 16-32 mm		125
			ORIGINAL SOIL			
FLOOR IN SERVICE ROOM ETC.	F6	FLOOR FINISH	CERAMIC TILES			10
		F.F. ADHESION	WEBER FOR KLASIK			5
		SECURITY WATER-PROOFING	WEBER AKRYZOL		BATHROOMS ONLY	
		PRIMER	WEBER.PODKLAD A			
		LEVELLING LAYER	CEMEX AnhyLEVEL 30	Compress. strength > 20 Mpa, Volumemass = 2100-2200 kg/m ³ , Grain max 4 mm		35
		SEPARATION	PE FOIL			
		THERMAL INSULATION	EPS 200 S	$\lambda_D=0,033$ W/mK		100
		LOAD-BEARING LAYER, WATER-PROOFING	RC slab	C 25/30, XC3, XD2, XF3, XA1, B 500 B, water-proof concrete		200
		FALTTENING LAYER	COMPACTED GRAVEL	fr. 16-32 mm		125
	ORIGINAL SOIL					
DRIVEWAY	F7	FINISH	CONCRETE TILES	Interlocking		60
		LEVELLING LAYER	SAND BED	fr. 0-4 mm		100
		LEVELLING LAYER	COMPACTED GRAVEL	fr. 16-32 mm		200
			ORIGINAL SOIL			

DRIPPING PAVEMENT	F8	FINISH	CONCRETE TILES 500x500x50 mm	secured with pavement 50x100 mm in concrete (C 16/20) bed		50
		LEVELLING LAYER	SAND BED	fr. 0-4 mm		100
		LEVELLING LAYER	COMPACTED GRAVEL	ft. 16-32 mm		150
			ORIGINAL SOIL			

ENTRANCE PLATFORMS	F9	FLOOR FINISH	CERAMIC TILES			10
		ADHESIVE + WATER-PROOFING	WEBER.FOR DUOFLEX with SCHLÜTER DITRA 25 PE GRID			5
		PRIMER	WEBER.PODKLAD A			
		LOAD-BEARING LAYER	RC slab	C 20/25, B 500 B		100 - 250
		LEVELLING LAYER	COMPACTED GRAVEL	fr. 16-32 mm		150
			ORIGINAL SOIL			

BALCONY SLAB	F10	FLOOR FINISH	CERAMIC TILES			10
		ADHESIVE + WATER-PROOFING	WEBER.FOR DUOFLEX with SCHLÜTER DITRA 25 PE GRID			5
		PRIMER	WEBER.PODKLAD A			
		LEVELLING LAYER	CEMENT SCREED	C 16/20		10.30
		LOAD-BEARING LAYER	RC balcony slab	C 25/30, B 500 B	connected with ISO KORB K system	160
		PRIMER	WEBER.PODKLAD A	fr. 16-32 mm		
		ADHESIVE	WEBER.TMEL 700	provided with glass-fibre reinforcement		4
		PLASTER	WEBER.PAS SILIKÁT	silicate plaster, grain max. 2 mm		2

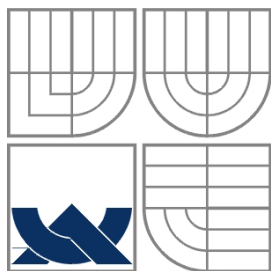

VYSOKÉ UČENÍ TECHNICKÉ V BRNĚ

BRNO UNIVERSITY OF TECHNOLOGY



FAKULTA STAVEBNÍ

ÚSTAV POZEMNÍHO STAVITELSTVÍ

FACULTY OF CIVIL ENGINEERING
INSTITUTE OF BUILDING STRUCTURES

D.1.3 – FIRE SAFETY SOLUTION

DIPLOMOVÁ PRÁCE
MASTER'S THESIS

AUTOR PRÁCE
AUTHOR

BC. MARIAN HLAVICA

VEDOUCÍ PRÁCE
SUPERVISOR

doc. Ing. JIŘÍ SEDLÁK, CSc.

BRNO 2014

CONTENT OF FOLDER

D.1.3 Technical report

D.1.3 Drawings

- D.1.3-01 – Fire safety situation
- D.1.3-02 - Layout of 1st undg. floor
- D.1.3-03 – Layout of 1st floor
- D.1.3-04 – Layout of 2nd floor
- D.1.3-05 – Layout of 3rd floor

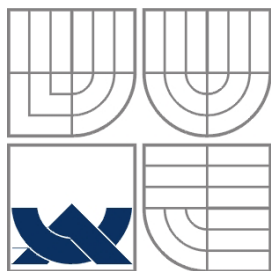

VYSOKÉ UČENÍ TECHNICKÉ V BRNĚ

BRNO UNIVERSITY OF TECHNOLOGY



FAKULTA STAVEBNÍ

ÚSTAV POZEMNÍHO STAVITELSTVÍ

FACULTY OF CIVIL ENGINEERING
INSTITUTE OF BUILDING STRUCTURES

D.1.3 - TECHNICAL REPORT

DIPLOMOVÁ PRÁCE
MASTER'S THESIS

AUTOR PRÁCE
AUTHOR

BC. MARIAN HLAVICA

VEDOUCÍ PRÁCE
SUPERVISOR

doc. Ing. JIŘÍ SEDLÁK, CSc.

BRNO 2014

CONTENT

1. Identification	3
2. List od used information sources	3
3. General information	3
3.1 Brief construction description	3
3.2 Disposition description	4
3.3 Structural solution	4
4. Fire safety evaluation	4
4.1 Brief construction description	4
4.2 Object division into fire sectors.....	5
4.3 Definition of fire hazard, degree of fire safety and evaluation of the fire sectors size	5
4.4 Fire resistance of the constructions requirements	7
4.5 Escape routes	9
4.6 Fire hazardous area.....	9
4.6 Fire water supply.....	10
4.7 Access	10
4.8 Mobile extinguisher	10
4.9 Technical equipment of the structure	11
4.10 Special requirements on building constructions.....	11
4.11 Requirements on automatic fire sensors	11
5. Safety marks and tables	11
5. Conclusion	11

1. Identification

Construction name: Low energy block of apartments

Address: Karla Schinzela street, Rýmařov, 795 01

Cadastral area: Rýmařov

Degree of project documentation: Realization documentation

Type of construction: New construction

Investor: Jan Novák

Investor's address: Slunečná 68, Rýmařov 795 01

Author: Bc. Marian Hlavica

2. List of used information sources

As the information sources for the fire safety documentation processing were used these sources:

- Project documentation – architectonic-construction part
- ČSN 73 0802 – PBS Non-production objects (05/2009)
- ČSN 73 0873 – PBS Fire safety water supply (06/2003)
- ČSN 73 0833 – PBS Buildings for dwelling and accommodation (04/8009)
- Decree no. 246/200 Coll. About fire hazard prevention
- Law 133/1998 Coll. About fire safety

3. General information

3.1 Brief construction description

The project solves construction of a low energy block of apartments which is a single building with three floors above ground and one partially underground (acc. to ČSN 73 0802 regarded as above ground) floor with open parking garage. The underground floor's load-bearing construction is formed with reinforced concrete walls. The rest of the vertical load-bearing constructions is formed with lime-sand masonry except for the elevator shaft construction which is of reinforced concrete.

From the fire safety point of view the structure is composed of non-flammable materials.

The entrance to the building is situated in the northern façade on a half-landing situated between und. floor and first floor and serves as a building's escape way. The structure is situated in a slightly sloped terrain. The object's height is designed to be 11,007 m.

3.2 Disposition description

The solved construction consists of parking garage, trolley storage, bicycle storage, utility room, service room and building clean-up room in the und. floor. There are three flats per each floor above ground, corridor, stairwell and elevator shaft. There are four two-room flats, four room-flats and one studio.

3.3 Structural solution

Vertical load-bearing

The solved construction's vertical load-bearing constructions consist of RC walls and lime-sand blocks masonry SENDWIX. The external walls are provided with ETICS.

Vertical non load-bearing

The non-bearing constructions are formed with lime-sand block partitions SILKA.

Horizontal load-bearing

The horizontal constructions are formed with RC monolithic continuous slabs.

Staircase

The connection between floors is provided with RC monolithic staircase.

4. Fire safety evaluation

4.1 Brief construction description

The structure is formed with non-flammable building materials acc. To the decree 23/2008 Coll. and acc. ČSN 73 0802 and other relevant standards.

- Construction system – non-flammable (except the ETICS system, the fire reaction – max. E)
- Fire safety height of the structure $h = 5,76$ m
- Build-up area: 314,04 m²
- Object height: 11,007 m

4.2 Object division into fire sectors

Acc. ČSN 73 0802, ČSN 73 0833:

There are 11 fire sectors in the building:

N 1.01, N 3.03 (each 68,01 m²)

N 1.02, N 3.02 (each 65,35 m²)

N 1.03, N 2.01, N 2.03, N 3.01 (each 99,73 m²)

N 2.02 (34,31 m²)

N 0.01 (5,62 m²)

CH (60,75 m²)

The parking garage will be solved acc. to annex 1 of ČSN 73 0804

4.3 Definition of fire hazard, degree of fire safety and evaluation of the fire sectors size

Fire sectors N 1.01, N 1.02, N 1.03, N 2.01, N 2.02, N 2.03, N 3.01, N 3.02, N 3.03

Fire load $p_v = 40,0 \text{ kg/m}^2$

Degree of fire safety II.

The border dimensions of the fire sectors with dwelling units are acc. ČSN 73 0833 not evaluated.

Fire sector N 0.01

$p_n = 2,2 \text{ (service room)} + 1,1 \text{ (clean-up room)} = 3,3 \text{ kg/m}^2$

$p_s = 2 \text{ (door)} + 5 \text{ (floors)} = 7 \text{ kg/m}^2$

$p = p_n + p_s = 10,3 \text{ kg/m}^2$

$a = 1,2$

$b = 1$

$$c = 0,75$$

$$p_v = p * a * b * c$$

$$p_v = 10,3 * 1,2 * 1 * 0,75 = \mathbf{9,27 \text{ kg/m}^2}$$

Degree of fire safety II.

Fire sector E

$$p_n = 25 \text{ kg/m}^2$$

$$p_s = 2 \text{ (door)} + 5 \text{ (floors)} + 3 \text{ (windows)} = 7 \text{ kg/m}^2$$

$$p = p_n + p_s = 10,3 \text{ kg/m}^2$$

$$a = 1,2$$

$$b = 1$$

$$c = 0,75$$

$$p_v = p * a * b * c$$

$$p_v = 32 * 1,2 * 1 * 0,75 = \mathbf{28,8 \text{ kg/m}^2}$$

Degree of fire safety II.

4.4 Fire resistance of the constructions requirements

Fire sectors N 1.01, N 1.02, N 1.03, N 2.01, N 2.02, N 2.03

Material	Demand – ČSN 730802	Actual value
External load-bearing wall Lime-sand blocks th. 240 mm 1 st floor	REW 30	REW 180 DP1
Internal load-bearing wall Lime-sand blocks th. 240 mm 1 st floor	REI 30	REI 180 DP1
Internal fire-resistant partition Plaster boards partition 2x Knauf white 12,5 mm 1 st floor	EI 30	EI 60 DP1
Ceilings monolithic fixed RC slabs above second and third floor	REI 30	<i>cover designed according to REI 30 DP1</i>
Fire door	EIS 15 D3	EIS 15 D3

Fire sectors N 3.01, N 3.02, N 3.03

Material	Demand – ČSN 730802	Actual value
External load-bearing wall Lime-sand blocks th. 240 mm 1 st floor	REW 15	REW 180 DP1
Internal load-bearing wall Lime-sand blocks th. 240 mm 1 st floor	REI 15	<i>cover designed according to REI 180 DP1</i>
Internal fire-resistant partition Plaster boards partition 2x Knauf white 12,5 mm 1 st floor	EI 15	EI 60 DP1
Ceilings monolithic fixed RC slabs above fourth floor	REI 15	<i>cover designed according to REI 15 DP1</i>
Fire door	EIS 15 D3	EIS 15 D3

Fire sector N 0.01

Material	Demand – ČSN 730802	Actual value
Internal load-bearing wall RC wall th. 300, 250 mm	REI 30	<i>cover according to REI 30 DP1</i> <i>designed</i>
Internal non load-bearing wall RC wall th. 150 mm	EI 30	<i>cover according to EI 30 DP1</i> <i>designed</i>
Ceilings monolithic fixed RC slabs above first floor	REI 30	<i>cover according to REI 30 DP1</i> <i>designed</i>
Fire door	EIS 15 D3	EIS 15 D3

Fire sector E

Material	Demand – ČSN 730802	Actual value
External load-bearing wall Lime-sand blocks th. 240 mm 1 st floor	REW 30	REW 180 DP1
Internal load-bearing wall Lime-sand blocks th. 240 mm 1 st floor	REI 30	REI 180 DP1
Internal load-bearing wall RC wall th. 240 mm 1 st floor	REI 30	<i>cover according to REI 30 DP1</i> <i>designed</i>
Stairs, landings monolithic RC construction	REI 30	<i>cover according to REI 30 DP1</i> <i>designed</i>
Fire door	EW 15 D3	EIS 15 D3

4.5 Escape routes

Acc to ČSN 730833 the structure meets description of buildings from the group OB2.

The evacuation of persons is provided with one protected escape route. The route is of type A. The route is ventilated with windows at each landing with enough area.

The entrance door to the building may open inside; their width is 1100 mm and they must allow easy passage.

The route has width 1250 mm. The smallest possible value is $1,5 \times \text{one escape strip} (1,5 * 550) = 1100 \text{ mm}$. $1250 > 1100 \text{ mm}$ therefore the escape route will suffice.

Length of the route is $< 120 \text{ m}$.

4.6 Fire hazardous area

The fire hazardous area from the structure's openings in the external wall of the fire sectors lead to the free space around the building ; it will not reach beyond the border of the building plot.

The existing nearby building will not be included in the fire hazardous area of the solved structure.

Safe distance acc. Table F. of ČSN 73 0802:

sector	fire load (kg/m ²)	area S _p		area S _{po} (m ²)	% open	safe distance (m)
		length l (m)	height h _u (m)			
north facade						
1_01	40	7,375	1,5	3	27	2,8
1_02	40	7,375	1,5	3	27	2,8
2_01	40	7,375	1,5	3	27	2,8
2_03	40	7,375	1,5	3	27	2,8
3_01	40	7,375	1,5	3	27	2,8
3_03	40	7,375	1,5	3	27	2,8
south facade						
1_01	40	4,75	2,4	6,15	54	4,4
1_02	40	9,08	2,4	12,075	55	4,5
1_03	40	9,45	2,4	12,225	54	4,5
2_01	40	9,45	2,4	12,225	54	4,5
2_02	40	4,2	1,5	5,25	83	4,4
2_03	40	9,45	2,4	12,225	54	4,5
3_01	40	9,45	2,4	12,225	54	4,5

3_02	40	9,08	2,4	12,075	55	4,5
3_03	40	4,75	2,4	6,15	54	4,4

east facade						
1_03	40	10,575	2,4	8,75	34	2,8
2_03	40	10,575	2,4	8,75	34	2,8
3_02	40	8,95	2,4	10,985	51	4
3_03	40	0,725	1,5	1,09	100	4,4
west facade						
1_01	40	0,725	1,5	1,09	100	4,4
1_02	40	8,95	2,4	10,985	51	4
2_01	40	10,575	2,4	8,75	34	2,8
3_01	40	10,575	2,4	8,75	34	2,8

4.6 Fire water supply

External fire water supply

The need of external fire water supply will be provided with existing fire water network within nearby communication (underground hydrants).

Internal fire water supply

Acc. Čsn 73 0873 hose systems connected to internal water supply must be installed. They must be permanently pressurized. The system must be controllable by one person and installed 1,2 m above floor height at each floor (4). Further information is defined in ČSN EN 671-1 standard.

4.7 Access

The structure is connected with existing public communication with two garage access roads (width = 4,4 m) and foot access to the building's entrance (width = 2 m). No special adjustments are required.

4.8 Mobile extinguishers

There will be one extinguisher in the escape route, one powder extinguisher by the central electric fuses and one extinguisher per apartment.

4.9 Technical equipment of the structure

- a) Ventilation – overall ventilation in the building is covered with natural ventilation through windows. Other forced ventilation is defined in the project documentation.
- b) Heating – the heating is provided with condensing boiler situated in the service room.
- c) Electric installations – will be installed acc. to latest standards regarding this problematic. The atmospheric electricity protection will be provided with external lightning protection.

4.10 Special requirements on building constructions

The hydrant boxes must be installed in a predrilled cavity in the masonry.

4.11 Requirements on automatic fire sensors

The structure is provided with automatic fire sensors (A1) acc. Decree 23/2008 Coll. This devices will be situated at each floor of stairwell as well as inside each fire sector. The further situation is defined in accompanying drawings.

5. Safety marks and tables

The escape route and fire water supply stations will be marked acc. ČSN ISO 3864, ČSN ISO 01 0813 and Decree 11/2002 Coll. with safety marks and tables.

5. Conclusion

The solved structure will suffice all fire safety requirements while keeping all prescribed constructions and solutions.

If a change in the overall design should take place the necessary adjustments of the fire safety evaluation must be processed.

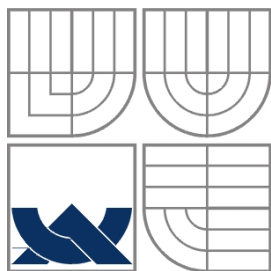

VYSOKÉ UČENÍ TECHNICKÉ V BRNĚ

BRNO UNIVERSITY OF TECHNOLOGY



FAKULTA STAVEBNÍ

ÚSTAV POZEMNÍHO STAVITELSTVÍ

FACULTY OF CIVIL ENGINEERING
INSTITUTE OF BUILDING STRUCTURES

D.1.4 – HEATING SYSTEM CONCEPT

DIPLOMOVÁ PRÁCE

MASTER'S THESIS

AUTOR PRÁCE

AUTHOR

BC. MARIAN HLAVICA

VEDOUCÍ PRÁCE

SUPERVISOR

doc. Ing. JIŘÍ SEDLÁK, CSc.

BRNO 2014

CONTENT OF FOLDER

D.1.4.1 Technical report

D.1.4.1 Drawings

- D.1.4.1-01 – Layout of typical floor
- D.1.4.1-02 – Scheme of riser R1
- D.1.4.1-03 – Scheme of riser R2
- D.1.4.1-04 – Scheme of riser R3
- D.1.4.1-05 – Scheme of riser R4

D.1.4.1 List of machinery



VYSOKÉ UČENÍ TECHNICKÉ V BRNĚ

BRNO UNIVERSITY OF TECHNOLOGY



FAKULTA STAVEBNÍ

ÚSTAV POZEMNÍHO STAVITELSTVÍ

FACULTY OF CIVIL ENGINEERING
INSTITUTE OF BUILDING STRUCTURES

D.1.4.1 TECHNICAL REPORT

DIPLOMOVÁ PRÁCE
MASTER'S THESIS

AUTOR PRÁCE
AUTHOR

BC. MARIAN HLAVICA

VEDOUCÍ PRÁCE
SUPERVISOR

doc. Ing. JIŘÍ SEDLÁK, CSc.

BRNO 2014

Content

1. Identification	3
2. List od used information sources	3
3. General information	3
3.1 Brief construction description	3
3.2 Disposition description	4
4. Thermal properties	4
4.1 Climatic area	4
4.2 Internal temperatures and ventilation.....	4
4.3 Thermal properties of the structure.....	4
5. Heat source.....	5
5.1 Primary energy.....	5
5.2 Heat source and hot water preparation.....	5
5.3 Chimney.....	5
5.4 Flue gas outlet.....	5
6. Heating system.....	5
6.1 Heating system description	5
6.2 Pressure.....	6
6.3 Filling and discharge of the system	6
6.4 Radiators.....	6
6.5 Thermal insulation of the conducts	6
6.6 Hot water preparation.....	6
7. Requirements on proffesions.....	6
7.1 Construction works.....	6
7.2 Electric installations.....	6
7.3 Building services	6
7.4 Gas supply	7
8. Installation and initiation of the system	7
8.1 Machinery, heating system, hot water preparation.....	7
8.2 Heating test, pressure test, dilatation test.....	7
8.3 Control	7
9. Health and environment protection	7
10. Hazard avoiding	7

1. Identification

Construction name: Low energy block of apartments

Address: Karla Schinzela street, Rýmařov, 795 01

Cadastral area: Rýmařov

Degree of project documentation: Heating system concept

Type of construction: New construction

Investor: Jan Novák

Investor's address: Slunečná 68, Rýmařov 795 01

Author: Bc. Marian Hlavica

2. List of used information sources

As the information sources for the heating system concept documentation processing were used these sources:

- Project documentation – architectonic-construction part
- Project documentation – calculations of heat transfer coefficient for structure's compositions
- ČSN EN 12831
- ČSN 06 0210
- ČSN 73 0540
- ČSN 01 3452
- ČSN 73 4201
- Information from manufacturers of proposed machinery

3. General information

3.1 Brief construction description

The project solves construction of a low energy block of apartments which is a single building with three floors above ground and one partially underground (acc. to ČSN 73 0802 regarded as above ground) floor with open collective garage. The underground floor's load-bearing construction is formed with reinforced concrete walls. The rest of the vertical load-bearing

constructions is formed with lime-sand masonry except for the elevator shaft construction which is of reinforced concrete.

The external walls are thermally insulated with ETICS system. The internal parking garage is also thermally separated from the heated part of the structure with ETICS system.

3.2 Disposition description

The solved construction consists of an partially depressed floor with parking garage, trolley storage, bicycle storage, utility room, service room and building clean-up room in the und. floor. In the rest of the building there are three flats per each floor above ground, corridor, stairwell and elevator shaft. There are four two-room flats, four room-flats and one studio.

The designed number of permanent inhabitants is 25.

4. Thermal properties

4.1 Climatic area

Place: Rýmařov

Height above sea level: 610.1 m

Design external temperature (acc. ČSN 12 831): - 18 °C

4.2 Internal temperatures and ventilation

Dwelling areas: 20°C

Bathrooms: 24°C

Halls, corridors inside apartments: 15°C

Storages, stairwell, corridors outside apartments: 10°C

The ventilation in the building is designed as natural.

4.3 Thermal properties of the structure

Designed thermal properties are calculated according to proposed compositions of constructions and their thermal properties acc. ČSN 73 0540-2:2011, ČSN 73 0540-3:2005.

Heat losses calculation for individual rooms is attached at the end of the document.

The overall design heat loss of the typical floor is calculated to be **10939,793 W**. The total heat loss of the structure is calculated to be **38289,276 W**.

5. Heat source

5.1 Primary energy

The heat production and production of hot water for the building is provided with condensing boilers. The boilers are intended to burn natural gas. The gas supply will be provided through connection to the public low pressure gas network.

5.2 Heat source and hot water preparation

The heat source for the heating system demand of **43560,49 W** will be:

- 1 x Condensing boiler Buderus Logamax plus GB162-45, P=45kW

The hot water preparation source will be:

- 1 x Condensing boiler Buderus Logamax plus GB172-24, P=24kW

Both boilers will be of a type C – TURBO, the burning air supply will be provided with doubled pipe of diameter 80/125 as prescribed by manufacturer. In the summer season while only the hot water preparation will take place the GB162-45 boiler will be inactive.

5.3 Chimney

Classic chimney will not be installed

5.4 Flue gas outlet

The flue gas outlet from each boiler will be provided with the above mentioned doubled pipe 80/125 through the roof construction and finished above the wind angle of the nearby elevator shaft. The position and height of the pipe outlet is defined in the project documentation (P.E.: Drawing D.1.1-11 – Sectional elevation A-A')

6. Heating system

6.1 Heating system description

The medium of the system will be water with forced flow and temperature difference 55/45 °C.

It will be divided into four risers according to different dispositional parts of the structure. All conducts will be made of copper piping joined with soldering; they will be lead in floor and building constructions.

6.2 Pressure

The pressurizing of the system will be provided through internal pump of the condensing boiler defined in the technical documentation of the manufacturer.

6.3 Filling and discharge of the system

Filling of the heating system will be provided with potable water of the internal water supply of the structure through system of automatic water supply situated in the service room. It will consist of pipe separator which will provide safe separation of the potable water supply and the heating system. There will be also automatic water treatment station. The system discharge will be provided through discharge valve and through valves on the radiators.

6.4 Radiators

The heating system will be controlled with equitherm system of regulation. All radiators will be provided with thermo-static valves and thermo-static heads. The exact types of the radiators are in the annex at the end of the document.

6.5 Thermal insulation of the conducts

All the piping lead in the floor will be provided with thermal insulation isoform th. 9mm, $\lambda = 0,039$ w/mk. The piping leading through parking garage will be provided with thermal insulation isoform th. 50 mm, $\lambda = 0,039$ w/mk.

6.6 Hot water preparation

The hot water preparation is provided with Condensing boiler Buderus Logamax plus GB172-24 in combination with water storage tank REGULUS RBC 1000, V=1000 l.

7. Requirements on professions

7.1 Construction works

The penetration of structural walls will be made about 30 mm bigger than the conducts diameter. The risers will be situated in central shafts of the structure.

7.2 Electric installations

The electricity supply for the machinery will be solved in specialized documentation.

7.3 Building services

The water storage tank must be connected with potable water supply and hot water network of the building. The potable water supply must be provided for the heating system filling.

Floor inlet discharge and discharge of the boiler's condensate must be provided in the service room.

7.4 Gas supply

Connection of the boilers to the gas supply is necessary.

8. Installation and initiation of the system

8.1 Machinery, heating system, hot water preparation

The installation and initiation of the machinery as well as heating system and hot water preparation system must be processed by educated person according to the manufacturer's prescription.

8.2 Heating test, pressure test, dilatation test

Initiation of the heating system requires processing of the tightness test and the dilatation and heating test acc. ČSN 06 0310. The dilatation test will be processed with double heating of the system to the maximum working temperature and its cooling. There must not occur any not-tightness or other problem. The heating test will require double flooding of the system with hot water. It will be processed during 24 h.

The pressure test will be processed with pressure 300 kPa. The result will suffice if no visible leakage is observed and the test over-pressure will not drop.

8.3 Control

The system must be controlled by educated person only provided with manuals of the machinery.

9. Health and environment protection

The systems and machinery in the building will not cause decay of the environment.

All of the possible waste produced during installation, initiation and operation of the systems and machinery must be dealt with acc. law 185/2001 Coll.

10. Hazard avoiding

Only educated persons may install, initiate and control the machinery and the heating and hot water preparation systems.

The law 262/2006 Coll. and Decree 324/1990 coll. must be followed at all times.

Technické parametry

Logamax plus GB162 (15 – 45 kW)

Logamax plus	GB162-15	GB162-25	GB162-35	GB162-45
Tepelný výkon (kW)	2.7 – 15.2	4.8 – 24.9	5.8 – 32.7	10.4 – 44.9
Normovaný stupeň využití (%)	až 110.5			
Teplota otopné vody (°C)	až 82			
Průměr spalínového potrubí (mm)	80 / 125			
Elektrický příkon (W)	28 – 58	37 – 70	51 – 95	53 – 145
Rozměry V / Š / H (mm)	695 / 520 / 465			
Hmotnost (kg)	45	45	48	48
Třída NOx	5			

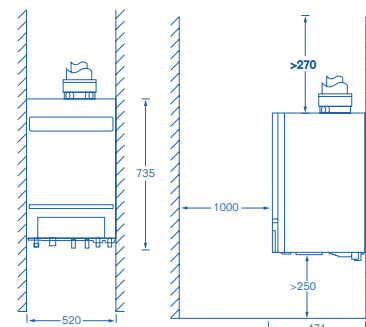
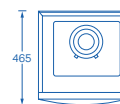

Logamax plus GB162 se zásobníkem s vrstveným nabíjením (25 kW)

Logamax plus	GB162-25 T40 S
Tepelný výkon (kW)	4.8 – 24.9
Výkon pro ohřev teplé vody (kW)	33.4
Normovaný stupeň využití (%)	až 110.5
Teplota otopné vody (°C)	až 82
Průměr spalínového potrubí (mm)	80 / 125
Teplota teplé vody (°C)	30 až 60
Elektrický příkon (W)	37 – 109
Rozměry V / Š / H (mm)	695 / 920 / 465
Hmotnost (kg)	70
Množství teplé vody při 80/45/10 °C (l/h)	825
Třída NOx	5

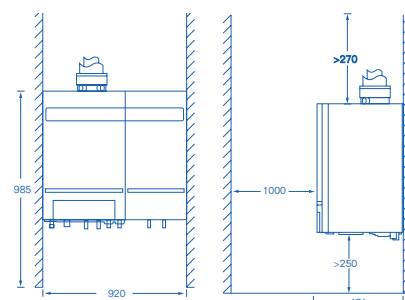

Topenářská prodejní centra Buderus

Topenářské centrum Praha
Sídlo obchodní divize Buderus pro ČR
 Průmyslová 372/1
 108 00 Praha 10 – Štěrboholy
 tel.: +420 272 191 110
 e-mail: prodejpraha@buderus.cz

Topenářské centrum Hradec Králové
 Bratří Štefanů 499
 500 03 Hradec Králové
 tel.: +420 495 544 182
 mobil: +420 721 210 935
 e-mail: prodejkhk@buderus.cz

Prodejní sklad České Budějovice
 Nemanická 5
 370 10 České Budějovice
 tel.: +420 387 330 699
 mobil: +420 720 168 198
 e-mail: prodejcb@buderus.cz

Topenářské centrum Ústí n/Labem
 Přístavní 432/8
 400 07 Ústí nad Labem
 tel.: +420 475 208 574
 mobil: +420 721 210 936
 e-mail: prodejul@buderus.cz

Topenářské centrum Prostějov
 Háj 327
 798 12 Kralice na Hané
 tel.: +420 582 302 911
 mobil: +420 724 269 963
 e-mail: prodejpv@buderus.cz

Topenářské centrum Plzeň
 Koterovská 177
 326 00 Plzeň
 tel.: +420 377 535 938
 mobil: +420 721 111 055
 e-mail: prodejplzen@buderus.cz

Topenářské centrum Ostrava
 Novinářská 1254/7
 709 00 Ostrava – Mariánské Hory
 tel.: +420 591 133 833
 mobil: +420 702 003 598
 e-mail: prodejov@buderus.cz

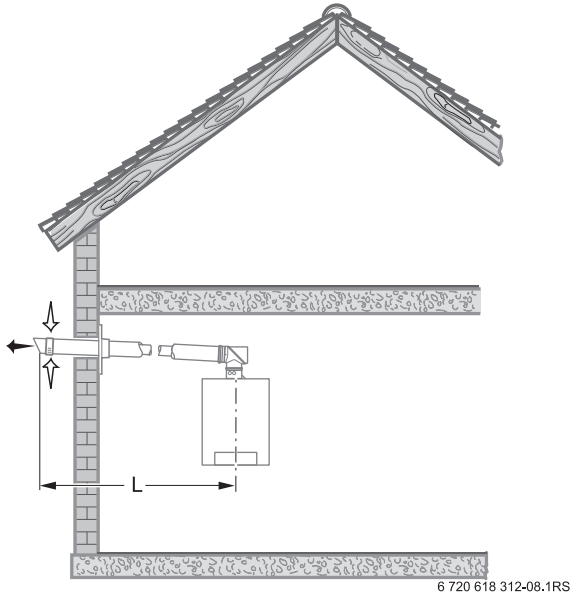
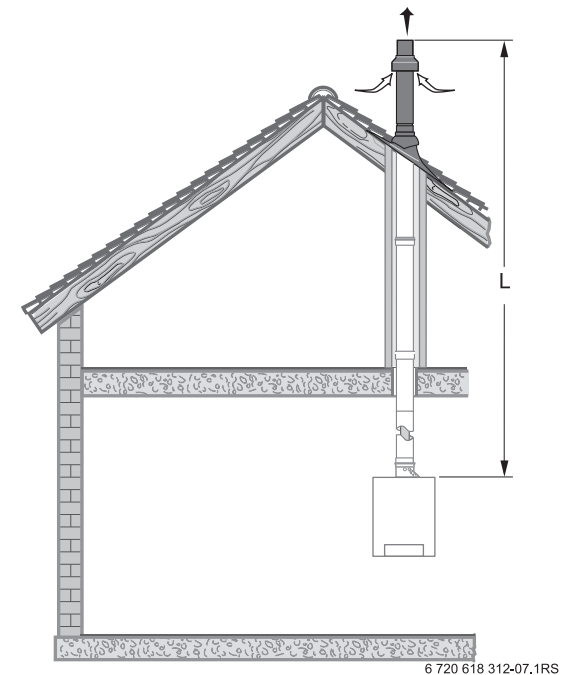

5.3.2 Spalinové systémy pro provoz nezávislý na vzduchu z prostoru

Konstrukční typ	Popis	Schematické znázornění	Typ kotle GB162	Výpočetní délky		
				L [m]	87° [m]	15-45° [m]
C _{13x}	<p>Vedení přívodu spalovacího vzduchu/odtahu spalin Ø 80/125 mm vodorovně vnější stěnou. Obě vyústění se nalézají nedaleko od sebe v téže tlakové oblasti.</p> <p>V Německu není přípustné (→ kapitola 3.3). Dodržujte platné místní normy a předpisy.</p>	 <p style="text-align: right; font-size: small;">6 720 618 312-08.1RS</p>	-15	4*	0*	
			-25	4*	0*	
			-25 T10	4*	0*	
			-30 T10	4*	0*	
			-25 T40S	4*	0*	
			-30 T40S	4*	0*	
			-35	4*	0*	
			-45	4*	0*	
			*platí maximálně pro 3 přidaná kolena.			
C _{33x}	<p>Vedení spalovacího vzduchu/odtahu spalin Ø 80/125 mm svisle střechou. Obě vyústění se nalézají nedaleko od sebe v téže tlakové oblasti.</p>	 <p style="text-align: right; font-size: small;">6 720 618 312-07.1RS</p>	Šachta Ø 160 mm □ 160 mm	-15	11	0*
			-25	19	1,5	0,5
			-25 T10	19	1,5	0,5
			-30 T10	19	1,5	0,5
			-25 T40S	19	1,5	0,5
			-30 T40S	19	1,5	0,5
			-35	14	1,5	0,5
			-45	11	1,5	0,5
			*platí maximálně pro 3 přidaná kolena.			

Tab. 13 Možnosti instalace



Logamax plus	GB172-14	GB172-24	GB172-24K
Jmenovitý modulovaný výkon [kW]	2,9 -14	6,6-23,8	6,6-23,8
Normovaný stupeň využití [%]	až 109	až 109	až 109
Výkon teplé vody [kW]	15,1	29,7	29,7
Průměr spalinového potrubí [mm]	80/125	80/125	80/125
Teplota teplé vody [°C]	40-60	40-60	40-60
Elektrický příkon [W]	max. 65	max. 75	max. 75
Výška x šířka x hloubka [mm]	840x440x350	840x440x350	840x440x350
Hmotnost [kg]	43	43	44



Zásobník teplé vody Logalux	H65W	WU120W	WU160W
Výška [mm]	840	942	942
Šířka [mm]	440	500	500
Hmotnost [kg]	47	50	60



Zásobník teplé vody Logalux	S120	SU160W	SU200W	SU300W
Výška [mm]	956	1188	1448	1465
Šířka [mm]	512	558	556	672
Hmotnost [kg]	72	98	110	145



Zásobník teplé vody Logalux	SM300
Výška [mm]	1465
Šířka [mm]	672
Hmotnost [kg]	155

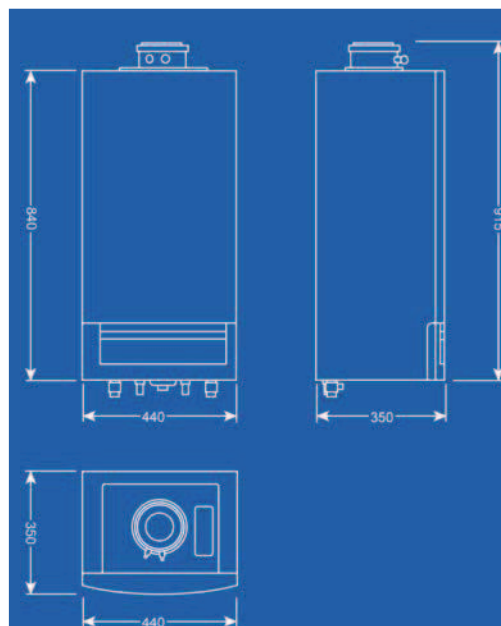

Vysoce vyvinutá technologie a vysoký technický standard vyžadují profesionální instalaci a údržbu. Kompletní program výrobků značky Buderus je dodáván prostřednictvím odborných a specializovaných firem. Bosch Termotechnika s.r.o., obchodní divize Buderus, poskytuje všem zájemcům vyčerpávající informace a zajišuje odborná školení a semináře.

Váš kompetentní partner v oblasti vytápění:

Bosch Termotechnika s.r.o.
 obchodní divize Buderus
 Průmyslová 372/1, 108 00 Praha 10 - Štěrboholy
 Tel.: 272 191 111, Fax: 272 700 618
 E-mail: info@buderus.cz; www.buderus.cz

Buderus

Zásobníkový ohřivač teplé vody RBC 1000

kód: 4038

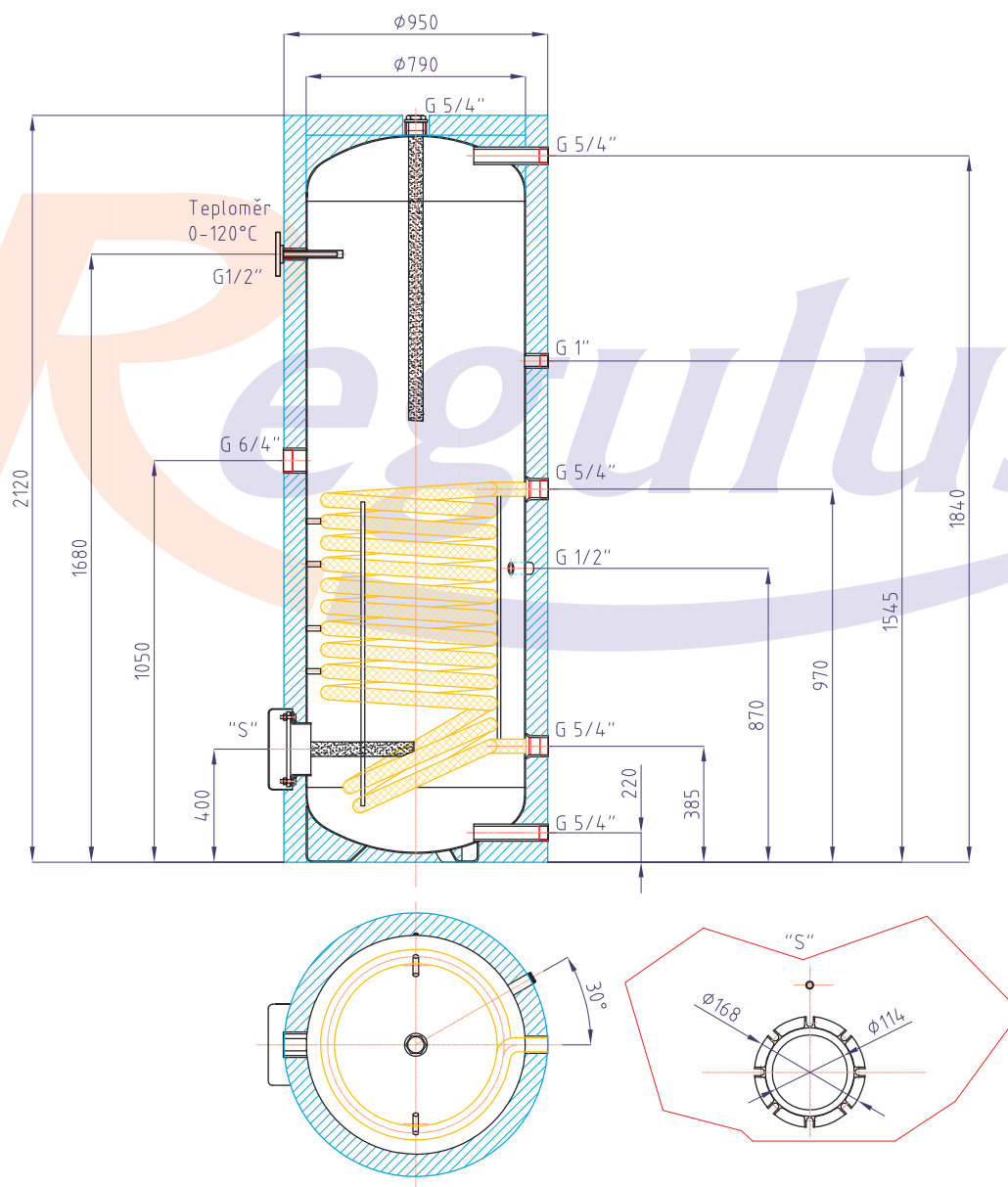

Celkový objem kapalin v zásobníku včetně výměníku	1000 l
Objem kapaliny v zásobníku	980 l
Objem kapaliny ve výměníku	20 l
Plocha výměníku	3,5 m ²
Maximální provozní teplota v zásobníku	95 °C
Maximální provozní teplota ve výměníku	110 °C
Maximální provozní tlak v zásobníku	10 bar
Maximální provozní tlak ve výměníku	10 bar
Příprava TV z 10 °C na 45 °C při teplotě ot.vody 60 °C	2860 l/h (116 kW)
Hmotnost prázdného zásobníku	262 kg
Klopná výška při sundané izolaci	2161 mm

ROBC

RGC

RBC

RBC HP

NBC

R2DC

R2GC

R2BC

N2BC

HSK

DUO E

DUO E2

PS

PS2F

PSWF

Výměníky

Příslušenství

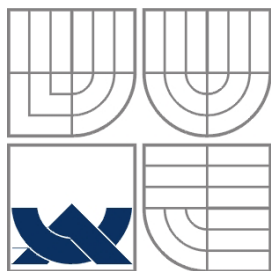

VYSOKÉ UČENÍ TECHNICKÉ V BRNĚ

BRNO UNIVERSITY OF TECHNOLOGY



FAKULTA STAVEBNÍ

ÚSTAV POZEMNÍHO STAVITELSTVÍ

FACULTY OF CIVIL ENGINEERING
INSTITUTE OF BUILDING STRUCTURES

E – OTHER DOCUMENTS

DIPLOMOVÁ PRÁCE
MASTER'S THESIS

AUTOR PRÁCE
AUTHOR

BC. MARIAN HLAVICA

VEDOUCÍ PRÁCE
SUPERVISOR

doc. Ing. JIŘÍ SEDLÁK, CSc.

BRNO 2014



CONTENT OF FOLDER

- E.1 – Statement of energy efficiency
- E.2 – Energy label
- E.3 – Geological survey
- E.4 - Calculations

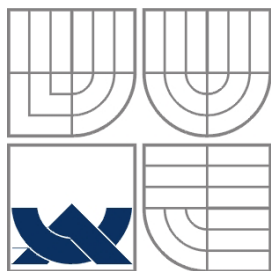

VYSOKÉ UČENÍ TECHNICKÉ V BRNĚ

BRNO UNIVERSITY OF TECHNOLOGY



FAKULTA STAVEBNÍ

ÚSTAV POZEMNÍHO STAVITELSTVÍ

FACULTY OF CIVIL ENGINEERING
INSTITUTE OF BUILDING STRUCTURES

E.1 – STATEMENT OF ENERGY EFFICIENCY

DIPLOMOVÁ PRÁCE
MASTER'S THESIS

AUTOR PRÁCE
AUTHOR

BC. MARIAN HLAVICA

VEDOUCÍ PRÁCE
SUPERVISOR

doc. Ing. JIŘÍ SEDLÁK, CSc.

BRNO 2014

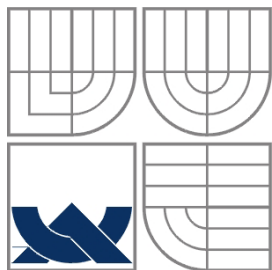

VYSOKÉ UČENÍ TECHNICKÉ V BRNĚ

BRNO UNIVERSITY OF TECHNOLOGY

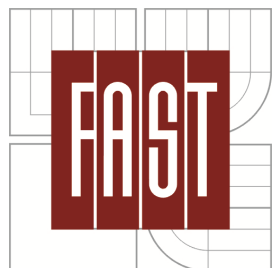

FAKULTA STAVEBNÍ

ÚSTAV POZEMNÍHO STAVITELSTVÍ

FACULTY OF CIVIL ENGINEERING
INSTITUTE OF BUILDING STRUCTURES

E.3 - GEOLOGICAL SURVEY

DIPLOMOVÁ PRÁCE

MASTER'S THESIS

AUTOR PRÁCE

AUTHOR

BC. MARIAN HLAVICA

VEDOUCÍ PRÁCE

SUPERVISOR

doc. Ing. JIŘÍ SEDLÁK, CSc.

BRNO 2014

Content

1. Used materials	3
2. Summary of geological and hydro-geological state	3
3. Geotechnical properties of rocks (CSN 73 1001)	3
4. Geological evaluation.....	4

1. Used materials

- The geologic map of ČSSR, the map of pre-quaternary objects, scale 1 : 200 000, page M-33-XXIV, Olomouc

- The geologic map of Czech Republic, scale 1 : 50 000, no. 14-42 Rýmařov

2. Summary of geological and hydro-geological state

Pre-quaternary basis in the investigated area is formed with rocks of Devon – flyshoid rock (top devon) which is here presented with chloritic and muscovite-chloritic phyllites, the green slate. The mentioned rocks are ascend to the surface of the area.

The underground water is connected with the cleft system in the bigger depths.

The presumed geological profile:

	Acc. CSN 73 1001	Acc. CSN 73 3050
0,0 – 0,6 m – top soil, compacted	F5MLY	3
0,6 – 1,5 m – phyllite muscovite-chloritic, weathered to less weathered	R4	5
1,5 – x - DTTO less weathered	R3	6

The underground water is connected with the cleft system in the bigger depths (cca 10 m).

3. Geotechnical properties of rocks (CSN 73 1001)

3.1 phyllite muscovite-chloritic weathered to less weathered belongs to the R4 class:

Compressive strength $\sigma_c = 15 \text{ MPa}$

Modulus of shape-ability $E_{\text{def}} = 250 \text{ MPa}$

Poisson's number $\vartheta = 0,25$

Design load carrying capacity $R_{\text{dt}} = 0,4 \text{ MPa}$

3.2 phyllite muscovite-chloritic weathered belongs to the R3 class:

Compressive strength $\sigma_c = 25 \text{ MPa}$

Modulus of shape-ability $E_{\text{def}} = 600 \text{ MPa}$

Poisson's number $\vartheta = 0,2$

4. Geological evaluation

These geological conditions can be classified as simple. The designed structure (low-energy block of apartments) is not foundation - demanding. While designing foundations in simple geological conditions the first geo-technologic category is followed:

The tabled design load-bearing capacity is used:

$R_{\text{dt}} = 0,4 \text{ Mpa}$

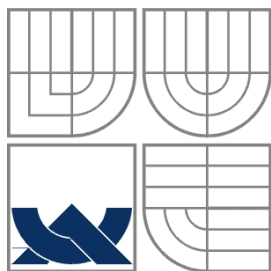

VYSOKÉ UČENÍ TECHNICKÉ V BRNĚ

BRNO UNIVERSITY OF TECHNOLOGY



FAKULTA STAVEBNÍ

ÚSTAV POZEMNÍHO STAVITELSTVÍ

FACULTY OF CIVIL ENGINEERING
INSTITUTE OF BUILDING STRUCTURES

E.4 - CALCULATIONS

DIPLOMOVÁ PRÁCE

MASTER'S THESIS

AUTOR PRÁCE

AUTHOR

BC. MARIAN HLAVICA

VEDOUCÍ PRÁCE

SUPERVISOR

doc. Ing. JIŘÍ SEDLÁK, CSc.

BRNO 2014

Preliminary design of foundation pad - most loaded case

Permanent load					
	a	d	b	ρ	N / m
Masonry (4)					
Lime-sand blocks	0,25	2,5	6,65	2000,00	83125,00
Internal plaster	0,012	2,6	6,65	1800,00	3734,64
RC Rings	0,25	0,2	6,65	2500,00	8312,50
				Sum:	95172,14
				* 3 floors:	285516,42
Ceiling construction (4)					
RC Slab	3,3375	0,18	5,1875	2500,00	77909,77
Plaster	3,3375	0,012	5,1875	1800,00	3739,67
				Sum:	81649,43
				* 4 ceilings	326597,74
Floors (3)					
Acoustic insulation	3,3375	0,05	5,1875	85,00	735,81
Floor construction	3,3375	0,05	5,1875	1200,00	10387,97
				Sum:	11123,78
				* 3 floors	44495,13
Roof construction (1)					
Thermal insulation	3,3375	0,45	5,1875	23,00	1791,92
				Sum:	1791,92
RC LB construction (1)					
Main beam	5,1875	0,4	0,375	2500,00	19453,13
Secondary beam	1,4	0,4	0,375	2500,00	5250,00
Column	0,375	2,425	0,375	2500,00	8525,39
TI	5,1875	0,15	3,3375	23,00	597,31
				Sum:	33825,82
Self-weight (1)					
RC pad	1,8	0,975	1,8	2500,00	78975,00
				Sum:	78975,00
TOTAL PERMANENT LOAD					
771202,04	N / m				

Variable load					
	a	b	N / m ²	N	
Snow load (1)					
Snow	3,3375	5,1875	2500	43283,20	
			Sum:	43283,20	
Imposed load on floors (3)					
Imposed load	3,3375	5,1875	1500	25969,92	
			Sum:	25969,92	
			* 3 floors	77909,77	
Imposed load on roof (1)					
Imposed load	3,3375	5,1875	100	1731,33	
			Sum:	1731,33	
TOTAL VARIABLE LOAD					
122924,30	N / m				

COMBINATION 6.10 acc. To EUROCODE 2					
1,35 * permanent load + 1,5 * variable load					
calculation:	1,35	*	771202,04	+	1,50 * 122924,30
=	1225509,198 N				
STRESS ON SOIL					
σ	=	378243,58	Pa	<	Rdt = 400 000 Pa
Pad dimensions:					
a =	1,8	m			
b =	1,8	m			
d =	0,975	m			

Preliminary design of foundation strip - most loaded case

Permanent load

	b	d	ρ	N / m
Masonry (3)				
Lime-sand blocks	0,25	2,5	2000	12500,00
Internal plaster	0,012	2,6	1800	561,60
RC Rings	0,25	0,2	2500	1250,00
			Sum:	14311,60
			* 3 floors:	42934,80
Ceiling construction (4)				
RC Slab	4,8125	0,18	2500	21656,25
Plaster	4,5625	0,012	1800	985,50
			Sum:	22641,75
			* 4 ceilings	90567,00
Floors (3)				
Acoustic insulation	4,8125	0,05	85	204,53
Floor construction	4,8125	0,05	1200	2887,50
			Sum:	3092,03
			* 3 floors	12368,13
Roof construction (1)				
Thermal insulation	4,8125	0,45	23	498,09
			Sum:	498,09
RC Wall				
RC Wall	0,3	2,5	2500	18750,00
Internal plaster	0,012	2,6	1800	561,60
			Sum:	19311,60
TI in garage (1)				
Thermal insulation	4,8125	0,15	23	166,03
			Sum:	166,03
Self-weight (1)				
RC foundation strip	0,8	1,05	2500	21000,00
			Sum:	21000,00
TOTAL PERMANENT LOAD				
186845,65	N / m			

Variable load				
	b	N / m ²	N / m	
Snow load (1)				
Snow	4,8125	2500	12031,25	
		Sum:	12031,25	
Imposed load on floors (3)				
Imposed load	4,8125	1500	7218,75	
		Sum:	7218,75	
		* 3 floors	21656,25	
Imposed load on roof (1)				
Imposed load	4,8125	100	481,25	
		Sum:	481,25	
TOTAL VARIABLE LOAD				
34168,75	N / m			

COMBINATION 6.10 acc. To EUROCODE 2				
1,35 * permanent load + 1,5 * variable load				
calculation:	1,35	*	186845,65	+ 1,5 * 34168,75
=	303494,8 N			
STRESS ON SOIL				
	σ = 379368	Pa	<	Rdt = 400 000 Pa
Strip dimensions:				
a =	0,8	m		
d =	1,05	m		

Preliminary design of column - most loaded case

Permanent load

	a	d	b	ρ	N / m
Masonry (4)					
Lime-sand blocks	0,25	2,5	6,65	2000,00	83125,00
Internal plaster	0,012	2,6	6,65	1800,00	3734,64
RC Rings	0,25	0,2	6,65	2500,00	8312,50
				Sum:	95172,14
				* 3 floors:	285516,42
Ceiling construction (4)					
RC Slab	3,3375	0,18	5,1875	2500,00	77909,77
Plaster	3,3375	0,012	5,1875	1800,00	3739,67
				Sum:	81649,43
				* 4 ceilings	326597,74
Floors (3)					
Acoustic insulation	3,3375	0,05	5,1875	85,00	735,81
Floor construction	3,3375	0,05	5,1875	1200,00	10387,97
				Sum:	11123,78
				* 3 floors	44495,13
Roof construction (1)					
Thermal insulation	3,3375	0,45	5,1875	23,00	1791,92
				Sum:	1791,92
RC LB construction (1)					
Main beam	5,1875	0,4	0,375	2500,00	19453,13
Secondary beam	1,4	0,4	0,375	2500,00	5250,00
TI	5,1875	0,15	3,3375	23,00	597,31
				Sum:	25300,43
TOTAL PERMANENT LOAD					
683701,65	N / m				

Variable load					
	a	b	N / m2	N	
Snow load (1)					
Snow	3,3375	5,1875	2500	43283,20	
			Sum:	43283,20	
Imposed load on floors (3)					
Imposed load	3,3375	5,1875	1500	25969,92	
			Sum:	25969,92	
			* 3 floors	77909,77	
Imposed load on roof (1)					
Imposed load	3,3375	5,1875	100	1731,33	
			Sum:	1731,33	
TOTAL VARIABLE LOAD					
122924,30	N / m				

COMBINATION 6.10 acc. To EUROCODE 2					
	1,35 * parmanent load + 1,5 * variable load				
calculation:	1,35	*	683701,65	+	1,50 * 122924,30
=	1107383,67 N				

Acc. To EUROCODE 2:

Preliminary design of the GIRDER with the longest span:

$$l = 5,075 \text{ m}$$

$$h = l/12 - l/8 \Rightarrow 5,075 / 10 = 0,5075 \text{ m}$$

$$h = 0,53 \text{ m}$$

$$b = (0,33 - 0,5) * h \Rightarrow 0,5 * 0,53 = 0,265$$

$$b = 0,3 \text{ m}$$

Preliminary design of most loaded COLUMN:

$$A_c = N_d / (f_{cd} + \rho * f_{yd}) = 1107383,67 / (20 * 10^6 + 0 * 434,78 * 10^6) = 0,0554 \text{ m}^2$$

$$a = 0,0554^{0,5} = 0,235 \text{ m}$$

$$a = 0,3 \text{ m}$$

Preliminary design of AIR CONDITIONING – SOUTHERN SHAFT

Acc. To ČSN EN 15665/Z1 (tab.1) the minimum needed air-flow for bathrooms is 50 m³/h, for WC 25 m³/h.

Assuming usage of 3 bathrooms with WC for 1 hour per day by 10 persons and 3 WCs for 0,5 hour per day by 10 persons.

$$365 * 10 * 1 + 365 * 10 * 0,5 = 5475 \text{ hours per anné.}$$

Acc. Directive VDI no. 3803 (tab. 1) for usage hours 3000-6000 per anné the air-flow velocity should not exceed 2,5 m/s.

For rectangular cross-section **160 x 400**, $A = 0,064 \text{ m}^2$

The total needed air-flow equals: $3 \times 50 + 3 * 25 = 225 \text{ m}^3/\text{h}$

$$225 / 0,064 * 3600 = \mathbf{0,977 \text{ m/s}}$$

The velocity of air-flow then equals: $0,977 \text{ m/s} < 2,5 \text{ m/s}$

Preliminary design of AIR CONDITIONING – EASTERN AND WESTERN SHAFT

Acc. To ČSN EN 15665/Z1 (tab.1) the minimum needed air-flow for bathrooms is 50 m³/h, for WC 25 m³/h.

Assuming usage of 3 bathrooms with WC for 1 hour per day by 5 persons and usage of building clean-up room 0,3 hour per day, the sum equals:

$$365 * 5 + 365 * 0,3 = 1934,5 \text{ hours per anné.}$$

Acc. Directive VDI no. 3803 (tab. 1) for usage hours 1500-3000 per anné the air-flow velocity should not exceed 3,0 m/s.

For rectangular cross-section **110 x 225**, $A = 0,0248 \text{ m}^2$

The total needed air-flow equals: $3 \times 50 + 1 * 25 = 175 \text{ m}^3/\text{h}$

$$175 / 0,0248 * 3600 = \mathbf{1,96 \text{ m/s}}$$

The velocity of air-flow then equals $1,96 \text{ m/s} < 3,0 \text{ m/s}$

Calculation of heat transfer coefficient acc. ČSN 73 0540 - 2 and ČSN 73 0540 - 3

EXTERNAL WALL				
Layer	d	λk	λd	R
External plaster	0,002	0,700	0,880	0,002
Mortar	0,004	0,860	0,970	0,004
EPS 70 F	0,170	0,039	0,040	4,250
Mortar	0,004	0,860	0,970	0,004
Limesand block	0,240	0,610	0,610	0,393
Internal plaster	0,012	0,880	0,990	0,012
Rse =	0,040			
Rsi =	0,250			
R =	4,666			
U =	0,202			
Ureq =	0,300			
Urec =	0,250			

ROOF				
Layer	d	λk	λd	R
Water-proofing	0,002	0,160	0,160	0,009
Separation	-	-		0,000
EPS 150 S	0,220	0,035	0,035	6,286
Vapour barrier	0,008	0,210	0,210	0,038
RC slab	0,180	1,480	1,740	0,103
Internal plaster	0,012	0,880	0,990	0,012
Rse =	0,040			
Rsi =	0,100			
R =	6,449			
U =	0,152			
Ureq =	0,240			
Urec =	0,160			

FLOOR ON SOIL				
Layer	d	λk	λd	R
EPS 200 S	0,100	0,033	0,033	3,030
Separation	-	-	-	0,000
Load-distribution I.	0,035	0,210	0,240	0,146
Mortar	0,005	0,860	0,970	0,005
Ceramic tile	0,010	0,340	0,340	0,029
Rse =	0,040			
Rsi =	0,170			
R =	3,211			
U =	0,292			
Ureq =	0,450			
Urec =	0,300			

FLOOR TO UNHEATED SPACE				
Layer	d	λk	λd	R
Internal plaster	0,002	0,880	0,990	0,002
Mortar	0,004	0,860	0,970	0,004
MW	0,090	0,039	0,041	2,195
Mortar	0,003	0,860	0,970	0,003
RC slab	0,180	1,480	1,740	0,103
Accoustic insulation	0,050	0,043	0,049	1,020
Load-distribution l.	0,035	0,210	0,240	0,146
Mortar	0,005	0,860	0,970	0,005
Ceramic tile	0,010	0,340	0,340	0,029
Rse =	0,040			
Rsi =	0,170			
R =	3,509			
U =	0,269			
Ureq =	0,600			
Urec =	0,400			

WALL TO UNHEATED SPACE				
Layer	d	λk	λd	R
Internal plaster	0,002	0,880	0,990	0,002
Mortar	0,004	0,860	0,970	0,004
MW	0,090	0,039	0,041	2,195
Mortar	0,004	0,860	0,970	0,004
RC Wall	0,150	1,480	1,740	0,086
Internal plaster	0,012	0,880	0,990	0,012
Rse =	0,040			
Rsi =	0,250			
R =	2,304			
U =	0,386			
Ureq =	0,600			
Urec =	0,400			

BUILDNG FOOT				
Layer	d	λk	λd	R
External plaster	0,002	0,700	0,880	0,002
Mortar	0,004	0,860	0,970	0,004
XPS	0,090	0,034	0,034	2,647
Mortar	0,004	0,860	0,970	0,004
Limesand block	0,240	0,610	0,610	0,393
Internal plaster	0,012	0,880	0,990	0,012
Rse =	0,040			
Rsi =	0,250			
R =	3,063			
U =	0,298			
Ureq =	0,300			
Urec =	0,250			

GARAGE FLOOR ON SOIL				
Layer	d	λ_k	λd	R
Load-distribution I.	0,150	1,480	1,740	0,086
Rse =	0,040			
Rsi =	0,170			
R =	0,086			
U =	3,376			
Ureq =	-			
Urec =	-			

GARAGE EXTERNAL WALL				
Layer	d	λ_k	λd	R
External plaster	0,002	0,700	0,880	0,002
Mortar	0,004	0,860	0,970	0,004
RC WALL	0,250	1,480	1,740	0,144
Internal plaster	0,012	0,880	0,990	0,012
Rse =	0,040			
Rsi =	0,250			
R =	0,162			
U =	2,211			
Ureq =	-			
Urec =	-			

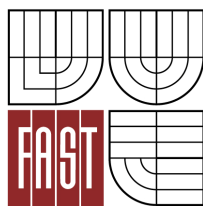

VYSOKÉ UČENÍ TECHNICKÉ V BRNĚ
FAKULTA STAVEBNÍ

POPISNÝ SOUBOR ZÁVĚREČNÉ PRÁCE

Vedoucí práce doc. Ing. Jiří Sedlák, CSc.

Autor práce Bc. Marian Hlavica

Škola Vysoké učení technické v Brně

Fakulta Stavební

Ústav Ústav pozemního stavitelství

Studijní obor 3608T001 Pozemní stavby

Studijní program N3607 Civil Engineering

Název práce Low energy block of apartments

Název práce v anglickém jazyce Low energy block of apartments

Typ práce Diplomová práce

Přidělovaný titul Ing.

Jazyk práce Čeština

Datový formát elektronické verze

Anotace práce Cílem práce bylo vypracování projektové dokumentace pro stavbu: Nízkoenergetický bytový dům. Dokumentace byla zpracována ve stupni pro realizaci stavby. Jedná se o čtyřpodlažní bytový dům s plochou nevětranou střechou a částečně podzemní hromadnou garáží. Stavba je navržena se zvýšenými nároky na tepelné vlastnosti objektu. Projekt dále řeší studii vytápění. Její energetická náročnost byla ověřena pomocí podrobného výpočtu dle ČSN 73 0540 a zpracovaného průkazu energetické náročnosti budovy. Výsledná energetická náročnost stavby je B – velmi úsporná.

Anotace práce v anglickém jazyce The goal of the project is development of a project documentation for a building: Low energy block of apartments. The documentation was processed in the depressed for construction realization. It solves a four floor block of apartments with flat warm roof and partially depressed parking garage. The structure is designed with risen requirements on thermal properties. The project also solves a concept of heating system. Its energy efficiency was analysed using precise calculation acc. ČSN 73 0540 and

processed statement of energy efficiency. The result energy consumption of the structure is B – very efficient.

Klíčová slova nízkoenergetický bytový dům plochá nevětraná střecha hromadná garáž studie vytápění

Klíčová slova v anglickém jazyce low energy block of apartments flat warm room parking garage heating system concept