

VYSOKÉ UČENÍ TECHNICKÉ V BRNĚ

BRNO UNIVERSITY OF TECHNOLOGY

FAKULTA ELEKTROTECHNIKY A KOMUNIKAČNÍCH TECHNOLOGIÍ
ÚSTAV ELEKTROENERGETIKY

FACULTY OF ELECTRICAL ENGINEERING AND COMMUNICATION
DEPARTMENT OF ELECTRICAL POWER ENGINEERING

TESTOVÁNÍ SVODIČŮ PŘEPĚTÍ

BAKALÁŘSKÁ PRÁCE
BACHELOR'S THESIS

AUTOR PRÁCE
AUTHOR

LUKÁŠ JEŘÁBEK

BRNO 2014

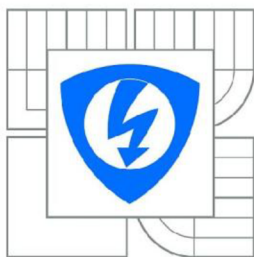

VYSOKÉ UČENÍ
TECHNICKÉ V BRNĚ

Fakulta elektrotechniky
a komunikačních technologií

Ústav elektroenergetiky

Bakalářská práce

bakalářský studijní obor
Silnoproudá elektrotechnika a elektroenergetika

Student: Lukáš Jeřábek

ID: 133269

Ročník: 3

Akademický rok: 2013/2014

NÁZEV TÉMATU:

Testování svodičů přepětí

POKYNY PRO VYPRACOVÁNÍ:

1. teorie - historický vývoj, druhy svodičů přepětí,
2. princip činnosti svodičů přepětí.
3. výrobci, uváděné parametry, vzájemné porovnání parametrů.

DOPORUČENÁ LITERATURA:

podle pokynů vedoucího práce

Termín zadání: 10.2.2014

Termín odevzdání: 30.5.2014

Vedoucí práce: Ing. Michal Krbal

Konzultanti bakalářské práce:

doc. Ing. Petr Toman, Ph.D.

Předseda oborové rady

UPOZORNĚNÍ:

Autor bakalářské práce nesmí při vytváření bakalářské práce porušit autorská práva třetích osob, zejména nesmí zasahovat nedovoleným způsobem do cizích autorských práv osobnostních a musí si být plně vědom následků porušení ustanovení § 11 a následujících autorského zákona č. 121/2000 Sb., včetně možných trestněprávních důsledků vyplývajících z ustanovení části druhé, hlavy VI. díl 4 Trestního zákoníku č.40/2009 Sb.

Bibliografická citace práce:

JEŘÁBEK, L. *Testování svodičů přepětí*. Brno: Vysoké učení technické v Brně, Fakulta elektrotechniky a komunikačních technologií, 2014, 53 s. Vedoucí bakalářské práce Ing. Michal Krbal.

Foremost, I would like to express my sincere gratitude to my advisors Mr Kari Lahti and Mr Michal Krbal for the continuous support of my research and also for their patience, motivation, and immense knowledge. Their guidance helped me in all the time of research and writing of this thesis.

Besides my advisors, I would like to thank Mr Adriano Dellalibera for his help and irreplaceable knowledge about surge arrester's manufacturers and Mr Volker Hinrichsen for providing me with his lecture notes which has been a great help for my knowledge basis.

Jako autor uvedené diplomové (bakalářské) práce dále prohlašuji, že v souvislosti s vytvořením této diplomové (bakalářské) práce jsem neporušil autorská práva třetích osob, zejména jsem nezasáhl nedovoleným způsobem do cizích autorských práv osobnostních a jsem si plně vědom následků porušení ustanovení § 11 a následujících autorského zákona č. 121/2000 Sb., včetně možných trestněprávních důsledků vyplývajících z ustanovení části druhé, hlavy VI. Díl 4 Trestního zákoníku č. 40/2009 Sb.

.....



VYSOKÉ UČENÍ TECHNICKÉ V BRNĚ

BRNO UNIVERSITY OF TECHNOLOGY

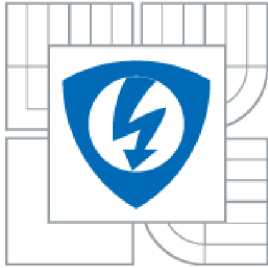

FAKULTA ELEKTROTECHNIKY A KOMUNIKAČNÍCH
TECHNOLOGIÍ
ÚSTAV ELEKTROENERGETIKY

FACULTY OF ELECTRICAL ENGINEERING AND COMMUNICATION
DEPARTMENT OF ELECTRICAL POWER ENGINEERING

TESTOVÁNÍ SVODIČŮ PŘEPĚTÍ

TESTING OF SURGE ARRESTERS

BAKALÁŘSKÁ PRÁCE

BACHELOR'S THESIS

AUTOR PRÁCE

AUTHOR

LUKÁŠ JEŘÁBEK

VEDOUCÍ PRÁCE

SUPERVISOR

ING. MICHAL KRBAL

BRNO 2014

ABSTRAKT

Tato bakalářská práce se věnuje svodičům přepětí z oxidů kovů. Po historickém a teoretickém úvodu, který vysvětluje jejich princip a popisuje jejich charakteristické vlastnosti, následuje rozebrání normy IEC 60099-4 a testování podle této normy se zaměřením na typové zkoušky. Kapitola je také doplněna o přehled nedostatků normy a její pravděpodobný budoucí vývoj. Práce je zakončena průzkumem trhu, recenzí největších producentů a srovnáním jejich produktů.

KLÍČOVÁ SLOVA: Přepětíová ochrana, postupná vlna, vysoké napětí, omezovač, svodič, elektrolytický, SiC, MO, karbid křemíku, oxid kovu, nelineární odpor, varistor, bleskosvod, historie, princip, předávání tepla okolí, plášť, výrobci, srovnání, testování, norma, recenze, trend, vývoj, IEC 60099-4, charakteristiky, třída vybití vedení, mikrostruktura, stárnutí, degradace, polymer, porcelán, tube, cage, wrapped, GIS, přenosové vedení, kabelové vedení, ponorné, Tridelta, Toshiba, Siemens, ABB, Cooper power systems, Hubbel power systems, MacLean power systems, TE connectivity.

ABSTRACT

This bachelor's thesis is devoted to metal oxide surge arresters. After historical and theoretical introduction, which explains their principles and describes their characteristic properties, analysis of the standard IEC 60099-4 and testing according to the standard with focus on the type tests follows. This chapter is also amended with review of the standard's imperfections and with its most probable future development. The work concludes with a market survey, a review of the largest manufacturers and a comparison of their products.

KEY WORDS:

Overvoltage protection, travelling wave, high voltage, surge arrester, electrolyte, SiC, MO, silicon carbide, metal oxide, nonlinear resistor, varistor, lightning rod, history, principle, energy handling capability, housing, manufacturers, comparison, testing, standard, review, trend, development, IEC 60099-4, characteristics, line discharge class, microstructure, ageing, degradation, polymer, porcelain, tube, cage, wrapped, GIS, transmission line, cable, separable, dead-front, liquid immersed, Tridelta, Toshiba, Siemens, ABB, Cooper power systems, Hubbel power systems, MacLean power systems, TE connectivity.

CONTENTS

LIST OF FIGURES	9
LIST OF TABLES	11
LIST OF SYMBOLS.....	12
1 INTRODUCTION.....	14
2 BRIEF HISTORY OF SURGE ARRESTERS	15
2.1 EARLY INVENTIONS	15
2.2 ELECTROLYTE ARRESTER	16
2.3 FIRST SILICON CARBIDE (SiC) ARRESTER	17
3 METAL OXIDE SURGE ARRESTERS (MOSA).....	20
3.1 THE DISCOVERY OF APPROPRIATE METAL OXIDE VARISTOR [2].....	20
3.2 METAL OXIDE VARISTOR MICROSTRUCTURE	22
3.3 MOSA CHARACTERISTICS	23
3.4 PROTECTION OF NETWORK EQUIPMENT BY MOSA	26
3.5 ENERGY HANDLING CAPABILITY	27
3.5.1 SINGLE IMPULSE ENERGY HANDLING CAPABILITY	27
3.5.2 THERMAL ENERGY HANDLING CAPABILITY	28
3.5.3 LINE DISCHARGE CLASS	29
3.6 AGEING AND DEGRADATION.....	30
3.7 HOUSING OF MOSA.....	31
3.7.1 PORCELAIN HOUSING AND FAILURE OF THE ARRESTER.....	31
3.7.2 POLYMER HOUSING.....	32
3.7.3 GRADING AND CORONA RING	33
3.8 SPECIAL MOSA APPLICATIONS	34
3.9 LIST OF INTERNATIONAL STANDARDS ON MOSA [1]	36
4 TESTING OF METAL OXIDE SURGE ARRESTERS	37
4.1 TESTS FOR PORCELAIN HOUSED ARRESTERS [13].....	38
4.1.1 LONG-TERM PERFORMANCE TYPE TESTS	38
4.1.2 OPERATIONAL PROPERTIES TYPE TESTS	39
4.1.3 TYPE TESTS FOR EXTERNAL PARTS OF ARRESTERS.....	40
4.1.4 INTERNAL PARTIAL DISCHARGE TYPE TESTS	43
4.1.5 ROUTINE TESTS	43
4.2 TESTS FOR OTHER ARRESTER DESIGNS [13].....	43
4.3 TRENDS IN DEVELOPMENT OF MOSA'S STANDARD TESTS	44
5 THE BIGGEST SURGE ARRESTERS PRODUCERS	46
5.1 COMPARISON.....	49

6 CONCLUSION.....	50
REFERENCES	52

LIST OF FIGURES

Fig. 1-1: The function of shielding wire [4].....	14
Fig. 2-1: Lightning Protection Then and Now on the same scale [2].....	15
Fig. 2-2: First power system arrester [2]	15
Fig. 2-3: Another early patent of lightning arrester [2]	15
Fig. 2-4: Horned Gapped Arrester [2]	16
Fig. 2-5: Electrolyte arrester ("Aluminium Cell Arrester") [2].....	16
Fig. 2-7: First Silicon Carbide Arrester Patent Filed in 1926 and Issued in 1930 [2].....	17
Fig. 2-6: Curve of Electrolytic Arrester showing significant change in resistance after the knee of the curve [2]	17
Fig. 2-8: Surge Arrester for 500 kV system by Westinghouse Electric Company appearing on the back cover of Fortune Magazine [2].....	18
Fig. 2-9: Earliest Failed Arrester Indicator by Galloway (Westinghouse) [2]	19
Fig. 3-1: Silicon Carbide Arrester on the left and MOV Arrester on the right, for 155 kV systems. 182 vs 91 kg. [2].....	20
Fig. 3-2: First Zinc Oxide Varistor Patent by Matsushita Electric Co Japan [2].....	20
Fig. 3-4: Log-log plot of the normalized $J(E)$ -characteristics of a typical ZnO varistor. (Explanatory: A - Pre-breakdown region, B - Breakdown region, C - Upturn region, 1 - DC voltage characteristic, 2 - AC voltage characteristic, 3 - Residual voltage characteristic, U_G - Continuous operating voltage (DC), U_B - Breakdown (or switching) voltage, U_v - Continuous operating voltage (AC, 50 Hz), U_p - Residual voltage, 8/20 μ s) [14].....	21
Fig. 3-3: Contrast of Surface and Grain Boundaries Barriers [2].....	21
Fig. 3-5: Polymer Housed Arrester and Porcelain Housed Arrester Comparison [2] on the left, 3 – 36 kV 5kA Polymeric Housed Metal Oxide Surge Arresters [15] on the right.....	22
Fig. 3-6: Schematic view of the "electrical" microstructure of a MO-varistor [14]	23
Fig. 3-7: Schematic representation of the magnitude of voltages and overvoltages in a high-voltage electrical power system versus duration of their appearance 1 p.u. = 2 $U_s/3$ [1].	23
Fig. 3-8: U-I-characteristic of a typical MO arrester in a solidly earthed neutral 420-kV-system [1].....	24
Fig. 3-9: Applied voltage and leakage current of the sample arrester of Fig. 3-8 when operated at phase-to-earth voltage ($U_s = 420$ kV, $U_r = 336$ kV) [1]	24
Fig. 3-10: Residual voltage of the sample arrester of Fig. 3-8 ($U_r = 336$ kV) at nominal discharge current ($I_n = 10$ kA) [1].....	25

Fig. 3-11: Simplified arrangement to illustrate the protective zone of an arrester (explanation see text) [1].....	26
Fig. 3-12: Failure mechanisms (from left) “cracking”, “flashover”, “puncture” and “flashover” in the special case of 90/200 impulse current stress [14].....	27
Fig. 3-13: Explanation of the thermal stability [1].....	28
Fig. 3-14: Specific energy dependent on the ratio of switching impulse residual voltage U_{res} to the r.m.s. value of the rated voltage U_r of the arrester (from IEC 60099-4) [1]	29
Fig. 3-15: Power loss ratio vs. time depending on the surrounding medium (air, N ₂) during accelerated ageing test at 115 °C and continuous AC voltage. [14].....	30
Fig. 3-16: Metal-oxide varistors [1].....	31
Fig. 3-17: Cross-sectional drawing of the unit of a porcelain housed MO arrester [16]	31
Fig. 3-18: Sealing system of a high-voltage porcelain housed MO arrester [14].....	32
Fig. 3-19: Cross-sectional drawing of a polymer-housed MO high-voltage arrester of "cage design" [1].....	33
Fig. 3-20: Cross-sectional drawing of a polymer-housed high-voltage arrester of "tube design" [1].....	33
Fig. 3-21: Grading ring and Corona ring [1].....	34
Fig. 3-22: 138 kV system in Brazil. [7].....	34
Fig. 3-23: Typical installation of a GIS arrester. [14]	35
Fig. 3-24: Underground Circuit with Deadfront arrester. [2]	35
Fig. 3-25: A typical under-oil metal-oxide arrester. [14].....	35
Fig. 4-1: Switching surge operating duty test on 10 000 A arrester line discharge Classes 2 and 3 and 20 000 A arresters line discharge Classes 4 and 5. [16]	40
Fig. 4-2: Test with 63 kA/0,2 s on porcelain housed arrester. [16].....	41
Fig. 4-3: Test with 20 kA/0,2 s on polymer housed distribution arrester (cage design). [16].....	41
Fig. 5-1: Tridelta [6].....	46
Fig. 5-2: TE Connectivity [7].....	46
Fig. 5-3: Maclean Power Systems [8].....	47
Fig. 5-4: Cooper Power Systems [11].....	47
Fig. 5-5: ABB [12]	47
Fig. 5-6: Siemens [10].....	47
Fig. 5-7: Hubbell Power Systems [17].....	48
Fig. 5-8: Toshiba [18].....	48

LIST OF TABLES

Tab. 3-1: Line discharge classes and associated testing parameters in [13].....29

Tab. 5-1: Product range.....49

LIST OF SYMBOLS

GE	General Electric
ABB	Asea Brown Boveri
PD Devices	Power Development Devices
TE	Tyco Electronics
NGK	Nippon Gaishi Kaisha
ESSCO	Electric Service Supply Company
USA	United States of America
IEC	International Electrotechnical Commission
IEEE	Institute of Electrical and Electronics Engineers
CIGRÉ	Conseil International des Grands Réseaux Électriques
CISPR	Comité International Spécial des Perturbations Radioélectriques
AC	Alternating Current
DC	Direct Current
HVDC	High-voltage direct current
SiC	Silicon Carbide
ZnO	Zinc Oxide
MO	Metal-Oxide
MOV	Metal Oxide Varistor
MOSA	Metal Oxide Surge Arrester
TLSA	Transmission Line Surge Arrester
GIS	Gas-Insulated Switchgear
EGLA	Externally Gapped Line Arrester
RLC circuit	Circuit consisting of resistor, inductor and capacitor.
U-I	Voltage-current
RMS	Root mean square
$U_c (U_v)$	Continuous operating voltage
U_r	Rated voltage
$U_{res} (U_P)$	Residual voltage
U_L	Charging voltage

U_g	Continuous operating voltage (DC)
U_B	Breakdown (or switching) voltage
I_{res}	Resistive component of leakage current
I_n	Nominal current
T	Virtual duration time
Z	Surge impedance of the line
J	Current density
E	Electric intensity
LIWV	Standard rated lightning impulse withstand voltage
RIV	Radio Interference Voltage
SLL	Specified Long-term Load
SSL	Specified Short-term Load
MBL	Maximum Breaking Load
S	Protective distance
s	Surge steepness
OEM	Original Equipment Manufacturer
FRP	Fiber-glass Reinforced Plastic

1 INTRODUCTION

The equipment of transmission and distribution power lines is often endangered by temporary, switching and lightning overvoltages. All equipment must be able to withstand temporary overvoltages, but we have to protect them against the two remaining. These events happen for example when the lightning strikes somewhere to the network, or when switching large inductive devices, such as electrical motor. Line-to-ground and phase-to-phase faults with other unusual conditions on the line are also responsible for overvoltages.

If we don't protect our equipment with surge arresters and shielding wires (circuit breakers will break the current flow) network components may fail in case of line overvoltage. This would cause enormous profit losses for the transmission/distribution companies, not mentioning the discomfort of consumers.

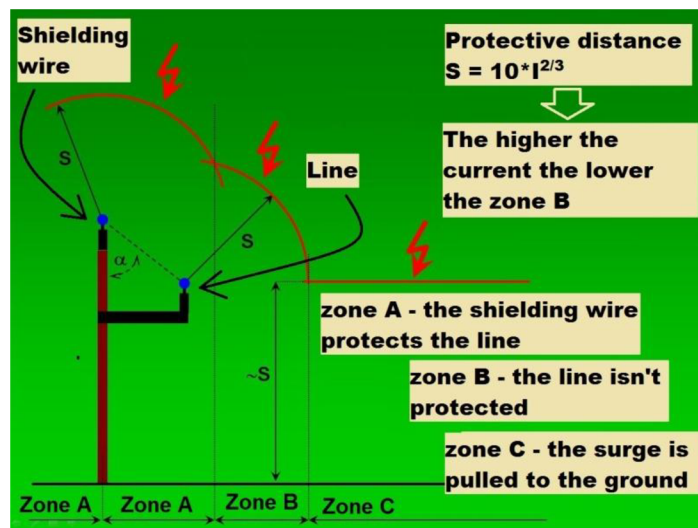

Fig. 1-1: The function of shielding wire [4]

Luckily today we already know how to protect the network from overvoltages. Lines are protected with shielding wire, which function is described in the Fig. 1-1. However shielding wires only protect equipment from direct lightnings but not from travelling waves which is arresters purpose. Until this day a huge progress has been made in the technology of surge arresters since its first invention.

All in all surge arresters are simply devices we cannot get along without and their development does not seem to end because their requirements grow while reaching higher voltages in power systems and as long as there are lightning surges a continuous research is needed.

In my work I have decided to focus on the arresters historical background starting at 1752 in chapter 2, MOSAs in chapter 3, IEC 60099-4 standard and related testing in chapter 4 and comparison of currently biggest MOSA manufacturers in chapter 5.

2 BRIEF HISTORY OF SURGE ARRESTERS

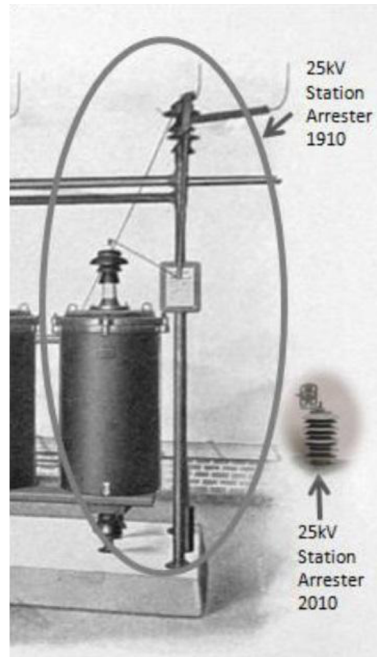

Fig. 2-1: Lightning Protection Then and Now on the same scale [2]

2.1 Early inventions

Much before an arrester was invented, Ben Franklin, the famous statesman, and Prokop Diviš invented the first arresters precursor, the lightning rod. Wikipedia says this about their invention:

“As a consequence of his research, Diviš became the inventor of the first grounded lightning rod. Benjamin Franklin had invented the lightning rod in 1752 in the United States, but it did not work well, because it was not grounded, while Diviš's apparatus in 1754 was. Therefore it worked perfectly, and was

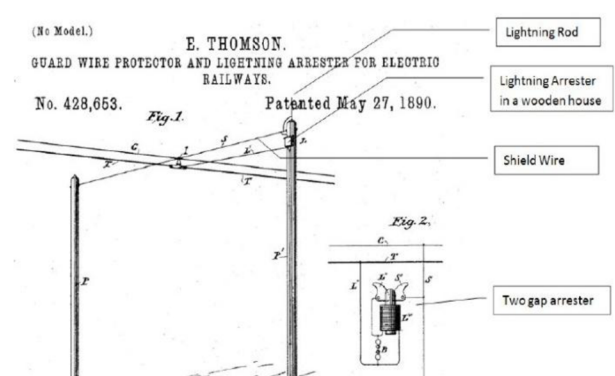

Fig. 2-2: First power system arrester [2]

constructed six years before Franklin's invention.“ [3]

(No Model.)
A. WURTS & O. H. BALDWIN.
LIGHTNING ARRESTER.
No. 433,430. Patented July 29, 1890.

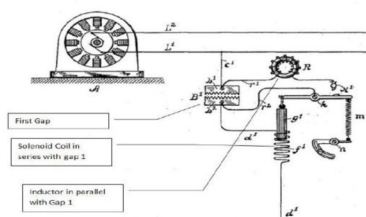

Fig. 2-3: Another early patent of lightning arrester [2]

the arc. When the voltage changed back to power voltage it was still high enough to keep the arc active and power interruption was needed after each operation. [2]

First patent to use the term “Arrester” was registered in 1860 and in 1890 Elihu Thomson patented an arrester installed on power lines for electric rails. It was a gap arrester which means that there was a gap of air between the line and the arrester through which couldn't be ignited an arc by the power voltage itself. Only lightning overvoltages were high enough to ignite the arc. Once the arc was burning through the gap it was much harder to extinguish

Few months after Thomson, Alexander Wurtz patented another kind of arrester for power system in 1890 (Fig. 2-3). His arrester had parallel inductor which is interesting because as you can see later in chapter 3.4 the inductivity of an arrester is a feature that nowadays causes problems. [2]

The engineers used only basic gap arresters which were usually installed on telegraph lines until they realised that they won't be sufficient for handling power arcs in gaps inflicted by lightning overvoltage surge. They soon learned that the only way to interrupt this arc is to turn off the AC power source or put a resistive component into the circuit. This can be accomplished for example by extending the gap while the arc flows through it or use a linear resistor in series with the gap. [2]

E. G. P. OELSCHLÄGER & K. O. F. SCHROTKE.
LIGHTNING ARRESTER.
No. 566,011. Patented Aug. 18, 1896.

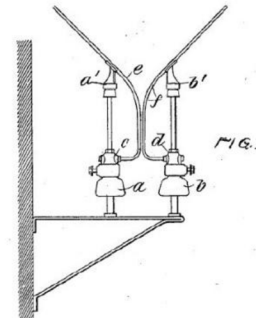

Fig. 2-4: Horned Gapped Arrester [2]

Interesting design is depicted on Fig. 2-4. Magnetic field pushes the arc towards the ends of electrodes, which make the gap and corresponding arc longer and eventually extinguishes the arc in the end. This method can sometimes still be seen today, especially in spark gaps. [2]

2.2 Electrolyte arrester

Electrolytic arrester was a great breakthrough in the field. In 1906 struggle between GE team and Westinghouse Electric team began. They both had some history behind in lightning arresters development and since there had not been many inventions for some years, they both lusted for something new. After two years work behind closed doors Elmer Ellsworth Farmer Creighton who was working for GE patented an Aluminium Cell Electrolytic Arrester which got patent in 1911. Although GE won the patent competition, Westinghouse had been selling these products on the market as well even before the patent was approbated. [2]

The voltage applied to the cell (Fig. 2-5) creates very small current through the cell as long as the critical voltage is not reached, after that the current flowing through the cell is proportionate to the excess voltage (not the total voltage applied across the arrester) divided by the resistance (which is very low) of the cell. [2]

Single aluminium cell of the electrolyte arrester is made of an electrolyte between two aluminium plates with a really thin film of aluminium hydroxide which is responsible for curve knee in U-I characteristic. At the point when the critical voltage is reached, lots of tiny punctures are created in the oxide film and as a result they allow the current to flow. On the other side, when the excess voltage is removed, all the tiny punctures disappear. This removes the need of interrupting

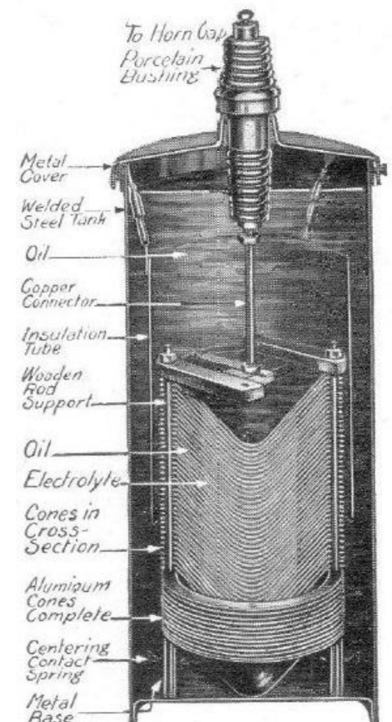

Fig. 2-5: Electrolyte arrester ("Aluminium Cell Arrester") [2]

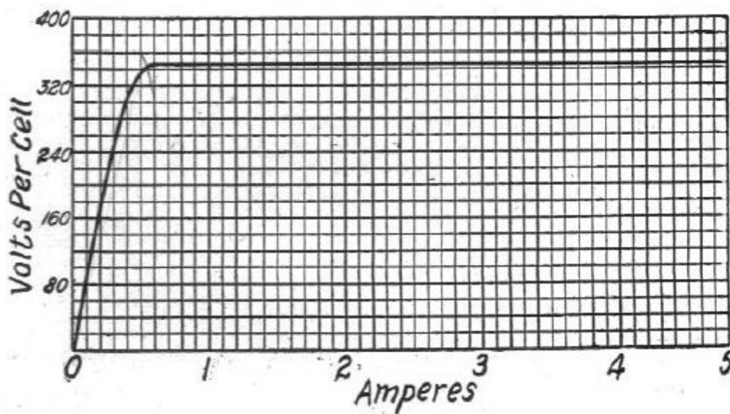

Fig. 2-6: Curve of Electrolytic Arrester showing significant change in resistance after the knee of the curve [2]

burning arc as it was before, because the power frequency current cannot flow after the tiny punctures in the oxide film disappear. Suddenly no gaps or arc breakers were needed in overvoltage protection. [2]

At the time when electrolyte arrester was being developed another company came up with Expulsion

Arrester, which basically increased the resistance of the gap by a strong airflow. Some used a method with a low ohmic resistor inserted in the

discharge circuit, which heated up the surrounding air and eventually, after it was blown out, increased the arc length and the resistance. Unfortunately this particular design could not stand higher voltages. [2]

Later on in 1915 a descendant of Electrolyte Arrester appeared. Pellet type oxide film arrester had similar U-I-characteristic but without the need of using liquid dielectric. Despite this obvious advantage it wasn't that successful as it would seem, because the oxide film got damaged during each surge, which wasn't repairable. [2]

2.3 First Silicon Carbide (SiC) arrester

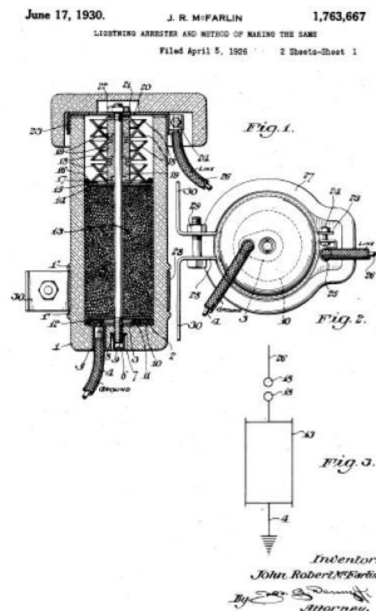

Fig. 2-7: First Silicon Carbide Arrester Patent Filed in 1926 and Issued in 1930 [2]

“In 1926 John Robert McFarlin, who was still working for ESSCO, filed for a patent (Fig. 2-7) using a new material that he referred to as: “infusible refractory materials of limited conductivity and comparatively low specific resistance in the silicon carbide family.” He goes on

to state, that “these properties greatly enhance the effectiveness, durability, stability and simplicity of surge arresters.” Thus began the long history of the Silicon Carbide (SiC) family of arresters.” [2]

Westinghouse and GE were on a battlefield for almost 20 years since their last battle over the electrolyte arrester and yet, they were not the first to come up with the SiC Arrester. Instead they developed a little bit different types (even though SiC arresters were strictly used at high voltage levels as 500 kV (Fig. 2-8)). For example Westinghouse invented the Autovalve Arrester which lasted until the 1980’s and GE engineers were even able to develop silicon carbide based material called Thyrite. These arresters were pushed out as late as the era of metal oxide arresters arrived. [2]



Fig. 2-8: Surge Arrester for 500 kV system by Westinghouse Electric Company appearing on the back cover of Fortune Magazine [2]

New era of Expulsion Arresters started since Walter G. Roman’s invention of cutout, which is a reinvented expulsion arrester. It uses material that creates a lot of de-ionized water vapor which is directed to the arc and breaks it when the voltage crosses the zero. In addition it was a long lasting device, even though it was open to the atmosphere, because all the used materials were waterproof. [2]

The next progress in arresters technologies was made in 1922 when Lawrence Rice Golladay invented a system that indicates an arresters failure. How the system works is described in the figure Fig. 2-9. After the resistor heats the wax it descends and creates a larger gap which increases the arresters withstand voltage. [2]

In 1939 Ralph H. Earle designed a brilliant idea of an arrester ground lead disconnecter. The use of an explosive charge to tear apart the ground lead is used still today. [2]

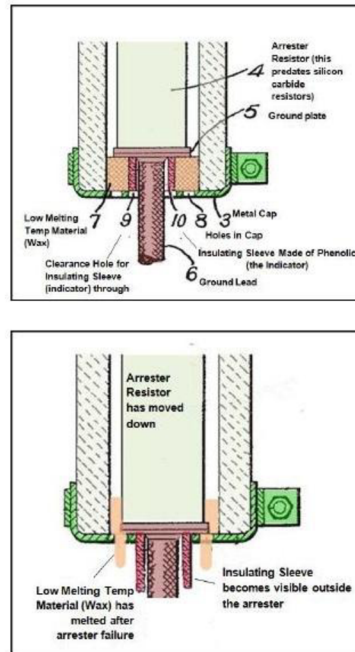

Fig. 2-9: Earliest Failed Arrester Indicator by Galloway (Westinghouse) [2]

Soon power system voltages reached 500 kV and engineers were standing in front of a problem with lightning protection of the line. Despite the fact that some of Silicon Carbide arresters with series gaps needed to be 4.5 m high to fulfil their task, in the end they came out to be the best option for this challenge. [2]

A large step in arresters innovations was made by Jack Kalb in 1957 when he reduced the total length of the arrester by circa 25% by using a concept of stretching the arc in a chamber. [2]

Nevertheless Silicon Carbide Valve arrester design basked in the glow light of fame for the whole period of 1930-1950 and later still stood firm in the market. Also all kinds of patents were derived from the 1926 McFarlin design. Nowadays these arresters are replaced with metal oxide varistors although we can sometimes see some expulsion arresters or gapped SiC arresters with glass housing on distribution system. [2]

3 METAL OXIDE SURGE ARRESTERS (MOSA)

3.1 The discovery of appropriate metal oxide varistor [2]

The urge for discovery of a new material suitable for surge arresters originates from the invention of the first transistor (1947) and the transistor radio (1948). Due to rather high protection levels, SiC arresters were simply not able to protect such overvoltage sensitive devices.



Fig. 3-1: Silicon Carbide Arrester on the left and MOV Arrester on the right, for 155 kV systems. 182 vs 91 kg. [2]

In November of 1965 young scientist Michio Matsuoka from Japan was assigned the research of a new surge protection for semiconductors. Using the knowledge of semiconductors and the results of various experiments Matsuoka decided to choose Zinc Oxide for the ceramic and Silver Oxide (with a glass frit) for the non-ohmic electrodes to merge. This was expected to create Shockley junction on the boundary of material and behave like an insulator at lower voltages and as a conductor at higher voltages. Unfortunately the threshold voltage was too low, so Matsuoka's new goal was to increase the threshold voltage so he aimed his experiments this way.

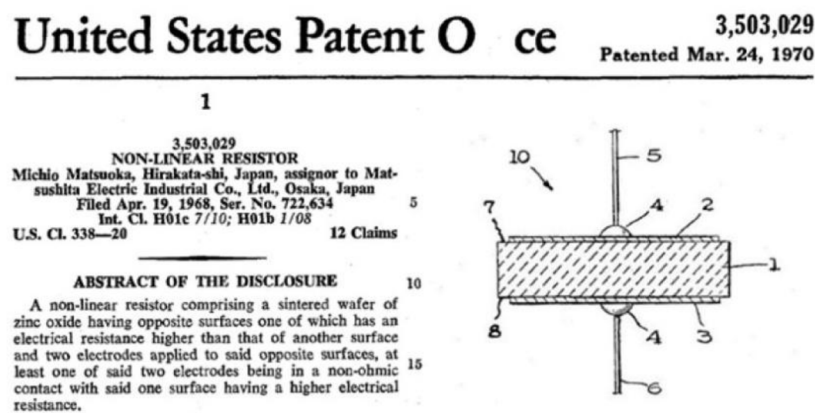

Fig. 3-2: First Zinc Oxide Varistor Patent by Matsushita Electric Co Japan [2]

Sometimes an accident is responsible for a great scientific discovery and the varistors needed for invention of Metal Oxide Surge Arrester aren't an exception. Due to a laboratory oven failure the samples were sintered at much higher temperature and the material appeared to be useless.

Luckily Dr. Matsuoka measured their characteristics anyway. Surprisingly these failed samples had the desired threshold voltage and in addition, they had no asymmetrical conductivity as all samples before.

Later scientists realised that their electrodes diffused into ZnO ceramic created plenty of Shockley junctions. This discovery is today known as the “Grain Boundary Barrier”. In this case the responsible parts were the impurities in the glass frit, for example bismuth. Dr. Matsuoka’s patent was granted in 1970 and nowadays all modern surge arresters use Zinc Oxide material with bismuth particles.

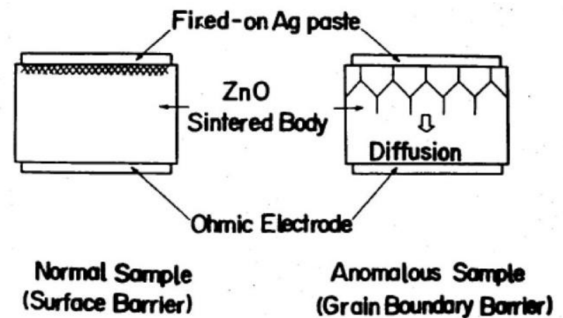

Fig. 3-3: Contrast of Surface and Grain Boundaries Barriers [2]

Meanwhile GE signed an agreement with Dr. Matsuoka to cooperate on the development of MO arresters in USA. Two years later in 1972 GE came up with the Super Alpha Varistor, which was the first GE MO varistor.

Even though this product couldn’t be installed at voltages higher than 500V it inspired the high voltage arrester design department of the GE and soon they published their first high voltage metal oxide surge arrester work which was able to operate without series gaps and that also shortened the arrester and reduced its weight. This was possible because of the extreme non-linear U-I-characteristic of the arrester which is depicted on Fig. 3-4.

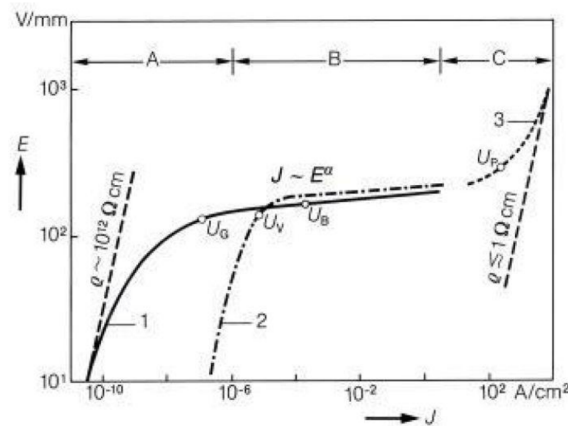

Fig. 3-4: Log-log plot of the normalized $J(E)$ -characteristics of a typical ZnO varistor. (Explanatory: A - Pre-breakdown region, B - Breakdown region, C - Upturn region, 1 - DC voltage characteristic, 2 - AC voltage characteristic, 3 - Residual voltage characteristic, U_G - Continuous operating voltage (DC), U_B - Breakdown (or switching) voltage, U_V - Continuous operating voltage (AC, 50 Hz), U_p - Residual voltage, 8/20 μ s) [14]

Suddenly all manufacturers were producing only MO varistors based on the Zinc Oxide technology. In this new industrial environment Westinghouse wasn’t able to keep up and their efforts to develop their own design that would be able to compete with the others failed.

“Latest by end of the 1980s MO arresters had definitely been established as state of the art, since their technical and commercial benefits are quite evident. MO arresters offer low protection levels, high energy absorption capabilities, and stable operation even under severe pollution conditions and lifetimes which easily may exceed thirty years.” [14]

Though GE was successful on the beginning of MOV era, by 1988 they also announced that they stop the production of arresters and remain only distributors. After 100 years of leading this industry they were replaced with other companies.

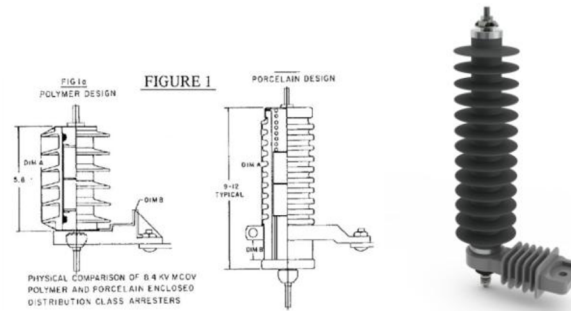

Fig. 3-5: Polymer Housed Arrester and Porcelain Housed Arrester Comparison [2] on the left, 36 kV 5kA Polymeric Housed Metal Oxide Surge Arresters [15] on the right

The year 1984 was indeed an important year for the arresters and this field once again made a great progress. Donald E. Raudabaugh utilized his knowledge and experiences gained from insulators and presented a new kind of housing for surge arresters that was much safer than earlier porcelain, because it was made of fibreglass rods covered with polymer sheds and failures were no more accompanied with explosions and blown away fragments. This modern design influenced the height and weight of the arrester as illustrated in the Fig. 3-5.

Over 150 years have passed since the first arrester invention in 1860 and recently almost only Metal Oxide Surge Arresters in polymer housing are newly installed. [2]

3.2 Metal oxide varistor microstructure

Metal oxide varistor's nonlinear characteristic is a result of its structure. As mentioned before, the main material used for these varistors is recently ZnO ceramic. It is a semiconducting material that forms of 10-20 μm grains which have really low resistivity. In contrast of highly conductive inner parts of ZnO grains there are electrostatic potential barriers in boundaries of grains which create insulating areas. Mainly these particular voltage dependant barriers are responsible for the current flow properties of a metal oxide varistor. [14]

Admixture of doping elements (for example Bi, Sb, Co,...) to the packed ZnO grains structure influences conductivity properties of the ZnO grains and the grain boundaries. Bismuth oxide and also spinel phases (which influence the grain growth and uniform distribution of its size) are separated from the grains and they are located where three adjacent grains make contact. Atomic monolayer of both bismuth and oxygen atoms can be found also at the boundaries themselves (apart from the triple points) and these are essential for the electrical function of the varistor. In a sintering process the bismuth oxide is melted and it at least partially dissolves the other substances and that way is its even spreading achieved. [14]

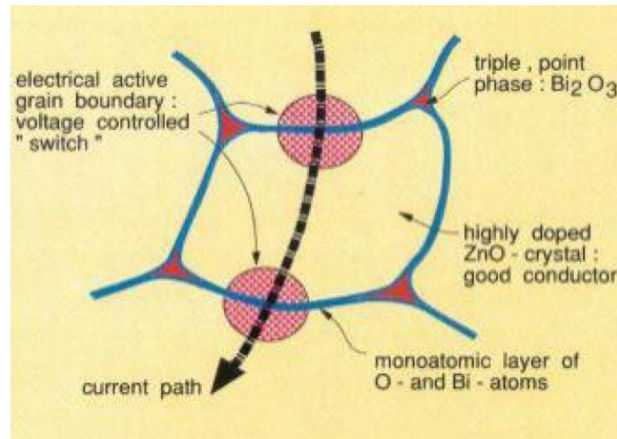

Fig. 3-6: Schematic view of the “electrical” microstructure of a MO-varistor [14]

3.3 MOSA characteristics

As mentioned before there are still many gapped arresters using silicon-carbide resistors and spark-gaps in use, but MOSAs with extremely convenient nonlinear U-I characteristic are practically the only ones that are recently installed. [1]

It is clear from Fig. 3-7 that surge arresters help to protect network equipment from lightning and switching overvoltages. This figure also represents the “insulation coordination”.

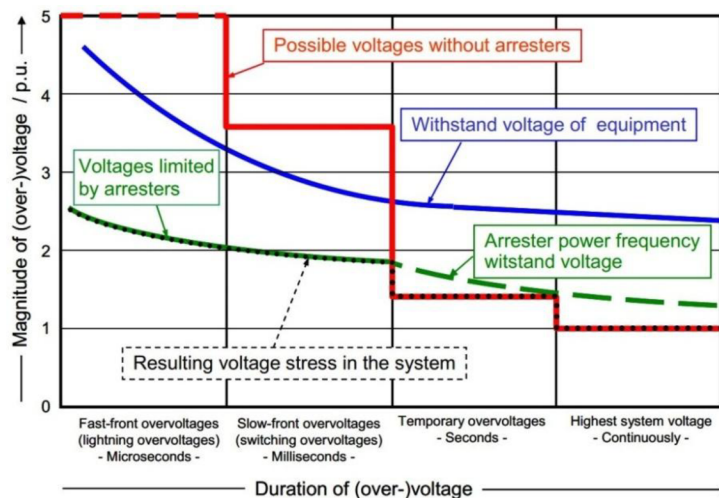

Fig. 3-7: Schematic representation of the magnitude of voltages and overvoltages in a high-voltage electrical power system versus duration of their appearance ($1 \text{ p.u.} = \sqrt{2} U_s / \sqrt{3}$) [1]

“In its simplest form, Insulation Coordination is 'The selection of insulation strength'. In a few more words, Insulation Coordination is a series of steps used to select the dielectric strength of equipment in relation to the operating voltages and transient overvoltages which can appear on the system for which the equipment is intended. Many factors are taken into account during the selection process including the service environment, insulation withstand characteristics, arrester characteristics and in some cases, the probability of potential surges.” [2]

The figure also shows that temporary overvoltages and highest system voltage doesn't damage the equipment because withstand voltage of the equipment is always higher during these conditions. However surge arrester must be also designed to withstand temporary overvoltages

and the continuous system voltage without sustaining damage. Overvoltages in Fig. 3-7 are given in per-unit of the peak value of the highest continuous phase-to-earth voltage.

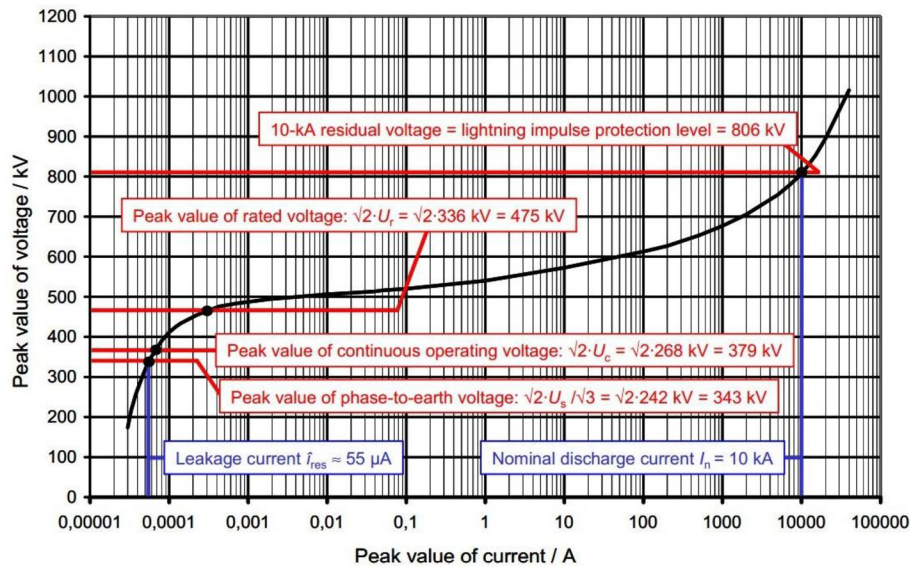

Fig. 3-8: U-I-characteristic of a typical MO arrester in a solidly earthed neutral 420-kV-system [1]

Typical U-I-characteristic of MO arrester is depicted in Fig. 3-8. MOSAs almost behave as an insulator during continuous system voltage stress and only little current passes through the arrester. There is little difference between the two lowest voltages in the depiction. While the peak value of phase-to-earth voltage is the actual voltage continuously applied to the arrester, peak value of continuous operating voltage is the voltage, which the arrester can be operated at, and is always little bit higher in solidly earth network. In other types of neutral grounding of the network the difference is much higher because there the equipment shall withstand phase-to-phase voltage as well. According to IEC 60099-5 possible harmonics must also be counted in. [16]

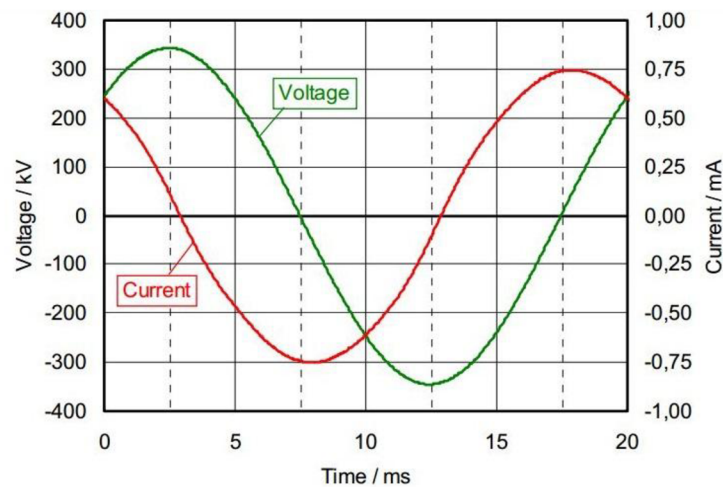

Fig. 3-9: Applied voltage and leakage current of the sample arrester of Fig. 3-8 when operated at phase-to-earth voltage ($U_s = 420$ kV, $U_r = 336$ kV) [1]

As we can see in Fig. 3-9, the leakage current has strongly capacitive character with only small resistive contribution. Therefore the leakage current value depicted in Fig. 3-8 is not exact because there is only resistive part shown. The total currents peak value is about 0.75 mA. [1]

As mentioned before, surge arrester has to withstand temporary overvoltages in the network. The next characteristic voltage, the rated voltage (U_r), shows the arresters capability of dealing with it. Depending on manufacturer these are usually allowed to last for 10-100 seconds on the arrester. Without any direct physical explanation this empirical relationship is typically:

$$U_r = 1.25 \times U_c \quad (1)$$

In addition it must be mentioned that there is more complex way of determining the rated voltage in solidly earthed neutral system. For systems of other types of neutral grounding it is this simple equation, because U_c already includes temporary overvoltages. [1]

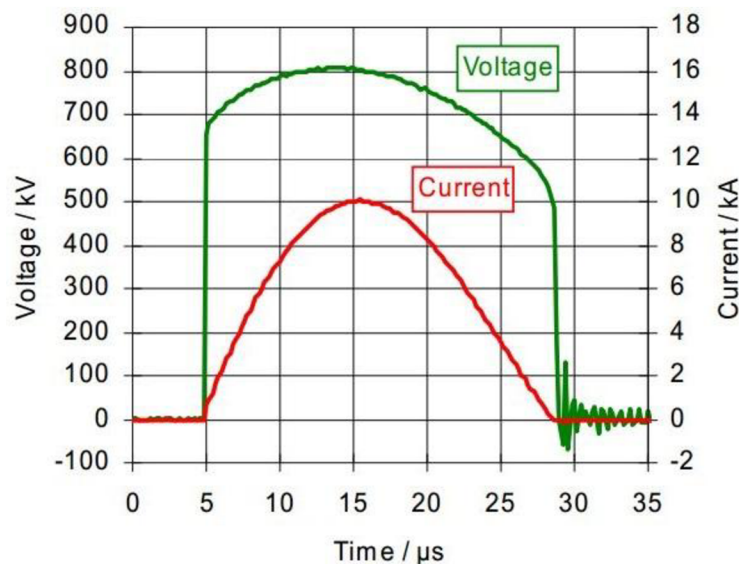

Fig. 3-10: Residual voltage of the sample arrester of Fig. 3-8 ($U_r = 336$ kV) at nominal discharge current ($I_n = 10$ kA) [1]

The last important parameter in Fig. 3-8 is the lightning impulse protective level. It is the voltage that is on the arrester when the nominal discharge current flows through the arrester. For simulation of a lightning current impulse in laboratory a current impulse 8/20 (According to IEC 60099-4), which is produced by an aperiodically damped RLC circuit as a capacitor discharge, is used. The number 8 of the current impulse describes virtual front time in microseconds, which is the time when the current reaches the peak value, and the number 20 of the current impulse describes virtual time to half-value on the tail also in microseconds, which is the time when the current reaches the half-value of the peak value after it had already been through the peak value. Although the amplitude of an impulse can be between 100A and 40kA, for high-voltage arresters ($U_s \geq 72.5$ kV) only 10 kA and 20 kA are used and for medium-voltage arresters ($U_s \geq 52$ kV) the value of 5kA is significant. The impulse quickly rises to a peak value and goes to zero (little bit slower). This is depicted in the Fig. 3-10. However the nominal discharge current tells only

little about the properties of the arrester and two arresters with the same nominal discharge current can still differ a lot in other features. [1]

3.4 Protection of network equipment by MOSA

When protecting equipment by MOSA it is also needed to take into account three circumstances in which the residual overvoltage is exceeded. Standard lightning impulse withstand voltage (LIWV) of the 420-kV-system is 1425 kV so it would seem that the arrester from the Fig. 3-8 with lightning impulse protective level of 806 kV would perfectly keep the equipment safe. However there are few exceptions in which the residual voltage can exceed LIWV:

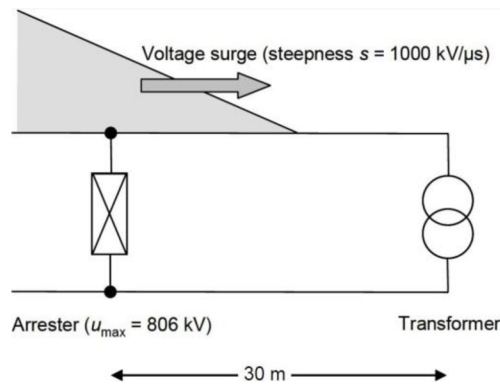

Fig. 3-11: Simplified arrangement to illustrate the protective zone of an arrester (explanation see text) [1]

- Overvoltages in the network spread in form of **travelling waves**. In this case the end of line terminated for example with a transformer (due to its high impedance in comparison with the line) leads to refractions and reflections. With conditions depicted in Fig. 3-11 reflection on the transformer superimposed with the original wave creates voltage surge with steepness of 2000 kV/μs. After this surge is formed the voltage value increases by 200 kV in each 0.1 μs which is the time that is needed to for the wave to travel 30 m. Since there can't be more than 806 kV on the arrester it stops increasing at this point. This can be achieved by that the arrester reflects a negative voltage surge of the same steepness (2000kV/μs). Despite all of this, it takes another 0.1 μs for this negative surge to reach the transformer, where the voltage has already increased of additional 200 kV resulting in final overvoltage of 1006 kV. Maximum distance from the protected equipment is called *protective zone*. [1]
- For a 10 meters long arrester with common value of inductivity which is 1 μH per meter and therefore a lightning current impulse of steepness 10kA/μs would result in

$$u = L \frac{di}{dt} = 10\mu H \times \frac{10kA}{\mu s} = 100kV (V; H, A, s). \quad (2)$$

This **inductive voltage** doesn't have to show up exactly during the peak value of the residual voltage, but it still is an important eventuality that can occur and superimpose with the arrester residual voltage. [16]

- Finally, although the arrester can withstand higher discharge currents than nominal, it results in higher residual voltage across its terminals and it may endanger the protected equipment. [1]

This all means that a special attention must be given when choosing the lightning impulse protective level of arrester. If the distances are not too big and only fast-front overvoltages can occur, the relationship between the LIWV and residual voltage of 1.4 is usually enough. It is necessary to make special calculations in cases when there are long distances in substation or very-fast-front overvoltages are expected. [1]

3.5 Energy handling capability

Apart from the electrical properties, engineers need to design the arrester with consideration of the energy development throughout the arrester.

3.5.1 Single impulse energy handling capability

It is mainly the matter of the metal-oxide resistor itself and the rest of the arrester has no effect on this attribute at all and it describes the energy handling capability of a single impulse lasting from a few microseconds to milliseconds. Ideal homogenous varistor fails only by exceeding mechanical strength of its material, while a high current is flowing through the arrester, followed by a fracture. [14]

During this event a metal oxide resistor is intensively overstressed by strong forces and imperfections of the varistor's structure cause rapid differences in temperature escalation throughout the arrester. This leads to local exceeding of single impulse overvoltage limit, which may even cause fissures or breakage of the varistor as well as just a small punctures while the varistor may still seem intact. Sometimes its electrical characteristic can change, which may later cause thermal runaway. It is even possible that invisible structure modifications pre-damage the varistor and it will not handle any more energy injection. [1] [14]

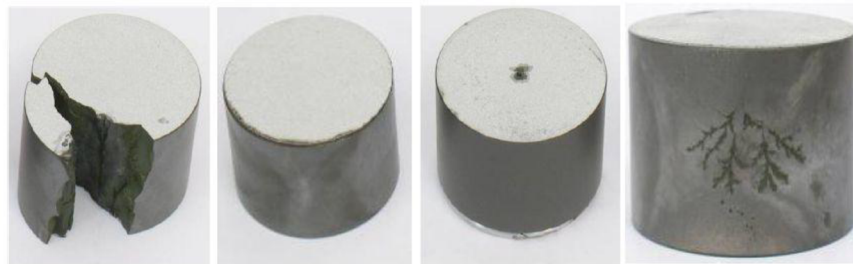

Fig. 3-12: Failure mechanisms (from left) “cracking”, “flashover”, “puncture” and “flashover” in the special case of 90/200 impulse current stress [14]

Inhomogeneities of the varistor cause current concentrations which result in local overheating. “In general, puncturing has to be expected, if the local heating is faster than the heat spreading and the ceramic locally is heated to above the melting point ($> 750-850\text{ }^{\circ}\text{C}$), where the melt can be progressively ejected, starting from the surface of the hot spot. The local heating simultaneously also creates thermo-mechanical stresses and, if these stresses reach the mechanical strength of the material before the hot spot has reached the melting point, then

mechanical fracturing can occur prior to puncturing. Alternatively cracking can follow the puncturing, if sufficient energy is deposited in the channel. Both phenomena, puncturing and cracking under long duration impulse, hence have the same origin, but the outcome will depend on such parameters as the local energy input rate, size and geometry of inhomogeneity, local stresses generated, fracture work needed etc...” [14]

It has been observed that during high current impulses (4/10 μ s) the failure mechanism is different to the long duration impulses (from few milliseconds to a second) which were introduced above. High current impulse failure is caused by the incapability of a varistor to adapt in its thermal expansion. This may also cause a fracture of a varistor block.

Finally there is only little knowledge about the flashover occurrence. [1] [14]

3.5.2 Thermal energy handling capability

This classic type of failure is depicted on Fig. 3-13. Basically it says that an arrester has to be able to release equal or more energy to the surroundings than the flowing current produces. An arrester is thermally stable if it is between the stable operating point and the thermal stability limit. Once the arrester exceeds this section it gets warmer and warmer until it self-destroys.

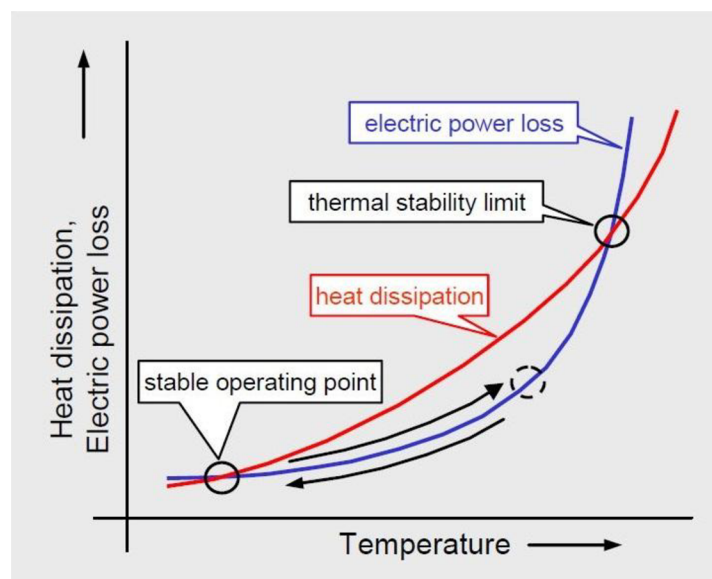

Fig. 3-13: Explanation of the thermal stability [1]

Usually the lightning overvoltage transferred over the line to the arrester is reduced by the insulators flashover voltage situated at the location of the strike and influenced by the impedance of the line. In special occasions when a nearby direct lightning strike occurs, arresters are overstressed, their energy handling capability is exceeded, and that is the cause of a common failure of the arrester. In high voltage systems a second shielding wire is installed next to the station and that is why the high voltage system arresters has much lower rate of failure from the nearby direct lightning strike. [1]

There are still some difficulties in defining the “withstand” energy capability namely whether to approach the problem deterministically or statistically, it is also possible that the type tests verifications of IEC standard ([13]) may cause arrester overdesigning, because the actual failure

probability of the arrester in praxis is close to zero, and it shall be also noted that so far it is unknown in what dependence the energy handling capability decreases with number of stresses. So far there is no standard that would give satisfying information on all the aspects of the energy handling capability. The line discharge classes concept of the IEC standard ([13]) is sufficient in standard applications [1] [14]

3.5.3 Line discharge class

The energy handling capability according to the standard ([13]) isn't described with thermal and single impulse energy handling capability. Instead only the term of "line discharge class" is used there even though it describes the energy handling capability only indirectly. It is even more important than nominal discharge current, when it comes to operating characteristics, because for example 10 kA arresters can have very different behaviour. [14]

Tab. 3-1: Line discharge classes and associated testing parameters in [13]

Line discharge class	Surge impedance of the line Z in Ω	Virtual duration of peak T in μs	Charging voltage U_L in kV (d.c.)
1	$4.9 \cdot U_r$	2000	$3.2 \cdot U_r$
2	$2.4 \cdot U_r$	2000	$3.2 \cdot U_r$
3	$1.3 \cdot U_r$	2400	$2.8 \cdot U_r$
4	$0.8 \cdot U_r$	2800	$2.6 \cdot U_r$
5	$0.5 \cdot U_r$	3200	$2.4 \cdot U_r$

U_r = rated voltage of the test sample as an r.m.s. value in kV

Line discharge class basically determines the parameters of switching overvoltage impulse in line discharge test which simulates the wave travelling process on iterative network of π -elements. Higher line discharge class arrester must withstand more unpleasant wave properties according to the Tab. 3-1. [1] [13]

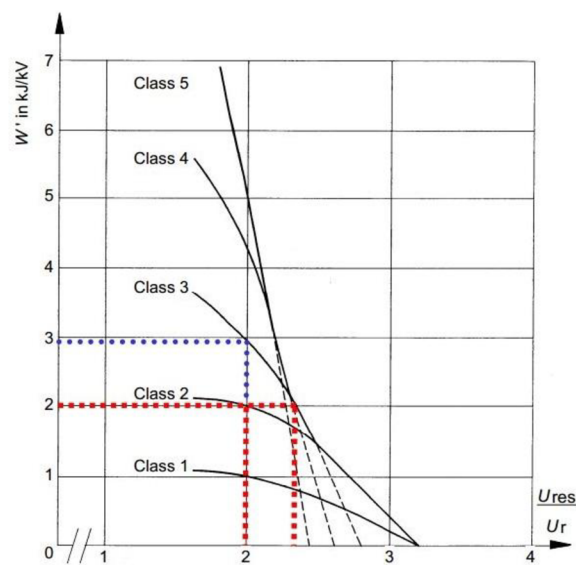

Fig. 3-14: Specific energy dependent on the ratio of switching impulse residual voltage U_{res} to the r.m.s. value of the rated voltage U_r of the arrester (from IEC 60099-4) [1]

Since this table doesn't say anything about the energy handling capability it is attached with the Fig. 3-14 in [13] which represents the specific energy (energy converted in a tested arrester divided by rated voltage of the arrester) during one single discharge in a switching surge operating duty test (chapter 4.1.2.3). So the higher is the line discharge class the more energy should be the arrester able to absorb maintaining the same residual voltage. The absorbed energy during one discharge decreases by increasing residual voltage, because then the line will discharge less intensively. [1] [14]

So for example we have an arrester that uses resistors with specific energy handling capability of 2 kJ/kV per line discharge. At the U_{res}/U_r ratio of 2 we can assign it with the line discharge class 2. If we would like to assign it with line discharge class 3, we can't just do it by raising the U_{res}/U_r ratio to 2.35 (red dotted lines in Fig. 3-14, this can be achieved by adding more varistors to the arrester, as explained in the chapter 3.7), because it may not be suitable for the planned application (it raises the residual voltage). In order to keep the same U_{res}/U_r ratio, we have to increase the specific energy to 3 kJ/kV (blue dotted lines in Fig. 3-14), which means to use a greater diameter. [1]

3.6 Ageing and degradation

Ageing significantly affects arresters by degrading its characteristics. First arresters were observed to increase their power loss during its service and became therefore thermally unstable. Power loss started increasing either immediately or after going through a power loss minimum (The Arrhenius law). This may influence the thermal stability of the arrester and this implies that the assessment of ageing is necessary. In the IEC standard ([13]) ageing is simulated by the accelerated ageing test and as seen on the Fig. 3-15 it is also influenced by surrounding medium. Test is done under the worst possible climatic conditions to ensure the long term stability of the arrester. Nowadays most of the arresters show stable power loss versus time curve in AC power systems. It is more demanding to achieve this in DC power system and higher efforts of creating DC varistor with good long term stability are made and better materials are used. [14] [13]

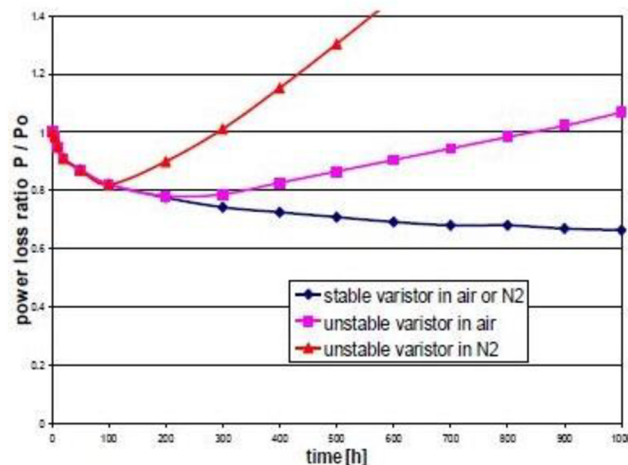

Fig. 3-15: Power loss ratio vs. time depending on the surrounding medium (air, N₂) during accelerated ageing test at 115 °C and continuous AC voltage. [14]

Today's problem is that the arresters show higher decrease of the power loss in higher temperature, which is the opposite of the behaviour expected in the standard. More research in this area is certainly needed. [14]

3.7 Housing of MOSA

The difference between the two same metal oxide varistors with various diameters is that they have different specific energy and residual voltage per millimetre of height.

For example 10 kA (of nominal discharge current) arrester is common in 420 kV. Typically varistors with diameter of 60 mm, height of 36 mm and residual voltage 360 V/mm are used there. This means that we would need 62 of these varistors in order to get the residual voltage of 806 kV (as for the arrester at Fig. 3-8). However 2.232 m ($62 \times 36 \text{ mm}$) is not the total height of the arrester. Due to creepage distance and clearance requirements of the housing the whole arrester must be much longer than the height of the varistor, even though 2.232 m could theoretically be fitted in one piece of housing, the final length of the arrester must be separated in at least two units in series for the 420 kV system. The empty spaces are filled with metallic spacers.



Fig. 3-16: Metal-oxide varistors [1]

There are two housing materials appropriate for arresters which may further distinguish by specific types. It is polymer and porcelain and the older one, porcelain (Fig. 3-17), is slowly replaced by the other. [1]

3.7.1 Porcelain housing and failure of the arrester

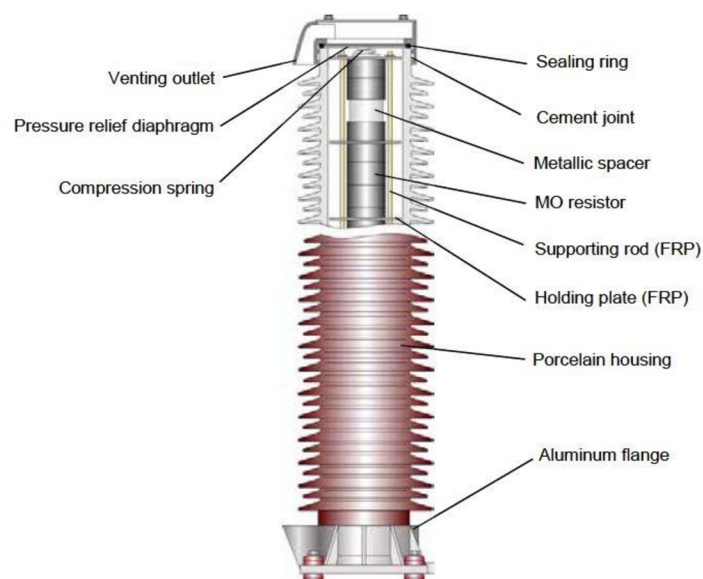

Fig. 3-17: Cross-sectional drawing of the unit of a porcelain housed MO arrester [16]

Sealing system is a part of housing that is typical for porcelain design and it is very important, also the material demands for it are really high. Users and literature agree that the most

common type of failure in arresters is inner gas leakage. Sealing system must be moisture resistant and it also has to operate as a pressure relief device which helps to deal with overload caused for example by power-frequency voltage transfer from a higher to lower voltage system (when different voltage levels cross each other) or by direct lightning strike. Without a pressure relief device the overload would cause violent shattering of the porcelain body in case of failure. What is or is not violent shattering is defined in the standard ([13]) and it is tested in the short-circuit test. The sealing system shall also provide good conductive connection from flanges to varistors. [1]

A sealing system using pressure relief diaphragm is on the Fig. 3-18. Its advantage is extremely short opening time.

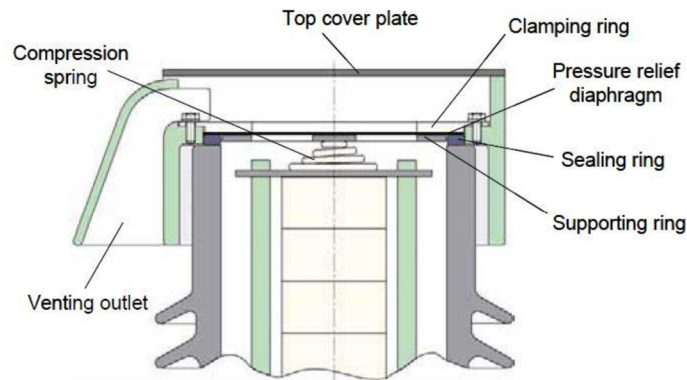

Fig. 3-18: Sealing system of a high-voltage porcelain housed MO arrester [14]

These devices are at each end of the arrester. In case of failure an arc is established inside of the housing, which increases pressure. At this point the pressure relief diaphragm quickly opens and the gas is released outside. These two streams from each end of the arrester connect and the arc is moved outside from the housing. The breakage of the arrester is still possible, but violent shattering has been prevented. [1]

3.7.2 Polymer housing

Since failures by leakage had been frequent in distribution arresters, they were slowly replaced by polymer housing designs from mid 1980's. The difference is, that the polymer arrester may have no gap (and gas) inbetween the housing and varistor blocks. Therefore the sealing system is no longer needed. [1]

Polymer housing may consist of a cage made of a fiber-glass reinforced plastic (FRP) material, which provides mechanical durability of the arrester and a silicon rubber cover with sheds, which is highly hydrophobic, cheap, light, meets dielectric requirements and has a long lifetime. Another advantage is that in case of a failure the arc simply tears up the polymer housing and no shattered pieces are thrown around the arrester, as it is with the porcelain housing. [1] [14]

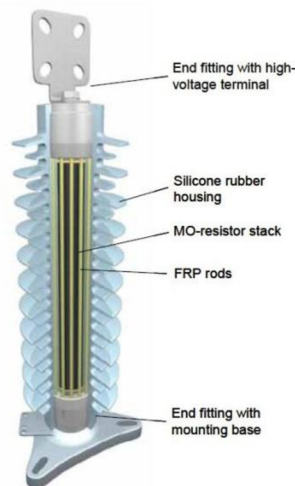

Fig. 3-19: Cross-sectional drawing of a polymer-housed MO high-voltage arrester of "cage design" [1]

Although this “cage” housing is also used at higher voltage levels, it is very hard to comply with the criteria for high mechanical strength. For these applications an arrester with polymer housing that uses composite hollow core insulator is the right choice. It is also called “tube design”. This design is very similar to ordinary porcelain arrester, but the difference is that the housing is made of an FRP tube with sheds of silicon rubber directly molded on the tube. This design is gifted with enormously flexible mechanical property. [16] [1]

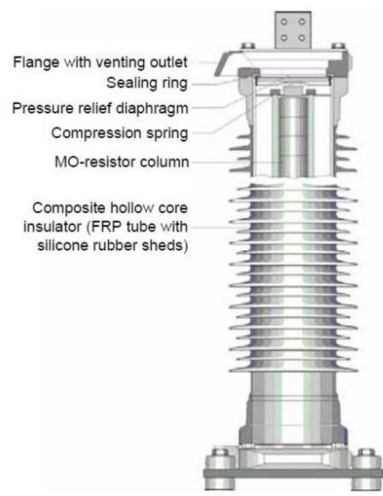

Fig. 3-20: Cross-sectional drawing of a polymer-housed high-voltage arrester of "tube design" [1]

Polymer housings are really prospective to the future. Although the investment costs are higher, the technology advantages slowly allure more and more interest. There are almost only polymer housing in the medium voltage systems and soon it will probably be the same at high voltages. [1] [14]

3.7.3 Grading and corona ring

For an arrester composed of several units or from 1.5 m – 2 m height, it is necessary to have a grading ring. During application of operating voltage on the arrester’s terminals the capacity to

the ground from the point above a varistor and from the point under the varistor differs. Higher distance to the ground causes lower capacity, therefore higher voltage. The grading ring balances this uneven distribution. Otherwise the high voltage end would be overstressed and cause overheating. The bigger the grading ring size the better the balance effect, but on the other side it can't be too long, because minimum distances requirements must be met and there would also be the danger of flashovers. [1]

For extra high voltage systems the corona ring, which reduces the radio interference voltage (RIV), is also needed. Corona occurs on sharp edges of the device and it causes the RIV. [1] [16]

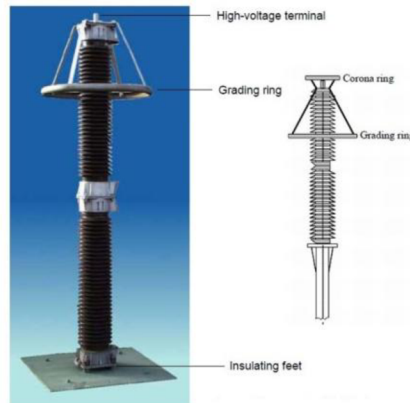

Fig. 3-21: Grading ring and Corona ring [1]

3.8 Special MOSA applications

Special MOSA applications include transmission line surge arresters (TLSA), gas-insulated metal enclosed arresters (GIS-arresters), separable and dead-front arresters and liquid-immersed arresters.



Fig. 3-22: 138 kV system in Brazil. [7]

Transmission line surge arresters can be used to limit voltages between the phase line and the tower structure to prevent insulation flashover (back flashovers and badly shielded lines as well) and therefore there is no longer the arc extinguishing problem which means that overcurrent protection does not have to react. [2] [13]



Fig. 3-23: Typical installation of a GIS arrester. [14]

GIS-arresters are mentioned in the IEC standard and this is its definition: “Gas-insulated metal-enclosed metal-oxide surge arrester without any integrated series or parallel spark gaps, filled with gas other than air.” [13] The purpose of GIS-arresters is to provide substations with as compact arrester as possible. To achieve this gas with higher insulating properties than air is needed. Commonly SF₆ which meets this criterion is used. [2] [13] [14]



Fig. 3-24: Underground Circuit with Deadfront arrester. [2]

Separable and dead-front arresters are quite similar to each other. They are typically used for cable connections to protect the ground-mounted or underground transformer. The difference is that separable arresters are more common in Europe and they are dead-break arresters, while dead-front are more common in America and they are load-break arresters. Dead-front arrester is always screened. [2] [13] [14]



Fig. 3-25: A typical under-oil metal-oxide arrester. [14]

Liquid-immersed arresters also known as under-oil arresters are typically located inside the tank of transformer. “Further advantages are correction of capacitive effects, a space saving assembly, factory testing of complete system, reduction of on-site assembly cost and increased personal safety. However, there are other benefits worth mentioning. In particular the influence of environmental conditions typically afflicting outdoor arresters is absent. There is also usually no outdoor-type housing, which removes a performance-influencing variable.” [14] Problems that may occur with this arrester type are retention during fault currents, potentially corrosive nature of its fluid, testing and failing detection. [2] [13] [14]

3.9 List of international standards on MOSA [1]

a) IEC standards on surge arresters

IEC 60099-4	Surge arresters – Part 4: Metal-oxide surge arresters without gaps for a.c. systems.
IEC 60099-5	Surge arresters – Part 5: Selection and application recommendations
IEC 60099-8	Surge arresters – Part 8: Metal-oxide surge arresters with external series gap (EGLA) for overhead transmission and distribution lines of a.c. systems above 1 kV

b) IEC standards on insulation coordination

IEC 60071-1	Insulation co-ordination – Part 1: Definitions, principles and rules
IEC 60071-2	Insulation co-ordination – Part 2: Application guide
IEC TR 60071-4	Insulation co-ordination – Part 4: Computational guide to insulation co-ordination & modelling of electrical networks
IEC TS 60071-5	Insulation co-ordination – Part 5: Procedures for high-voltage direct current (HVDC) converter stations

c) Other international and national standards, also relevant for arresters

IEC 60060-1	High-voltage test techniques. Part 1: General definitions and test requirements
IEC 60507	Artificial pollution tests on high-voltage insulators to be used in a.c. systems

IEC 60672-3	Ceramic and glass-insulating materials – Part 3: Specifications for individual materials
IEC 60694	Common specifications for high-voltage switchgear and control standards
IEC/TS 60815-1	Selection and dimensioning of high-voltage insulators intended for use in polluted conditions - Part 1: Definitions, information and general principles
IEC/TS 60815-2	Selection and dimensioning of high-voltage insulators intended for use in polluted conditions - Part 2: Ceramic and glass insulators for a.c. systems
IEC/TS 60815-3	Selection and dimensioning of high-voltage insulators intended for use in polluted conditions - Part 3: Polymer insulators for a.c. systems
HD 637 S1:1999	Power installations exceeding AC 1 kV
IEC 61936-1	Power installations exceeding 1 kV a.c. – Part 1: Common rules
IEC 62073	Guidance on the measurement of wettability of insulator surfaces
d) American arrester standards	
IEEE C62.11-2005	IEEE Standard for Metal-Oxide Surge Arrester for AC Power Circuits (>1 kV)
IEEE Std. C62.22-2009	IEEE Guide for the Application of Metal-Oxide Surge Arresters for Alternating-Current Systems

4 TESTING OF METAL OXIDE SURGE ARRESTERS

The most important standard on MOSA is IEC 60099-4. ([13]). There are also some other indispensable standards needed for its application and they are mentioned at its beginning.

In the standard ([13]), there are several important current waveforms specified.

- *Steep current impulse*: “Current impulse with a virtual front time of 1 μs with limits in the adjustment of equipment such that the measured values are from 0.9 μs to 1.1 μs and the virtual time to half-value on the tail is not longer than 20 μs .”

- *Lightning current impulse*: “8/20 current impulse with limits on the adjustment of equipment such that the measured values are from 7 μ s to 9 μ s for the virtual front time and from 18 μ s to 22 μ s for the time to half-value on the tail.”
- *Long-duration current impulse*: “Rectangular impulse which rises rapidly to maximum value, remains substantially constant for a specified period and then falls rapidly to zero”
- *High current impulse of an arrester*: “Peak value of discharge current having a 4/10 impulse shape which is used to test the stability of the arrester on direct lightning strikes”
- *Switching current impulse of an arrester*: “Peak value of discharge current having a virtual front time greater than 30 μ s but less than 100 μ s and a virtual time to half-value on the tail of roughly twice the virtual front time.”

4.1 Tests for porcelain housed arresters [13]

Every test in this chapter is designated for all the arresters with some exceptions or modifications (also mentioned in chapter 4.2.) for polymer-housed, GIS, separable/dead-front and liquid-immersed arresters which are specified later in the standard

Probably the most important part of this standard is the type tests chapter. These type tests shall be carried out on every new completed arrester design after its development. Producers don't always have to perform every single test but there is a table that shows which type tests are necessary according to the nominal discharge current of the arrester.

4.1.1 Long-term performance type tests

4.1.1.1 Environmental tests

This test ensures that the uncovered metal parts and the sealing mechanism are not disrupted by the environmental conditions. After sample preparation, testing starts with the Temperature cycling test, during which the temperature changes from almost -50 °C to 70 °C, followed by Salt mist test (all according to IEC 60068-2).

4.1.1.2 Seal leak rate test

This test proves gastightness and watertightness of the complete arrester. Manufacturer has a free hand here and may use any method suitable for the measurement of the seal leak rate, for example according to IEC 60068-2-17.

4.1.1.3 Accelerated ageing procedure

When the arrester is used for a certain period of time, its characteristics change and the purpose of the accelerated ageing test is to obtain voltages that allow performing the operating duty type test on a new varistor as it was an aged one. This is possible, because these voltages represent the same power losses as an aged varistor. The accelerated ageing procedure is performed on a sample preheated to 115 °C and the corrected maximum continuous operating

voltage (derived from voltage distribution measurements or computations) is applied there for as long as 1000 hours.

4.1.2 Operational properties type tests

4.1.2.1 Residual voltage tests

Residual voltage tests consist of steep current impulse residual voltage test, lightning impulse residual voltage test and switching impulse residual voltage test, where the first mentioned must be corrected for inductive effects of the measuring circuit and for the geometry of the test sample and the circuit.

Depending on the manufacturers choice of routine test procedure the voltage level there can be either the reference voltage or the residual voltage at suitable lightning impulse current specified in the standard. The reference voltage is a voltage measured at the reference current, which is a peak of the resistive component of a power-frequency current. In practise, the voltage has to be high enough so that the capacitive currents will not affect it. This voltage is used in some tests because such a value is highly sensitive to arrester properties. The final value is also affected by nominal discharge current and/or line discharge class of the arrester. The voltage level used in routine test shall be specified by manufacturer.

Residual voltage tests' purpose is to collect the data to calculate the ratio between voltages at specified impulse currents and the voltage level used in routine tests. In practise manufacturers publish directly the voltages at specified impulse currents instead of the ratios.

4.1.2.2 Long-duration current impulse withstand test

There are a bit different impulse requirements for the 5/2,5 kA arresters and the 10/20 kA arresters, where the latter are tested as a line discharge test according to the Tab. 3-1 with some more details, while the 5000/2500 A arresters have their own little bit simpler requirements.

The residual voltage tests shall be made again after this test when the samples are about ambient temperature. New values shall not change by more than 5%.

4.1.2.3 Operating duty tests

In service conditions there is a lot of strain put on the arrester. These stresses shall not inflict thermal runaway or any damage. With the long-duration current impulse withstand test it is the most important type test because it determines that the arrester is able to withstand these stresses for its lifetime.

This is the tests procedure:

- Initial measurements
- Conditioning
- Application of impulses
- Measurements and examination

Initial measurements consist of accelerated ageing procedure and examination of heat dissipation behaviour because the performance of a sample in operating duty test is highly dependent on heat dissipation (its ability to cool down between impulses) and the test sample shall have a transient as well as steady-state heat dissipation capability. As for the examination, there are requirements for the thermal model in the standard. The thermal model shall then represent the arrester with thermal equivalence.

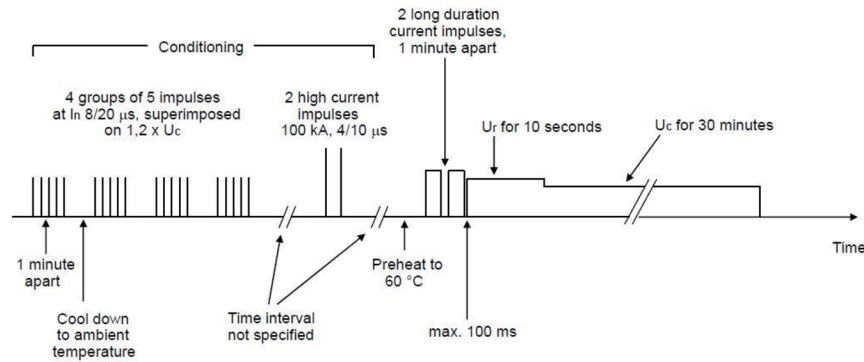

Fig. 4-1: Switching surge operating duty test on 10 000 A arrester line discharge Classes 2 and 3 and 20 000 A arresters line discharge Classes 4 and 5. [16]

The rest of the procedure depends on the arrester type. There are two kinds of tests. The first one, high current impulse operating duty test, is performed on 1500 A, 2500 A, 5000 A, 10 000 A (only line discharge class 1) and high lightning duty arresters. The second one, switching surge operating duty test, is performed on 10 000 A (line discharge classes 2 and 3) and 20 000 A (line discharge classes 4 and 5). An example of the latter is on the Fig. 4-1.

After operating duty test the residual voltage test shall be repeated. “The arrester has passed the test if thermal stability is achieved, if the change in residual voltage measured before and after the test is not more than 5 %, and if examination of the test samples after the test reveals no evidence of puncture, flashover or cracking of the linear metal/oxide resistors.” [13]

4.1.3 Type tests for external parts of arresters

4.1.3.1 Insulation withstand tests on the arrester housing

The test indicates the arresters housing capability (its dielectric stability) to withstand lightning impulse, switching impulse and power-frequency voltages under specified ambient air conditions. This is done by number of consecutive impulses. The unit housing that has the highest specific voltage stress is chosen for this test. There is also the wet test in the procedure and as well as all the tests mentioned before it shall be done according to IEC 60060-1.

Evaluation of these tests is based on the number of occurring internal and external disruptive discharges.

4.1.3.2 Short-circuit tests

This test proves, that an arrester won't shatter violently in case of short-circuit current claimed by the manufacture. Any appliance that the arrester is supplied with instead of an ordinary pressure relief device shall be subjected to the test with the arrester.

There is a different procedure for arresters "design A" and "design B".

"Design A" is filled with a gas and it fills $\geq 50\%$ of the volume inside the arrester (without the inner active parts). Commonly, "Design A" are porcelain or polymer arresters, which housings have a hollow inside and they are provided with pressure-relief devices or weak spots, that breaks at a stipulated pressure.

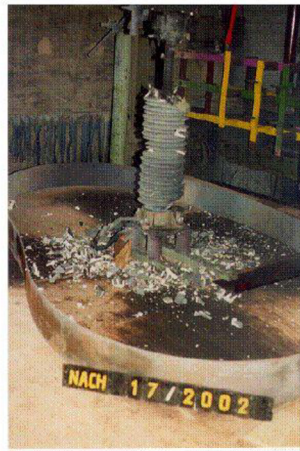

Fig. 4-2: Test with 63 kA/0,2 s on porcelain housed arrester. [16]

While "Design B" is not filled with gas or it has $< 50\%$ of the inner volume (without inner active parts) filled with gas. "Design B" arresters are commonly porcelain or polymer arresters, which don't have any pressure relief device and they are solid with no gas. These arresters set up an arc in case of a failure. This arc causes shattering of the housing and it succeeds the test when the shattering isn't too violent (according to the standard).



Fig. 4-3: Test with 20 kA/0,2 s on polymer housed distribution arrester (cage design). [16]

The test consists of high-current short-circuit test (at full voltage or in case of insufficient laboratory equipment there is an alternative procedure that uses less than 77 % of rated voltage) and low current short-circuit test. Those are preceded by the preparation and mounting of the test samples and followed by evaluation of test results. Shattered pieces are not allowed to be found

outside a specified area (there are some exceptions) and it shall self-extinguish any occurring fire in a period of time defined in the standard.

4.1.3.3 Test of the bending moment

This test only checks the bending moment. It can be applied to surge arresters which can be distinguished by the line discharge class and that are base-mounted. The standard defines these terms:

- *Specified long-term load (SLL)*: “Force perpendicular to the longitudinal axis of an arrester, allowed to be continuously applied during service without causing any mechanical damage to the arrester.” [13]
- *Specified short-term load (SSL)*: “Greatest force perpendicular to the longitudinal axis of an arrester, allowed to be applied during service for short periods and for relatively rare events (for example, short-circuit current loads and extreme wind gusts) without causing any mechanical damage to the arrester.” [13]
- *Mean breaking load (MBL)*: “The average breaking load for porcelain or cast resin-housed arresters determined from tests” [13]

Once the arrester is mounted to the testing machine the sample preparation, test procedure and the test evaluation follows. Test procedure consists of a test to derive mean value of breaking load (MBL) and a test to verify the specified short-term load (SSL). The arrester passes the test when the MBL value is 1.2 times higher than SSL value and remaining deflection is in the limits. It is also good to note, that the SLL value is only 40 % of the SSL value.

User may also specifically demand the seismic tests in the agreement, which shall be performed according to IEC 61166.

4.1.3.4 Radio interference voltage (RIV) test

This test evaluates the electromagnetic compatibility of the arrester and it is only for the open-air arresters with a rated voltage of 77 kV or more and it ensures that the radio interference background level is at preferably 10 dB (at least 6 dB) below the specific radio interference level of the arrester. The measuring circuit shall meet the CISPR 16-2 requirements (Special Committee on Radio Interference), the arrester shall be completed (including all the standard equipment) and then it shall be subjected to the test voltage. The arrester passes the test if the radio interference voltage does not exceed 2500 μV .

4.1.3.5 Tests of arrester disconnectors/fault indicators

Arresters with either a disconnector or fault indicator shall be subjected to these tests.

Long-duration current impulse test and operating duty test shall be performed on the arrester and built-in disconnector/fault indicator at the same time. It may be performed on the arrester and disconnector/fault indicator separately or at the same time, when it is designed for attachment. The disconnector/fault indicator shall not operate in any of these tests.

There is also time versus current curve test for disconnectors which obtain time versus current curves.

4.1.4 Internal partial discharge type tests

Unit housing that has the highest specific voltage stress shall be subjected to this test and the samples shall be shielded so that no external partial discharges occur. Measurement is carried out according to IEC 60270 and the value for internal partial discharge shall not exceed 10 pC.

4.1.5 Routine tests

Routine tests are made on every manufactured arrester. It consists of reference voltage measurement, residual voltage test, internal partial discharge test, leakage check (these are already mentioned in type tests) and current distribution test for multi-column arrester (in parallel), which has not been mentioned before and where the highest measured current shall stay in the limits.

There is also standard acceptance test which little bit modifies the routine tests and special thermal stability test which consists of some parts of operating duty test. Both of these are not necessary and have to be specifically required in purchase agreement to be performed.

4.2 Tests for other arrester designs [13]

Although some parts of the tests are the same as for the porcelain-housed arrester, many tests for other designs are little bit modified.

For a polymer-housed arrester the most important modification comes with the test of the bending moment. The arrester is subjected to both SLL and SSL and proves its ability to withstand them. There is no MBL defined for the polymer-housed arrester. There is also a water immersion test to check the tightness of polymer housed MOSAs where an arrester is immersed in a vessel in boiling deionized water with a specific amount of dissolved NaCl for 42 hours which is preceded by mechanical/thermal conditioning.

Also there is another test called weather ageing test during which a specific environmental conditions are applied for a certain amount of time to prove the polymers weather ageing resistance. When severe conditions are expected for the arrester to operate in there is also possible variation to perform a longer and more demanding version of the test. However, also some other concrete procedures are little bit modified for this housing.

For GIS-arresters, several type tests do not apply here because they are not necessary from the nature of GIS-arresters, which are not subjected to any environmental stresses (environmental test, bending moment test...). Operating duty tests procedures are modified and insulation withstand tests shall be performed differently mostly because the voltage stresses between internal parts and metal housings (also between phases for a three-phase arrester) shall be checked to meet the requirements.

Separable and dead-front arresters have some modifications in chapter of insulation withstand tests on the arrester housing, where the procedure depends on whether the arrester is screened or not. Internal partial discharge test is also modified. Separable, dead-front and liquid-immersed arresters have also the short circuit test and insulation withstand tests on the arrester housing little bit modified.

4.3 Trends in development of MOSA's standard tests

“Founded in 1921, CIGRE, the Council on Large Electric Systems, is an international non-profit Association for promoting collaboration with experts from all around the world by sharing knowledge and joining forces to improve electric power systems of today and tomorrow.” [21]

Cigre's working group A3.17 whose designation is „Evaluation of stresses of surge arresters and appropriate test procedures” released two critical reviews ([19], [20]) on the older IEC standard (edition 2.1) in 2007. Although a newer standard has already been released, only few things have been changed and changing it all takes some time as well as acceptance from all relevant parties. The critical review still applies for the most of the standard.

The hot topic of discussions about the standard is the energy handling capability. Although it is often requested characteristic of the arrester from users, it is not exactly specified in the standard and in fact there is no mention about it at all. It is complicated to understand the line discharge classes relation to energy handling capability and it has evolved this way historically during development of arresters. As explained in the chapter 3.5, line discharge class is used instead of determining the single impulse energy handling capability (reaction of varistor to a single sudden fast impulse) and thermal energy handling capability directly (its ability to avoid thermal runaway). [19] [20]

However the switching surge operating duty test, which tests the arrester whether it is able to cool back to ambient temperature after energy injection under continuous operating voltage, can be considered as a thermal stability test. In addition the long-duration current impulse withstand test gives some information on the resistors durability, but it would have to be performed on higher energy levels to be useful. This is not sufficient description of energy handling capability for special arresters application (line arresters,...), even though it could be sufficient for normal applications. [19] [20]

This is why most of manufacturers publish a long-duration current withstand capability, which is usually based on long-duration current impulse withstand test with a fixed time duration of the impulse and fixed maximum permitted current. In contrast to the line discharge class, where the varistor can be assigned even to three line discharge classes (depending on the residual voltage), such value describes the behaviour of a single varistor of specific diameter and quality. This is of course easier to compare. The problem is that this isn't specified in the standard and determining the impulses parameters and applied procedure can differ among the manufacturers. [19]

There are also other topics of the standard that are discussed. For example pre-conditioning in operating duty test is considered to be meaningless for today's MOSAs and it's presence in the standard is considered only as a historical remain from SiC arresters. Another point is that 10-kA surge arrester of line discharge class 1 should be tested with switching surge operating duty test, not with high current impulse operating duty test. [19] [20]

These works critically review the standard and thoroughly points out even more parts that needs improvement or more observation. Sometimes authors themselves propose new procedures.

Another problematic areas are for example the ageing test of operating duty test, annex D (Procedure to verify the power-frequency voltage-versus-time characteristics of an arrester), insulation withstand tests for multi-unit arresters and many more. In addition, sometimes the standard sets requirements without giving any specific procedure to obtain such data (for example specifying torque and tensile loads). This of course needs to be clarified in the future. [19] [20]

5 THE BIGGEST SURGE ARRESTERS PRODUCERS

Today, surge arrester manufactures can be found all over the world. Important thing for the manufactures is to produce good varistors or at least to have a good supplier. Some of the ZnO varistor manufactures are Austrian Epcos, which has moved to China where it operates as Siemens' supplier, English PD Devices and Indian Crompton Greaves. Although there are giant manufactures as ABB, Siemens, TE,... there are also many smaller producers often with local appliance which I am not able to include all in my thesis. There is for example Brazilian Balestro, which is the biggest arrester company in the south hemisphere and which also has some businesses in other continents, Spanish Inael, which also researches nanomaterials, Japanese NGK, which focuses on line arresters, Surgetek from South Africa, which actually distributes Tridelta's arresters, hundreds of Chinese manufactures, which so far does not have acceptable quality, and many more. [23]

Therefore I have decided to focus only on large world-wide known manufacturers of surge arresters and their station high-voltage arresters for the comparison in chapter 5.1. I have chosen these manufactures:

- Tridelta
- TE Connectivity
- MacLean Power Systems
- Cooper Power Systems
- ABB
- Siemens
- Hubbel power systems
- Toshiba

Tridelta is a German company, which has recently acquired French Areva arresters division, has been established more than 100 years before and their catalogues involve surge arresters since 1960. Today Tridelta provides a wide scale of station surge arresters ranging from 1000 V to 800 kV systems, transmission line and DC/medium/high voltage applications and accessories in 80 countries used also in extreme conditions. They have also their own high-voltage laboratory and manufacture their own metal oxide varistors. Their arresters reach every continents countries (Brazil, Iran, Saudi Arabia, South Africa, Australia,...). [6]



Fig. 5-1: Tridelta [6]



Fig. 5-2: TE Connectivity [7]

TE Connectivity is a huge corporation which provides employment for over 90 000 people and which offers a wide range of power energy products. Their headquarters are located in Switzerland and Tyco is the division of TE that manufactures arresters. Large system voltage scale of the arresters is amended by transmission line

arresters, medium, low and DC voltage arresters and monitoring systems. TE also manufactures some indoor and other special arrester applications. Their services can be used in more than 50 countries. [7]

MacLean Power Systems is American company. It is a part of MacLean-Fogg which is a global enterprise which arches over MacLean-Fogg Component Solutions and MacLean Power Systems. The second one focuses on products for electric utility such as transmission lines, distribution lines, substations and also telecommunications and civil markets. Among arresters their production includes high-voltage station arresters as well as distribution and transmission line arresters also with accessories. They operate at many world markets such as USA, Canada, China and also in Latin America, the Middle East, Asia Pacific, Africa and Europe. [8]



MACLEAN POWER SYSTEMS

Fig. 5-3: Maclean Power Systems [8]



Fig. 5-4: Cooper Power Systems [11]

Cooper Power Systems is also from USA and its history is connected to Thomas A. Edison through company McGraw-Edison, which is one of Edison's original companies. It became part of Cooper Power Systems in 1985 and the whole concern, which connects much more companies now, employees 100 000 people and each division plays a key role in their business. They are able to provide devices which transform, protect, connect or build out almost anything considered power voltage production. Considering surge arresters, there are dead-front/separable, low, medium and high voltage, under-oil, distribution and transmission line arresters with accessories available on the internet. In 2011 Cooper power systems operated in 23 countries. [11]

ABB's headquarters are settled in Zurich, Stockholm and New York and this power energy giant is well known world-wide for its high quality products and leading technology. ABB employees 150 000 people and its history extends to 120 years back in the past. Their surge arresters range from medium to high voltage levels supported by selection of accessories and protection for GIS substations as well. They also produce transmission line arresters and their own varistors. Together with Siemens their extra guides and free documents as well as videos, which are available on the internet, are prepared very neatly with large content and it is a great help to the customers. It operates in approximately 100 countries. [12]



Fig. 5-5: ABB [12]



Fig. 5-6: Siemens [10]

Siemens, which is a German company, may not need any introduction as well as ABB, because it has been in the business for over 165 years. It employees

367 000 people and its wide range of products speak for itself. “We’re the only manufacturer worldwide with know-how, products, solutions and key components spanning the entire energy conversion chain.” [10] Types of arresters that Siemens produces are high, medium, low and DC voltage arresters as well as GIS substations and transmissions line arresters. Accessories can also be found on their website. Siemens operates almost in the whole world. Nowadays their prices are said to be unbeatable because of their plant in China. [10]

Hubbell Power Systems with its headquarters in USA is a company which have a rich history that starts at 1888 when Harvey Hubbell began to manufacture his products. Hubbell power systems incorporate many companies related to power, electricity, lightning. They also manufacture OEM and telecommunication products. For arresters, it is the Ohio Brass company, which also produce insulators. They offer distribution, substation and transmission line arresters ranging from medium to high voltages. Hubbell operates in United States, Canada, Puerto Rico, Italy, Brazil, Switzerland and the United Kingdom. [17]



Fig. 5-7: Hubbell Power Systems [17]

TOSHIBA
Leading Innovation >>>

Fig. 5-8: Toshiba [18]

Toshiba’s (Japan) history dates 140 years back to the past although the official name was changed to Toshiba as late as 1984. With its 200 000 employees it is among the biggest companies that produce surge arresters. Its surge arresters production began in 1930 so

they are also experienced in this field. Toshiba offers station (including GIS) and line arresters as well as their own varistors. There are also some accessories available in their catalogues. Their voltage scale ranges from medium to high voltages. Toshiba operates in 30 countries around the globe. [18]

5.1 Comparison

Tab. 5-1: Product range

Producer	Type	Rated voltages ¹		Continuous operating voltage		Residual voltage ²	Discharge currents	Discharge classes	Mechanical load		Short-circuit	Specific energy ³	Housing
		(U _n) [kV]	(U ₁) [kV]	(U ₁) [kV]	(U ₂) [kV]				[Nm]	[Nm]			
Treltha [6]	design 0	6-360	4,8-288	15,2-961	10,20	2,3,4	2,3,4	6900	2800	40-50	4,5/6,7/9,2	porcelain	
	design I	6-420	4,8-336	15,6-1099	10,20	3,4	3,4	13800, 29000	5400, 9200	40-63	6,7/9,2	porcelain	
	design II	150-612	122-490	364-1457	20	4,5	4,5	29100, 35000	11640, 14000	40-63	9,2/13	porcelain	
	Varsil	5-144	4-116	12,3-391,7	10	2,3	2,3	-	-	63	-	polymer - solid core	
	SRK/T6	6-444	4,8-355	15,2-1151	10,20	3,4	3,4	12000, 29000	-	50-63	6,7/9,2/10	polymer - tube	
	SRK 6	6-360	4,8-288	16-961	10,20	3,4	3,4	3500, 4000	2800	63	6,7/9,2	polymer - cage	
Tecomativity [7]	PAA	9-60	7,2-120	26,5-199	10	2	2	3500	2500	40	4,1	polymer - cage	
	PBA	9-150	7,2-120	28,1-412	10	2	2	1000	600	65	6,4	polymer - cage	
	PCA	9-360	7,2-288	29,2-894	10	3	3	2500	2000	65	7,8	polymer - cage	
	MMA	9-198	7,2-158	26,5-530	10	2	2	12500	5000	40	4,5	porcelain	
	MCA	9-396	7,3-317	28,6-1053	10	3	3	12500	5000	65	8,75	porcelain	
	MDA	108-396	86-432	299-1042	20	4	4	12500	5000	65	11	porcelain	
Madedan Power Systems ⁴ [8]	MEAX	180-488	144-374	488-1245	20	5	5	14000	5600	65	13	porcelain	
	ZIP	3-144	2,55-115	8,09-374	10	2	2	565	-	50	5 ²	polymer - wrapped	
	ZIP	2,55-36,5	2,55-36,5	8,09-119	10	2	2	81,35 ²	-	20	5 ²	polymer - wrapped	
	ZSP	3-216	2,55-174	7,49-525	10	2	2	1130 ²	-	80	6,1 ²	polymer - wrapped	
	UI	3-108	2,55-84	8,3-273	10	-	-	45 ²	460, 920, 1600	40	3,9 ²	polymer - wrapped	
	U2 U3 U4	3-240	2,55-190	7,8-618	10,20	2,3,4	2,3,4	460, 680, 1150, 2000	460, 920, 1600	40, 63	2,7/5,1/8,3	polymer - wrapped	
Cooper Power Systems ⁵ [11]	AZG	3-360	2,55-289	8,1-886	10,20	2,3,4	2,3,4	4080 ² , 5420 ²	-	40, 63	2,7/4,5/7,2	porcelain	
	AZE	3-360	2,55-289	8,4-836	10	-	-	4657 ² , 5423 ²	-	40, 65	3,4 ² /5,6 ² /8,9 ²	porcelain	
	US, UH, UK	3-240	2,55-190	7,4-578	10	-	-	678 ² , 904 ² , 1382 ²	-	63	3,9 ² /6,2 ² /10 ²	polymer - wrapped	
	UW1	3-360	2,55-289	7,3-811	10	-	-	3616 ² , 4196 ²	800, 1000, 2500, 6000	63	15 ^{2,5}	polymer - wrapped	
	PEXUM	18-444	14,4-349	46,7-1111	10,20	2,3,4	2,3,4	1300, 1600, 4000, 9000	1400, 1900	40, 50, 65	2,5/4,5/7	polymer - cage	
	TEXUM	90-444	72-349	212-1111	10,20	3,4,5	3,4,5	21000, 28000	3000, 7200	65, 80	8 ² /11 ² /7/10	polymer - tube	
ABB [12]	EXUM	24-624	19,2-489	56,4-1488	10,20	2,3,4,5	2,3,4,5	7500, 18000	-	50, 65	2,5/4,5/7/10	porcelain	
	3EQ	30-612	24-489	79,5-1474	10,20	2,3,4,5	2,3,4,5	6000, 36000, 72000	-	50, 65, 80	8/19/27	polymer - tube	
	3EL	3-420	2,4-336	8,6-1109	10,20	2,3,4	2,3,4	500, 1200, 4000	-	20, 65	4,4/5/8/10	polymer - cage	
	3EP	10-612	8-489	26,5-1474	10,20	2,3,4,5	2,3,4,5	2000, 4500, 12500, 34000	-	40, 65, 100	8/13/25	porcelain	
	PVI-LP	3-72	2,55-57	8,1-188,4	10	-	-	339 ²	-	16,1	6	polymer - wrapped	
	EVP	3-228	2,55-180	7,6-548	10	-	-	1130 ²	-	63	9	polymer - wrapped	
Hubble power systems ⁶ [17]	VL	3-48	2,55-39	8-120	10	-	-	3164 ⁴	-	65	9	porcelain	
	MMN	54-444	42-353	122-1023	10	-	-	6779 ⁴	-	65	13	porcelain	
	SVN	18-444	15,3-353	44-1024	10	-	-	3954 ⁴	-	65	13	polymer - tube	
	RVLQD	3-492	-	8,4-1293,6	10,20	2,3,4,5	2,3,4,5	-	-	50, 65	4,5 ² /7 ² /11 ² /15 ²	porcelain	
Toshiba [18]	RVLQD	3-210	-	7,35-514,5	10	2,3	2,3	-	-	65	4,5 ² /6 ² /8,5 ²	polymer (unspecified)	

¹ Listed residual voltages are always related to lightning impulse & 20µs nominal discharge current.

² Representing one single impulse energy handling capacity related to rated voltage.

³ MCOV (maximum continuous operating voltage) according to american standard IEEE C62.11-2005 is provided instead of U₁ (continuous operating voltage) from IEC 60099-4. Also the arrester are often not rated with line discharge class.

⁴ Carrier maximum working load according to american standard IEEE C62.11-2005.

⁵ This value is related to continuous operating voltage, not rated voltage as usual.

⁶ Value of double impulse energy capability.

6 CONCLUSION

Testing of MOSA according to IEC 60099-4 standard is analysed in the chapter 4. I have sorted the tests from the standard into different categories for better clarity. The most important part is definitely the type tests chapter which covers tests that are necessary for each new arrester design. This chapter is primarily designated for porcelain housed arresters and the other design's tests are based on it. The most important type tests are operating duty tests and long-duration current impulse withstand test, which in a way describe the arresters energy handling capability and the latter also assigns the arrester with line discharge class (chapter 3.5.3). Routine tests, on the other hand, are necessary for each manufactured arrester. At the end of the standard, there are also many annexes, which extend the tests' details.

However, the standard is still not perfect will be soon changed and improved (chapter 4.3). There are few works that thoroughly analyze the standard (for example [19],[20]) and suggest improvements. The next biggest changes will probably be related to the line discharge class which is not easily comparable and therefore many manufacturers provide other non standardized properties resulting in chase for better values by changing the test parameters randomly. Some parts of the standard are also just historical remains lacking purpose for nowadays technology. There are also efforts to harmonize the IEC, IEEE and other standards better.

To summarize the manufacturers' comparison, let's have a look at the Tab. 5-1. Unfortunately not all the data obtained from the manufacturer's websites are comparable, because some of the companies are American and they use IEEE standards instead of IEC. Also some mechanical data are missing on the internet for some manufacturers or certain designs.

We can notice that every manufacturer except MacLean power systems has porcelain housings in their catalogues even though polymer housings have better performance in many respects (for example in polluted conditions,...). This suggests that polymer housing is still quite a new technology. For some conservative users it has not proven itself enough yet and there is much more service experiences on porcelain design available. Moreover porcelain housings also reach the highest voltages of all. MacLean Power Systems is the only manufacturer who reaches considerably lower rated voltages than the others which have a really wide range of continuous operating, rated and residual voltages. The highest voltages of all reach ABB's EXLIM, Tridelta's design II and Siemens' 3EP and 3EQ. Only Siemens has achieved to reach the same voltages with both porcelain and polymer housings.

In addition Siemens is the only manufacturer that provides arresters with short-circuit capability of 100 kA. Others vary from 20 kA to 65 kA, with exception for Siemens' and ABB's tube designs which reach 80 kA.

Most of the companies offer 10 kA and 20 kA discharge current surge arresters, only MacLean Power Systems and Hubbell Power Systems are the exceptions which offer only 10 kA arresters.

Discharge class is not defined in American standard, but from the rest all discharge classes except for line discharge class 1 are manufactured. Even though MacLean Power Systems use IEEE standard, they also claim that the arresters properties exceed discharge class 2

requirements. Every company that uses IEC standard has arrester's line discharge classes 2, 3, 4 and 5.

The mechanical data is quite hard to compare because they are differently defined in each standard, but again, highest values are reached by Siemens, ABB and Tridelta.

As noted in the table, it is also hard to compare the specific energy of arresters because they are either related to different voltage or the values are considered for double impulses. Nevertheless, Siemens again reaches incredibly high values.

Incredible values have been reached by the biggest manufactures in general and even though I haven't mentioned TE connectivity in the conclusion yet, they do not get much behind Siemens, ABB and Tridelta and they are successfully catching up the modern market demands with their products.

However the progress of developing surge arresters is going to continue in the future as the transmission and distribution lines are getting more technologically advanced and higher voltages are reached.

Manufacturers has made a huge progress since the first Diviš's lightning rod invention, but it is still not even close to the end mostly because the energy itself becomes a global problem and therefore it creates a greater requirements for the technology of power systems.

REFERENCES

- [1] HINRICHSSEN, Volker. SIEMENS AG. *Metal-Oxide Surge Arresters in High-Voltage Power Systems: Fundamentals*. 3rd edition. Erlangen, 2012. Available from: http://www.energy.siemens.com/mx/pool/hq/power-transmission/high-voltage-products/surge-arresters-and-limiters/aboutus/Arrester_Book_Ed%20_3_en.pdf
- [2] *Arrester Works: the surge protection resource center for power systems* [online]. 2007-2010 [cit. 2014-02-23]. Available from: <http://www.arresterworks.com/>
- [3] Prokop Diviš. In: *Wikipedia: the free encyclopedia* [online]. San Francisco (CA): Wikimedia Foundation, 2001- [cit. 2013-11-07]. Available from: http://en.wikipedia.org/wiki/Prokop_Divi%C5%A1
- [4] VARGA, Jiří. *Přepětí v elektroenergetice*. Liberec, 2011. Available from: http://home.zcu.cz/~jvarga/TVN/prepeti_energetika.pps
- [5] *Transmission Line Surge Arrester - White Paper* [online]. 2005 [cit. 2013-11-10]. Available from: <http://www.epri.com/abstracts/Pages/ProductAbstract.aspx?ProductId=00000000001010233>
- [6] Surge Arresters. *Tridelta* [online]. 2007 [cit. 2013-11-17]. Available from: <http://www.tridelta.de/tridelta-ueberspannungsableiter-gmbh-en.html>
- [7] Surge Arresters. *TE connectivity* [online]. 2013 [cit. 2013-11-17]. Available from: <http://www.te.com/en/industries/energy/energy-global/browse-products/surge-arresters/transmission.html>
- [8] Arresters. *Maclean Power Systems* [online]. 2013 [cit. 2013-11-17]. Available from: http://www.maclepower.com/products/index.asp?DEPARTMENT_ID=2854
- [9] Surge Arresters. *ABB* [online]. 2013 [cit. 2013-11-17]. Available from: <http://www.abb.com/product/us/9AAC710009.aspx>
- [10] Surge Arresters & Limiters. *Siemens* [online]. 2012-2013 [cit. 2013-11-17]. Available from: <http://www.energy.siemens.com/hq/en/power-transmission/high-voltage-products/surge-arresters-limiters/>
- [11] Surge Arresters. *Cooper Power Systems by Eaton* [online]. 2013 [cit. 2013-11-17]. Available from: http://www.cooperindustries.com/content/public/en/power_systems/products/surge_arresters.html
- [12] ABB HIGH VOLTAGE TECHNOLOGIES LTD. *Dimenzování, zkoušení a používání svodičů z oxidů kovů v sítích vysokého napětí*. Wettingen, Švýcarsko, 1994.
- [13] IEC 60099-4. *Surge arresters: Part 4: Metal-oxide surge arresters without gaps for a.c. systems*. Edition 2.2. Geneva: International Electrotechnical Commission, 2009.
- [14] [CIGRÉ], Working group A3. *MO surge arresters: stresses and test procedures*. [Paris] (21 rue d'Artois, 75008): CIGRÉ, 2013. ISBN 978-285-8732-395.
- [15] HP Series Medium Voltage Polymer Surge Arrester. *Polipar Energy Systems* [online]. 2010 [cit. 2014-02-23]. Available from: <http://www.polipar.com.tr>
- [16] HINRICHSSEN, Volker. TECHNISCHE UNIVERSITÄT DARMSTADT. *Lecture Notes: Metal Oxide Surge Arresters*. Darmstadt, 2014.

-
- [17] Arresters. *Hubble Power Systems* [online]. 2001-2014 [cit. 2014-03-20]. Available from: <http://www.hubbellpowersystems.com/arresters/>
- [18] Surge Arresters. *Toshiba: Leading innovation* [online]. 1995-2014 [cit. 2014-03-20]. Available from: <http://www.toshiba.co.jp/sis/en/tands/surge/index.htm>
- [19] HINRICHSEN, Volker, Max REINHARD a Bernhard RICHTER. CIGRÉ WG A3.17. *Energy Handling Capability of High-Voltage Metal-Oxide Surge Arresters: Part 1: A Critical Review of the Standards*. Rio de Janeiro, 2007.
- [20] RICHTER, Bernhard. CIGRÉ WG A3.17. *A Critical Review of the Actual Standard IEC 60099-4: Metal-Oxide Surge Arresters Without Gaps for a.c. systems*. Rio de Janeiro, 2007.
- [21] What is cigre?. CIGRE. *Cigre: The forum for electrical innovations* [online]. 2014 [cit. 2014-03-27]. Available from: <http://www.cigre.org/What-is-CIGRE>
- [22] Index of suppliers by type of product: Arresters. *INMR: Buyer's guide & directory*. 2013, vol. 21, quater 4.
- [23] E-mail conversation between the author and Mr. Adriano Dellallibera, application engineer from Balestro, 29.1.2014.