



**BRNO UNIVERSITY OF TECHNOLOGY**

VYSOKÉ UČENÍ TECHNICKÉ V BRNĚ

**FACULTY OF MECHANICAL ENGINEERING**

FAKULTA STROJNÍHO INŽENÝRSTVÍ

**ENERGY INSTITUTE**

ENERGETICKÝ ÚSTAV

**ELIMINATION OF NANOPLASTICS BY  
CAVITATION AND ADVANCED OXIDATION  
PROCESSES**

ELIMINACE NANOPLASTŮ KAVITACÍ A POKROČILÝMI OXIDAČNÍMI PROCESY

**BACHELOR'S THESIS**

BAKALÁŘSKÁ PRÁCE

**AUTHOR**

AUTOR PRÁCE

Júlia Kluknavská

**SUPERVISOR**

VEDOUCÍ PRÁCE

doc. Ing. Pavel Rudolf, Ph.D.

**BRNO 2021**



# Assignment Bachelor's Thesis

Institut: Energy Institute  
Student: **Júlia Kluknavská**  
Degree programm: Engineering  
Branch: Fundamentals of Mechanical Engineering  
Supervisor: **doc. Ing. Pavel Rudolf, Ph.D.**  
Academic year: 2020/21

As provided for by the Act No. 111/98 Coll. on higher education institutions and the BUT Study and Examination Regulations, the director of the Institute hereby assigns the following topic of Bachelor's Thesis:

## **Elimination of nanoplastics by cavitation and advanced oxidation processes**

### **Recommended bibliography:**

PAUL, Maxi B., Valerie STOCK, Julia CARA-CARMONA, et al. Micro- and nanoplastics – current state of knowledge with the focus on oral uptake and toxicity. *Nanoscale Advances*. 2020, 2, 4350-4367.

MARŠÁLEK, B.; MARŠÁLKOVÁ, E.; ODEHNALOVÁ, K.; POCHYLÝ, F.; RUDOLF, P.; ŠTAHEL, P.; RÁHEL, J.; ČECH, J.; FIALOVÁ, S.; ZEZULKA, Š. Removal of *Microcystis aeruginosa* through the Combined Effect of Plasma Discharge and Hydrodynamic Cavitation. *Water*, 2019, roč. 12, č. 1, s. 1-14. ISSN: 2073-4441.

Deadline for submission Bachelor's Thesis is given by the Schedule of the Academic year 2020/21

In Brno,

L. S.

---

doc. Ing. Jiří Pospíšil, Ph.D.  
Director of the Institute

---

doc. Ing. Jaroslav Katolický, Ph.D.  
FME dean



## **ABSTRACT**

The Present Thesis deals with nano and microplastics pollution of the environment and with possible elimination thereof. The thesis includes a research and an experimental part. The research describes the issues of micro and nanoplastics in terms of their formation, dispersion into the environment and into the living organisms. The research part concludes with description of current solutions of micro and nanoplastics elimination from the wastewater. The current wastewater treatment solutions are in particular based on filtration method which by definition may not be absolute. There was an assumption pronounced that using CaviPlasma device may render elimination of micro and nanoplastic from wastewater. The aim of the thesis was to experimentally verify that assumption. Test sample used was the suspension of water and polyamide particles which was subsequently exposed to the cavitation and plasma discharge. The experiment did not result in elimination of particles, nor visible disruption thereof. However, it was shown that plasma discharge may initiate the agglomeration of the particles to such an extent that continuous structures of microplastics are observed. This phenomenon may potentially be beneficial for microplastics filtration.

### **Key words**

Nanoplastics, microplastics, cavitation, plasma discharge, CaviPlasma, wastewater treatment

## **ABSTRAKT**

Táto práca sa zaoberá znečistením životného prostredia mikro a nanoplastami a ich možnou likvidáciou. Práca pozostáva z rešeršnej a experimentálnej časti. V rámci rešerše je opísaná problematika mikro a nanoplastov z hľadiska ich vzniku, disperzie do životného prostredia a živých organizmov. V závere rešeršnej časti sú opísané súčasné možnosti eliminácie mikro a nanoplastov pri čistení odpadových vôd. Súčasná riešenia sú založené prevažne na filtrácii, ktorá však zo svojej podstaty nemôže byť absolútna. Bol vyslovený predpoklad, že pomocou zariadenia CaviPlasma by bolo možné eliminovať mikro a nanoplasty z odpadových vôd. Cieľom práce bolo experimentálne overiť tento predpoklad. Skúšobnou vzorkou bola suspenzia vody a polyamidových častíc, ktorá bola následne vystavená pôsobeniu kavitácie a plazmového výboja. Pri experimente nedošlo ku zničeniu častíc a ani ich k viditeľnému porušeniu. Ukázalo sa však, že plazmový výboj môže iniciovať zhlukovanie sa častíc až do takej miery, že sú pozorovateľné kontinuálne štruktúry mikroplastov. Tento jav by mohol byť potenciálne prospešný pri zachytávaní mikročastíc filtráciou.

### **Kľúčové slová**

Nanoplasty, mikroplasty, kavitácia, plazmový výboj, CaviPlasma, čistenie odpadových vôd

## **BIBLIOGRAPHIC CITATION**

KLUKNAVSKÁ, Júlia. Elimination of nanoplastics by cavitation and advanced oxidation processes [online]. Brno, 2021 [cit. 2021-05-21].

Available also at: <https://www.vutbr.cz/studenti/zav-prace/detail/132405>. Bachelor's thesis. Brno University of Technology, Faculty of Mechanical Engineering, Energy Institute. Supervisor Pavel Rudolf.

## **DECLARATION**

I declare that I have personally compiled the thesis "Elimination of nanoplastics by cavitation and advanced oxidation processes" according to the instruction of my supervisor, doc. Ing. Pavel Rudolf, Ph.D. and with the use of the sources listed in bibliography.

.....  
Date

.....  
Júlia Kluknavská

## **ACKNOWLEDGMENT**

I would like to thank doc. Ing. Pavel Rudolf, Ph.D. for his professional guidance throughout processing the Present Thesis, to doc. Mgr. Pavel Šťáhel, Ph.D. and Mgr. Jana Jurmanová, Ph.D. from MUNI, for their assistance provided in experiment performance and samples evaluation.

I would like to express my special thanks to Ing. Ondřej Vaverka for consultations and to Ing. Ivan Novosád, MUDr. Jana Kluknavská and Ing. Jaroslav Kluknavský, Ph.D. for their great and endless mental support. For language correction of this thesis, my gratitude goes to Mgr. Rastislav Majorský.

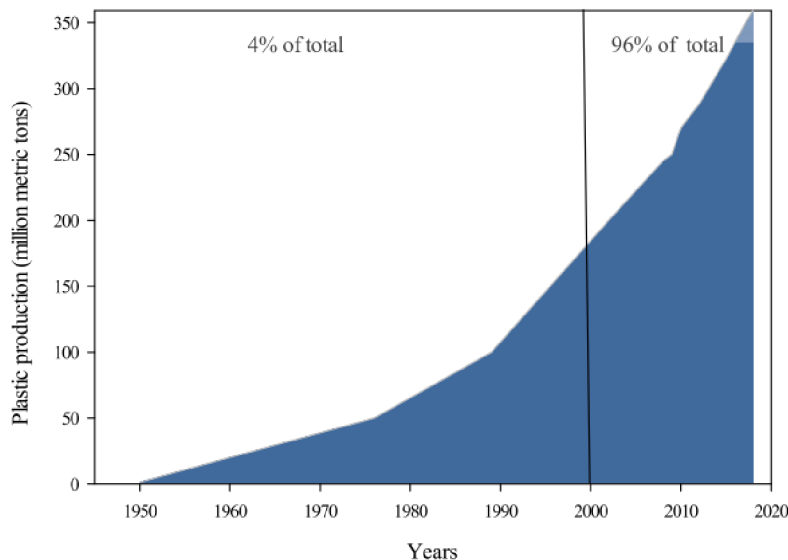


## TABLE OF CONTENTS

<b>INTRODUCTION .....</b>	<b>10</b>
THE AIMS OF THE THESIS .....	11
<b>1 THE MAIN PROPERTIES OF PLASTICS .....</b>	<b>12</b>
1.1 Fragmentation from Microplastics (MPs) to Nanoplastics (NPs) .....	12
1.2 The Character of MPs/NPs Behaviour according to the DLVO Theory .....	13
1.3 Homogeneous Interactions between Nano or Microplastics .....	14
1.4 Heterogeneous Interactions between Nano/Microplastics and Other Entities .....	15
<b>2 ACCUMULATION OF MPS/NPS .....</b>	<b>16</b>
2.1 Accumulation in Water .....	16
2.2 Accumulation in Soil .....	16
2.3 Accumulation and Occurrence in Organisms .....	17
2.4 Leaks of Chemical Substances .....	19
<b>3 WASTEWATER TREATMENT PLANTS AND NANOPLASTICS .....</b>	<b>21</b>
3.1 Filtration (Current Trends) .....	22
3.1.1 Ultrafiltration (UF) .....	23
3.1.2 Membrane Bioreactor (MBR) .....	25
<b>4 CAVITATION .....</b>	<b>27</b>
4.1 CaviPlasma .....	28
<b>5 EXPERIMENT .....</b>	<b>30</b>
5.1 Description of the Experiment .....	30
5.2 Results .....	30
<b>DISCUSSION .....</b>	<b>35</b>
<b>CONCLUSION .....</b>	<b>36</b>
<b>REFERENCES .....</b>	<b>37</b>
<b>LIST OF ABBREVIATIONS .....</b>	<b>41</b>

## INTRODUCTION

The environment pollution, especially caused by so called micro or nanoplastic particles, belongs among frequently discussed topics of nowadays. The main problem connected to plastics materials is their prevalence throughout the industry branches. Plastics are, due to a wide range of properties ubiquitous. Thanks to their lightweight, high strength and durability, plastics has become an inseparable part of human life.



**Figure 0.1** Total plastic production in the world [1]

As recent years, however show, wrong treatment of plastic waste leads to great environment pollution. In the last decades, quantity of plastics production has risen exponentially worldwide. When plastics began to be produced, in 1951, yearly production was 1,5 million tons. On the other hand, in 2016 yearly production was 350 million tons [2] (Figure 0.1). Consequently, 13 million tons of plastics are deemed to be released into the oceans. If this gradient is kept, in 2025 predicted cumulative quantity of plastic waste discharged into rivers and oceans will be around 250 million tons. In present, about three quarters of the plastic waste mass are dispersed into the environment, 8% is stored in landfill and just 20% is recycled or used for energy recovery [3].

Major sources of microplastic found in the ecosystems are drainage systems, abrasion from car tires, runoff from agricultural land or effluent of wastewater treatment plants. That is just why microplastics are found in the world oceans as well as in the Arctic, mountain lakes and atmospheric fallout [4]. Nanoplastics are, however, also found in what is left after usage of industrial abrasives or personal care products as exfoliators (chemical or mechanical peelings) [5]. Hence, potential risk for human health has been appeared. As recent studies demonstrate, microplastics have been identified in sea food, bottled water, commercial salts, beer, honey [6] or leaking from triangle tea bags [7]. However, greater risk for human health is represented by nanoplastics. Their size enables them to penetrate organic tissues passively without activation energy or any other impulse [4].

## **THE AIMS OF THE THESIS**

The first aim of this thesis is to describe the current state of knowledge about micro and nanoplastic particles, their behaviour and interaction with other entities in the environment, especially during wastewater treatment process, including harmful effects thereof. As recent studies [3], [8] indicate, wastewater treatment plants may, paradoxical, contribute to the global micro/nanoplastic water pollution<sup>1</sup>. Hence, in order to inhibit global water polluting, it flows a need for micro / nanoplastics detection and elimination thereof.

The second aim of the thesis is experimental verification of effectivity of CaviPlasma device (chapter 4.1), which may possibly destruct micro or nanoplastic particles in water and consequently may be potentially involved as a last step of wastewater treatment process.

---

<sup>1</sup> The water pollution is caused by unwanted fragmentation of those particles into smaller ones by wastewater treatment process (*e.g.*, rapid sand filtration – chapter 3) and consequently not sufficient filtration of wastewater in last step of the treatment.

## 1 THE MAIN PROPERTIES OF PLASTICS

Types of plastics most widely used in industrial applications include polyethylene (PE), polypropylene (PP), polystyrene (PS), polyethylene terephthalate (PET), polyurethane (PU) and polyvinyl chloride (PVC) [2]. Most micro- and nano- plastic particles found in fauna and flora and wastewaters as well (Table 1) are therefore PE, PP and PS [9].

Most frequent method of plastics production is using feedstocks derived from natural gas processing or crude oil refining. Materials resulting from that type of production are synthetic or semi-synthetic organic polymers [2]. Thus their degradation is provided for decades only through weathering and ageing and small particles as micro ( $10^{-6}$  m) or even nano ( $10^{-9}$  m) plastics are continuously separated [3]. Particles of 1-100 nm in diameter are considered nanoparticles, while particles ranging from 0,1 to 5000  $\mu\text{m}$  in size are classified as microparticles [9].

**Table 1**

Density and abundance of the most frequent plastic particles in waste water [3]

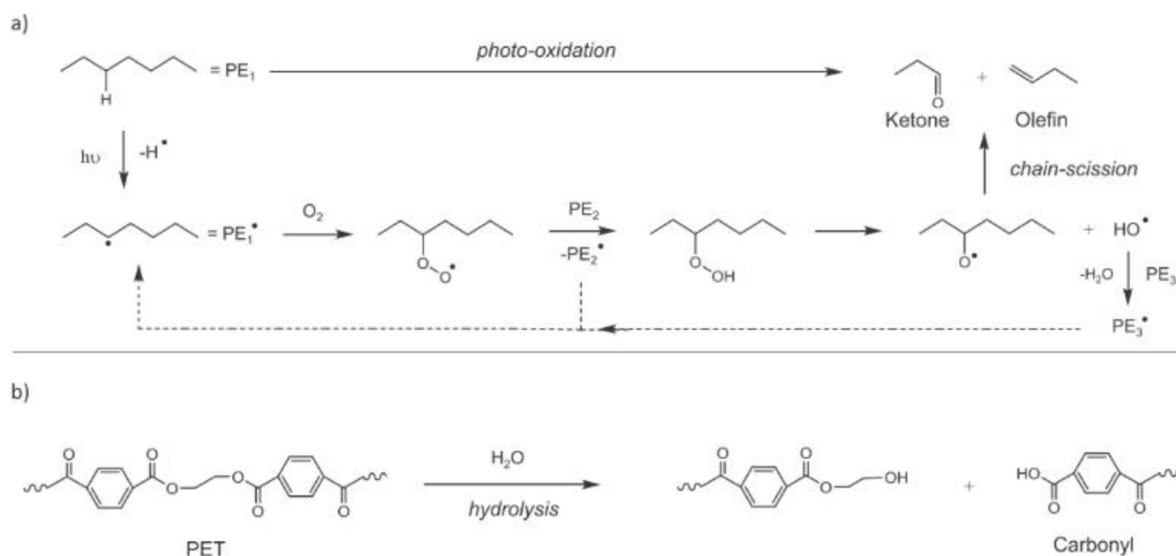
Material	Density at 20°C (g/cm <sup>3</sup> )	Abundance in wastewater
Water	1,00	-
Polyethylene	0,90 – 0,98	45%
Polypropylene	0,84 – 0,91	21%
Polyester	1,10 – 1,12	16%
Polyethylene terephthalate	1,30 – 1,40	7%
Polystyrene	1,04 – 1,06	6%
Polyamide	1,05 – 1,14	5%

### 1.1 Fragmentation from Microplastics (MPs) to Nanoplastics (NPs)

The way of plastics fragmentation depends on different mechanisms, which can be present either individually or may compound. The most common are mechanical fracture, photooxidation (Scheme 1 a) when exposed to UV light (especially in the water), hydrolysis, water turbulence or bio-assimilation by microorganisms. Since acidic conditions make hydrolysis autocatalytic, hydrolysis rate is increased and degradation of a polymer chain occurs. Hence, hydrolysis is most common process of polymers degradation in water (Scheme 1 b) [3].

As direct result of photooxidation and hydrolysis, cracks and fractures are formed on the surface of the plastic parts. Weakened particles can easily crumble away into micro plastics due to mechanical stress which may be caused by friction, abrasion or plastic embrittlement. It is supposed that surface erosion appears just before bulk fragmentation into microplastics. It is necessary to say that mechanism of fragmentation depends on many qualities such as polymer type, used additives, strength and toughness of plastic material, environmental conditions or even manufacturing process [10].

It was discovered that PS sheet which were extruded at 290°C show lower strength value by 29% due to high levels of stress intrinsically emerged from the manufacturing process. The residual stress may not be visible at first sight but may appear during the usage of the item. Stress cracking is more likely to be prevalent in particles which reached its end of life and subsequently they fragment into microplastics easily [3].



**Scheme 1** Degradation mechanisms of frequent polymers. a) Photo-degradation of PE by UV and b) degradation of PET by hydrolysis [3]

But mechanism of fragmentation does not stop at microplastics separation. It is proved that microplastics keep splitting into hardly detectable nanoplastics. This down to 30 nm in-size particles were reported after some PP, PS and PE pellets were exposed to outdoor aquatic environment. Defects which weaken particle surface arise when microplastics end in water [11]. Creation of those defects depends on the tensile strength and the elasticity modulus of the material. Supposed failure of microplastics into nanoplastics is enhanced by the environmental stress cracking potentiated by environmental factors (*e.g.*, water turbulence), but no data are available so far [12].

When nanoplastics are separated, they may create agglomerates, or may disperse. It all depends on surrounding conditions such as concentration of exopolymeric substances<sup>2</sup> (EPS). When EPS level is low, hydrophobic properties of micro/nanoplastic particles are to a large extent negated and dispersion of plastic particles is promoted. Nonetheless, EPS are not the only activators of dispersion, wastewater treatment plants (WWTPs) also contribute to this process to a large extend due to generating the shear forces during the treatment [8].

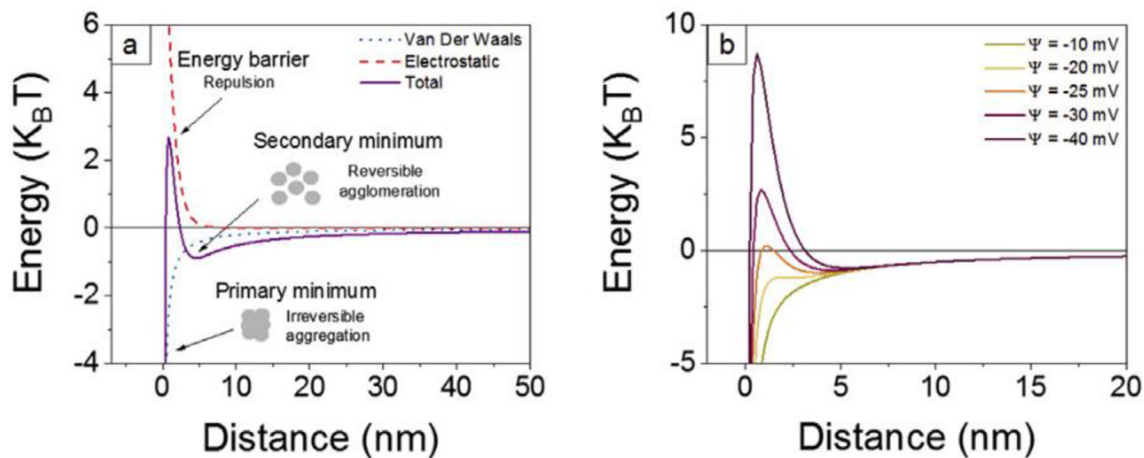
## 1.2 The Character of MPs/NPs Behaviour according to the DLVO Theory

Shear forces which affect nanoplastics in water may be better understood by application of Derjaguin, Landau, Verwey, Overbeek (DLVO) theory which describes the stability of colloid in the water [3].

<sup>2</sup> EPS is a product of aquatic micro-organisms. It is a major component of the dissolved organic matter in water and creates a biofilm. The agglomeration of micro or nanoplastics is directly influenced by EPS, because EPS may act as a binding agent. The possible inhibition of hydrophobic properties of MPs/NPs by EPS is experimentally proven [14].

The dependence between Van Der Waals forces, electrostatic forces and interparticle distance  $h$  in connection with NPs interaction in the water is shown in the Figure 1.1. When electrostatic repulsion energy  $V_{edl}$  and Van der Waals attraction energy  $V_{vdw}$  are in equilibrium ( $V_{total}(h) = V_{vdw}(h) + V_{edl}(h)$ ), particles form stable structures in the water with relatively constant interparticle distances (e.g., agglomerates or aggregates). However, affection by external forces leads to changes in this interparticle distance and destabilization of particles clusters. There may occur two limit conditions [3].

Stage of secondary minimum (the first limit condition) in potential energy means that particles are agglomerated in a reversible loose pattern. By providing sufficient kinetic energy to the particles, primary minimum (the second limit condition) is reached by overcoming the energy barrier and that means formatting of irreversibly dense aggregate [3].



**Figure 1.1** DLVO theory application to polyethylene (PE) particles in wastewater.

a) agglomeration of 50 nm particles with surface potential  $\psi = -30$  mV, b) dependence of particles agglomeration on their surface potential [3].

Note:  $1 \text{ k}_B\text{T} = 4,142\text{e}^{-21}\text{J}$  at room temperature 300 K [13]

In conclusion it may be said, that nanoplastic particles in water may agglomerate or disperse depending on kinetic energy which is given to them from various sources or causes. Hence, there is direct relation between the influence of the surrounding environment (such as a case with EPS) and nanoplastic behaviour.

### 1.3 Homogeneous Interactions<sup>3</sup> between Nano or Microplastics

Plastic particles in water are likely to have negative surface charge due to hydrophobic nature of majority plastic materials. This hydrophobic nature enhances the absorption of hydroxide ions and creates negative surface charge [3]. However, behaviour of micro and nanoplastics in water is different. While MPs in all water quality conditions do not evince tendency to assemble without affection of external force (e.g., turbulent water flux), NPs have this tendency to assemble and create homogenous agglomerates due to Brownian motion. Hence, MPs can easily

<sup>3</sup> Under the term “homogeneous interactions” is understood behaviour among plastic particles of micro or nano scale as such, excluding the other entities from those interactions.

discharge into the water environment and due to chemical or photolysis process may degrade into NPs by transport [5]. More described in chapter 3.

#### **1.4 Heterogeneous Interactions between Nano/Microplastics and Other Entities**

Micro and nanoplastics are able to tie together with surroundings particles, which includes organic matter as well. Thus, when in water, they form agglomerates with the associated microbial community – bacterial glycoprotein exopolymeric substances (EPS) [14]. Moreover, additives used in production of plastics and ability of particles to absorb chemicals present in water change the surface chemistry of micro/nanoplastics and affect how they agglomerate or disperse [3].

Although, the surface of separated particles is smooth and hydrophobic, particles floating on the sea surface interact with their surroundings in water and consequently they easily absorb contaminants by wrapping their surface with organic matter, nutrients, bacteria from the water column or various sediments and consequently “ecocorona” is created. It is necessary to say, that settlement of micro or nano particles in the water column depends on the type of polymer (*e.g.*, its density, see Table 1), surface chemistry and composition of microbial biofilm. Concentration of contaminants in microplastic particles caused due to absorption seems to be significantly higher than expected and may lead to higher accumulation in organisms [6].

## 2 ACCUMULATION OF MPS/NPS

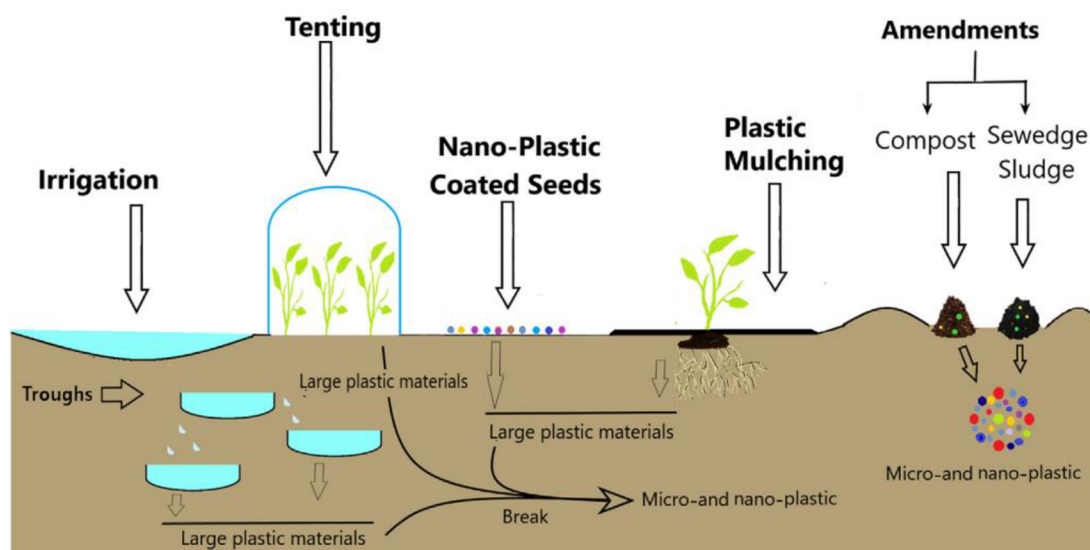
As far as it is known, there exist three major ways of micro/nanoplastics accumulation. They may create aggregates in water, soil or directly in organic tissues of animals or humans, but data on the third way are scarce so far. The possible option of micro/nanoplastics intake is direct consumption of plastic aggregates created in water or soil [2].

### 2.1 Accumulation in Water

Despite microplastics having originally lower density than water, formation of biofilm causes hidden presence of those particles in deep sediments (from 5 to 60 cm below water surface) in amounts five times higher than if there were no biofilm effect among surface sediments. It is probable, that microplastic pollution of water columns is underestimated as 80% of samples of microplastic particles studied exceeded 300  $\mu\text{m}$  and so smaller particles were excluded [2]. For example, 30 nm polystyrene nanoparticles are able to rapidly form aggregates in seawater of millimetres in length. Moreover, there is a natural tendency to form aggregates in artificial seawater due to higher zeta potential [6], where zeta potential is related to the surface charge of the nanoparticles. It is an electrostatic potential difference between the layer of ions, which are strongly bound to the particle surface and diffuse outer layer of loosely associated ions [15].

### 2.2 Accumulation in Soil

When speaking about micro/nanoplastics gathering, agricultural landscape must be considered, too. Consistent efforts to fertilize farmland result in great amounts of plastic particles dispersion into soil (Figure 2.1). Large contributors to this type of pollution are soil mulching and sewage sludge applications. Studies have shown that even though microplastics are effectively removed from wastewater, most of residuum particles not detected are transferred to the sludge [16]. Another harmful effect provide nano-coated seeds with fertilizers or pesticides. Fragmentation of those materials to micro or nanoplastics through UV, temperature, microbial and faunal processing leads to massive spreading of these fragments into soil [1].



**Figure 2.1** Pathways of micro and nanoplastics entrance in agricultural soils [1]



There are defined two main problems connected with agricultural soil and micro/nanoplastic particles. First one is desiccation process. The process is enhanced by plastics accumulation in soil which creates more channels for water movement. It leads to higher evaporation losses, whereas 2  $\mu\text{m}$  size plastics facilitating this process (compared to 5 and 10  $\mu\text{m}$  plastic particles which also do so, but in a lesser extent). However, the smaller particles are, the greater is their amount and the larger surface they create. Considering this idea, nano-sized plastics are expected to be more hazardous to soil and health of microbial community [1].

Second problem is soil pH and endangering proper function of microbial community. Soil pH seems to be reduced by high density polyethylene (HDPE). Microplastics tend to cause changes in natural environment for various microbial phylum from proteobacteria to actinobacteria [1]. Proteobacteria are responsible for nitrogen and sulphur fixation in soil [17] and actinobacteria contribute to global carbon cycling due to providing decomposition of soil organic matter and increasing plant productivity [18].

Spread fragments of plastics in soil can enter plant root system and block areas through which water and nutrients are delivered to the plant. But vigorous root system is essential for the plant growth and plant anchorage [1].

Hence, microbial fauna and flora are worth to giving a sight in connection with micro/nanoplastic pollution, too.

### **2.3 Accumulation and Occurrence in Organisms**

The above mentioned implies, that size and surface charge are important factors for uptake. It was proven, that plastic particles can cross the biological barriers of cell considering particles up to 1  $\mu\text{m}$  [4]. For instance, polystyrene particles of 50-100 nm in size were able to translocate across the lymphoid tissue of small intestine, which plays an important role in immune answer of the human organism, and intestinal villi, too. However, the uptake of 2,5 nm dendrimers was lower than uptake of 100-3000 nm polystyrene particles, thus it is possible to say, that size is not the only factor to take into account in micro/nanoplastics intake [19].

Great amount of nano/microplastics debris has spherical surface which enables easier ingestion thereof by living organisms and increases the risk of absorption of toxic contaminants by the organic tissues (see chapter 2.4) [3]. Higher particle concentrations may also raise the chance of interaction with epithelia and enable translocation of nanoplastics particles [4].

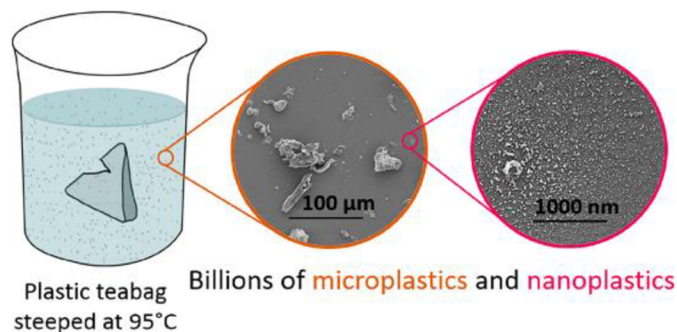
Several studies had shown [4], [6], [19] that chemicals released from plastics are able to transfer into animal tissues, accumulate there, be transfer to the next generation, or cause various defects. More research is required to prove harmful effect of micro/nanoplastics particles to human health. However, plastics pollutants were observed in the intestine, gills, liver and brain of the fish, but data on concentration of plastic particles in edible parts of the fish were not analysed in the study [6]. Although direct impact of nanoplastics to human body has not been proven yet, there is a study which declares indirect influence on the human organism. It was discovered, that when shrimps were exposed to nanoplastics environment, show significantly lower levels of EPA (eicosapentaenoic acid) than physiological values. EPA plays an important role by prevention of cardiovascular diseases and is a part of nutrients which humans take up by eating seafood [20].

What follows from the above-mentioned, micro/nanoplastics become a part of human environment and therefore it is necessary to find ways how to eliminate them because nowadays even a chicken viscera may include microplastics.

Presence and harmful effect of plastic particles in water are discussed nowadays in the context of possible consequences on the vertebrates. It was proven, that when carp feeds itself with invertebrates (which were previously exposed to nanoplastics), presence of polystyrene nanoparticles (53 and 180 nm) in the brain structure of the carp caused behavioural changes. Certain concentration of phthalates is also assessed in the blubber (whale fat) of stranded fin whales. Occurrence of phthalates has been reported in human breast milk, blood and urine, too [6]. Relating to humans, MPs  $\sim 10 \mu\text{m}$  in size were also found in human placenta tissue, but the way how those particles reach bloodstream remains unknown. However, the fact is, that presence of microplastics in human placenta may affect immunity mechanisms during pregnancy or even restrict growth of the foetus. To investigate the behaviour of MPs as a part of human placenta (*e.g.* potential of toxic contaminants releasing or immune responses) further studies need to be performed [21].

Another study is concerned with possible accumulation and distribution of PS microbeads in mice. Conclusion of that study implies accumulation in liver, kidney and guts, while the smaller the particle are, the higher accumulation thereof was. Presence of plastic particles was proved also in hepatic portal vein (the vein, which transports blood from the gastro intestinal tract, gallbladder, pancreas and spleen to the liver) of a dog [6].

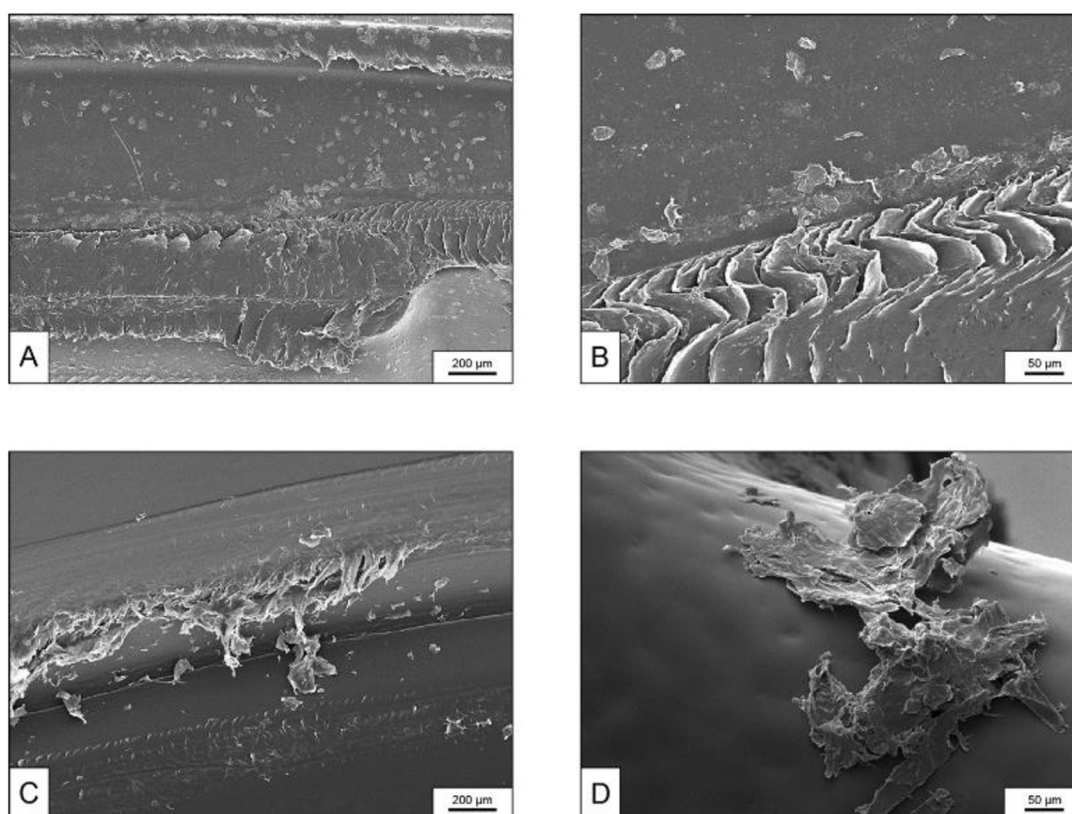
There are variety of sources of micro/nanoplastics in everyday human life. Recent study investigates releasing of those particles from polypropylene infant feeding bottles (PP-IFBs). As results show, PP-IFBs can release up to 16 million MPs and trillions of NPs per litre, while higher temperature of liquid enhances this process. Similar problem is related with PP plastic-ware products as kettles or lunchboxes [22].



**Figure 2.2** Steeping process and releasing of MPs/NPs [7]

Plastics teabags are another contributor of micro/nanoplastic pollution in food chain. During typical steeping process (Figure 2.2) of single plastics teabag in one cup of beverage 11,6 billion microplastics and 3,1 billion nanoplastics of nylon and PET are released [7]. Another study focused on other item used daily – PET plastic bottles.

The objects of research were bottle necks and caps of PET plastic bottles from 3 different manufacturers. It was discovered, that exposure to mechanical stress by repeated opening and closing the bottle causes significant changes on surface of both – bottle necks and caps (Figure 2.3), whereas effect on the cap was more destructive due to different hardness of PET and HDPE (hardness of HDPE caps is lower than that of PET bottle necks). Nearly 90% of HDPE particles released were under  $5 \mu\text{m}$ . Microplastic particles separated from PET plastics bottles present easy way of MPs intake by humans [23].



**Figure 2.3** SEM images of cap (A-C) and bottleneck (D) of plastic PET bottles after repeated opening/closing procedure (100 x) [23]

To sum it up, MPs and NPs are being integrated into human food chain. Microplastics under 130 µm in diameter have the potential to translocate into human tissues, release toxic chemicals (see chapter 2.4) including additives (such as phthalates) or pollutants absorbed from the environment and provoke immune response. But further research is needed to prove the direct effect of MPs or NPs on human health [24].

## 2.4 Leaks of Chemical Substances

Thus, potential hazard for organisms is not only caused by plastics in the form of solid unwanted particles which may *e.g.*, mechanically block blood circulation, but there is also risk of additions leaks.

To improve properties of plastics (extend the lifetime, resistance to heat, oxidation or microbial degradation) wide range of additives is used. Potentially most hazardous ones include phthalates which are predominantly used as plasticizers (in particular in PVC). These and others such as BPA (bisphenol A) which belongs among corrosive substances, or BRFs (brominated flame retardants) are released into the environment after fragmentation and degradation of plastics [3].

If these leaking chemical substances have opposing concentration gradients as biota lipids and are ingested by organisms, bioaccumulation may occur. This depends on the gradient between the chemical concentration in plastics and the surrounding water [6]. However, potential risk

does not only evince additives, but also chemicals which are able to bind to the plastic particles in water. The binding can be realised by two mechanisms depending on the plastics type.

Adsorption is typical in case of robust vitreous plastics (*e.g.*, PS, PVC) and strongly hydrophobic substances. This process results in entity fast and strong binding to the surface and in its inability to penetrate into the material.

On the other hand, absorption occurs in porous materials (*e.g.*, rubber, PE, PP) where chemicals are allowed to penetrate and diffuse into and out of the material. Hence, PET or PVC absorb less hydrophobic organic chemicals than PP or PE. But not only chemicals pose risk, also heavy metals like cadmium, copper or zinc may be ad- or absorbed, too [9].

### 3 WASTEWATER TREATMENT PLANTS AND NANOPLASTICS

Municipal WWTPs are one of the main sources of nanoplastics [8]. The reasons are shear forces generated by mechanical stirring of the wastewater which, according to the DLVO theory, break nanoplastics agglomerates and the fact, that mechanical filtration of these particles at the end of WWT process (described in chapter 3.1) cannot be absolute.

Nonetheless, forces which are generated during wastewater treatment process by mechanical stirring may cause dispersion of homogenous agglomerates of nanoplastic particles. Van der Waals forces can be broken by action of stirring process which generates shearing forces with sufficient kinetic energy. Therefore agglomeration of NPs in the water is possible but can be reversed as a result of shear forces activity [3].

One of the key knowledge on elimination micro and nanoplastic particles present in rivers, lakes or even oceans means to know how these particles behave while water is refining by waste water treatment plants (WWTPs), beginning with quantifying them.

Microplastic particles tend to fragment into nanoplastic particles precisely because of shear forces generated by mechanical stirring during WWTPs process. Thanks to decreased MPs concentrations in the effluents it may seem, that water treatment process results in catching and filtrating those particles. But it was reported that MPs particles may not be detected in effluent because great number of them fragments into NPs particles. The proportional values are shown in the Table 2 [3].

**Table 2**

Quantification of NPs and MPs in the effluent of tertiary WWTP considering MPs fragmentation and removal throughout the process [3]

Particles	Initial amount of particles <sup>a</sup>	Amount of particles after fragmentation <sup>b</sup>	Amount of particles in the effluent of a tertiary WWTP <sup>c, d</sup>
NPs	0	800	24 – 200
MPs	100	20	0,04 – 2,8
<b>Total</b>	100	820	24,04 – 202,8

<sup>a</sup> Assuming no NPs in the influent

<sup>b</sup> WWTP processes induce the fragmentation of 80% of MPs releasing ten times more NPs

<sup>c</sup> 3 – 25 % of NPs are released to the effluent of a tertiary WWTP

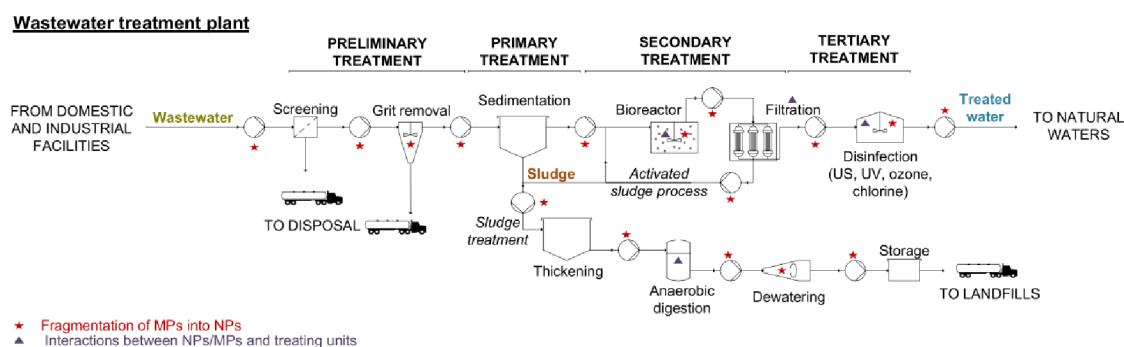
<sup>d</sup> 0,2 – 14 % of MPs are released in the effluent of a tertiary WWTP

Not only shear forces are able to fragment MPs into NPs. By treatment process are presented materials harder than those from which are plastics particles compound. *E.g.*, the hardness of silica bed grains used in rapid sand filtration is 14 GPa while the hardness of PE is one order of magnitude smaller, 0,9 GPa. Hence, mechanism of rapid sand filtration enhances the fragmentation from MPs to NPs. Those observations may result in conclusion, that natural mechanical forces in wild areas are similar to those by water treatment process. MPs thereupon, crumble away and agglomerates of NPs are dispersed. According to DLVO theory, loose patterns formed by NPs are kept apart due to constant turbulent environment during WWTP process and this process therefore facilitate releasing NPs into the water environment [3].

Another study predicate, that one quarter of mass of alumina, silica and carbon nanotubes, which are manufactured as engineered nanomaterials, are contained in secondary/tertiary WWTPs effluents [25].

Furthermore, during wastewater treatment process physical and chemical properties of MPs/NPs can be modified and cause different changes in behaviour among plastic particles and other pollutants present in water. Moreover, surface of microplastics can oxidize. Direct result of oxidation (as caused by organic matter in the activated sludge process of WWTPs) is increasing of roughness and porosity of the microparticle surface, which leads to ten times higher absorption of other pollutants in water, *e.g.*, metal particles. So, the impact on water pollution is significant [3].

The last step of WWT process (Scheme 2) is disinfection which may to a large extent influence breakdown of MPs to NPs [8]. However, exposing PE material to the ozone and chlorine leads to the formation on carbonyl groups on the surface of the plastic particle. Direct consequence is leakage of chlorine-based elements. Hence, disinfection process also changes interactions among NPs/MPs and other entities present in water due to modifications of the particle surface [3].



**Scheme 2** The cycle of WWT process with marked steps, where potential fragmentation of MPs to NPs may occur

In addition, as initial data indicate, most of PE nanoparticles sediment during WWT process and end up in biosolids, sludge and landfills and as a fertilizer. However, when polystyrene particles form hetero-aggregations with other dispersed particles, they do not sediment, but stay on the water surface and significant mass of these nanoparticles is released to the natural surface water [26].

### 3.1 Filtration (Current Trends)

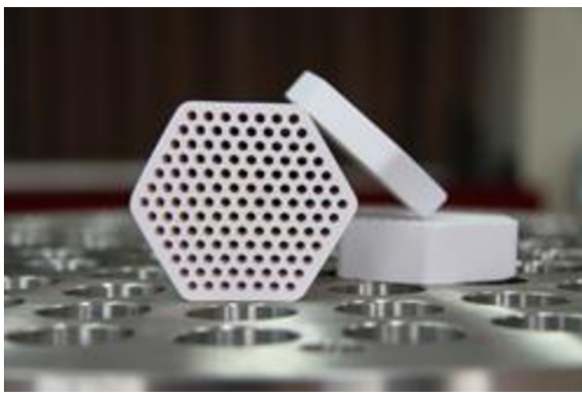
As the above-mentioned shows, MPs and NPs have a great potential to accumulate in organic tissues and to cause various problems in connection with human health. Therefore, it is necessary to filtrate the nano and micro particles during the wastewater treatment process. At present, rapid sand filters are used as a part of WWT process, but as referred to above in this thesis, their effectivity for nanoplastics elimination is not sufficient.

Nowadays, there exist several reliable methods, how to separate these particles, but in our geographical location they are not usually a part of WWT process. This chapter will discuss ultrafiltration and membrane bioreactor.

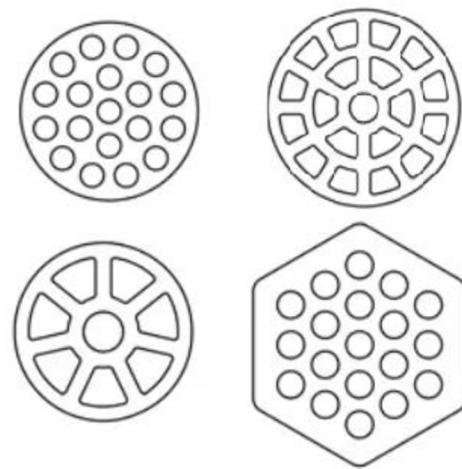
### 3.1.1 Ultrafiltration (UF)

This is a membrane separation process to eliminate mechanical particles from water using nano-sized membrane pores (10-100 nm). Filters used for UF are easy to install and operate at low pressure. To ensure the constant water flux different types of materials (such as ceramics, Figure 3.1) and various types of pores geometry (Figure 3.2) are used to manufacture filters [27].

However, two problems are expected to occur in the process of UF. Mechanical abrasion of filter pores and membrane fouling in connection with creating of “cake layer”<sup>4</sup> are expected as possible complications [3].



**Figure 3.1** Ceramic filter [28]



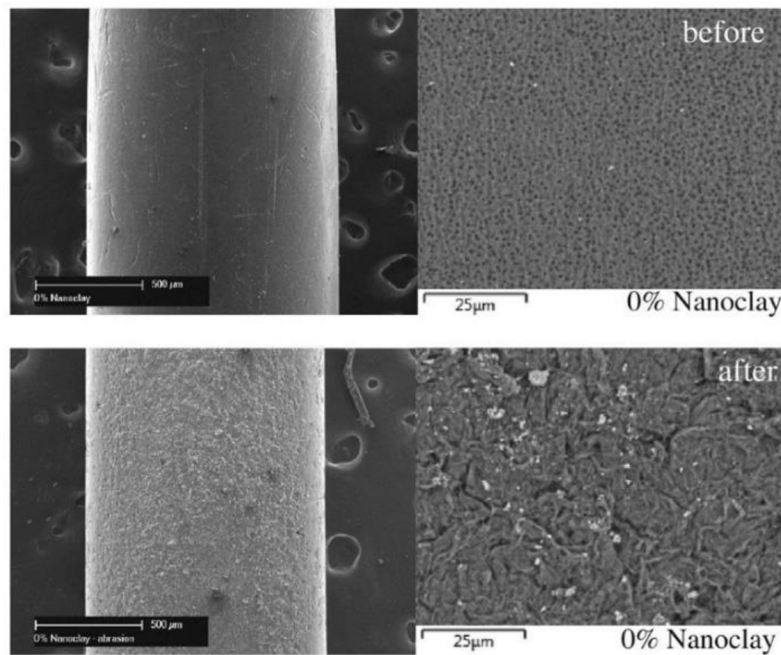
**Figure 3.2** Different types of geometry of ceramic filters [28]

Mechanical properties of a membrane are the key aspects of the membrane resistance to wear. Hence, polymer-based membranes are less resistant than metal based or ceramic membranes. Nonetheless, current trends show that polymer-based membranes are the most widely used in WWTPs such as polyvinylidene difluoride (PVDF). Hardness of a PVDF membrane is generally around 6 MPa, but hardness of HDPE particles is about 900 MPa. Comparison of the two values demonstrates that polymer-based membranes are more likely to incline to wear through abrasion, which cause MPs/NPs in running water as it is shown in the Figure 3.3 [3].

These phenomena indicate enlargement of pores in membrane and UF process will not fulfil its purpose anymore. Moreover, this way of membrane damage may contribute to the global contamination of the aquatic environment by releasing MPs/NPs from WWTPs. In addition, it is necessary to say that there were no studies on MPs/NPs releasing from WWTPs within the context of UF. The correlation between NPs/MPs occurrence in water, their mechanism of formation and their physical and chemical behaviour is obvious, anyway [3].

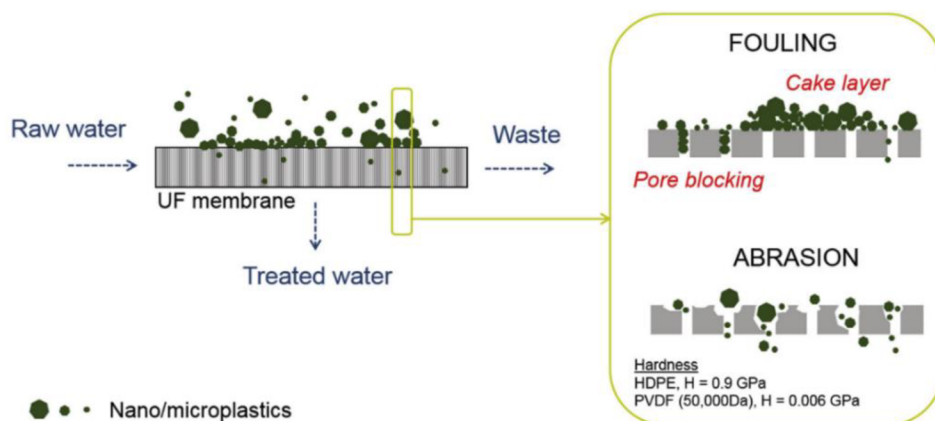
---

<sup>4</sup> Under the term “cake layer” it is meant dense sediment stucked on the membrane pores. This sediment consists of residual waste particles such as *e.g.*, micro or nanoplastics.



**Figure 3.3** SEM images showing the surface of PVDF membrane before and after the abrasion of silicon carbide particles (32-75 μm) [3]

The second major issue of UF is the fouling phenomena. It reduces the water flux through the membrane due to collecting and retaining of particles like NPs/MPs on the membrane surface. The first stage of membrane fouling is pore blocking, when particles larger than pores are caught on membrane surface and partly block the pores. Consequently, cake layer is created as a second stage, which means, that pores are completely blocked by retained particles and membrane filtration performance is to a large extent reduced (Figure 3.4) [3].



**Figure 3.4** Scheme of filtration membrane and its interaction between MPs/NPs [3]

It is estimated that roughness, surface charge and hydrophobicity of micro/nano plastic particles would enhance their interaction with membrane surface. Increasing of transmembrane pressure, longer operation time and higher maintenance costs are directly connected with membrane fouling [3].



Similarly, as to the mechanical abrasion of pores, no reports have been published in connection with membrane fouling, too. However, if UF remains a part of WWTP process, this behaviour of not just plastic particles would become the major issue of continuous WWTPs operation [3].

Therefore, further research is needed in order to obtain more knowledge on potential consequences of NPs/MPs spreading in the environment. It is also must be considered that “microplastics may act as vectors for harmful additives and contaminants and they have the potential to be transferred within the planktonic food web, which might affect the environmental fate of numerous toxic substances” (Lares et al., 2018) [16].

### **3.1.2 Membrane Bioreactor (MBR)**

The second frequent method used for filtration of wastewater is membrane bioreactor. This technology combines biological treatment method (usually activated sludge) and ultrafiltration [29]. One of the advantages of MBR is possibility to turning these two steps into one tank and save space and time during wastewater treatment. Biological step removes undesirable organic materials due to oxidation processes which is provided by active bacteria. Consequently these bacteria get coated by present organic matters and the substances created may be easily caught by UF step [30]. Filtration itself works on the same principle as described before. Typically used sedimentation process is no more necessary because bacteria remove organic matters and ultrafiltration provides mechanical separation of organic and inorganic substances.

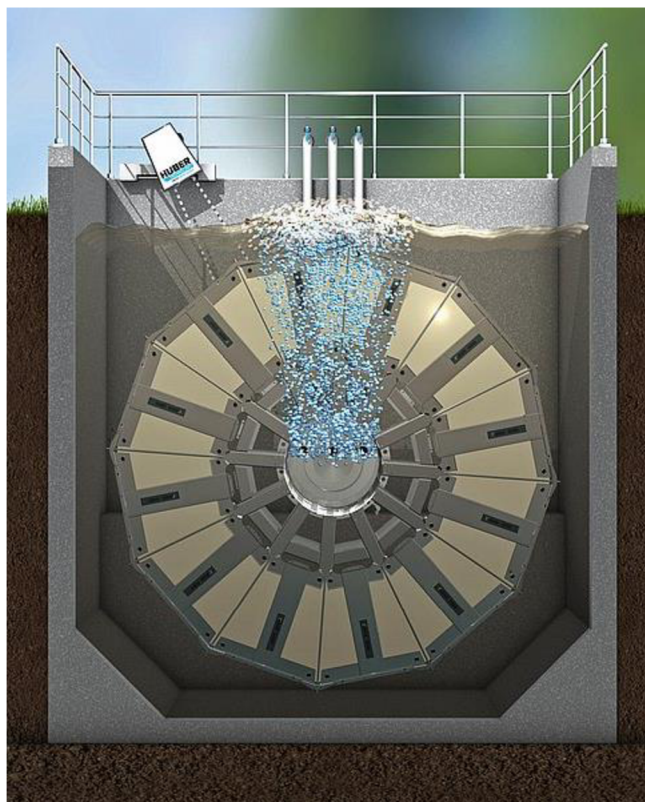
The design solutions depend on each producer, whereas the stress is put on prevent membrane fouling. These phenomena could partly be solved by choosing the proper material for membrane manufacturing. In ideal case, repulsion between negatively charged membranes and nano or microplastic particles (which have negative surface charge by origin) can prevent membrane from fouling [3].

One of the possible design solutions of MBR filtration consists of the PVDF filtration membranes, which are assembled in the row and attached to the construction (Figure 3.5). It works with ultra-low transmembrane pressure which means no pore fouling, just easily removable surface fouling. Water can flow freely into the permeate boxes which is ensured by a membrane with open sides. One unit consists of two modules which enables easier maintenance. The unit is put into tank where wastewater with sludge is driven. In order to prevent the membrane fouling, compressed air is driven under the filtration units and rising air bubbles clear away impurities caught on membrane surface [31].

Another type of MBR filtration is provided in rotating unit with trapezoidal membrane segments (Figure 3.6). Segments are attached to the cylinder which slowly rotate (at 1 rpm) around a centrally placed air distributor which generates powerful cross flow of the air with high turbulences in order to prevent fouling the membrane and formation of covering layers. In comparison with static plate systems, operation requires lower costs, because the aeration can be arranged at half the depth of the tank only and half the scouring air flow is needed (compared to the classic solution, where aeration must be provided from the very bottom of the stationary tank) [32].



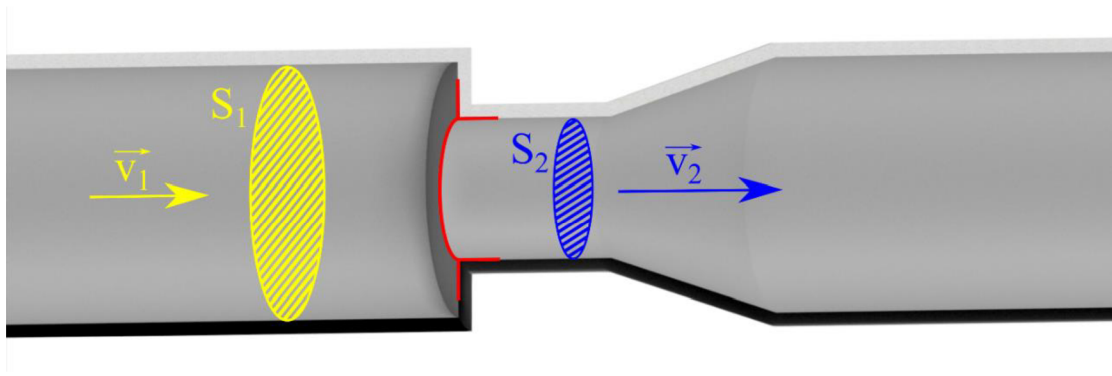
**Figure 3.5** Alfa laval design solution for MBR filtration [31]



**Figure 3.6** HUBER design solution for MBR filtration [32]

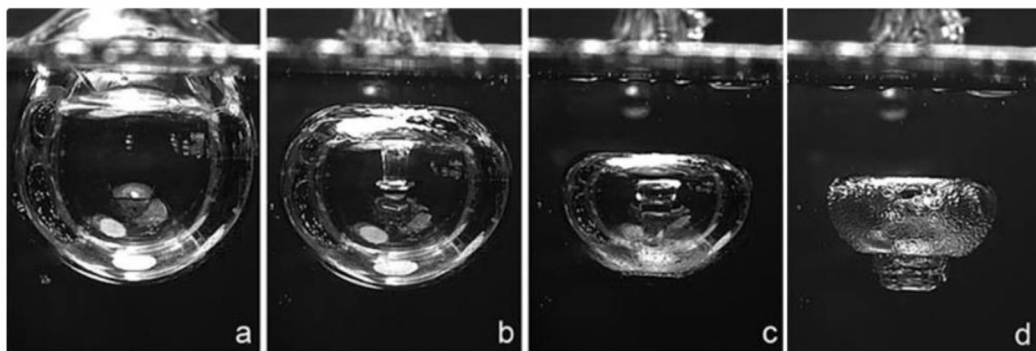
## 4 CAVITATION

Hydrodynamic cavitation is a phenomenon which is linked with turbulent flow in liquids. The main condition in order for cavitation to occur is to lower the water pressure under the vapour pressure at which point the water evaporates. As a direct result, vapour bubbles are formed at the exposed edge. The exposed edge (marked red in the Figure 4.1) is located in the region where wide cross section meets narrow cross section. According to the continuity equation, in the narrow cross section the velocity of water flow is higher than in the wide part. Following from Bernoulli equation static pressure is lower in the narrow section, especially at the exposed edge (Figure 4.1) [33].



**Figure 4.1** Demonstrative pipe (inspired by [33])

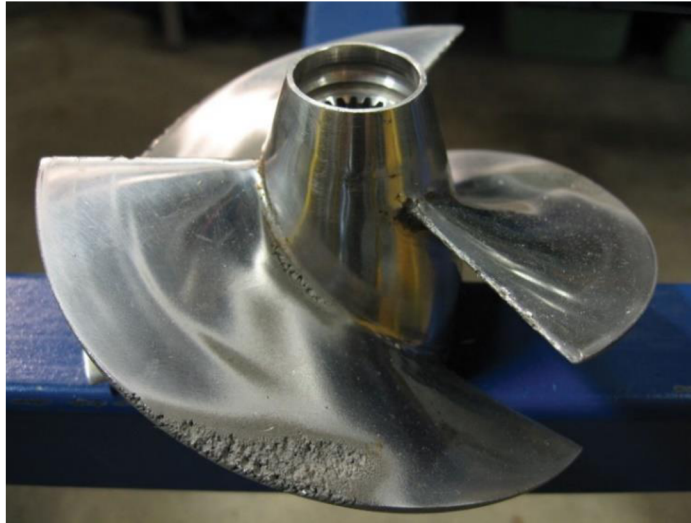
The formed bubbles collapse just as they reach the region with pressure above the vapour pressure. In that moment implosion is initiated and bubble is formed into ring shape, where micro jet occurs as a consequence of pressures putting into balance (Figure 4.2). This process takes about 4 ms. Micro jet then continues to flow in the water and may hit the wall of the container and disturb the integrity of the solid surface [33].



**Figure 4.2** Collapsing of the cavitation bubble and micro jet forming [34]

The consequence of the cavitating liquid is continuous damage to surface by high pressure micro jets, which pit the exposed surface. Hence, cavitation is in general an undesirable effect which occurs by operation of centrifugal pumps, water turbines or marine propellers. The primary consequence is extensive erosion of the rotating blades. This is directly linked with

additional noise, vibrations and lowering efficiency of the device. Furthermore, cavitation activity shortens the life span or may even cause total damage (Figure 4.3) [35].

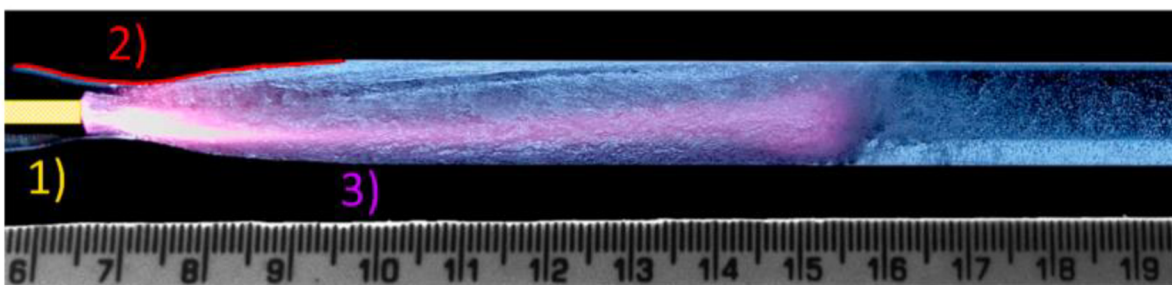


**Figure 4.3** Propeller damaged by cavitation activity [35]

#### 4.1 CaviPlasma [36]

CaviPlasma or hydrodynamic cavitation plasma jet (HCPJ) is a device which combines cavitation phenomenon and plasma<sup>5</sup> discharge. The concurrence of these two phenomena is happening in Venturi nozzle, whereas the shape of the pipe and artificial provoked backpressure ensures cavitation cloud initiation, while the electrodes create the plasma discharge in cavitation bubble (Figure 4.4). To the HCPJ unit, HV (high voltage) generator, vacuum unit, ozonizer and electrical/optical diagnostics are linked (Figure 4.5).

In this thesis it is worked with an original patent of CaviPlasma device (Rudolf, P.; Pochylý, F.; St'ahel, P.; Ráhel', J.; Čech, J.; Maršálek, B. Apparatus for purifying liquids and a method for purifying liquids using this apparatus. Czech Patent No. 308532, 13 December 2019).



**Figure 4.4** A hydrodynamic cavitation plasma jet generated in Venturi nozzle. The placement of the HV electrode (1), the outer shape of Venturi nozzle (2) and cloud of cavitation bubbles and plasma discharge (3) [36]

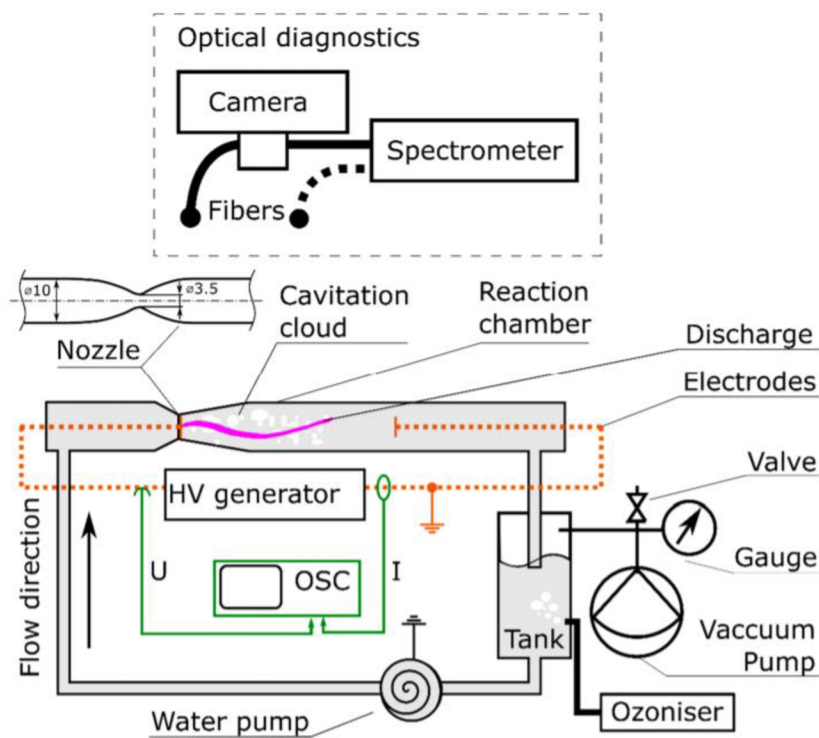
---

<sup>5</sup> Plasma is an ionized gas, which is formed when gas is heated, typically by driving electric current through it. The heating must be sufficient enough to atoms collide with each other and knock their electrons off their orbits in the process. These free electrons then carry electrical current [41].

The formation of cavitation cloud began in the narrowest diameter of Venturi nozzle which corresponds to 3,5 mm. To enlarge the region of cavitation cloud (and so as plasma volume) the backpressure of 40 kPa was used for our experiment provided by a single-stage membrane vacuum pump. The value of backpressure was regulated by gas-tight ball valve and measured with a gas pressure gauge.

Plasma discharge with frequency of 65 kHz was provoked between two electrodes placed in a reaction chamber. The measured value of constant power input of HV generator was 400 W. The 4 mm in diameter electrodes were made of insulated copper wire and were submerged coaxially into the water flux. The direct contact with liquid was operated only at the end surface of the wire. The grounded electrode was positioned behind the cavitation cloud region, approx. 160 mm away from the HV electrode.

By these options, closed-loop circuit enables volumetric flow rate about 0,55 m<sup>3</sup>/h by total volume of water tank approx. 2 l.



**Figure 4.5** The scheme of experimental setup of HCPJ unit [36]

## 5 EXPERIMENT

There exists a prediction that micro or nanoplastic particles may be destructed by using CaviPlasma device. This idea was experimentally verified thanks to doc. Šťáhel from Department of Physical Electronics, CEPLANT.

### 5.1 Description of the Experiment

For the experiment were used polyamide seeding particles (PSP), specifically made of polyamide 12 (PA12). The polyamide (PA), as a polymer material, consists of recurring amide ( $R-CO-NH-R'$ ) groups which are integral parts of the main polymer chain [37]. The used particles were of 20  $\mu m$  [38] and 5  $\mu m$  [39] in diameter<sup>6</sup>. These particles are products of the company DANTEC DYNAMIC and were chosen as a recommended particles for water flow applications. The shape of PSP is round but not exactly spherical, because their production is provided by polymerisation processes [40].

The experimental procedure was as following. At the beginning was 3 g PSP powder moistened in order to prevent clinging of those particles on the inner surface of the Venturi nozzle. Consequently, these moistened particles were put into the 2 l of water and were stirred. The suspension of microplastics and water then entered the CaviPlasma device.

The first stage of the experiment was provided when only cavitation mode was activated in the CaviPlasma and suspension was exposed to this environment for 3 minutes. After finishing the first stage, samples were taken. The remaining suspension of water and PSP was subsequently exposed for another 3 minutes to the cavitating liquid where also a plasma discharge was present as a second stage. The whole procedure was carried out with 5  $\mu m$  particles as well as with 20  $\mu m$  microplastics.

It was expected, that microplastic particle enters the cavitation bubble and by affection of the plasma discharge will be gradually burned out and so destruction thereof will be provided. The PSP sample was exposed to the cavitation and plasma discharge periodically during the whole experiment.

Consequently, after the experiment itself, a sample of each tested liquid volume contaminated by PSP was taken. These samples were covered by C-Si substrate and scanned by scanning electron microscope (SEM).

### 5.2 Results

From the scans obtained by SEM, no changes were visually noticed between single PSP, which were treated only by cavitation compared to the other ones which were moreover affected by plasma discharge. The shape of both, 20  $\mu m$  (Figure 5.1 and Figure 5.2) as well as 5  $\mu m$  (Figure 5.3 and Figure 5.4), particles remain spherical without any remarkable surface damage.

---

<sup>6</sup> For the purposes of this bachelor thesis there was shown no possibility to obtain nano-sized plastic particles. This was also influenced by the current covid situation and lack of available sources of laboratory particles samples. Under these circumstances it was decided to use micro-sized plastic particles, which were available and which were used as a replacement for nanoplastic particles for primary experiment.

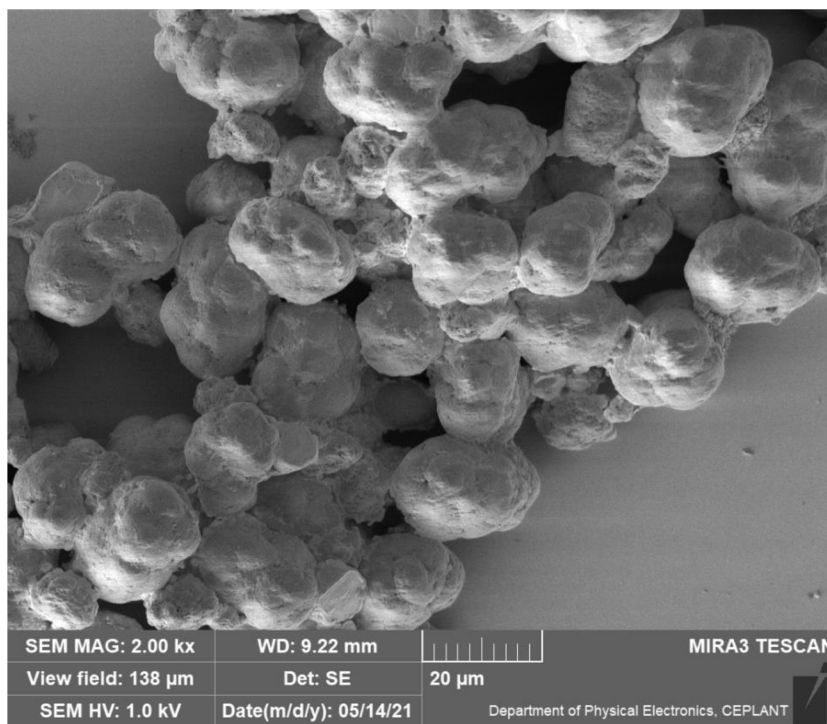


Figure 5.1 PSP of 20  $\mu$ m in size after being exposed to cavitation mode

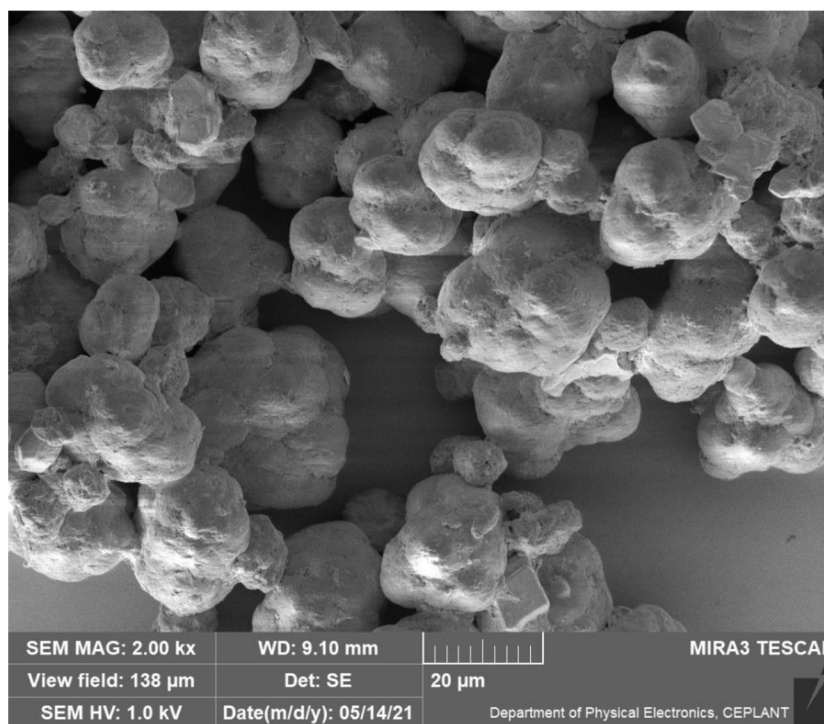
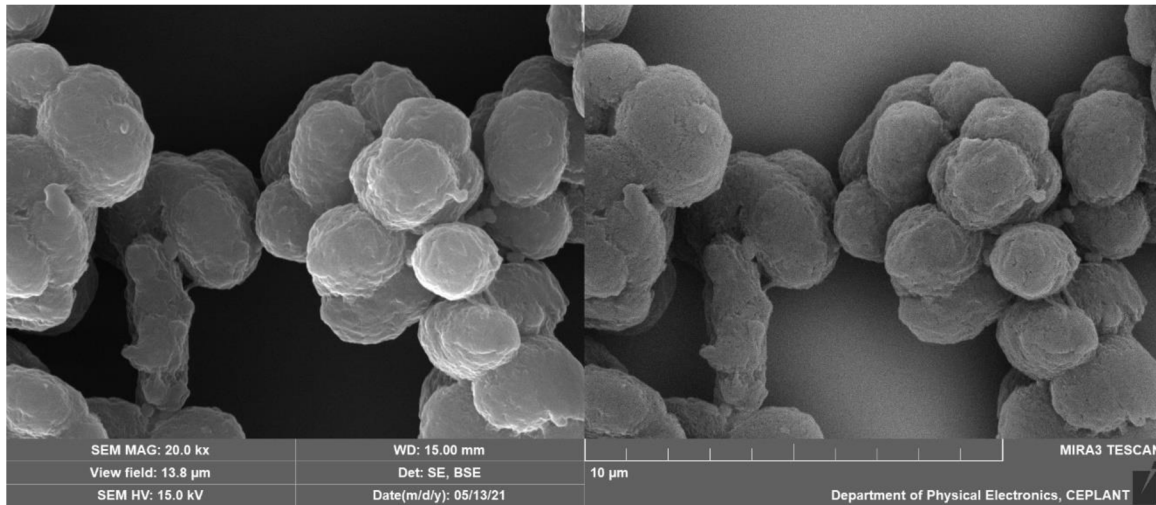
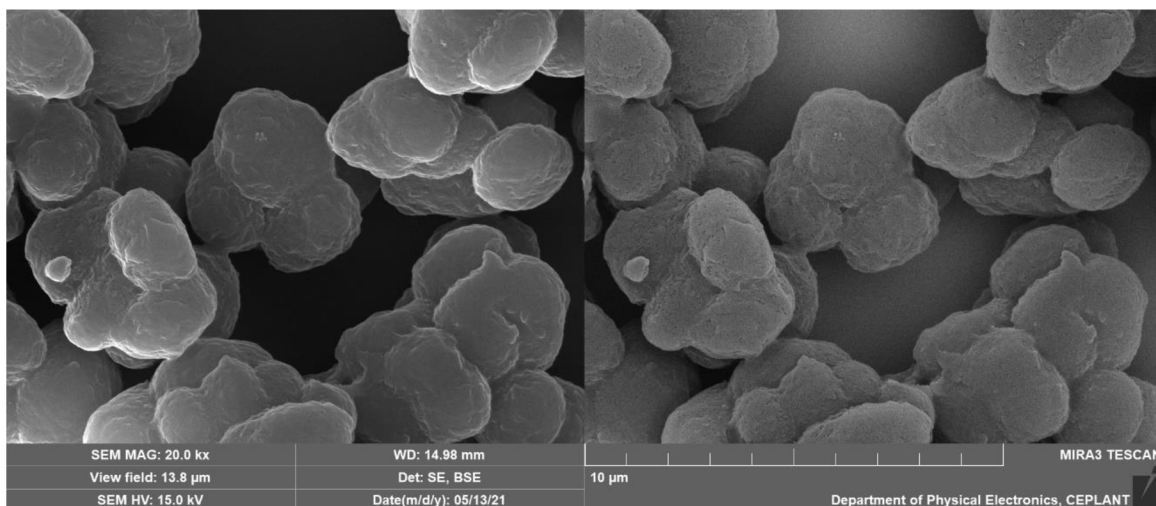


Figure 5.2 PSP of 20  $\mu$ m in size after being exposed to cavitating liquid including plasma discharge application



**Figure 5.3** PSP of 5 μm in size after being exposed to cavitation mode

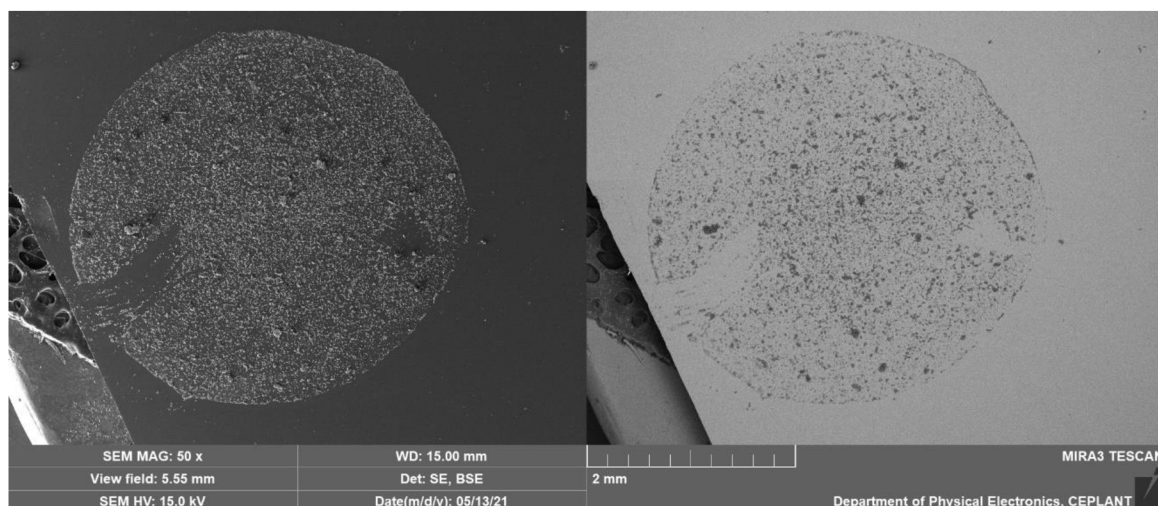


**Figure 5.4** PSP of 5 μm in size after being exposed to cavitating liquid including plasma discharge application

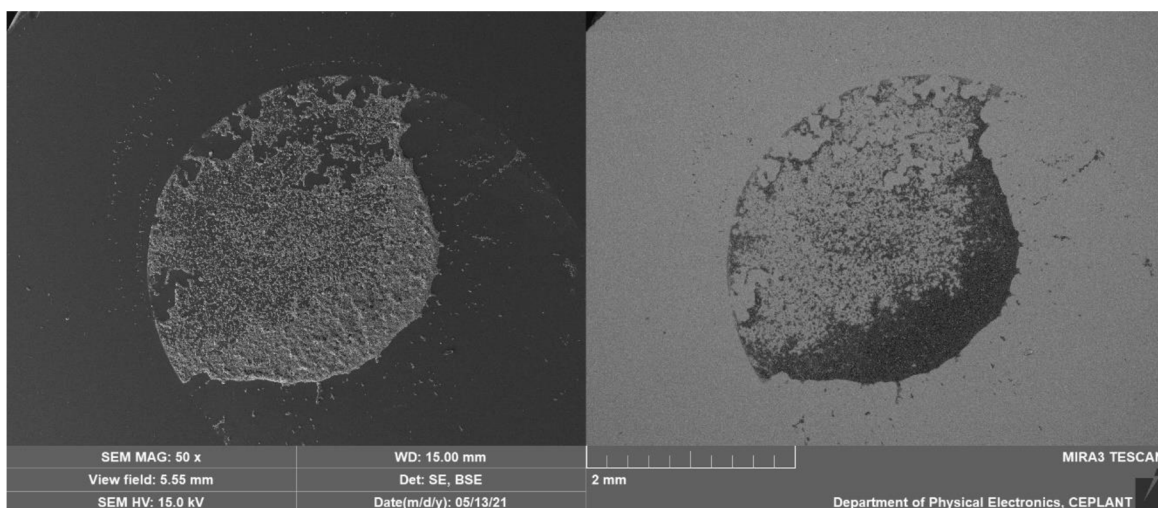
However, the scans also display that PSP affected by plasma discharge show higher tendency to agglomerate in comparison to the microplastics treated only by cavitation. This phenomenon is obvious by observing 5 μm microparticles. In the Figure 5.5 are PSP distributed quite evenly while in the Figure 5.6 the PSP affected by plasma discharge are agglomerated in thicker and nonproportional layer compared to the previous figure.

This phenomenon may be also noticeable in the Figure 5.8 where microplastic particles are grouped together and form continuous structures. Some kind of agglomerate is also present in the Figure 5.7, however, that may be result of natural tendency of PA12 particles sticking together, not the result of cavitation effect. Nonetheless, the rest of microplastics in the Figure 5.7 form loose pattern.

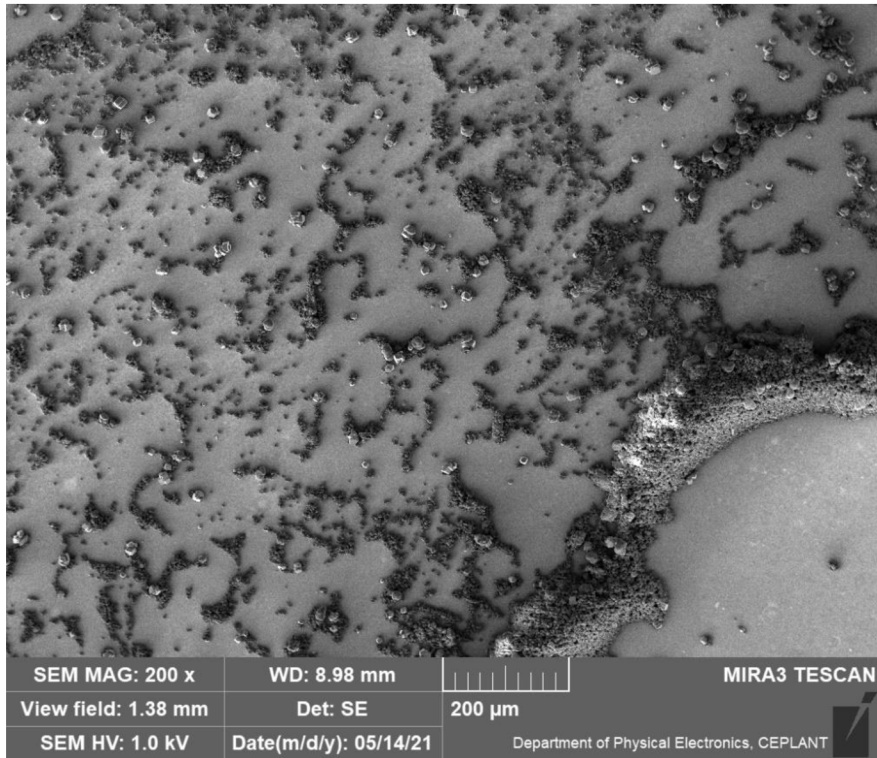




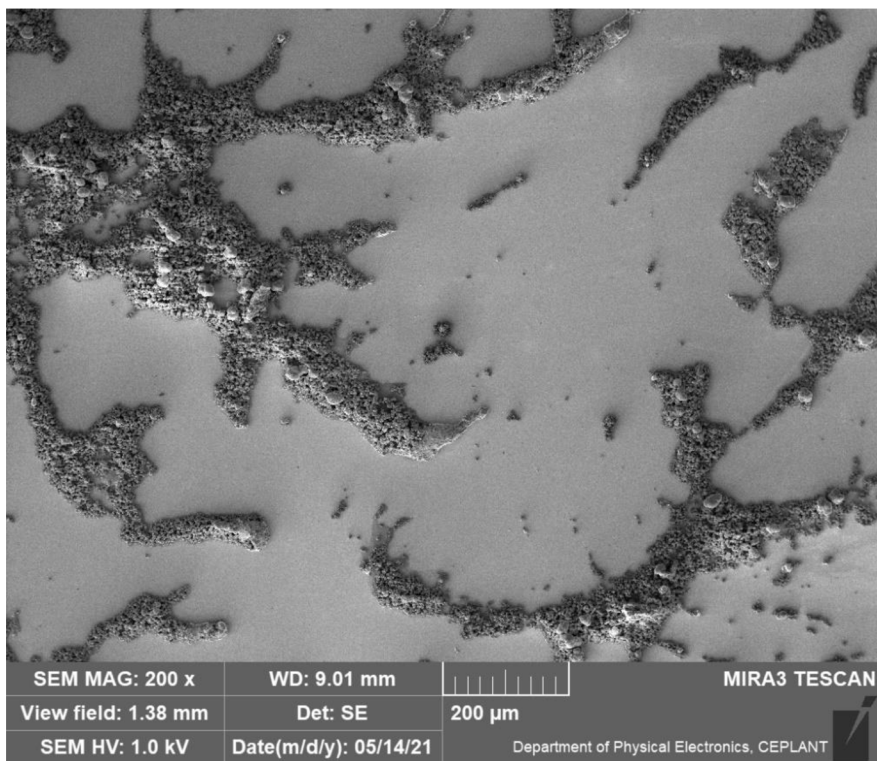
**Figure 5.5** A single drop of PSP of 5 μm in size after being exposed to cavitation mode



**Figure 5.6** A single drop of PSP of 5 μm in size after being exposed to cavitating liquid including plasma discharge application



**Figure 5.7** The detail of PSP of 5 µm in size after being exposed to cavitation mode without specific tendency to agglomerate



**Figure 5.8** The detail of PSP of 5 µm in size after being exposed to cavitating liquid including plasma discharge application. The microplastics agglomeration is obvious by this time.

## DISCUSSION

The original assumption (that plastic particles will be eliminated by using CaviPlasma device) was not confirmed by the experiment. This may be caused by various factors. The first may be, that micro instead of nanoplastics for the experiment were used. The point is microplastics not being small enough for that kind of application, which means there was no sufficient energy provided by plasma discharge to even lessen their volume. However, using nanoplastic particles for this experiment may show different results because energy generated by plasma discharge may be enough to cause damage thereof. Hence, further experiment needs to be performed to ensure a validity of this thought.

The used kind of plastics used is considered to be the second influencing factor. Trying different kinds of plastic materials may influence the final result of the experiment because the plastic types slightly differ in density and melting point.

Otherwise, time for the experiment was relatively long, when considering the idea of CaviPlasma application as a part of WWT process. In this case PSP were exposed to the CaviPlasma environment for 3 minutes. The volumetric flow rate of CaviPlasma is about 0,55 m<sup>3</sup>/h by total volume of the tank 2 l. This means, that PSP met the cavitation area approx. 14 times during the process. Therefore, the extension of the exposing time may not be efficient solution.

However, it is worth to give a sight to the observation of microparticles agglomeration after plasma discharge application. There is a question if the agglomeration is favourable phenomenon or not. It may be assumed, that agglomerated microparticles are easier to catch and then easier to remove. Thus, such formation of continuous structures may contribute to easier elimination of micro or perhaps nanoplastics from wastewater. However, further experiment is needed to be done in order to explore the whole potential of CaviPlasma device in the context of micro or nanoplastics elimination.

## CONCLUSION

In this thesis there was the problematics of nano and microplastic pollution discussed. This paper provides that plastic pollution is ubiquitous, thus, micro and nanoplastic particles had become a part of everyday human life. They are present in water, soil and organic tissues as well. Recent studies focus on the occurrence of micro and nanoplastic particles in human organism and potential problems caused by this type of pollution are considered, too. This thesis also describes mechanism of microplastics fragmentation to the nanoplastic and consequently the behaviour and interactions of released particles in the water.

As it was reflected, great contributors to the global micro and nanoplastic pollution are wastewater treatment plants. However, the releasing of MPs or NPs does not run just by one mechanism, the problem is complex. But as a fact remains, that it is possible to reduce amount of released plastics particles by controlling the last steps of the treatment. One of the potential solutions may be CaviPlasma device.

The effect of the CaviPlasma device was experimentally tested on the microplastic particles. Specifically, polyamide 12 particles of round shape were used. The main idea, that microplastic particle enters the cavitation bubble and will be disrupted by plasma discharge, was not verified. The possibilities why it did not work as it was expected were previously discussed. On the other hand, after the 5 µm particles exposition to cavitating liquid including plasma discharge application, microplastics show higher rate of aggregation compared to the mode when only cavitation was applied. It is not clear yet why such interaction occurs and according which mechanism it runs by.

Nonetheless, agglomeration of microplastics after the CaviPlasma treatment may be the subject of further research. It would be also worth to scrutinise the effect of CaviPlasma on the nanoplastic particles.

## REFERENCES

- [1] IQBAL, Shahid, Jianchu XU, Schaefer Douglas ALLEN, Sehroon KHAN, Sadia NADIR, Muhammad Saleem ARIF and Tahira YASMEEN. *Unraveling consequences of soil micro- and nano-plastic pollution on soil-plant system: Implications for nitrogen (N) cycling and soil microbial activity* [online]. B.m.: Elsevier Ltd. 1. December 2020 [accessed. 2020-09-24]. ISSN 18791298. Available at: doi:10.1016/j.chemosphere.2020.127578
- [2] GUNAALAN, Kuddithamby, Elena FABBRI and Marco CAPOLUPO. The hidden threat of plastic leachates: A critical review on their impacts on aquatic organisms. *Water Research* [online]. 2020, 184, 116170 [accessed. 2020-09-21]. ISSN 18792448. Available at: doi:10.1016/j.watres.2020.116170
- [3] ENFRIN, Marie, Ludovic F. DUMÉE and Judy LEE. *Nano/microplastics in water and wastewater treatment processes – Origin, impact and potential solutions* [online]. B.m.: Elsevier Ltd. 15. September 2019 [accessed. 2020-09-26]. ISSN 18792448. Available at: doi:10.1016/j.watres.2019.06.049
- [4] TRIEBSKORN, Rita, Thomas BRAUNBECK, Tamara GRUMMT, Lisa HANSLIK, Sven HUPPERTSBERG, Martin JEKEL, Thomas P. KNEPPER, Stefanie KRAIS, Yanina K. MÜLLER, Marco PITTROFF, Aki S. RUHL, Hannah SCHMIEG, Christoph SCHÜR, Claudia STROBEL, Martin WAGNER, Nicole ZUMBÜLTE and Heinz R. KÖHLER. *Relevance of nano- and microplastics for freshwater ecosystems: A critical review* [online]. B.m.: Elsevier B.V. 1. January 2019 [accessed. 2020-09-26]. ISSN 18793142. Available at: doi:10.1016/j.trac.2018.11.023
- [5] SUN, Hongyan, Ruyuan JIAO and Dongsheng WANG. The difference of aggregation mechanism between microplastics and nanoplastics: Role of Brownian motion and structural layer force. *Environmental Pollution* [online]. 2021, 268 [accessed. 2021-02-24]. ISSN 18736424. Available at: doi:10.1016/j.envpol.2020.115942
- [6] RIBEIRO, Francisca, Jake W. O'BRIEN, Tamara GALLOWAY and Kevin V. THOMAS. *Accumulation and fate of nano- and micro-plastics and associated contaminants in organisms* [online]. B.m.: Elsevier B.V. 1. February 2019 [accessed. 2020-09-11]. ISSN 18793142. Available at: doi:10.1016/j.trac.2018.12.010
- [7] HERNANDEZ, Laura M, Elvis Genbo XU, Hans C E LARSSON, Rui TAHARA, Vimal B MAISURIA and Nathalie TUFENKJI. Plastic Teabags Release Billions of Microparticles and Nanoparticles into Tea [online]. 2019 [accessed. 2020-11-04]. Available at: doi:10.1021/acs.est.9b02540
- [8] CHENG, Yan Laam, Jong Gook KIM, Hye Bin KIM, Jeong Hwan CHOI, Yiu FAI TSANG and Kitae BAEK. Occurrence and removal of microplastics in wastewater treatment plants and drinking water purification facilities: A review. *Chemical Engineering Journal* [online]. 2021, 410 [accessed. 2021-04-29]. ISSN 13858947. Available at: doi:10.1016/j.cej.2020.128381
- [9] PAUL, Maxi B., Valerie STOCK, Julia CARA-CARMONA, Elisa LISICKI, Sofiya SHOPOVA, Valérie FESSARD, Albert BRAEUNING, Holger SIEG and Linda BÖHMERT. *Micro- And nanoplastics-current state of knowledge with the focus on oral uptake and toxicity* [online]. B.m.: Royal Society of Chemistry. 1. October 2020 [accessed. 2021-03-01]. ISSN 25160230. Available at: doi:10.1039/d0na00539h
- [10] ANDRADY, Anthony L. *Microplastics in the marine environment* [online]. August 2011. ISSN 0025326X. Available at: doi:10.1016/j.marpolbul.2011.05.030
- [11] CAI, Liqi, Jundong WANG, Jinping PENG, Ziqing WU and Xiangling TAN. Observation of the degradation of three types of plastic pellets exposed to UV

- irradiation in three different environments. *Science of the Total Environment* [online]. 2018, 628–629, 740–747 [accessed. 2021-04-30]. ISSN 18791026. Available at: doi:10.1016/j.scitotenv.2018.02.079
- [12] *Fractography in Failure Analysis of Polymers - Michael Hayes, Dale Edwards, Andy Shah - Google Knihy* [online]. [accessed. 2021-04-30]. Available at: [https://books.google.cz/books?hl=sk&lr=&id=7dnEAgAAQBAJ&oi=fnd&pg=PP1&dq=fractography+in+failure+analysis+of+polymers&ots=FjQAYvb8fW&sig=M\\_gUDm6gfsOL0Nowp293\\_5Ii4HA&redir\\_esc=y#v=onepage&q&f=false](https://books.google.cz/books?hl=sk&lr=&id=7dnEAgAAQBAJ&oi=fnd&pg=PP1&dq=fractography+in+failure+analysis+of+polymers&ots=FjQAYvb8fW&sig=M_gUDm6gfsOL0Nowp293_5Ii4HA&redir_esc=y#v=onepage&q&f=false)
- [13] DRESDEN, Max. Boltzmann constant. *Access Science* [online]. 2020 [accessed. 2021-02-24]. Available at: doi:10.1036/1097-8542.089800
- [14] SUMMERS, Stephen, Theodore HENRY and Tony GUTIERREZ. Agglomeration of nano- and microplastic particles in seawater by autochthonous and de novo-produced sources of exopolymeric substances. *Marine Pollution Bulletin* [online]. 2018, 130, 258–267. ISSN 18793363. Available at: doi:10.1016/j.marpolbul.2018.03.039
- [15] CLOGSTON, Jeffrey D. and Anil K. PATRI. Zeta potential measurement. *Methods in molecular biology (Clifton, N.J.)* [online]. 2011, 697, 63–70 [accessed. 2021-05-18]. ISSN 19406029. Available at: doi:10.1007/978-1-60327-198-1\_6
- [16] LARES, Mirka, Mohamed Chaker NCIBI, Markus SILLANPÄÄ and Mika SILLANPÄÄ. Occurrence, identification and removal of microplastic particles and fibers in conventional activated sludge process and advanced MBR technology. *Water Research* [online]. 2018, 133, 236–246 [accessed. 2021-02-09]. ISSN 18792448. Available at: doi:10.1016/j.watres.2018.01.049
- [17] SPAIN, Anne M., Lee R. KRUMHOLZ and Mostafa S. ELSHAHED. Abundance, composition, diversity and novelty of soil Proteobacteria. *ISME Journal* [online]. 2009, 3(8), 992–1000. ISSN 17517362. Available at: doi:10.1038/ismej.2009.43
- [18] ARAUJO, Ricardo, Vadakattu V.S.R. GUPTA, Frank REITH, Andrew BISSETT, Pauline MELE and Christopher M.M. FRANCO. Biogeography and emerging significance of Actinobacteria in Australia and Northern Antarctica soils. *Soil Biology and Biochemistry* [online]. 2020, 146, 107805 [accessed. 2020-11-04]. ISSN 00380717. Available at: doi:10.1016/j.soilbio.2020.107805
- [19] GALLOWAY, Tamara S. Micro- and nano-plastics and human health. In: *Marine Anthropogenic Litter* [online]. B.m.: Springer International Publishing, 2015 [accessed. 2020-10-08], p. 343–366. ISBN 9783319165103. Available at: doi:10.1007/978-3-319-16510-3\_13
- [20] CHAE, Yooeun, Dasom KIM, Mi Jung CHOI, Youngjae CHO and Youn Joo AN. Impact of nano-sized plastic on the nutritional value and gut microbiota of whiteleg shrimp *Litopenaeus vannamei* via dietary exposure. *Environment International* [online]. 2019, 130 [accessed. 2020-09-21]. ISSN 18736750. Available at: doi:10.1016/j.envint.2019.05.042
- [21] RAGUSA, Antonio, Alessandro SVELATO, Criselda SANTACROCE, Piera CATALANO, Valentina NOTARSTEFANO, Oliana CARNEVALI, Fabrizio PAPA, Mauro Ciro Antonio RONGIOLETTI, Federico BAIOTTO, Simonetta DRAGHI, Elisabetta D'AMORE, Denise RINALDO, Maria MATTA and Elisabetta GIORGINI. *Plasticenta: First evidence of microplastics in human placenta* [online]. B.m.: Elsevier Ltd. 1. January 2021 [accessed. 2021-04-07]. ISSN 18736750. Available at: doi:10.1016/j.envint.2020.106274
- [22] LI, Dunzhu, Yunhong SHI, Luming YANG, Liwen XIAO, Daniel K. KEHOE, Yurii K. GUN'KO, John J. BOLAND and Jing Jing WANG. Microplastic release from the degradation of polypropylene feeding bottles during infant formula preparation. *Nature*

- Food* [online]. 2020 [accessed. 2020-11-04]. ISSN 2662-1355. Available at: doi:10.1038/s43016-020-00171-y
- [23] WINKLER, Anna, Nadia SANTO, Marco Aldo ORTENZI, Elisa BOLZONI, Renato BACCHETTA and Paolo TREMOLADA. Does mechanical stress cause microplastic release from plastic water bottles? *Water Research* [online]. 2019, 166 [accessed. 2021-01-17]. ISSN 18792448. Available at: doi:10.1016/j.watres.2019.115082
- [24] COX, Kieran D, Garth A COVERNTON, Hailey L DAVIES, John F DOWER, Francis JUANES and Sarah E DUDAS. Human Consumption of Microplastics [online]. 2019. Available at: doi:10.1021/acs.est.9b01517
- [25] KELLER, Arturo A and Anastasiya LAZAREVA. Predicted Releases of Engineered Nanomaterials: From Global to Regional to Local. *Environ. Sci. Technol. Lett* [online]. 2014, 1 [accessed. 2021-05-18]. Available at: doi:10.1021/ez400106t
- [26] *Aggregation and stability of nanoscale plastics in aquatic environment* | Elsevier Enhanced Reader [online]. [accessed. 2020-10-08]. Available at: <https://reader.elsevier.com/reader/sd/pii/S0043135419311753?token=4A779066099DB9E1AFC02F6A61F0646B733E85890E72C9DF4873FA848E0E5E37C85FD86DE3B571F19F3EE22CBBB7438B>
- [27] *PVDF UF Membrane (NM-UF-225)* | Ultrafiltration Membrane - Hinada [online]. [accessed. 2021-02-11]. Available at: <https://www.hinada.com/product/pvdf-uf-membrane-nm-uf-225/>
- [28] *Ceramic Membrane - ultrafiltration membrane* [online]. [accessed. 2021-02-12]. Available at: <https://www.kaimimembrane.com/Ceramic-Membrane.html#jkBqrKoiJrmjrinknni>
- [29] *MBR Membrane Bioreactor For Wastewater Treatment* [online]. [accessed. 2021-02-22]. Available at: <https://www.hinada.com/products/mbr-membrane-bioreactor/>
- [30] *HUBER řešení pro membránové bioreaktory - Huber Czech Republic* [online]. [accessed. 2021-02-22]. Available at: <https://www.huber.cz/cz/reseni/zarizeni-pro-zpracovani-splasku/membranovy-aktivacni-kalovy-proces.html>
- [31] *Alfa Laval - MBR Membranes* [online]. [accessed. 2021-02-22]. Available at: <https://www.alfalaval.com/products/separation/membranes/mbr-membranes/mbr-membranes/>
- [32] *HUBER Membrane Filtration VRM® - Huber Technology Inc.* [online]. [accessed. 2021-02-22]. Available at: <https://www.huber-technology.com/produkte/membranfiltration-mbr/huber-membranfiltration-vrmmr.html>
- [33] *Cavitation - Easily explained!* - YouTube [online]. [accessed. 2021-03-02]. Available at: <https://www.youtube.com/watch?v=U-uUYCFDTrc>
- [34] *Hydrodynamic cavitation and its application in the fuel industry - GlobeCore* [online]. [accessed. 2021-03-03]. Available at: <https://globecore.co.za/hydrodynamic-cavitation-and-its-application-in-the-fuel-industry/>
- [35] *Cavitation* | physics | *Britannica* [online]. [accessed. 2021-03-03]. Available at: <https://www.britannica.com/science/cavitation>
- [36] ČECH, Jan, Pavel ŠTAHEL, Jozef RÁHEL, Lubomír PROKEŠ, Pavel RUDOLF, Eliška MARŠÁLKOVÁ and Blahoslav MARŠÁLEK. Mass production of plasma activated water: Case studies of its biocidal effect on algae and cyanobacteria. *Water (Switzerland)* [online]. 2020, 12(11), 1–18. ISSN 20734441. Available at: doi:10.3390/w12113167
- [37] *Polyamide - an overview* | *ScienceDirect Topics* [online]. [accessed. 2021-05-17]. Available at: <https://www.sciencedirect.com/topics/materials-science/polyamide>

- [38] *PSP-20, diam. 20  $\mu\text{m}$ , 250 g - Dantec Dynamics | Precision Measurement Systems & Sensors* [online]. [accessed. 2021-05-16]. Available at: <https://www.dantecdynamics.com/product/psp-20-diam-20-m-250-g/>
- [39] *PSP-5, diam. 5  $\mu\text{m}$ , 250 g - Dantec Dynamics | Precision Measurement Systems & Sensors* [online]. [accessed. 2021-05-16]. Available at: <https://www.dantecdynamics.com/product/psp-5-diam-5-m-250-g/>
- [40] *Seeding Materials - Dantec Dynamics | Precision Measurement Systems & Sensors* [online]. [accessed. 2021-05-16]. Available at: <https://www.dantecdynamics.com/components/seeding-materials/>
- [41] *Introduction to Plasma Physics - R.J Goldston - Google Knihy* [online]. [accessed. 2021-04-30]. Available at: [https://books.google.cz/books?id=7kM7yEFUGnAC&q=chen+%22introduction+to+plasma+physics%22&redir\\_esc=y#v=onepage&q=chen+%22introduction+to+plasma+physics%22&f=false](https://books.google.cz/books?id=7kM7yEFUGnAC&q=chen+%22introduction+to+plasma+physics%22&redir_esc=y#v=onepage&q=chen+%22introduction+to+plasma+physics%22&f=false)



## LIST OF ABBREVIATIONS

<b>Abbreviation</b>	<b>Meaning</b>
BPA	bisphenol A
BRFs	brominated flame retardants
DLVO	Derjaguin, Landau, Verwey, Overbeek
EPA	eicosapentaenoic acid
EPS	exopolymeric substances
HCPJ	hydrodynamic cavitation plasma jet
HDPE	high density polyethylene
HV	high voltage
MPs	microplastics
NPs	nanoplastics
PA	polyamide
PA12	polyamide 12
PE	polyethylene
PET	polyvinyl chloride
PP	polypropylene
PP-IFBs	polypropylene infant feeding bottles
PS	polystyrene
PSP	polyamide seeding particles
PVC	polyethylene terephthalate
PVDF	polyvinylidene difluoride
SEM	scanning electron microscope
UF	ultrafiltration
UV	ultraviolet
WWT	wastewater treatment
WWTPs	wastewater treatment plants