

***Příloha VII. – MAN Truck & Bus AG - Power Gas engines for CHP units and gensets [13]***



# Power

Gas engines for CHP units and gensets

**MAN Engines**

A Division of MAN Truck & Bus





# Contents

Gas engines for cogenerating power stations . . . . .	3
Application type and product range . . . . .	3
Servicing concept . . . . .	3
<b>Description of engines</b>	
E0834 . . . . .	4
E0836 . . . . .	6
E2876 . . . . .	8
E2676 . . . . .	10
E2848 . . . . .	12
E2842 . . . . .	14
E3262 . . . . .	16



# Gas engines for cogenerating power stations

## Efficient electricity and heat generation

Manufacturers and operators of CHP applications have strong requirements. Robust, compact engines have to work reliably 24 hours a day, 7 days per week. Economic operation over the life cycle of the entire plant is therefore essential. This requires a high level of efficiency by maximum utilisation of primary energy and low plant operating costs. With their continuous development programme, MAN engines always make a contribution to greater efficiency. Reliable and low in emissions.

## Application type and product range

### Description of engines

Mode of operation		COP with natural gas		COP with special gas	
at engine speed	rpm (Hz)	1 500 (50)	1 800 (60)	1 500 (50)	1 800 (60)
Type	Cylinders	Power (kW) <sup>1)</sup>			
E0834	4	37–68	45–68	68	68
E0836	6	56–110	64–110	110	110
E2676	6	220	250	220	250
E2876	6	150–220	170–210	130–220	130–200
E2848	8	265	295	265	295
E2842	12	250–420	280–400	420	420
E3262	12	550	580	550	580

1) in accordance with German Industrial Standard DIN ISO 3046, Part 1

## Servicing concept

MAN offers power-unit manufacturers a tailor-made servicing concept. This is how MAN gives you the option of performing servicing for your end customers yourself, from start to finish. This is made possible by an extensive training offering which can be matched individually to your needs.

### Customer Benefits

- High power and maximum efficiency
- Low operating costs as a result of low levels of lubricant and fuel consumption as well as extended service intervals
- Low emissions due to state-of-the-art combustion technologies
- Low space requirement due to compact design
- Reliable in use thanks to field-tested technology
- Long service life resulting from application-specific design

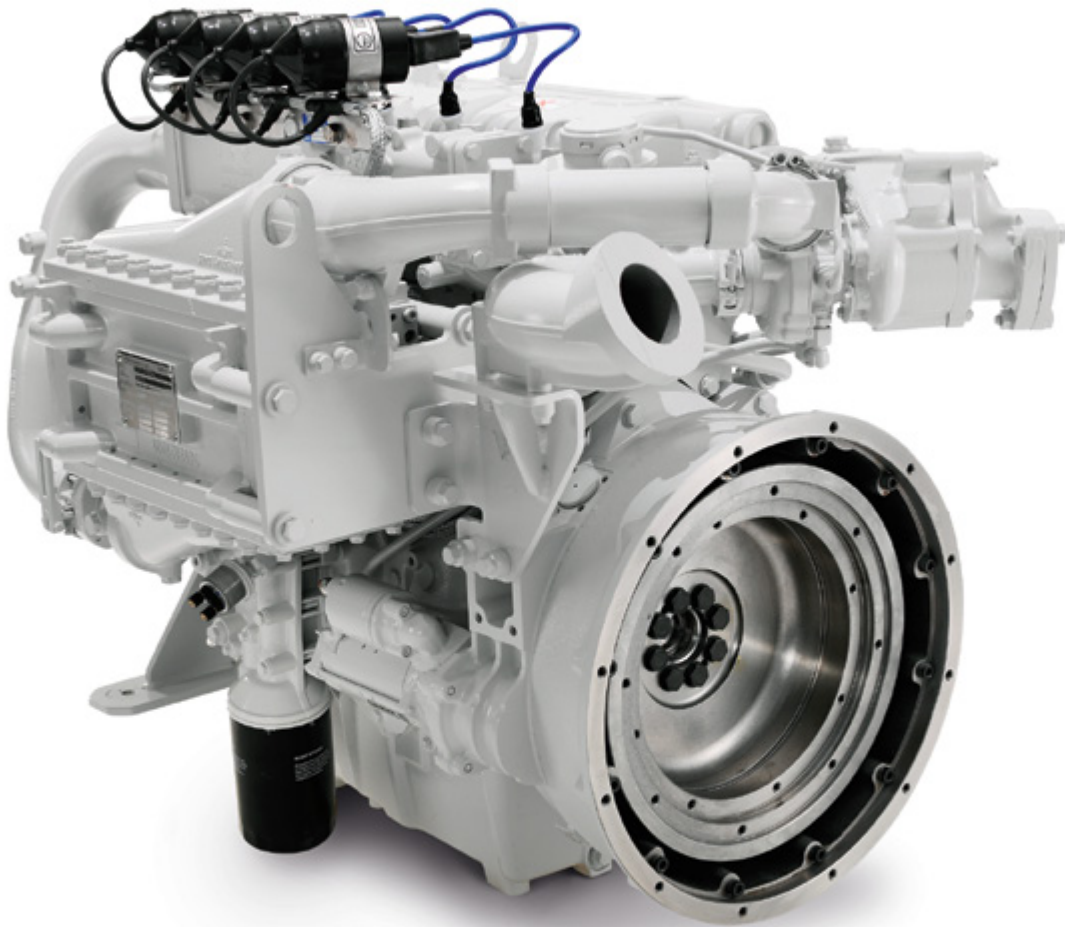

## E0834

### Description of engines

#### Characteristics E0834 E

- Cylinders and arrangement: 4 cylinders in-line
- Mode of operation: four-stroke spark-ignition gas engine
- Engine cooling: water-cooled
- Exhaust system: water-cooled exhaust pipe

#### Characteristics E0834 LE

- Cylinders and arrangement: 4 cylinders in-line
- Mode of operation: four-stroke spark-ignition gas engine
- Turbocharging: turbo charger with pressure-oil lubricated bearings and water-cooled bearing pedestal
- Engine cooling: water-cooled
- Air-fuel mixture cooling: two-stage cooler
- Exhaust system: water-cooled exhaust pipe

# E0834

## Technical data

### Technical features E0834

Mode of operation		COP with natural gas					COP with special gas		
		1 500 (50)			1 800 (60)		1 500 (50)	1 800 (60)	
at engine speed		rpm (Hz)							
Engine version		E 312	E 302	LE 302	E 312	E 302	LE 302 <sup>4)</sup>	LE 302	LE 302 <sup>4)</sup>
Bore	mm	108	108	108	108	108	108	108	108
Stroke	mm	125	125	125	125	125	125	125	125
Displacement	l	4.6	4.6	4.6	4.6	4.6	4.6	4.6	4.6
ISO standard power <sup>5)</sup>	kW	37	54	68	45	62	68	68	68
Air-fuel ratio	$\lambda$	1.5	1.0	1.6	1.5	1.0	1.6	1.4	1.45
Coolant heat <sup>1)</sup>	kW	29	46	54	31	51	54	52	55
Exhaust heat based on 120 °C <sup>1)</sup>	kW	26	33	33	35	40	37	35	38
Efficiency <sup>1)</sup>									
– mechanical <sup>5)</sup>	%	33.0	36.5	38.4	31.9	36.5	37.6	38.3	37.2
– thermal	%	49.1	53.5	53.1	46.8	53.7	51.9	52.0	52.5
– total	%	82.1	90.0	91.5	78.7	90.2	89.5	90.2	89.6
Emissions status NO <sub>x</sub> <sup>2)</sup>	mg/Nm <sup>3</sup>	< 500	< 6500	< 500	< 500	< 7 000	< 500	< 500	< 500
Combustion <sup>3)</sup>		m	st	m	m	st	m	m	m

1) at 100 % load

2) with 5 % exhaust-gas oxygen

3) m = lean, st = stoichiometric

4) Data conditional and on request

5) in accordance with German Industrial Standard DIN ISO 3046, Part 1

Technical data is based on a calorific fuel value of 10 kWh/Nm<sup>3</sup> for natural gas and 6 kWh/Nm<sup>3</sup> for special gas. The values are provided for information purposes only and are non-binding.

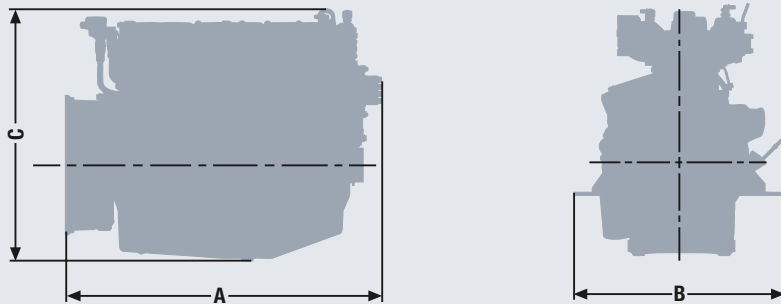

### Dimensions E0834

Type designation		E 312	E 302	LE 302
A-Overall length	mm	862	862	1055
B-Overall width	mm	742	742	809
C-Overall height	mm	870	870	870
Dry weight	kg	430	430	495

All data are reference values. Please request installation drawings for detailed specifications.

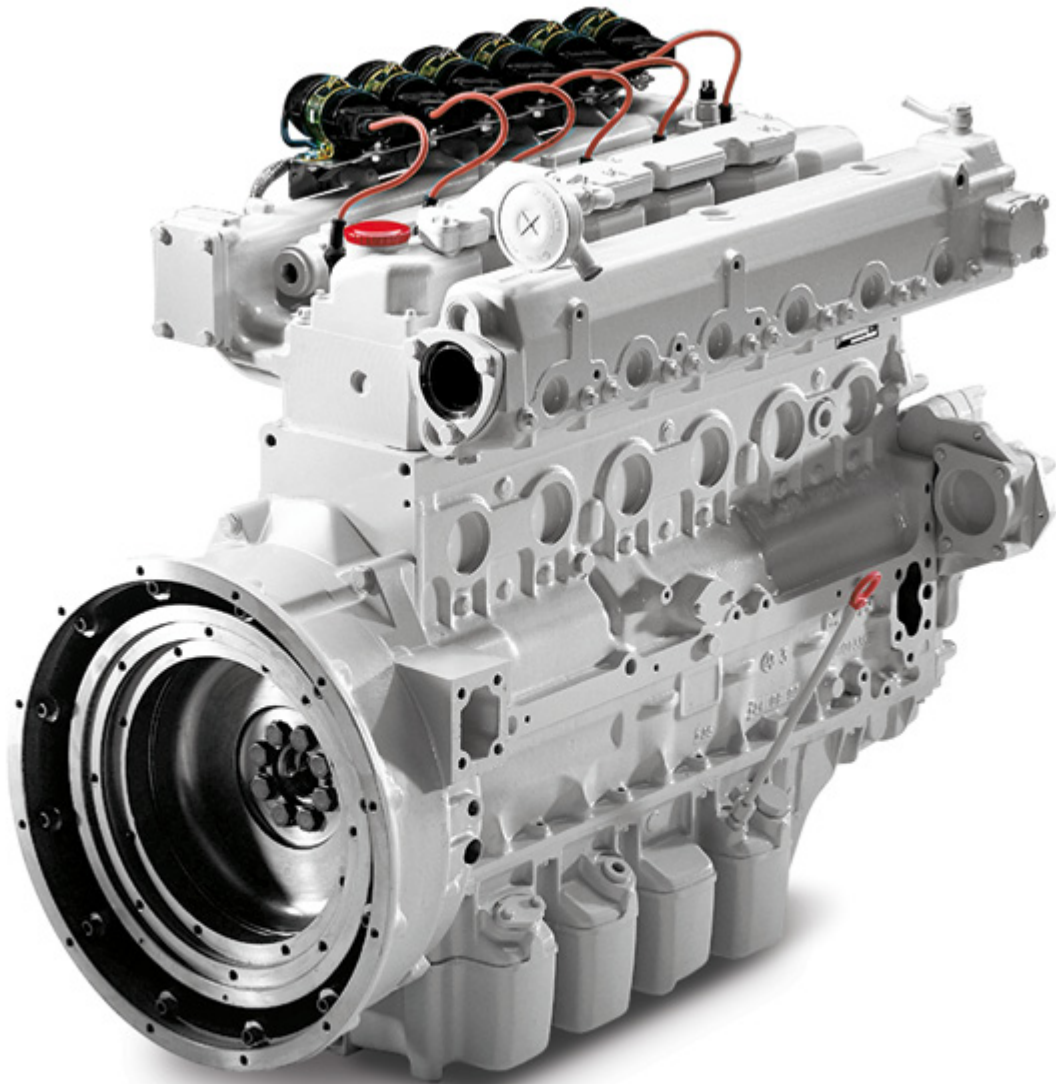

## E0836

### Description of engines

#### Characteristics E0836 E

- Cylinders and arrangement: 6 cylinders in-line
- Mode of operation: four-stroke spark-ignition gas engine
- Engine cooling: water-cooled
- Exhaust system: water-cooled exhaust pipe

#### Characteristics E0836 LE

- Cylinders and arrangement: 6 cylinders in-line
- Mode of operation: four-stroke spark-ignition gas engine
- Turbocharging: turbo charger with pressure-oil lubricated bearings and water-cooled bearing pedestal
- Engine cooling: water-cooled
- Air-fuel mixture cooling: two-stage cooler

# E0836

## Technical data

### Technical features E0836

Mode of operation		COP with natural gas						COP with special gas	
		1 500 (50)			1 800 (60)			1 500 (50)	1 800 (60)
at engine speed rpm (Hz)									
Engine version		E 312	E 302	LE 202	E 312	E 302	LE 202	LE 202	LE 202
Bore	mm	108	108	108	108	108	108	108	108
Stroke	mm	125	125	125	125	125	125	125	125
Displacement	l	6.9	6.9	6.9	6.9	6.9	6.9	6.9	6.9
ISO standard power <sup>4)</sup>	kW	56	75	110	64	85	110	110	110
Air-fuel ratio	$\lambda$	1.5	1.0	1.6	1.5	1.0	1.6	1.4	1.4
Coolant heat <sup>1)</sup>	kW	41	63	68	58	70	74	68	77
Exhaust heat based on 120 °C <sup>1)</sup>	kW	37	46	64	48	55	69	59	67
Efficiency <sup>1)</sup>									
– mechanical <sup>4)</sup>	%	34.4	36.7	39.0	33.3	36.4	37.0	40.5	38.6
– thermal	%	47.9	53.3	49.1	55.2	53.6	50.7	49.6	53.7
– total	%	82.2	90.1	88.1	88.5	90.0	87.7	90.1	92.3
Emissions status NO <sub>x</sub> <sup>2)</sup>	mg/Nm <sup>3</sup>	< 500	< 7 000	< 500	< 500	< 7 000	< 500	< 500	< 500
Combustion <sup>3)</sup>		m	st	m	m	st	m	m	m

1) at 100 % load

2) with 5 % exhaust-gas oxygen

3) m = lean, st = stoichiometric

4) in accordance with German Industrial Standard DIN ISO 3046, Part 1

Technical data is based on a calorific fuel value of 10 kWh/Nm<sup>3</sup> for natural gas and 6 kWh/Nm<sup>3</sup> for special gas. The values are provided for information purposes only and are non-binding.

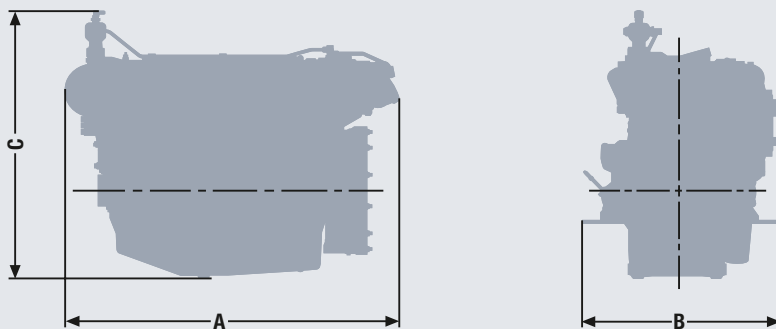

### Dimensions E0836

Type designation		E 312	E 302	LE 202
A-Overall length	mm	1090	1090	1300
B-Overall width	mm	740	740	740
C-Overall height	mm	930	930	1030
Dry weight	kg	520	520	605

All data are reference values. Please request installation drawings for detailed specifications.



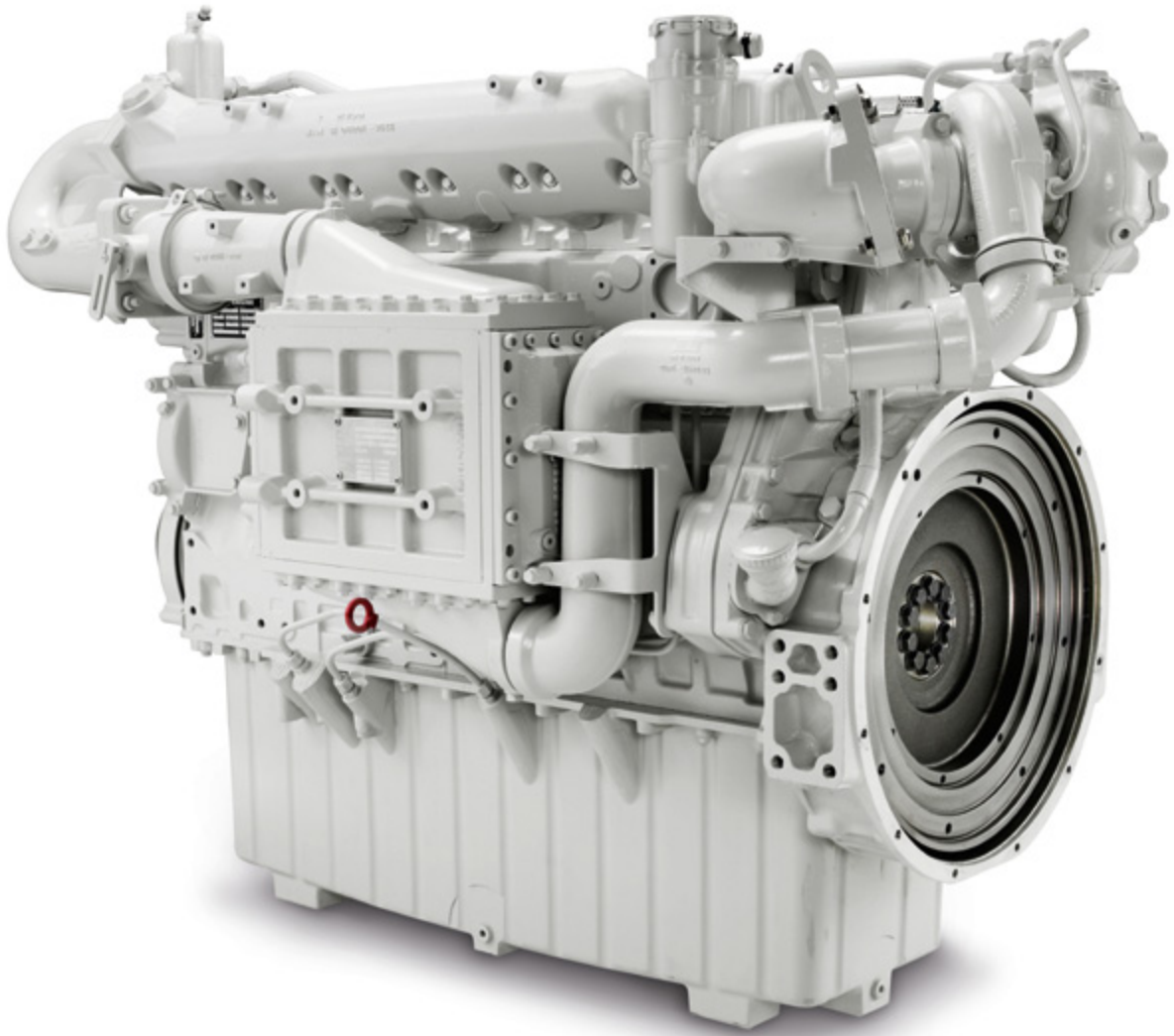

## E2876

### Description of engines

#### Characteristics E2876 TE and LE

- Cylinders and arrangement: 6 cylinders in-line
- Mode of operation: four-stroke spark-ignition gas engine
- Turbocharging: turbo charger with water-cooled turbine housing and pressure-oil lubricated bearings
- Engine cooling: water-cooled
- Air-fuel mixture cooling: two-stage cooler in the case of LE 302/202/212

#### Characteristics E2876 E

- Cylinders and arrangement: 6 cylinders in-line
- Mode of operation: four-stroke spark-ignition gas engine
- Engine cooling: water-cooled
- Exhaust system: water-cooled exhaust pipe

# E2876

## Technical data

### Technical features E2876

Mode of operation		COP with natural gas					COP with special gas			
		1 500 (50)		1 800 (60)			1 500 (50)		1 800 (60)	
at engine speed rpm (Hz)										
Engine version		E 312	LE 212	LE 302	E 312 <sup>4)</sup>	LE 302	TE 302	LE 202	TE 302	LE 302
Bore	mm	128	128	128	128	128	128	128	128	128
Stroke	mm	166	166	166	166	166	166	166	166	166
Displacement	l	12.8	12.8	12.8	12.8	12.8	12.8	12.8	12.8	12.8
ISO standard power <sup>5)</sup>	kW	150	220	210	170	210	130	220	130	200
Air-fuel ratio	λ	1.0	1.6	1.6	1.0	1.6	1.4	1.4	1.4	1.4
Coolant heat <sup>1)</sup>	kW	128	110	99	145	106	124	103	132	106
Exhaust heat based on 120 °C <sup>1)</sup>	kW	79	118	143	98	157	57	127	60	137
Efficiency <sup>1)</sup>										
– mechanical <sup>5)</sup>	%	38.4	41.0	39.0	38,0	37.0	38.0	40.4	36.6	38.5
– thermal	%	52.8	46.0	48.9	54.1	50.7	52.8	44.7	54.0	50.8
– total	%	91.2	87.0	87.9	92.1	87.7	90.8	85.1	90.6	89.3
Emissions status NO <sub>x</sub> <sup>2)</sup>	mg/Nm <sup>3</sup>	< 4 500	< 500	< 500	< 4 250	< 500	< 500	< 500	< 500	< 500
Combustion <sup>3)</sup>		st	m	m	st	m	m	m	m	m

1) at 100 % load

2) with 5 % exhaust-gas oxygen

3) m = lean, st = stoichiometric

4) Data conditional and on request

5) in accordance with German Industrial Standard DIN ISO 3046, Part 1

Technical data is based on a calorific fuel value of 10 kWh/Nm<sup>3</sup> for natural gas and 6 kWh/Nm<sup>3</sup> for special gas. The values are provided for information purposes only and are non-binding.

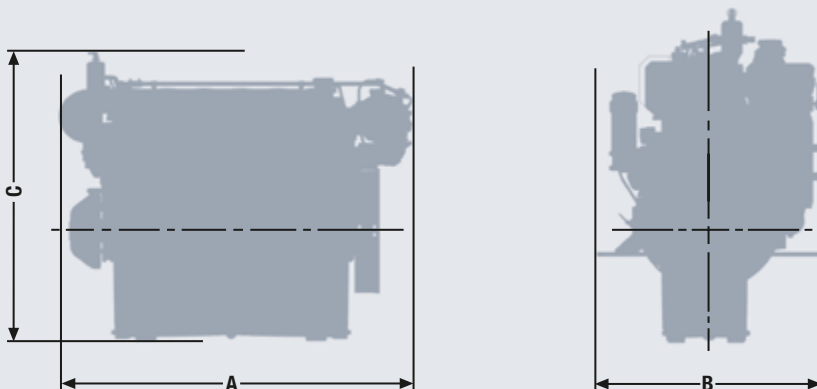

### Dimensions E2876

Type designation		E 312	TE 302	LE 302	LE 202/LE 212
A-Overall length	mm	1 330	1 545	1 520	1 520
B-Overall width	mm	830	835	830	830
C-Overall height	mm	1 166	1 226	1 226	1 226
Dry weight	kg	830	920	990	985

All data are reference values. Please request installation drawings for detailed specifications.



## E2676

### Description of engines

#### Characteristics E2676

- Cylinders and arrangement: 6 cylinders in-line
- Mode of operation: four-stroke spark-ignition gas engine
- Turbocharging: turbo charger with water-cooled turbine housing and pressure-oil lubricated bearings
- Engine cooling: water-cooled
- Air-fuel mixture cooling: two-stage cooler

# E2676

## Technical data

### Technical features E2676

Mode of operation		COP with natural gas		COP with special gas	
		1 500 (50)	1 800 (60)	1 500 (50)	1 800 (60)
at engine speed	rpm (Hz)				
Engine version		LE 202	LE 202 <sup>4)</sup>	LE 212	LE 212 <sup>4)</sup>
Bore	mm	126	126	126	126
Stroke	mm	166	166	166	166
Displacement	l	12.4	12.4	12.4	12.4
ISO standard power <sup>5)</sup>	kW	220	250	220	250
Air-fuel ratio	$\lambda$	1.73	1.72	1.62	1.61
Coolant heat <sup>1)</sup>	kW	110	113	108	121
Exhaust heat based on 120 °C <sup>1)</sup>	kW	121	148	113	137
Efficiency <sup>1)</sup>					
– mechanical <sup>5)</sup>	%	43.4	41.1	42.2	40.3
– thermal	%	46.8	46.4	44.1	46.4
– total	%	90.2	87.5	86.3	86.7
Emissions status NO <sub>x</sub> <sup>2)</sup>	mg/Nm <sup>3</sup>	< 500	< 500	< 500	< 500
Combustion <sup>3)</sup>		m	m	m	m

1) at 100 % load

2) with 5 % exhaust-gas oxygen

3) m = lean, st = stoichiometric

4) Data conditional and on request

5) in accordance with German Industrial Standard DIN ISO 3046, Part 1

Technical data is based on a calorific fuel value of 10 kWh/Nm<sup>3</sup> for natural gas and 6 kWh/Nm<sup>3</sup> for special gas. The values are provided for information purposes only and are non-binding.

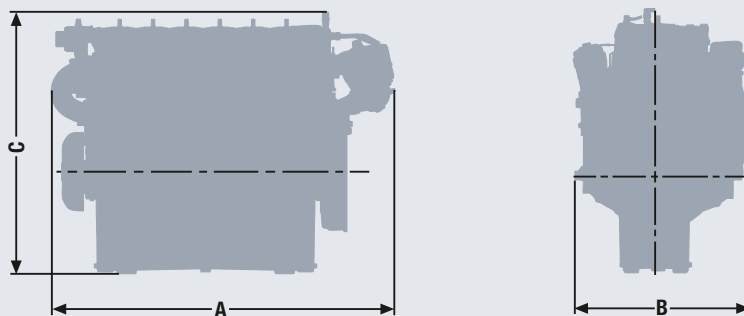

### Dimensions E2676

Type designation		LE 202	LE 212
A-Overall length	mm	1 589	1 589
B-Overall width	mm	808	808
C-Overall height	mm	1 206	1 206
Dry weight	kg	985	985

All data are reference values. Please request installation drawings for detailed specifications.



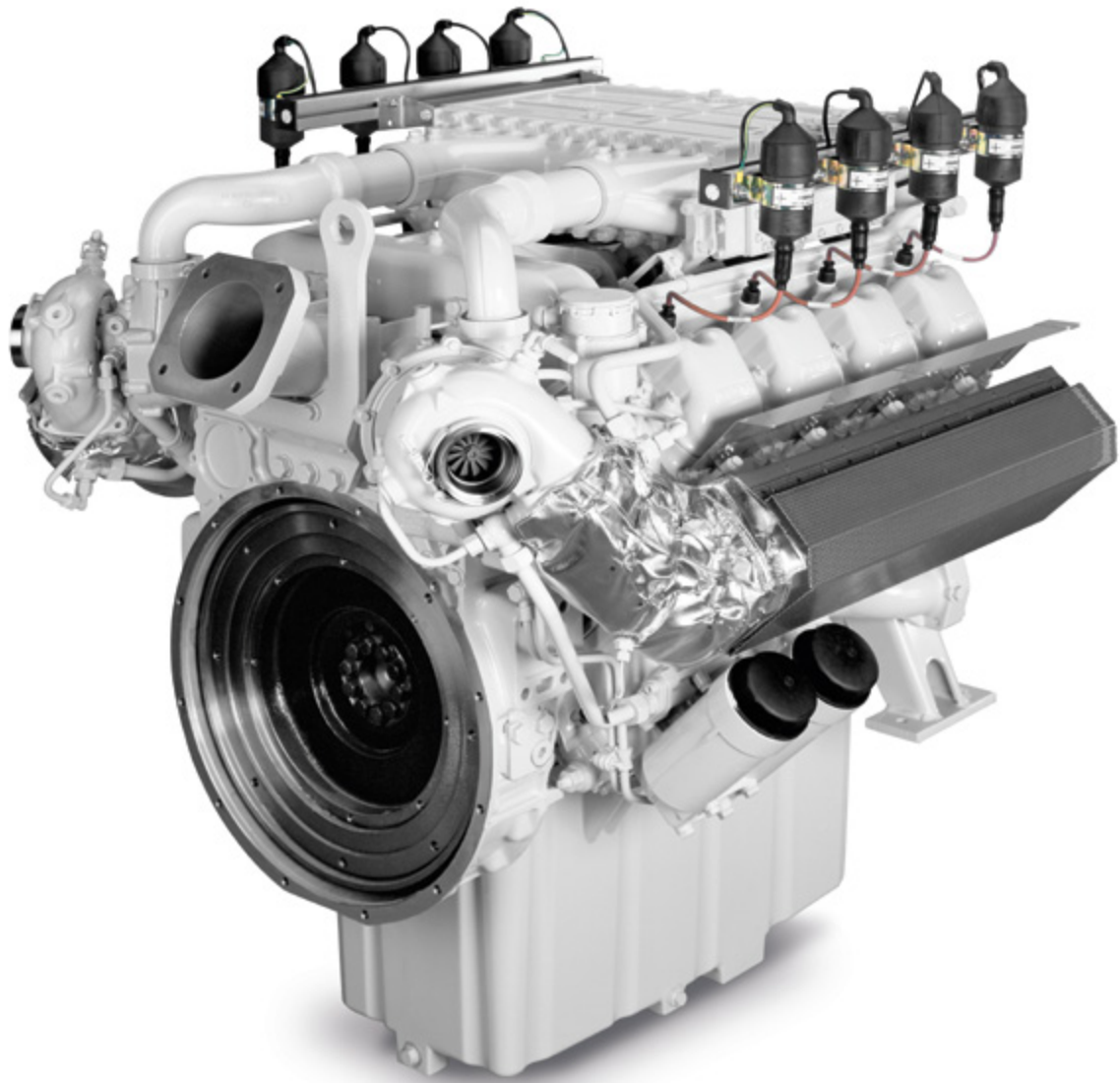

## E2848

### Description of engines

#### Characteristics

- Cylinders and arrangement: 8 cylinders in 90° V arrangement
- Mode of operation: four-stroke spark-ignition gas engine
- Turbocharging: turbo charger with water-cooled turbine housing and pressure-oil lubricated bearings
- Engine cooling: water-cooled
- Air-fuel mixture cooling: two-stage cooler

# E2848

## Technical data

### Technical features E2848

Mode of operation		COP with natural gas		COP with special gas	
		1 500 (50)	1 800 (60)	1 500 (50)	1 800 (60)
at engine speed	rpm (Hz)				
Engine version		LE 322	LE 322 <sup>4)</sup>	LE 322	LE 322 <sup>4)</sup>
Bore	mm	128	128	128	128
Stroke	mm	142	142	142	142
Displacement	l	14.6	14.6	14.6	14.6
ISO standard power <sup>5)</sup>	kW	265	295	265	295
Air-fuel ratio	$\lambda$	1.6	1.6	1.45	1.45
Coolant heat <sup>1)</sup>	kW	130	160	152	182
Exhaust heat based on 120 °C <sup>1)</sup>	kW	147	180	160	194
Efficiency <sup>1)</sup>					
– mechanical <sup>5)</sup>	%	39.0	38.0	40.2	37.7
– thermal	%	48.7	53.0	49.6	51.9
– total	%	87.6	91.0	89.8	89.6
Emissions status NO <sub>x</sub> <sup>2)</sup>	mg/Nm <sup>3</sup>	< 500	< 500	< 500	< 500
Combustion <sup>3)</sup>		m	m	m	m

1) at 100 % load

2) with 5 % exhaust-gas oxygen

3) m = lean, st = stoichiometric

4) Data conditional and on request

5) in accordance with German Industrial Standard DIN ISO 3046, Part 1

Technical data is based on a calorific fuel value of 10 kWh/Nm<sup>3</sup> for natural gas and 6 kWh/Nm<sup>3</sup> for special gas. The values are provided for information purposes only and are non-binding.

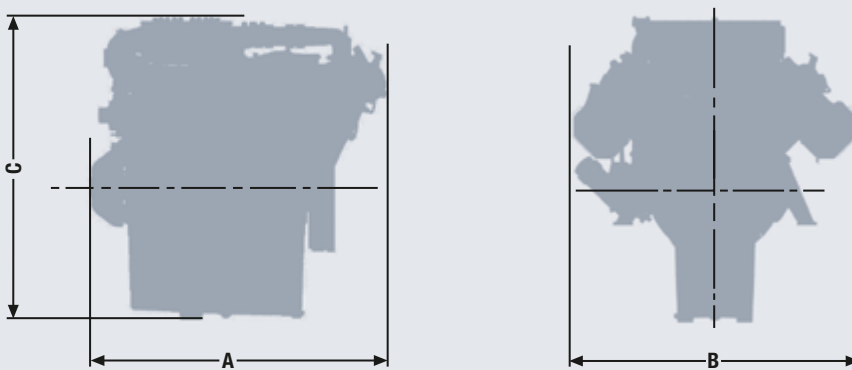

### Dimensions E2848

Type designation		LE 322
A-Overall length	mm	1 210
B-Overall width	mm	1 172
C-Overall height	mm	1 340
Dry weight	kg	1 200

All data are reference values. Please request installation drawings for detailed specifications.

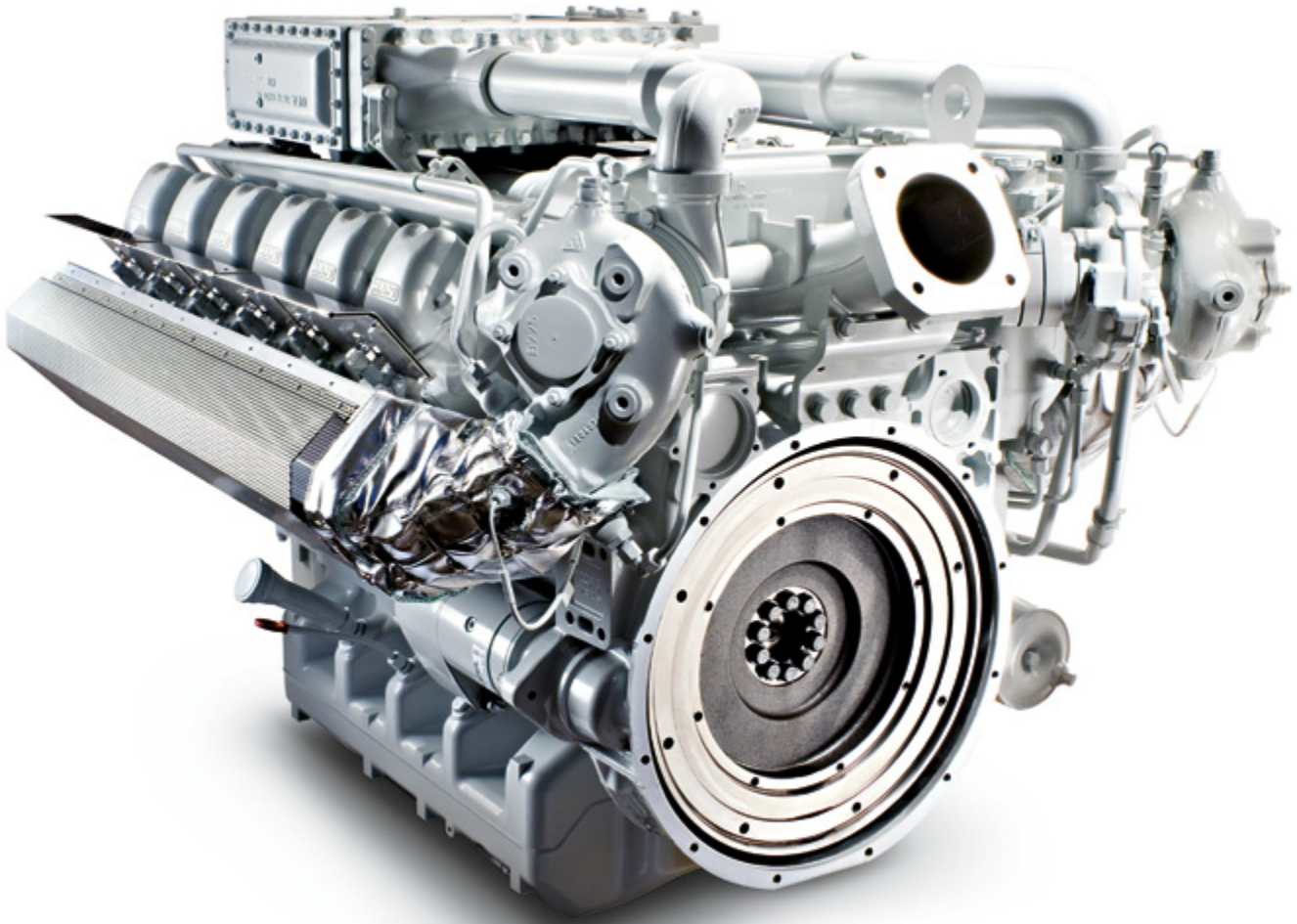

## E2842

### Description of engines

#### Characteristics E2842 E

- Cylinders and arrangement: 12 cylinders in 90° V arrangement
- Mode of operation: four-stroke spark-ignition gas engine
- Engine cooling: water-cooled
- Exhaust system: water-cooled exhaust pipes

#### Characteristics E2842 LE

- Cylinders and arrangement: 12 cylinders in 90° V arrangement
- Mode of operation: four-stroke spark-ignition gas engine
- Turbocharging: turbo charger with water-cooled turbine housing and pressure-oil lubricated bearings
- Engine cooling: water-cooled
- Air-fuel mixture cooling: two-stage cooler

# E2842

## Technical data

### Technical features E2842

Mode of operation		COP with natural gas				COP with special gas	
		1 500 (50)		1 800 (60)		1 500 (50)	1 800 (60)
at engine speed	rpm (Hz)	1 500 (50)		1 800 (60)		1 500 (50)	1 800 (60)
Engine version		E 312	LE 322	E 312 <sup>4)</sup>	LE 332 <sup>4)</sup>	LE 202	LE 322 <sup>4)</sup>
Bore	mm	128	128	128	128	128	128
Stroke	mm	142	142	142	142	142	142
Displacement	l	21.9	21.9	21.9	21.9	21.9	21.9
ISO standard power <sup>5)</sup>	kW	250	420	280	400	420	420
Air-fuel ratio	$\lambda$	1.0	1.6	1.0	1.6	1.45	1.45
Coolant heat <sup>1)</sup>	kW	236	236	260	218	257	264
Exhaust heat based on 120 °C <sup>1)</sup>	kW	129	222	156	242	233	262
Efficiency <sup>1)</sup>							
– mechanical <sup>5)</sup>	%	37.5	40.2	37.2	39.2	40.0	38.4
– thermal	%	54.5	49.1	55.1	50.3	50.2	52.3
– total	%	92.0	89.3	92.4	89.5	90.2	90.7
Emissions status NO <sub>x</sub> <sup>2)</sup>	mg/Nm <sup>3</sup>	< 6 500	< 500	< 6 500	< 500	< 500	< 500
Combustion <sup>3)</sup>		st	m	st	m	m	m

1) at 100 % load

2) with 5 % exhaust-gas oxygen

3) m = lean, st = stoichiometric

4) Data conditional and on request

5) in accordance with German Industrial Standard DIN ISO 3046, Part 1

Technical data is based on a calorific fuel value of 10 kWh/Nm<sup>3</sup> for natural gas and 6 kWh/Nm<sup>3</sup> for special gas. The values are provided for information purposes only and are non-binding.

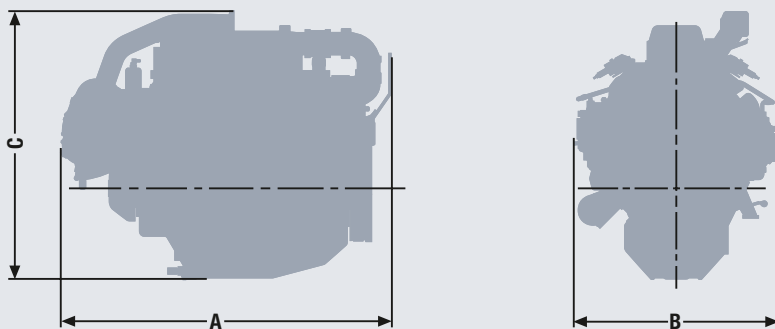

### Dimensions E2842

Type designation		E 312	LE 322/LE 332/LE 202
A-Overall length	mm	1 490	1 570
B-Overall width	mm	1 265	1 142
C-Overall height	mm	1 240	1 155
Dry weight	kg	1 300	1 420

All data are reference values. Please request installation drawings for detailed specifications.



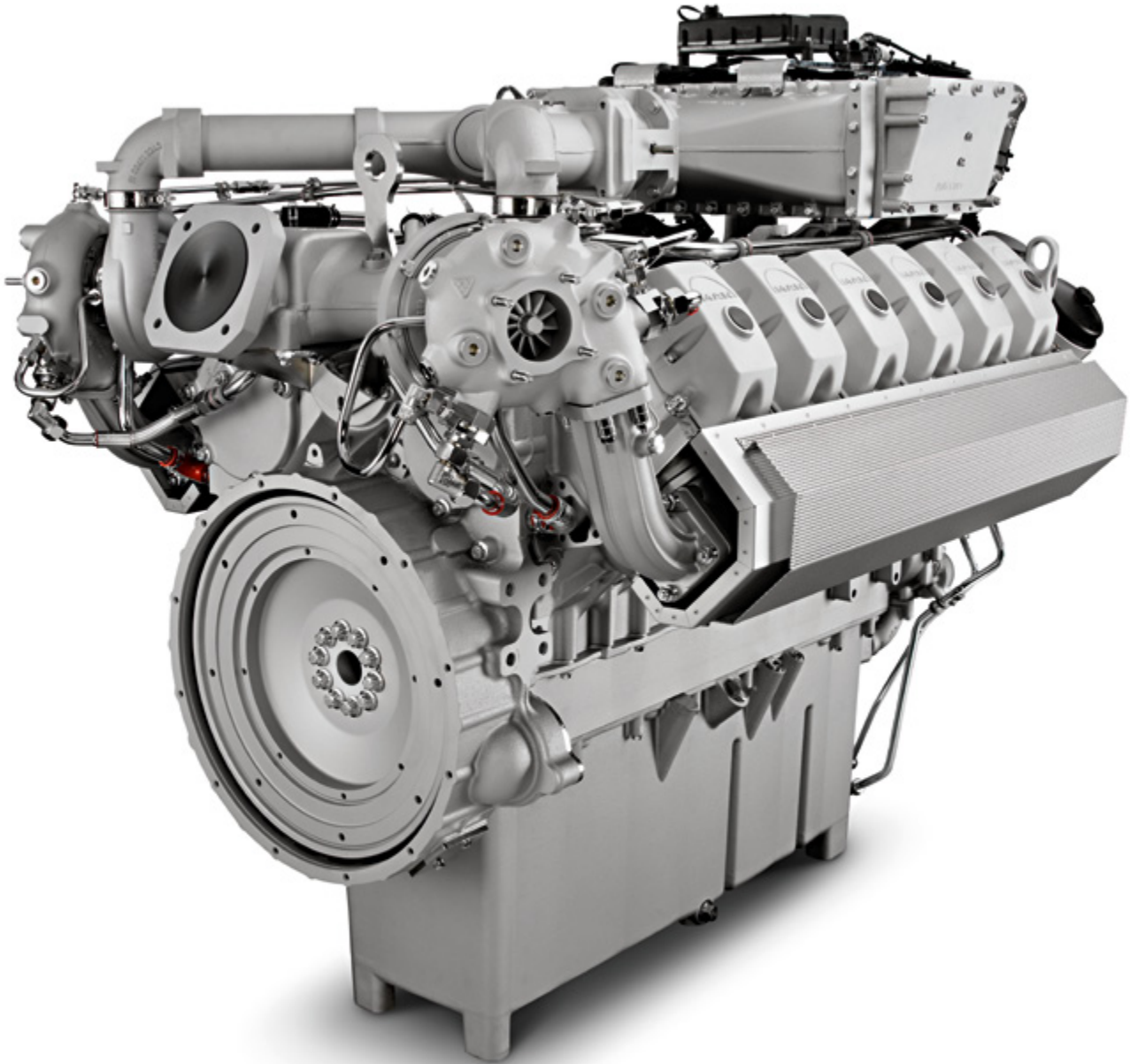

## E3262

### Description of engines

#### Characteristics E3262

- Cylinders and arrangement: 12 cylinders in 90° V arrangement
- Mode of operation: four-stroke spark-ignition gas engine
- Turbocharging: turbo charger with water-cooled turbine housing and pressure-oil lubricated bearings
- Engine cooling: water-cooled
- Air-fuel mixture cooling: two-stage cooler

# E3262

## Technical data

### Technical features E3262

Mode of operation		COP with natural gas		COP with special gas			
		1 500 (50)	1 800 (60)	1 500 (50)		1 800 (60)	
at engine speed	rpm (Hz)	1 500 (50)	1 800 (60)	1 500 (50)		1 800 (60)	
Engine version		LE 202	LE 202 <sup>4)</sup>	LE 202	LE 212 <sup>4)</sup>	LE 202 <sup>4)</sup>	LE 212 <sup>4)</sup>
Bore	mm	132	132	132	132	132	132
Stroke	mm	157	157	157	157	157	157
Displacement	l	25.8	25.8	25.8	25.8	25.8	25.8
ISO standard power <sup>5)</sup>	kW	550	580	550	550	580	580
Air-fuel ratio	$\lambda$	1.68	1.7	1.55	1.60	1.52	1.56
Coolant heat <sup>1)</sup>	kW	336	392	339	317	397	384
Exhaust heat based on 120 °C <sup>1)</sup>	kW	312	339	315	299	375	347
Efficiency <sup>1)</sup>							
– mechanical <sup>5)</sup>	%	41.0	39.4	41.0	41.9	38.4	40,0
– thermal	%	48.3	49.9	48.1	47.0	51.6	49.8
– total	%	89.3	89.3	89.1	88.9	90.0	89.8
Emissions status NO <sub>x</sub> <sup>2)</sup>	mg/Nm <sup>3</sup>	500	500	500	500	500	500
Combustion <sup>3)</sup>		m	m	m	m	m	m

1) at 100% load

2) with 5% exhaust-gas oxygen

3) m = lean, st = stoichiometric

4) Data conditional and on request

5) in accordance with German Industrial Standard DIN ISO 3046, Part 1

Technical data is based on a calorific fuel value of 10 kWh/Nm<sup>3</sup> for natural gas and 6 kWh/Nm<sup>3</sup> for special gas. The values are provided for information purposes only and are non-binding.

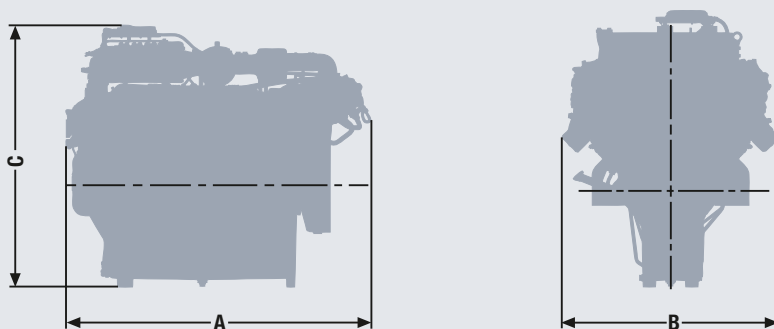

### Dimensions E3262

Type designation		LE 202/LE 212
A-Overall length	mm	1 748
B-Overall width	mm	1 243
C-Overall height	mm	1 500
Dry weight	kg	1 849

All data are reference values. Please request installation drawings for detailed specifications.

# Notes

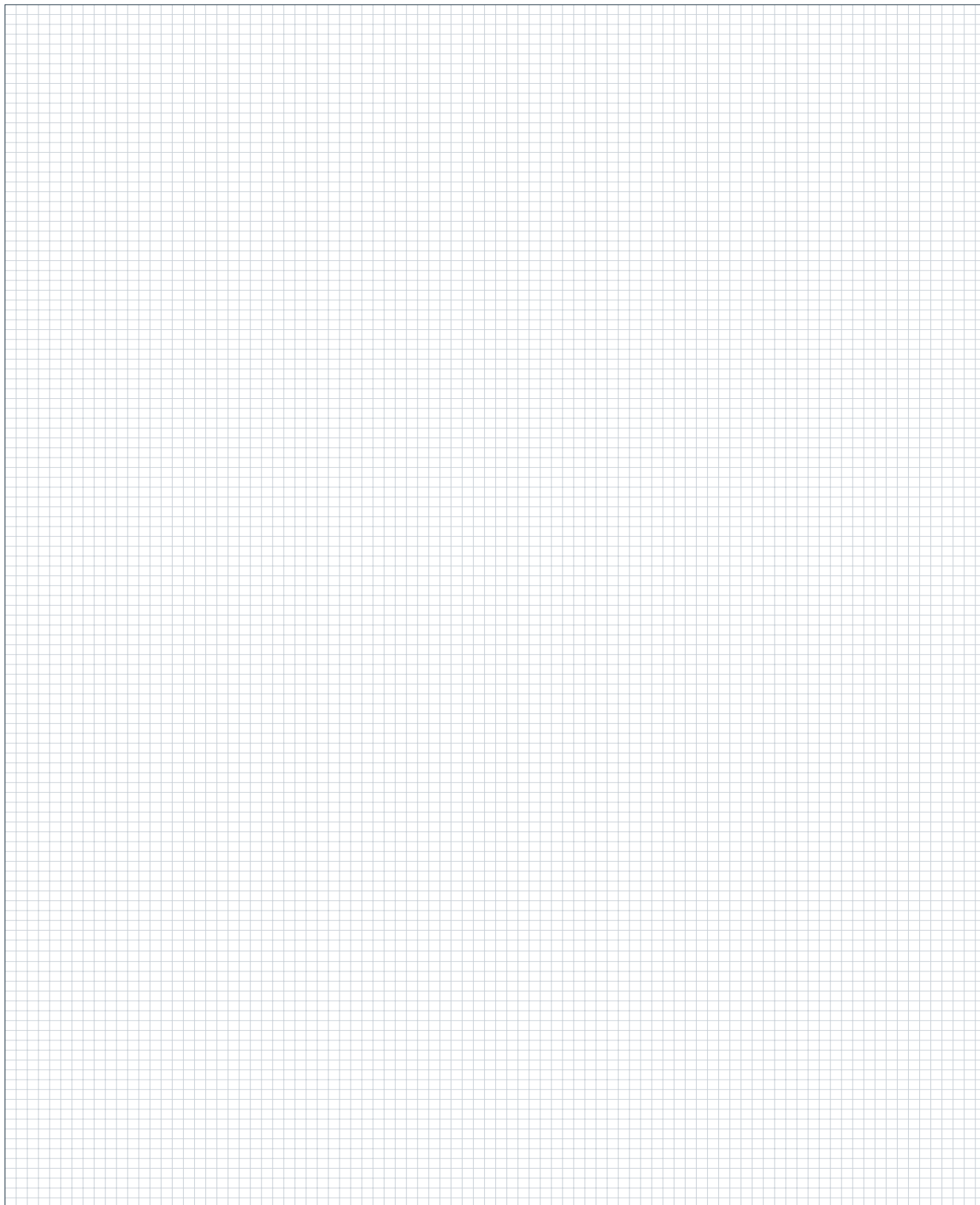





D 114.575/e · mu 10132 · Printed in Germany

All data provided in this document is non-binding. This data serves informational purposes only and is especially not guaranteed in any way. Depending upon the subsequent specific individual projects, the relevant data may be subject to changes and will be assessed and determined individually for each project. This will depend on the particular characteristics of each individual project, especially specific site and operational conditions.

**MAN Truck & Bus AG**

Vogelweiherstr. 33  
90441 Nuremberg, Germany  
man-engines@man.eu  
www.man-engines.com