



## **Master Thesis**

# **Innovation and design of the battery box for electric vehicles**

*Study programme:* N0788A270005 Innovation and Industrial Engineering  
*Author:* **Bc. Chyva Hout**  
*Thesis Supervisors:* doc. Ing. Michal Petrů, Ph.D.  
Department of Machine Elements and Mechanisms

Liberec 2024



## Master Thesis Assignment Form

# Innovation and design of the battery box for electric vehicles

*Name and surname:* **Bc. Chyva Hout**  
*Identification number:* S21000190  
*Study programme:* N0788A270005 Innovation and Industrial Engineering  
*Assigning department:* Department of Machine Elements and Mechanisms  
*Academic year:* 2023/2024

### Rules for Elaboration:

This master's thesis is focused on the innovation and design of the battery box for electric vehicles. The first part of the thesis starts with a literature review to state the current topic of electric vehicles with lithium-ion batteries to give a clear picture of the knowledge on thermal management systems and materials selection for battery boxes. Furthermore, the first part also deals with exploring and analyzing the information about the current state and concepts from the battery boxes available in the patent and non-patent databases. In the next step, the design of five concepts was generated with the description of their technical system explained and illustrated by sketching. The final concept was selected based on selection criteria using the AHP (Analytic Hierarchy Process) method for creating the 3D model. The final part deals with numerical simulation to calculate the temperatures inside the battery box that are generated by prismatic battery cells. This work also includes a drawing of the final concept and drawings of selected system components.

*Scope of Graphic Work:* 8  
*Scope of Report:* 65  
*Thesis Form:* printed/electronic  
*Thesis Language:* english

### **List of Specialised Literature:**

- [1] N. Sato Thermal behavior analysis of lithium-ion batteries for electric and hybrid vehicles. J Power Sources, 99 (2001), pp. 70-77.
- [2] S. Arora, W. Shen, A. Kapoor. Review of mechanical design and strategic placement technique of a robust battery pack for electric vehicles. Renewable and Sustainable Energy Reviews, 60 (2016), pp. 1319-1331
- [3] N. Lewchalermwong, M. Masomtob, V. Lailuck and C. Charoenphonphanich. Material selection and assembly method of battery pack for compact electric vehicle, IOP Conference Series: Materials Science and Engineering, Volume 297, 8th TSME-International Conference on Mechanical Engineering (TSME-ICoME 2017) 12–15 December 2017, Bangkok, Thailand
- [4] Research on the design process of car carbon fiber battery box
- [5] QUERY: "BATTERY BOX" AND ELECTRIC VEHICLE. In Patent Inspiration. Available from: <https://app.patentinspiration.com/#report/E57FA8D843A6/filter>.

*Thesis Supervisors:* doc. Ing. Michal Petrů, Ph.D.  
Department of Machine Elements and Mechanisms

*Date of Thesis Assignment:* November 14, 2023

*Date of Thesis Submission:* May 15, 2025

doc. Ing. Jaromír Moravec, Ph.D.  
Dean

L.S.

doc. Ing. Michal Petrů, Ph.D.  
Head of Department

Liberec November 14, 2023

## Declaration

I hereby certify, I, myself, have written my master thesis as an original and primary work using the literature listed below and consulting it with my thesis supervisor and my thesis counsellor.

I acknowledge that my master thesis is fully governed by Act No. 121/2000 Coll., the Copyright Act, in particular Article 60 – School Work.

I acknowledge that the Technical University of Liberec does not infringe my copyrights by using my master thesis for internal purposes of the Technical University of Liberec.

I am aware of my obligation to inform the Technical University of Liberec on having used or granted license to use the results of my master thesis; in such a case the Technical University of Liberec may require reimbursement of the costs incurred for creating the result up to their actual amount.

At the same time, I honestly declare that the text of the printed version of my master thesis is identical with the text of the electronic version uploaded into the IS/STAG.

I acknowledge that the Technical University of Liberec will make my master thesis public in accordance with paragraph 47b of Act No. 111/1998 Coll., on Higher Education Institutions and on Amendment to Other Acts (the Higher Education Act), as amended.

I am aware of the consequences which may under the Higher Education Act result from a breach of this declaration.

January 2, 2024

Bc. Chyva Hout

## **Acknowledgement**

I would like to acknowledge and thank my supervisor, doc. Ing. Michal Petrů Ph.D. who made this work possible. His patient supervision, guidance, consultation, and valuable advice carried me through all the stages of writing this master's thesis. Special thanks go to Ing. Josef Vosáhlo for huge help with the stage of the numerical simulation. Finally, I would like to thank my family for their continuous support during my studies and thesis writing.

## **Abstrakt**

Diplomová práce se zaměřuje na inovaci a návrh nového bateriového boxu pro elektromobily. Úvodní část práce začíná rešerší literatury, která přiblíží aktuální téma ohledně využívání lithium-iontové baterie pro elektrické vozidla, dále poskytuje komplexní pochopení systémů tepelného managementu a výběr materiálů pro konstrukci bateriových boxů. Kromě toho úvodní část také zahrnuje stadium informací ohledně současného stavu a konstrukčních řešení bateriových boxů nalezených v patentových i nepatentových databázích. Následně bylo vyvinuto pět koncepčních návrhů, kde každý byl doplněn popisem a ilustrovanými náčrty charakterizující jeho technický systém. Finální koncept byl vybrán na základě specifických kritérií pomocí metody AHP (Analytic Hierarchy Process) pro usnadnění tvorby 3D modelu. Poslední část využívá numerické simulace k výpočtu teplotního pole pro studii bateriovými článků uvnitř boxu. Součástí práce je i technická dokumentace finálního konceptu a částí vybraných komponent bateriového systému.

## **Klíčová slova**

Box pro baterie, konstrukce a inovace, elektrické vozidla, teplotní management, koncepty, AHP

## **Abstract**

This master's thesis concentrates on innovating and designing the new battery box for electric vehicles. The initial section of the thesis commences with a literature review to outline the current theme of electric vehicles using lithium-ion batteries, providing a comprehensive understanding of thermal management systems and the selection of materials for constructing battery boxes. Moreover, the initial section also involves investigating and examining information regarding the current status and ideas related to battery boxes found in both patent and non-patent databases. Subsequently, five conceptual designs were developed, each accompanied by an explanation and illustrated sketches detailing its technical system. The ultimate concept was chosen based on specific criteria using the AHP (Analytic Hierarchy Process) method to facilitate the creation of the 3D model. The final section utilizes numerical simulations to compute the temperatures generated by prismatic battery cells within the enclosure. This thesis also includes drawing of the final concept and parts of selected system components.

## **Key words**

Battery box, design and innovation, electric vehicles, thermal management systems, concepts, AHP

# Table of Contents

List of Figures .....	9
List of Tables .....	12
List of Abbreviation .....	13
1 Introduction.....	14
1.1 The Goal of The Work.....	15
2 Literature Review.....	15
2.1 Overview of EV Battery Boxes Using Lithium-ion Battery.....	15
2.1.1 Thermal Management.....	15
2.1.2 Active Thermal Management Systems.....	20
2.1.3 Passive Thermal Management Systems .....	23
2.2 Material Selection for Battery Pack .....	24
2.2.1 Use of Metals in Design .....	24
2.2.2 Use of Plastics and Composites in Design.....	25
2.3 Thermal Runaway.....	26
2.3.1 Thermal Barrier .....	27
2.4 Vibration Isolation.....	29
2.5 Battery Pack Placement .....	29
3 General Concept.....	32
3.1 Concept From Patent Research.....	32
3.1.1 Defining Search Queries.....	33
3.1.2 Patent Databases Focused on Battery Box Innovation for Electric Car.....	33
3.1.3 Document CN213782095U.....	35
3.1.4 Document US2021323418A1.....	36
3.1.5 Document US2021305544A1.....	37
3.1.6 Document KR20210036205A .....	38
3.1.7 Document KR101289562B1.....	40
3.1.8 Document US2021260978A1.....	41
3.1.9 Document CN113314783A.....	42

3.1.10	Document CN213936386U .....	43
3.1.11	Materials Cited in Patent Documents .....	43
3.1.12	Problem Areas Cited in Patent Documents.....	45
3.1.13	Evolutionary Potential Analysis Cited in Patent Documents .....	46
3.2	Concept From Non-Patent Research .....	47
3.2.1	Multi-Material Battery Enclosure From LION Smart.....	48
3.2.2	Use of Carbon Fiber/Epoxy and Ribs From TRB Group.....	49
3.2.3	Multi-material EV Battery Enclosure From CSP.....	50
3.2.4	VARI Technology for Carbon Fiber Battery Box.....	51
3.2.5	Plastics Trim EV Batteries' Weight Boost Safety .....	52
3.2.6	Glass-Fiber PP EV Battery Pack From SABIC.....	53
3.3	Conclusion From Patent and Non-Patent Research .....	54
4	Design Concepts .....	55
4.1	Concept 1 .....	55
4.2	Concept 2 .....	56
4.3	Concept 3 .....	56
4.4	Concept 4.....	57
4.5	Concept 5 .....	58
5	Selection Final Concept .....	59
5.1	Selecting Criteria .....	59
5.1.1	Comparison of Criteria .....	60
5.2	Comparison of Concepts According to Criterion.....	61
6	Construction Design.....	65
7	Analysis of Temperature Inside The Battery Box By FEM .....	70
8	Conclusion .....	76
	References.....	78
	Appendix.....	80



## List of Figures

<b>Figure 1</b> : Sources of heat in a lithium-ion battery [8].....	16
<b>Figure 2</b> : Lithium-ion cell temperature ranges [8].....	17
<b>Figure 3</b> : HEV temperature example [8].....	19
<b>Figure 4</b> : Active air cooling schematic [8].....	20
<b>Figure 5</b> : Passive air cooling schematic [8] .....	21
<b>Figure 6</b> : Liquid cooling plates [8] .....	22
<b>Figure 7</b> : Heat sink fins [8] .....	22
<b>Figure 8</b> : All cell phase change composite (PCC™) material [8] .....	23
<b>Figure 9</b> : A robust battery pack with one battery module in each compartment [10] .....	28
<b>Figure 10</b> : A cylindrical battery cell assembly with cell spacers [11] .....	29
<b>Figure 11</b> : Nissan Leaf battery pack [14].....	31
<b>Figure 12</b> : Placement of lithium ion battery pack in Nissan Leaf [15].....	31
<b>Figure 13</b> : Number of patent documents over time (QUERY: "BATTERY BOX" AND VEHICLE, 1981 documents, 1 per patent family) [18].....	34
<b>Figure 14</b> : Geographical analysis of applicants for patent documents (QUERY: "BATTERY BOX" AND VEHICLE, 1981 documents, 1 per patent family) [18] .....	35
<b>Figure 15</b> : Document CN213782095U [19] .....	36
<b>Figure 16</b> : Document US2021323418A1 [19].....	37
<b>Figure 17</b> : Document US2021305544A1 [19].....	38
<b>Figure 18</b> : Document KR20210036205A [19] .....	39
<b>Figure 19</b> : Document KR101289562B1 [19].....	40
<b>Figure 20</b> : Document US2021260978A1 [19].....	41
<b>Figure 21</b> : Document CN113314783A [19] .....	42
<b>Figure 22</b> : Document CN213936386U [19] .....	43
<b>Figure 23</b> : Materials cited in patent documents (QUERY: "BATTERY BOX" AND VEHICLE, 1981 documents, 1 per patent family) [18].....	44
<b>Figure 24</b> : Number of patent documents for each material [18].....	44

<b>Figure 25</b> : Problem areas cited in patent documents (QUERY: "BATTERY BOX" AND VEHICLE, 1981 documents, 1 per patent family) [18].....	45
<b>Figure 26</b> : Number of patent documents for each problem [18].....	45
<b>Figure 27</b> : Evolutionary potential analysis in patent documents (QUERY: "BATTERY BOX" AND VEHICLE, 1981 documents, 1 per patent family) [18] .....	46
<b>Figure 28</b> : Current technical solutions for battery boxes [20] .....	47
<b>Figure 29</b> : Multi-material battery enclosure from LION Smart [21].....	48
<b>Figure 30</b> : Battery box from TRB group [22].....	49
<b>Figure 31</b> : An exploded view of CSP's multi-material battery enclosure [23] .....	50
<b>Figure 32</b> : VARI technology for carbon fiber battery box [24].....	51
<b>Figure 33</b> : Kautex Textron and Lanxess all plastic battery housing [25] .....	52
<b>Figure 34</b> : Battery box from SABIC concept [26].....	53
<b>Figure 35</b> : Concept 1.....	55
<b>Figure 36</b> : Concept 2.....	56
<b>Figure 37</b> : Concept 3.....	57
<b>Figure 38</b> : Concept 4.....	58
<b>Figure 39</b> : Concept 5.....	59
<b>Figure 40</b> : Battery box from composite material .....	66
<b>Figure 41</b> : Battery box body from composite material .....	66
<b>Figure 42</b> : Components inside the battery box .....	67
<b>Figure 43</b> : Battery module .....	67
<b>Figure 44</b> : Components inside the battery module .....	68
<b>Figure 45</b> : Crash structure.....	69
<b>Figure 46</b> : Cooling plate .....	69
<b>Figure 47</b> : Model with distinct materials assigned to different parts in ANSYS .....	70
<b>Figure 48</b> : The boundary condition for Samsung battery SDI 94 Ah.....	71
<b>Figure 49</b> : The boundary condition for environment convection .....	71
<b>Figure 50</b> : The boundary condition for the temperature outside the battery box .....	72
<b>Figure 51</b> : The boundary condition for the coolant temperature .....	72

<b>Figure 52</b> : Mesh generation .....	73
<b>Figure 53</b> : The temperature field outside the battery modules with the cooling system .....	73
<b>Figure 54</b> : The temperature field of the upper surface cooling plate contact with battery modules .....	74
<b>Figure 55</b> : The temperature field of the lower surface cooling plate contact with battery modules .....	74
<b>Figure 56</b> : The temperature field inside the battery box .....	75
<b>Figure 57</b> : The temperature field of cross-section inside the battery box .....	75
<b>Figure 58</b> : The temperature field of the thermal pad between battery cells .....	76

## List of Tables

<b>Table 1</b> : Materials used for battery pack casing in various commercial cars [9].....	24
<b>Table 2</b> : Battery pack and its location in some state of the art commercial cars [9].....	30
<b>Table 3</b> : The number of responses to selected terms in the Google search engine.....	47
<b>Table 4</b> : Pairwise comparison matrix of criteria .....	60
<b>Table 5</b> : Normalization pairwise comparison matrix of criteria .....	61
<b>Table 6</b> : Pairwise comparison matrix of concepts according to lightweight .....	61
<b>Table 7</b> : Normalization pairwise comparison matrix of concepts according to lightweight .....	62
<b>Table 8</b> : Pairwise comparison matrix of concepts according to electrical insulation .....	62
<b>Table 9</b> : Normalization pairwise comparison matrix of concepts according to electrical insulation.....	62
<b>Table 10</b> : Pairwise comparison matrix of concepts according to safety .....	63
<b>Table 11</b> : Normalization pairwise comparison matrix of concepts according to safety .....	63
<b>Table 12</b> : Pairwise comparison matrix of concepts according to cost .....	63
<b>Table 13</b> : Normalization pairwise comparison matrix of concepts according to cost .....	64
<b>Table 14</b> : Pairwise comparison matrix of concepts according to modular design.....	64
<b>Table 15</b> : Normalization pairwise comparison matrix of concepts according to modular design .....	64
<b>Table 16</b> : Table of relative priority .....	65
<b>Table 17</b> : Result of AHP.....	65

## List of Abbreviation

AHP	Analytic Hierarchy Process
AIT	Auto-Ignition Temperature
D-LFT	Direct Long-Fiber Thermoplastic
ECU	Electronic Control Unit
EMI	Electromagnetic Interference
EPA	Environmental Protection Agency
ESS	Energy Storage System
EV	Electric Vehicle
FST	Fire, Smoke and Toxicity
HPDC	High Pressure Die Cast
HEV	Hybrid Electric Vehicle
ICB	Interconnect Board
ICE	Internal Combustion Engine
IP69	Ingress Protection 69
NEDC	New European Driving Cycle
PCM	Phase Change Material
R & D cell	Research And Development Cell
RFI	Radio Frequency Interference
SMC	Sheet Molding Compound
SOC	State Of Charge
SOH	State Of Health
UL	Underwriter's Laboratory
UL 94	Standard Tests for Flammability of Plastic Materials
VARI	Vacuum-Assisted Resin Infusion

# 1 Introduction

The investment in promoting the Electric Vehicles (EVs) industry has been the main focus of the many governments to reduce the import of crude oil and curb CO<sub>2</sub> emissions to minimize the environmental burdens. With extensive policy support from governments, the growth rate of the EV industry and the annual production rate of electric vehicles have increased significantly over the year. This general trend of shifting away from fossil fuel cars' Internal combustion engine (ICE) will result in high demand for electric vehicles (EVs) as electromobility is the most mature alternative propulsion technology. The reason behind it such a shift lies in the development of energy storage systems, such as the battery pack, which is the main power source for driving the transmission system in EVs. Electric cars store energy in battery packs consisting of battery modules comprised of thousands of cells in series or parallel. The most commonly employed batteries are Lithium-ion rechargeable batteries. The battery pack which is comprised of an assembly of battery modules is the main source of power transmission for electric vehicles. During the actual operation of an electric vehicle, the battery packs and its enclosure is subjected to harsh environmental conditions such as external vibrations and shocks due to varying road slopes. This will result in stresses and deformations of different degrees. Vehicle safety heavily depends on the safety of the battery pack which in turn is dependent on its mechanical features, such as the ability to resist deformation and vibration shocks. In addition, the lighter-weight vehicle is preferred because it can increase the range of the vehicle and the life cycle of a battery pack [1]. Recently, the development of battery packs for designing vehicles and reinforcing road safety has been carefully reviewed. Greater emphasis has been paid to the research and development (R&D) cell electrodes materials and design, thermal design of battery packs, new charging configurations, charging infrastructure, and battery modeling methods for estimating the battery state, such as state of charge (SOC) and state of health (SOH) [2]. The existing research aims at preventing some unforeseen events such as short circuits, thermal runaway, etc., which may compromise the safety of drivers, vehicles, and roads [3]. The major enemy of battery and battery packs is the temperature. Due to the joule effect coming from the battery's internal resistance reaction and the reaction heat generated by the chemical reaction of the battery, it would bring a great thermal load to the battery pack. If the heat could not be taken away from the electric vehicle in traveling, it would certainly affect battery performance and life cycle, and may even bring significant risk to the safety [4]. For the existing battery pack cooling problems, the researchers made a series of battery thermal management solutions, including the air cooling method, liquid cooling method, and phase change material cooling method. It has been suggested that the battery temperature must be maintained below 50 °C for safe operation [5], [6].

Another criterion for **designing a battery pack is price**. The main costs of which are battery cells and assembling processes. The battery cell is indeed priced by battery manufacturers, while the assembling cost is dependent on battery pack designs. The Battery pack designers need to do the overall cost as cheap as possible, but it still requires high performance and safety. Material selection and assembly methods such as component design are significant for determining the cost-effectiveness of battery modules and battery packs [7].

## **1.1 The Goal of The Work**

The goal of this Master Thesis is to explore innovative design strategies for the new battery box in electric vehicles with a primary focus on achieving lightweight design by thoroughly exploring materials to develop a light battery box, aiming to optimize the overall weight without compromising structural integrity or safety. Undertake an in-depth investigation into the current status of battery boxes for electric vehicles to explore the existing designs, materials in use, problem areas, and manufacturing processes. By synthesizing this information, identify challenges and opportunities for improvement. Generate five innovative conceptual designs for battery boxes and select the best ultimate concept for creating a detailed 3D model. Utilize numerical simulation techniques to calculate and analyze the temperature distribution within the 3D model of the final battery box concept.

## **2 Literature Review**

### **2.1 Overview of EV Battery Boxes Using Lithium-ion Battery**

#### **2.1.1 Thermal Management**

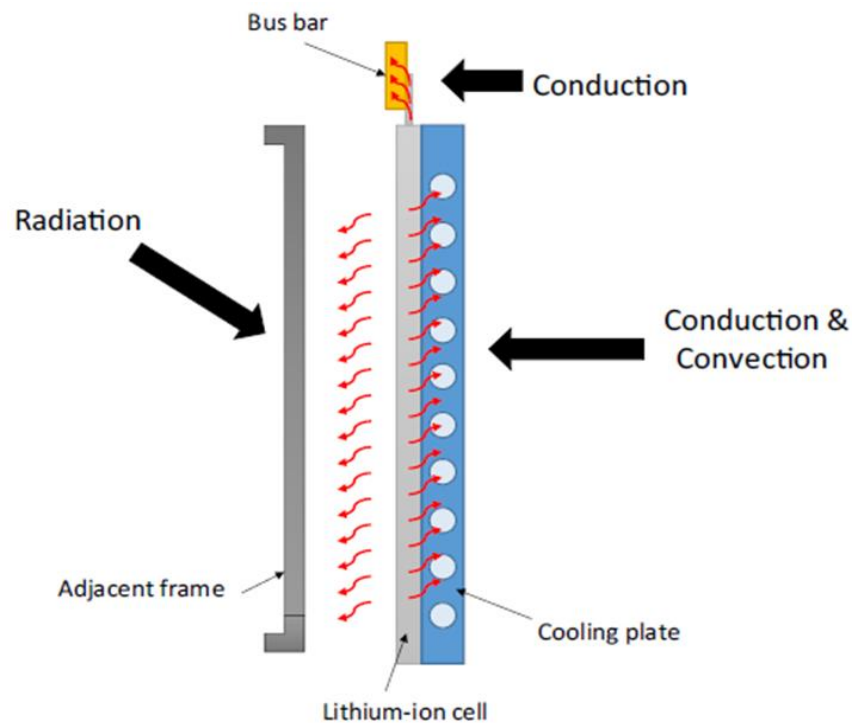
When it comes to lithium-ion cell temperatures, the most important thing to remember is that lithium ion cells like to be maintained at about the same temperature range that people are comfortable, which is about 23 °C (73 °F). The thermal management system should be able to maintain a temperature difference of about 2-3 °C from the coolest cell to the warmest cell. At the worst-case condition, usually for larger packs the difference can be as much as 6-8 °C. The reason why this is important is that a large temperature gradient between the cells will cause the cells to age at different rates. So the hotter cells will age faster than the cooler cells, and if there is a large gradient, this could mean that the battery's calendar life will be reduced prematurely.

There are three different types of heat transfer that need to be considered in battery design: conduction, convection, and radiation. Conduction refers to a direct transfer of heat energy from two objects that are in direct contact. Convection occurs when heat is conducted through a liquid medium to a heat-sinking device. Radiative heat transfer refers to heat energy that generated through electromagnetically thermally charged particles of matter that radiate from one source to another, generally through the air. All three methods of heat transfer must be considered in the battery system design, but conduction and convection will have the greatest impact on the thermal system design. For example, as the cells are discharged they generate heat, that heat will be transferred via conduction to the bus bars and any other components that are in direct contact with the cells. Convective heating and cooling is most typically seen through the use of a liquid cooling plate; however, the movement of cooled air can also provide convective cooling. This is where most of the cooling will take place in the battery system. Finally, radiant heating must be considered in a couple of important areas. First, the radiated heat from the cell to other components that are not in direct contact with the cells can impact adjacent cells. Second, the heat that is being

generated from components such as the electronics will impact the cells if it is not properly managed.

Sources of heat generation inside a battery system come from the chemical reaction within the cell (the main area of heat generation) as the lithium-ions move back and forth during operation; balancing of cells (usually while parked); electronics within the battery pack; and thermal management system. While the lithium-ion cells are the primary source of heat generation inside a pack, the influence of the electronics must not be disregarded as it can be a significant source of heat creation that must be accounted for in your thermal management system design. If adequate shielding and consideration of the placement of these electronics are not considered, then the heat generated by the electronics may actually have a negative impact on the cells life [8].

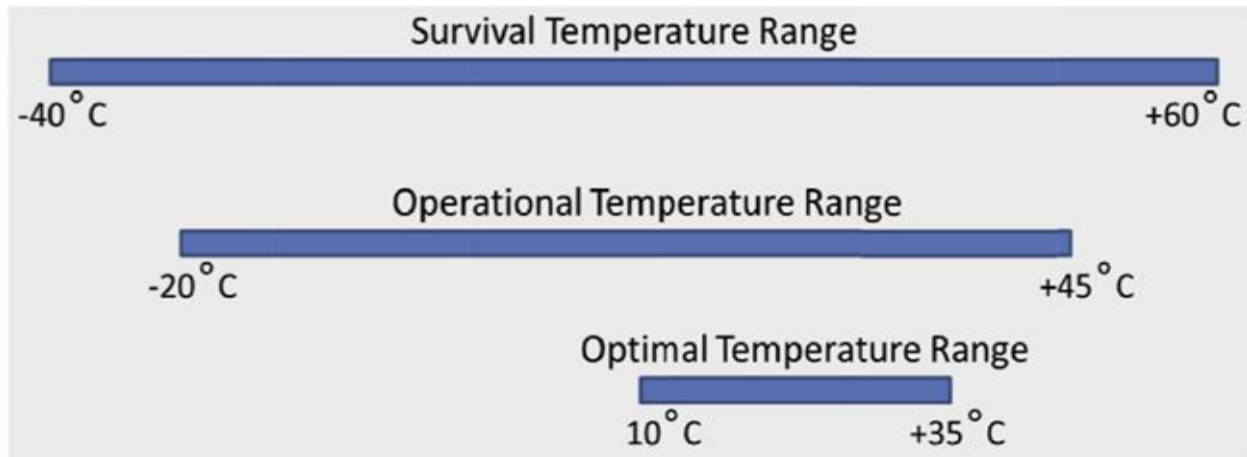
**Figure 1** below offers some simple examples of each of these three methods of heat transfer. In this example, a pouch-type lithium-ion cell is shown with a cooling plate on the right and the adjacent mounting frame on the left. The heat transfer from the cell to the cooling plate uses conduction both in the direct conduction of heat from the cell to the cooling plate and to the liquid cooling channels. These channels then use convection to remove the heat through a liquid medium away from the cells. At the top of the cell, a simple copper bus bar is shown being connected to the tab of the cell. This demonstrates the heat transfer through direct conduction from the cell to the bus bar. Finally, the frame piece to the left of the cell may be used for mechanical structure of the module; however, even if it is not directly in contact with the cell it will experience radiative heating from the cell.



**Figure 1** : Sources of heat in a lithium-ion battery [8]



Lithium-ion chemistries tend to operate best between about 10 and 35 °C; this is referred to as the optimal temperature range. This is where you want the batteries to be at most of the time. However, most all lithium-ion chemistries will still operate down to about -20 °C and up to about 45 °C; this is known as the operational range. In this temperature range, no reduction in battery life would be expected to be experienced during normal operation. Between -20 and -40 °C the electrolytes may begin to freeze and the cold temperatures increase the impedance within the cell thereby resisting the flow of ions and reducing capacity and performance, and above 60 °C many lithium-ion cell chemistries begin to get more unstable; this is known as the survival temperature range (Figure 2).



**Figure 2** : Lithium-ion cell temperature ranges [8]

This brings us to another concept that we should consider, at least briefly, in our thermal system design-thermal mass. Thermal mass is essentially the amount of heat that each object within the pack that has mass (all of them!) can absorb. Much in the same way that a battery can only store so much energy, all of the components in the battery pack can absorb a certain amount of heat, which is directly relative to their mass and the specific thermal properties of that particular material. For example, a copper bus bar will be able to absorb more heat than a plastic cover. Above its maximum ability to absorb heat, the material will begin to breakdown, plastics will melt and/or burn, and metals will begin to melt. Thermal mass will not generally drive major design considerations, other than in some of the components that are directly in contact with the areas of heat generation. However, in a passively cooled pack or an uncooled pack, this concept must be examined to evaluate its impact. Heat capacity may also come into effect if the application is being used in regions of high ambient temperatures. This is because in these regions the battery pack may absorb some of this ambient heat, which will cause the thermal system to have to work much harder in order to remove this heat. An example of this may be seen in regions such as the state of Arizona in the United States. Here, with summer ambient temperatures that may be in range of 38-44 °C (100-110 °F) or higher, the battery pack will absorb that heat and therefore will have to work to cool down the pack from these initial high temperatures back down to 23 °C in order to preserve the life and performance of the battery system.

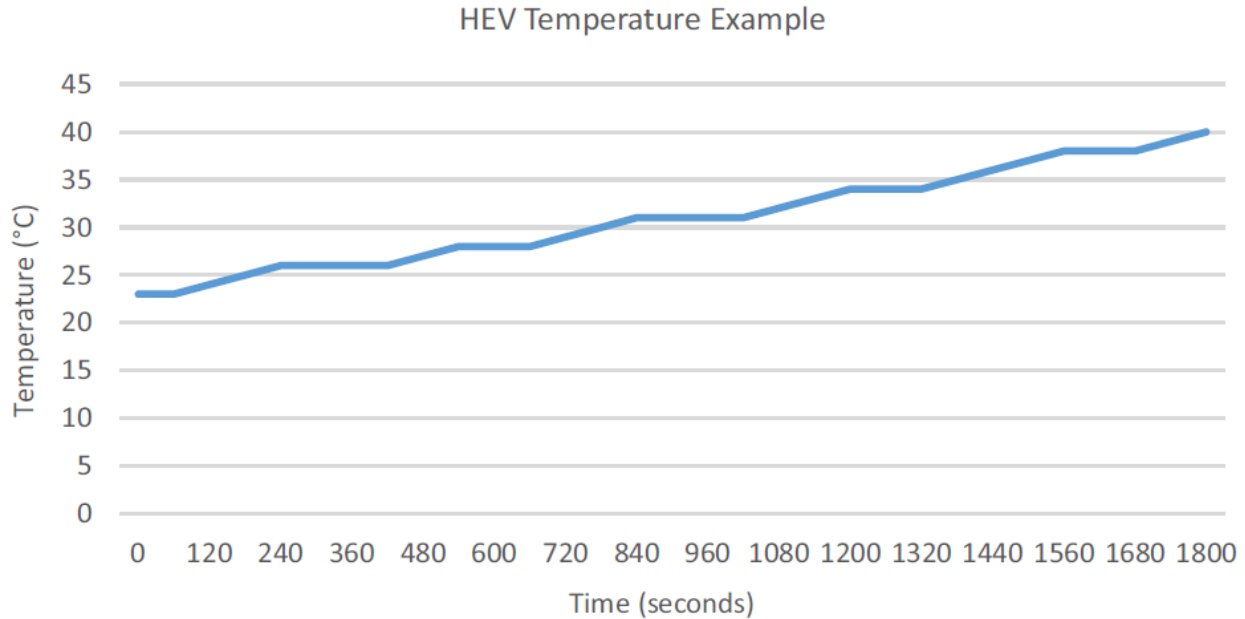
At temperatures above about 90 °C, a polymer-based separator may begin to melt and breakdown, and between 90 and 130 °C the separator will continue to breakdown until a series of internal short circuits between the anode and the cathode are experienced; at this point, the cell will begin to move toward what is known as “thermal runaway.” In effect, thermal runaway means that the cell becomes hot enough to create self-sustaining heat generation and failure is imminent in the form of cells venting and/or explosion (often referred to as “rapid disassembly”). There is no way to stop a cell in thermal runaway once the threshold has been surpassed. The exact temperature that a cell reaches the thermal runaway threshold is different for different chemistries. Some may reach it as low as 120 °C, while others may be able to exceed 140 °C before reaching this event [8].

- **Why Cooling?**

As mentioned above, in order to maximize the potential of lithium-ion cells, they need to be maintained at about 23-25 °C (73-77 °F) throughout the majority of their use cycle. However, under operation, the cells experience an exothermic reaction they begin generating heat due to the rate at which the chemical reaction occurs within the cell and the related increase in cell resistance. This reaction in combination with high ambient (outside) temperatures means that your battery design must be able to cool the batteries down and maintain them within their optimal operating range in order to ensure the performance and life of the overall battery system.

Additionally, high discharge rates generate the exothermic temperature increases within the cells. And when these discharges come frequently, it means that the cells do not have time to cool down between these pulses, which again drive higher temperatures. In addition to this, there is less time for the thermal management system to engage and reduce the temperature of the cells back down. Think of this as a stair-step effect: when you hit your accelerator, a rapid discharge of the battery occurs; with frequent stopping and accelerating events the battery thermal management system will not have time to cool down the battery from the last discharge, causing the battery to gradually but steadily increase in temperature. An example of this is the traditional hybrid electric vehicle (HEV), which will continually discharge and then regeneratively charge the battery regularly during a driving cycle. In this type of usage cycle, the battery may not have time to cool down the cells before another discharge–charge cycle is initiated. This will cause a slow and steady increase in the temperatures within the pack. Allowing the pack to sit unused for a period of time will generally allow the system to reduce the temperature back down to its normal operating range [8].

**Figure 3** below offers an example of what this type of temperature increase may look like. While this is not actual performance data, it is consistent with the type of heat generation that could be expected to be seen in this type of application.



**Figure 3** : HEV temperature example [8]

As mentioned earlier, in high-temperature environments where the ambient air temperature is already in the 30-35 °C range or higher, it becomes even more important to be able to reduce the temperature down below the ambient in order to ensure life, performance, and against catastrophic failure.

- **Why Heating?**

On the other end of the spectrum is heating the battery. As a general rule, battery system designers do not want to heat a battery except for at very low ambient temperatures and even then it should not be a “rapid” heating.

Most liquid electrolytes used in modern lithium-ion batteries will begin to experience reduced power at about -10 °C and will begin to freeze at between -20 and -30 °C, which makes them unable to provide power at very low temperatures.

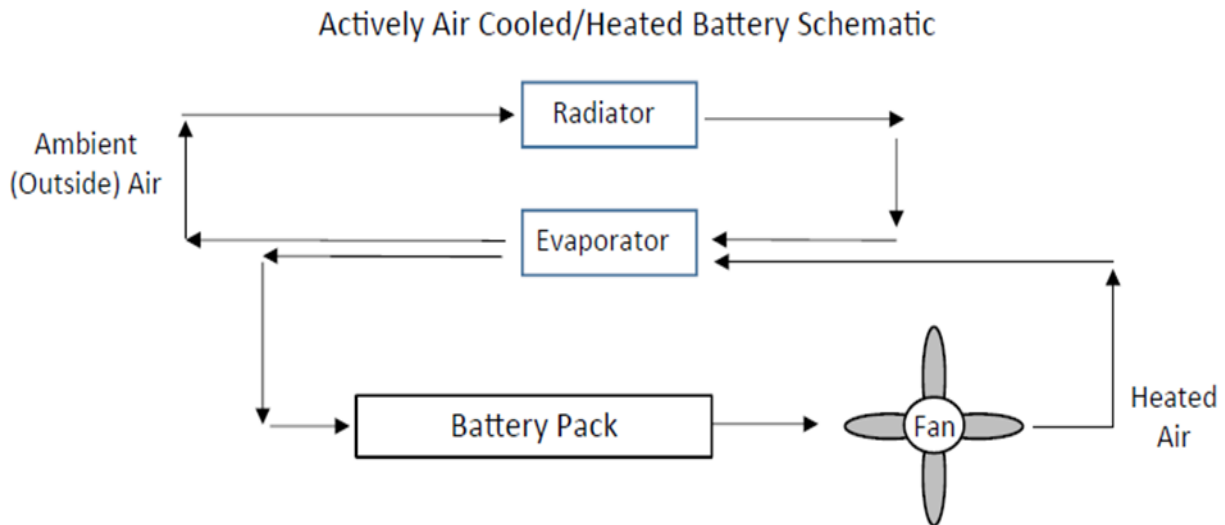
In a liquid-cooled system, a heat pump can be added to the overall system to provide warmed liquid through the cooling loop, which will slowly heat up the batteries. Other methods may also be employed such as using a thin-film heater. In this instance, the heater may not actually be used to heat, but rather to slow the rate of cooling such that if the vehicle sits for a weekend the cells will only be down to 25 °C after several days. This means that the system would have full performance, however, would suffer from some energy loss as the thin-film heater would need to be powered by the battery itself. However, this would be only a minor and temporary capacity loss [8].

## 2.1.2 Active Thermal Management Systems

Active thermal management involves using some medium such as air, liquid, or refrigerant that is forced through the pack and over the cells to reduce temperatures. The two most common methods are air cooling using chilled air that is directed throughout the pack and over the cells and electronics to reduce the temperature of the cells and liquid cooling.

- **Active Air Cooled System**

This generally requires the integration of a fan, ducting, and heat transfer plates of some sort. The benefits are that it can be relatively effective in responding to rapid changes in temperature and has a lower weight than a liquid-cooled system. The other benefit is that the cooled air is directly flowing across the cells. The disadvantages are that air is not as effective a cooling medium as liquid. And depending on air-flow design, it can cause the cells at the beginning of the air flow to be cooler than the cells at the end of the air flow because as the air passes by the initial cells, it begins to pick up the heat so by the time the air passes by the last cells it is warmer than when it initially entered the pack. This uneven cooling can cause the cells to age at different rates, thereby reducing the life of the pack (**Figure 4**).



**Figure 4** : Active air cooling schematic [8]

In addition to using chilled air, some systems will pull ambient air from the outside of the pack, or even inside the cabin, and circulate that air through the pack. In this case, the air must first be filtered and the cooling ability is limited to reducing the temperature only to what the ambient temperature is. So in this instance, if the ambient temperature is at 30 °C the thermal management system will only be able to cool down the battery to 30 °C (**Figure 5**).

### Passively Air Cooled/Heated Battery Schematic



**Figure 5** : Passive air cooling schematic [8]

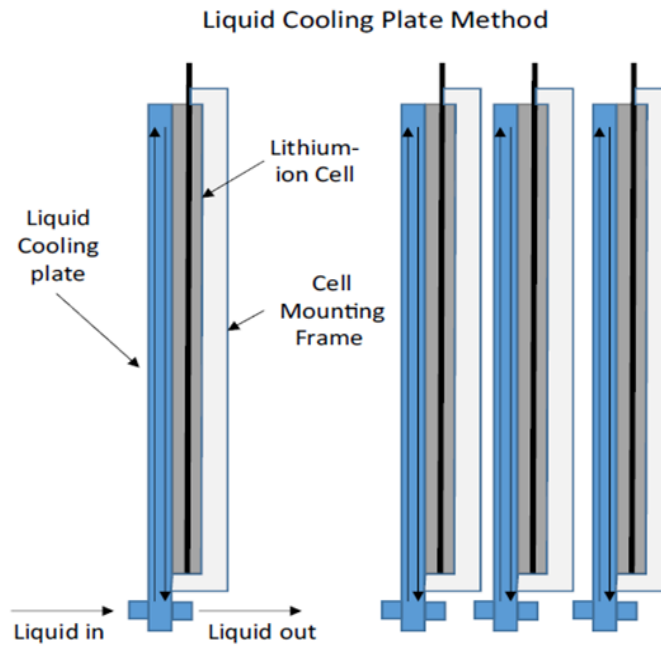
Another challenge of air cooling is that it makes the system design more difficult in the event that the pack needs to be a “sealed” pack design. As the air-cooled pack is essentially an “open system,” it becomes very difficult to achieve an Ingress Protection 69 (IP69) sealing level on the pack, which makes it a very good solution for a pack that is mounted inside the vehicle or inside a building or container, but not as good a solution if it is mounted external to the vehicle.

- **Active Liquid Cooled System**

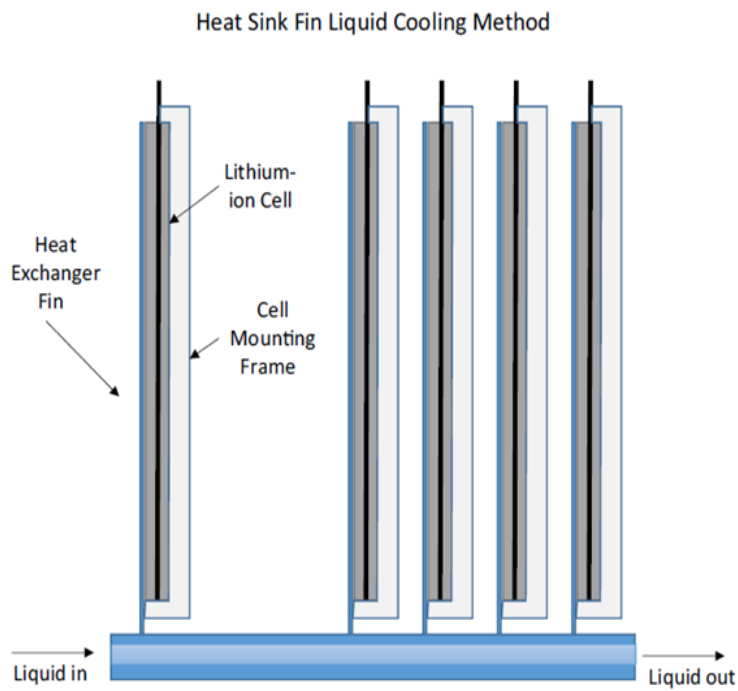
The other common method of active thermal management is by forcing a liquid, often a 50/50 water and glycol mix similar to that used in engine cooling, through a series of plates that are mounted next to the cells. This system involves a liquid distribution system that must be integrated into the pack, most often done through a series of hoses and heat exchangers. The benefit of the liquid cooling system is that it is quite an effective medium for quickly transferring heat away from the cells. It can also, with a heating element in the system, be used to provide heated liquid in order to warm the battery in the cold weather. The disadvantages are that it tends to be a heavier system (greater mass) and there is always a risk of leaks in the battery pack. As the liquid-cooled system is essentially a “closed system,” it tends to be much easier to seal to the environment making it a good solution for packs mounted external to the vehicle.

In the liquid-cooled pack, there are essentially two methods for managing the heat generation of the lithium-ion cells. In the first method, you can develop a plate that is affixed directly to the cells and flow the cooling/heating liquid directly through these plates (**Figure 6**).

The second method is to create a single plate through which the fluid flows, but rather than affix the cells directly to this plate, a series of “fins” are attached to the heat sync plate. The lithium-ion cells are then attached directly to these fins (**Figure 7**).



**Figure 6 :** Liquid cooling plates [8]



**Figure 7 :** Heat sink fins [8]

### 2.1.3 Passive Thermal Management Systems

Passive thermal management is the process of managing the temperature of the cells and the pack without forcing air, liquid, or other cooling medium into the pack. This can be accomplished through several methods. Most frequently, this is achieved through the use of aluminum or metal housings transferring the heat of the cells to an aluminum or metal pack enclosure. This allows the heat to be dispersed throughout all of the metal of the pack and enables it to radiate into the environment. This is generally referred to as a heat sync and is most effective on packs with low discharge rates as they generate less heat. Another method of passive cooling is to design the pack enclosure with fins such that as the vehicle is moving, air is forced over these fins thereby cooling the pack.

Another method of passive cooling is through the use of a phase change material (PCM). A PCM is a material that will go through multiple physical phases when heated, generally from a solid to a liquid. That is a bit of a misnomer however as the PCM does not actually become liquid, but rather it would be more accurate to say that it softens. In these designs, the PCM is generally a block of solid material, often based on wax and graphite, which is machined or molded with locations to insert the cells. As the cells heat up, the PCM absorbs the heat and disperses it throughout all the PCM causing the material to soften or melt. The PCM is an effective cooling methodology as it takes a lot of energy to force a material to go through a phase change. This can be a cost-effective solution, but it is still limited to being able to top out at a maximum temperature beyond which it will entirely melt and become ineffective as a cooling agent (**Figure 8**).



**Figure 8** : All cell phase change composite (PCC™) material [8]

## 2.2 Material Selection for Battery Pack

The material of the battery pack plays a significant role in attenuating thermal shocks, mechanical vibrations and other external loads during the ride conditions. Therefore, it is vital to select the appropriate materials to meet the functional requirements of a robust and reliable battery packaging design. It is preferred that the battery pack case, i.e. the battery pack side members and the bottom member, is fabricated from a light-weight metal, such as aluminum or aluminum alloys. A metal case ensures the rigidity or solidity required to support the weight of an assembly of cells. In addition, a metal case can adequately withstand the high temperature and pressure conditions to which a battery pack can be exposed. Furthermore, since the metals have high thermal conductivity, thermal management of the batteries would be easier. Module and pack enclosures may be designed from plastics, steel, aluminum, fiber glass, or composite materials. And in almost all cases, a combination of these materials will be used in an energy storage systems (ESS) design. **Table 1** presents some examples of the materials that are being used for battery pack cases in various EVs.

**Table 1** : Materials used for battery pack casing in various commercial cars [9]

Vehicle	Material used for battery case
Tesla Roadster	Aluminum
Honda Fit EV	Steel
Chevrolet Volt	Steel
Chevrolet Spark EV	Composite
BMW i3	Aluminum

### 2.2.1 Use of Metals in Design

- **Steel**

First, we will review the use of a stamped steel enclosure. Steel offers many benefits including high strength and relatively low cost. However, the use of a steel enclosure must also generally include some weldments or otherwise mounting attachments and may need to add mounting structures and to provide for strength. This adds to the processing time of the material and increases the cost. Several companies are today working on methods of increasing the strength and reducing the weight and mass of steel in order to make it more competitive with low-weight aluminum applications. The Nanosteel Company is one such company who offers advanced steel solutions that begin to achieve similar weight as aluminum but still retaining the high strength of steel (Nanosteel, 2014) [8].

- **Aluminum**

Aluminum enclosures can either be of stamped or die-cast methods. Aluminum offers lower weight than steel but can require additional material thickness in order to meet strength requirements, especially in stamped pieces. The other method that can be used with aluminum is



in the form of die casting. This can be either through high-pressure die casting (HPDC) which offers the best strength, porosity, and surface quality but can be very expensive to tool. Sand casting tends to be less expensive to tool but the part quality is often so low that additional finishing steps may be required. Plaster casting offers the best of both worlds, it is relatively low cost to tool and offers finishes nearly as good as the HPDC methods. The biggest challenges with plaster casting are the porosity of the flow which can create weak spots in the final product. That makes plaster casting, at least for large pieces, most beneficial as a prototype solution.

HPDC aluminum offers the benefit of being able to design a part with many features integrated into the cast itself, from mounting features to air flow channels, to structural ribs, and supports. This in addition to its low weight makes it an ideal solution for many lithium-ion battery solutions.

If the system design is based on one or more of these types of metals, then it is also important to evaluate the need for coatings. There are several reasons that you may want to use a coating and even several types of coatings. One reason to add a coating is to prevent grounding and shorting of the electronics and battery cells, in other words, to add an isolation function to the battery system. This may be available in one of several materials and types. One common usage is to use an isolating film that has an adhesive on one side. This can then be installed directly to the metal to provide the level of isolation needed. Another method for coatings is to provide either a liquid coating or a powder coating. These two methods are more often used to provide environmental protection rather than isolation.

When using metal enclosures, the design must be evaluated for strength. It is often necessary to include structural reinforcements in the enclosure. This may take the form of either additional metal components that are bolted or welded into plate, or for cast enclosures it may take the form of adding ribbing into the design. Determining which and how much reinforcement should be added should be managed through finite element analysis structural, shock and vibration management [8].

### **2.2.2 Use of Plastics and Composites in Design**

Some smaller battery systems may use plastic enclosures. These systems are more likely to use a plastic if the battery does not have major structural demands. In some of the hybrid and stop-/start-type automotive batteries, the enclosure only needs to enclose and protect the lithium-ion cells with minimum structural demands. Internal to even large battery pack, plastics and polymers are used in multiple areas. For some of the larger automotive ESSs, a composite cover may be used in concert with a metal base. For instance, General Motors Chevrolet Volt uses a sheet molded composite made of a lightweight vinyl ester resin that contains haydite nano clay filler and 40% glass fibers (Vink, 2012). In simpler terms, the cover for the Chevrolet Volt is made of fiber glass.

The Volt and its sister vehicle the Ampera use lithium-ion pouch-type cells and so also use a plastic “end” and “repeating frames” to separate each of the cells in their systems. These are injection molded plastic pieces made from BASF’s nylon 6/6 grade and Ultramid 1503-2F NAT, which is 33% glass filled and hydrolysis stabilized (LeGault, 2013).

Another component that is frequently designed with plastics is the interconnect board (ICB). The ICB is often a plastic piece that integrates the cell interconnects, wiring harnesses for temperature and voltage monitoring, electronic monitoring circuitry, mechanical support for the cells, and cell vent management. Due to the amount of functions, this may take the form of an over-molded plastic piece with copper or nickel coated copper bus bars. The GM Volt ICBs use DuPont's Zytel 7335F grade of PA6 for the base and connector housing, and a 35% glass filled PA66 by Zytel for over molding the ICB (Vink, 2012).

The other topic that should be considered in respect to plastics and polymers used in batteries is the flame retardant rating. Flame retardant ratings range from V0 to V2, the V stands for vertical flame rating but there are also horizontal flame ratings both of these sets of flame retardant ratings are based on the Underwriter's Laboratory (UL) UL-94 standard (UL Prospector, 2014). It is important to ensure that the plastics used in your ESS design are nonflammable. The reason for this is that in the event of a thermal runaway event of one or more lithium-ion cells you do not want to add more fuel to the combustion process. So if your plastics are V0 rated they will be less susceptible to the initial failure thereby making it easier to manage the cell failure [8].

## **2.3 Thermal Runaway**

Thermal runaway is the start of an exothermic chain reaction where the battery cells start to self-heat at a rate greater than 0.2 °C/min. The excessive heat generation leads to a further increase in the self-heating rate and eventually to a spontaneous combustion of chemical components forming the battery pack. A battery experiencing thermal runaway typically emits a large quantity of gas formed of hydrocarbon vapors, jets of effluent material, and sufficient heat to destroy materials in close proximity to it. Thermal runaway can be initiated by a short circuit within the cell, physical abuse, manufacturing defects, or exposure of the battery cell to extreme external temperatures. It is noteworthy that even when a heated battery is not in a state of thermal runaway, it can still vent flammable gases.

Nonetheless, the risk of any damage to property and harm to people becomes significant only after the hot gases escape the boundaries of the battery pack. The controlling factor here is the auto-ignition temperature (AIT) of the combustible hydrocarbons present in the hot gas. AIT remains relatively high as long as the gaseous materials are confined to the battery pack. However, it decreases significantly once the gas expands and comes into contact with the oxygen contained in the ambient atmosphere, potentially leading to their spontaneous combustion. It is at this juncture that the risk to property and to vehicle passengers, or to people attempting to control the event, is greatly increased.

Also, as the cells within the battery pack enter into thermal runaway, the associated pressure-rise may lead to a catastrophic failure of the battery pack enclosure. It is therefore important to include at least one failure point that has been designed to fail at a predetermined pressure in the battery packs, to avoid the risk of having an unknown point of failure which can pose a significant threat to the vehicles and their passengers.

One aspect of mitigating these risks would involve controlling the location or locations where the hot fumes and the effluent material accompanying the thermal runaway event are released. Another aspect would be to control the thermal interactions between regions of the battery pack, thereby avoiding the spread of a single thermal runaway event to the entire pack.

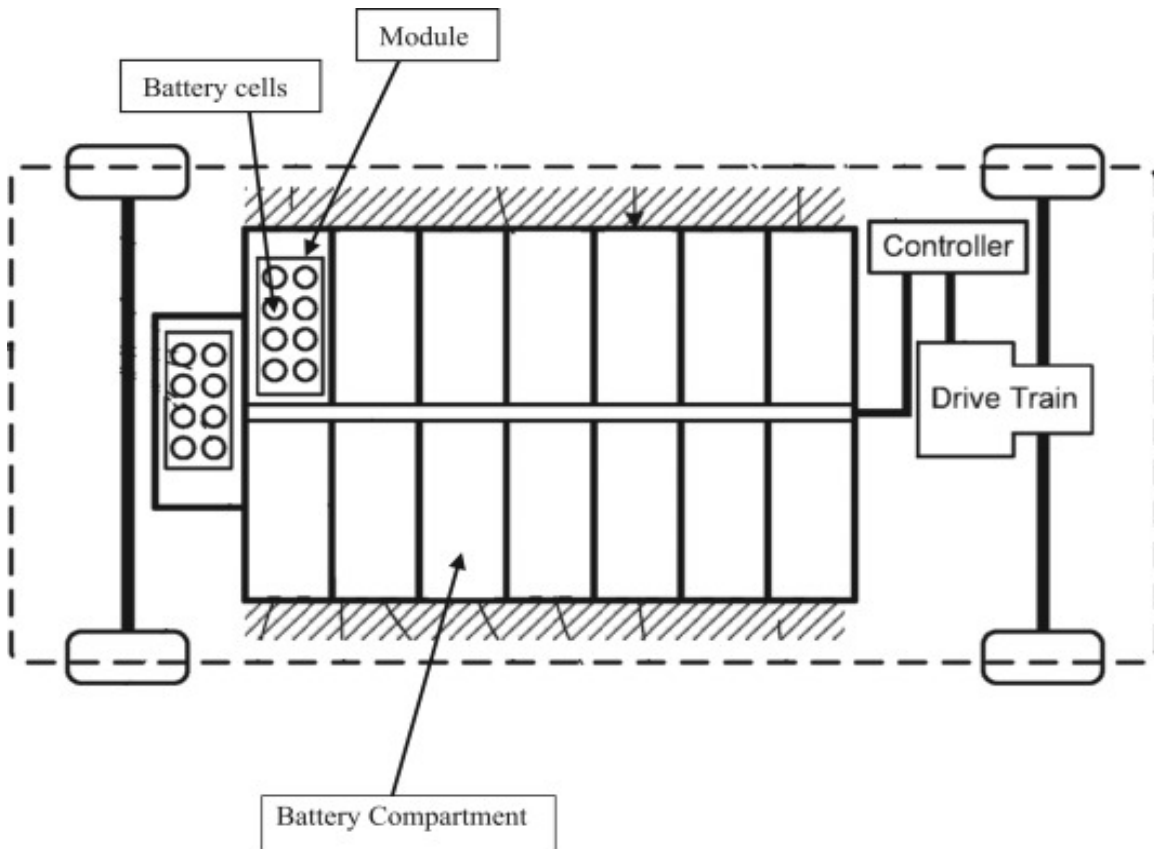
### **2.3.1 Thermal Barrier**

The increased temperatures associated with thermal runaway may cause the mounting brackets in close proximity to the battery region undergoing thermal runaway to melt or vaporize. As a result, the battery may no longer be held rigidly in its original position. As the affected battery cell/module moves, the spacing between battery components may be diminished, leading to decreased resistance to thermal runaway propagation. Battery cell/module movement may also compromise the battery pack cooling system, thus further increasing the thermal runaway propagation rate. Lastly, it should be noted that if the affected cell/module moves sufficiently, it may come to rest against an adjacent cell/module. If it does, the heat transfer process between the two regions would switch from radiation and convection to a combination of radiation, convection and thermally more efficient process of conduction. Further, in applications where a stacked-type battery configuration, i.e. a layer of battery cells arranged vertically over another layer, is used, gravitational forces may expedite the movement of the top layer once the bracket(s) begins to melt and/or vaporize. It is therefore important to restrict the movement of the battery cell or module undergoing thermal runaway to minimize the risk of thermal runaway propagation.

- **At Module Level**

US Patent No. 8663824 discloses a design in which the battery pack has been divided into a plurality of battery pack compartments by means of cross members. The packaging design as seen in **Figure 9** includes a central battery pack member which separates the left and right compartments as well as providing a convenient means for running power and data lines. As per this design, each compartment would contain just one battery module.

In the design, the lower and the upper cross-members provide a simple means of locating and holding the module in place within the battery pack by capturing the module mounting flange. Consequently, an air space is created between the modules and the top and the bottom surfaces of the battery pack. This air space insures that no conductive heat exchange would take place between two adjacent battery modules.

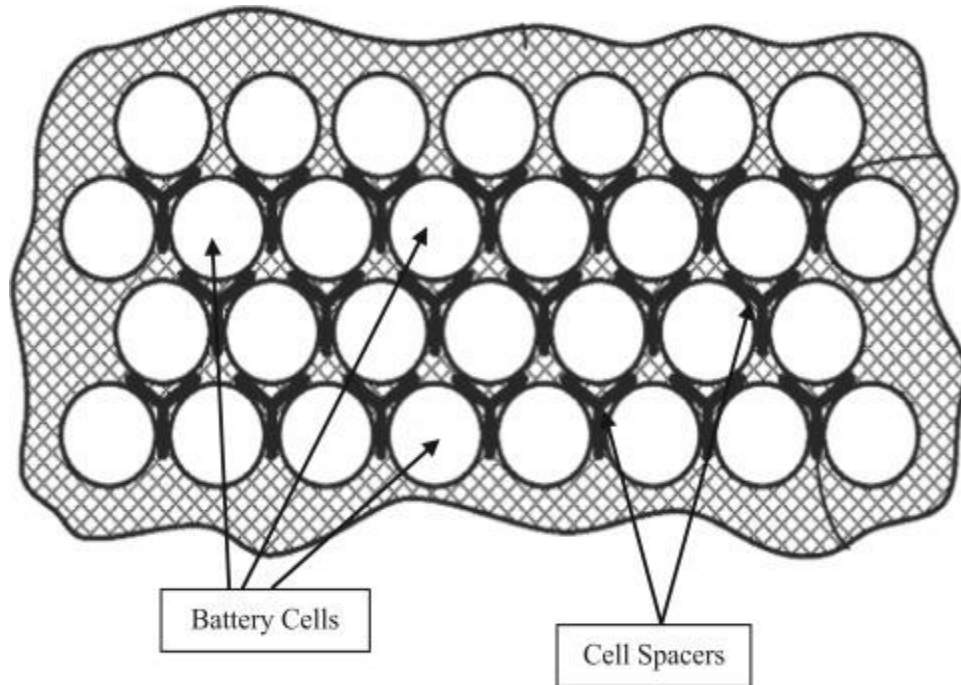


**Figure 9** : A robust battery pack with one battery module in each compartment [10]

- **At Cell Level**

The spacer assembly comprises a plurality of rigid spacers that are independent and separate from each other. These can be configured to fit between adjacent cells of the battery module, to ensure that each battery cell remains at its predetermined location. The rigid spacers may be friction fit or bonded into their place.

In general, the spacer assembly selected for integration within the cell mounting bracket depends on the type and shape of the cells employed within the battery pack. US Patent 8481191 provides a design of a spacer assembly for use with a cylindrical battery cell in a battery pack as seen in **Figure 10**. Each of the spacers has a height between 1% and 5% of the overall battery height.



**Figure 10** : A cylindrical battery cell assembly with cell spacers [11]

## 2.4 Vibration Isolation

Conventional battery pack structures are not designed to isolate transmission of undesirable vibrations to the assembled battery cells. Accordingly, the frequency of vibrations transmitted from the top portion of the vehicle to the battery pack structure, mounted in a vehicle can be approximately equal to or less than 100 Hz [12]. As a result, dynamic mechanical loads develop on the electrical subsystems such as terminal connectors and bus bars in a battery pack, which can effect in loss of electrical continuity and fatigue failure of the casing. In fact, lack of proper vibration isolation of electrical and electronic subsystems has been cited as the primary cause of in-market durability failures of battery packs. However, a far graver problem than the loss of electrical continuity arises when natural frequency of the battery structure lies within a frequency range of 100 Hz. The resonance causes an interlayer delamination between the elements of the battery cells to occur wherein the respective layers forming the battery cell disassociate from one another, which is one of the main reasons for the reduced cycle life of the battery [13].

## 2.5 Battery Pack Placement

For the purpose of effective space utilization in an EV, it is necessary that the batteries be placed in a space which is otherwise unused. From a vehicle dynamics point of view, the battery pack should be positioned in such way that the center of gravity of the vehicle remains low and

mechanical stresses and fatigue on mounting frame are minimized. From a thermal perspective, the battery pack should be placed where an appropriate air circulation to maximize the heat dissipation is possible. To address the issue of electrical safety, the battery pack should be treated as a primary component of the electric drivetrain, similar to the engine of an internal combustion engine vehicle. It should hence be located outside the passenger compartment so that the high voltage components do not pose any threat to the passenger safety.

Also, the battery pack should be spaced apart from the front or the rear end of the vehicle structure in order to protect the battery from potential impacts. An ideal space for such storage is in the center of the vehicle beneath the vehicle floor, but because of the limited ground clearance in passenger vehicles, any such support structure must be carefully designed to use the available space for maximum effectiveness. **Table 2** shows the size of the battery packs available in different state of the art commercial cars and their location with respect to the vehicle chassis.

**Table 2** : Battery pack and its location in some state of the art commercial cars [9]

Vehicle	Chemistry	Size (kWh)	Electric range (km)	Battery location
<b>Bolloré Bluecar</b>	Lithium-ion	30	250 (City)	Center
	Polymer		150 (Highway)	
<b>BMW i3</b>	Lithium-ion	18.8	130-160	Center
<b>Nissan Leaf</b>	Lithium-ion	24	121 (EPA)	Center
			200 (NEDC)	
<b>Ford Focus Electric</b>	Lithium-ion	23	122 (EPA)	Rear
<b>Tesla Model S</b>	Lithium-ion	60	335 (EPA)	Center
		85	426 (EPA)	
<b>BYD e6</b>	Lithium-ion	61.4	300	Center
<b>Fiat 500e</b>	Lithium-ion	24	140 (EPA)	Rear
<b>Toyota RAV4 EV</b>	Lithium-ion	35	166 (EPA)	Center
<b>Chevrolet Spark EV</b>	Lithium-ion	21.3	132 (EPA)	Rear
<b>Volkswagen e-Golf</b>	Lithium-ion	24.2	190 (NEDC)	Center
<b>Mitsubishi I MiEV</b>	Lithium-ion	16	100 (EPA)	Center

\* Bracketed term indicates drive cycle

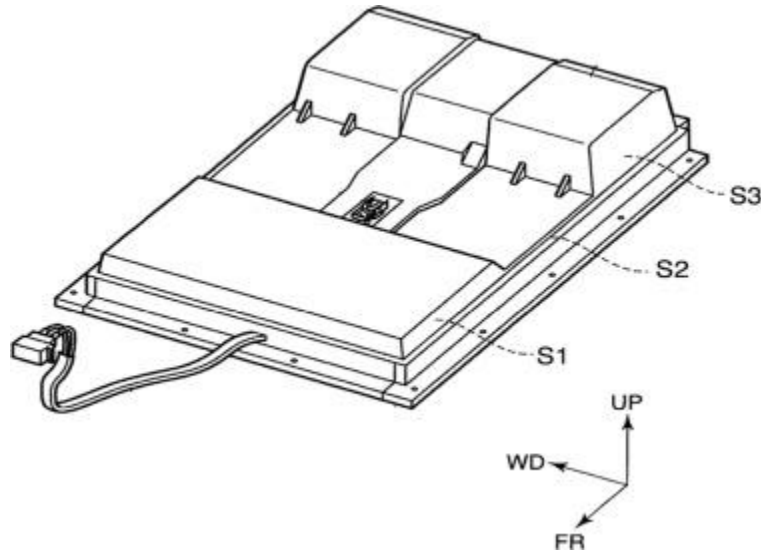
EPA = Environmental Protection Agency

NEDC = New European Driving Cycle

US Patent 8561743 discloses a method to place as many batteries as possible on the EV in the central location without affecting the vehicle dynamics or safety. The patent discloses a battery assembly design in which a group of batteries S1 is located below the front seats, another group S2 is located under the floor between the front and the rear seat, and finally a group of batteries S3 is located below the rear seat.

In groups S1 and S2, the batteries are stacked in a vertical direction such that the long side is oriented in the vehicle transverse direction and the short side is oriented in the longitudinal

direction of the vehicle, whereas in group S3, the batteries are stacked such that the shortest side is oriented in the vehicle transverse direction. Depending upon the width of the lower part of the vehicle body, the number of batteries stacked or the length of the group S3 in the vehicle transverse direction can be minutely adjusted, thus using the space under the rear seat efficiently and placing a large number of batteries on-board. **Figure 11** presents a general design layout of prismatic Lithium-ion battery cells in a Nissan LEAF battery pack.



**Figure 11** : Nissan Leaf battery pack [14]

Furthermore, assuming that the height of group S1 is  $h_1$ , the height of group S2 is  $h_2$ , and the height of group S3 is  $h_3$ . Then, by making the height  $h_1$  and the height  $h_3$  greater than the height  $h_2$ , space under the seats can be utilized more efficiently, and a higher number of the batteries can be placed in the vehicle without affecting space availability for the passengers. Also, as per this layout, the height  $h_3$  is made greater than the height  $h_1$ . Consequently, the sitting level of the rear seat becomes higher than the sitting level of the front seat. This arrangement is preferable as it provides a wide viewing angle for the passengers in the rear seat [14]. **Figure 12** helps to visualize the sitting level and the better angle of view available for rear passengers achievable through this design configuration.



**Figure 12** : Placement of lithium ion battery pack in Nissan Leaf [15]

In view of making effective use of the cabin space and to improve safety in a collision, the battery pack is placed under the seats on the inner cabin side of the floor panel. However, in conventional vehicles, the seats are usually mounted via a mounting fixture on a seat rail for adjusting the available leg space in the vehicle body. As a result, access to the battery pack becomes restricted and if battery pack maintenance or replacement operations are to be performed, the rear seat and seat rails needs to be temporarily removed, rendering the task difficult and inefficient.

Lastly, the battery pack is placed in the center of the chassis under the passenger seats such that it is able to serve as a semi-structural element of the vehicle structure. At the same time, it is always kept away from the usual crash zones of the vehicle i.e. the front and the rear. This strategic placement of the battery pack in the Chevrolet Volt allows it to contribute to the 25 Hz bending stiffness of the vehicle body and ensures minimum damage to battery cells in a crash event, resulting in higher crash-worthiness of the vehicle [16], [17].

## **3 General Concept**

### **3.1 Concept From Patent Research**

The traditional procedures of the innovation process are usually followed in the following steps: decomposition and formulation of innovation problems - creative problem solving - synthesis of partial solutions. However, completely new technical solutions are not easy to implement in practice because many related issues must be addressed. Innovative modern science is therefore carried out much more intensively after formulating the innovation problem activities aimed at exploring known and described solutions on how functions can otherwise be performed related to the problem.

"Infinite" information sources in Cyberspace (available information from the market, patent databases, professional and scientific articles, etc.) are available for this solution task. Finding solutions in Cyberspace have at least two advantages. Firstly, the answer found is usually an existing technology. Secondly, it is possible to use appropriate procedures to discover solutions even in very remote fields areas of science and technology. Suppose a suitable solution is found in another field. In that case, the nature of the innovation problem fundamentally changes to the adaptation problem, which is easier to overcome than the problem of "inventing" new solutions. It's a more straightforward and reliable procedure that needs fewer resources (time, labor, capital).

An essential source of information is patent documents, which contain helpful know-how, exceeding the knowledge of a more self-talented technician working on analogies or deductive procedures. Patent research is mainly about searching the information related to information that forms an integral part of the industrial law field, especially in terms of the world of technology, and also those that may impact one of the essential criteria - the novelty of the technical solution.



The following methods and tools were used for the search:

- Creating queries in the form of keywords
- Boolean logic operators
- Querying in the ESPACENET patent database
- Querying in the USPTO database
- Querying in the WIPO
- Querying in the Patent Inspiration
- Querying in the Google Patents
- Querying in the Global Dossier
- Querying in the Google Scholar
- Web pages of manufacturers and users of the subject of the search

### **3.1.1 Defining Search Queries**

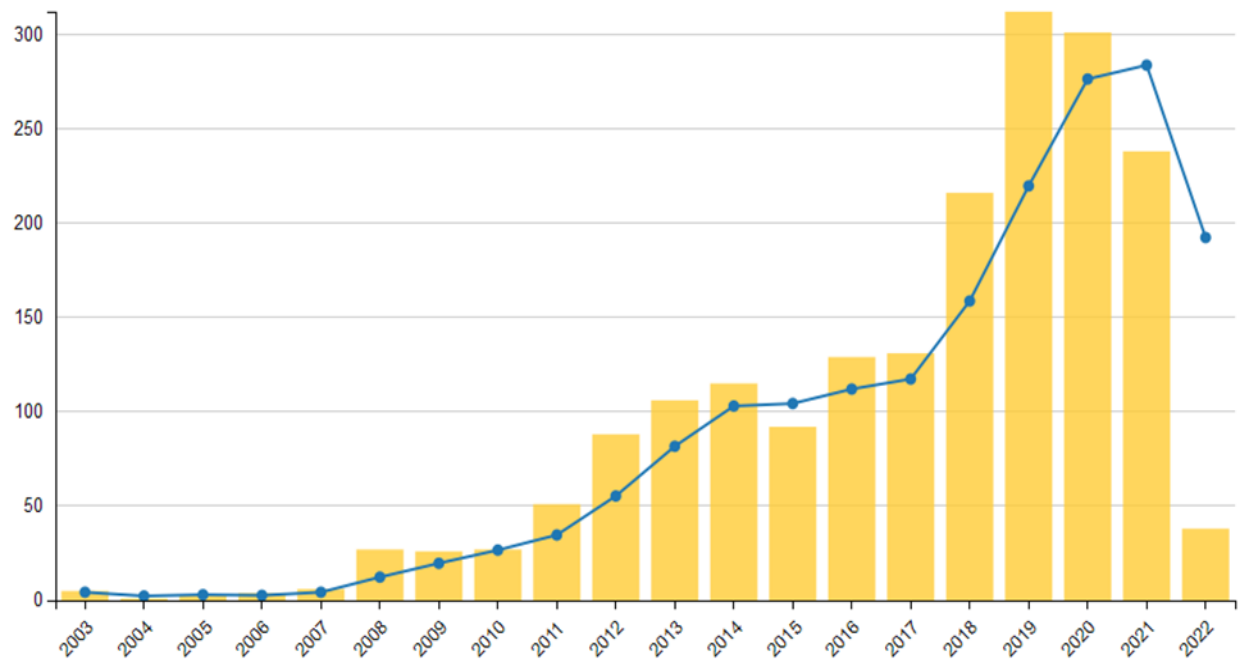
Various keywords related to components or the entire technical system on the specified innovation assignment, as well as combinations using Boolean logic, were used for searching in information databases, such as:

- „BATTERY BOX“ AND (ELECTRIC) VEHICLE
- „BATTERY CASE“ AND (ELECTRIC) VEHICLE
- „BATTERY SHIELD“ AND (ELECTRIC) VEHICLE
- „BATTERY PACK“ AND (ELECTRIC) VEHICLE
- „BATTERY PACK ENCLOSURE“ AND (ELECTRIC) VEHICLE
- „BATTERY BOX“ AND MATERIAL
- „BATTERY BOX“ AND DESIGN
- „BATTERY ENCLOSURE“
- „BATTERY MODULE HOUSING“

### **3.1.2 Patent Databases Focused on Battery Box Innovation for Electric Car**

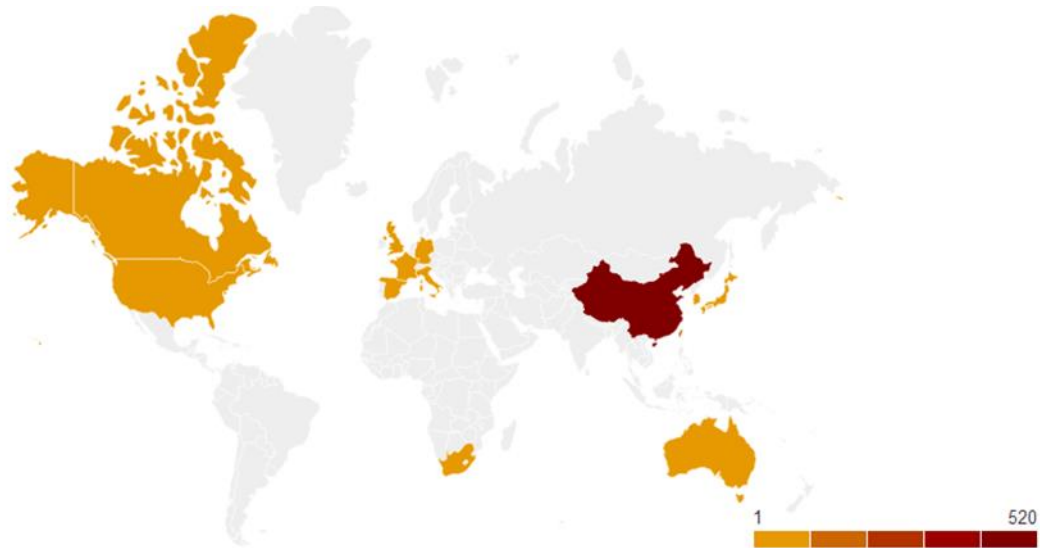
This part presents the survey results (always considered 1 document per patent family). This was the case for these search queries (QUERY):

- „BATTERY PACK“ AND (ELECTRIC) VEHICLE Identified **7551 documents**
- „BATTERY BOX“ AND DESIGN Identified **2791 documents**
- „BATTERY BOX“ AND MATERIAL Identified **1979 documents**
- „BATTERY BOX“ AND (ELECTRIC) VEHICLE Identified **1981 documents**
- „BATTERY CASE“ AND (ELECTRIC) VEHICLE Identified **710 documents**
- „BATTERY ENCLOSURE“ Identified **382 documents**
- „BATTERY MODULE HOUSING“ Identified **257 documents**
- „BATTERY PACK ENCLOSURE“ AND VEHICLE Identified **11 documents**
- „BATTERY SHIELD“ AND (ELECTRIC) VEHICLE Identified **2 documents**



**Figure 13** : Number of patent documents over time (QUERY: "BATTERY BOX" AND VEHICLE, 1981 documents, 1 per patent family) [18]

The responses that provided the optimal number of retrieved documents were analyzed in more detail. Examples of selected relevant technical solutions are given in the following section. The following are the abstracts of identified current and relevant patent documents obtained by the query "BATTERY BOX" AND (ELECTRIC) VEHICLE.



**Figure 14** : Geographical analysis of applicants for patent documents (QUERY: "BATTERY BOX" AND VEHICLE, 1981 documents, 1 per patent family) [18]

### 3.1.3 Document CN213782095U

#### Battery Device and Electric Motor Car with Heat Dissipation Function

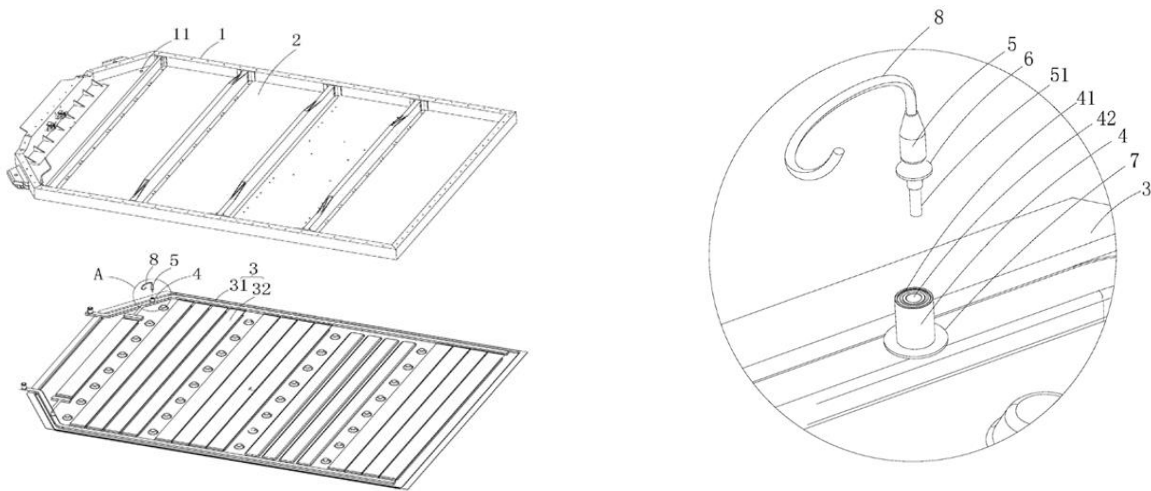
##### Abstract

With the development of new energy technology, the energy density of the battery device is continuously increased, the requirement of the liquid cooling system of the battery device is also continuously increased, and the liquid cooling system is separated from a high-voltage area and highly integrated to form a trend of technical development based on the requirement on the safety of the battery device. However, the prior art mainly arranges the temperature sensor at the position of the main water inlet and outlet outside the box body of the battery device or arranges the temperature sensor between the liquid cooling plate and the partition plate, and the two arrangements have the following defects:

1. When the temperature sensor is arranged outside the box body, the working environment of the sensor is severe, and risks of corrosion, mechanical damage and artificial damage are easy to occur;
2. When the temperature sensor is arranged outside the box body, the acquisition wiring harness of the temperature sensor still needs to extend into the box body to be connected to the battery management system, and the direction and the structure of the acquisition wiring harness are complex;
3. When the temperature sensor is arranged between the liquid cooling plate and the partition plate, more longitudinal space of the battery device is occupied;

4. When the temperature sensor is arranged between the liquid cooling plate and the partition plate, the temperature sensor is difficult to disassemble, assemble and inspect when damaged;
5. When arranging temperature sensor between liquid cooling board and baffle, because of blocking of box baffle, it is comparatively complicated to gather trend and structure that pencil and the inside battery management system of box are connected.

To more clearly illustrate the technical solutions in the embodiments of the present invention, the drawings needed to be used in the embodiments will be briefly described below. The drawings in the following description are only some embodiments of the present invention. It is obvious for those skilled in art that other drawings can be obtained according to these drawings without creative efforts.



**Figure 15** : Document CN213782095U [19]

1-box body, 2-battery module, 3-heat dissipation assembly, 4-mounting a structure, 5-temperature sensor, 6-first gasket, 7-second gasket, 8-cable, 11-perforating, 31-liquid cooling pipes, 32-liquid cooling plate, 41-sealing boss, 42-a threaded hole, 51-fastener.

### **3.1.4 Document US2021323418A1**

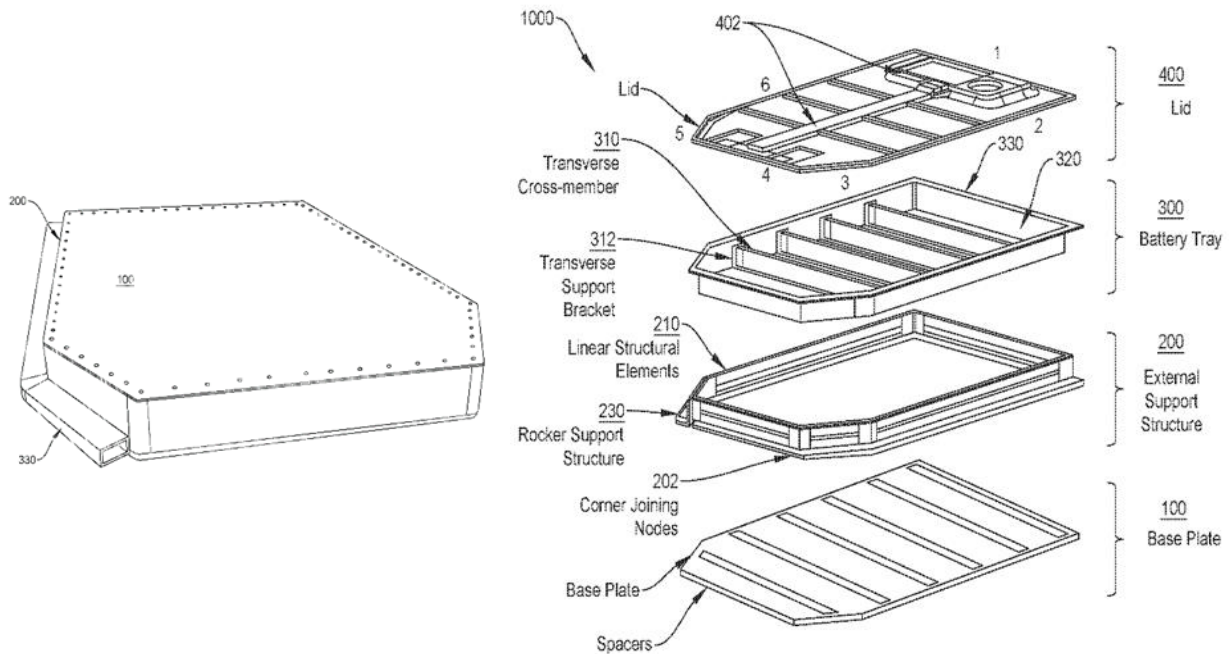
#### **Composite Battery Enclosure**

##### **Abstract**

A battery enclosure for a vehicle chassis comprising a base plate having an upper and lower surface and a plurality of edges; an external support structure with a flange portion on a lower surface thereof and disposed on an upper surface of the base plate to circumscribe the base plate edges; a battery tray with a flange portion extending from an upper surface thereof is disposed on an upper surface of the base plate. The battery tray includes a plurality of raised surface features on the

upper surface outlining individual cells, each cell configured to receive at least one battery. A lid is disposed on the flange of the battery tray with the external support structure disposed below the battery tray flange and extending around the battery tray edges.

A detailed description of various aspects, features, and embodiments of the subject matter described herein is provided with reference to the accompanying drawings, which are briefly described below. The drawings are illustrative and are not necessarily drawn to scale, with some components and features being exaggerated for clarity. The drawings illustrate various aspects and features of the present subject matter and may describe one or more embodiment(s) or example(s) of the present subject matter in whole or in part.



**Figure 16** : Document US2021323418A1 [19]

### 3.1.5 Document US2021305544A1

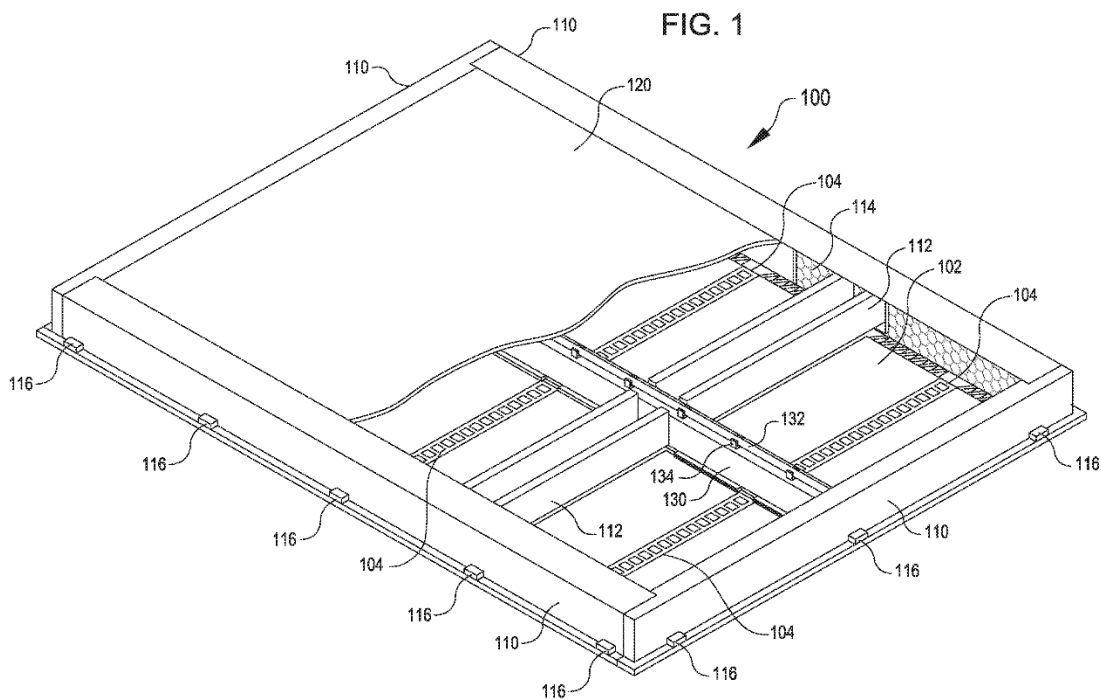
#### Battery Enclosure

##### Abstract

A battery enclosure and manufacturing method are the same as organ sheet materials. The battery enclosure includes a top cover with crossbeams integrated therein by over-molded that secures to a bottom panel to enclose a space for containing components of a battery. The bottom panel includes over-molded structural ribs to provide strength and rigidity to the bottom panel. An outer cover removably secures the top cover to the bottom panel and consists of a honeycomb structure to crush upon impact and protect the battery components. The method comprises forming each

component of the battery enclosure from a mixture of organ sheets, reinforcing members, and over-molded elements to reduce the weight and complexity of manufacturing the battery enclosure.

Turning to **Figure 17**, a perspective view of a battery enclosure 100 formed of organ sheets is shown with a portion of a top cover 120 cut away. The battery enclosure 100 defines an inner cavity to enclose cells of a battery for powering a vehicle system, such as an electric vehicle. The battery enclosure 100 may fit within a battery compartment of the electric vehicle. Though the battery enclosure 100 is described with respect to a battery for powering the operation of an electric vehicle, the description included herein will be understood by those with skill in the art to be applicable to other types of devices powered by batteries, including consumer electronics, vehicles, toys, tools, and other such powered devices.



**Figure 17** : Document US2021305544A1 [19]

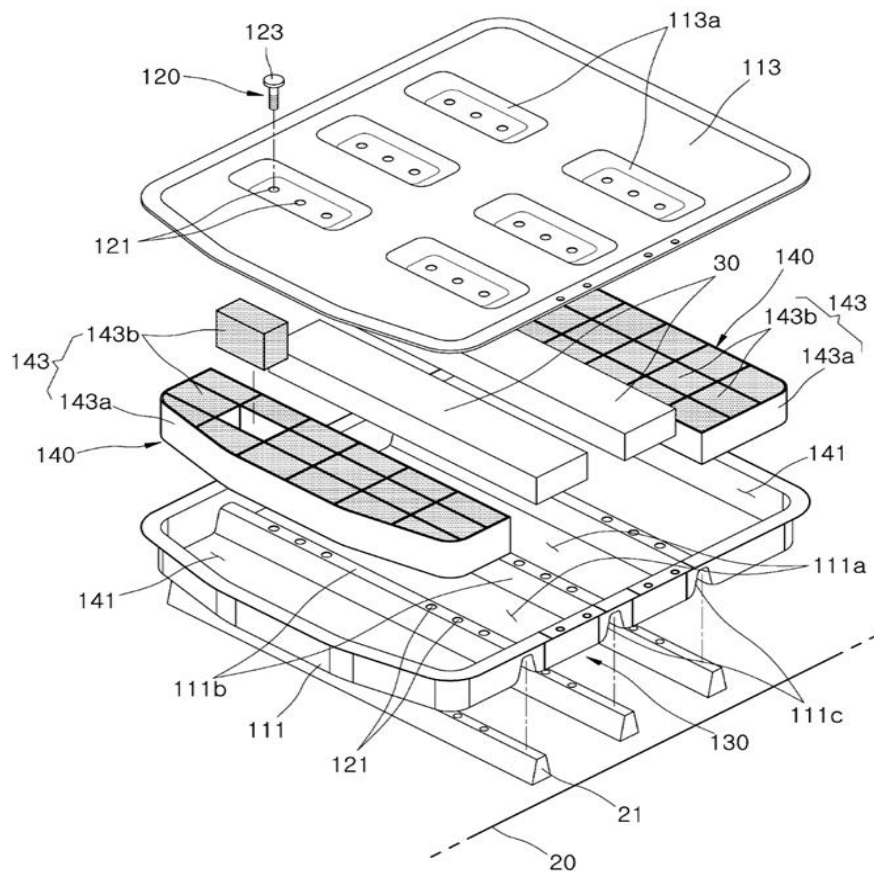
112-the crossbeams, 130-longitudinal beam may include connections 134 for wires 132, 116-attachment members, 114-honeycomb structure, 102-bottom panel, 104-structural ribs, 110-the outer covers.

### 3.1.6 Document KR20210036205A

#### Battery Case for Electric Vehicle

Abstract

Disclosed is a battery case apparatus for a battery-detachable electric vehicle. The disclosed battery case apparatus for a battery-detachable electric vehicle comprises a battery case coupled to a vehicle body and having a plurality of battery installation space units in which battery cells are installed, a case body fixing unit connected to the vehicle body by passing through the battery case to fix the battery case to the vehicle body, a battery attaching and the detaching unit provided in the battery case to be connected to and detached from the battery case, and a shock absorption buffer unit provided in the battery case to absorb an external shock. An objective of the present invention is to provide the battery case apparatus for a battery-detachable electric vehicle that can improve shock resistance by preventing the battery cells from being damaged even when an external shock deforms the battery case by forming the shock absorption buffer unit in the battery case.



**Figure 18** : Document KR20210036205A [19]

10-electric vehicle, 20-body, 21-support beam, 30-battery cell, 100-battery case device for battery detachable electric vehicle, 110-battery case, 111-case body, 111a-battery installation space, 111b-bulkhead, 111c-beam support groove, 113-main body cover, 113a-recessed contact portion, 120-case body fixing portion, 121-through-hole part, 123-fastening ball part, 130-battery detachment part, 131-battery detachment opening, 133-opening and closing door, 135-door fixing material,





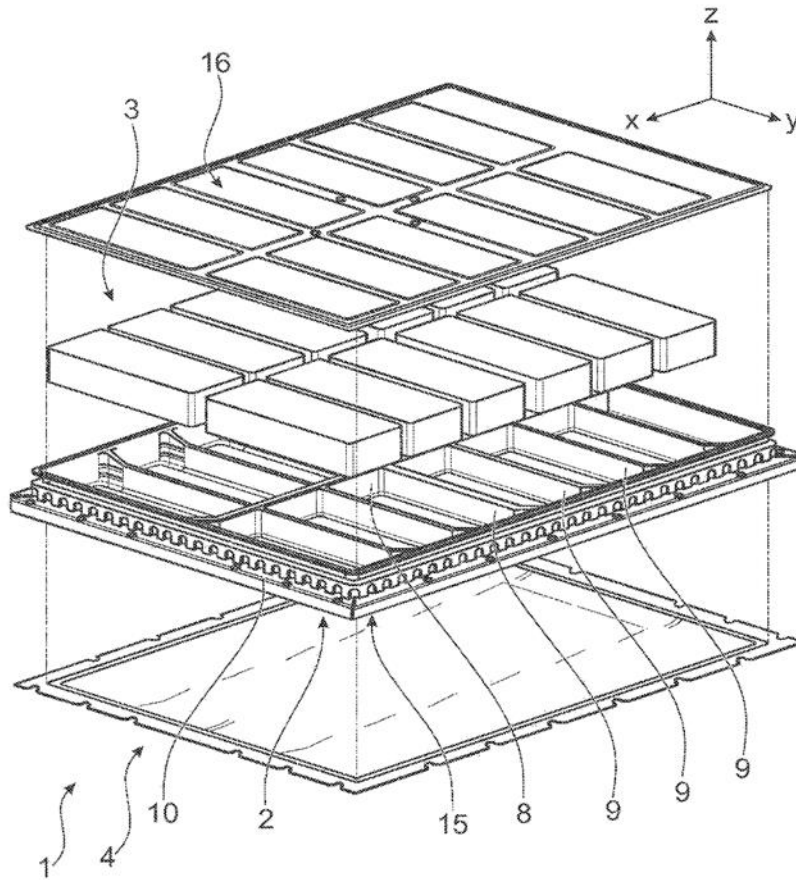
20-cover, 34-through hole, 32-periphery, 40-peripheral portion, 36-protrusion part, 35-inner bottom part, 56-edge, 50-opening face of the recess, 24-the frame, 28-attachment brackets, 54-fastening portion, 48-fastening portion, 42-periphery, 44-through-holes, 46-outer circumferential wall, 52-edge.

### 3.1.8 Document US2021260978A1

#### Battery Structure and Protector

##### Abstract

The present disclosure relates to a battery structure for an electric vehicle. The battery structure comprises a battery case for at least one battery module, and a protector, including a top belt, a bottom belt, and a core arranged between and interconnecting the top belt and the bottom belt. The top belt has a wavelike cross-section. The described invention herein will be more fully understood from the detailed description below and the accompanying drawings, which should not be considered limiting to the invention described in the appended claims. The drawings show:



**Figure 20** : Document US2021260978A1 [19]

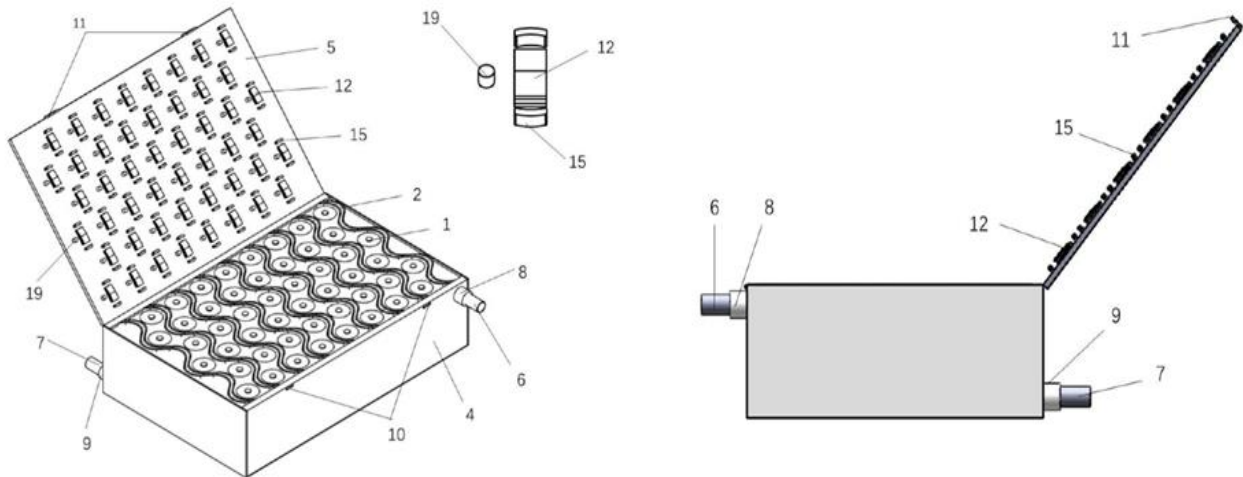
1-battery structure, 2-battery case, 3-battery module, 4-protector, 8-longitudinal beams, 9-transverse beams, 10-frame.

### 3.1.9 Document CN113314783A

#### Electric automobile battery temperature management system based on composite phase change material and liquid cooling are mixed

Abstract

The embodiment of the invention discloses a liquid cooling and composite phase change material mixing-based battery temperature management system for an electric vehicle, comprising composite phase change material, battery box, and heat transfer system. The lithium-ion battery columns are arranged in the battery box body in a layered and staggered manner, vertical snake-shaped three-layer hollow metal plates are arranged among layers, and the outer layer is a phase-change material-filled shell layer; the middle layer is a heat exchange fluid passage and is communicated with the corresponding hollow box wall. The battery temperature management system carries out temperature monitoring through the temperature sensor near the electrode, can transmit real-time temperature to the vehicle-mounted electronic control unit ECU (electronic control Unit), and can further carry out heat preservation treatment on the battery through the heat exchange system when the temperature of the battery is too high or too low, so that the battery is in a constant temperature range, and has a broad application prospect. The main technical characteristics of this patent product are embodied: the heat conduction efficiency is high, the temperature distribution is even, and the temperature control effect is stable.



**Figure 21** : Document CN113314783A [19]

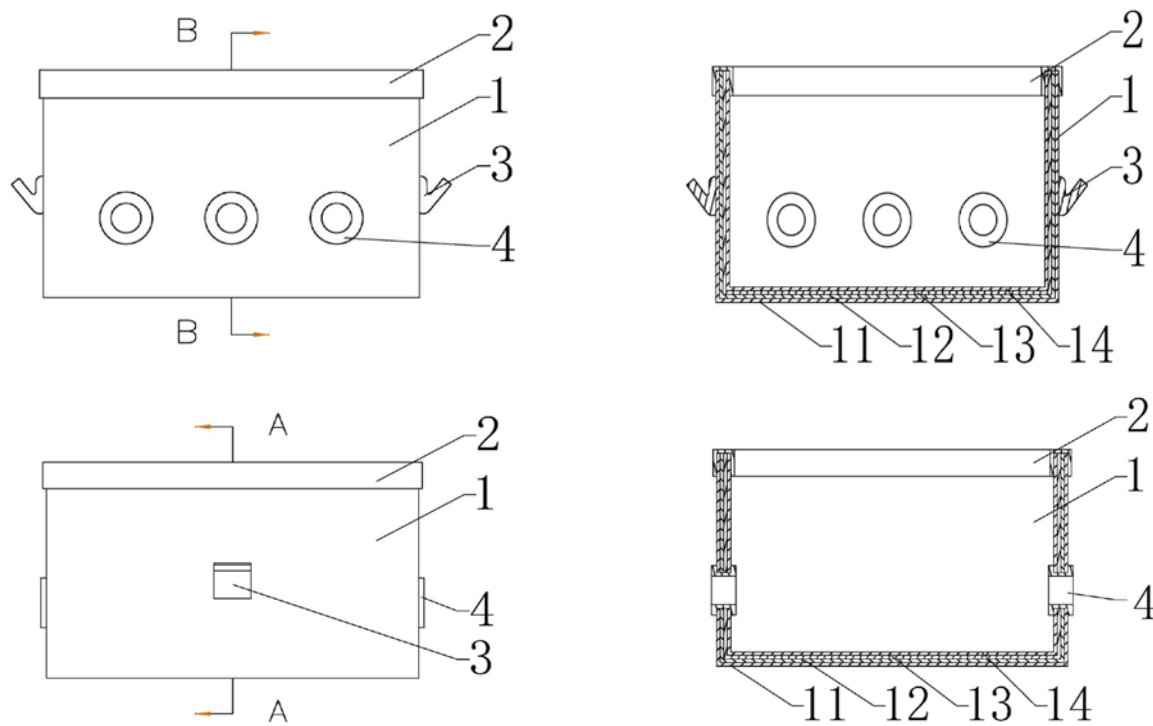
1-the device comprises a lithium ion battery column, 2-heat conduction pipeline, 4-battery box body, 5-battery box cover, 6-water outlet pipe, 7-water inlet pipe, 8-water outlet, 9-water inlet, 10-box body buckle, 11-box cover buckle, 12-box cover elastic metal sheet, 15-box cover clamping groove, 19-temperature monitoring device.

### 3.1.10 Document CN213936386U

#### Insulating Battery Box of Electric Vehicle

##### Abstract

The utility model provides an electric vehicle insulation battery box, which comprises a box body, wherein the box body is equipped with a waterproof layer, a heat insulation layer, a reinforcing layer, and an insulation layer from outside to inside, a box cover is arranged above the box body, and a guide tube and a conducting strip are arranged on the side surface of the box body; the utility model discloses a box body can play damp proofing, thermal-insulated effect through having set up multilayer structure, in case battery store takes place to leak simultaneously, also can keep apart and lead.

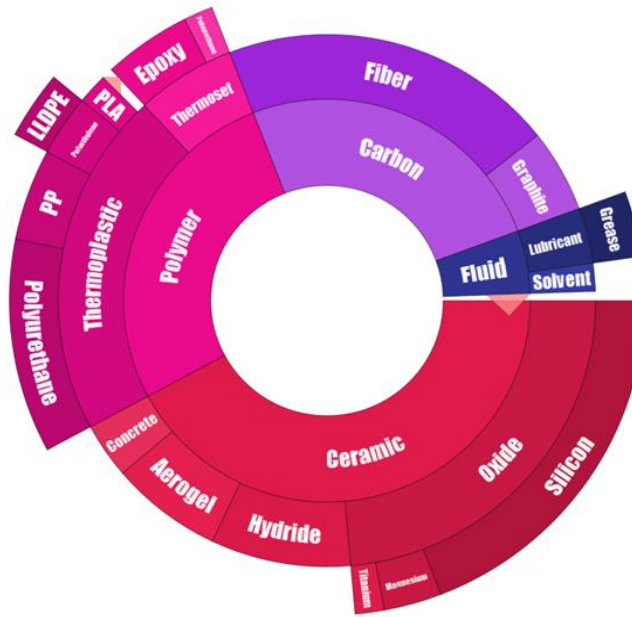


**Figure 22** : Document CN213936386U [19]

1-box body, 2-box cover, 3-conductive sheet, 4-guide tube, 11-a waterproof layer, 12-a thermal insulation layer, 13-reinforcement layer, 14-an insulating layer.

### 3.1.11 Materials Cited in Patent Documents

With the help of semantic analysis, we also identified other information for creating innovation tasks. **Figure 23** is an overview of the materials cited in the patent documents.



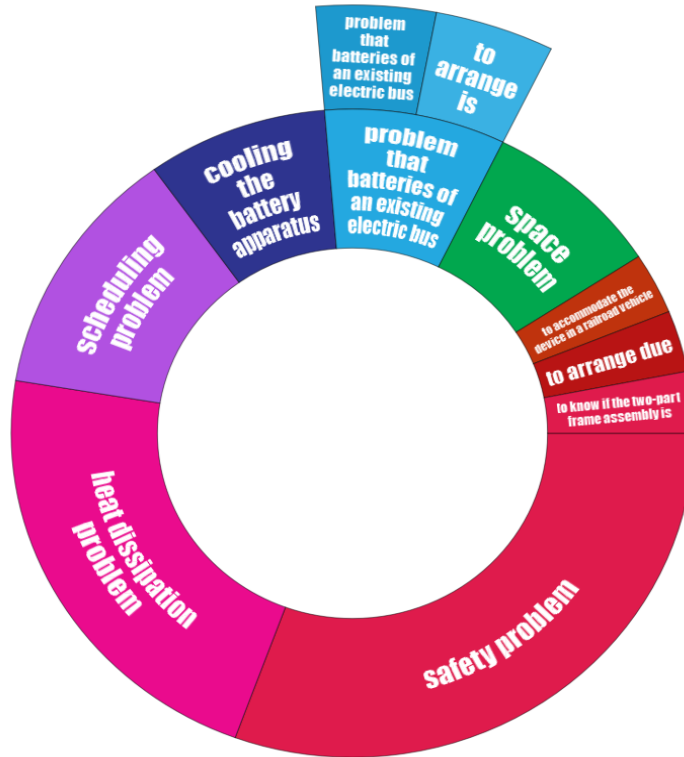
**Figure 23 :** Materials cited in patent documents (QUERY: "BATTERY BOX" AND VEHICLE, 1981 documents, 1 per patent family) [18]

<b>Ceramic (43)</b>	<b>Polymer (41)</b>	<b>Carbon (39)</b>	<b>Metal (16)</b>
Oxide (25)	Thermoplastic (38)	Fiber (26)	Non-Ferrous (11)
Silicon (22)	Polyurethane (11)	Graphite (8)	Magnesium Alloy (7)
Magnesium (4)	Vinyl (10)	Diamond (4)	Copper Alloy (4)
Titanium (4)	PP (8)	Black (2)	Brass (4)
Calcium (1)	Silicone (5)		Aluminum Alloy (1)
Aluminum (1)	Polyethylene (3)		5000 Series (1)
Hydride (8)	LLDPE (3)	<b>Fluid (10)</b>	Ferrous (3)
Aerogel (6)	HDPE (1)	Lubricant (5)	Carbon Steel (2)
Clay (2)	MDPE (1)	Grease (3)	Low (2)
Concrete (2)	Polyester (3)	Oil (2)	Tool Steel (1)
Halide (1)	PBT (2)	Synthetic (2)	Cold Work (1)
Nitride (1)	PET (2)	Silicon (2)	Foam, Mesh or Honeycomb (3)
High Temperature (1)	PPA (2)	Solvent (4)	Intermetallic Steel (1)
Carbide (1)	PPO (1)	Quenchant (1)	
	PLA (1)		
	Polycarbonate (1)		
	PEI (1)		
	Polyolefin (1)		
	Ethylene Vinyl Alcohol (1)		
	Ethylene Vinyl Acetate (1)		
	PEEK (1)		
	PAA (1)		
	Elastomer (1)		
	Styrenic (1)		
	Thermoset (7)		
	Epoxy (6)		
	Phenolic (2)		
	Polyester (2)		
	Polyurethane (1)		
	Vinyl Ester (1)		

**Figure 24 :** Number of patent documents for each material [18]

### 3.1.12 Problem Areas Cited in Patent Documents

In **Figure 25**, we can find out more information about the problem areas in manufacturing battery boxes for electric vehicles.



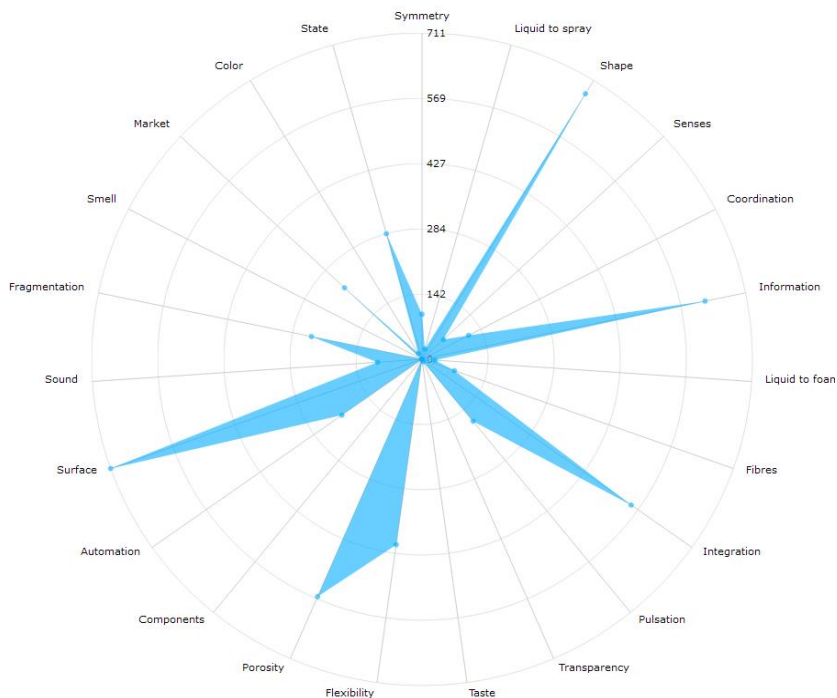
**Figure 25** : Problem areas cited in patent documents (QUERY: "BATTERY BOX" AND VEHICLE, 1981 documents, 1 per patent family) [18]

Problem	Patents
cooling the battery apparatus	3
heat dissipation problem	8
problem that batteries of an existing electric bus	3
safety problem	15
scheduling problem	4
space problem	3
to accommodate the device in a railroad vehicle	2
to arrange due	2
to arrange is	3
to know if the two-part frame assembly is	2

**Figure 26** : Number of patent documents for each problem [18]

### 3.1.13 Evolutionary Potential Analysis Cited in Patent Documents

The evolutionary potential analysis maps the standard properties of a patent pool. Every property is backed up with a list of synonyms and software extracts, which properties are described most in the patent text, and which properties still need to be explored. This analysis can help us to visualize the plot, shows the current properties of our patent pool, and the potential for variation still left open.



**Figure 27** : Evolutionary potential analysis in patent documents (QUERY: "BATTERY BOX" AND VEHICLE, 1981 documents, 1 per patent family) [18]

Analysis shows that the most current properties in the patent text are: Shape, Information, Integration, Flexibility, Porosity, and Surface. So the innovation potential in the case of electric vehicle battery boxes still left are:

- **Pulsation**
- **Automation**
- **Symmetry**
- **Fiber**
- **Transparency**
- **Fragmentation**

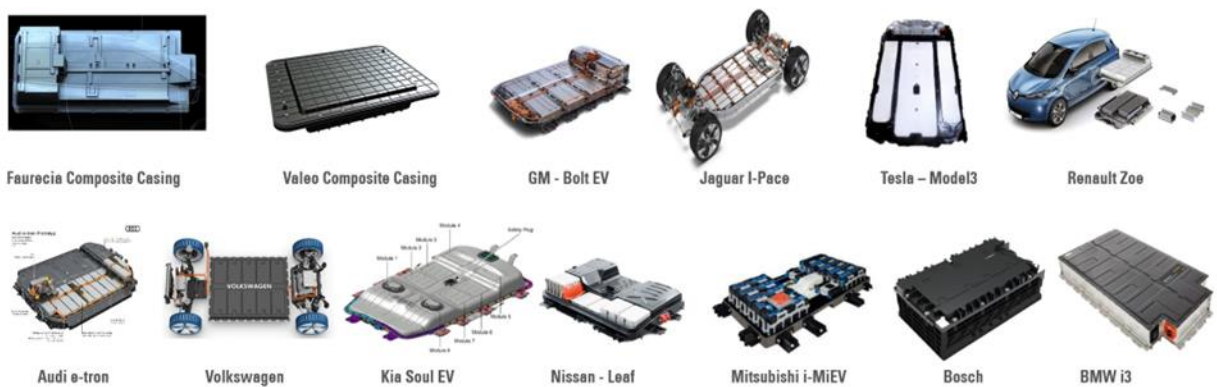
### 3.2 Concept From Non-Patent Research

In addition to searching in open and commercial databases, we can use sources of information such as a simple number of search results in the Google engine that were used in non-patent research.

**Table 3 :** The number of responses to selected terms in the Google search engine

Term (Query)	Number of responses (Google)
„BATTERY PACK“	44 900 000
„BATTERY CASE“	10 400 000
„BATTERY BOX“	12 100 000
„BATTERY ENCLOSURE“	279 000
„BATTERY PACK ENCLOSURE“	14 700
„BATTERY MODULE HOUSING“	3 410

Several commercial and technical solutions have been identified in open sources.



**Figure 28 :** Current technical solutions for battery boxes [20]

We also used the deep web (invisible net) to assess innovativeness, searching for relevant information in the non-patent research. Non-patent research, as the term suggests, consists of documents that are not patented, such as professional journals and scientific proceedings. In some technology areas, the non-patent research includes a larger volume of prior information than patent documents. Among such databases focused on non-patent research, we can find freely accessible commercial and paid databases.

The sources of the information from non-patent research below will include:

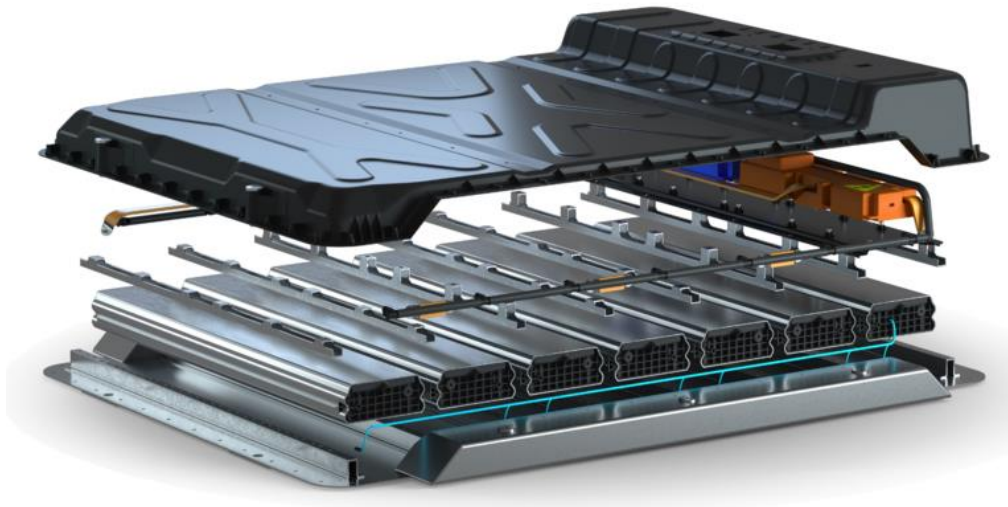
- The identified direction of innovation,
- Source of information,
- Characteristics of the innovation.

### 3.2.1 Multi-Material Battery Enclosure From LION Smart

While most automotive manufacturers have started to shift focus away from combustion engine vehicles and invest heavily into development of EV's, there are still no global standards for production of individual components. Together with consortium partners Evonik, Forward Engineering, Lorenz Kunststofftechnik, and Vestaro (a joint venture of Evonik and Forward Engineering), LION Smart assisted development of a modular-multi-material approach to battery housing production that aims to address these issues. Combined expertise resulted in a brand-independent, cost-effective composite solution that reduces the weight of the battery housing unit by approximately 10 percent compared to other common material combinations on the market, while maintaining mechanical and structural integrity.

The project utilized super cell concepts from LION Smart inside the new battery enclosure to create a cost-effective, lightweight and high voltage cell to pack system. Individual cells are enclosed in a non-flammable dielectric coolant. This also ensures a constantly low average temperature within the battery, which benefits cell aging. The battery housing utilizes a fiberglass Sheet Molding Compound (SMC) based on high-performance epoxy curing agent VESTALITES from Evonik to deliver the same effectiveness of metal-based battery enclosures – but in a significantly lighter package.

The glass-fiber-reinforced epoxy SMC has excellent mechanical properties including flexural and impact strength, and by using epoxy resin instead of the usual polyester resin, other problems often encountered during downstream processing of glass-fiber-reinforced SMC materials have been eliminated. Additionally, it meets all specifications regarding fire resistance and is easy to process even when complex geometries are demanded. The entire concept was successfully tested for suitability for series production and safety even under extreme conditions.

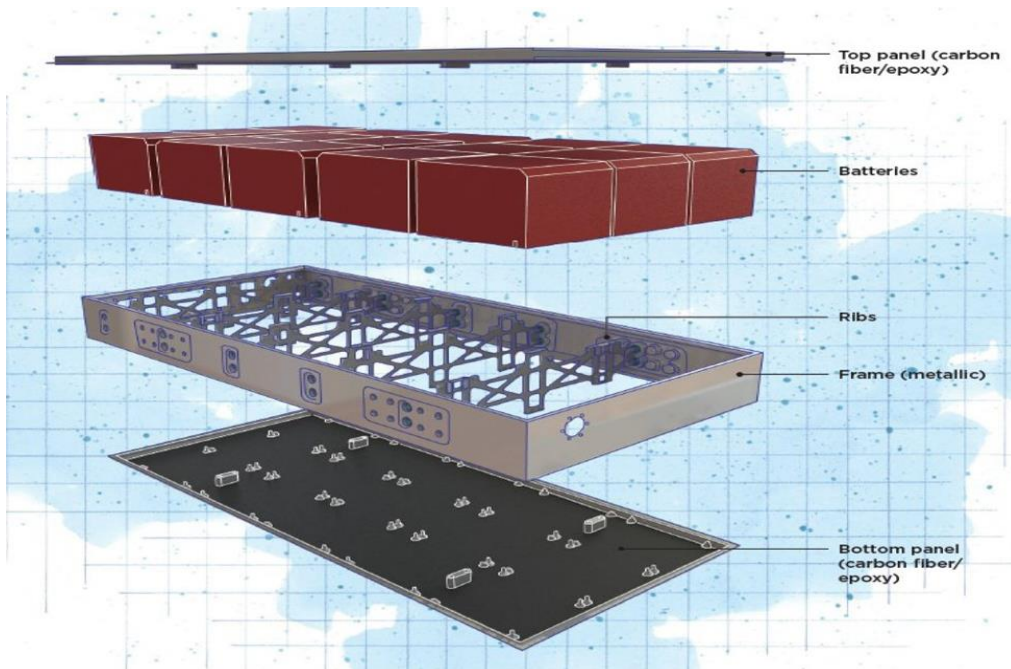


**Figure 29** : Multi-material battery enclosure from LION Smart [21]



### 3.2.2 Use of Carbon Fiber/Epoxy and Ribs From TRB Group

Before TRB became involved, the bus manufacturer had begun work internally on design for a battery enclosure, with plans for an aluminum top cover and bottom cover. This metal design though, proved too heavy. Each electric bus features up to six, 74-kilowatt batteries, each weighing 550 kilograms including the battery enclosure. To meet overall weight requirements, the weight goal for the battery enclosure was only 15 kilograms. The aluminum enclosure weighed 64 kilograms. It's quite a reduction in weight, which then really pushed us towards the composite materials as opposed to aluminum or other metals. Space was also a factor: the battery enclosure needed to be 2 meters by 1 meter in size, and the enclosure could not deflect more than 1 millimeter in any direction due to space restrictions in the bus chassis. We didn't have a lot of room to play with. The space requirements that they had within the battery [space] itself were very tight. In April 2018, TRB held a kaizen event - a five-day brainstorming event - to learn more about the enclosure requirements and to develop material and process solutions that meet these needs. The company needed a composite material that met the customer's fire, smoke and toxicity (FST) requirements, was able to cure quickly and also fell within the target price range. None of the prepreg options TRB evaluated from other suppliers met all of the requirements - at least not cost-effectively for the volume. In transitioning the design to composites, TRB was able to reduce the overall skin thickness of the panel while also adding shape in the form of molded-in internal ribs. The ribs added a lot more rigidity to the part, and meant we could reduce the skin thickness even more. Overall, base cover thickness was reduced from 14 to 4.5 millimeters; top cover thickness was reduced to just more than 2 millimeters. The base is thicker and stronger to bear the weight of the battery. The top cover is essentially a lid and there is a slightly different design and material selection because of it.



**Figure 30** : Battery box from TRB group [22]

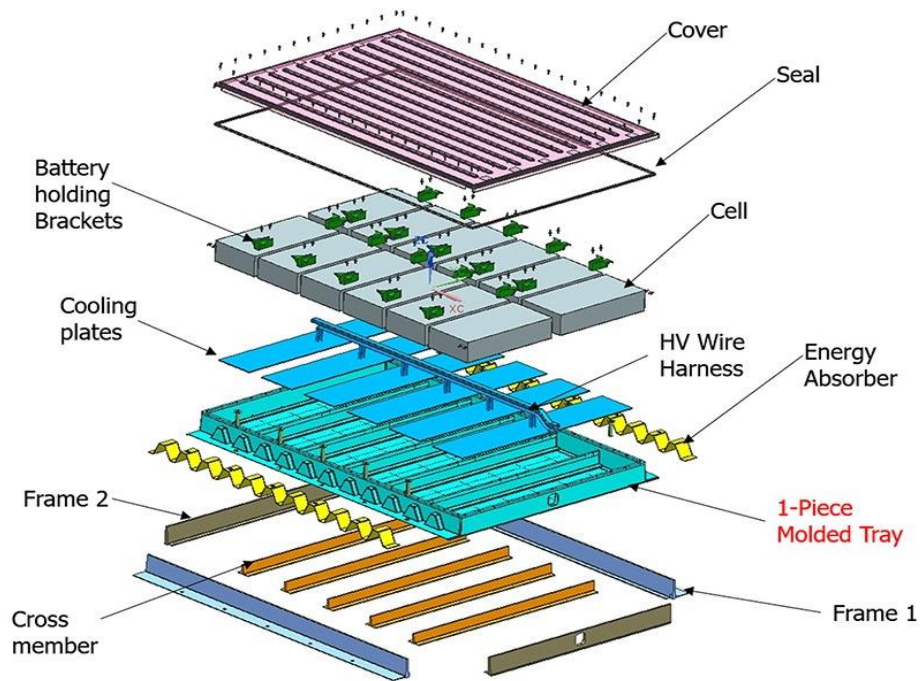
### 3.2.3 Multi-material EV Battery Enclosure From CSP

On Sept. 24, 2021 it was reported that Teijin Group company Continental Structural Plastics (CSP Auburn Hills, Mich., U.S.) is developing composite and multi-material battery covers and full battery enclosures for electric vehicles (EV). Features including light weight, structural integrity and reduction/elimination of fire and thermal runaway were key priorities when choosing the material.

According to CSP this was made easier as itself, Inapal Plásticos (Leça do Balio, Portugal) and Benet Automotive s.r.o. (Benet; Mlada Boleslav, Czech Republic), all under the Teijin umbrella, are said to have more than 200 years of combined carbon fiber and glass fiber composites technology expertise. This material and design experience, says CSP, has enabled the team to develop advanced battery enclosure technologies to help automakers overcome design and regulatory challenges.

Further, the glass-fiber composite materials are said to allow for greater design freedom and parts integration when compared to metallic options. Additionally, the seamless box structure is watertight and cost-competitive over an aluminum structure.

CSP says it has also developed SMC materials that offer a number of unique fire resistance capabilities, including the ability to reduce or eliminate thermal runaway, and the ability to self-extinguish. The company has been manufacturing EV battery enclosures since 2012, working in conjunction with General Motors (GM; Detroit, Mich., U.S.) on the Chevrolet Spark program. Today, CSP is in development and production of 34 battery box covers in both the U.S. and China.



**Figure 31** : An exploded view of CSP's multi-material battery enclosure [23]

### 3.2.4 VARI Technology for Carbon Fiber Battery Box

The battery box requires high strength, lightweight, and excellent corrosion resistance for materials. Carbon fiber has significant advantages in these three aspects. First, carbon fiber has higher specific strength (the ratio of the material's tensile strength to the density) and specific modulus (the ratio of the material's elastic modulus to the density), and its specific strength is five times that of steel. The carbon fiber and epoxy resin composite density is 1.4 kg/m<sup>3</sup>. The material also has excellent corrosion resistance and flame retardancy.

There are many molding methods for carbon fiber composite products. Among them, the processing technologies suitable for carbon fiber battery cases include molding, vacuum assisted molding, resin transfer molding, and so on. According to the requirements of the output and cost of the parts and the process capability of the existing domestic composite material manufacturers, the VARI process was finally selected for the production of the carbon fiber battery box.

VARI (vacuum-assisted resin infusion) is a process of vacuum-assisted introduction of dry fabric into forming. The process principle is to cover and seal the fiber reinforced material with a flexible vacuum bag film on a single-sided rigid mold, use vacuum negative pressure to remove the gas in the mold cavity, and drive the resin to flow through the vacuum negative pressure to realize the resin to the fiber and the fabric.



**Figure 32** : VARI technology for carbon fiber battery box [24]

### 3.2.5 Plastics Trim EV Batteries' Weight Boost Safety

In Germany, specialty chemicals company Lanxess and Kautex Textron, an automotive supplier, have collaborated for several years to research whether battery housings for EVs can be designed and manufactured from technical thermoplastics.

They announced in November 2022 that as part of a demonstration project, they developed an all-plastic battery housing with a weight in the range of 88 pounds to 132 pounds using glass-fiber-reinforced composites. The housing, measuring 4.6 feet in both length and width, weighs significantly less than comparable steel and aluminum housings, the companies said. It consists of a housing tray with crash structure, a housing cover and an underrun (underbody) protection.

The battery housing was developed as part of a demonstration project using a single-stage direct long-fiber thermoplastic (D-LFT) molding process. The process is unique to compression molding and is used for mid to large size battery housings for EVs and plug-in hybrid electric vehicles, according to Lanxess. Lanxess has optimized its Durethan B24CMH2.0 PA6 resin for the D-LFT molding compound. Kautex Textron compounds the PA6 for the process with glass-fiber roving. Local reinforcement of the housing structure is carried out using Tepex Dynalite continuous fiber-reinforced thermoplastic composites from Lanxess, the company said.

Plastics also are corrosion-resistant and electrically insulating, meaning there is a reduced risk of the system short circuiting or arcing, according to the companies. The lower weight of the plastic housing can help boost the range of EVs. Plastic housings, consisting of a tray and cover, must also be designed to absorb a significant amount of energy in the event of a crash, and be flame retardant in case of a vehicle fire or thermal runaway of the electrical cells.

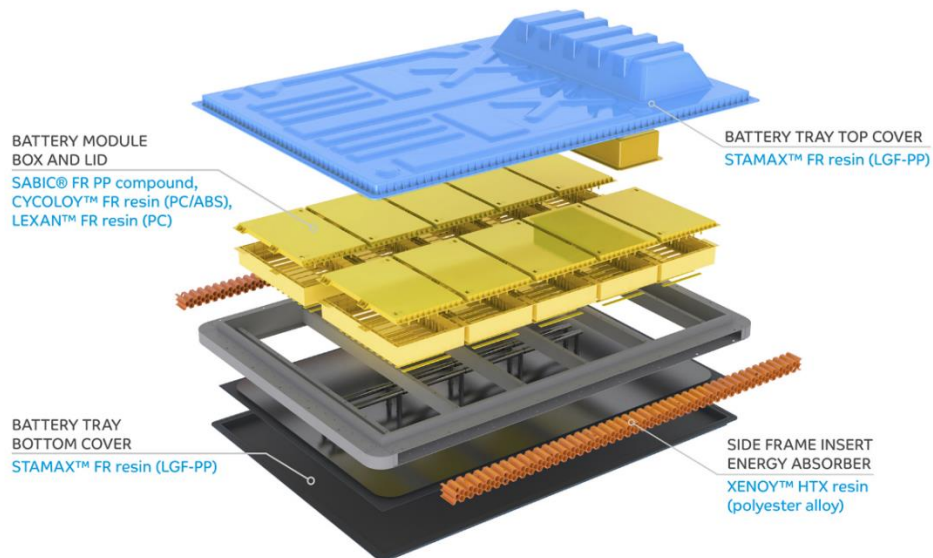


**Figure 33** : Kautex Textron and Lanxess all plastic battery housing [25]

### 3.2.6 Glass-Fiber PP EV Battery Pack From SABIC

Compared with conventional battery pack designs using traditional materials such as aluminum and other metals, lightweight thermoplastics potentially can realize 30 to 50% weight savings per component, improve energy density, simplify the assembly process, reduce costs, and improve thermal control and safety. The Sabic developed battery pack concept leverages the properties and strength of thermoplastics to improve performance, reduce cost and weight, and support mass production. Highlights include:

- Integration of individual batteries into pouch cells placed within a thin-walled housing molded with a 30% glass-fiber-filled, flame-retardant (FR) polypropylene (PP) compound.
- Geometric features, such as a double-wall construction, a novel rib pattern, and creative functional integration, all enabled by Sabic thermoplastics to reduce weight and meet structural requirements.
- Creative use of the anisotropic thermal conductivity of plastics to optimize thermal management performance.
- Integrated plastic-metal hybrid structures with Stamax FR long-glass-fiber PP material for the battery tray to optimize thermal transfer, meet drop test requirements, and absorb the significant impact energy that side frame members can experience.
- A battery pack enclosure or cover molded with Stamax FR resin. Use of this material meets the UL 94V-0 flammability rating and allows the cover to be metallized for electromagnetic interference (EMI) and radio frequency interference (RFI) shielding.
- Parts reduction and assembly efficiency, resulting in cost savings, enabled through the inherent design freedom of thermoplastics.



**Figure 34** : Battery box from SABIC concept [26]

### 3.3 Conclusion From Patent and Non-Patent Research

According to searching general concepts from patent research of battery boxes for the electric vehicle, some selected patents are listed in this chapter, and some are not mentioned. We noticed that the design of battery boxes for electric vehicles is currently developing very often in the following directions:

- Using composite components
- Using organic material
- Using sealants and bonding technology
- Explosion resistance
- Increased impact and collision resistance
- Integration of the cooling subsystem
- Theft-resistant (costly) batteries

The analysis of the innovation potential showed that the most significant innovation potential (in terms of coverage of intellectual property rights) in the case of electric vehicle battery boxes has technical solutions based on the development of these "standard" features of the innovated products:

- Using fibers
- Transparency
- Fragmentation
- Automation
- Pulsation
- Symmetry

Analysis of the non-patent research showed that many different battery boxes on the market have very different concepts of components and materials. The research shows that a multi-material approach, which uses the right (often non-metallic) material in the right place for each specific requirement, is increasingly being used. Different materials also support the modular solution of covers and entire battery subsystems. As battery boxes and enclosures for electric vehicles are seen as one of the most significant areas of potential growth and a safety concern, developing test facilities is also a critical innovation opportunity. The next chapter will generate our concepts by synthesizing lecturer review, patent, and non-patent research information. There will be five conceptual designs, and we will explain each concept with its description of construction design, material selection, and battery thermal management and illustrate them by sketching.

## 4 Design Concepts

The design concept is the core idea driving the design. Generally, the term concept is a compilation of sketches, photographs, illustrations, images, 2D or 3D models, and a written statement explaining a design's primary idea. The first step to creating a design concept is identifying the problem one aims to solve. Thanks to the information from the previous chapters, I can make five concepts, introduce them in the following subsections, and illustrate them by sketching.

### 4.1 Concept 1

#### Description

Concept 1 involves the creation of a battery box comprising a box body and cover. The box body incorporates ribs to encase and shield the battery module securely, and we utilize screws for the assembly's connection between the box body and cover. Additionally, prismatic cells are selected for stacking within the battery module.

#### Material Selection

Aluminum alloy

#### Battery Thermal Management

We use a cooling system called liquid cooling. Because we design a box body with ribs to house the battery modules, we position the cooling plate under the battery box to transfer heat by coolant flow and use lower protection to protect the cooling plate.

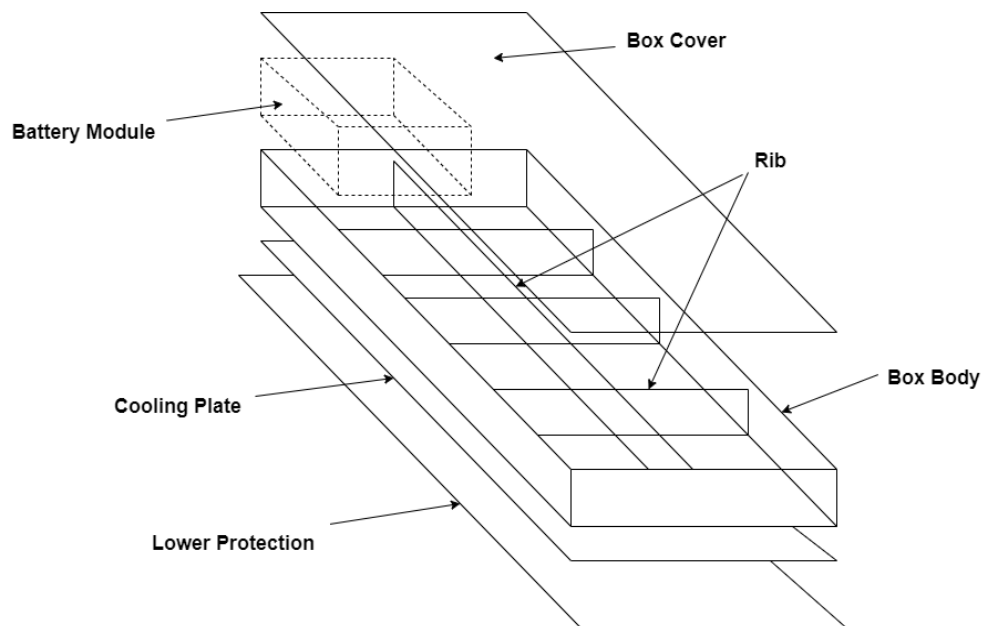


Figure 35 : Concept 1

## 4.2 Concept 2

### Description

In concept 2, we design the battery box similar to concept 1. But in this concept, we use the crash structure to house and protect the battery modules and use screws to connect the box body and cover. Similar to the previous concept, we selected prismatic cells for stacking within the assembly and placement inside the battery module.

### Material Selection

Carbon Fiber

### Battery Thermal Management

In this concept, we still use a cooling system called liquid cooling. Because we use a crash structure to house and protect the battery modules, we can directly insert the cooling plate inside the battery box. First, we place the cooling plate on the box body, then set the crash structure on the cooling plate, and finally, we put the battery modules.

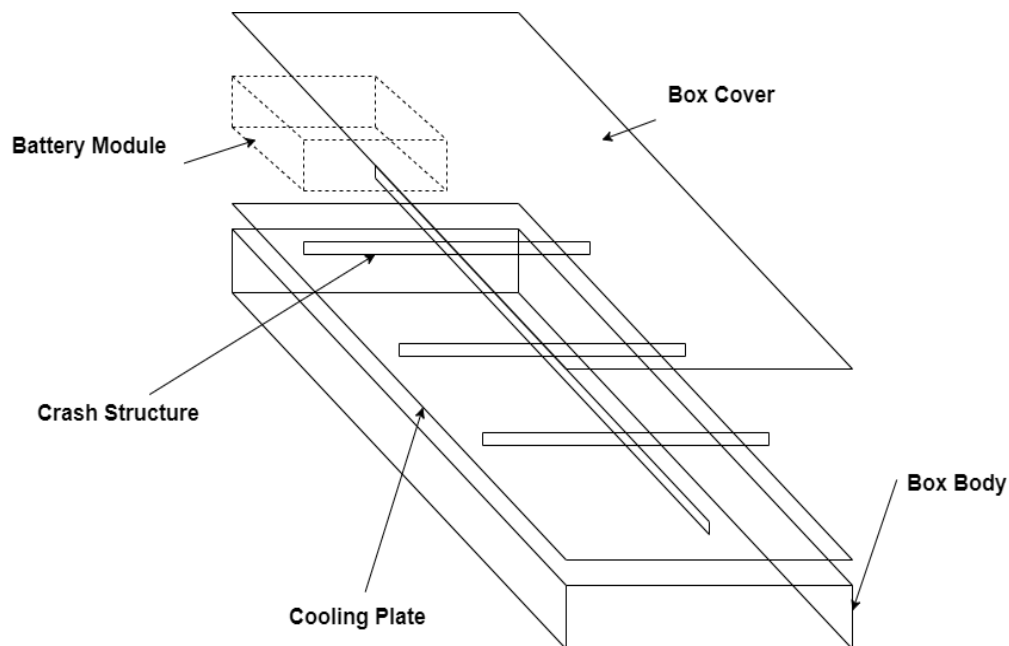


Figure 36 : Concept 2

## 4.3 Concept 3

### Description

In concept 3, we design the battery box similar to concepts 1 and 2. However in this concept, we use the housing tray to house and protect the battery modules and use screws to connect between



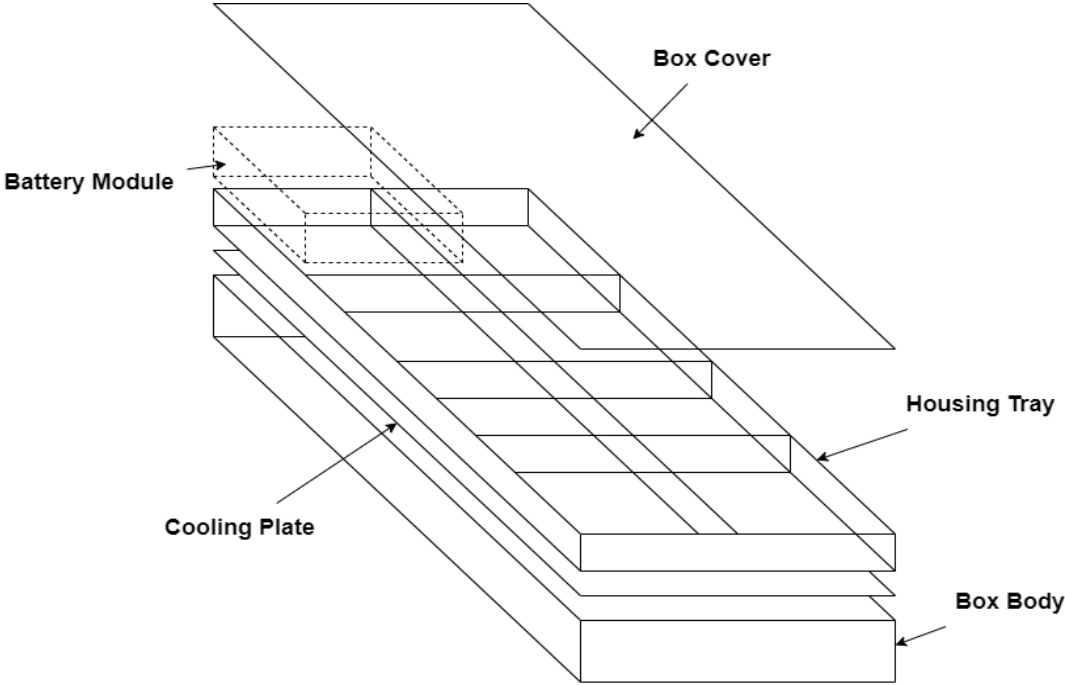
the battery box and cover. Also, we decided to use prismatic cells to stack the assembly and put them in the battery module.

**Material Selection**

Glass Fiber

**Battery Thermal Management**

In this concept, we still use a cooling system called liquid cooling. Because we use a housing tray to house and protect the battery modules, we can use the cooling plate insert on the box body and then put the housing tray on the cooling plate. Finally, we place the battery modules inside the housing tray.



**Figure 37 : Concept 3**

**4.4 Concept 4**

**Description**

In concept 4, We still design the battery box using a rectangular shape like concepts 1, 2, and 3. We create a box body with ribs to house and protect the battery modules and use screws to connect between the box cover and body. In this concept, we use the cylindrical battery, which differs from concepts 1, 2, and 3 because we use different method for battery thermal management.

**Material Selection**

Stainless steel

### Battery Thermal Management

In this particular concept, we employ phase change composite material to remove the heat from the cylindrical cells. First, we create a phase change composite material with holes to accommodate the cylindrical cells, which are subsequently integrated into the battery module.

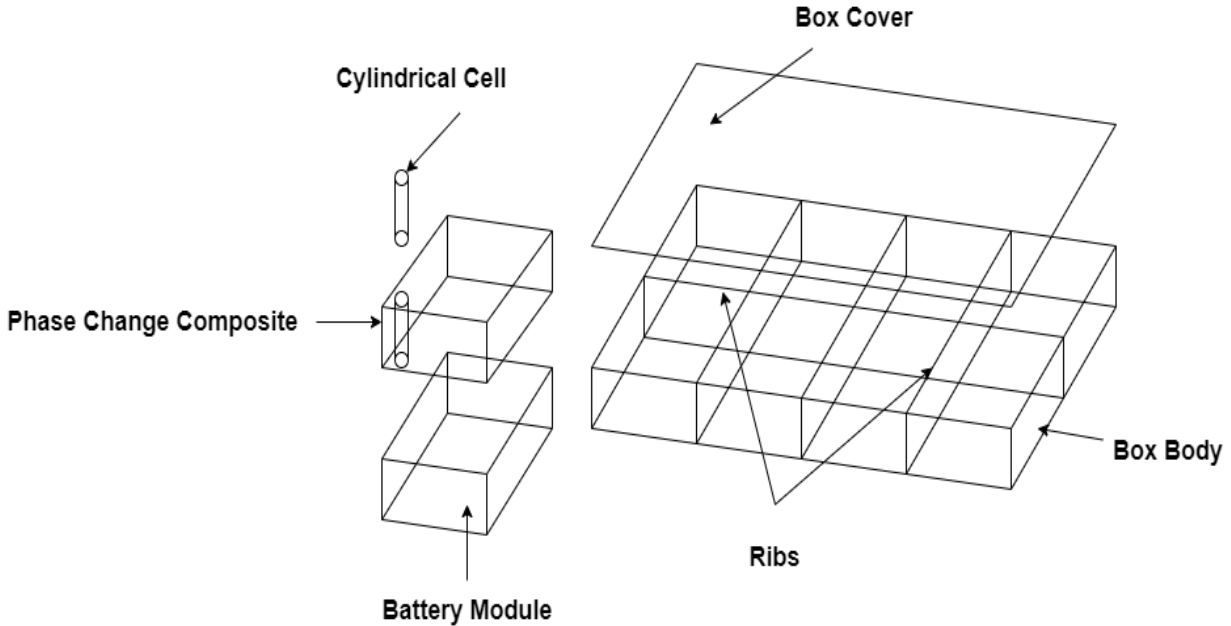


Figure 38 : Concept 4

## 4.5 Concept 5

### Description

In concept 5, we design the battery box with a rectangular shape like the previous concept. But in this concept, we do not use the battery modules; we directly assemble the prismatic cells into the box body. We use a crash structure to house and protect the battery cells inside the box and use screws to connect between the box body and cover.

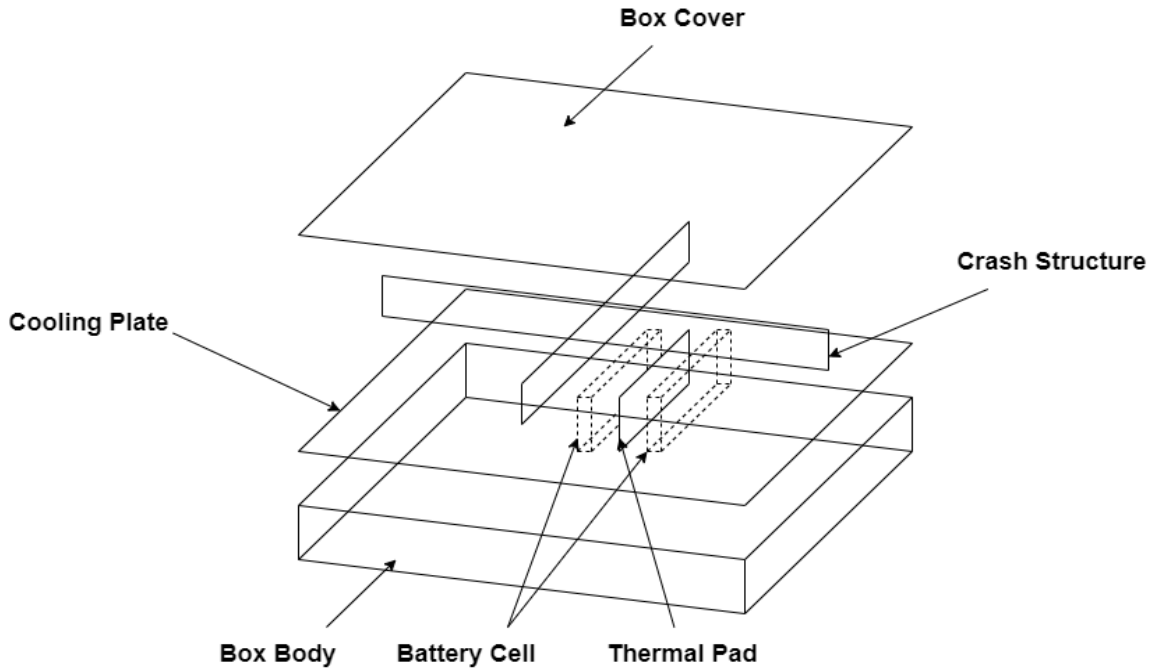
### Material Selection

Multi materials

### Battery Thermal Management

In this concept, we still use a cooling system called liquid cooling. First, we put the cooling plate inside the box body and put the crash structure on the cooling plate to house and protect the battery

cells. Then, we use the thermal pad to set between battery cells to prevent heat between cells inside the box.



**Figure 39 : Concept 5**

## **5 Selection Final Concept**

The final concept selection is a process that deals with evaluating and comparing the proposed concepts. Based on the proposed concepts in the previous chapter, it is necessary to select one (in some cases, it is possible to choose several concepts) for further development, improvement, and testing. We will select the final concept using the AHP (Analytic Hierarchy Process) method. The Analytic Hierarchy Process (AHP) method, also known as the Saaty method, was introduced in 1980 by Professor Thomas Saaty and is an effective tool for solving complex decisions between several options. It can help the user to prioritize and make the best decisions. First, it is necessary to determine a set of evaluation criteria and options (concepts) by which the best decision will be made. AHP generates a weight for each criterion according to the pairwise comparison of the criteria recorded in the table. Next, in the same way, the concepts are compared according to each criterion. Finally, AHP combines the weight of criteria and option scores to determine a global score for each option and subsequent ranking.

### **5.1 Selecting Criteria**

The chosen criteria for evaluating the concept are as follows:

- **A - Lightweight** : The weight of an electric vehicle affects its overall performance. In fact, EV manufacturers keep finding appropriate means to cut down weight without losing efficiency, and one such is to reduce the weight of the battery housing. In addition, weight reduction too may play a critical role in improving the acceptance of these automobiles by the general public.
- **B - Electrical insulation** : Batteries are energy storage houses for automobiles. They store chemical energy which transforms into electrical energy to power the electric vehicle. If not correctly installed and covering the battery is 100 percent, it may lead to leakage, which can cause accidents. Therefore, there is a need for a proper insulating system to secure the passengers in the vehicle.
- **C - Safety** : Safety is one of the most critical factors in EV battery design since battery failure may lead to catastrophic consequences. Besides serving as battery housing, the EV battery box should offer protection to drivers and passengers, especially in the case of a car crash, fire protection, low thermal conductivity, electromagnetic compatibility, vibration, etc.
- **D - Cost** : The main costs of which are battery cells and assembling processes. Battery manufacturers price the battery cell, while the assembling cost depends on battery pack designs. Material selection and assembly methods, such as component design, are significant for determining cost-effectiveness for battery modules and battery packs.
- **E - Modular designs** : The battery box design should contain individualized circuits and compartments that include the power electronics and the battery cooling system. The automotive battery box design should permit easy replacement of battery cells.

### 5.1.1 Comparison of Criteria

As mentioned above, we will compare the selected criteria using the AHP method. We will create the pairwise and normalization comparison matrix of criteria.

**Table 4** : Pairwise comparison matrix of criteria

	A	B	C	D	E
A	1	7	2	2	5
B	0.14	1	0.2	0.2	0.14
C	0.5	5	1	3	4
D	0.5	5	0.33	1	2
E	0.2	7	0.25	0.5	1
Total	2.34	25.00	3.78	6.70	12.14

**Table 5** : Normalization pairwise comparison matrix of criteria

	A	B	C	D	E	Weight
A	0.43	0.28	0.53	0.30	0.41	0.389
B	0.06	0.04	0.05	0.03	0.01	0.039
C	0.21	0.20	0.26	0.45	0.33	0.291
D	0.21	0.20	0.09	0.15	0.16	0.163
E	0.09	0.28	0.07	0.07	0.08	0.118
Total	1	1	1	1	1	1

## 5.2 Comparison of Concepts According to Criterion

In this subsection, we will compare all concepts according to each criterion. In the previous chapter, we finished generating five concepts. Here is the list of concepts:

- C1 - The battery box is made from aluminum alloy
- C2 - The battery box is made from carbon fiber
- C3 - The battery box is made from glass fiber
- C4 - The battery box is made from stainless steel
- C5 - The battery box is made from multi materials

### • Comparison of concepts according to lightweight

**Table 6** : Pairwise comparison matrix of concepts according to lightweight

A	C1	C2	C3	C4	C5
C1	1	0.11	0.14	2	0.33
C2	9	1	2	5	3
C3	7	0.5	1	5	3
C4	0.5	0.2	0.2	1	0.5
C5	3	0.33	0.33	2	1
Total	20.50	2.14	3.68	15.00	7.83

**Table 7** : Normalization pairwise comparison matrix of concepts according to lightweight

A	C1	C2	C3	C4	C5	Weight
C1	0.05	0.05	0.04	0.13	0.04	0.063
C2	0.44	0.47	0.54	0.33	0.38	0.433
C3	0.34	0.23	0.27	0.33	0.38	0.313
C4	0.02	0.09	0.05	0.07	0.06	0.061
C5	0.15	0.16	0.09	0.13	0.13	0.131
Total	1	1	1	1	1	1

• **Comparison of concepts according to electrical insulation**

**Table 8** : Pairwise comparison matrix of concepts according to electrical insulation

B	C1	C2	C3	C4	C5
C1	1	0.11	0.14	1	0.33
C2	9	1	1	5	3
C3	7	1	1	5	3
C4	1	0.2	0.2	1	0.33
C5	3	0.33	0.33	3	1
Total	21.00	2.64	2.68	15.00	7.67

**Table 9** : Normalization pairwise comparison matrix of concepts according to electrical insulation

B	C1	C2	C3	C4	C5	Weight
C1	0.05	0.04	0.05	0.07	0.04	0.051
C2	0.43	0.38	0.37	0.33	0.39	0.381
C3	0.33	0.38	0.37	0.33	0.39	0.362
C4	0.05	0.08	0.07	0.07	0.04	0.062
C5	0.14	0.13	0.12	0.20	0.13	0.145
Total	1	1	1	1	1	1

• **Comparison of concepts according to safety**

**Table 10** : Pairwise comparison matrix of concepts according to safety

C	C1	C2	C3	C4	C5
C1	1	0.5	0.5	1	3
C2	2	1	1	3	3
C3	2	1	1	3	2
C4	1	0.33	0.33	1	2
C5	0.33	0.33	0.5	0.5	1
Total	6.33	3.17	3.33	8.50	11.00

**Table 11** : Normalization pairwise comparison matrix of concepts according to safety

C	C1	C2	C3	C4	C5	Weight
C1	0.16	0.16	0.15	0.12	0.27	0.171
C2	0.32	0.32	0.30	0.35	0.27	0.311
C3	0.32	0.32	0.30	0.35	0.18	0.293
C4	0.16	0.11	0.10	0.12	0.18	0.133
C5	0.05	0.11	0.15	0.06	0.09	0.092
Total	1	1	1	1	1	1

• **Comparison of concepts according to cost**

**Table 12** : Pairwise comparison matrix of concepts according to cost

D	C1	C2	C3	C4	C5
C1	1	3	3	2	2
C2	0.33	1	0.5	0.33	0.5
C3	0.33	2	1	0.33	0.5
C4	0.5	3	3	1	2
C5	0.5	2	2	0.5	1
Total	2.67	11	9.50	4.17	6

**Table 13 :** Normalization pairwise comparison matrix of concepts according to cost

D	C1	C2	C3	C4	C5	Weight
C1	0.38	0.27	0.32	0.48	0.33	0.355
C2	0.13	0.09	0.05	0.08	0.08	0.086
C3	0.13	0.18	0.11	0.08	0.08	0.115
C4	0.19	0.27	0.32	0.24	0.33	0.270
C5	0.19	0.18	0.21	0.12	0.17	0.173
Total	1	1	1	1	1	1

• **Comparison of concepts according to modular design**

**Table 14 :** Pairwise comparison matrix of concepts according to modular design

E	C1	C2	C3	C4	C5
C1	1	2	2	0.2	3
C2	0.5	1	2	0.2	3
C3	0.5	0.5	1	0.2	3
C4	5	5	5	1	3
C5	0.33	0.33	0.33	0.33	1
Total	7.33	8.83	10.33	1.93	13

**Table 15 :** Normalization pairwise comparison matrix of concepts according to modular design

E	C1	C2	C3	C4	C5	Weight
C1	0.14	0.23	0.19	0.10	0.23	0.178
C2	0.07	0.11	0.19	0.10	0.23	0.142
C3	0.07	0.06	0.10	0.10	0.23	0.111
C4	0.68	0.57	0.48	0.52	0.23	0.496
C5	0.05	0.04	0.03	0.17	0.08	0.073
Total	1	1	1	1	1	1



• **Table of relative priority**

**Table 16** : Table of relative priority

Concept	Weight according to criteria					Criteria	Weight
	A	B	C	D	E		
C1	0.063	0.051	0.171	0.355	0.178	A	0.389
C2	0.433	0.381	0.311	0.086	0.142	B	0.039
C3	0.313	0.362	0.293	0.115	0.111	C	0.291
C4	0.061	0.062	0.133	0.270	0.496	D	0.163
C5	0.131	0.145	0.092	0.173	0.073	E	0.118

• **Result of AHP**

**Table 17** : Result of AHP

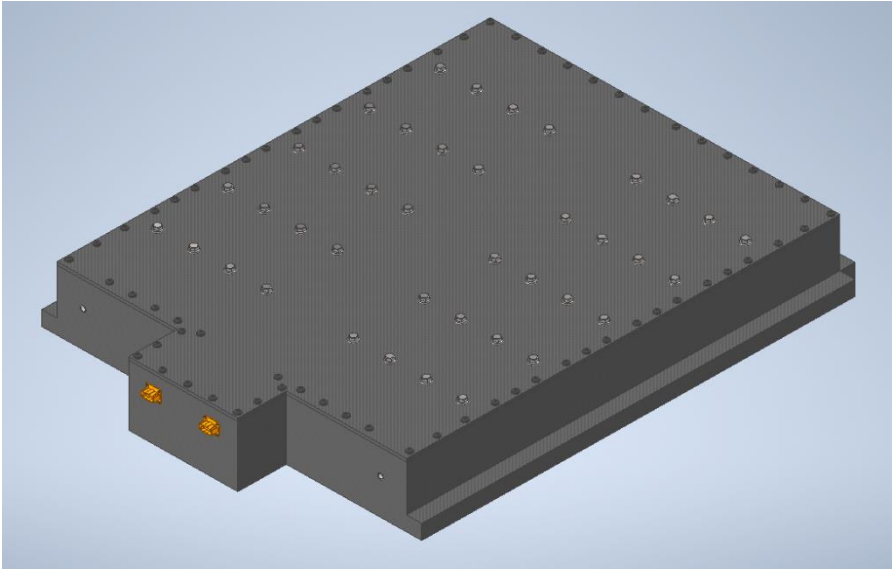
Concept	Weight	Priority
C1	0.155	3
C2	0.189	1
C3	0.185	2
C4	0.017	4
C5	0.015	5

AHP analysis showed the result priorities for individual concepts. From the AHP method, Concept 2, with a value of 0.189, emerged as the most suitable option, which was selected for further processing. In the table, Concept 3 also has a good score close to Concept 2 because we give significant criteria on lightweight, so Concept 3 can also be considered innovative. However, we select only one concept for the final step.

## 6 Construction Design

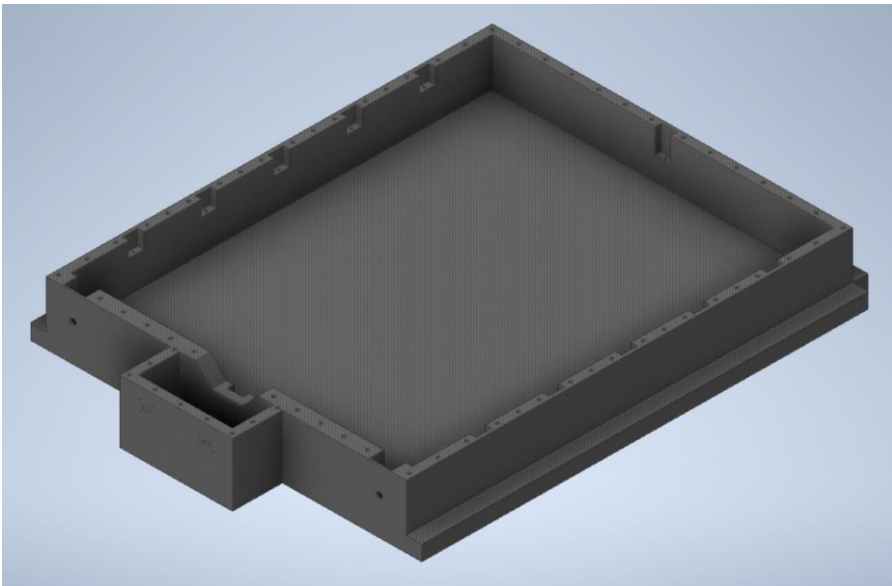
After the AHP analysis, the initial design of the entire technical system and initial modeling are carried out in this chapter. This battery box construction is based on Concept 2 from the previous chapter with a high AHP method because there are several criteria for constructing a winning concept. This box contains 12 battery modules, a crash structure, a cooling plate, a high-voltage box, high-voltage connectors, bus bars, a box body, a box cover, and standard bolts. We assemble all these main components to create a functional battery box for performance. The structural design

of the part is processed in Autodesk Inventor Professional 2022 software. In the following, we will describe the main components inside the battery box.

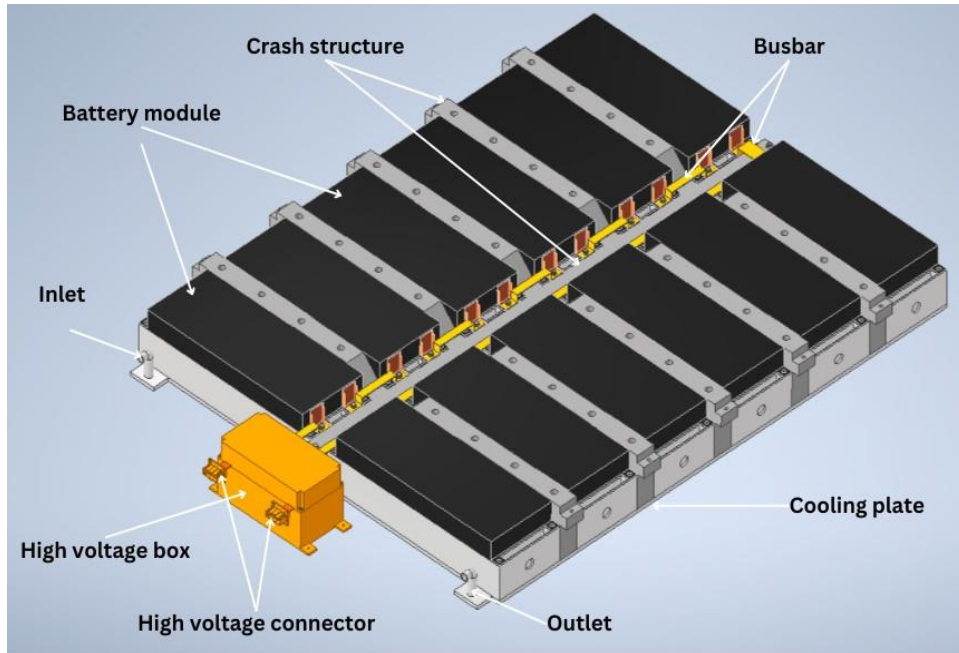


**Figure 40** : Battery box from composite material

This battery box for electric vehicles is made from composite material, especially the box body and cover. Composite material is perfect for innovation thanks to its properties because it provides superior performance compared to traditional materials. They offer a unique combination of properties, such as high strength, lightweight, electrical insulation, and resistance to wear and corrosion. So, selecting a battery box from composite material is a great idea to solve current problems with traditional materials like steel and aluminum.

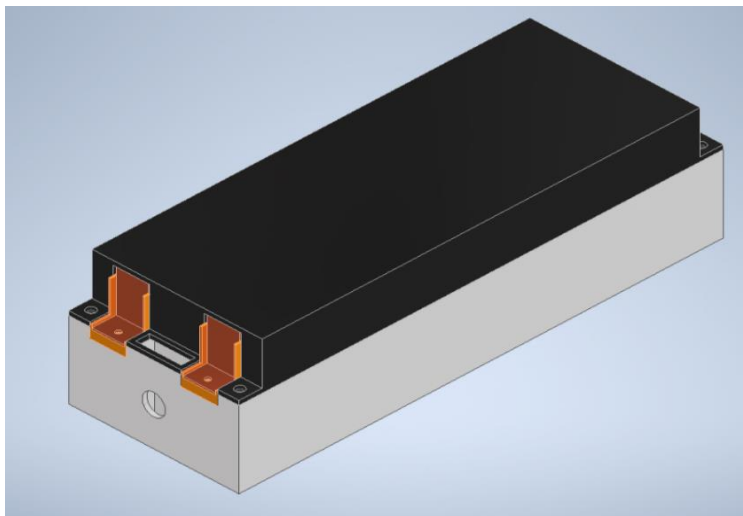


**Figure 41** : Battery box body from composite material



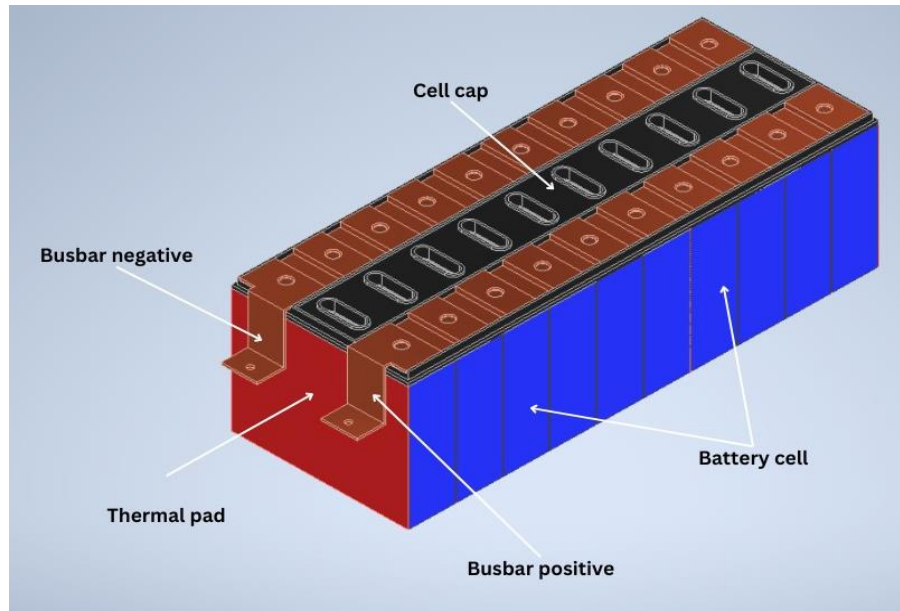
**Figure 42** : Components inside the battery box

In battery box construction, we first place the battery box body in a fixed position, then put the cooling plate on the box body. After that, we set the crash structure on the cooling plate and joined it with the box body by ISO 4162 M8 x 80. Then, we started putting the 12 battery modules on the cooling plate and connected the positive pole from one battery module to the negative pole at another battery module by busbar and fixed them with DIN 6921 M6 x 20. In front of the box body, we set the high-voltage junction box to control the charging system and battery pack connections. Finally, we can cover the box body with a box cover of ISO 7045 M10 and a box cover with a crash structure of ISO 4162 M16.



**Figure 43** : Battery module

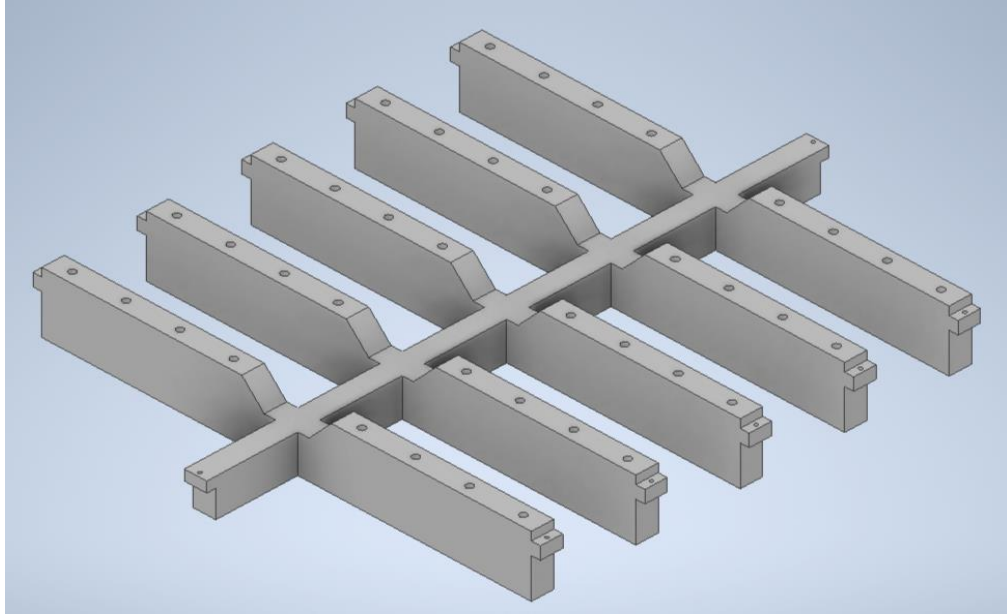
In our construction, 10 cells are combined into one module, and 12 modules are put together to go into the battery box in the form of a pack. The battery module body is made from aluminum because it is an excellent conventional material with good strength to protect the battery cells inside the module. Another thing is we want to transfer the heat from cells to the outside of the module through metal. The battery module cover is made from plastic because it is lightweight and prevents electrical conductivity from inside the module to outside.



**Figure 44** : Components inside the battery module

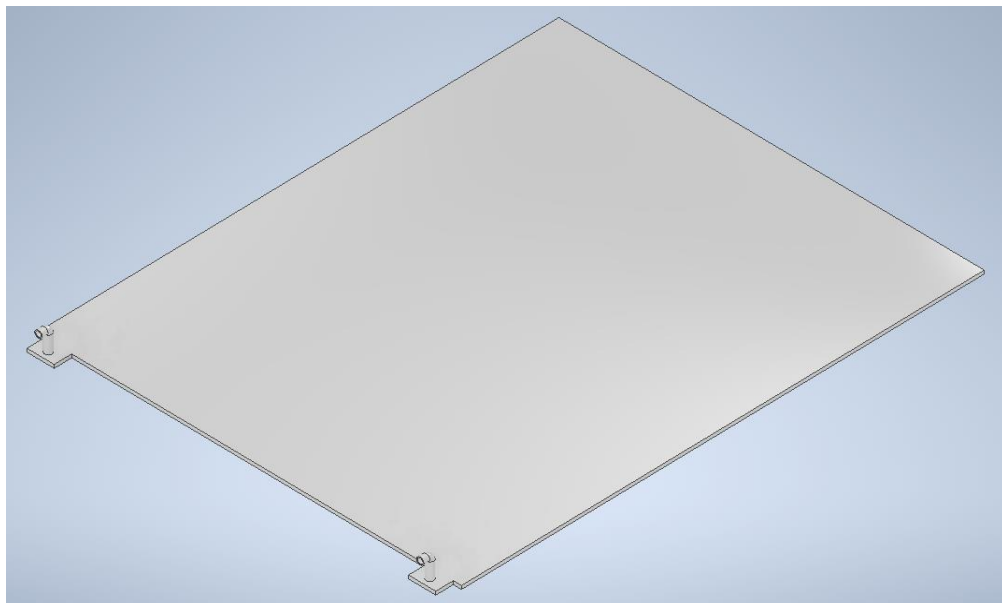
In battery module construction, I selected a Samsung SDI 94 Ah battery cell, and we will use this prismatic cells in our module. This battery cell has dimensions 173 mm x 125 mm x 45 mm, and this battery operates with a minimum nominal capacity of 94 Ah, a minimum voltage of 3.68 V, and an average energy of 345 Wh. We put the thermal pad grade silicon inside the module, which has excellent heat conductivity, non-flammability, and durability against high conductivity of 1 (W/m.K) between the cells and the battery module body to prevent the heat generated by the battery cells. After we assemble the cells and thermal pad, we use a cell cap to cover the upper part of the battery cells. In the next step, we weld the positive and negative busbar with the positive and negative cell terminal by friction welding. Finally, we connect the battery module body with the cover by ISO 7045 M4.

An efficient battery housing has many attributes that aid passenger and battery safety while protecting the battery from the harsh environment under the vehicle and in an accident. The system must be produced within the financial and weight constraints of the vehicle. The crash structure is one of the battery box's primary structures. We placed the crash structure inside the battery box for electric vehicle construction to divide and place the 12 battery modules to ensure they are not deformed and protect them from side impact. We decided to manufacture the crash structure in our design from the composite material thanks to its lightweight, mechanical strength, and electrical insulation.



**Figure 45 :** Crash structure

Electric vehicles replace combustion engines with electric motors, and large battery packs confront many new challenges. One such challenge is producing electric vehicle battery coolers, a critical component in electric vehicle thermal management systems. EV cooling plate regulates the battery pack's temperature by circulating coolant through an aluminum plate.

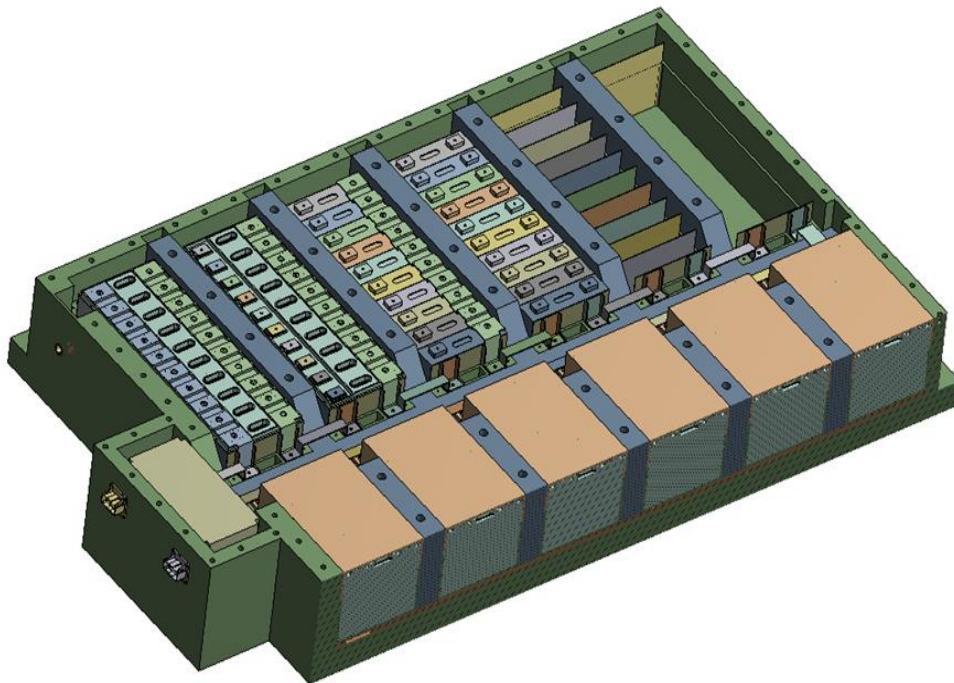


**Figure 46 :** Cooling plate

We designed a cooling plate comprising a top plate and a base plate. Inside the base plate, we create a groove with a 50 mm x 5 mm cross-section and 10 channels that become a coolant passage. We joined the top and base plate by friction stir welding to prevent fluid leaks.

## 7 Analysis of Temperature Inside The Battery Box By FEM

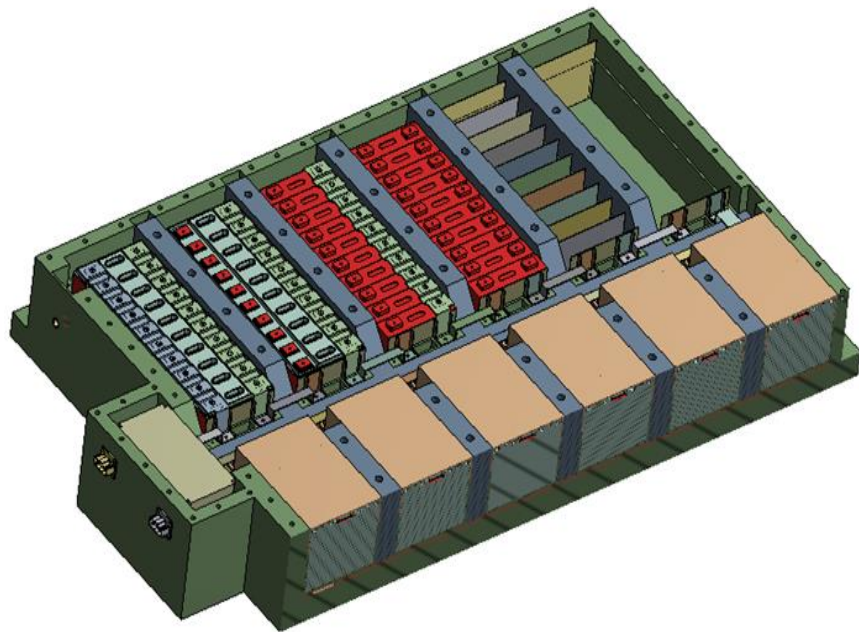
In this chapter, we critically explore temperature analysis within the battery box, driven by the heat generated from the battery cells within modules, using Finite Element Method (FEM) simulations facilitated by ANSYS software. By examining ANSYS, a powerful engineering simulation tool, we unravel its capabilities in predicting temperature variations within the battery enclosure. We can visualize the temperature distribution inside the battery box by inputting material properties and creating the thermal boundary conditions. After importing the model in the STEP file into ANSYS, the next step involves assigning materials to each part. This entails associating each component with the predefined material and specifying the relevant properties that were defined earlier in the process.



**Figure 47** : Model with distinct materials assigned to different parts in ANSYS

The next step is setting the boundary condition. Setting boundary conditions in steady-state thermal analysis is essential for obtaining physically meaningful and mathematically solvable solutions. The first boundary condition is that we set the battery cell at 50 degrees Celsius ( $^{\circ}\text{C}$ ), the highest temperature of the Samsung battery SDI 94 Ah.

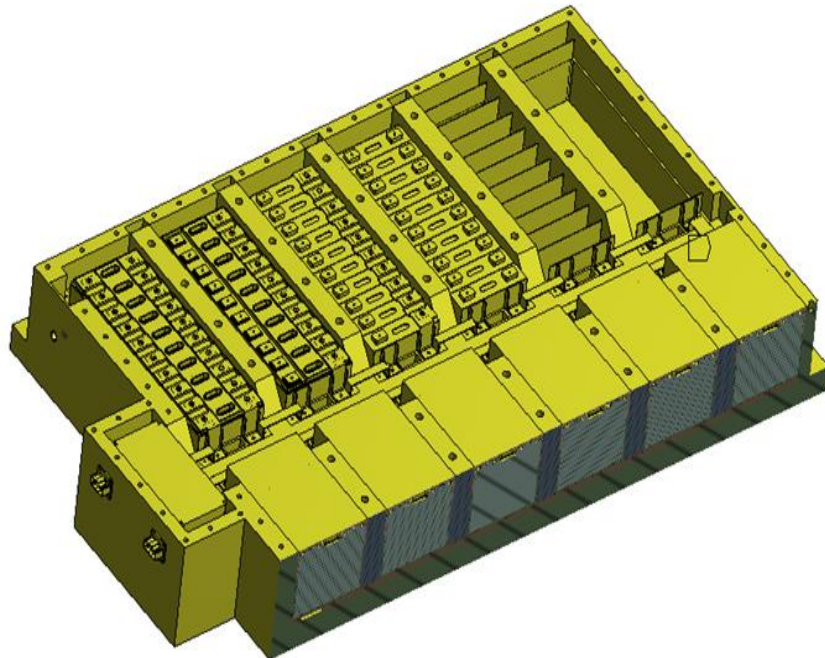
B: Steady-State Thermal  
Temperature - BATTERY  
Time: 1, s  
Temperature - BATTERY: 50, °C



**Figure 48** : The boundary condition for Samsung battery SDI 94 Ah

The second boundary condition is convection. We set the temperature to 22 degrees Celsius (°C) for the environment convection.

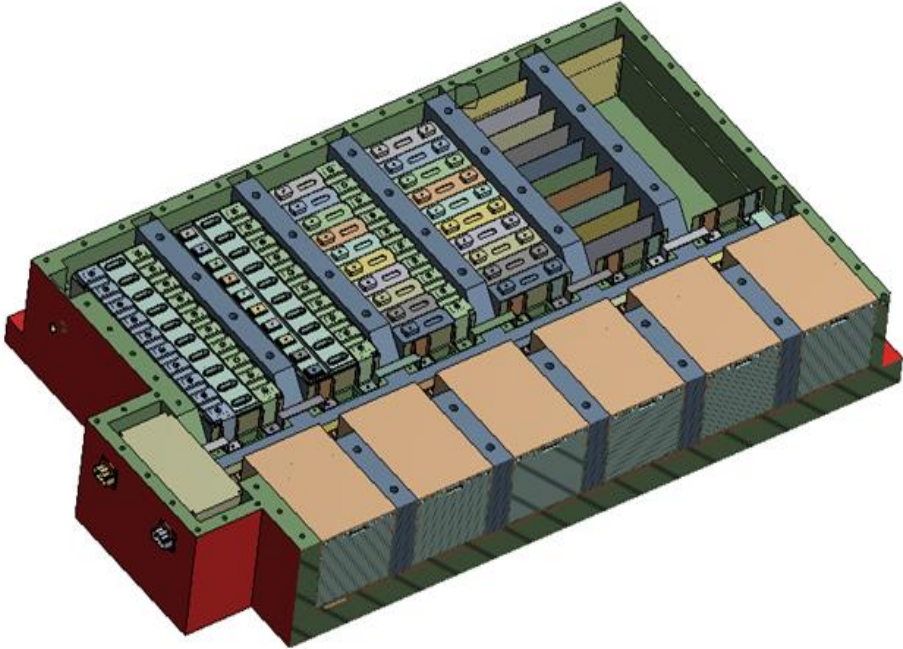
B: Steady-State Thermal  
Convection  
Time: 1, s  
Convection: 22, °C, 5,e-006 W/mm<sup>2</sup>·°C



**Figure 49** : The boundary condition for environment convection

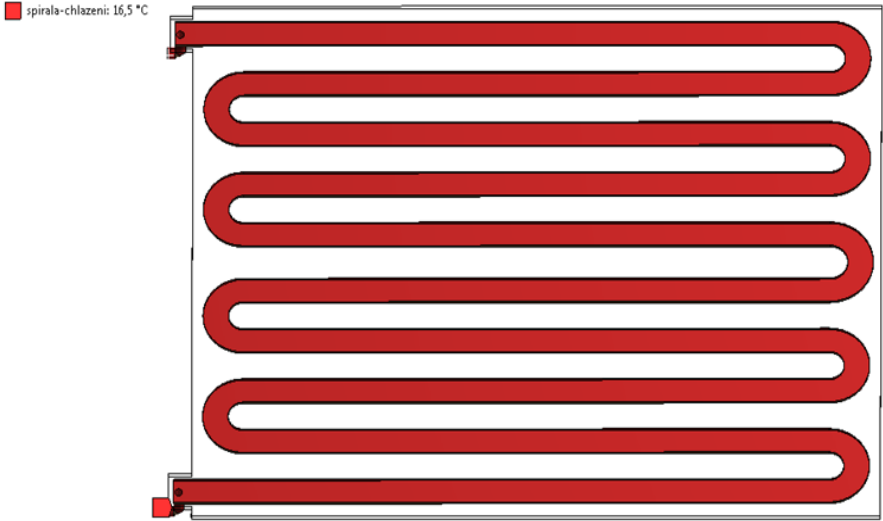
The third boundary condition is the temperature outside the box. We set the temperature to 20 degrees Celsius ( $^{\circ}\text{C}$ ) around the battery box.

B: Steady-State Thermal  
okoli  
Time: 1, s  
■ okoli: 20,  $^{\circ}\text{C}$



**Figure 50** : The boundary condition for the temperature outside the battery box

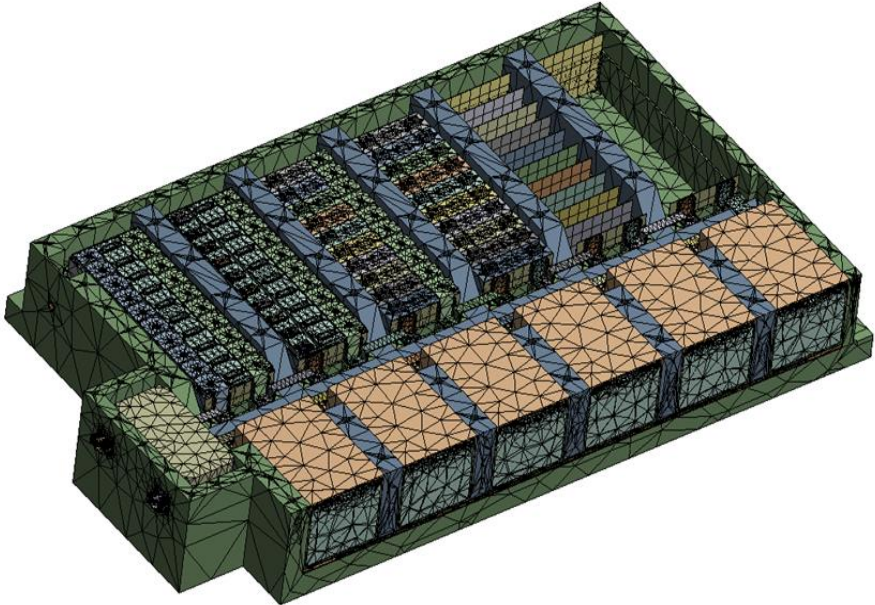
The fourth boundary condition is the temperature of the coolant going inside the cooling plate through the nozzle and flow inside the plate by groove, which is 16.5 degrees Celsius ( $^{\circ}\text{C}$ ).



**Figure 51** : The boundary condition for the coolant temperature

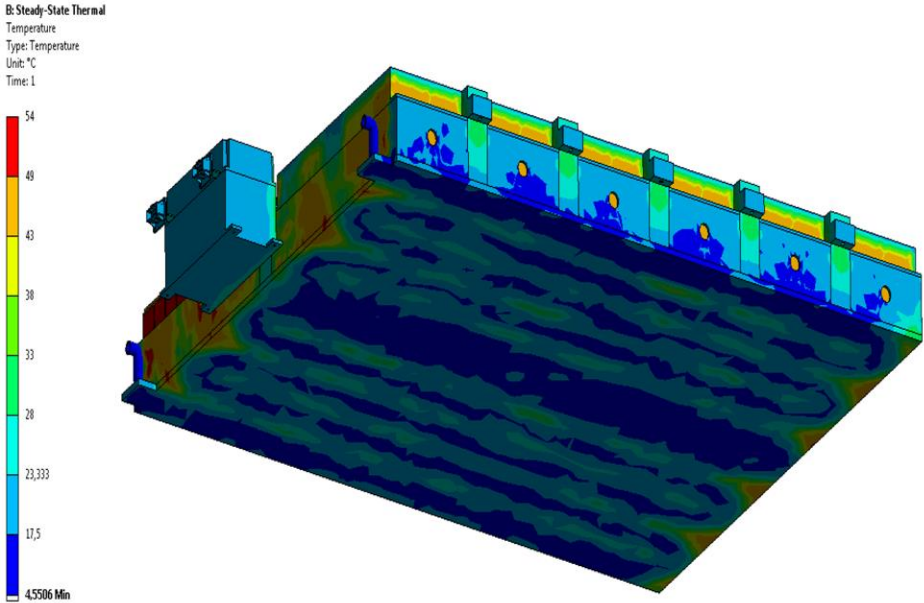


After that, we generate the mesh in ANSYS simulations, essential for converting complex geometries into a form suitable for numerical analysis. It enables the application of boundary conditions, improves solution accuracy, and facilitates the efficient computation of results for analysis.

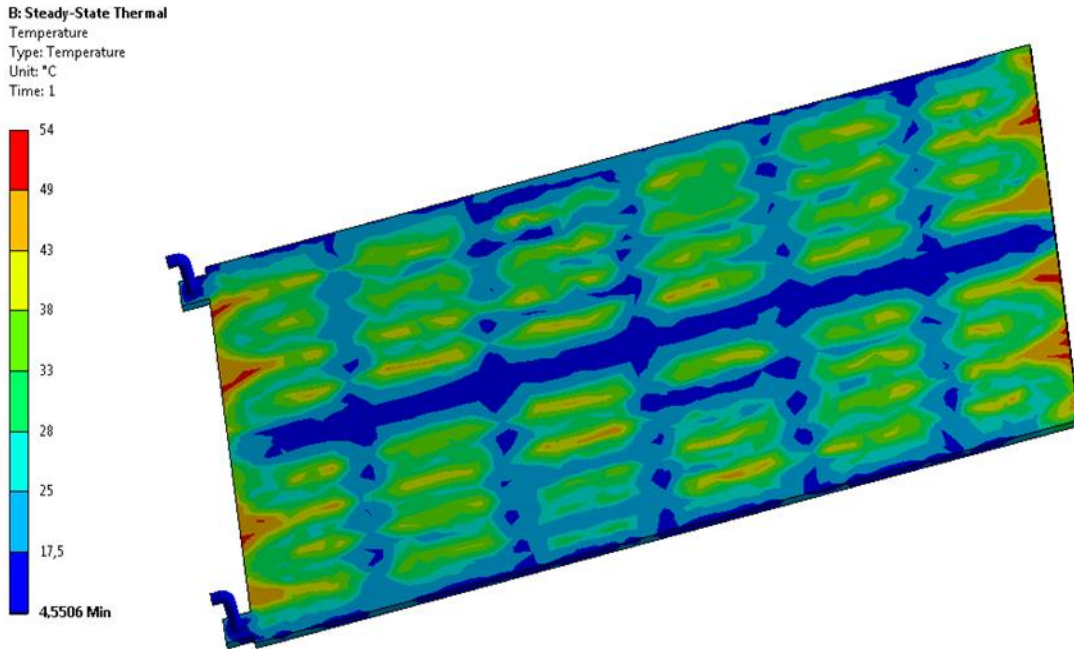


**Figure 52 :** Mesh generation

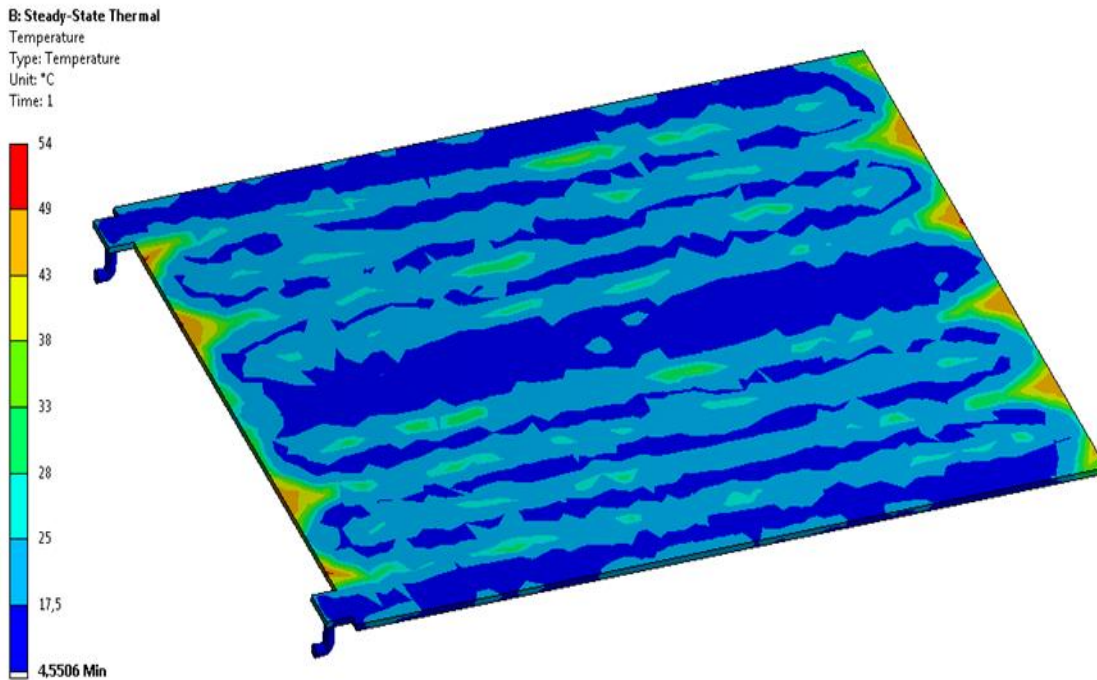
After assigning the material, creating the boundary conditions, and generating the mesh, we got the results from the simulation.



**Figure 53 :** The temperature field outside the battery modules with the cooling system



**Figure 54** : The temperature field of the upper surface cooling plate contact with battery modules



**Figure 55** : The temperature field of the lower surface cooling plate contact with battery modules

B: Steady-State Thermal  
Temperature  
Type: Temperature  
Unit: °C  
Time: 1

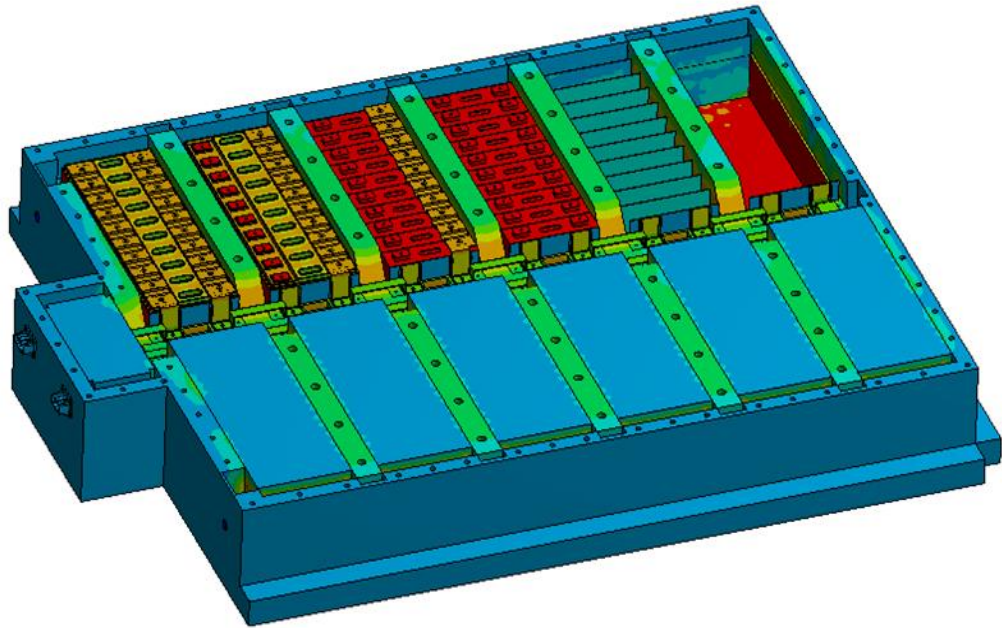
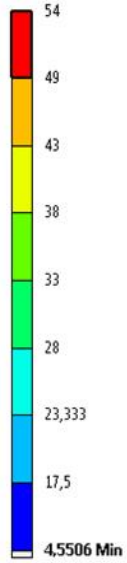


Figure 56 : The temperature field inside the battery box

B: Steady-State Thermal  
Temperature  
Type: Temperature  
Unit: °C  
Time: 1

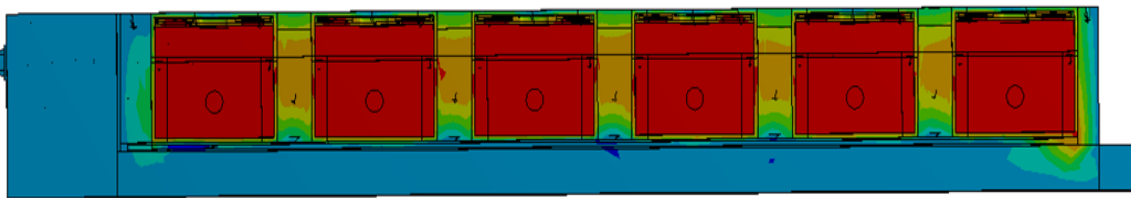
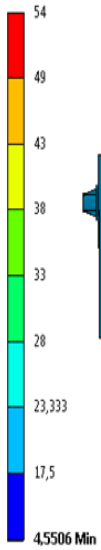
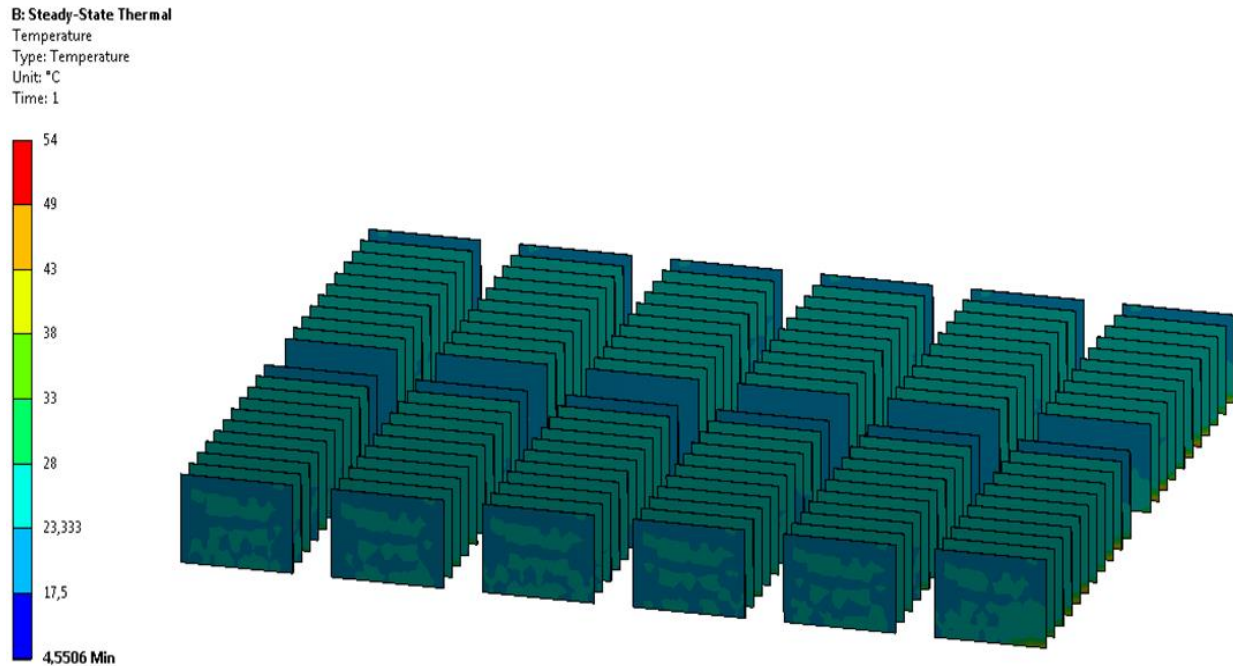


Figure 57 : The temperature field of cross-section inside the battery box



**Figure 58** : The temperature field of the thermal pad between battery cells

The simulation outcomes reveal that the internal temperature of the battery enclosure ranges from a maximum of 54 degrees Celsius (°C) to a minimum of 4.5506 degrees Celsius (°C) under the specified boundary condition, where the temperature of the battery cell is set to the peak value of 50 degrees Celsius (°C). Externally, the highest temperature observed outside the battery box is 23.333 degrees Celsius (°C). The area exhibiting the most elevated temperature field is situated within the battery module, primarily due to its direct interaction with the battery cells. The integration of a cooling plate demonstrates efficiency by lowering the temperature within the module from its peak at 54 degrees Celsius (°C) to a more subdued level within the lower section of the battery box, ultimately stabilizing at 28 degrees Celsius (°C). Additionally, the incorporation of a thermal pad serves to obstruct thermal conductivity among the battery cells housed within the module.

## 8 Conclusion

This Master's Thesis dealt with the innovation and design of the new battery box for electric vehicles. The primary goal has been to realize a lightweight design, and this aim has been pursued diligently through a comprehensive investigation of materials to construct a battery box that embodies resilience and functionality and exhibits a significant weight reduction.

The first part of this work starts with a comprehensive lecturer review of electric vehicle (EV) battery boxes employing lithium-ion batteries with a specific emphasis on thermal management and material selection for battery packs. Thermal management in electric vehicle (EV) batteries is

a critical aspect that plays a pivotal role in ensuring optimal performance, safety, and longevity of the battery systems. This part includes an explanation of the significance of thermal management for battery performance and safety, critical aspects and understanding of the factors influencing heat generation in lithium-ion batteries, and an overview of current thermal management solutions, including active and passive cooling methods. Indeed, the first part thoroughly explores the current status and innovative ideas concerning battery boxes for electric vehicles. This investigation comprehensively examines information extracted from patent and non-patent databases. This dual-source approach provides a rich repository of insights into cutting-edge technologies, designs, materials, existing challenges, and potential future directions within electric vehicle battery boxes. China has made substantial investments in the research and production of battery boxes for electric vehicles, as evidenced by the patent database. A geographical analysis of patent applicants reveals that China holds 520 patents in this domain. The examination of non-patent research indicates significant variations in the concepts of components and materials among various battery boxes in the market. The research highlights a growing trend towards adopting a multi-material approach, where the appropriate (often non-metallic) material is strategically applied to meet specific requirements, aiming to decrease the overall weight of the battery box. Following the lecturer's review and the compilation of comprehensive information from both patent and non-patent databases, five conceptual designs were subsequently developed. Employing the Analytic Hierarchy Process (AHP) for analysis, Concept 2 emerged as the preferred choice, achieving the highest score in the evaluation.

The battery box of Concept 2 is manufactured from a composite material, specifically carbon fiber, with the primary goal of achieving weight reduction while maintaining robust strength. Additionally, this enclosure exhibits notable properties such as excellent impact resistance, effective thermal conductivity, durability, and a prolonged lifespan, all attributed to the distinctive qualities of carbon fiber. The thermal management system of this battery box incorporates an aluminum liquid cooling plate alongside a thermal pad-grade silicon featuring a thermal conductivity of 1 (W/m.K). Within the pack are 12 battery modules, each housing 10 Samsung SDI 94 Ah battery cells. The box accommodates 120 battery cells, resulting in a total energy capacity of 41.4 kWh.

The simulation results from the battery box indicate that the internal temperature range within the battery enclosure spans from a maximum of 54 degrees Celsius ( $^{\circ}\text{C}$ ) to a minimum of 4.5506 degrees Celsius ( $^{\circ}\text{C}$ ) under the specified boundary conditions with the battery cell temperature set at its peak value of 50 degrees Celsius ( $^{\circ}\text{C}$ ). Externally, the highest temperature outside the battery box is 23.333 degrees Celsius ( $^{\circ}\text{C}$ ). The region with the most elevated temperature field is located within the battery module, primarily due to its direct interaction with the cells. The efficiency of the cooling plate integration is evident as it effectively reduces the temperature within the module. The temperature, which initially peaked at 54 degrees Celsius ( $^{\circ}\text{C}$ ), stabilizes at a lower level within the lower section of the battery box, reaching 28 degrees Celsius ( $^{\circ}\text{C}$ ). Furthermore, including a thermal pad impedes thermal conductivity among the battery cells housed within the module.

## References

- [1] Li Shui, Fangyuan Chen, Akhil Garg, Xiongbing Peng, Nengsheng Bao & Jian Zhang (2018). Structural and Multidisciplinary Optimization, pp. 331-347. Available from: <https://link.springer.com/article/10.1007/s00158-018-1901-y#Bibl>.
- [2] Garg A, Chen F, Zhang J (2016). State-of-the-art of designs studies for batteries packs of electric vehicles. IET Conf Electric Vehicle 29-6.
- [3] Abada S, Marlair G, Lecocq A, Petit M, Sauvant-Moynot V, Huet F (2016). Safety focused modelling of lithium-ion batteries. Journal of Power Sources, vol. 306, pp. 178-192.
- [4] Yi Jaeshin, Kim Ui Seong, Shin Chee Burm et al (2013). Modeling the temperature dependence of the discharge behavior of a lithium-ion battery in low environmental temperature. Journal of Power Sources, vol. 244, pp. 143-148, 201.
- [5] Z. Rao, S. Wang, M. Wu, Z. Lin, F. Li (2013). Experimental investigation on thermal management of electric vehicle battery with heat pipe. Energy Conversion and Management, vol. 65, pp. 92-97.
- [6] N. Sato (2011). Thermal behavior analysis of lithium-ion batteries for electric and hybrid vehicles. Journal of Power Sources, vol. 99, pp. 70-77.
- [7] N. Lewchalermwong, M. Masomtob, V. Lailuck and C. Charoenphonphanich (2017). Material selection and assembly method of battery pack for compact electric vehicle. IOP Conference Series: Materials Science and Engineering, Volume 297, 8th TSME-International Conference on Mechanical Engineering (TSME-ICoME 2017) 12-15 December 2017, Bangkok, Thailand. Available from: <https://iopscience.iop.org/article/10.1088/1757-899X/297/1/012019/meta>.
- [8] John Warner (2015). Handbook of Lithium-Ion Battery Pack Design, chemistry, Components, Types and Terminology, pp. 115-128, 133-135.
- [9] Shashank Arora, Weixiang Shen, Ajay Kapoor (2016). Review of mechanical design and strategic placement technique of a robust battery pack for electric vehicles. Available from: <https://www.sciencedirect.com/science/article/pii/S1364032116002483>.
- [10] Frey, Paul (Portola Valley C, Grace; Dustin (San Carlos, CA). Battery pack exhaust nozzle utilizing an SMA seal retainer. USA: Tesla Motors, Inc. (Palo Alto, CA); 2013.
- [11] Hermann, Weston Arthur (Palo Alto C. Rigid cell separator for minimizing thermal runaway propagation within a battery pack. USA: Tesla Motors, Inc. (Palo Alto, CA); 2012.
- [12] Watanabe K, Sato H, Hosaka K, Horie H. Battery structure. Google Patents; 2012.

- [13] Watanabe K, Abe T, Saito T, Shimamura O, Hosaka K, Sato H, et al. Battery structure, assembled battery, and vehicle mounting these thereon. Google Patents; 2012.
- [14] Iwasa; Makoto (Chigasaki J, Ogata; Shinya (Ebina, JP), Kadota; Hidetoshi (Yamato, JP), Hashimura; Tadayoshi (Machida, JP), Mori; Nobuhiro (Odawara, JP). Vehicle battery mounting structure. USA: Nissan Motor Co., Ltd. (Yokohama-shi, JP); 2010.
- [15] America NN. Nissan Leaf Battery Pack.
- [16] L. Brooke, Chevrolet Volt – development story of the pioneering electrified vehicle training, 2012 (2011), pp. 03-12.
- [17] N. Chambers, Chevy Volt and Nissan LEAF earn top marks on crash testsPluginCars: Recargo, Inc (2011).
- [18] QUERY: "BATTERY BOX" AND ELECTRIC VEHICLE. In Patent Inspiration. Available from: <https://app.patentinspiration.com/#report/E57FA8D843A6/filter>.
- [19] Google Patents. Available from: <https://patents.google.com/>.
- [20] Electric Vehicle Magazine. Available from:  
<https://chargedevs.com/newswire/consortium-of-auto-suppliers-launches-multi-material-ev-battery-casing-project/>.
- [21] Multi-Material Battery Enclosure From LION SMART. Available from:  
[https://lionsmart.com/en/multi-material-hv-battery-enclosure/#after\\_section\\_1](https://lionsmart.com/en/multi-material-hv-battery-enclosure/#after_section_1).
- [22] Battery Box From TRB Group. Available from:  
<https://www.compositesworld.com/articles/ev-battery-enclosure-inspires-material-process-innovations>.
- [23] Battery Enclosure Concept Multi-Material from continental Structural Plastics (CSP, Auburn Hills, Mich., U.S.). Available from :  
<https://www.compositesworld.com/news/continental-structural-plastics-named-pace-pilot-finalist-for-multi-material-battery-enclosure-concept>.
- [24] Research on the design process of car carbon fiber battery box. Available from:  
<https://inf.news/en/auto/xbf1bf8682c2157db3a0e9f9ee97d716.html>.
- [25] Kautex Textron and specialty chemical manufacturer Lanxess collaborated in a demonstration project to develop an all-plastic EV battery housing. Available from:  
<https://www.plasticsmachinerymanufacturing.com/injectionmolding/article/21254768/plastics-trim-ev-batteries-weight-boost-safety>.
- [26] Glass-Fiber PP EV Battery Pack Could Debut in 2024. Available from:  
<https://www.plasticstoday.com/automotive-mobility/glass-fiber-pp-ev-battery-pack-could-debut-in-2024>.

## **Appendix**

1. Drawing of Assembly Battery Box
2. Drawing of Assembly Battery Module
3. Drawing of Battery Box Body
4. Drawing of Battery Box Cover
5. Drawing of Battery Module Body
6. Drawing of Battery Module Cover
7. Drawing of Crash Structure
8. Drawing of Busbar Positive