



Master Thesis

Design of the production line at Faurecia Interior Systems

Study programme:

N0788A270005 Innovation and Industrial Engineering

Author:

Dhinakar Chandramohan

Thesis Supervisors:

Ing. František Koblása, Ph.D.

Department of Manufacturing Systems and Automation

Liberec 2024



Master Thesis Assignment Form

Design of the production line at Faurecia Interior Systems

Name and surname: **Dhinakar Chandramohan**
Identification number: S22000427
Study programme: N0788A270005 Innovation and Industrial Engineering
Assigning department: Department of Manufacturing Systems and Automation
Academic year: 2023/2024

Rules for Elaboration:

Design of the production line at Faurecia Interior Systems

The aim of this thesis is to optimize the production shopfloor layout at Faurecia Interior Systems BOHEMIA s.r.o. considering the gradual capacity decrease due to EOP.

1. The literature review focused on production, capacity management, adaptability in production and shop floor layout optimization.
2. Detailed analysis of the production portfolio within the Audi A6 line, including brought-out parts (BOP), trade parts, and spare parts.
3. Analysis of Layout, Current Approach and Capacity Decrease Requirements, Analysis of the need to adapt to gradual capacity decrease due to EOP (End of Production) scenarios: Data collection methods, including process timings, Internal BOP delivery loop calculations, packaging, frequency of the finished parts to the warehouse and the analysis of the current layout.
4. Definition of optimized layout. Outline the optimized layout with a focus on production and provide guidance on the best-suited layout for fluctuating production demands.
5. Verification and Validation of Optimized Layout.
6. Comparison of Current Status with Optimized Layout. Estimate the economic benefits, expenses, area availability for other projects, etc.

Scope of Graphic Work:

Scope of Report: 50-65

Thesis Form: printed/electronic

Thesis Language: english

List of Specialised Literature:

[1] IMAI, Masaaki. Gemba Kaizen: A Commonsense Approach to a Continuous Improvement Strategy. Second Edition. New York: McGraw Hill, 2012. ISBN 978-0071790352.

[2] JAMES A. TOMPKINS [ET AL.]. Facilities planning. 4th ed. Hoboken, NJ: John Wiley, 2010. ISBN 9780470444047

[3] BAUDIN, Michel. Lean assembly: the nuts and bolts of making assembly operations flow. New York: Productivity Press, 2002. ISBN 1-56327-263-6.

[4] IRANI, Shahrukh A., ed. Handbook of cellular manufacturing systems. New York: John Wiley, [1999]. ISBN 0-471-12139-8.

[5] BRITTON, Graeme Arthur; TORVINEN, Seppo. Design synthesis: integrated product and manufacturing system design. CRC Press, 2013. ISBN 9781138073746

Thesis Supervisors: Ing. František Koblasa, Ph.D.

Department of Manufacturing Systems and Automation

Date of Thesis Assignment: November 6, 2023

Date of Thesis Submission: May 22, 2024

L.S.

doc. Ing. Jaromír Moravec, Ph.D.

Dean

doc. Ing. Petr Lepšík, Ph.D.

study programme guarantor

Liberec November 6, 2023

Declaration

I hereby certify, I, myself, have written my master thesis as an original and primary work using the literature listed below and consulting it with my thesis supervisor and my thesis counsellor.

I acknowledge that my master thesis is fully governed by Act No. 121/2000 Coll., the Copyright Act, in particular Article 60 – School Work.

I acknowledge that the Technical University of Liberec does not infringe my copyrights by using my master thesis for internal purposes of the Technical University of Liberec.

I am aware of my obligation to inform the Technical University of Liberec on having used or granted license to use the results of my master thesis; in such a case the Technical University of Liberec may require reimbursement of the costs incurred for creating the result up to their actual amount.

At the same time, I honestly declare that the text of the printed version of my master thesis is identical with the text of the electronic version uploaded into the IS/STAG.

I acknowledge that the Technical University of Liberec will make my master thesis public in accordance with paragraph 47b of Act No. 111/1998 Coll., on Higher Education Institutions and on Amendment to Other Acts (the Higher Education Act), as amended.

I am aware of the consequences which may under the Higher Education Act result from a breach of this declaration.

Design of the Production Line at Faurecia Interior Systems

Abstract

The work exhibited in this thesis is designing a production line for the company Faurecia Interior Systems Bohemia s.r.o. in Mlada Boleslav. This thesis aims to optimize the production shopfloor layout considering the gradual capacity decrease due to End of Production. The production processes carried out were described and analysed using tools such as process diagrams, Spaghetti Analysis, and Value Stream Mapping. Based on the analysis, the Improve phase was defined and the production line was designed. The best solution was selected using multi-criteria analysis. The Witness 14 simulation software was used to simulate the shop floor model and achieve results that was required.

Keywords

End of Production, Design of Production Line, Simulation

Abstrakt

Práce představená v této diplomové práci se zabývá návrhem výrobní linky pro společnost Faurecia Interior Systems Bohemia s.r.o. v Mladé Boleslavi. Cílem této práce je optimalizace uspořádání výrobní haly s ohledem na postupné snižování kapacity v důsledku ukončování výroby. Prováděné výrobní procesy byly popsány a analyzovány pomocí nástrojů, jako jsou procesní diagramy, Spaghetti analýza a Value Stream Mapping. Na základě analýzy byla definována fáze zlepšování a byla navržena výrobní linka. Nejlepší řešení bylo vybráno pomocí multikriteriální analýzy. K simulaci modelu výrobní haly a dosažení požadovaných výsledků byl použit simulační software Witness 14.

Klíčová slova

Ukončování výroby, Návrh výrobní linky, Simulace

Acknowledgement

I am deeply grateful for the support from my university, which has provided me with an excellent opportunity to enhance my engineering skills. I want to express my heartfelt thanks to all the individuals who have inspired and guided me throughout my academic journey, enabling me to complete this diploma thesis successfully. Your assistance and advice have been invaluable to my studies.

I am highly indebted to **Ing. František Koblasa, Ph.D.**, Department of Manufacturing Systems and Automation. He convincingly encouraged and motivated me to be a professional and do the right thing even when the road got tough and bring out the best in me. With his constant guidance and support, the goal of this thesis was successfully attained.

I also want to express my gratitude to **Faurecia Interior Systems Bohemia Ltd.** for all the guidance and time they provided, which was very valuable. I also appreciate the support they extended to me by providing the necessary information for completing this thesis.

Furthermore, I wish to express my profound gratitude to my family and friends for their unwavering support and love throughout this journey's highs and lows. Their encouragement has been a constant source of strength.

Contents

- 1 Introduction..... 13**
- 2 Literature Review..... 14**
 - 2.1 Lean manufacturing 14
 - 2.1.1 The essence of lean manufacturing..... 14
 - 2.1.2 The goals of lean manufacturing..... 14
 - 2.2 DMAIC 15
 - 2.3 7 Types of Wastes 15
 - 2.4 Process Diagram 17
 - 2.5 Spaghetti Diagram 18
 - 2.6 Production Control Strategies..... 19
 - 2.6.1 Kanban 19
 - 2.6.2 CONWIP..... 20
 - 2.7 Multicriteria Analysis 21
 - 2.8 Simulation..... 22
 - 2.9 Line Balancing 23
 - 2.10 Value Stream Mapping 24
 - 2.11 Chronometry 26
 - 2.12 MOST 26
- 3 Faurecia Interior System 27**
- 4 Practical Part..... 29**
 - 4.1 Define 29
 - 4.1.1 Establishing the optimization plan..... 29
 - 4.1.2 Project Output Definition and Key Performance Indicators..... 30
 - 4.2 Measure..... 30
 - 4.3 Analyze..... 32
 - 4.3.1 Product Portfolio..... 32

4.3.2	Process Diagram	35
4.3.3	Spaghetti Diagram	38
4.3.4	Value Stream Map.....	40
4.3.5	Line Balancing	43
4.3.6	Simulation of the Current State.....	47
4.3.7	KPI Measurement for Current State	59
4.4	Improve.....	60
4.4.1	Spaghetti Diagram(Optimized).....	60
4.4.2	Spaghetti Diagram(Ideal).....	62
4.4.3	Value Stream Map (Optimized)	64
4.4.4	Value Stream Map (Ideal)	68
4.4.5	Line Balancing	70
4.4.6	Simulation of the Future State	74
4.4.7	KPI Measurement of Improved and Ideal State.....	78
4.5	Multicriteria Analysis	79
4.6	Control	81
5	Economical comparison.....	83
5.1	Labour Savings	83
5.2	Relocation Cost of Machinery	83
5.3	Return of Investment	83
6	Conclusion.....	84
7	References	85
	Attachment	87
A.1	Spaghetti Diagram (Current State).....	87
A.2	Spaghetti Diagram (Optimized State)	87
A.3	Spaghetti Diagram (Ideal State)	87

List of Figures

Figure 1:7 Types of Waste [6].....	16
Figure 2: Process Diagram [8]	17
Figure 3: Spaghetti Diagram [9].....	18
Figure 4: Kanban Card [11]	20
Figure 5: Line Balancing Diagram [27]	23
Figure 6: Example VSM [20].....	25
Figure 7: General -Levels of motion models.[21].....	26
Figure 8: FIS Plazy [23]	28
Figure 9: Instrument Panel [24]	32
Figure 10: Glove Box [25]	33
Figure 11: CDS [26].....	34
Figure 12 : Spaghetti Diagram (Current State)	39
Figure 13: VSM (Current State-IP_CS) [source: own].....	41
Figure 14:VSM (Current state-IP_PU) [source: own]	42
Figure 15:Worker Process Table (Press Covering).....	44
Figure 16:Worker Line Balancing-Press Covering (Current State).....	44
Figure 17:Worker Process Table (Welding-IP_CS).....	45
Figure 18:Worker Balancing Diagram (Welding-IP_CS).....	45
Figure 19:Worker Process Table (Welding-IP_PU)	46
Figure 20:Worker Balancing Diagram (Welding-IP_PU)	46
Figure 21:IP_CS Part Detail [source: own].....	48
Figure 22:IP_PU Part Detail [source: own]	48
Figure 23:Actions on Crate IP_CS[source: own].....	49
Figure 24:Detail Machine [source: own]	50
Figure 25:Detail Workstation [source: own]	50
Figure 26:Initial Buffer (IP_CS) [source: own]	51
Figure 27:Initial Buffer IP_PU[source: own].....	52
Figure 28:WIP_CS [source: own]	52
Figure 29:WIP_PU [source: own].....	53
Figure 30:WIP_FA [source: own].....	53
Figure 31:Shift_PC_WE [source: own]	54
Figure 32:Shift FA [source: own]	54
Figure 33:Simulation Current State [source: own]	55

Figure 34:Part Statistics (Current State) [source: own]	55
Figure 35:Machine Statistics (Current State) [source: own]	56
Figure 36:Buffer Statistics [source: own]	56
Figure 37:Labor Statistics [source: own]	57
Figure 38:Shift Statistics	57
Figure 39:Optimized Spaghetti Diagram [source: own]	61
Figure 40:Ideal Layout [source: own]	63
Figure 41:VSM (Optimized-IP_CS) [source: own]	64
Figure 42: VSM (Optimized-IP_PU) [source: own]	65
Figure 43:WIP Hanger Capacity [source: own]	66
Figure 44:Production Lead Time Comparison [source: own]	66
Figure 45:Workforce Comparison [source: own]	67
Figure 46:VSM (Ideal-IP_CS) [source: own]	68
Figure 47:VSM (Ideal-IP_PU) [source: own]	69
Figure 48: PLT Comparison (Ideal) [source: own]	70
Figure 49:Worker Process Table (Press Covering-Improved State) [source: own]	71
Figure 50:Worker Line Balancing-Press Covering (Improved State) [source: own]	71
Figure 51:Worker Process Table -Welding-IP_CS (Improved State) [source: own]	72
Figure 52:Worker Line Balancing-Welding-IP_CS (Improved State) [source: own]	72
Figure 53:Worker Process Table-Welding-IP_PU (Improved State) [source: own]	73
Figure 54:Worker Line Balancing-Welding-IP_PU (Improved State) [source: own]	73
Figure_55: New Simulation	74
Figure 56:Revised Buffer (WIP_CS)	74
Figure 57:Revised Buffer (WIP_PU)	75
Figure 58:Revised Buffer (WIP_FA)	75
Figure 59: Buffer Capacities Comparison	76
Figure 60: New Buffer Statistics	76
Figure 61:New Labour Statistics	77

List of Tables

Table 1: Measure 30

Table 2: Process Diagram IP_CS 35

Table 3: Process Diagram IP_PU 37

Table 4: KPI Measurement (Current State)..... 59

Table 5: Comparison Simulation..... 77

Table 6: KPI Measurement Optimized and Ideal State 78

Table 7: KPI matrix 79

Table 8: Normalized Matrix 80

Table 9: Weighted decision matrix 80

List of abbreviation

CONWIP	Constant Work in Process
CT	Cycle Time
DMAIC	Define Measure Analyze Improve Control
EOP	End of Production
IP_CS	Instrument Panel Cut & Sew
IP_PU	Instrument Panel Foamed Part
KPI	Key Performance Indicators
NVAT	Non-Value-Added Time
PLT	Production Lead Time
Tac	Process Time
Tbc	Setup Time
TT	Takt Time
VA index	Value Added Index
VAT	Value Added Time
VSM	Value Stream Mapping
WIP	Work in Progress

1 Introduction

In today's global market, enterprises must continuously improve efficiency, reduce costs, and maintain profitability to remain competitive amidst changing customer demands. Hence, it is crucial for companies to implement efficiency improvement methods. This is the reason why the topic of the thesis is crucial and relevant.

Manufacturing systems must become more flexible to respond to the rapidly changing economic environment. The manufacturing industry must produce high-quality products while minimizing production costs and maximizing resource utilization due to limited resources such as materials, machines, labour force, space, and other facilities.

The company Faurecia Interior Systems Bohemia Ltd is a part of the automotive interior manufacturing industry. It produces different automotive interior parts such as Instrument Panels, gloveboxes, Centre Consoles, etc. They have dedicated production zones for each client, such as Audi, BMW, Mercedes, and Seat.

The thesis focuses on optimizing the shopfloor layout of the Audi AU58X. The primary motivation for the optimization is the projected drastic decrease in demand for the product produced inside the production zone.

The current shop floor layout is studied, and the optimal layout is determined by utilizing different lean techniques and tools. A suitable layout is selected by validating the layouts using the multicriteria analysis.

This thesis aims to optimize the current shopfloor layout by primarily focusing on creating free spaces inside the shopfloor for warehousing purposes. Thesis work includes:

- Detailed analysis of the production portfolio within the Audi A6 line
- Analysis of Layout, Current Approach, and Capacity Decrease Requirements, Analysis of the need to adapt to gradual capacity decrease due to EOP (End of Production) scenarios.
- Data gathering, analysis, and measurement of current processes are necessary to optimize the layout.
- Definition of optimized layout. Outline the optimized layout, focusing on production and providing guidance on the best-suited layout for fluctuating production demands.
- Verification and Validation of Optimized Layout.
- Comparison of Current Status with Optimized Layout.

2 Literature Review

This chapter covers all the theoretical aspects necessary for understanding the practical implementation and conclusions of this thesis. It explains the various lean analysis tools and models that can be utilized to understand the current problem and select the optimal shop floor layout.

2.1 Lean manufacturing

Lean manufacturing is a production methodology that eliminates waste in a process, including non-value-added activities. It focuses on streamlining the production process by identifying and eliminating any steps or actions that do not add value to the final product or service.

2.1.1 The essence of lean manufacturing

Lean manufacturing is not a specific method but rather a philosophy of continuous improvement. It involves evaluating the manufacturing process to eliminate unnecessary costs, waiting, waste, and other inefficiencies. The basic idea is to identify activities that add value and those that do not. Value is defined as anything that the customer is willing to pay for. Although the lean manufacturing philosophy originated in the automotive industry, it can be applied to almost any field. This philosophy includes various tools to detect and eliminate waste, some of which will be described in more detail and used later in the thesis.

2.1.2 The goals of lean manufacturing

- Improving the quality of products is crucial for any business. It not only enhances the quality of the overall process layout but also eliminates scrap, which reduces the wastage of material and saves time by avoiding machine repairs. Quality improvement leads to efficient utilization of company resources, which is highly beneficial.
- Cost reduction is another crucial aspect of business operations. To achieve this, businesses should reduce input costs to produce the same number of products or increase the number of products with the exact cost value. This will increase the efficiency of the enterprise and improve its profitability.
- Shortening the production cycle is also essential. The production cycle is the time to recover the money invested in a single job, which includes receiving the order, ordering the material, production, delivery, and payment. By reducing this cycle, businesses can increase the number of products in the same amount of time and respond more quickly to customer requirements, which is essential for success [1].

2.2 DMAIC

DMAIC, which stands for Define-Measure-Analyse-Improve-Control, is a structured approach commonly used in process improvement within the framework of Six Sigma methodologies [2].

D - Define - In this initial phase, the goals of the improvement activity are clearly outlined. This involves defining the problem to be addressed, setting project objectives, and establishing the scope of the project. It is essential to identify requirements and expectations during this phase, often referred to as Critical to Quality (CTQ) in Six Sigma [3].

M - Measure - The Measure phase is crucial in the DMAIC methodology. Its primary objective is to evaluate the current state of the process under investigation. This involves defining critical process metrics, establishing baseline performance, and collecting relevant data to comprehensively understand the process's key characteristics. The Measure phase provides a foundation for the DMAIC strategy by identifying areas for improvement and informing decision-making throughout the subsequent analysis [4].

A - Analyse - Once data has been collected, the analysis phase focuses on identifying the root causes of the issues affecting the process performance. Various tools and techniques are employed to analyze the data and determine factors influencing the process behaviour. The goal is to gain insights into why the process is not meeting the desired objectives [3].

I - Improve - In the improvement phase, solutions are developed and implemented to address the root causes identified during the analysis phase. This stage involves designing and executing changes to enhance process performance and meet the defined objectives. Continuous improvement is a key aspect of this phase [4].

C - Control - The final phase, control, involves establishing a system to ensure that improvements are sustained over time. Monitoring and controlling the process post-implementation is essential to verify that the changes are effective and that the process remains stable. This phase aims to standardize the improvements and prevent regression to previous performance levels [3].

2.3 7 Types of Wastes

In process optimization and efficiency enhancement, the TIMWOOD framework offers valuable insights into recognizing and addressing inefficiencies that can hinder the smooth operation of processes. The acronym TIMWOOD represents seven distinct types of waste that can be prevalent within manufacturing and operational contexts. By acknowledging these sources of waste and systematically mitigating them, organizations can streamline their processes, reduce costs, and improve overall productivity.

1. **Transportation:** In a manufacturing plant, the raw material undergoes a series of operations before transforming into a finished product. Transferring the material from one operation to another doesn't add value to the product. Unnecessary movement of material leads to a loss of time and incurs additional costs, such as the cost of operating forklifts and conveyor belts.

2. **Inventory:** During production, the flow of materials may not move seamlessly and may pause before reaching various processes. This can result in the accumulation of inventories of semi-finished and finished products. The more frequently the material flow stops, the larger the inventories become. Excessive inventory will lead to additional costs and require more resources to manage.
3. **Motion:** In a worker's workday, only a tiny fraction of their actions contribute to the final product. Lean manufacturing employs various techniques to eliminate unnecessary movements, such as MOST, a snapshot of the workday, etc.
4. **Waiting:** Waiting waste occurs when there is a delay or pause between tasks, leading to a halt or slow progress in processes. This can result in longer lead times, decreased throughput, and employee dissatisfaction. To prevent waiting waste, it is essential to streamline the process flow, remove bottlenecks, and ensure that tasks are performed smoothly without unnecessary interruptions.
5. **Overproduction:** Overproduction occurs when a company produces more products than it can sell. This often happens when a company tries to utilize its production capacity fully. However, overproduction can result in increased costs for storage, transportation, and administration. Therefore, companies must manage their production volumes efficiently to avoid overproduction and associated costs.
6. **Over Processing:** Wastage can also be in a poorly organized technological process. For example, if the line is in the wrong place, this leads to a crossing of material flow.
7. **Defects:** The production process should not yield any defective products as it leads to additional resources being utilized to repair the defect, which increases the cost of production [5].

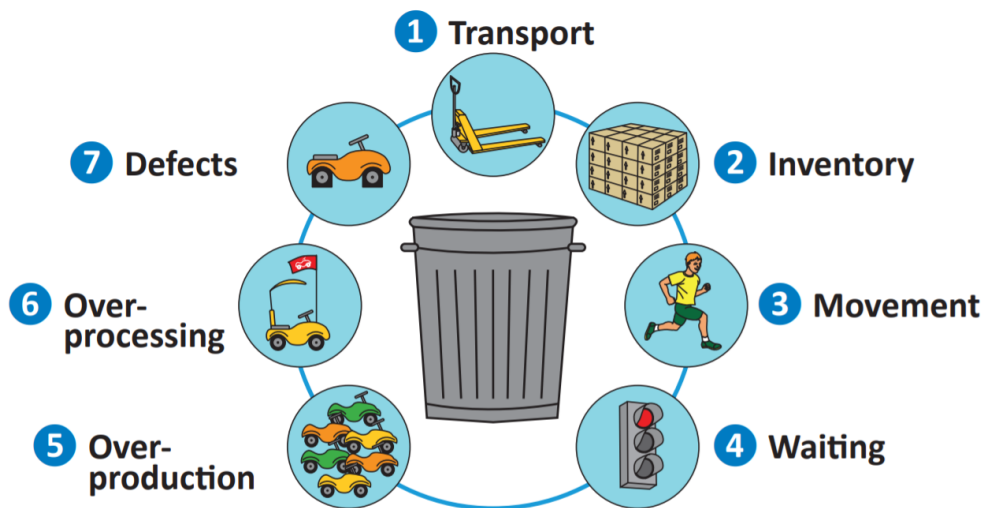

Figure 1:7 Types of Waste [6]

2.4 Process Diagram

Process diagrams play a crucial role in industrial engineering as they visually represent processes, systems, and workflows. Besides that, process diagrams provide a structured and intuitive depiction of complex systems, helping engineers to identify inefficiencies, bottlenecks, and improvement opportunities. Moreover, they aid in standardizing procedures, improving quality control, and promoting operational transparency within organizations.

- Nodes or boxes represent the process's many steps or stages. Usually, a summary of the process is used to mark each node.
- Arrows or lines: This shows how the process moves from one phase to the next. Depending on the process being diagrammed, the direction of the arrows may be from left to right, top to bottom, or in any other way.
- Branches: A process may occasionally contain several branches or routes that result in various results. These can be shown using various colour schemes, dashed lines, or other visual indicators.
- Both inputs and outputs may be present at different stages, depending on the represented process. Arrows or other symbols can be used to represent these [7].

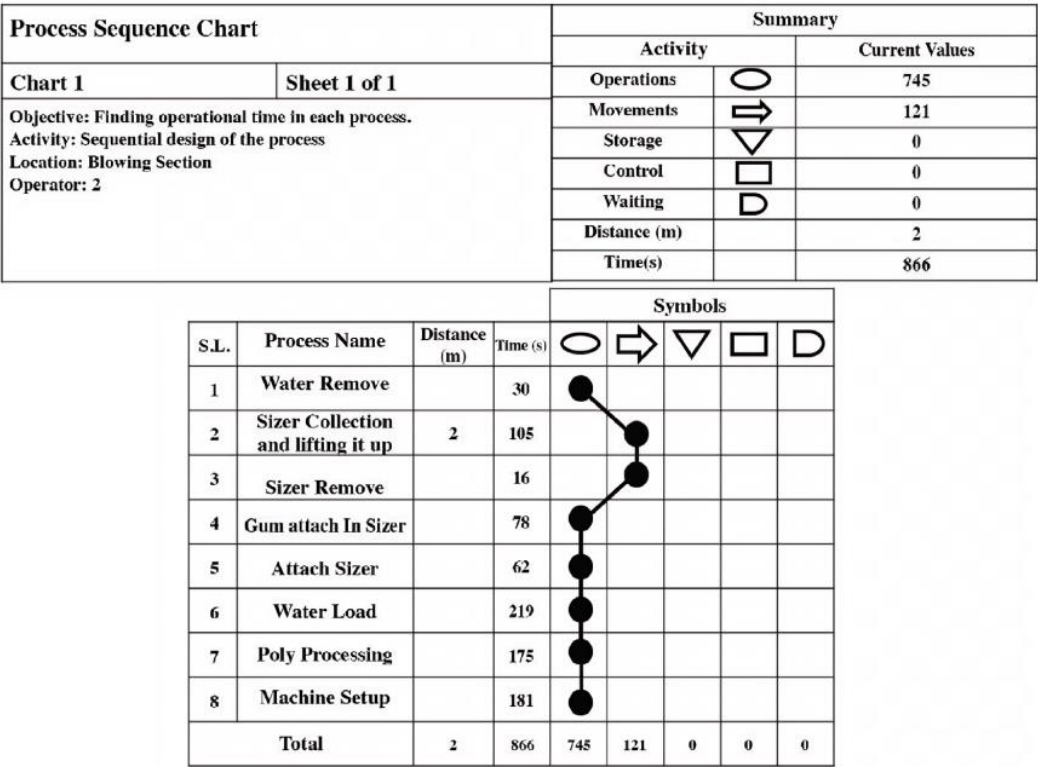

Figure 2: Process Diagram [8]

2.5 Spaghetti Diagram

The Spaghetti Diagram, also known as the Flow Process Chart, is a visual tool used in process analysis to track and understand the movement of people, materials, or information within a workspace. This technique helps identify inefficiencies, congestion points, and opportunities for improvement in a process.

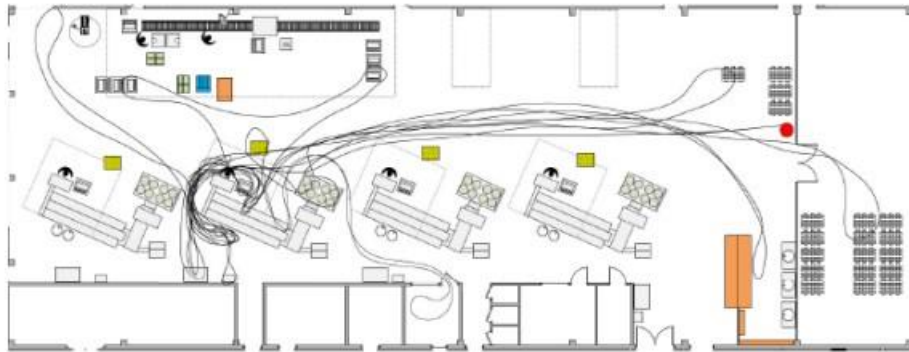

Figure 3: Spaghetti Diagram [9]

Using a Spaghetti diagram, we can visually track the movement path of products, workers, intermediate products, and other items. We can even use different colours to distinguish between products, workers, or technical means and track their movement at different times. After analysing the diagram, we can identify the length, number of movements, overlapping and crossing movements, and their characteristics based on the chosen classification. By applying the results of the Spaghetti diagram, we can identify inefficient movements and ineffective areas, reduce the number of staff needed, and make changes to the work organization or workstation layout [9].

Also, an ideal material flow should prioritize these six characteristics:

1. **Shortest/Fastest Path:** Material movement should follow the most direct and time-efficient route throughout the process.
2. **No Crossing:** Minimize or eliminate situations where material flows intersect to prevent congestion and bottlenecks.
3. **Sufficiently Defined:** The flow path should be clearly marked and well-understood by everyone involved, ensuring smooth and predictable movement.
4. **One-Way Flow:** Whenever possible, establish a one-way flow system to avoid backtracking and potential collisions.
5. **Wide Enough:** The designated flow path should be sufficiently wide to accommodate the volume and type of material being transported without creating bottlenecks or obstructions.
6. **Fluent and Continuous:** Strive for a smooth and uninterrupted flow with minimal stoppages and delays to optimize overall production efficiency [22].

2.6 Production Control Strategies

Production control strategy contains the methodologies and techniques employed to manage and regulate manufacturing processes effectively. In contemporary business practices, production control strategies are pivotal for ensuring efficient resource utilization, minimizing lead times, and meeting customer demands promptly. Common types include Just-in-Time (JIT), Kanban, Total Quality Management (TQM), and Six Sigma, CONWIP. We will discuss Kanban and CONWIP in detail because these strategies align with our objectives.

2.6.1 Kanban

Toyota developed this KAN-card and BAN-signal system, and this is a suitable tool for shop floor management and production planning. The system works in such a way that a supplier, warehouse, or production only uses components needed in each quantity and at a given time to eliminate surplus inventory. This system will produce or deliver only the required components of the received Kanban card and blank container, indicating that additional parts will be required for production. Higher production of goods can be achieved using the Kanban method.

Basic rules of the Kanban system:

- Subsequent process must take parts from the previous process according to the data of the corresponding, kanban card.
- Allocation of parts production without a Kanban card is not allowed.
- Taking over low-quality parts from a previous operation is not allowed.
- Production is stopped immediately if a non-conforming product is found.
- Pallets with parts can only be moved with a kanban card.
- The quantity of Kanban cards in circulation must align with the final production needs.

Basic types of Kanban:

- one-card system and two-card system.
- Internal and external.
- Electronic and paper [10].



Figure 4: Kanban Card [11]

2.6.2 CONWIP

Constant Work in Process (CONWIP) is a pull-oriented production control system aiming to minimize Work-In-Process (WIP) inventory while maintaining smooth production flow. Unlike traditional push systems that dictate production based on forecasts, CONWIP uses a fixed number of authorization cards, often physical or digital, to control the flow of materials and jobs.

Basic Rules:

1. **Limited WIP:** A predefined number of CONWIP cards dictate the maximum allowable WIP in the system.
2. **Authorization to Produce:** Each CONWIP card authorizes the production of a single unit.
3. **Card Movement:** A card accompanies a unit throughout the production process. The card is released upon completion and becomes available for a new unit at the starting point.
4. **Pull System:** Production is triggered by the availability of a CONWIP card, ensuring downstream demand pulls materials through the system.

Basic CONWIP Types:

- **Single-Line CONWIP:** This is the most basic form, suitable for single-stage production lines with minimal variations.
- **Multiline CONWIP:** This applies to production processes with multiple lines or stages. Here, CONWIP cards manage WIP levels at each stage or for specific groups of machines.
- **Feeding CONWIP:** Used for feeding lines or supplying components to a main assembly line. The feeding line operates under its own CONWIP limit, ensuring a steady flow of materials to the main line [12].

2.7 Multicriteria Analysis

Multicriteria analysis is a decision-making tool that simultaneously considers multiple factors or criteria when evaluating alternatives. In selecting an optimal layout for a facility, multicriteria analysis involves assessing various factors to make informed decisions.

Multicriteria analysis allows decision-makers to weigh different layout options against these criteria when choosing an optimal layout. Each layout alternative is evaluated based on its performance across the criteria, and a weighted score is assigned to reflect its relative importance. By considering multiple criteria, multicriteria analysis helps identify the layout that best aligns with the organization's objectives and priorities.

When making decisions involving multiple criteria, assigning weights to each criterion is crucial. These weights reflect the relative importance of each factor in the final selection. Here is a breakdown of three popular weighting methods:

1. Order Method:

This is a simple and quick approach where we rank the criteria in order of importance, from most to least important. However, it does not provide any specific weight values. It is suitable for situations where a clear hierarchy exists between criteria.

2. Scoring Method:

Here, we assign a score to each criterion based on its relative importance. The scoring system can be flexible, for example, assigning a score of 1 to the least essential criterion and progressively higher scores (e.g., 3, 5, 7) for more critical ones. This method offers slightly more detail than the Order Method but still lacks precise weight values.

3. Pairwise Comparison of Criteria - Fuller Method (Fuller Triangle):

This method directly compares each pair of criteria to determine their relative importance. It works by:

- Construct a triangular table (Fuller Triangle) with all criteria listed on the top row and down the left side (excluding duplicates).
- By comparing two criteria (i, j) for each cell, decide which criterion (i or j) is more important. Mark the cell accordingly (e.g., "i" if criterion i is more important).
- If the criteria are considered equally important, leave the cell blank.
- After completing the comparisons, count the times each criterion is marked as "more important" in its row. This count represents the relative weight of each criterion [13] [14].

2.8 Simulation

Simulation refers to the process of creating a model of an actual or proposed system using specialized computer software. The aim is to identify and understand the system's limiting factors or predict its future behaviour. Simulation can be applied to any system that can be quantified using equations or rules. It is a powerful and critical tool that enables one to test various models, plans, or proposals without experimenting with a natural system. This is particularly beneficial because experimenting with a natural system can be expensive, time-consuming, or impractical. Since simulation is such a powerful tool for understanding complex issues and supporting decision-making, several different methods and tools are available.

In the field of layout optimization, simulation software has emerged as a powerful tool. It creates a virtual environment for testing and evaluating different layout configurations before any physical implementation occurs. This empowers a more informed decision-making process, yielding significant advantages:

1. Simulation drastically reduces costs by eliminating the need for expensive physical reconfigurations, saving time and resources.
2. It acts as a bottleneck and inefficiency identifier within the layout, allowing for workflow and material handling optimizations.
3. Simulation facilitates enhanced capacity planning by assessing a layout's ability to handle future growth or fluctuating demand scenarios.
4. By identifying and addressing potential problems within a virtual space, simulation minimizes the risk of disruption and production downtime during physical layout changes.

Some of the tools are,

- Spreadsheets
- Discrete Event Simulators
- Agent-Based Simulators
- Continuous Simulators,
- Hybrid Simulators.

Simulation is a tool for decision-making and support. Simulation software evaluates, compares, and optimizes alternative designs, plans, and policies [15] [16].

2.9 Line Balancing

Line balancing is a key strategy for achieving excellence in lean manufacturing. It involves carefully assigning tasks to workstations, with the goal of achieving a smooth flow of materials and minimizing idle time for workers and machines. This approach helps to minimize cycle time, maximize throughput, reduce work-in-process (WIP) inventory, and improve overall efficiency. By optimizing production lines in this way, manufacturers can expedite production, increase output, and save costs.

Line balancing is influenced by multiple factors.

- Takt time, dictated by customer demand, determines the required production rate.
- Individual cycle times within the production process need to be meticulously analysed.
- The line balance ratio is a critical metric, reflecting the evenness of workload distribution across workstations.

There are different methods for line balancing. One approach is to use manual techniques that involve analysing task times and assigning them to workstations using charts and spreadsheets. However, computerized line balancing software can streamline the process and optimize line configurations for more complex scenarios [15].

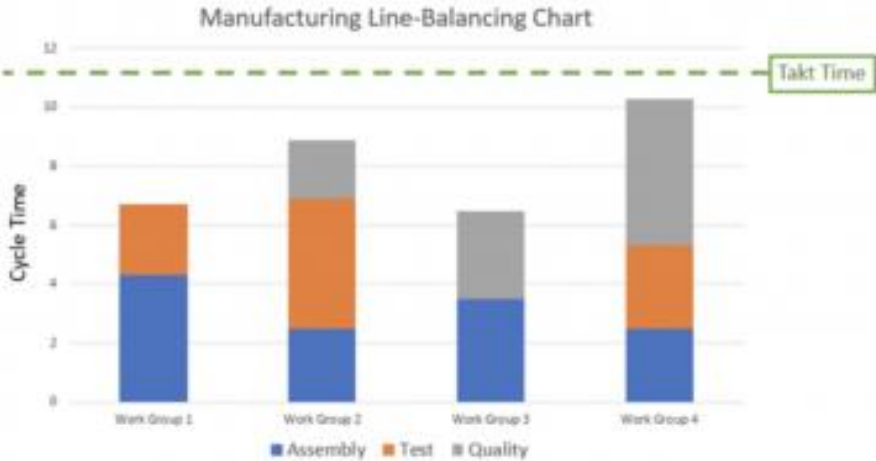

Figure 5: Line Balancing Diagram [27]

2.10 Value Stream Mapping

Value Stream Mapping (VSM) is a lean management tool that enables organizations to visualize and analyze the flow of materials and information needed to deliver a product or service to a customer [17]. It involves mapping out the current state of processes, identifying areas of waste and inefficiency, and designing a future state that optimizes performance [18].

Key Performance Indicators (KPIs) in Value Stream Mapping

In VSM, KPIs are essential metrics to evaluate the process's health and assist in decision-making during the improvement journey. Selecting suitable KPIs depends on the VSM initiative's objectives, evaluation process, and intended results. Here, we discuss a selection of KPIs commonly employed in the Value Stream Mapping process:

1. **Cycle Time:** Cycle time is the time to complete a single process cycle. Measuring cycle time at various stages of the value stream helps identify bottlenecks and areas of inefficiency. Reducing cycle time signifies improved throughput and shorter lead times for customers.
2. **Lead Time:** Lead time represents the time it takes for a customer order to be fulfilled from the point of initiation. It encompasses the time required for processing, manufacturing, and delivery. It is monitoring lead time aids in meeting customer expectations and enhancing responsiveness.
3. **Process Time:** Process time is required to perform a specific task or activity. Analysing process time assists in pinpointing activities that consume excessive time and resources, thereby enabling targeted improvements.
4. **First-Pass Yield:** First pass yield measures the proportion of completed products or services without rework or corrections. A high first-pass yield indicates a streamlined process with fewer defects and reduced waste.
5. **Takt Time:** Takt time denotes the rate at which products must be produced to meet customer demand. Aligning production with takt time ensures optimal resource utilization and minimizes overproduction.
6. **Changeover Time:** Changeover time refers to switching between different product or process configurations. Reducing changeover time contributes to increased flexibility and the ability to respond swiftly to changing customer requirements.
7. **Work in Progress (WIP):** WIP quantifies the number of unfinished tasks or products at various process stages. Managing WIP levels is crucial to prevent overproduction, reduce lead times, and enhance flow.

- Value-Added Ratio: The value-added ratio compares the time spent on value-added activities to the overall process time. A higher value-added ratio indicates a more efficient process with a reduced proportion of non-value-added activities.[19]

Selecting and tracking these KPIs during the VSM process empowers organizations to identify areas of improvement, set targets for enhanced performance, and gauge the impact of implemented changes. Additionally, KPIs provide a data-driven foundation for continuous improvement efforts, ensuring that the benefits of VSM are sustained over time.

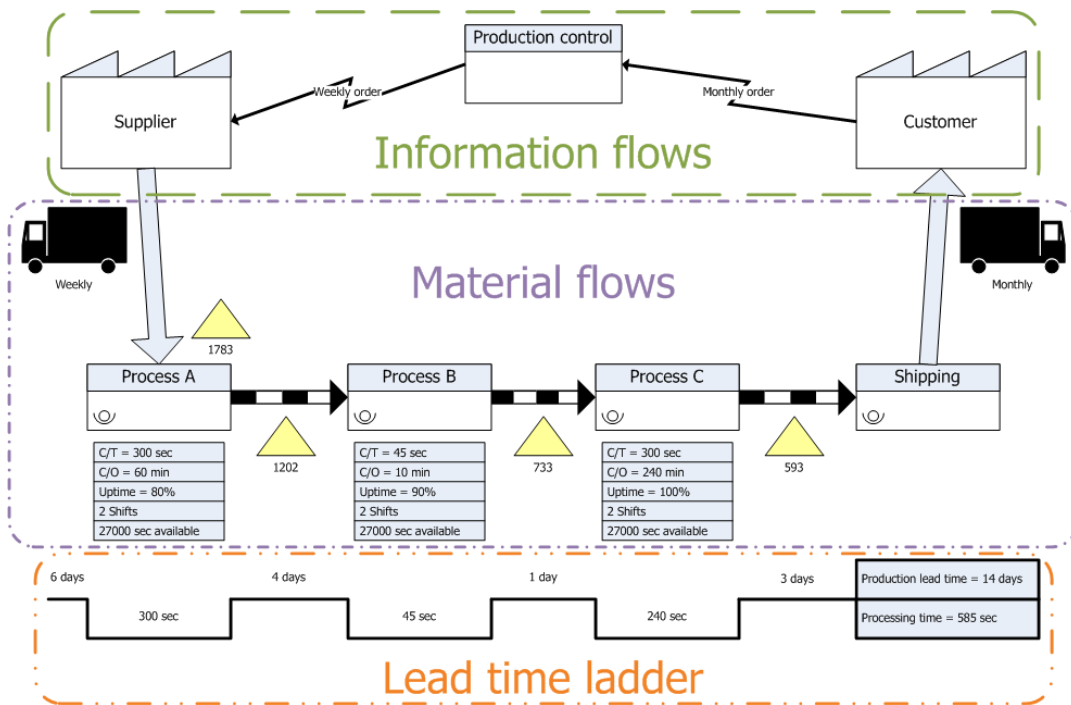

Figure 6: Example VSM [20]

2.11 Chronometry

Chronometry is the science of measuring time taken to complete operations. There are three main types of chronometry used in work study:

1. Continuous timing: This method measures the time of all operations throughout the entire process.
2. Selective timing: This method focuses on measuring the actual time consumption for specific, preselected elements of the operation. These elements can be regularly or irregularly repetitive, but they should be previously identified tasks.
3. Step chronometry: This method is used to measure the duration of very short, regularly recurring elements within a larger operation. Here, the times of entire groups of work tasks are measured, and additionally, the time taken for each individual element within the group is calculated [21].

2.12 MOST

Maynard Operation Sequence Technique (MOST) is a predetermined motion time method commonly used in industrial settings to establish standard times for tasks performed by workers. It involves organizing tasks hierarchically based on their temporal properties to streamline work measurement and optimize productivity. By adopting MOST, organizations can address operational challenges and improve productivity by implementing lean and productivity enhancement strategies. The technique plays a vital role in work system design, facilitating the smooth functioning of assembly lines and enhancing production efficiency. By systematically timing sub-operations or movements, MOST contribute to accurate work measurement data and improved resource utilization in industrial processes [22].

General Move						Action Distance Extender Values			
Index x 10	A Action Distance	B Body Motion	G Gain Control	P Placement	Index x 10	Index	Steps	Feet	Meters
0	≤ 2 in. (5 cm)			Pickup Toss	0	24	11 – 15	36	12
1	Within Reach		GRASP Light Object Light Objects Simo	PUT Lay Aside Loose Fit	1	32	16 – 20	50	15
3	1 – 2 Steps	Sit or Stand	GET Light Objects Non-Simo Heavy or Bulky Blind or Obstructed	PLACE Loose Fit Blind or Obstructed Adjustment Light Pressure Double Placement	3	42	21 – 26	65	20
6	3 – 4 Steps	Bend and Arise	Disengage Interlocked Collect	POSITION Care or Precision Heavy Pressure Blind or Obstructed Intermediate Moves	6	54	27 – 33	83	25
10	5 – 7 Steps	Sit or Stand with Adjustments			10	67	34 – 40	100	30
16	8 – 10 Steps	Stand and Bend Bend and Sit Through Door			16	81	41 – 49	123	38
						96	50 – 57	143	44
						113	58 – 67	166	51
						131	68 – 76	195	59
						152	79 – 90	225	69
						173	91 – 102	255	78
						196	103 – 115	286	88
						220	116 – 128	320	98
						245	129 – 142	355	108
						270	143 – 156	395	120
						300	159 – 174	435	133
						330	175 – 191	478	146

Figure 7: General -Levels of motion models.[21]

3 Faurecia Interior System

Faurecia is currently the world's sixth-largest manufacturer and supplier of automotive components. The company was founded in 1914 by Bertrand Faure, a French entrepreneur who set up the first workshop to manufacture tram and metro seats for Paris.

In 1929, the company obtained a patent license to manufacture seats for all public transport means. Faurecia, as we know it today, was created in 1997 by the merger of two companies, Bertrand Faure and Ecia. Combining the names of these companies gave the current name of Faurecia.

Today, the company is one of the most important suppliers to the automotive industry.

This success is due to all its business activities groups, which include development, research, and production:

- Automotive Seating: engaged in the manufacture of seating systems.
- Emission Control Technologies: engaged in the manufacture of exhaust systems, emission control systems, catalytic converters, and distributors.
- Interior Systems: manufactures dashboards, Glovebox, Footwell, center consoles, and Carrier Bezel.
- Automotive Exteriors: Manufactures bumpers, fenders, spoilers, front ends, engine cooling systems, floors, roof structures, and towing devices.

The company comprises 330 plants spread over 34 countries. As a result, it has a dense network around the world and many important customers in the automotive industry.

Significant partners include car companies such as Audi, Citroën, Ford, Mercedes, Opel, Skoda, Volvo, VW.

Faurecia Interior Systems

Faurecia Interior Systems Bohemia was founded in 1995 near Mladá Boleslav, in an industrial zone at Plazy 100, 293 01 Mladá Boleslav. At this address, the company has its production facilities, warehouses, and offices.

This plant is oriented toward producing automotive interiors. It currently produces various interior parts for major car manufacturers such as Audi, Citroën, Ford, Mercedes, BMW, and Skoda.

The plant is equipped with many production technologies, such as:

- Plastic Injection Moulding
- Painting of plastics
- Flocking
- Slush skin production.
- Foaming
- Moulding
- Thickening
- Welding



Figure 8: FIS Plazy [23]

4 Practical Part

The practical part of the study focuses on fulfilling the objective of the thesis by using the methods described in the theoretical part. The **DMAIC** approach has been chosen to achieve the tasks of the thesis.

4.1 Define

One of the principles of successful problem-solving is a well-defined goal. This thesis aims to optimize the shop floor layout of the Audi Au58x production zone of the Faurecia Interior Systems. The primary reason for the optimization is based on the fact that demand for the parts produced within the zone is projected to be drastically reduced, and it may lead to the possible end of production.

This significant decrease necessitates a proactive approach to optimize the shop floor layout. Our primary objective is to leverage this optimization to achieve two key goals:

1. Reduce resource allocation by streamlining the layout and eliminating inefficiencies.
2. Create valuable space within the shop floor to accommodate warehousing needs.

By strategically redesigning the layout, the aim is to ensure the production facility remains adaptable and cost-effective in the face of these changing production demands.

4.1.1 Establishing the optimization plan

In the defining stage, it is essential to have an optimization plan that outlines all the necessary steps to achieve the objective.

For the given assignment, the plan is as follows.

1. Familiarization with the products produced by a product portfolio analysis.
2. Introduction to material flow using methods.
 - Process Diagram
 - Spaghetti diagram
 - VSM
3. Uncovering the inefficiency inside the shop floor.
4. Detailed analyses of the problems discovered.
5. Suggestions for improvement.
6. Evaluation of results.

4.1.2 Project Output Definition and Key Performance Indicators

To clearly define the project output, several key performance indicators (KPIs) will be monitored and analysed. These KPIs include:

- **Production Area:** Evaluate the potential reduction in production area required due to lower demand.
- **Number of Workers:** Assess the optimal workforce size considering the reduced workload.
- **Product Travel Distance:** Minimize the distance parts travel within the production zone to improve efficiency.
- **Production Lead Time:** Minimize the total time the product takes to manufacture from start to finish.
- **Work-in-Progress (WIP):** Reduce WIP buffer levels to minimize resource allocation and improve production flow.

By focusing on these KPIs, the project will define a new shop floor layout that is both cost-effective and adaptable to the changing production demands of the Audi Au58x zone.

4.2 Measure

The Measure phase is crucial in the DMAIC methodology. Its primary objective is to evaluate the current state of the process under investigation. This involves defining critical process metrics, establishing baseline performance, and collecting relevant data to comprehensively understand the process's key characteristics. The Measure phase lays the groundwork for subsequent analysis, helping pinpoint improvement areas and providing a solid foundation for making informed decisions throughout the DMAIC journey.

Table 1: Measure

KPI Code	KPI	Criteria Abbreviation
101	Production Lead Time	PLT
102	Production Area	PA
103	No of Workers	workers
104	Products Travelling distance	PD
105	Cycle Time	CT

1. Production Lead Time (PLT):

Given the expected low production volume, the data collection frequency for production lead time (PLT) will be adjusted.

Data Collection Method: Production lead time will be measured by analyzing Value Stream Mapping (VSM) data and conducting simulations. These methods provide valuable insights even for low-volume production.

Frequency: The data collection period will be extended (e.g., several weeks or months). This ensures capturing enough lead time data for meaningful analysis and bottleneck identification.

2. Production Area:

Data Collection Method: The production area layout will be measured directly from the company's AutoCAD file.

Frequency: This is a one-time measurement since the layout is unlikely to change frequently unless a major reconfiguration is planned. The data will be revisited during the "Analyze" phase to explore potential layout improvements that could optimize production flow, even for lower volumes.

3. Number of Workers:

Data Collection Method: A manual headcount will be conducted at the beginning of each shift to establish a baseline staffing level under current demand conditions.

Frequency: As demand decreases, the frequency of headcounts will increase. This might involve:

- **Daily Headcounts:** Daily monitoring ensures appropriate staffing levels to meet reduced demand and avoid overstaffing.
- **Real-time Adjustments:** In highly dynamic situations, real-time adjustments based on actual production needs and incoming orders might be considered.

4. Cycle Time:

Data Collection Method: Data From the company, Stopwatch Study

Frequency:

- A one-time stopwatch study was conducted during the **morning shift** to provide a snapshot of cycle times.
- To gain a more comprehensive picture, the analysis also includes cycle time data provided by the company for a more extended period (e.g., **one day**). This combined approach will allow for the identification of variations in cycle time and potential causes, such as machine differences, operator skill levels, or product complexity. By understanding these variations, the analysis can inform targeted strategies for cycle time improvement.

4.3 Analyze

The Analyze phase is a vital step in the Six Sigma methodology, which helps to spot inefficiencies in the shop floor and determine if they are the root causes of defects. This phase focuses on various lean tools, including Product Portfolio, process diagram, spaghetti diagram, VSM, and Simulation.

4.3.1 Product Portfolio

The Audi Au58x production zone within the Faurecia facility manufactures four key Automotive interior components, each playing a crucial role in the vehicle's interior design and functionality. This sub-section will focus on these components and their production processes. The figures used are for illustrative purposes only and do not represent the actual parts manufactured in the company.

1. Instrument Panel:

The instrument panel, also known as the dashboard, is the primary component forming the driver-facing area of the vehicle's interior. The production process for the dashboard involves the following:

- **Injection Moulding**
- **Laser Cutting**
- **Welding**
- **Flaming**
- **Foaming**
- **Adhesives**
- **Punching**
- **Milling**
- **Oven**
- **Flocking**
- **Assembly**



Figure 9: Instrument Panel [24]

2. Glovebox:

The glove box provides a designated storage space for the driver and passengers within the vehicle. Its production process often shares some similarities with the dashboard but might involve additional steps. The production process involves the following:

- **Injection Moulding**
- **Welding:** Two types of welding might be employed depending on the specific design:
 - **Lid Welding:** A ultrasonic welding technique is used to join different parts of the glove box lid, ensuring a strong and aesthetically pleasing finish.
 - **Frame Welding:** A resistance welding technique is used to securely weld the frame components of the glove box, providing a robust structure for the compartment.
- **Flocking**
- **Assembly Process**



Figure 10: Glove Box [25]

3. Cover Driver Side

This component is a trim piece covering specific areas on the driver's side of the instrument panel. Its production process might involve any of the core processes mentioned earlier, depending on the design and complexity of the cover: The production process involves the following:

- **Injection Moulding**
- **Welding** (Ultrasonic, Resistance)
- **Flocking**
- **Assembly Process**



Figure 11: CDS [26]

4. Main Unit Footwell

The main unit footwell is a critical plastic part that forms the floor of the driver and passenger footwells within the vehicle cabin. This injected plastic component is crucial in occupant comfort, safety, and overall vehicle aesthetics. The production process involves the following:





























































- **Injection Moulding**
- **Punching**
- **Ultrasonic Welding**
- **Assembly Process**

4.3.2 Process Diagram

A process flow diagram (PFD) was created to visualize the material flow throughout the system. This analysis aided in identifying inefficiencies, bottlenecks, and improvement opportunities within the process.

The process 1 number does not have an ID because the injection machine is not on the shop floor of the au58x production zone, and it is not part of the optimization.

Table 2: Process Diagram IP_CS













































No	Description of activity	Workstation / Machine	Operation	Transport	Inspection	Delay/ Waiting	Storage	Time (Min)
1	Injecting The Carrier Upper C&S LHD/RHD	-						1.45
2	Transporting The Injected part to Au58x Zone	-						1.10
3	Weakening and Cutting Hole by Laser	LM_01						1.51
4	Transporting the injected chute Chanel C&S,LHD/RHD	-						3.0
5	Welding the Carrier Upper+chute + cluster in the IR machine	WM_02						1.12
6	Gluing the carrier + spacer C&S using a robot	GM_03						2.1
7	Drying the carrier + spacer C&S	O_04						2.2
8	Manually positioning the Foam/Fabric	WS_01						1.89
9	Inspection The spacer using Camera	WS_02						0.35
10	Sticking Machine	WS_03						0.50
11	Pre-Positioning Foam/Fabric (A1.1)	WS_04						1.78
12	Pre-Positioning (A2.1)	WS_05						2.00































13	Pre-Positioning Foam/Fabric B2.1	WS_06						2.00
14	Inspection The cover using Camera	WS_07						0.18
15	Press Covering including edge folding	PCM_05						2.58
16	Manual Edge folding/Edge Trimming	WS_09						2.00
17	Storing the parts in the WIP Hangers	-						
18	Punching w/o HUD, LHD/RHD	PM_06						0.72
19	Transporting The Airducts CS W&W/O HUD, LHD/RHD	-						3.5
20	Weld the Airduct, Carrier CS and Chute with IR welding machine	IRW_07						1.42
21	Transport the Injected Carrier Lower CS, LHD/RHD	-						3.5
22	Weld the - carrier upper C&S, LHD/RHD & Lower with US welding machine	USW_08						1.175
23	Inspection of the part	KK_09						0.65

24	Storing the parts in the Final Assembly Hangers							
25	Assembly 1	FA_01						1.55
26	Assembly 2	FA_02						1.08
27	Camera Control + Check	FA_03						0.675
28	Storing the finished parts in the boxes	-						

40.03

Table 3: Process Diagram IP_PU

No	Description of activity	Workstation	Operation	Transport	Inspection	Delay	Storage	Time (Min)
1	Injecting The Carrier PU LHD/RHD with Airbag Netz	-						1.4
2	Transporting The Injected part to Au58x Zone	-						3.0
3	Flaming process on the carrier PU LHD/RHD	FM_10						1:27
4	Foaming Process on carrier PU w&w/o HUD, LHD/RHD	FOM_11						3.1
5	Foamed Parts stored in rack for curing	-						
6	Punching of the foamed IP parts	PM 12						1.7
7	Weakening by milling machine	MM 13						2.37
8	Transporting The Airducts PU W&W/O HUD, LHD/RHD	-						4.0
9	Weld the Airduct and Carrier PU with IR welding machine	IRW_13						1.56

10	Inspection of the part	KK_09						
11	Storing the parts in the Final Assembly Hangers	-						
11	Assembly 1	FA_01						1.55
12	Assembly 2	FA_02						1.08
13	Camera Control + Check	FA_03						0.675
14	Storing the finished parts in the boxes							
								21.7

By examining the Process Diagram, areas for improvement, such as excess inventory and unnecessary transportation, were identified.

4.3.3 Spaghetti Diagram

In order to better understand the physical movement of the product and the workers inside the shop floor, a spaghetti diagram was created. This method illustrates the actual path of materials or personnel, revealing inefficiencies that may not be easily observed in traditional flow diagrams.

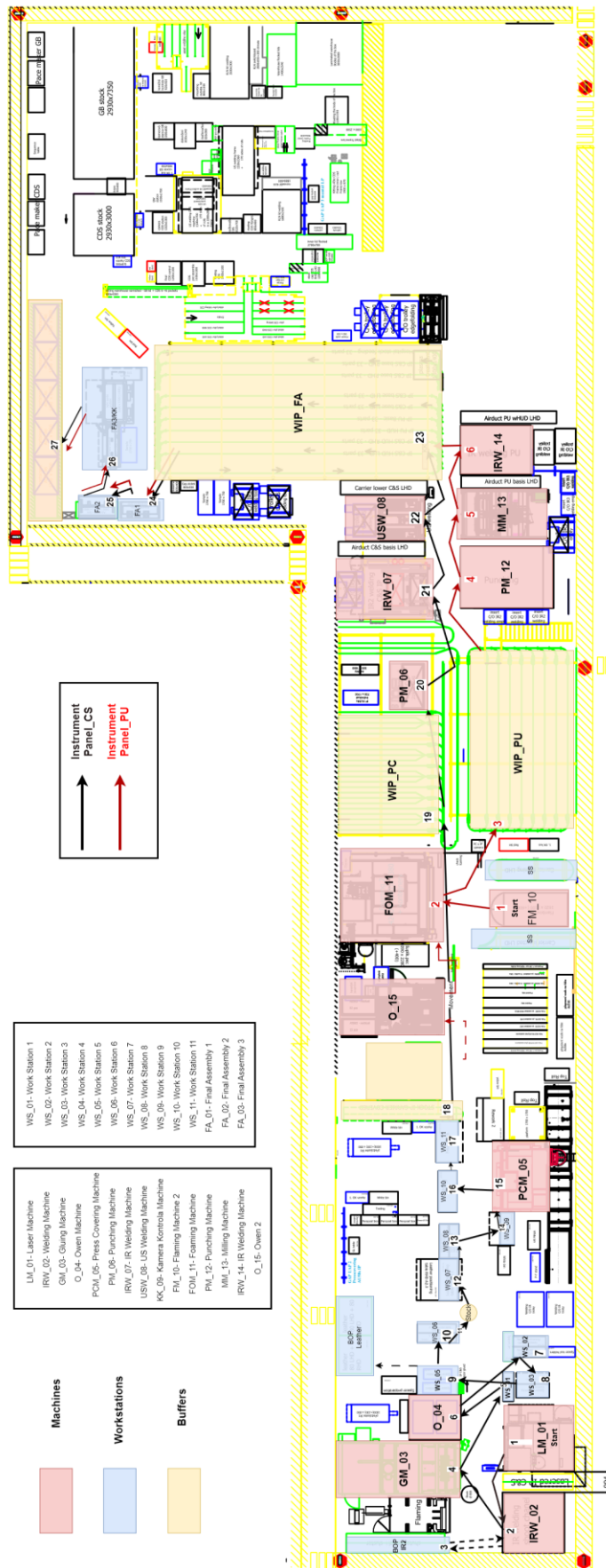

Figure 12 : Spaghetti Diagram (Current State)

Interpretation from Spaghetti Diagram:

The spaghetti diagram revealed several areas for improvement in the process flow. Here is a breakdown of the key findings:

- **Intersections:** Based on the Spaghetti Diagram, the workers' paths frequently crossed. This suggests potential delays and an increased risk of accidents.
- **Unnecessary Back and Forth Movement:** The diagram also indicates excessive backtracking by workers to retrieve materials or information. This signifies a potential issue with work allocation or material placement.
- **Insufficient Distance Between Workstations:** Workstations are positioned too close, hindering efficient movement, and potentially leading to safety concerns when the worker count is as of current state.

4.3.4 Value Stream Map

To gain a deeper understand how materials and information flow through the various process stages of the shop floor, a Value Stream Map (VSM) was created. This VSM proved to be a valuable tool, helping us identify inefficient practices and bottlenecks that would not have been apparent from a spaghetti diagram.

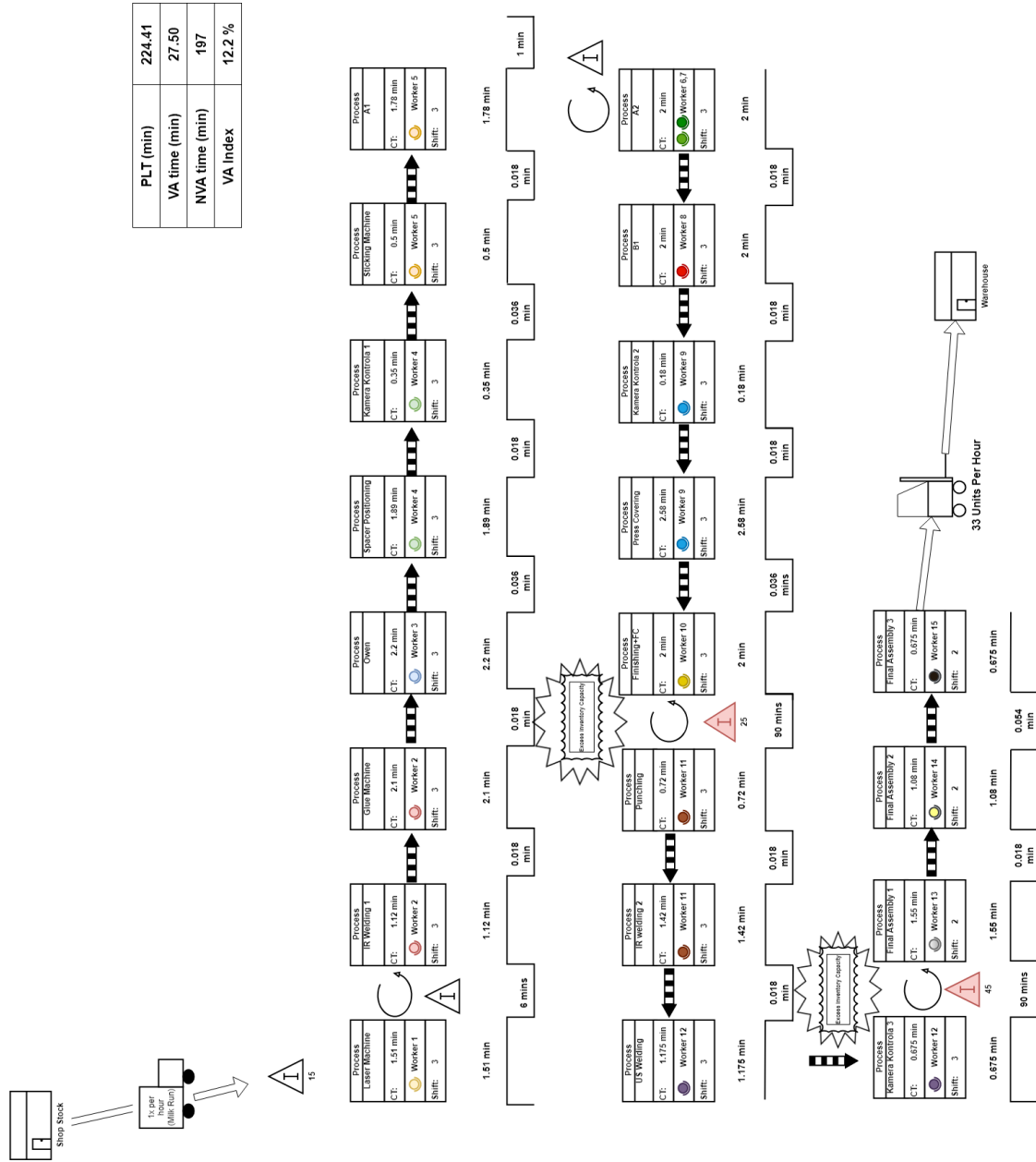

Figure 13: VSM (Current State-IP_CS) [source: own]

PLT (min)	203.52
VA time (min)	13.91
NVA time (min)	191
VA Index	6.8%

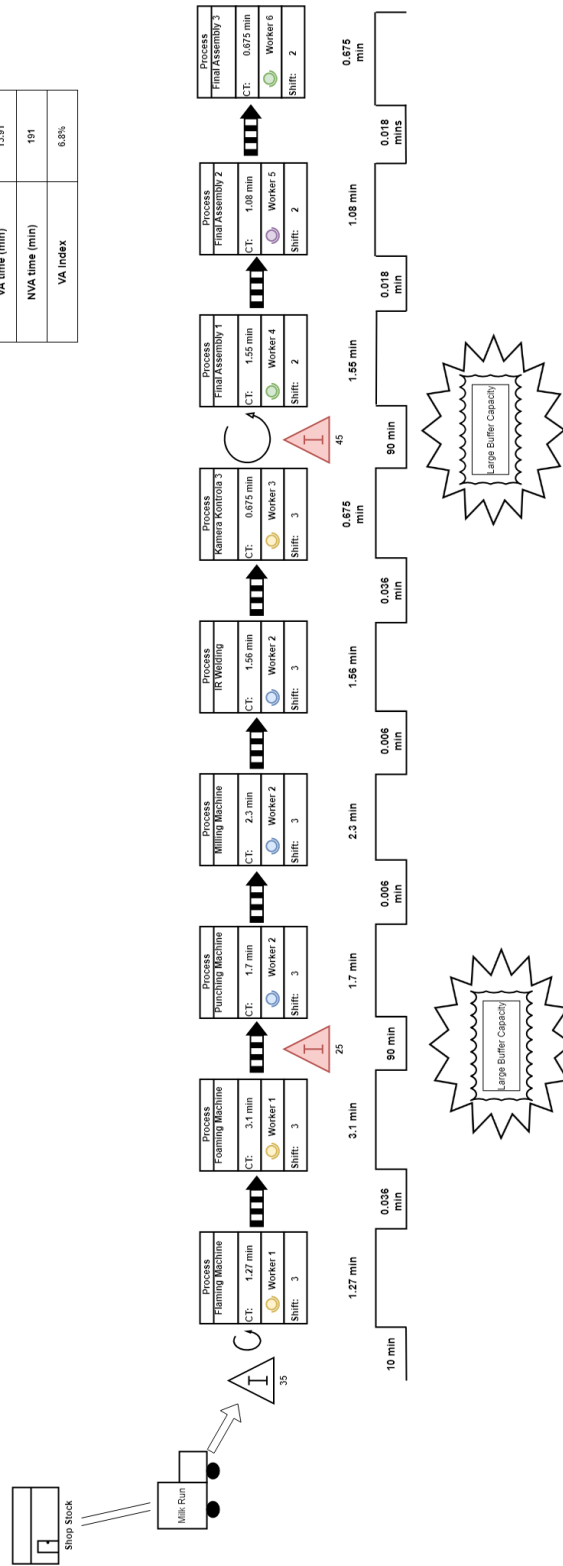

Figure 14:VSM (Current state-IP_PU) [source: own]

Interpretation from Value Stream Map:

The current state of VSM analysis revealed several opportunities for process optimization. These areas for improvement focus on reducing waste and improving overall efficiency.

- **Resource Optimization:** The VSM identified potential for reducing the number of workers required in the process. This could be achieved through streamlining tasks and line balancing.
- **Minimizing Non-Value-Added Activities:** The analysis highlighted opportunities for workers to reduce excessive walking. This could involve rearranging the physical layout of the workplace to bring materials and tools closer to where they are needed.
- **Inventory Reduction:** The VSM indicated the potential to decrease buffer inventory levels. This could be achieved by implementing a pull system, where production is triggered by actual customer demand rather than forecasts. Reducing inventory reduces associated costs and improves responsiveness.
- **Production Strategy:** The analysis suggests that implementing a pull production strategy could be beneficial. A pull system helps eliminate overproduction and ensures that only the necessary product is made at the right time.

4.3.5 Line Balancing

The Value Stream Mapping (VSM) analysis identified opportunities for improvement in worker utilization. Given the anticipated reduction in demand for parts, optimizing our labour force is crucial to ensure efficient resource allocation. Therefore, within the Analyze phase of the DMAIC cycle, we will conduct a worker line balancing analysis. This analysis will focus on the current shop floor situation, explicitly examining the tasks performed at each workstation and how workers are currently assigned.

		Takt Time	188.54	188.54	188.54	188.54	188.54	188.54	188.54	188.54
		Name	W1	W2	W3	W4	W5,W6	W7	W8	W9
Operator	CT	-	-	113.6	107.3	119.4	119.4			119.7
	Machine	Loading	9	21.5	20.5	10.5	-		16.5	-
		Automatic 1	80.6	103.1	127.5	10	-		119.5	-
		Unloading	9	13	10	10	-	-	7	-
		Automatic 2	-	-		-	-	-	-	-
		Walking	0.72	1.44	4.32	3.6	1.44	2.16	0.72	0.72

Figure 15: Worker Process Table (Press Covering)

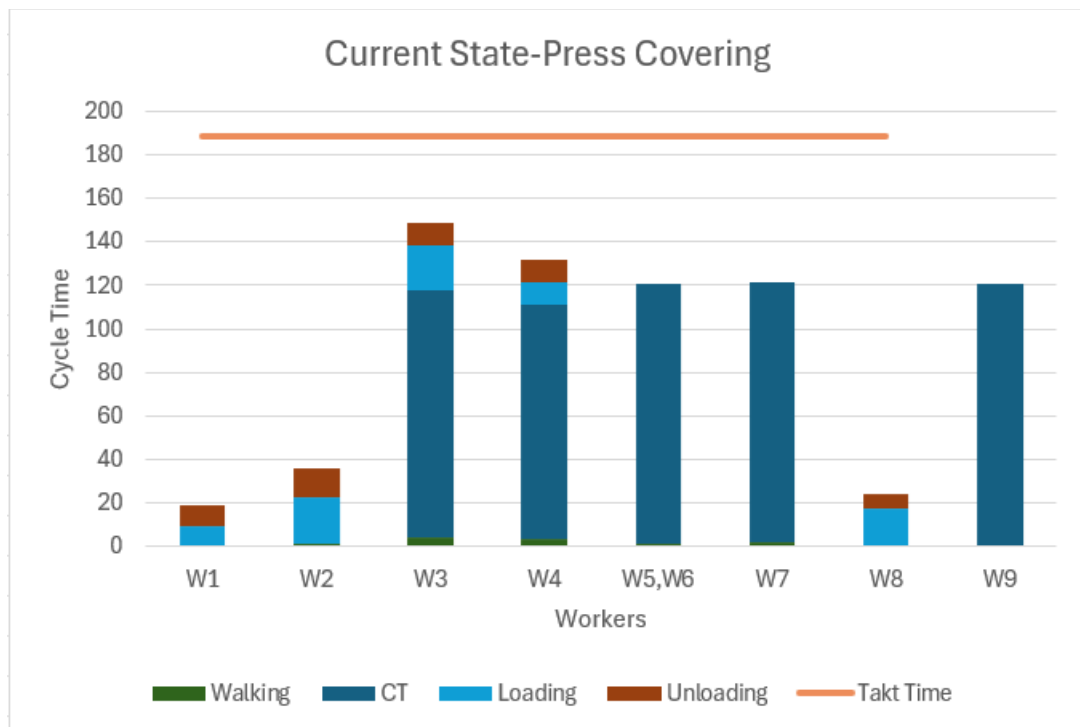

Figure 16: Worker Line Balancing-Press Covering (Current State)

Balancing Efficiency (Press Covering) = 43 %

		Takt Time	249.375	249.375
		Name	W1	W2
Operator	CT		-	-
	Loading		36.9	27.5
Machine	Automatic 1		146.2	82
	Unloading		61.1	5.1
	Walking		2.16	3.24

Figure 17: Worker Process Table (Welding-IP_CS)

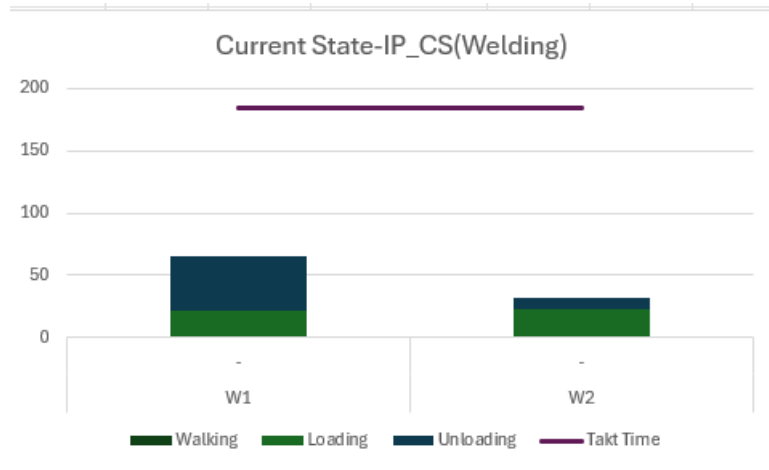

Figure 18: Worker Balancing Diagram (Welding-IP_CS)

		Takt Time	184.6	184.6
		Name	W1	W2
Operator	CT	-	-	-
	Machine	Loading	20.4	21.9
	Automatic 1	106.3	67.1	
	Unloading	43.8	8.6	
	Walking	0.72	1.44	

Figure 19: Worker Process Table (Welding-IP_PU)

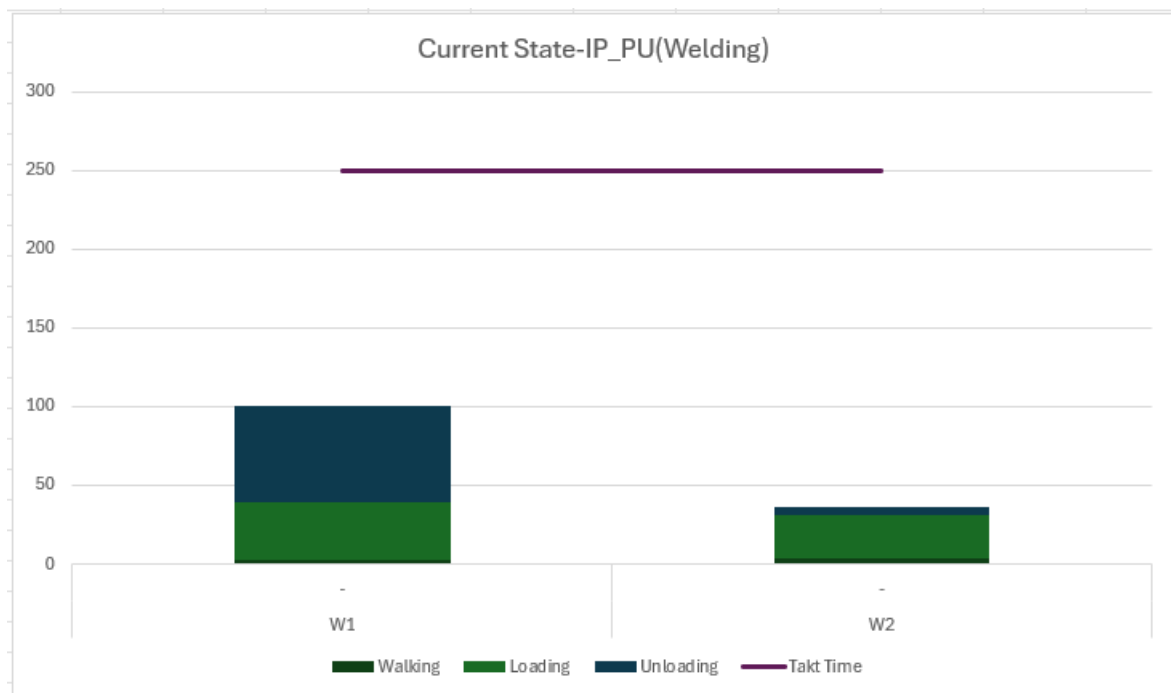

Figure 20: Worker Balancing Diagram (Welding-IP_PU)

Balancing Efficiency Welding (IP*CS) = **26%**

Balancing Efficiency Welding (IP*PU) = **27%**

Interpretation From Line Balancing:

- **Worker Optimization Identified:** The current state line balancing analysis revealed a concrete opportunity to optimize worker allocation.
- **Task Distribution Insights:** The analysis provided valuable insights into the tasks performed at each workstation and the current distribution of workload among workers.
- **Efficiency Improvement Potential:** By implementing a more balanced worker assignment, we can aim to improve overall production efficiency.

4.3.6 Simulation of the Current State

This section utilizes a virtual simulation environment to visualize the real-time behaviour of a Current model Audi AU58X IP production zone. The Lanner Witness 14 software was employed to facilitate this simulation process.

Part Detail:

- At first, the parts are placed in the simulation from the “designer element” tab and defined by double-clicking on them.
- The historical demand determines the inter-arrival time of parts. The rate is set to 15 parts per hour for Instrument Panel Cut Sew and 12 parts per hour for Instrument Panel PU.
- Then, the attributes for machines' processing time (T_{ac}) that are common for both the parts are specified by placing them in the simulation. Each machine has its own processing time attributes.

Detail Part - IP_CS

General Attributes Route Actions Costing Reporting Notes

Name:
IP_CS

Arrivals

Type:
Active

Maximum Arrivals:
Unlimited

First Arrival At:
0.0

Shift:
ShiftIP_PC_WE

Input to Model

Inter Arrival Time:
60.0

Lot Size:
15

To...

Push

Actions on Create... ✓

Exit From Model

Actions on Leave... ✕

OK Cancel Help

Figure 21:IP_CS Part Detail [source: own]

Detail Part - IP_PU

General Attributes Route Actions Costing Reporting Notes

Name:
IP_PU

Arrivals

Type:
Active

Maximum Arrivals:
Unlimited

First Arrival At:
0.0

Shift:
ShiftIP_PC_WE

Input to Model

Inter Arrival Time:
60.0

Lot Size:
12

To...

Push

Actions on Create... ✕

Exit From Model

Actions on Leave... ✕

OK Cancel Help

Figure 22:IP_PU Part Detail [source: own]

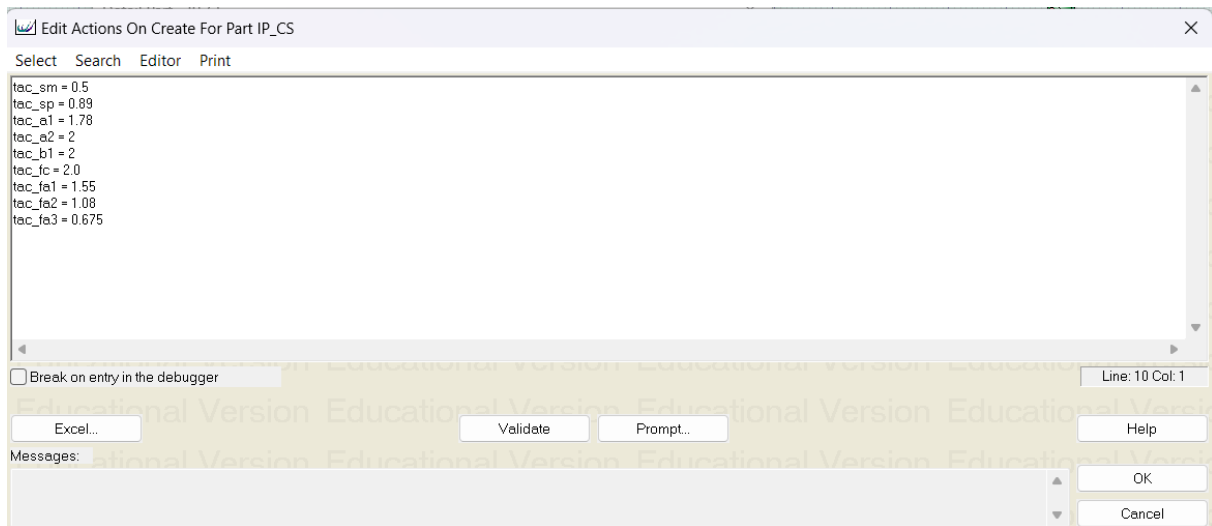

Figure 23: Actions on Crate IP_CS[source: own]

Machine Detail:

- The machine details are given by double-clicking on the machine icon, and the machine's name can be changed accordingly.
- The type of machine is specified as "Multiple Cycle" since it has multiple processes, including loading, automatic, and unloading.
- The cycle time is specified under the section "duration". The cycle time of Machines is determined by Stopwatch Study or Chronometry. Also, the cycle time of Workstations is defined before in the "actions on create" in part detailing.

Detail Machine - LM_01

General Setup Breakdowns Shift Actions Costing Reporting Notes

Name: LM_01 Quantity: 1 Priority: Lowest Type: Multiple Cycle

Inherit Attribute Values

	Cycle name	Input			Duration				Output				
		Quantity	From	Actions on Input	Actions on Start	Labor Rule	Cycle Time	Actions on Finish	Finish Quantity	Output Quantity	To	Actions on Output	Output From
1	Loading	1	Pull	N	N	Y	0.15	N	1	0	Wait	N	Front
2	Automatic	0	Wait	N	N	N	1.36	N	1	0	Wait	N	Front
3	Unloading	0	Wait	N	N	Y	0.15	N	1		Push	N	Front

Figure 24:Detail Machine [source: own]

Detail Machine - WS_01

General Setup Breakdowns Fluid Rules Shift Actions Costing Reporting Notes

Name: WS_01 Quantity: 1 Priority: Lowest Type: Single

Input

Quantity: 1

From...
Wait

Actions on Input... x

Duration

Cycle Time: tac_sp

Labor Rule... ✓

Actions on Start... x Actions on Finish... x

Output

Quantity: 1

To...
Wait

Actions on Output... x

Output From: Front

Figure 25:Detail Workstation [source: own]

Buffer Detail:

- The Buffer's details are given by double-clicking on the buffer icon, and the buffer's name can be changed accordingly.
- After each operation, parts are stored in buffers. Figures 24, 25, 26 and 27 illustrate the buffers used in the simulation.
- The Buffers Used in Simulation include:
 - Initial Buffer (Press Covering)
 - Initial Buffer (PU Variant)
 - WIP Hangers (Cut & Sew Variant)
 - WIP Hangers (PU Variant)
 - WIP Hangers (Final Assembly)
- The capacity of Buffers was identified by counting in real-time in the production zone.
- Delays in three buffers are done to study the part storage across shifts. This accounts for varying takt times between production sections, enabling analysis of buffer utilization and potential bottlenecks for optimization.

Detail Buffer - Initial

General Actions Costing Reporting Notes

Name: Initial Quantity: 1 Capacity: 60

Input Option: Rear

Delays Option: None

Output Option: First

Search from
 Rear
 Front

Actions on Input... X

Actions on Output... X

OK Cancel Help

Figure 26:Initial Buffer (IP_CS) [source: own]

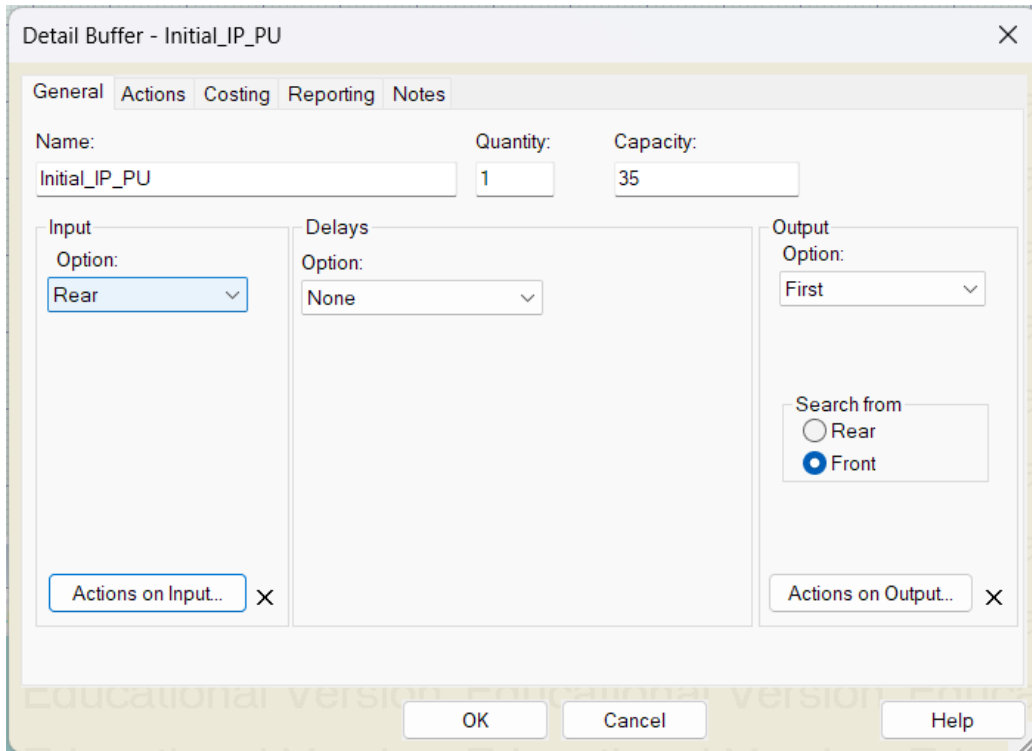

Figure 27:Initial Buffer IP_PU [source: own]

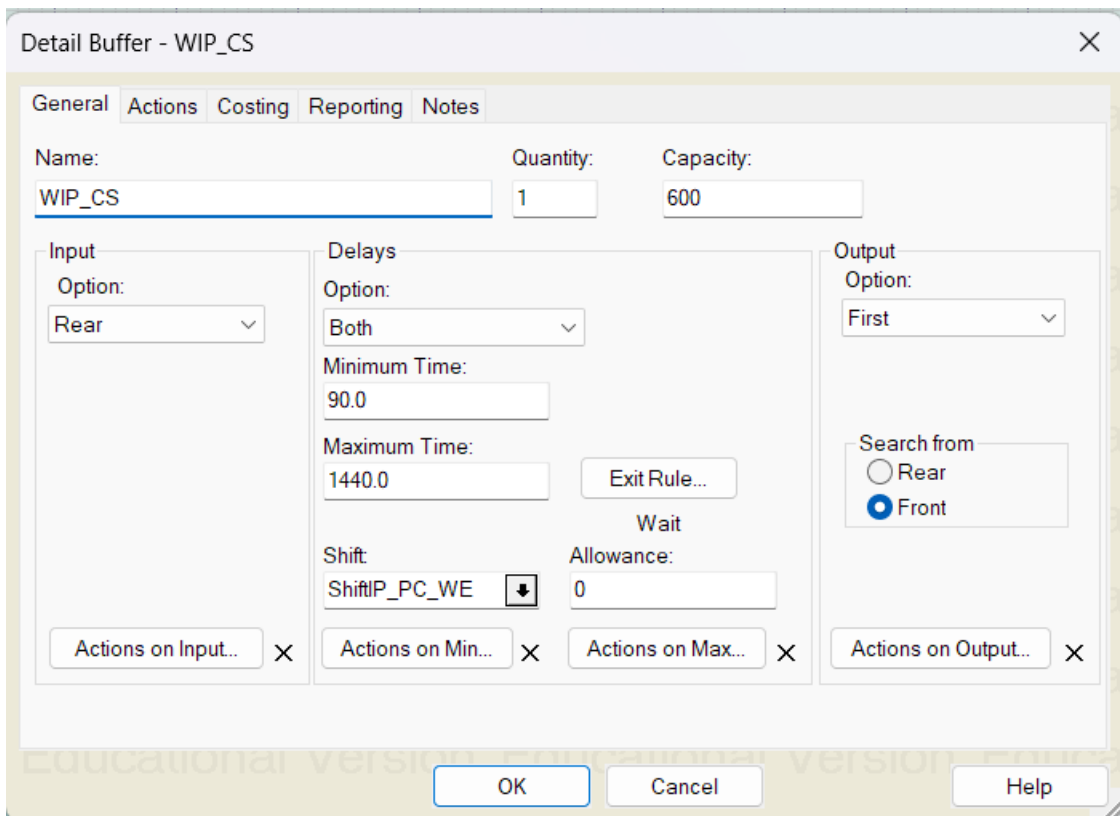

Figure 28:WIP_CS [source: own]

Detail Buffer - WIP_PU

General Actions Costing Reporting Notes

Name: WIP_PU Quantity: 1 Capacity: 200

Input Option: Rear

Delays Option: Both
 Minimum Time: 90.0
 Maximum Time: 1440.0
 Exit Rule...
 Wait
 Shift: ShiftP_PC_WE
 Allowance: 0

Output Option: First
 Search from: Rear Front

Actions on Input... Actions on Min... Actions on Max... Actions on Output...

OK Cancel Help

Figure 29:WIP_PU [source: own]

Detail Buffer - WIP_FA

General Actions Costing Reporting Notes

Name: WIP_FA Quantity: 1 Capacity: 405

Input Option: Rear

Delays Option: Both
 Minimum Time: 90.0
 Maximum Time: 1440.0
 Exit Rule...
 Wait
 Shift: ShiftP_PC_WE
 Allowance: 0

Output Option: First
 Search from: Rear Front

Actions on Input... Actions on Min... Actions on Max... Actions on Output...

OK Cancel Help

Figure 30:WIP_FA [source: own]

Shift Detail:

- The shifts are defined based on the worker's working hours, including break times. Three shift attributes are specified to assign shifts to the workers.
- The defined shift elements are then assigned to the machines under the “shift” tab on the machine detail window.

	Period Type	Working Time	Rest Time	Overtime	Sub Shift Name	Total
1	Period	450 0	30 0	0 0		480
2	Period	450 0	30 0	0 0		480
3	Period	450 0	30 0	0 0		480
Total		1350	90	0		1440

Figure 31:Shift_PC_WE [source: own]

	Period Type	Working Time	Rest Time	Overtime	Sub Shift Name	Total
1	Period	450 0	30 0	0 0		480
2	Period	450 0	30 0	0 0		480
Total		900	60	0		960

Figure 32:Shift FA [source: own]

After finishing all the above steps, we get the simulation model, as shown in the picture below.

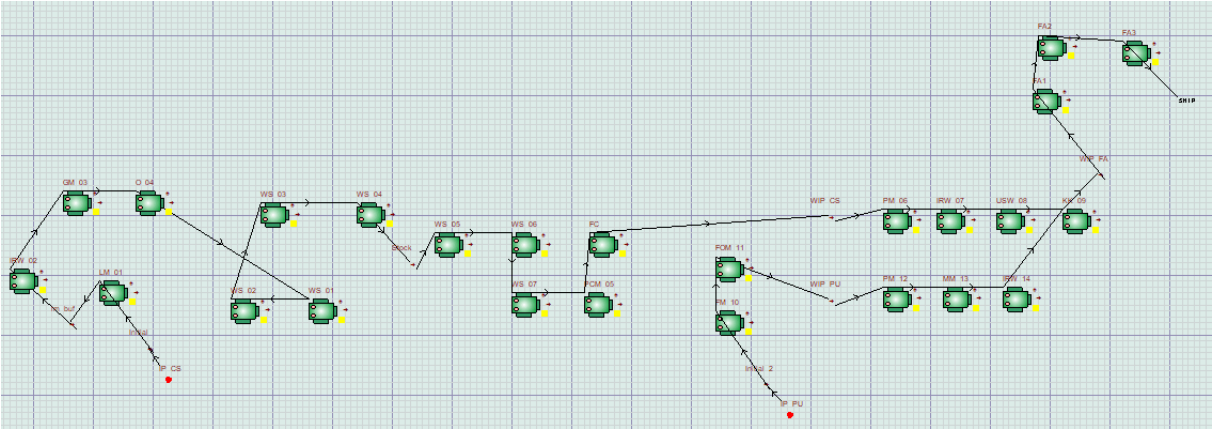

Figure 33:Simulation Current State [source: own]

Statistics:

The simulation is performed by setting the simulation period, in which we run the model for a 32*1440 period, where 32 is the number of days, and 1440 is the duration (24*60) placed in the simulation box. In the 32 days, two days will be the warmup period. Manufacturing simulations typically require a warmup period since our simulation is likely to begin empty (no products at any of the machines), so the warmup time is given to fill the whole system with parts. The model will then be simulated using the Run, Pause, and Stop buttons.

After the simulation, we collected the simulation model's statistics. We used several statistics, and the simulation results are shown below. These findings are gathered by clicking the element tree, selecting the entire model, and getting the statistics.

Part Statistics:

The current state's Part statistics confirms it meets customer demand with zero part rejections. Additionally, the simulation identified an average processing time for parts.

Name	No. Entered	No. Shipped	No. Scrapped	No. Assembled	No. Rejected	W.I.P.	Avg W.I.P.	Avg Time	Sigma Rating
IP_CS	10187	10125	0	0	0	62	56.45	224.41	6.00
IP_PU	8148	8100	0	0	0	48	41.02	203.92	6.00

Figure 34:Part Statistics (Current State) [source: own]

Machine Statistics:

Figure 35 provides statistics for each machine used in the production, including information of their idle, busy, and setup rates.

WITNESS
Machine Statistics Report by On Shift Time

Name	No. Of Opera	% Idle	% Busy	% Cycle Wait	% Filling	% Emptying	% Blocked	% Setup	% Setup Wait	% Broken Do	% Repair Wa
LM_01	10125	58.50	41.50	0.00	0.00	0.00	0.00	0.00	0.00	0.00	0.00
IRW_02	10125	36.88	32.75	2.09	0.00	0.00	28.29	0.00	0.00	0.00	0.00
GM_03	10125	34.00	66.00	0.00	0.00	0.00	0.00	0.00	0.00	0.00	0.00
O_04	10125	38.75	61.25	0.00	0.00	0.00	0.00	0.00	0.00	0.00	0.00
WS_01	10125	100.00	0.00	0.00	0.00	0.00	0.00	0.00	0.00	0.00	0.00
WS_02	10125	87.10	12.90	0.00	0.00	0.00	0.00	0.00	0.00	0.00	0.00
WS_03	10125	100.00	0.00	0.00	0.00	0.00	0.00	0.00	0.00	0.00	0.00
WS_04	10125	75.00	25.00	0.00	0.00	0.00	0.00	0.00	0.00	0.00	0.00
WS_05	10125	50.00	50.00	0.00	0.00	0.00	0.00	0.00	0.00	0.00	0.00
WS_06	10125	49.69	50.00	0.00	0.00	0.00	0.31	0.00	0.00	0.00	0.00
ws_07	10125	58.23	8.72	0.91	0.00	0.00	32.13	0.00	0.00	0.00	0.00
PCM_05	10125	29.25	70.75	0.00	0.00	0.00	0.00	0.00	0.00	0.00	0.00
FC	10125	50.00	50.00	0.00	0.00	0.00	0.00	0.00	0.00	0.00	0.00
PM_06	10125	67.50	32.50	0.00	0.00	0.00	0.00	0.00	0.00	0.00	0.00
IRW_07	10125	64.35	35.65	0.00	0.00	0.00	0.00	0.00	0.00	0.00	0.00
PM_12	8100	73.80	26.20	0.00	0.00	0.00	0.00	0.00	0.00	0.00	0.00
MM_13	8100	52.84	47.16	0.00	0.00	0.00	0.00	0.00	0.00	0.00	0.00
USW_08	10125	71.88	28.12	0.00	0.00	0.00	0.00	0.00	0.00	0.00	0.00
IRW_14	8100	63.69	31.30	0.00	0.00	0.00	5.01	0.00	0.00	0.00	0.00
KK_09	18225	74.43	22.44	3.13	0.00	0.00	0.00	0.00	0.00	0.00	0.00
FM_10	8100	47.23	18.06	0.00	0.00	0.00	34.71	0.00	0.00	0.00	0.00
FOM_11	8100	44.00	56.00	0.00	0.00	0.00	0.00	0.00	0.00	0.00	0.00
FA1	18225	63.33	25.00	0.00	0.00	0.00	11.67	0.00	0.00	0.00	0.00
FA2	18225	74.99	25.00	0.00	0.00	0.00	0.01	0.00	0.00	0.00	0.00
FA3	18225	100.00	0.00	0.00	0.00	0.00	0.00	0.00	0.00	0.00	0.00

Figure 35:Machine Statistics (Current State) [source: own]

Buffer Statistics:

These statistics show the total in and out for the parts, as shown in Figure 33. They also reveal how many parts were maximum stored in the buffer, which helps us identify the new inventory capacity of the buffers used in the simulation model.

WITNESS
Buffer Statistics Report by On Shift Time

Name	Total In	Total Out	Now In	Max	Min	Avg Size	Avg Time	Avg Delay C	Avg Delay TI	Min Time	Max Time
Initial	6089	6075	14	15	0	4.38	18.66			0.00	64.65
WIP_CS	6101	6075	26	26	19	22.50	89.62	0.00	0.00	90.00	120.00
WIP_PU	4874	4860	14	23	13	18.00	89.74	0.00	0.00	90.00	120.00
WIP_FA	10975	10935	40	45	36	40.55	89.79	0.05	0.12	90.00	120.47
Initial_2	4871	4860	11	12	0	2.94	15.63			0.00	58.90

Figure 36:Buffer Statistics [source: own]

Labor Statistics:

Labour statistics expose a critical area for improvement. A significant portion of the workforce experiences excessive idle time, indicating an imbalance in workload distribution. This inefficiency will be addressed in the future state by implementing worker line balancing techniques.

WITNESS									
Labor Statistics Report by On Shift Time									
Name	% Idle	% Busy	No. Of Jobs	No. Of Jobs	Avg Job Time	Quantity	No. Of Jobs Ended	No. Of Jobs	
Labor001	92.50	7.50	0	0	0.15	1	20250	20250	
Labor002	85.75	14.25	0	0	0.14	1	40500	40500	
Labor003	86.25	13.75	0	0	0.11	1	50625	50625	
Labor004	75.00	25.00	0	0	0.50	1	20295	20295	
Labor005	75.00	25.00	0	0	1.99	2	10170	10170	
Labor006	50.00	50.00	0	0	2.00	1	10125	10125	
Labor007	82.93	17.07	0	0	0.23	1	30375	30375	
Labor008	50.00	50.00	0	0	1.99	1	10170	10170	
Labor009	76.13	23.87	0	0	0.24	1	40545	40545	
Labor010	77.28	22.72	45	0	0.16	1	56745	56745	
Labor011	93.36	6.64	0	0	0.17	1	16200	16200	
Labor012	88.00	12.00	0	0	0.30	1	16200	16200	
Labor013	86.40	13.60	0	1	0.34	1	16245	16246	
Labor014	81.54	18.46	0	1	0.23	1	32445	32446	
Labor015	75.00	25.00	0	0	0.55	1	18270	18270	
Labor016	75.00	25.00	0	0	0.56	1	18225	18225	
Labor017	100.00	0.00	0	0	0.00	1	18225	18225	

Figure 37:Labor Statistics [source: own]

Shift Statistics:

This gives us information on the utilization rate per shift. % On-shift is the utilized time on the shift, and % Off-shift is break time and non-working time.

WITNESS			
Shift Statistics Report by On Shift Time			
Name	% On-Shift	% Off-Shift	Completed Shifts
ShiftIP_PC_W	93.75	6.25	18
Shift_FA	93.75	6.25	27

Figure 38:Shift Statistics

Interpretation from Simulation Statistics:

The Witness simulation provided valuable insights into the current performance of the production layout. By analysing the model's output, opportunities for improvement were identified in two key areas: **Buffer** and **labour** utilization. These findings align perfectly with the primary objective of layout optimization – to create space and reduce resource allocation.

- **Buffer and WIP Reduction:**

- The simulation revealed the potential for reducing the capacity in work-in-process (WIP) and final assembly hangers. This presents a significant opportunity to free up valuable floor space. Given the drastic decline in demand, decreasing WIP inventory is feasible and strategically sound. By streamlining buffer capacities, we can optimize material flow and potentially reduce lead times.
- So, the statistics allowed us to identify the maximum number of parts that were in the buffer during the simulation run period.

WIP_CS=26

WIP_PU=23

WIP_FA=45

- These values, plus the consideration of safety stock, will be the buffers' new capacity in the improved simulation model.

- **Labor Optimization:**

The simulation further indicated areas where we could potentially reduce resource allocation, specifically by reducing the number of workers. This aligns with minimizing resource expenditure considering the reduced demand of the parts. The new improvised Labor Assignment Will be done based on the Worker Balancing Diagram.

4.3.7 KPI Measurement for Current State

Production Lead Time (PLT): The measured value in the current state is **224.1 minutes** for **IP_CS** and **203.92** minutes for **IP_PU**, indicating the total lead time for production.

Number of Workers: The measured value in the current state is **17**, indicating the total workforce involved in the production process.

Products Travelling Distance (PD): The measured value in the current state is **48 meters**, representing the total distance travelled by-products as they move through the production process based on the layout and spaghetti diagram.

Production Area: Currently, the production area measures **956.25 square meters**, showing how much space is available for manufacturing.

Table 4: KPI Measurement (Current State)

KPI Code	KPI	Criteria Abbreviation	Measurement	Measured Value (Current State)
101	Production lead time	PLT	Simulation	IP_CS=224.1 mins IP_PU= 203.92 mins
102	Production Area	PA	Based on Layout	956.25 m ²
103	No of Workers	workers	No of workers in the Production area and workstations	17
104	Products Travelling distance	PTD	Layout diagram and Spaghetti diagram	48 metres

4.4 Improve

After thoroughly analysing the current state, we have identified areas to improve and made strategic changes to increase efficiency. We have also closely examined key performance indicators (KPIs) to evaluate the effectiveness of these changes.

This section will outline the layout improvements that have been implemented and will also provide insights into the corresponding KPI analysis. This will demonstrate how the shop floor is more efficient and effective than the current state.

4.4.1 Spaghetti Diagram(Optimized)

The initial spaghetti diagram analysis revealed inefficiencies in the current shop floor layout. Workers engaged in excessive back-and-forth movement for material procurement, creating bottlenecks at intersecting points. Additionally, underutilized space presented an opportunity for optimization.

To address these concerns, a redesigned layout was developed based on the spaghetti diagram insights. This optimized layout aimed to:

- **Minimize worker travel:** By strategically placing workstations and storage areas closer to frequently used materials, the redesigned layout minimizes the need for workers to backtrack and reduces overall travel distances.
- **Improve flow:** The layout optimizes the flow of materials by minimizing intersections and creating a U flow. This reduces congestion and bottlenecks, promoting smoother and more efficient material movement throughout the shop floor.
- **Utilize space effectively:** The redesign incorporates warehousing space within the shop floor. This eliminates the need for separate storage areas and maximizes the utilization of available space.

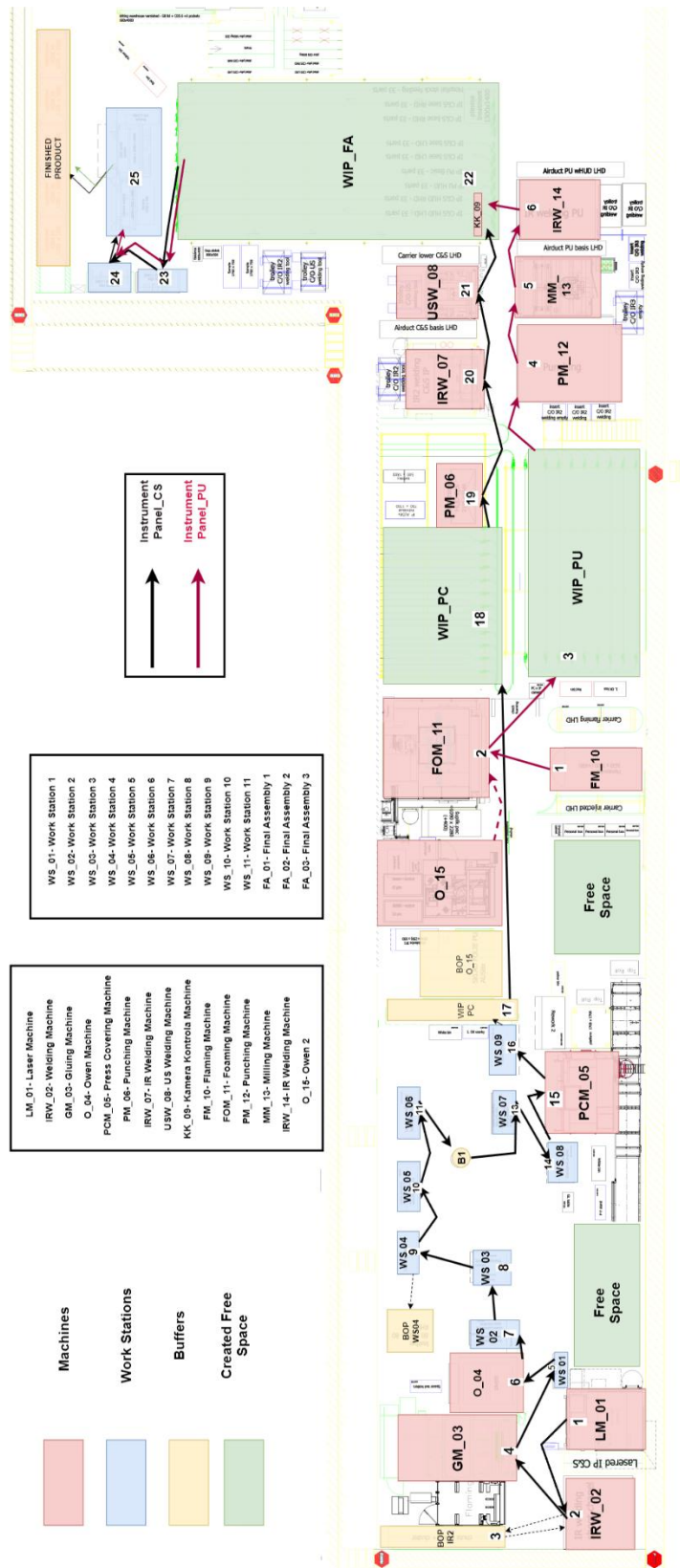

Figure 39: Optimized Spaghetti Diagram [source: own]

4.4.2 Spaghetti Diagram(Ideal)

The spaghetti diagram analysis reveals an ideal scenario – a one-piece flow layout. This layout is characterized by:

- **Minimal Intersections:** Workers and materials navigate the shop floor without crossing paths. This eliminates congestion points and ensures smooth, uninterrupted movement.
- **Reduced Product Travel Distance:** The layout minimizes the distance products travel between processing steps. This translates to less time spent on transportation and more time dedicated to value-adding activities.

These characteristics, as depicted in the ideal spaghetti diagram (Figure 38), signify a streamlined production process.

The minimized travel distances and efficient flow potentially lead to:

- **Lower Production Costs:** Reduced material handling and worker movement translate to lower operational costs.
- **Enhanced Workflow Efficiency:** The optimized layout fosters a smooth and efficient flow, allowing for faster production cycles and improved overall productivity.

The effectiveness of the chosen design is evident in its ability to minimize unnecessary product movement and promote a one-piece flow, ultimately leading to a more efficient production.

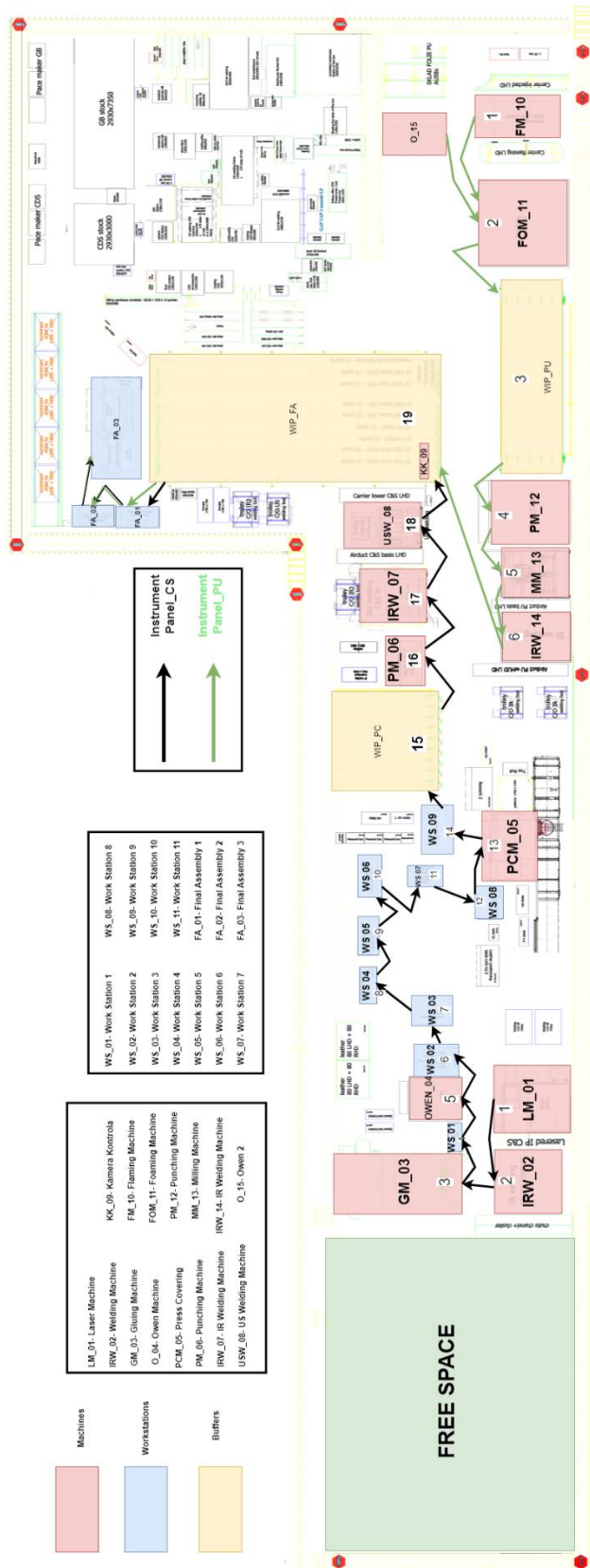

Figure 40: Ideal Layout [source: own]

4.4.3 Value Stream Map (Optimized)

Building upon the current state map, this section depicts the optimized value stream with value-added activities clearly identified and non-value-added elements minimized.

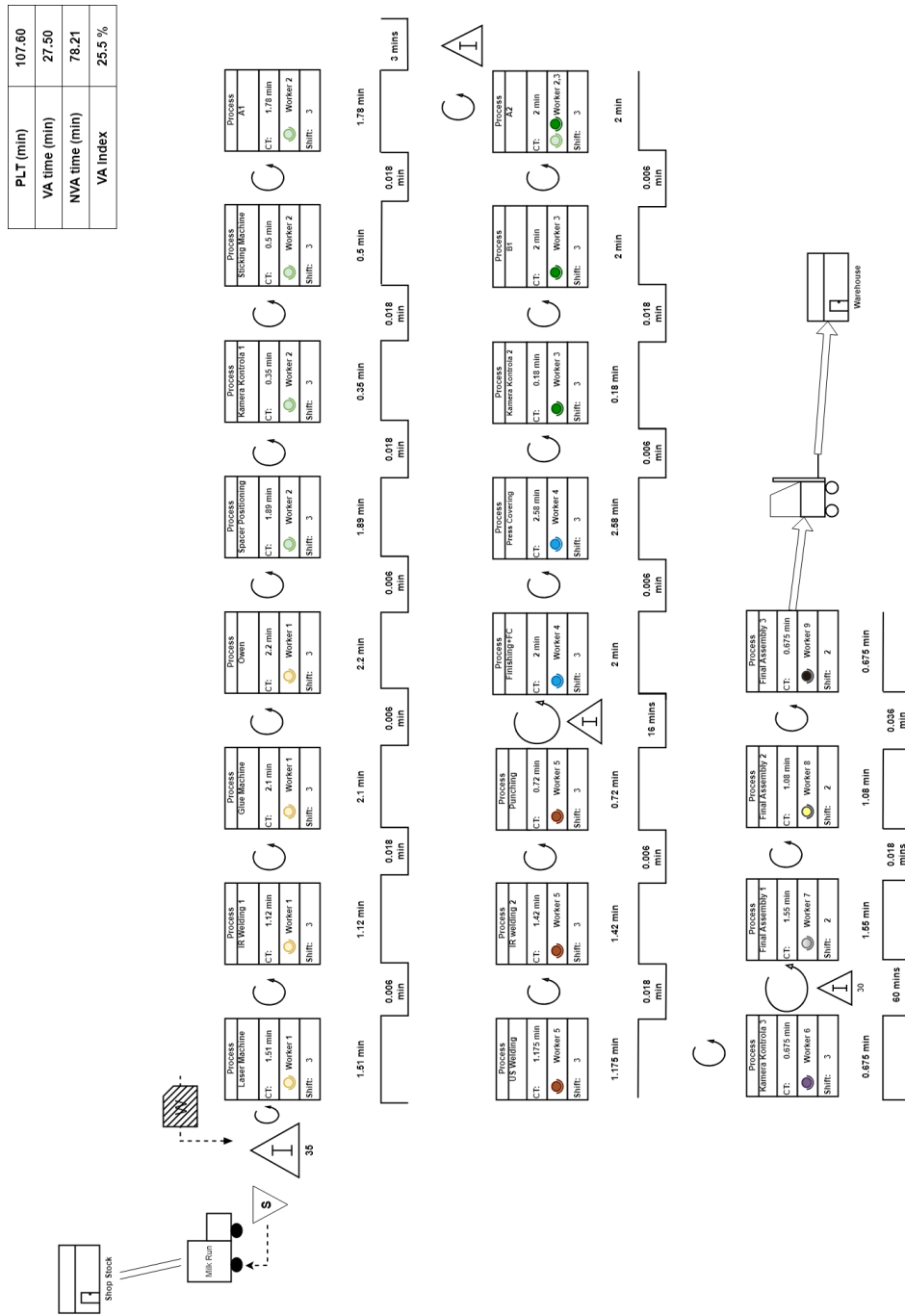

Figure 41:VSM (Optimized-IP_CS) [source: own]

PLT (min)	86.98
VA time (min)	13.91
NVA time (min)	73.07
VA Index	15.99 %

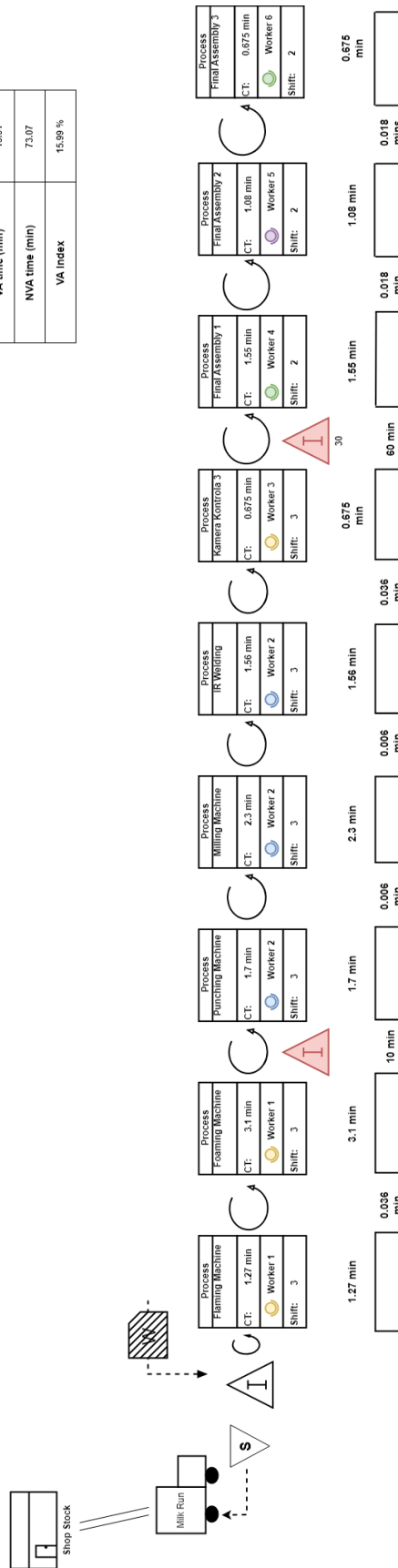

Figure 42: VSM (Optimized-IP_PU)
[source: own]

The initial analysis of the current state revealed inefficiencies such as a high number of workers, large buffers leading to excess inventory, and excessive walking resulting in non-value added (NVA) time. Additionally, the production strategy relied on a push system, potentially leading to overproduction, and wasted resources.

To address these issues, a Kanban implementation strategy was developed and integrated into the optimized Value Stream Map (VSM). This strategy focuses on transitioning to a pull-based system driven by actual customer demand, with the core objective of optimizing production line efficiency.

By implementing this Pull system, the optimized VSM aims to achieve several key benefits:

- **Reduced WIP Capacity:** By only producing and moving parts when there is demand, the overall WIP throughout the production line is minimized, minimizing storage requirements, and freeing up valuable floor space. The WIP Hangers Capacity levels are adjusted based on the simulation results of the current State.

Buffers	Initial	Optimized
WIP_CS	600	50
WIP_PU	200	50
WIP_FA	405	100

Figure 43:WIP Hanger Capacity [source: own]

- **Improved Efficiency:** Pulling parts only when needed makes the production flow smoother, potentially reducing Production lead times (time to complete a product) and increasing overall throughput.

Production Lead Time		Initial	Optimized
	IP_CS	224.41 mins	107.6 mins
IP_PU	203.92 mins	86.98 mins	

Figure 44:Production Lead Time Comparison [source: own]

- **Flexibility:** Kanban allows for adjustments to production up or down based on changes in demand. This agility allows the production line to adapt to market fluctuations more effectively.

- **Optimized Workforce:** Due to the drastic decrease in demand and the streamlining of processes through Kanban, the number of workers required for production has also been reduced. This allows for optimized resource allocation, potentially leading to cost savings and improved efficiency.

	Initial	Optimized
Worker Count	17 workers	12 workers

Figure 45: Workforce Comparison [source: own]

4.4.4 Value Stream Map (Ideal)

In this ideal state value stream map, we envision a perfect scenario, eliminating all waste and delays to achieve maximum efficiency.

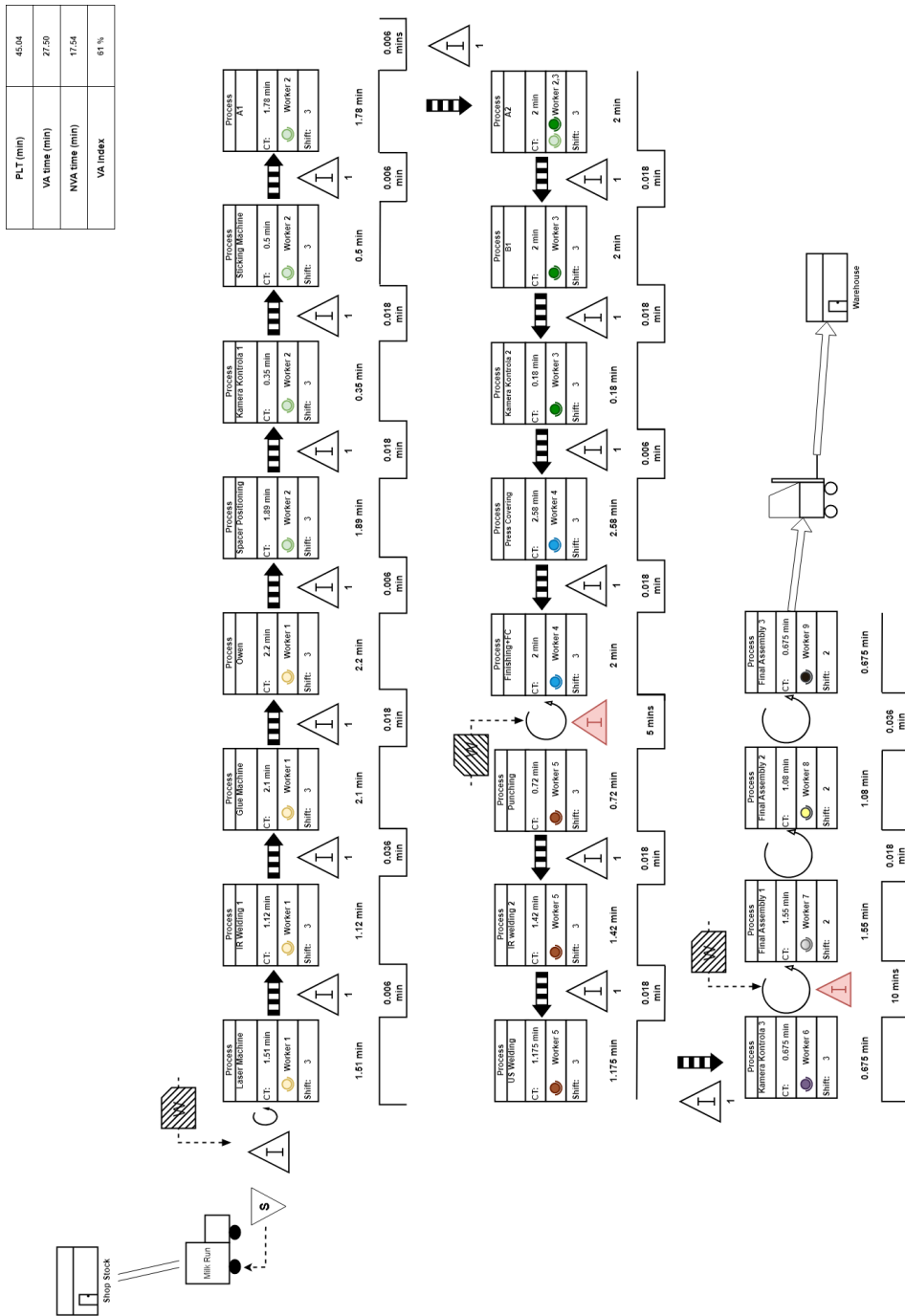

Figure 46:VSM (Ideal-IP_CS) [source: own]

PLT (min)	25.98
VA time (min)	13.91
NVA time (min)	17.54
VA Index	54 %

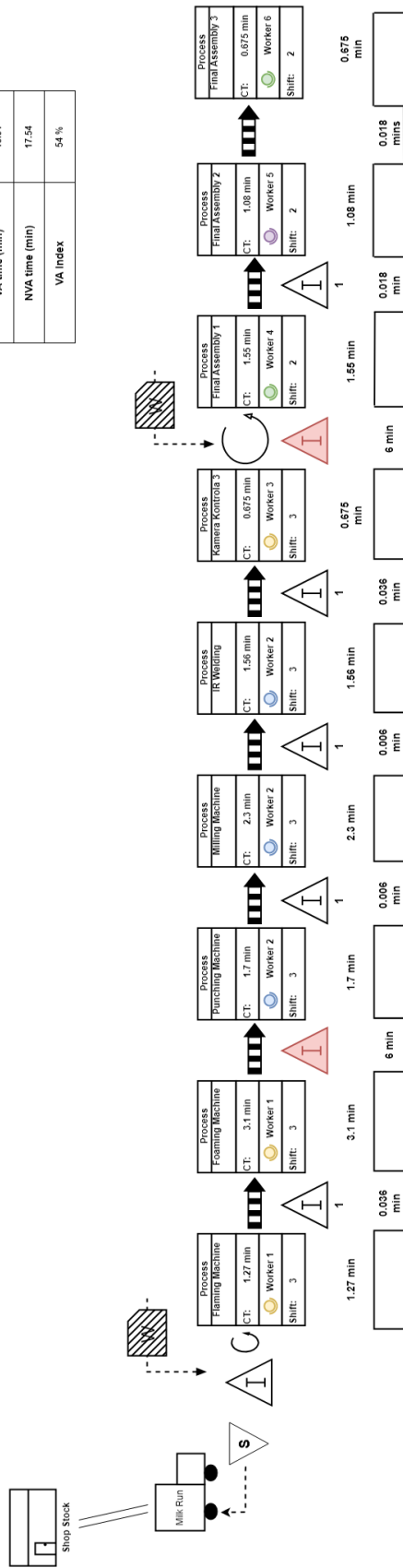

Figure 47:VSM (Ideal-IP_PU) [source: own]

The ideal state value stream map (VSM) represents the goal of production efficiency – a **One-piece flow** layout. This ensures that production is aligned closely with customer demand, minimizing waste and inefficiencies.

By implementing this One-Piece flow system, the ideal VSM aims to achieve several key benefits:

- **Enhanced Flexibility:** One-piece flow makes production more responsive to changes in customer demand. Production can be easily adjusted by adding or removing workers from the line, allowing for quicker adaptation to market fluctuations.
- **Improved Quality:** With each part being processed individually, defects are easier to identify and isolate. This allows for quicker corrective actions and reduces the risk of producing a whole batch of defective parts.
- **Reduced Lead Time:** One-piece flow eliminates delays, leading to a faster time for a product to move through the production process. This translates to a shorter lead time for fulfilling customer orders.

		Initial	Optimized	Ideal
Production Lead Time	IP_CS	224.41 mins	107.6 mins	45.04 mins
	IP_PU	203.92 mins	86.98 mins	25.98 mins

Figure 48: PLT Comparison (Ideal) [source: own]

4.4.5 Line Balancing

The initial line balancing analysis identified an uneven distribution of workload among workers. While no individual worker's tasks exceeded the takt time, some workers had a significantly higher workload than others. This imbalance would negatively impact efficiency, especially with anticipated reduced demand.

To address this, worker line balancing is done. This involves redistributing tasks among workers to achieve a more consistent workload across the unit. This optimization ensures that even with a smaller workforce (due to reduced demand), each worker remains productively utilized throughout their shift.

		Takt Time	188.54	188.54	188.54	188.54	188.54
		Name	W1	W2	W3	W4	W5
Operator	CT			113.6	178.4	167	119.7
	Machine	Loading	40.5	21			16.5
		Automatic 1	311.2	20			119.5
		Unloading	32	21			7
		Automatic 2					
		Walking	2.88	4.68	2.16	2.16	3.24

Figure 49: Worker Process Table (Press Covering-Improved State)
[source: own]

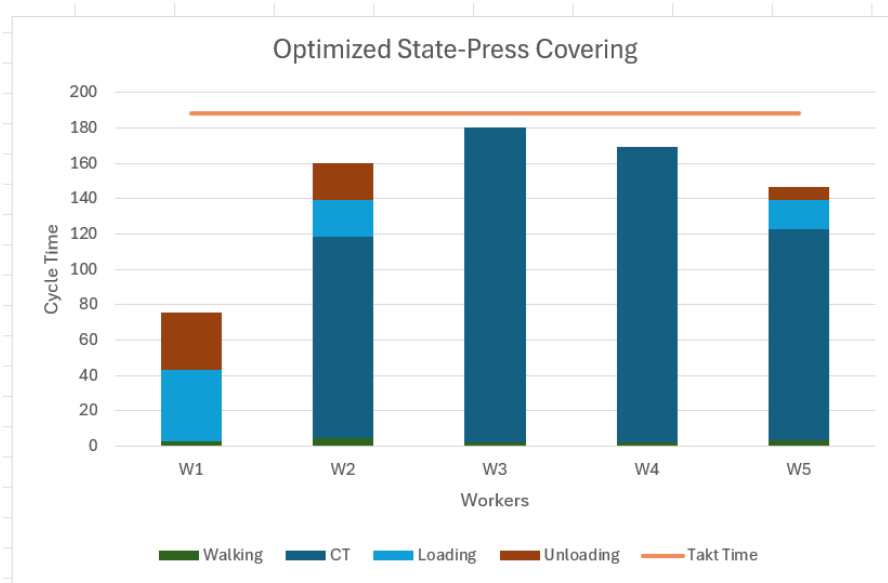

Figure 50: Worker Line Balancing-Press Covering (Improved State) [source: own]

Initial analysis identified uneven workload among press covering workers. Worker rebalancing reduced the workforce from 9 to 5 in the rebalanced diagram, ensuring efficient resource allocation even with reduced demand. This optimizes labour costs and maintains production output, and it also increases the **Balancing efficiency of Press Covering to 75%**

		Takt Time	184.6
		Name	W1
Operator	CT	-	
	Loading	42.3	
Machine	Automatic 1	173.4	
	Unloading	52.4	
	Walking	2.16	

Figure 51: Worker Process Table -Welding-IP_CS (Improved State) [source: own]

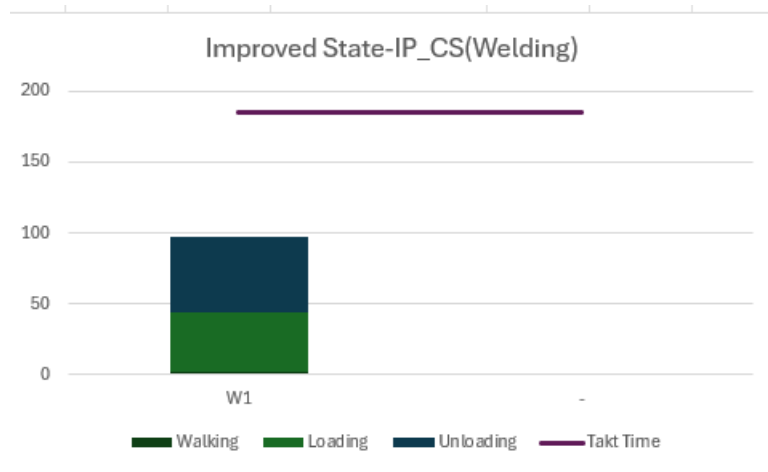

Figure 52: Worker Line Balancing-Welding-IP_CS (Improved State) [source: own]

		Takt Time	249.375
		Name	W1
Operator	CT		-
	Loading		64.4
Machine	Automatic 1		228.2
	Unloading		66.2
	Walking		5.4

Figure 53: Worker Process Table-Welding-IP_PU (Improved State) [source: own]

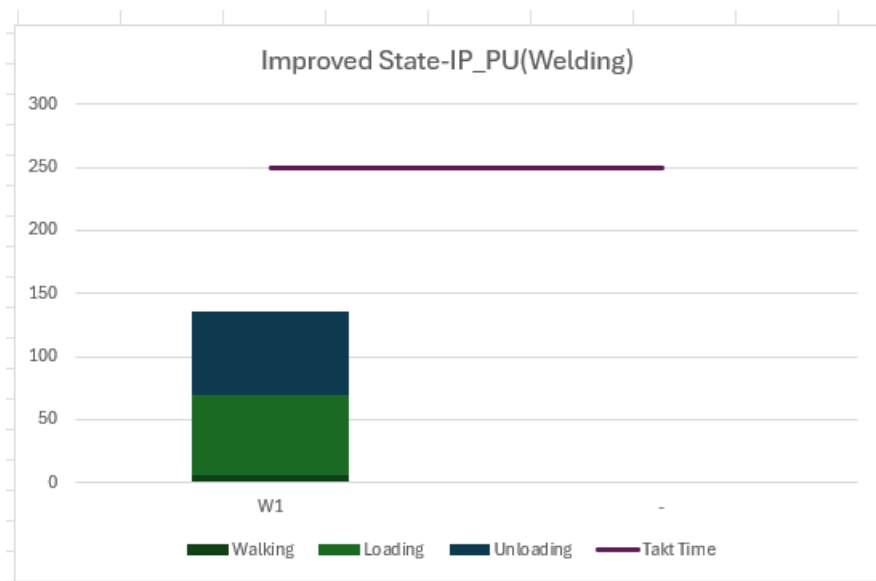

Figure 54: Worker Line Balancing-Welding-IP_PU (Improved State) [source: own]

Analysis identified **very low workload** for workers in welding section. Worker rebalancing streamlined the process, requiring only **1 worker** in the rebalanced diagram. Also the Balancing Efficiency of Welding Section is improved too.

Balancing Efficiency Welding (IP*CS) = **52%**

Balancing Efficiency Welding (IP*PU) = **55%**

4.4.6 Simulation of the Future State

This subsection details the simulation process employed to evaluate and optimize the performance of the production zone. The initial simulation served as a baseline to identify areas for improvement.

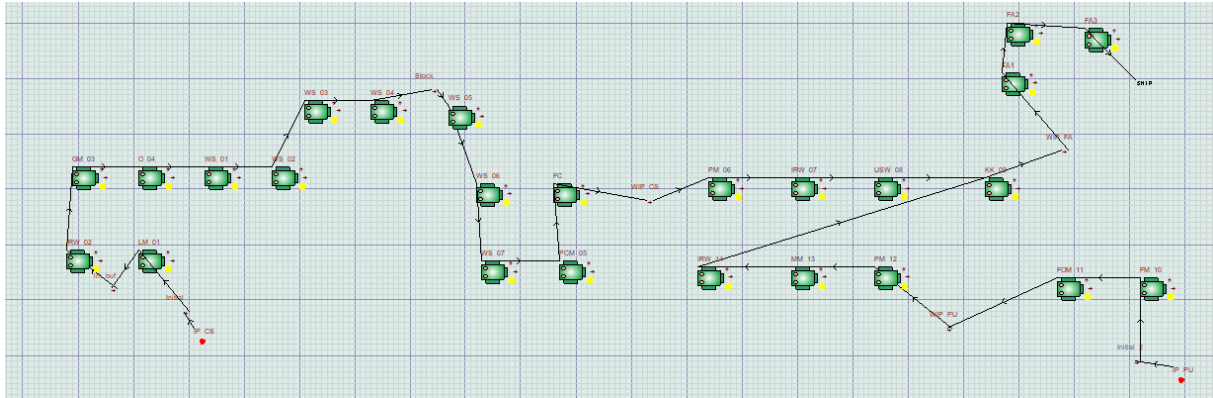

Figure 55: New Simulation

General	Actions	Costing	Reporting	Notes
Name:	Quantity:	Capacity:		
WIP_CS	1	50		
Input Option:	Delays Option:	Output Option:		
Rear	Both	First		
	Minimum Time:		Search from	
	90.0		<input type="radio"/> Rear	
	Maximum Time:		<input checked="" type="radio"/> Front	
	1440.0			
	Exit Rule...			
	Wait			
	Shift	Allowance:		
	ShiftIP_PC_WE	0		
Actions on Input...	Actions on Min...	Actions on Max...	Actions on Output...	
OK	Cancel	Help		

Figure 56: Revised Buffer (WIP_CS)

Detail Buffer - WIP_PU

General Actions Costing Reporting Notes

Name: WIP_PU Quantity: 1 Capacity: 50

Input Option: Rear

Delays Option: Both

Minimum Time: 90.0

Maximum Time: 1440.0 Exit Rule...

Wait Allowance: 0

Shift: ShiftP_PC_WE

Output Option: First

Search from: Rear Front

Actions on Input... Actions on Min... Actions on Max... Actions on Output...

OK Cancel Help

Figure 57: Revised Buffer (WIP_PU)

Detail Buffer - WIP_FA

General Actions Costing Reporting Notes

Name: WIP_FA Quantity: 1 Capacity: 100

Input Option: Rear

Delays Option: Both

Minimum Time: 90.0

Maximum Time: 1440.0 Exit Rule...

Wait Allowance: 0

Shift: ShiftP_PC_WE

Output Option: First

Search from: Rear Front

Actions on Input... Actions on Min... Actions on Max... Actions on Output...

OK Cancel Help

Figure 58: Revised Buffer (WIP_FA)

Initial State Simulation and Bottleneck Identification:

- The initial state simulation mirrored the current operational setup of the production zone. Statistical data from this simulation revealed bottlenecks within the system, specifically regarding **Buffer** size and **Labour** allocation.

Buffer Optimization:

Analysis of the initial buffer statistics focused on identifying the maximum number of parts typically stored within each buffer. To account for potential fluctuations, a safety stock buffer was added to this maximum value. This revised buffer capacity was then implemented in the optimized simulation. The key finding was that throughput remained consistent with demand despite the decreased buffer capacity, indicating a successful optimization of this factor.

Buffers	Initial	Optimized
WIP_CS	600	50
WIP_PU	200	50
WIP_FA	405	100

Figure 59: Buffer Capacities Comparison

WITNESS
Buffer Statistics Report by On Shift Time

Name	Total In	Total Out	Now In	Max	Min	Avg Size	Avg Time	Avg Delay C	Avg Delay Ti	Min Time	Max Time
Initial	303	303	0	15	0	2.78	11.92			0.00	24.30
WIP_FA	522	486	36	52	18	38.38	88.97	1.15	2.86	90.00	179.82
WIP_CS	284	264	20	32	19	20.22	86.15	0.57	2.61	90.00	179.73
Im_buf	307	275	32	33	0	12.86	54.46			0.00	215.87
WIP_PU	262	240	22	23	13	18.02	83.21	0.00	0.00	90.00	176.30
Stock	275	265	10	10	2	9.51	44.98			8.11	131.35
Initial_2	244	244	0	12	0	2.54	13.51			0.00	28.90

Figure 60: New Buffer Statistics

Labor Allocation Optimization:

Analysis of the initial state simulation revealed a critical opportunity for improvement in labour utilization. Statistics from the current state simulation showed that most of the workforce experienced more idle time than busy time. This, coupled with the anticipated decrease in demand for parts (based on internal data), necessitated a strategic approach to labour allocation.

The optimized simulation revised the labour allocation approach to address this inefficiency. The workforce size was adjusted by analysing the initial labour statistics and considering the expected decrease in demand. However, it is crucial to note that this optimization did not compromise throughput. The optimized simulation statistics revealed that **demand for parts was still met effectively** despite the reduced workforce, signifying a successful improvement in labour utilization. Figure 49 depicts the new statistics of the balanced workforce in the shopfloor.

WITNESS
Labor Statistics Report by On Shift Time

Name	Labor001	Labor002	Labor003	Labor004	Labor005	Labor006	Labor007	Labor008	Labor009	Labor010	Labor011
% Busy	22.73	70.10	87.30	53.09	17.51	15.24	18.79	39.53	20.74	20.74	7.35
% Idle	77.27	29.90	12.70	46.91	82.49	84.76	81.21	60.47	79.26	79.26	92.65
Avg Job Time	0.14	0.63	2.00	0.81	0.27	0.18	0.23	0.33	0.52	0.52	0.18
Quantity	1	1	1	1	2	1	1	1	1	1	1
No. Of Jobs N	1	1	1	1	1	0	1	0	0	0	0
No. Of Jobs P	0	0	0	0	0	0	0	0	0	0	0
No. Of Jobs S	1982	1361	531	794	1586	1008	977	1440	486	486	486
No. Of Jobs E	1981	1360	530	793	1585	1008	976	1440	486	486	486

Figure 61:New Labour Statistics

Table 5: Comparison Simulation

Parameter	Initial Simulation	Improved Simulation	Change
Buffer 1 (WIP_PC)	600 units	50 units	-550 units
Buffer 2 (WIP_PU)	200 units	50 units	-150 units
Buffer 3 (WIP_FA)	400 units	100 units	-300 units
Number of Workers	17	12	Reduced by 5

4.4.7 KPI Measurement of Improved and Ideal State

Production Lead Time (PLT): The Production Lead Time (PLT) for the improved and ideal layout has been significantly optimized, 107.6 minutes for IP_CS and 86.98 minutes for IP_PU in the Optimized version and 45.04 minutes for IP_CS and 25.98 minutes for IP_PU in the ideal state.

Number of Workers: The measured value in the improved and ideal state is 12, indicating the total workforce involved in the production process.

Products Travelling Distance (PD): The newer layout has shown a reduction in traveling distance, measuring 40 meters, and the ideal layout's product traveling distance is 25 meters.

Production Area (PA): The production area for the optimized layout is the same as the current state, which is 956.25 m². For The ideal state, it is 743.35 m².

Table 6: KPI Measurement Optimized and Ideal State

KPI Code	KPI	Criteria Abbreviation	Measurement	Measured Value (Optimized State)	Measured Value (Ideal State)
101	Production lead time	PLT	Value Stream Mapping	IP_CS=107.6 mins IP_PU= 86.98 mins	IP_CS=45 mins IP_PU=25.98 mins
102	Production Area	PA	Based on Layout	956.25 m ²	743.35 m ²
103	No of Workers	workers	No of workers in the Production area and workstations, Witness Simulation	12	12
104	Products Travelling distance	PTD	Layout diagram and Spaghetti diagram	40 metres	25 metres

4.5 Multicriteria Analysis

A multicriteria analysis was conducted to determine the best layout out of three options.

First, a KPI matrix was created to display the KPI values recorded for all three layouts. These values will serve as a baseline for further processing in the multicriteria analysis.

Table 7: KPI matrix

KPI Monitored	PLT (IP_CS)	PLT (IP_PU)	PA (m ²)	No of Workers	Product Travelling Distance (metres)
Layout 1 (Current State)	224.41	203.92	956.25	17	48
Layout 2 (Improved State)	107.6	86.98	956.25	12	40
Layout 3 (Ideal State)	45.04	25.98	743.5	12	25

Table 8:KPI Improvement Summary for Different Layouts

KPI	Layout 1 to Layout 2 Improvement (%)	Layout 1 to Layout 3 Improvement (%)
PLT (IP_CS)	52.05%	79.93%
PLT (IP_PU)	57.36%	87.25%
PA (m ²)	0%	22.24%
Number of Workers	29.41%	29.41%
Product Travelling Distance (m)	16.67%	47.92%

The maxima minima (min-max) normalization approach in multi-criteria decision-making (MCDM) is used to create the normalized matrix to facilitate an unbiased comparison of alternatives with diverse performance indicators (KPIs). This method depends on classifying KPIs as either beneficial or non-beneficial.

- **Beneficial KPIs** represent criteria where higher values are preferable (e.g., profit, production output).
- **Non-beneficial KPIs:** These represent criteria where lower values are desired (e.g., cost, defect rate, number of workers).

In our specific case, all selected KPIs (PLT, PA, number of workers, product travel distance) are aimed at minimizing and categorizing them as non-beneficial.

The matrix is created by finding the lowest value for each KPI and then dividing all other values for that KPI by this minimum value.

For Example, the scores in PTD column are calculated by finding the lowest value for PTD which is 25 in the ideal state. Then we divide this 25 by the values of all the state.

Layout 1 (Current State)- $25/48=0.10$

Layout 2 (Optimized State)- $25/40=0.13$

Layout 3 (Ideal State)- $25/25=1$

Table 9: Normalized Matrix

KPI	L1	L2	L3
PLT(IP_CS)	0.20	0.42	1
PLT(IP_PU)	0.13	0.30	1
PA	0.78	0.78	1
No of Workers	0.71	1.00	1
PTD	0.52	0.63	1

Then, weightage or scores were assigned to each criterion through group decision-making, and these values were used to create a weighted decision matrix.

Table 10: Weighted decision matrix

Weightage or Score	KPI	L1	L2	L3
20%	PLT(IP_CS)	0.04	0.08	0.2
20%	PLT(IP_PU)	0.03	0.06	0.2
20%	PA	0.16	0.16	0.2
20%	No of Workers	0.14	0.20	0.2
20%	PTD	0.10	0.13	0.2
		0.43	0.54	1

Analysing this weighted matrix revealed **Layout 3 (Ideal Layout)** as the most optimal choice compared to the other two layouts.

4.6 Control

In the Control phase of the DMAIC framework, the focus shifts from implementation to ensuring that the improvements made are sustained over time. This phase is crucial for integrating changes into the organizational culture and processes, thereby solidifying the gains achieved during the improvement phase.

1.) A Pull Production System:

One key strategy proposed to optimize the shopfloor is the adoption of a pull strategy, such as the Kanban system. This system makes the production process demand-driven, ensuring that materials are only restocked or produced when needed. By implementing Kanban, the shopfloor can minimize waste associated with overproduction and excessive inventory while also facilitating a smoother flow of materials and reducing congestion.

2.) Multi-Skilling for Workforce Flexibility:

- Track worker **utilization rates** across different machines and stations to identify opportunities for workload balancing.
- Develop **cross-training programs** to equip workers with the skills to operate multiple machines or handle tasks at different workstations. This allows for more efficient deployment of the reduced workforce.
- Conduct periodic **skills assessments** to ensure workers maintain competency across their assigned skills. This ensures the effectiveness of the reduced resource allocation strategy.

3.) 5S Implementation:

- Implement the 5S methodology (Sort, Straighten, Shine, Standardize, Sustain) to maintain a clean, organized, and efficient work environment.
- Conduct regular 5S audits to ensure adherence to established procedures and identify areas for improvement.
- Integrate 5S principles into daily routines to foster a culture of continuous improvement.

4.) Continuous Improvement Culture:

Beyond implementing specific strategies and methodologies, fostering a culture of continuous improvement is crucial for sustained success. Encouraging employee involvement in problem-solving, providing opportunities for skill development and empowerment, and fostering open communication channels are essential components of this culture. Here are some ways to integrate continuous improvement into the production.

Encouraging Employee Participation:

- **Suggestion Mechanisms:** Implement suggestion boxes or online platforms to allow employees to submit ideas for further improvement. This fosters a sense of ownership and encourages problem-solving in the workforce.
- **Regular Feedback Sessions:** Conduct periodic meetings where employees can share their experiences and propose optimization strategies. These sessions can be a valuable source of insights and can help identify areas for further improvement.

Recognition and Visibility:

- **Recognition Programs:** Recognize and reward employees who actively participate in improvement initiatives. This public acknowledgment motivates continued participation and reinforces the value of a continuous improvement culture.
- **Visual Tracking Boards:** Implement visual tracking boards to display key metrics and celebrate achievements, keeping improvement efforts visible and motivating employees. These boards provide a clear picture of progress and can inspire further optimization efforts.

5 Economical comparison.

5.1 Labour Savings

The proposed layout change aims to optimize worker movement and collaboration, potentially reducing the required workforce. Currently, the production zone operates with 17 workers. The new layout design is complete, resulting in a reduction to **11** workers.

The average labour cost in the Czech Republic is about **120 CZK**. The minimum possible salary was set by the government of the Czech Republic and published in the collection of laws. Investment costs are strictly confidential. For this thesis work, I adjusted the actual investment cost. Therefore, the ROI can be calculated.

- 5 workers * 145 CZK/worker = 725 CZK/Day
- **260 Workdays (excluding weekends):**
Annual savings: 725 CZK/day * 260 days = 188,500 CZK

5.2 Relocation Cost of Machinery

The layout change necessitates the relocation of machinery within the production zone.

The actual cost of relocation will vary depending on factors like the number and complexity of machines, distance moved, and services required from the moving company.

For the purpose of this analysis, I will assume a relocation cost of: **CZK 500,000**

5.3 Return of Investment

$$\text{Return Of Investment} = \left(\frac{\text{Gains}}{\text{Investment Cost}} \right) * 100\% \quad (1)$$

Gains = 188,500 CZK

Investment Cost = 500,000 CZK

$$\text{ROI} = (188,500 \text{ CZK} / 500,000 \text{ CZK}) * 100$$

The economic analysis reveals a promising return on investment (ROI) of **37.7%** within the first year of implementing the proposed layout change. This indicates that the cost savings generated through reduced labour needs (17 workers to 12 workers) can potentially recoup the relocation costs of machinery (estimated at CZK 500,000) within a relatively short timeframe.

6 Conclusion

The primary objective of this thesis was to optimize the shop floor layout of the Audi Au58x production zone at Faurecia Interior Systems in response to a gradual decrease in production capacity as production phases out. In the theoretical section, we explored lean tools and production control strategies that would later inform the practical aspects of the thesis.

During the analysis phase, the production portfolio was established to outline the products manufactured within the zone. This was both described in text and illustrated with images. Following this, a detailed process diagram was created to analyze the production steps and measure the cycle time of each machine and workstation. A spaghetti diagram was then used to visually map the material flow for both products across the shop floor. Furthermore, a Value Stream Map (VSM) of the current state was conducted to identify inefficiencies and bottlenecks. Additionally, line balancing was performed to assess the current allocation of workloads among workers.

The opportunities identified during the analysis were addressed in the improvement phase by developing two new layouts. The first layout focused on optimizing part flow and creating valuable free space on the shop floor. The second, termed the ideal layout, proposed a U-shaped manufacturing cell and a one-piece flow system, significantly increasing space efficiency.

A multi-criteria Analysis was conducted to select the best layout among the three options, with the ideal layout emerging as the preferred choice. This layout met the company's objectives, such as creating additional space for warehousing by reducing the production area from **956.25 m² to 743.5 m²** and reducing the workforce from **17 to 12**, which is critical given the reduced demand.

Finally, using Lanner Witness 14 simulation software, current and future models were constructed with data from the company. The simulation results confirmed that the futuristic layout is feasible from both capacity and technological standpoints.

7 References

- [1] BAUDIN, Michel a Jonathan BARD. A Review of: “Lean Logistics: The Nuts and Bolts of Delivering Materials and Goods”. *Iie Transactions* [online]. 2006, 38, 797–798. Dostupné z: doi:[10.1080/07408170600684165](https://doi.org/10.1080/07408170600684165)
- [2] ZU, Xingxing, Lawrence D. FREDENDALL a Thomas J. DOUGLAS. The Evolving Theory of Quality Management: The Role of Six Sigma. *Journal of Operations Management* [online]. 2008. Dostupné z: doi:[10.1016/j.jom.2008.02.001](https://doi.org/10.1016/j.jom.2008.02.001)
- [3] HENSLEY, Rhonda L. a Kathryn DOBIE. Assessing readiness for six sigma in a service setting. *Managing Service Quality: An International Journal* [online]. 2005, 15(1), 82–101. ISSN 0960-4529. Dostupné z: doi:[10.1108/09604520510575281](https://doi.org/10.1108/09604520510575281)
- [4] HAKIMI, Saeid, Seyed M. ZAHRAEE a Jafri M. ROHANI. Application of Six Sigma DMAIC Methodology in Plain Yogurt Production Process. *International Journal of Lean Six Sigma* [online]. 2018. Dostupné z: doi:[10.1108/ijlss-11-2016-0069](https://doi.org/10.1108/ijlss-11-2016-0069)
- [5] Logistics (*Selected Chapters from Manufacturing Logistics*) [online]. 2024 [vid. 2024-05-03]. ISBN 978-80-7494-384-3. Dostupné z: <https://etul.publi.cz/en/book/547-logistics-selected-chapters-from-manufacturing-logistics>
- [6] TIMWOOD | 7 Verschwendungsarten | Hier Informieren! [online]. 25. leden 2021 [vid. 2024-05-03]. Dostupné z: <https://alphadi.de/timwood/>
- [7] ALTING, Leo. *Manufacturing Engineering Processes, Second Edition* [online]. 2. vyd. Boca Raton: CRC Press, 2020. ISBN 978-1-00-306717-7. Dostupné z: doi:[10.1201/9781003067177](https://doi.org/10.1201/9781003067177)
- [8] *The-blowing-operations-sequence-chart.png* (850×628) [online]. [vid. 2024-05-04]. Dostupné z: <https://www.researchgate.net/profile/Md-Shahriar-20/publication/359846369/figure/fig3/AS:11431281108249272@1671447952942/The-blowing-operations-sequence-chart.png>
- [9] SENDERSKÁ, Katarína, Albert MAREŠ a Štefan VÁCLAV. Spaghetti diagram application for workers’ movement analysis. 2017, 79, 139–150.
- [10] SCHULTE, Christof. *Logistika*. Praha: Victoria Publishing, 1994. ISBN 80-85605-87-2.
- [11] JOHNSTON, Robert, James ZHANG, Peter WALLIS a Richard JONES. Reasoning about Activity: Robots, Kanbans and the Intelligent Infrastructure. 2003.
- [12] SPEARMAN, Mark L., David L. WOODRUFF a Wallace J. HOPP. CONWIP: a pull alternative to kanban. *International Journal of Production Research* [online]. 1990, 28(5), 879–894. ISSN 0020-7543, 1366-588X. Dostupné z: doi:[10.1080/00207549008942761](https://doi.org/10.1080/00207549008942761)
- [13] KOBLASA, František. Multicriteria analysis. In: Technická univerzita v Liberci.
- [14] ROY, Bernard. Decision-Aid and Decision-Making. In: Carlos A. BANA E COSTA, ed. *Readings in Multiple Criteria Decision Aid* [online]. Berlin, Heidelberg: Springer, 1990, s. 17–35. ISBN 978-3-642-75935-2. Dostupné z: doi:[10.1007/978-3-642-75935-2_2](https://doi.org/10.1007/978-3-642-75935-2_2)

- [15] TOMPKINS, Jim, John A. WHITE, Yavuz A. BOZER a James A. TOMPKINS. *Facilities planning*. 4th edition. Hoboken, NJ: Wiley, 2010. ISBN 978-0-470-44404-7.
- [16] *Introduction to Simulation Software - GoldSim* [online]. [vid. 2024-05-04]. Dostupné z: <https://www.goldsim.com/Web/Introduction/#SimulationTypes>
- [17] SARIFUDIN, M. S., M. A. MANSOR a W. SAFIEI. Waste Simplification for Warehouse Using Boolean Logic. *International Journal of Engineering Technology and Sciences* [online]. 2018, 5(1), 44–52. ISSN 2462-1269. Dostupné z: doi:[10.15282/ijets.v5i1.2822](https://doi.org/10.15282/ijets.v5i1.2822)
- [18] TREBUŇA, Peter, Miriam PEKARČÍKOVÁ a Milan EDL. Digital Value Stream Mapping Using the Tecnomatix Plant Simulation Software. *International Journal of Simulation Modelling* [online]. 2019. Dostupné z: doi:[10.2507/ijsimm18\(1\)455](https://doi.org/10.2507/ijsimm18(1)455)
- [19] ISO TC 184/SC 5 N 1143. *Manufacturing operations management — Key performance indicators — Part 2: Definitions and descriptions of KPIs*. 31. srpen 2011
- [20] Value-StreamMapping.png (988×641) [online]. [vid. 2024-05-04]. Dostupné z: <https://tallyfy.com/wp-content/uploads/Value-StreamMapping.png>
- [21] KOBLASA, František. WORK - Measurement - Analysis - Standardisation. B.m.: TUL. 2022
- [22] GANORKAR, Ashwin Bhimrao, Ramesh R. LAKHE a Kamalkishor N. AGRAWAL. Methodology for application of Maynard Operation Sequence Technique (MOST) for time-driven activity-based costing (TDABC). *International Journal of Productivity and Performance Management* [online]. 2019, 68(1), 2–25. ISSN 1741-0401. Dostupné z: doi:[10.1108/IJPPM-06-2017-0156](https://doi.org/10.1108/IJPPM-06-2017-0156)
- [23] FIS Plazy [online]. [vid. 2024-05-19]. Dostupné z: <https://lh3.googleusercontent.com/p/AF1QipPsktX7vFCeN6DaDqkr3KwoqoK4d1kXtArMQzeb=s680-w680-h510>
- [24] Instrument Panel [online]. [vid. 2024-05-08]. Dostupné z: <https://www.energysavinginjectionmoldingmachine.com/index.php?productId=11512898&r=Products/Detail>
- [25] Glovebox [online]. [vid. 2024-05-08]. Dostupné z: <https://www.sjplasticworld.com/uploads/202134701/injection-tool-glove-box39327361704.jpg>
- [26] Cover Driver Side [online]. [vid. 2024-05-08]. Dostupné z: https://m.media-amazon.com/images/I/71JF+V0SKdL._AC_UF894,1000_QL80_DpWeblab_.jpg
- [27] Line Balancing Diagram [online]. [vid. 2024-05-19]. Dostupné z: <https://www.isixsigma.com/wp-content/uploads/2018/11/cycletimetakttime-400x206.png>

Attachment

- A.1 Spaghetti Diagram (Current State)**
- A.2 Spaghetti Diagram (Optimized State)**
- A.3 Spaghetti Diagram (Ideal State)**

Attachment 1: Spaghetti Diagram (Current State)

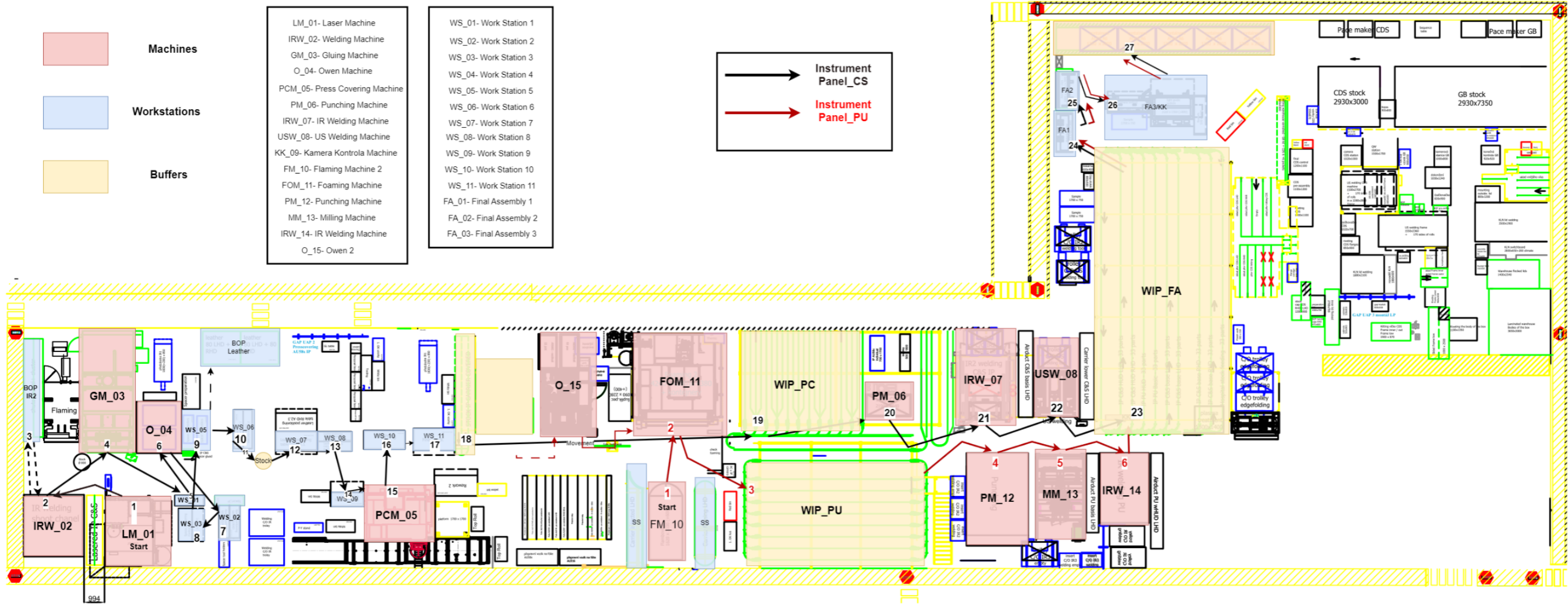

Attachment 2: Spaghetti Diagram (Optimized State)

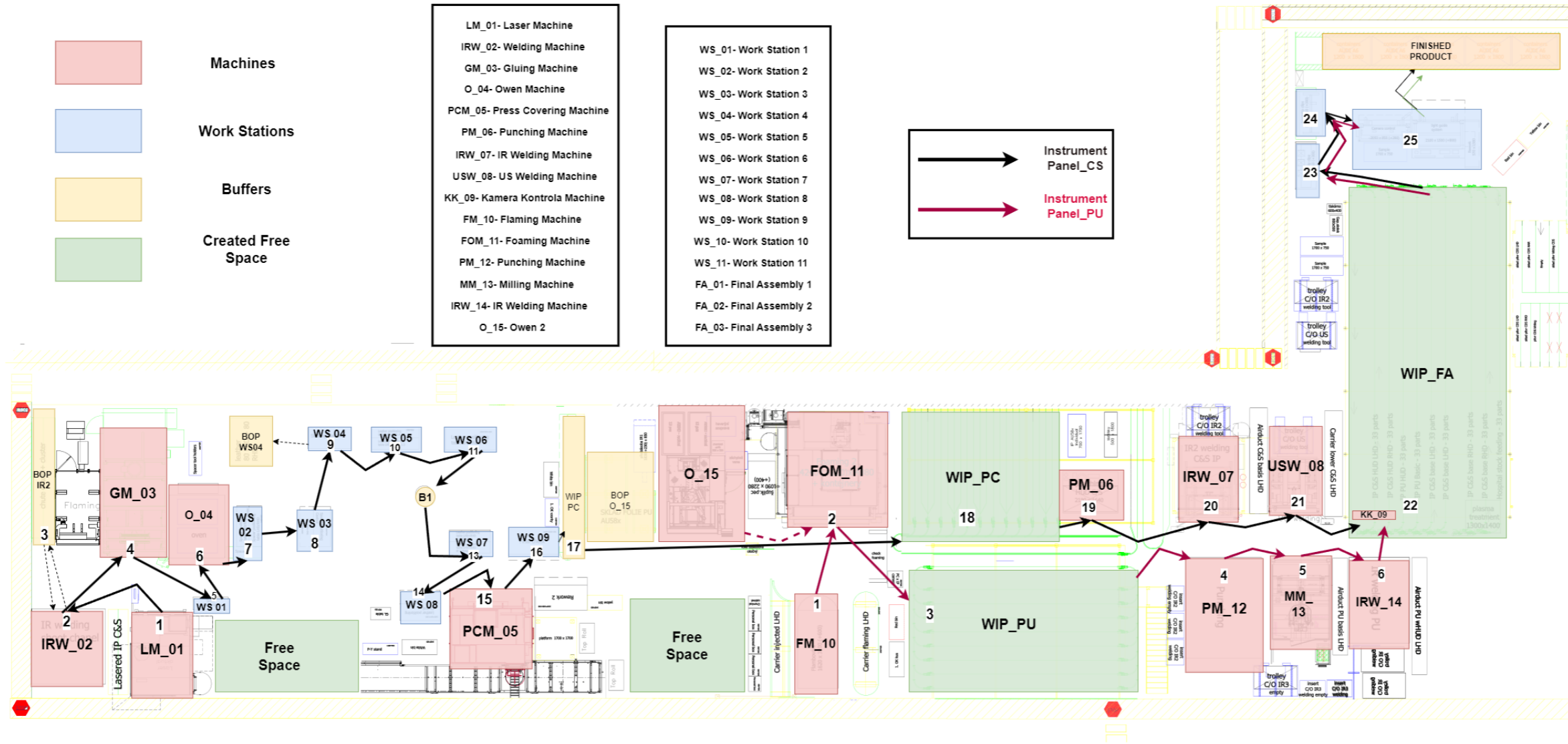

Attachment 3: Spaghetti Diagram (Ideal State)

