



Czech University of Life Sciences Prague

**Faculty of Tropical  
AgriSciences**

**Fog harvesting as an alternative source of water**

Bachelor Thesis

Prague 2018

**Author:**  
Šimon Klimuškin

**Supervisor:**  
Ing. Tatiana Ivanova, Ph.D.

## **Declaration**

I honestly declare that the bachelor Thesis titled “Fog harvesting as an alternative source of water” has been written on my own. The whole text is original and it is based on the data and information from scientific articles, publications and books, which are quoted in the last part of the Thesis according to the citation rules of the Faculty of Tropical AgriSciences.

In.....Date.....

.....  
Name of the student

## **Acknowledgements**

I would like to thank to my supervisor Ing. Tatiana Ivanova, Ph.D. for her guidance and supportive attitude during the writing of my Thesis. She had taught me a lot and for that, she has my gratitude. My thanks also belong to Ing. Lukáš Tůma for his advice and help with choosing a topic of my work.

## **Abstract**

The topic of the depleting water resources is highly serious. Scientists are agreed on a raising value of freshwater resources and they are estimating that the lack of water might cause a conflict in the future if amount of fresh water drops under a critical minimum in certain regions. The present Bachelor Thesis provides a general insight into depleting water resources and into increasing water demand with a future possible scenario to year the 2050. With use of two water scarcity indexes, water scarcity index (WSI) and country vulnerability index of water resources (CVIWR), the most vulnerable regions have been determined based on water resources information and socio-economic factors. In accordance with this evaluation, countries of Middle East and North Africa (MENA) have been determined as the most water vulnerable. Basic information about water resources, precipitation and drought situation are presented in the beginning of the Thesis. Subsequently, information about water collecting technology, technical aspects description, possible use, collection efficiency, different types of collecting materials, present and future possible potential of fog collectors to water management are provided as well. In the end of the Thesis, projects that were implemented in water vulnerable region of MENA countries and also in different other places are discussed. Impact of implemented collection system on lives of local people in terms of health, livelihood, economic situation and saved time is also presented. Part of the evaluation is also focused on primary use of collected water and comparison of the benefits for two main sectors, namely the use of water for personal/domestic use and for agricultural purposes.

The Bachelor Thesis was written as a literature review and all information contained are obtained from scientific articles or publications from scientific databases like EBSCO, ScienceDirect, Web of Knowledge and Springerlink with usage of key words.

**Key words:** fog harvesting, fog collection, fog collectors, fog, water scarcity

## Abstrakt

Problematika postupně mizících zásob pitné vody je velmi vážná. Vědci se shodují na rostoucí hodnotě zásob pitné vody a predikují, že v budoucnosti může dojít ke konfliktům, pokud zásoby vody klesnou pod kritické minimum v určitých oblastech. Tato bakalářská práce poskytuje obecný pohled na ubývající vodní zdroje a pravděpodobný scénář do roku 2050, stejně tak na růst poptávky po vodních zdrojích. Za použití dvou nejpoužívanějších ukazatelů úbytku vody - indexu ztráty vody (WSI) a indexu zranitelnosti vodních zdrojů, nejvíce postižené oblasti byly identifikovány. Hodnocení proběhlo na základě znalosti určitých faktorů, a sice zhodnocení vodních zdrojů a sumarizovaných socio-ekonomických aspektů. Díky těmto informacím byly za nejzranitelnější označeny země Středního Východu a Severní Afriky. Základní informace o vodních zdrojích, míře srážek a situaci ohledně sucha jsou poskytnuty na začátku práce. Navazující informace se týkají vody shromažďující technologie, popisu technické stránky, možného využití, sběrné efektivity, různých materiálů pro sběr vody a současný a budoucí potenciál využití. Na konci práce jsou vypsány projekty, které byly uskutečněny v zemích Středního Východu a Severní Afriky, ale i v jiných oblastech. Zde je součástí popisu zhodnocení vlivu sběrných systémů na zdraví, blahobyt, ekonomickou situaci místních obyvatel a ušetřený čas. Část zhodnocení je také zacíleno na primární využití získané vody a porovnání přínosu pro dva hlavních sektory, a to užití vody pro osobní účely a pro zemědělské účely.

Bakalářská práce byla sepsána formou literární rešerše. Všechny obsažené informace pochází z vědeckých článků a publikací, které byly nalezeny ve vědeckých databázích, například EBSCO, ScienceDirect, Web of Knowledge and Springerlink, za použití klíčových slov.

**Klíčová slova:** sklízení mlhy, sběr mlhy, sběrače mlhy, mlha, úbytek vody

## List of content

1. Introduction .....	2
2. Aim of Thesis .....	4
3. Methods .....	5
4. Literature review .....	6
4.1. Water issue in MENA countries .....	6
4.2. Fog harvesting .....	10
4.2.1. Fog in general (characteristics and creation) .....	10
4.2.2. Nature and fog water .....	11
4.2.3. History and development of fog collectors .....	13
4.2.4. Construction of passive flat fog collectors .....	16
4.2.5. Collection efficiency .....	18
4.2.6. Mashers in a fog collector .....	20
4.3. Use of fog collecting systems .....	26
4.3.1. Introduction of fog collecting systems .....	26
4.3.2. Quality of fog collected water .....	26
4.3.3. Fog collected water in agriculture .....	27
4.3.4. Contribution of fog collecting systems to community .....	28
4.3.5. Implemented projects in developing countries outside MENA .....	28
4.3.6. Fog harvesting practices in MENA countries .....	29
5. Conclusion .....	33
6. Reference .....	34

## List of figures

Figure 1. Leaves structure of <i>Cotula fallax</i> and water droplet formation process. ....	12
Figure 2. Schematic look onto cylindrical Falconer's type cylindrical collector.....	14
Figure 3. Actual photo of water collection device made from plastic material (PVC) of Falconer's fog collector.....	14
Figure 4. Schematic model of Falconer's type of fog collector .....	14
Figure 5. Schematic model of Juvik's type of fog collector .....	14
Figure 6. Schematic look of a bio-inspired fog collector with PCCW.....	15
Figure 7. SFC-Upper part of SFC .....	17
Figure 8. SFC-Lower part of SFC.....	17
Figure 9. Attachments of SFC.....	18
Figure 10. Details and dimensions of a typical Raschel mesh structure (in millimeters) ....	21
Figure 11. Water droplets formation in rectangular mesh.....	21
Figure 12. Water droplets formation in triangular Raschel mesh.....	21
Figure 13. Examples of across breakage on Raschel mesh: on the left side is shown an area near the frame and on the right is the middle part of a mesh. ....	22
Figure 14. (A) Raschel mesh pattern. (B) MIT-14 mesh pattern. (C) FogHa-Tin mesh pattern. ....	24

## 1. Introduction

Water scarcity is a problem appearing not only in arid and semi-arid areas, but also in areas with humid conditions (Rajaram 2015). Water scarcity is defined as water shortage in a water supply that leads to reducing population consumption of water (El Kharraz et al. 2012). This condition arises, when water demand is greater than water supply. The phenomenon of water scarcity might be caused by drought or anthropogenic actions such as population growth, water wasting and inaccessibility to water resources (El Kharraz et al. 2012). Increasing water consumption is responsible for depleting annual water runoff by 5 % (Haddela et al. 2013). Also populations eating habits and lifestyle are playing a significant role in the water demand issue. With raising tendency of consumerism it is clear that demand for water or products connected with water will grow. Different water potential is projected in diverse water consumption around the world, thus creating huge gap between developed and developing countries (Qadir et al. 2018).

Water scarcity is a huge problem threatening economic prosperity and food security in today's world of growing population (Shewe et al. 2013; Kharraz et al. 2012; Qadir et al. 2018). It is predicted that by the year 2050, water demand will be extended up to 55 %, caused by higher needs in manufacturing, thermal electricity generation and domestic use (Morichi et al. 2018). The challenge of this century is, that population will face fresh water availability in sufficient quality and quantity. Fresh water makes only 2.5 % of entire water on the Earth. Water content in the atmosphere is calculated to be 12,900 km<sup>3</sup>, which is equal to 0.001 % of total water resources and to 0.04 % of fresh water resources (Qadir et al. 2018). Fresh water sources are increasingly threatened by human activities and climate change. Multiple studies have also agreed on future raising level of water scarcity in following decades (Distefano & Kelly 2017; Shewe et al. 2013; Navarro-Ortega et al. 2014). According to the water crowding index (WCI), which measures annual water resources per capita in watersheds (Gosling et al. 2013), by the year 2050 due to climate change the amount of people facing the water scarcity problem will grow to a number between 0.5 billion to 3.1 billion people (Vörösmarty 2000).

We are dividing water conditions due to seriousness of water stress, accessibility to water resources that play a main role in the distinguish process. We consider situation as an absolute water scarcity when, people have access to the less than 500 m<sup>3</sup> of water per capita per year. Chronic water scarcity occurs, when accessibility is between 500 and 1,000 m<sup>3</sup> per capita per year. Water stress condition is, when water resources are 1,000-1,700 m<sup>3</sup> per capita per year and no water stress condition is in the range of 1,700 m<sup>3</sup> < per capita per year (Shewe et al. 2013; Brown & D. Matlock 2011). In the study from Siddiqi & Anadon (2011), a definition of water stress condition is described by the threshold of 1.000 m<sup>3</sup> per person per year. All values under this line are considered as water stress condition. It is estimated that 1.8 billion people will be facing absolute water scarcity and two-thirds of the world's population will have to deal with water stress problems connected with agriculture, industry, domestic sector, energy and environment



(Navarro-Ortega et al. 2014). From the abovementioned it is visible that the water scarcity and its availability is a serious problem, which becomes more and more alarming year to year. Thus, it is very important to study this topic as well as to look for new alternative solutions and technologies, as for example fog harvesting, which is a main focus of the present Thesis.

## **2. Aim of Thesis**

The aim of this Thesis was to summarize scientific information about decreasing water resources and a possible alternative solution such as fog harvesting. Furthermore, the aim was to evaluate and describe fog harvesting technology from a theoretical and practical perspective and to determine locations, where the implementation of collection systems makes the biggest contribution to the water management.

### **3. Methods**

The presented Thesis was written as a literature review consisting from the three main chapters, these chapters are: Water issue in MENA countries, Fog harvesting and Use of fog collection system.

The Thesis was elaborated according to the manual of the Faculty of Tropical AgriSciences for writing Bachelor's Thesis and all literature is cited in by the mandatory rules of the Faculty.

Processing of the Bachelor Thesis was based on searching of scientific information by using key words such as fog harvesting, fog collection, fog, water scarcity, etc. All information contained in the Thesis originates from scientific databases like ScienceDirect, Springer, EBSCO, Web of Knowledge. Referenced articles were mostly found in the following scientific journals: International Journal of Environmental Studies, Atmospheric research, Water and Environment and others. Final evaluation of contribution to the water management in water scarring regions was elaborated from the data published in the articles dedicated to real fog harvesting projects.

## 4. Literature review

### 4.1. Water issue in MENA countries

The most problematic places in the world due to the water scarcity are in the Middle East and North Africa, with designation MENA region. In this region the highest influence on scarce water resources has processes of salinization and desertification (El Khazzar et al. 2012). 13 countries from the Arab and African region are in a category of water shortage or water scarcity. The region has run out of reserves of fresh water resources in 70s, which led to a huge reduction of the water supply (El Kharraz et al. 2012).

Besides WCI (mentioned in the Introduction), there is a country vulnerability index of water resources (CVIWR), which presents summarization of more factors: 1) governance, 2) socio-economic, 3) environmental risk, 4) water scarcity, 5) external water footprint, 6) water energy (Al-Saidi et al. 2016).

Explanation of these six factors see down below:

- 1) Economic distress a vulnerability to unrest.
- 2) Represented by human development index.
- 3) Drought seriousness (length of droughts, variations in water supply, annual precipitations, flood occurrence).
- 4) Ratio of water withdrawals to water availability.
- 5) Ratio external to total water footprint multiplied by the value of water scarcity.
- 6) Long term energy sufficiency, fossil revenues dependency, economic power (Al-Saidi et al. 2016).

Outcome of CVIWR is scale from 0-1; when numbers from 1-0.76 are indicating extreme vulnerability, 0.75-0.51 indicates high vulnerability, 0.50-0.26 shows moderate vulnerability and 0.25-0 indicates low vulnerability. This index brings more complex view on water situation in selected countries. Most of the MENA countries share the same vulnerability problems, water scarcity, fragile governance and effort to mitigate current situation. MENA countries are divided in two groups. First and more rich are the countries from the Gulf region (Al-Saidi et al. 2016). Reason for higher capital is not surprisingly crude oil. Not meaning, that other MENA countries don't have resources of crude oil, but countries of Gulf have just bigger reserves. Apart from that existence of Gulf Cooperation Council (GCC), that plays a big role. GCC is organization consisting of six Arabic countries, such as Saudi Arabia, Bahrain, Kuwait, Oman, United Arab Emirates and Qatar. Only two from these six countries are not in OPEC organization (Oman and Bahrain). All these six countries together own 47 % of the worldwide resources of crude oil. Cooperation of these oil magnates, with owing almost half of the world's resources gives them plenty of space to create price for oil on a market. This is obviously resulting in high profits and more developed economy. Bigger capital offers more possibilities how to deal with problems, including water scarcity. So, they are solving the problem by spending capital for example on embedded water,

desalination seawater plants or investments into new technologies (Mohanty et al. 2011). Poorer countries are investing in import of food to save water resources. Due to CVIWR none of the MENA countries is classified as extremely vulnerable, but Egypt, Iran, Iraq, Syria, Morocco, Yemen and Libya are in the class of high vulnerability. From the result it is estimated that, Iraq is the most vulnerable among MENA countries. Now we will take a closer look at the most water scarce Arab and African regions separately (Al-Saidi et al. 2016).

**Iraq**, the biggest problems that the country is facing are external water footprint, governance and high water scarcity. Iraq is not spending relevant amount of money to import water goods (Al-Saidi et al. 2016). Iraq struggles with very high temperatures, in the period from July to August temperatures rise to 43 °C. During the winter temperatures drop to only 16-20 °C, and with a combination of low rainfall it causes a water deficit issue. In 1970 a new problem occurred when The Turkey program was started, during the program Turkey has built 22 dams on the Euphrates and Tigris rivers. Both rivers are water resources for Iraq. This water flow reduction has led to a cut in water flow to Iraq by 50 % and also increases the level of salinity. Highest water shortages have been documented in the period between 2007-2009. In this period high numbers of agricultural oriented population in areas of Euphrates and Tigris were forced to move into different places with higher water availability. Also, in 2014 water and economical instabilities appeared, when the war with Islamic State (ISIS) was in progress. ISIS took over some water reservoirs, which resulted in decreased water supply. Fortunately by the year 2017 Iraqi forces were able to oust ISIS and restore water resources (Aljanabi et al. 2018).

**Syria** has less than 250 mm of average rainfall dropping on m<sup>2</sup>. Total volume of renewable potential water in the country is 16.8 km<sup>3</sup>/year. The total amount is summation of renewable surface water and renewable ground water. But 60 % of total water source comes from outside of Syria. One of the biggest sources for Syria is Euphrates river, which rises in Armenian highlands and the width of the river is in a range between 50 and 150 meters. It is pouring to Tigris river, which ends in the Persian Gulf. Euphrates' average discharge has been constantly dropping and during 1937-1989 it was mildly under 1,000 m<sup>3</sup> per second. And, for the period from 1989 to 2010 an average discharge has been reduced slightly under 700m<sup>3</sup> per second. Observations from 1937-2010 are showing how quickly are the potential resources of fresh water dropping. One of the reasons might be relatively rapidly growing population of Syria, which led to almost 22 million people in 2011. This year is unfortunately connected to the tragic event of Syrian civil war, which stopped the population grow than started its rapidly dropping afterwards (Gleick, 2014). After three years, since the conflict has started, 125,000 people died and almost one third of the total population has left the country or has been banished (Jenkins 2014).

**Morocco** has an issue with rising temperature, resulting in decreasing ground water resources and current drought episodes. It is documented that from the year 1961 temperature increased by 0.2-0.4 °C per decade. Increasing temperature and decreasing rainfall per m<sup>2</sup> per year is the reason for the predicted worsening of the

situation of water resources in Morocco. Climate projections by the National Directorate of Meteorology are predicting a rise in temperature by 2-6 °C and a 20 % reduction of average rainfall from today's situation. These worsening conditions highly influenced agricultural activity such as degradation and lesser productivity of land. For example in the agricultural region Marrakech-Tensift-Al Haouz, which is located in Northern Morocco with almost half of the regions precipitation rate under 300 mm/m<sup>2</sup> per year. This low income of rainfall with a combination of droughts and high temperatures is decreasing groundwater resources. Farmers are forced to obtain water from underground resources by pumping, which is more expensive and also the quality of water is not optimal. Another problem is the documented decreased level of Tensift river, which is a great source of water to this area (Kahime et al. 2018). Morocco exhibits a sizable internal water footprint and low energy income. These two factors appearing together make water scarcity a huge risk for the country (Tamea et al. 2014).

**Yemen** suffers from limited drinking water resources and high ground water pollution. Water quality is mostly affected by climate, management of land, landscape, hazardous waste sites and badly managed domestic and industrial waste. It is estimated that rapid depletion of groundwater and with the same rate of consumption for all sectors, water will not be available for many people (Al Aizari et al. 2017). The situation is also serious on the governance and socio-economic performance, it is mainly oriented on decreasing water scarcity by operating with virtual water (Al-Saidi et al. 2016). Virtual water is used in international trade of food commodities, where countries are able to virtually operate with a volume of water, which would be spent on producing food because, agricultural sector burdens most of the water demands. Virtual water fluxes connected with food trade could be very useful. Studying water trade combined with water footprint and comprehensive sustainability assessments could help with outcome of integrated policy options, problems related to climate change or proper use of resources (Tamea et al. 2014).

**Libya**, country with 90 % of total area covered by Sahara desert. The country's biggest water supply comes from rainfall water and groundwater, which is mainly accumulated in four sandstone aquifers (Kufra, Sirt, Morzuk and Nubian). Population of 5.5 million people and average rainfall of 56 mm per year is in the driest areas. More wet areas with higher precipitation occurrence are located in the north of the country, where an average rainfall is higher and it is estimated to vary from more than 100 mm per year to 250-300 mm per year (Aqeil et al. 2012). Libya's total fresh water resources are calculated to be 3,820 million m<sup>3</sup> per year, but almost 200 million m<sup>3</sup> of runoff evaporates due to the dry climate. According to the study by Aqeil et al. (2012) if Libya continues with the same water consumption in combination with the growing population and water requirements mostly for agricultural, industrial and domestic sectors, some serious outcomes will appear. Libya will then reach to water demands of 8,200-8,480 million m<sup>3</sup> per year. From that amount, more than a half (estimated to be 4339 m<sup>3</sup>) will be used for industrial and domestic purposes. The same as other developing countries, Libya has growing population, which burdens water reserves. 85 % from the total water use is used for agriculture, however it is not the strongest sector of the

country. Agriculture makes only 10 % of a global income of Libya. Libya in the effort to become a strong independent country is trying to shortage the share of an agricultural sector, which is also connected with cutting the water demand. But it still needs to keep agricultural sector big enough to produce enough food to supply the country (Aqeil et al. 2012).

But not all problematic places are in the region of MENA countries, in Euro-Mediterranean climate zone is appearing drought caused by increasing freshwater demand which naturally leads to decreasing freshwater flows in estuaries. Water scarcity, not only that shortage of water resources for population, but it can also change the right function of macro fauna, which is inhabited by fish, decapod, mysid crustaceans (Ortegón et al., 2014). Mediterranean climatic area contains a great number of badly managed water resources. Approximately two thirds of water used in this area is not being managed in proper way. Up to half of total managed water is under poor ecological condition. Main reason for that is an annual climatic variability. Besides, almost one half of lands profiting from agricultural activity is under water scarcity effect annually (Garrote et al. 2015). The period from 2005 to 2015 is considered as one of the hottest overall. In some areas of Southern Europa, these hot conditions were the reason of the harvest failure and a water imbalance (Donatelli et al. 2015).

The proof of the worsening situation in Spain is supported by the Spanish government decision from 2002 to start irrigation stimulating program and emergency plan for modernization of irrigation systems. The main objective of this act was to save 3,000 million m<sup>3</sup> of water per year. That is facilitation to 2 million ha from total irrigated area of Spain, which is spread out in 3.5 million ha. The major principle of an action like this is to replace an old and less efficient irrigation system with a new more efficient water supplying system. This process might contain for example automation of irrigated district (García et al. 2013).

Overall countries with water scarcity difficulties in effort to decrease water shortages have few options. Countries that have enough capital, like Saudi Arabia or United Arab Emirates can deal with water scarcity by investing in expensive technologies for example, desalinating seawater plants, embedding water or spend money on research of new technologies (Al-Saidi et al. 2016, Gleick 2014). Those countries, that don't have enough capital, like Iraq, Yemen, etc. should look for new and cheap ways how to increase water resources and deliver water to people (Al-Saidi et al. 2016).

For example contribution from fog system to water circulation is well known for a long time, but fog harvesting using fog collectors is a relatively new field, with necessity of a further research, which seems promising, possible and cheap way to extract water for people in need. There might be a huge potential in harvesting fog water (Domen et al 2014). One of the reasons is that fog harvesting technologies are on a raise and the whole sector is the least examined leaving a space for future research and possible achievements. Other reason is, just the fact about share of water in atmosphere. It is estimated, that 12,900 km<sup>3</sup> is contained in atmosphere,

which is equal to 0.001 % of total volume of water in the world and 0.04 % of total freshwater resources (Qadir et al. 2018).

## 4.2. Fog harvesting

### 4.2.1. Fog in general (characteristics and creation)

Fog is described as a cloud with physical contact with the Earth's ground (Scholl et al. 2010; Pospíšilová 2012). The main reason of the fog formation is presence of hygroscopic condensation nucleus for condensation of water vapor. Relative humidity of air is about 90-95 %, near to dew point, but not above. For fog creation is important a various relief of surface, because obstacles are forming the movement of air. Force of air can change the dispersion of fog. More fog is created in valleys and near the water flows. In big cities the fog composition is influenced by industrial dust. Fog has almost the same composition as an air cloud called "*stratus*", but with smaller percentage of water particles. The volume of water in fog cloud is less than 0.2 g/m<sup>3</sup>. It is estimated that few hundreds of droplets is concentrated in m<sup>3</sup> (Pospíšilová 2012). The diameters of water droplets that form the cloud are typically between 1-10 µm (Klemm et al. 2012). But in the newer study have been stated that fog is formed from micro-size water droplets with diameter  $D_d = 5-50 \mu\text{m}$  (Regalado & Ritter 2016) and Frumau et al. (2010) are claiming that the size of water droplets forming the fog is smaller than 40 µm. So, the first study is saying that a cloud is formed from the smallest sized droplets and all three studies are able to agree on water droplets sized in the range of 5-10 µm. Fog could also appear in various form of intensity. The four stages are divided by visibility. Exactly by the distance, when we are still able to see black object in angle distance between 0.5-5°. Visible object to 50 m is indicating very strong fog. 50-200 m visibility is strong fog. 200-500 m is mild fog and 500-1000 m is feeble fog (Scholl et al. 2010, Pospíšilová 2012). Definition by visibility distance is formed more from meteorological point of view, because this information does not carry the aspect, if there is measurable precipitation from the fog cloud. Hydrological point of view is focused more on the size of droplets. Another study sets the difference between size of water droplets' diameters of fog and rain. Upper size limit for fog is 0.2 mm and the rain droplets size is estimated to be more than 0.5 mm. Rain droplets are too big and heavy to be able to stay in the cloud and they fall down towards to the Earth's surface (Scholl et al. 2010). We are dividing the fog by the way it is created into 3 groups:

- 1) Radiation fog
- 2) Evaporation fog
- 3) Advection fog

1) Is created when a lower layer of atmosphere is cooling down, so the Earth's surface temperature is decreasing that leads to the increasing relative air humidity as well as saturation condition. This effect is also called isobaric air temperature drop. This condition is affected by thermo-dynamic forces. During the condensation of water steam a latent heat is being loosened. This type of fog is



mostly present in autumn and in winter months (Morichi et al. 2018). We also divide radiation fog to ground, inverse, radio-advection and hillside fog. Hillside fog or orographic fog has the ability to carry the most volume of water per m<sup>3</sup>. This part of the Earth's surface is connected with strong winds, which are able to carry or uplift bigger sized water droplets. So, the total volume of water inside the cloud is higher comparing to the rest of fog's types (Pospíšilová 2012). According to Morichi et al. (2018) orographic fog is not a part of radiation fog, and its creation is taking place, when the warm and humid air is moving towards to mountains, then it collide with mountain slope, ascend to higher position and gets cooled down.

2) Mostly common type of fog in sea sides next to the glaciers. It appears when warmer water from lakes and rivers is transporting a heat to the colder air. In this category is fog created from transiting fronts, during this process, humidity of air is increasing from precipitation and vaporization. Evaporation fog is divided in three groups: pre-frontal, after-frontal and frontal (Pospíšilová 2012).

3) Advection fog is always connected with horizontal movements of air flows. It is appearing, when warm humid air is moving above the colder surface and the temperature of the air is decreasing, because of the difference between the temperatures. We divide them into tropic, arctic and sea fog (Pospíšilová 2012; Qadir et al. 2018). Fog is described as a cloud with physical contact with the Earth's ground (Scholl et al. 2010; Pospíšilová 2012).

#### 4.2.2. Nature and fog water

Principle of collecting water from the fog goes way before the time, when fog started to be collected for population purposes. Trees are able to absorb water form from the fog, and in some places they survive only because of fog water. For example, in American Pacific coastal area there is a high amount of coniferous woods. They benefit from intercepting fog water, because most of rainfall precipitation is consumed by scrub vegetation. Another example is from northern coastal hills in Peru and Chile, where the type of woods is called loma. This area is almost without precipitations and vegetation staying alive mostly, because of seawater fog. Trees are basically natural fog collectors, where efficiency depends on two factors, height and leaf structure. High trees with a needle type structure of leaf tend to absorb more moisture. Other factors like horizontal wind speed and the size of water droplets take part as well (Fessehaye et al. 2013). In nature there are also more strategies used by plants to absorb water. Difference in absorbing water is caused by character of the leaf. Leaves of plant could be hydrophobic or hydrophilic. For example, the lotus leaf effect is based on super hydrophobic character of the leaf. Water content is being intercepted by 3D form of the leaf and after the leaf is totally filled, a weight of the water bends the leaf and water is spilled down towards the ground, where it is absorbed by the plant's roots. Another interesting example is alpine plant *Cotula fallax* originally from South Africa; this low height plant has biternate leaf structure, which is ideal for capturing water. Space between steam and laves is filled with a hair, which increases a capture area. Process of intercepting water from leaves is almost the

same as passive fog collecting gauges are using. Small water droplets from fog are captured on a leaf area, then due to coalescence power they form to one bigger water droplet and when water droplet is too heavy, it slides down to soil and it is followed absorbed by plants roots (Andrews et al. 2011). Visible explanation of this process is presented in Fig. 3.

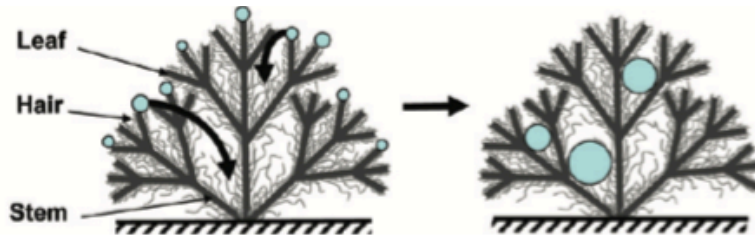

Figure 1. Leaves structure of *Cotula fallax* and water droplet formation process.

Source: Andrews et al. 2011

But not only trees and plants are using fog as a source of water, few animal species inhabiting arid areas have adapted to inconvenient conditions by intercepting water droplets from fog. Namib Desert beetle (*Onymacris unguicularis*) is inhabiting area, where annual rainfall is 12 mm/m<sup>2</sup> per year, using his body structure. His back layer has hydrophobic effects and the back is also covered with hydrophilic bumps, which cause the collection of fog water. Collected water is then draining down in channels made from bumps (Domen et al. 2014). Namib Desert is one of the driest places on the Earth. Rainfall is very low and very unpredictable, but fog moving from Southern Atlantic is able to reach up to 100 km inland and appear from 60 to 200 days per year. Organisms can consume water directly or indirectly, most of them are drinking water droplets, that have been attached on leaves, but Namib beetle and Namib dune bushman grass (*Stipagrostis sabulicola*) are doing it directly. Lund University in Sweden made an experiment about water collection efficiency between Namib beetle and Namib dune bushman grass, in order to see the difference in collecting efficiency. Samples of live beetles and grass were collected with co-operation with National museum of Namibia. As an outcome of experiment it was stated that Namib beetle is less efficient in collecting water than bushman grass. Results were compared in volume of intercepted water from the same collecting area (mm<sup>2</sup>) in two hour period. Beetle has collected 60.51±15.14 µL and bushman grass has collected significantly more, 111.94±44.53 µL (NØrgaard et al. 2012). Nature is giving us proofs about function of water collection and also inspires on a field of making water collection systems (Domen et al. 2014).

In today's world with tendency of growing population and increasing demand for fresh water as a resource, where it is estimated that almost one third of the global population is experiencing water stress problems, it is important to look for new and sustainable alternatives of obtaining fresh water. One of potential sources of

fresh water is fog. As advantages of fog harvesting we can count the facts like low cost system, passive and low maintenance system. This technology has potential to deliver fresh water to communities and also to be a supplement of rainfall in arid areas for reforestation projects (Domen et al. 2014).

#### 4.2.3. History and development of fog collectors

Technology of harvesting water from fog goes back in our past. It is estimated, that two thousand years ago, local inhabitant of Canary Island noticed water droplets caught on tree leaves and used them for drinking purpose. Obviously, we can't talk about intentional fog harvesting, but it is the first documented action of people using water content from fog. So, fog as source of water is well known for a long time, but aimed utilization is relatively new field. First documented experiment focused on contribution from fog to water management was conducted in Africa in the beginning of 20th century. Between the years 1901-1904, a project in Africa was testing, if water intercepted from fog cloud is considerable source to shortage common water sources (Qadir et al. 2018). As a beginning of fog harvesting we can determine invention of water droplets intercepting nest discovered by Chilean scientist Carlos Espinosa in 1957. His goal was to create cheap and useful way to provide potable water for poor people with obstacles in obtaining fresh drinkable water (Wahab & Lea 2008; Leboeuf & De La Jara 2014). At the beginning, devices weren't developed enough, which was reflected in collection efficiency. During the time, the whole technology went through vehement development. As it was mentioned before the technology was invented in Chile, so most of the experiments that took a part till 1988 had been conducted in Chile. During this time, different types of fog collector devices were tried in different weather conditions (most frequently used type was 2-D flat rectangular collector), this type is still the most used till present. The range of altitude that collectors were tried in was 530-980 meters above the sea level. As a result of these experiment, fog collectors were considered as a feasible and applicable way to gather water. Usage of collected water is various; it could be used for drinking, commercial, agricultural or environmental purposes. Different types of fog collectors are ideal in different destinations (Leboeuf & De La Jara 2014).

In 1980 a cylindrical type of fog collector has been developed as a reaction to fog problems with wind direction. Problem of passive collectors is that under some angles collection efficiency is almost zero. As a solution for dependence on wind direction, omnidirectional collectors were developed with basic idea to increase collection efficiency in places with various wind flow directions. Two cylindrical types were named after their inventors: Juvik's type and Falconer's type. Differences between these types are material of fibers and pattern. Falconer type has only vertically placed fibers, towards to ground, made from fishing line with application of Teflon to increase hydrophobicity; fibers are attached to polypropylene disks, which make collector stable. Juvik's type of collecting mesh is made from metal material with horizontal and vertical filaments. Collection part, placed in a bottom of collectors is for both types the same, and plastic gutters are

pouring the water to container (Fisher & Still 2007). Detail look of collectors can be seen in Figures 2-5.

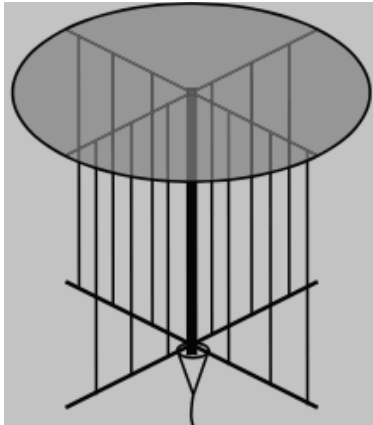

Figure 2. Schematic look onto cylindrical Falconer's type cylindrical collector.

Source: Fisher & Still 2007



Figure 3. Actual photo of water collection device made from plastic material (PVC) of Falconer's fog collector.

Source: Fisher & Still 2007

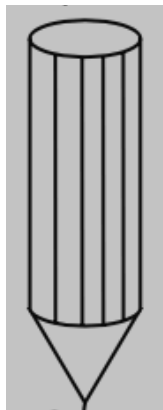

Figure 4. Schematic model of Falconer's type of fog collector.

Source: Fisher & Still 2007

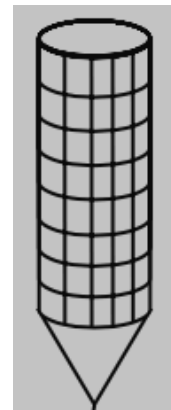

Figure 5. Schematic model of Juvik's type of fog collector.

Source: Fisher & Still 2007

According to Fisher & Still (2007) cylindrical shaped collectors are not affected by the wind direction and have smaller evaporation rate than flat collectors, but total collection efficiency seems to be lower than total collection efficiency of flat collector. Based on the fact that in all articles that I have found, cylindrical collectors are only part of research not practice, I am assuming that they are not used often and their collections rate hasn't proved to be relevant or further research is needed.

Future of fog collection is on a raise and a lot of space for possible improvement is available. As the most promising research sector seems to be material of the mesh. Description of two new very promising materials is offered in the chapter (4.2.6.4.) (Fernandez et al. 2018). Another interesting field is a new type of fog collector inspired by water transportation of cactus. Still, the most widely used type of fog collectors is passive flat collector, however, this type has several problems causing water loss, when water droplet is intercepted by flat mesh, it depends on adhesive forces and coalescence to create one bigger droplet from the small ones, big enough to overcome adhesion force and slide down from mesh to gutter and then to container. This process takes a while and during this time water content could be blown away from mesh or evaporated. Water is simply not protected from outside influences. As an interesting idea, which has appeared in 2014, when fog collector with water collection system similar to cactus water transportation was taken into account and the conical spine for collection was invented. The core of this new idea is that, due to the lesser roughness of fibers, after the capturing water droplets form in a bigger droplet in shorter time and slide to a collection gutter much quicker, which leads to higher collection efficiency thanks to smaller loss of water content through evaporation as well as loss by wind forces. New type of fiber is made from conical copper wire (PCCW). Wire could be placed in various angles but according to the study from Xu et al. (2016) the best angle for coalescence and sliding to gutter is zero angle with horizontal axis. Example of new type of fog collector is demonstrated in Figure 6 (Xu et al. 2016).

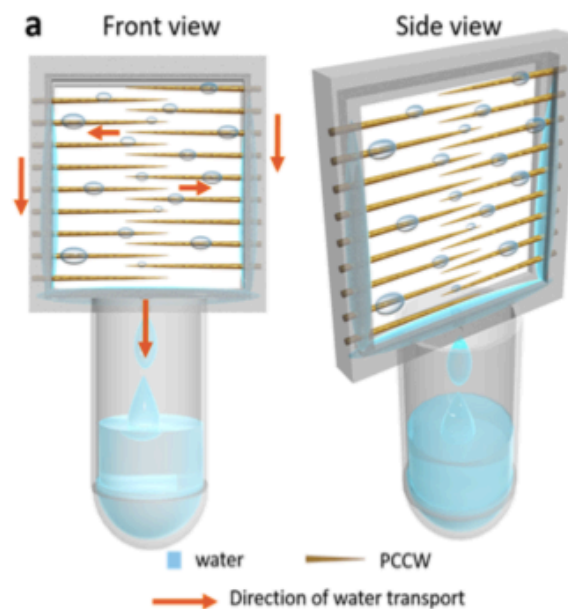

Figure 6. Schematic look of a bio-inspired fog collector with PCCW.

Source: Xu et al. 2016

Fog harvesting has no long history of using fog collectors, although water is being intercepted by nature, i.e. animals, vegetation from the beginning of their existence. Now water is harvested in 17 countries from all over the world. Fog collectors

have great potential to help with supplying water the growing water demand by every year. Globally used fog collectors have water collection efficiency between 1-12 L/m<sup>2</sup> per day. There are documented experiments on new type of metal meshes, which are resulting in high collection efficiency of 54 L/m<sup>2</sup> per day. However, up to now they haven't been integrated in global use, due to high cost or complicated building process; one thing is without doubt, fog harvesting trough fog collectors brings significant contribution to water resources (Qadir et al. 2018; Ghosh & Ganguly 2018).

The most used type of collectors for practical water collection up to now is **Large fog collector** (LFC) in the range of 40-48 m<sup>2</sup>, equipped with Raschel mesh, single or double layer, with 35 % shade coefficient. This material provides the best combination of cheap material and collection efficiency (Fernandez et al. 2018; Rivera & Lopez-Garcia 2014).

#### 4.2.4. Construction of passive flat fog collectors

**Standard fog collector** or small fog collector (SFC) is used mostly in the research field and to evaluate collection efficiency and quality of water (Klemm et al. 2012). The size of SFC is constructed from 1 m x 1 m frame, measured from inner side, which is filled with mesh. Width of the frame is 1 cm and material supposed to be metal, recommended type is aluminum, because of its anti-corrosion effect. Frame is connected with 2 m high support base and the distance between frame and base should be at least 0.1 m to avoid contact between mesh and support structure during the higher speed of wind. Below the frame is installed a trough of 1.04 m long, 0.15 m wide and 0.1 m deep collecting fog water, which is moving down from the mesh. Through should be close-fitting to frame on the windward site and the edges of through and frame should be in the same position. This position should prevent mixing of water collected from the mash with rainfall. Through is connected with drainage tube with inner diameter 7-10 mm. This specific range is important, because lesser range wouldn't let sediments to go throw without sticking the tube. Tube drainage is connected with storage place and can accumulate enough volume of water (Domen et al. 2014).

Mostly used materials for collecting mesh are polymers (polypropylene and polyethylene) due to the cheap price and relative accessibility all over the world. Passive flat fog collectors are installed in recommended impact angle (90°). Perpendicular impaction angle of passive flat fog collector and wind direction was documented as a most efficient between wind and collecting area. SFCs attached to ground with only one post are also documented. Collectors are not passive and are able to move due to a wind changing direction. From accessible information it is evident that use of these active collectors is not common thing because of demands for maintenance and higher price. This type was designed by Shemenauer and Cereceda (Domen et al. 2014). Approximately a life span of polymer collecting mesh is estimated to be in range between 3-10 years. Highly depends on a local condition. It is documented that in the mountain regions, with common stronger

and faster blowing wind, life span is longer than in the low lands. Exact look of SFC design is shown in Figures 7 and 8.

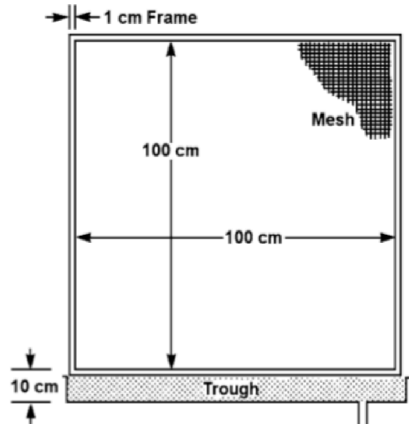

Figure 7. SFC-Upper part of SFC.

Source: Domen et al. 2014

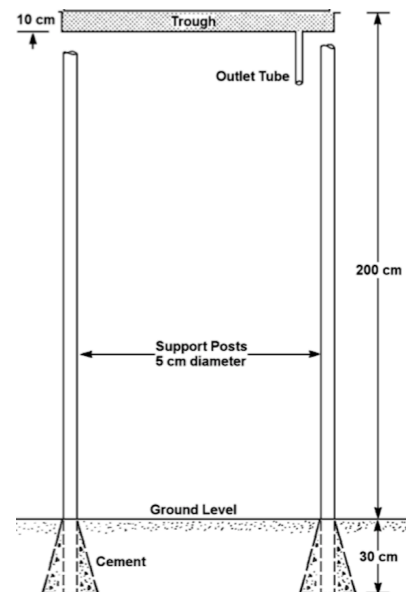

Figure 8. SFC- Lower part of SFC.

Source: Domen et al. 2014

As an object of research, SFC is mostly equipped with some attachments for data collection. Often anemometer is installed. Anemometer serves as a wind speed and wind direction gauge. Another gauges commonly used are tipping bucket or data logger that supposed to clarify site-specific fog water collection characteristic and another devices, which help with collection characterization. More detailed presentation is provided in Figure 9. Tests that had been performed on SFC are resulted in average collection efficiency, which is stated to be in average in the range from 1-10 L/m<sup>2</sup> per day from vertical collection surface. The highest collection efficiency was measured as 300 L/m<sup>2</sup> per day. But this high efficiency was caused by combination of dense fog and drizzle or light rain (Wahab & Lea 2008).

One of the purposes of an attachment is to identify water collected from fog and water collected from rainfall, so that collection efficiency can be set properly. Collected samples are sent once a day via communication modem to central receiving office. As it was written earlier, sometimes water collection efficiency could be increased by the presence of a rain and fog together (Estrela et al. 2008). This is not a problem while using LFC, that are made for collection purposes only and the main goal is just to collect maximum amount of possible water content (Holmes at al. 2014; Klemm et al. 2012), but for explorative purposes of SFC it is important to separate water content from fog and water content from the rainfall. To achieve this goal a data reduction technique is used. When rainfall and fog are plotted, we use normalised volume index (NVI) to express fog content:

$$NVI = \frac{F - r}{F + r}$$

Where: F - is volume of fog water collected by SFC;  
 r - is rainfall water collected by rain gauge of SFC.

Index outcome is in the range of -1 and + 1, meaning no fog water content and maximum fog water content (Estrela et al. 2008).

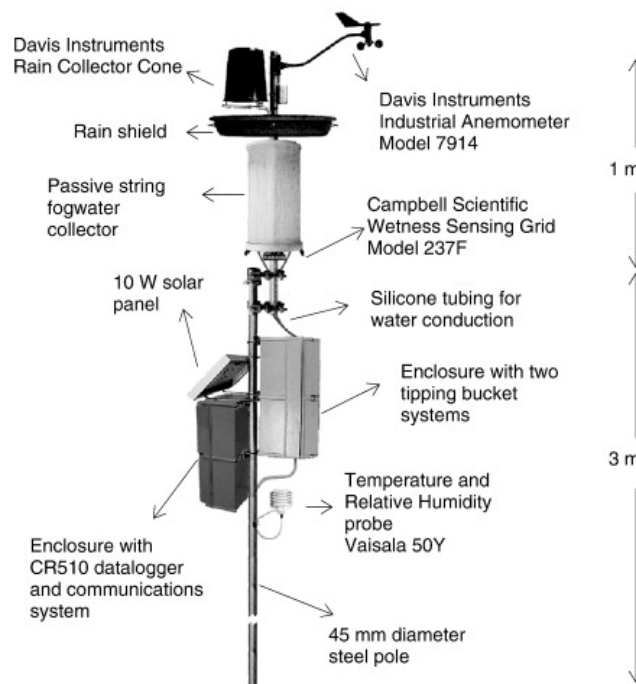

Figure 9. Attachments of SFC.

Source: Estrela et al. 2008

#### 4.2.5. Collection efficiency

Fog collection efficiency is mainly influenced by the wind speed and the fog droplet size (Morichi et al. 2018). There are two possible ways how to express the total water collection efficiency. The first one is multiplication of aerodynamics, capture and draining efficiencies. None of these three efficiencies overcome 100 % (Rajaram et al. 2016). All these factors are taken as a multiplicative constituent (Regalado & Ritter, 2016).

$$\eta_{tot} = \eta_a \times \eta_{cap} \times \eta_{dra}$$



Where:  $\eta_a$  - aerodynamics efficiency;  
 $\eta_{cap}$  - capture efficiency;  
 $\eta_{dra}$  - draining efficiency.

All of these three factors need to be counted through multiple equations, but capture efficiency equation is conducted only for cylindrical type of fog collector as according to the research of Wyslouzil et al. (1997). So it is not applicable to the most used type of collectors, i.e. flat passive collector, so I don't see significant reason for writing it all down. Further more research is needed in capture efficiency calculation (Fernandez et al. 2018).

The second way, more direct, is a fraction of actual collection rate (c) and available water flux ( $c_{avail}$ ) meaning actual amount of collected water divided by maximum possible amount of water that could be collected (Leboeuf & De La Jara 2014). Thus, the collection efficiency is expressed as follows:

$$\eta_{tot} = C / C_{avail}$$

Where: c – is real amount of captured water;  
 $c_{avail}$  – maximum possible volume of fog water content, that could be intercepted.

Water content intercept by fog collector is mostly expressed as how much water can 1 m<sup>2</sup> collect per day (Leboeuf & De La Jara 2014).

**Aerodynamics efficiency** plays a big role in total efficiency. For example, aerodynamic efficiency of solid plate without any holes and air through flow is only 9 %. For a typical Raschel mesh it is 20 % with shade coefficient (SC) between 35 and 37 %. Efficiency could be improved by increasing SC to 55 %, this leads to the higher aerodynamics efficiency about 24.5 %. SC is expressed as friction of fibers area divided by total mesh area. Optimization of devices collecting a fog water haven't been fully explored apart from few exceptions. Most of the studies are focused on aerodynamics of triangular knitted Raschel mesh fog collector (Regalado & Ritter, 2016), i.e. fraction of fog collectors cross sectional area normal divided by the wind occluded by mesh material (Regalado & Ritter, 2016). Aerodynamics efficiency has its maximum value, which is expressed by the drop coefficient, so the maximum efficient value is  $C_{D\ critical} \approx 3.1$ . After exceeding this value, mesh of the fog collector would not be able to intercept water droplets properly and most of the droplets will pass through with wind direction (Park et al. 2013).

**Capture efficiency** or few other terms are used in this case. Probably more accurate designation is deposit efficiency; this term was mentioned in the study of Holmes et al. (2014). Another possible designation is impaction collection efficiency, but all these three terms are describing the same process (Regalado & Ritter 2016). This efficiency describes how well the mesh fibers are able to intercept water droplets. General summarization of this term sounds that capture

efficiency grows with decreasing diameter of fibers and increasing wind speed (Holmes et al. 2014).

**Draining efficiency** is described as a fraction of volume of the water that have been deposited and after that drained to the gutter placed below the mesh, by the mesh's filaments (Regalado & Ritter 2016).

#### 4.2.6. Mashers in a fog collector

##### 4.2.6.1. Types of mashers and materials

Material, which is used for the mesh of fog collector, is mainly made from hydrophobic material. Water droplets are caught on a fiber, but after that a fiber cannot absorb the water because that would substantially decrease collection efficiency. Convenient materials are for example, nylon (Andrews et al. 2011), polyethylene (Klemm et al. 2012), steel wire mesh or polypropylene mesh (Fernandez et al. 2018) or copper wire (Xu et al. 2016).

Two types of mesh attachment are known. Mesh is connected to the rigid frame by elastic connectors or the mesh is connected to the frame from elastic cables and then to the posts (Rivera & Lopez-Garcia 2014). Second type of attachment is used in areas with higher velocity of wind. The reason is that the cable frame is more flexible and more capable to reduce wind forces.

The knitting model of the Raschel mesh makes significant anisotropy to its mechanical function. In horizontal way the fibers are continuous. In vertical way they are not continuous and are joined into the longitudinal ones. So, when the wind force starts to affect the Raschel mesh it is estimated that elongation will project vertical not horizontal way. Thus, when mesh is being stretched in vertical way, the horizontal fibers will deform at the right angle to their axis, i.e. the way, which every fiber has low resistance, and the knots of vertical fibers onto the horizontal ones will tighten. These two actions formed together are heading to permanent deformation. And, the result is an elongation in vertical way and contraction in horizontal way (Rivera & Lopez-Garcia 2014). Also proportions of a fiber play a big role in collection efficiency (weight, length, thickness, spacing); precise dimension see in Figure 10.

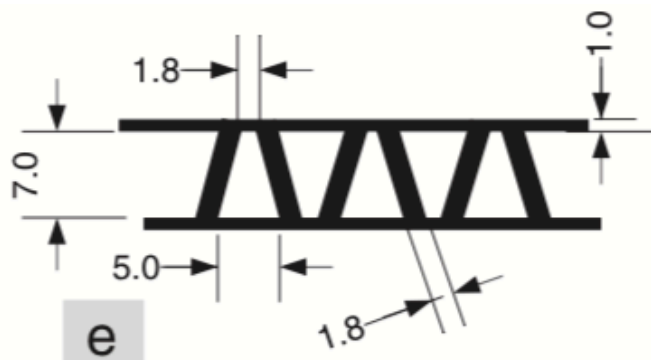

Figure 10. Details and dimensions of a typical Raschel mesh structure (in millimeters)

Source: Holmes et al. 2014

#### 4.2.6.2. Water droplets formation in meshes

Two main types of a mesh with different water droplets forming are mostly used. Mesh with rectangular knitting and circle fibers and typical Raschel mesh with triangular knitting and rectangular fibers. Principle is the same for both patterns, but the process is a little bit different. Larger water droplets that are draining into gutter due to its size are formed from smaller water droplets due to coalescence force. In case of rectangular mesh the larger water droplet is formed exactly in the middle of the pore and in case of triangular Raschel mesh smaller droplets are sliding down and form larger droplet in the bottom of triangle (Rajaram 2015). Figures 11. and 12. are describing different water droplet creations mechanism.

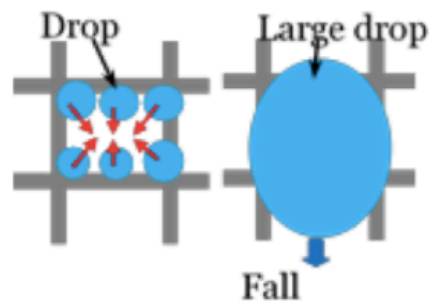

Figure 11. Water droplets formation in rectangular mesh.

Source: Rajaram 2015

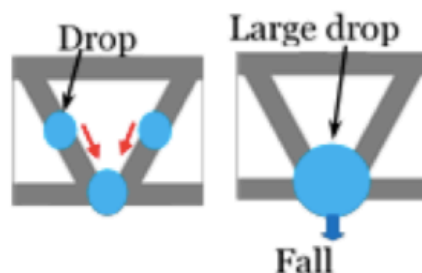

Figure 12. Water droplets formation in triangular Raschel mesh.

Source: Rajaram 2015

The main difference in usage and switching from rectangular shape to triangular is that when the larger droplet on rectangular mesh is formed, the whole pore is filled and wind flow through mesh is reduced. This process increases SC, when all pores are filled the SC is almost 100 % and this condition is similar to a solid plate without pores, when aerodynamic efficiency is at the lowest point of 9 % and smaller water droplets formed on the side of fibers are easily blown away by the wind force. The model of mesh (Raschel mesh) doesn't have these two problems due to the design and usage of rectangular fiber with triangular pattern. Tiny water droplets are usually formed in a front side of fiber, which is directly in contact with wind, only few drops were seen on the back side of fiber (Rajaram 2015). Practical comparison of a rectangular and triangular mesh pattern in water collection efficiency is offered in section 4.2.6.4

#### 4.2.6.3. Rupture of a mesh

Many materials are used for water collection, but almost any study has monitored a pressure force effect on a mesh. It is clear, that different meshes are able to handle various pressure forces. In the study from Holmes et al. (2014) it is described the pressure effect on Raschel mesh as an anisotropic material, meaning that mesh is being stretched into two different directions and both directions have various range of stiffness, when the limit is exceeded, the mesh is broken. In along direction the mesh is more flexible, so rupture point was set at 17,500 N/m<sup>2</sup> and in across direction rupture point was set at lower value of 900 N/m<sup>2</sup>. Higher pressure force can lead to two scenarios: under rupture point the force can deform permanently collecting mesh and above the rupture point the force can cause breakage. From this statement it is predicted that in case of breakage of the mesh the rupture will occur at across direction.

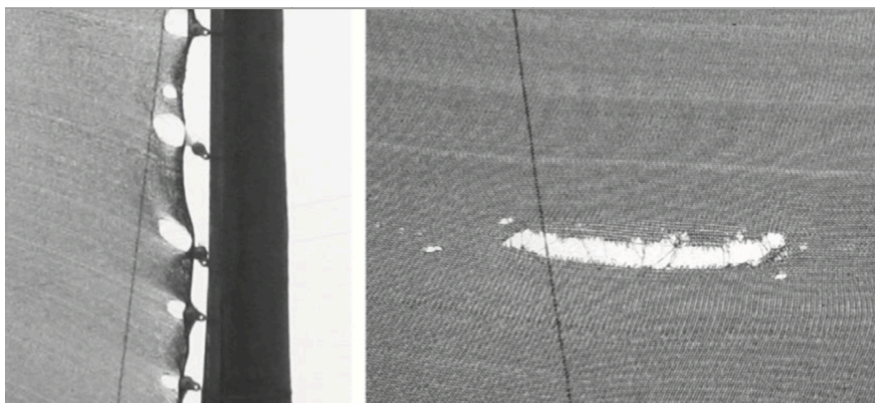

Figure 13. Examples of across breakage on Raschel mesh: on the left side is shown an area near the frame and on the right is the middle part of a mesh.

Source: Holmes et al. 2014

In the abovementioned study it is also described the process of sagging, i.e. the situation when the strong wind blows towards the mesh and creates parabolic shape, in this case the outcome is deformation not the breakage. The study

indicated that sagging could improve collection efficiency, due to increasing drag coefficient, which is in direct dependency with collection efficiency. However, this statement wasn't proved by any experiment. The whole sector of wind pressure on mesh is not completely researched and needs more information and examination (Holmes et al. 2014).

#### 4.2.6.4. Comparison of different types of meshes

In different places, various factors are present, for example wind direction, wind speed, size of droplets and volume of water content. For specific condition are more suitable different types of meshes with different type of material and pattern of the mesh.

According to one of the newest study from Fernandez et al. (2018) Raschel mesh is the most used type till now. FogHa-Tin and MIT-14 are two new and most promising and interesting meshes and deserve evaluation. These three meshes were put under test to compare collection efficiency.

Research took part in USA in state California. Experiment was collecting data from four coastal areas with different vegetation, elevation and distance from the ocean. In general, more collection areas are providing better objectivity of an outcome of experiment. All of the study sites were located on the west coast, namely Peperwood Preserve with 400 m above sea level and 40 km far away from the ocean; second collection site called Montara with 8 m above the sea level and 20 m from the ocean; Fritzsche Field with 40 m above the sea level and 5 km from the ocean and Glen Deven Ranch with 300 m above the sea level and 1 km from the ocean. In each site all meshes were tested, they were placed on SFC of standard area 1 m<sup>2</sup> during three fog seasons from 2014 till 2016. Fog season is usually from May till the middle of October. Data were summarized during the summertime fog season to avoid intercepting increased rainfall activity connected with wet season (Fernandez et al. 2018).

#### Rashel mesh

Description of Raschel mesh was provided in section 4.2.6.1. During this study was used double layered Raschel mesh.

#### MIT-14

Is basically improved stainless steel wire mesh, modernized by hydrophobic coating to increase water collection efficiency. This substance is called POSS-PEMA and was developed by Cohen research group at the Massachusetts Institute of Technology (MIT), Department of Chemical Engineering (Park et al. 2013). The parameters of stainless steel mesh are 0.02 mm wire diameter with a hole spacing of 0.051" resulting in 196 (14 by 14) holes per square inch and a shade coefficient of 49 % (Fernandez et al. 2018).

## FogHa-Tin

This type, was constructed by the Institute of Textile Technology in Germany (Denkendorf). The FogHa-Tin textile was created with application of biomimicry that is increasing water collection efficiency. Pattern contains an elaborate interweaving of approximately 0.13 mm diameter polypropylene filament into a flexible 1.5 cm thick structure with interleaved sets of embedded hexagonal patterns. FogHa-Tin could be used in two positions, which were also engaged in the study. Rotated and non-rotated position was tried. Rotation is 90 degrees. (Fernandez et al. 2018). All fog collectors were aligned to face the direction of the prevailing wind, determined from historical meteorological observations at each location (Fernandez et al. 2018). Figures 14. A, B and C are offering closer look on a structure of meshes.

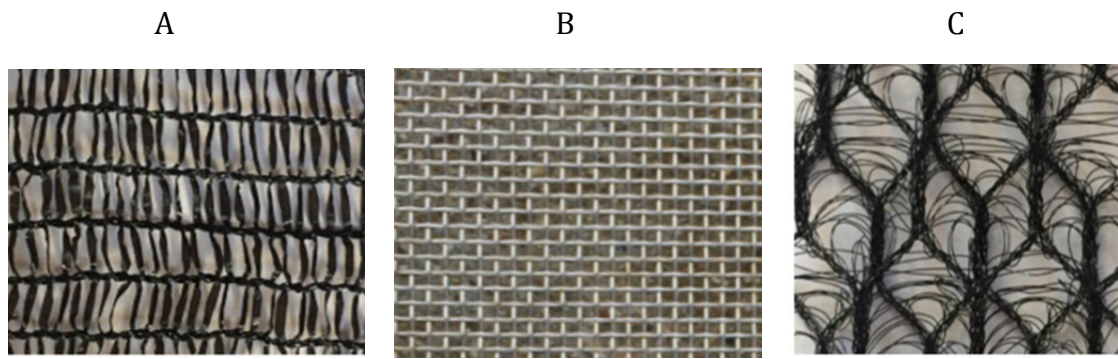

Figure 14. (A) Raschel mesh pattern. (B) pattern MIT-14 mesh pattern. (C) FogHa-Tin mesh pattern.

Source: Fernandez et al. 2018

In each site three pairs of SFC were installed. This placing next to each other could offer better comparison view. Pairs were chosen like: Raschel and MIT-14, Raschel and rotated FogHa- Tin and rotated FogHa-Tin and regular (non-rotated) FogHa-Tin (Fernandez et al. 2018)

### Raschel mesh compared to MIT 14 mesh

Data for comparison of double layer mesh with 35 % shade coefficient and MIT-14 had been collected only from three of four areas (Glen Deven, Fritzsche Field and Pepperwood Preserve) during the time period of 2014-2015. Raschel mesh has been more effective in smaller wind velocity; exactly in a range of wind speed from 1-2 m per second, but in any other different wind range MIT-14 was found to be more effective. This outcome was surprising, because 1 mm width flat fibre with combination of 35 % shade coefficient was considered as better option than 0.5 diameter steel wire with shade coefficient 49 %. Reason for that seems to be increasing wind speed. Rigidity of metallic wire seems to work better in higher wind speed, because it needs higher wind speed to help overcoming obstacles to keep ideal wind flow through the mesh and promote drainage, thus enhancing its relative performance at higher wind speeds. One of the reasons of better working

of Raschel mesh in lower wind speed is its flexibility, which allows easier penetration of a mesh. Final outcome was 46 L for MIT-14 and 41 L for Raschel mesh in period from 2014-2015. This makes MIT-14 about 12 % more efficient than Raschel mesh. Another strong argument for MIT-14 is that there are noticed cases, when MIT-14 captured water and Raschel mesh didn't (Fernandez et al. 2018)

#### Raschel mesh compared to rotated FogHa-Tin mesh

Pairs of these meshes were installed in all four locations and for the whole period (2014-2016). That obviously means that the total collected volume of water in case of Raschel mesh was higher, than in researched Raschel mesh versus MIT-14. Outcome of a comparison between Rachel mesh and rotated FogHa-Tin was that rotated FogHa-Tin collected 82 L per measured period and Rachel mesh 77 L, which makes rotated FogHa-Tin 7 % more efficient. Raschel mesh had still the best collection efficiency in the range from 1-2 m per second speed and Rotated FogHa-Tin had better efficiency in all others range of wind speed, as similar to MIT-14 (Fernandez et al. 2018).

#### Rotated FogHa-Tin mesh compared to non-rotated FogHa-Tin mesh

While testing rotated versus non-rotated FogHa-Tin, the results from observations in California region indicated low presence of fast blowing wind. Most of the fog events were captured with velocity of 1-2 m per second. Change appeared in May and July 2016. Only these two months this study provided the samples and only from Fritzsche Field. Explanation, why more samples weren't collected is not given in the study. During these two months, most of the samples were collected with wind speed in a range of 7-9 m per second. In that conditions non-rotated mesh seem to be slightly more effective; with higher effectiveness of 4 %. It is interesting that in variations of wind speed these two meshes had the most similar outcomes, however, non-rotated mesh is still considered as a better option according to the study (Fernandez et al. 2018).

Although, it is hard to say which mesh is the best, because some samples were missing. Not all meshes were put in same collection time and area as well as comparison of MIT-14 and non-rotated and rotated FogHa-Tin are not given in this study. Still as the best mesh for collection is estimated to be MIT-14 due to its highest collection efficiency. Nevertheless, there are some important facts such as price of material that is used and its weight (Fernandez et al. 2018). As the main aim of the harvesting technology is to provide water in poor areas, so the material for collectors' mesh should be cheap, accessible and light (Wahab & Lea 2008; Leboeuf & De La Jara 2014; Klemm et al. 2012). Stainless steel wire could cost a few hundred dollars per m<sup>2</sup>, which is definitely not adequate. Specially, if we consider MIT-14 as a mesh for LFC, where typically used area is 40 m<sup>2</sup> or 48 m<sup>2</sup>, the total price would be critically high and also construction would be difficult due to big weight of steel wire. On the other hand, Raschel mesh costs only few pennies per m<sup>2</sup> and it serves its purpose to be low-cost and light material. As it was found in the study of Fernandez et al. (2018) that collection efficiency of FogHa-Tin mesh

is higher than the efficiency of Raschel mesh, it could be observed like a middle way in future progress of fog harvesting technology. FogHa-Tin mesh is about 15 times more expensive in comparison with Raschel mesh, but still it is cheaper than steel wire (Fernandez et al. 2018). The study from Qadir et al. (2018) has stated different and higher price. According to this study, m<sup>2</sup> of two-dimensional Raschel mesh costs from 25-50 dollars. This huge difference in prices could be caused by uneven value of money or just due to accessibility of certain materials in different areas. For example in Morocco, during Dar Si Hmad's Fog water Project, the cost of the whole 40 m<sup>2</sup> mesh was 200 dollars. That's one-fifth from lowest estimated price, which was stated in first suggestion. Taking into account the cost of 25-50 dollars the deduced price of LFC with an area of 40 m<sup>2</sup> is 1,200-2,400 dollars. Variation in prices is mostly caused by some other additional attachment, which could or couldn't be present (Qadir et al. 2018).

#### 4.3. Use of fog collecting systems

##### 4.3.1. Introduction of fog collecting systems

Developing countries are still the primary place, where collection systems are applied. Almost every time, starter pack of money is needed. Money could be provided by, some implementing partner, such as government institution or community-based unit, a non-governmental organization or a suitable combination of them. The fact that is coming out from this study of Qadir et al. (2018), which stated that efficiency and long term usage of water collecting system is connected with feeling of ownership, when local people take implementation of project as their responsibility, they start to take project more seriously and put more effort in it, which leads to longer and more prosper attitude (Qadir et al. 2018). It is similar method, which is used in other developing projects. This method is called cash for work (CFW). It is often applied after some natural disaster like hurricane, floods or tsunami. This method was practiced for example after floods in Bangladesh or in the countries with unstable government like Afghanistan or Democratic Republic of Congo. The aim of the method is simple, to create bond with the project and local people. Difference is that only knowledge is passed to impaction area, work has to be done by local people. By this process local people become more attached and interested in project and sustainable future usage is more possible (Doocy et al. 2006).

##### 4.3.2. Quality of fog collected water

Although in the majority of studies (Qadir et al. 2018; Morichi et al. 2018; Wahab & Lea 2008) fog water is describes as potable, its contamination is possible and that is important to know about. Fog water could be contaminated in two ways: from the air conditions in capturing area and by pollutants mostly created by anthropogenic activities. For formation process, which is taking part in relatively low area above the ground, it may also lead to contamination from the ground.



Pieces of dust or sand can be blown by wind and transported to collection gutter or contaminate mesh. But not only human activities are playing role in contamination; animal species can also contribute to pollution. Things like birds' excrements, insects' excrements or the whole insects' dead bodies can foul capturing mesh or directly water content. Well known pollutants from anthropogenic activities are calcium, sodium, chloride and bicarbonate. Nevertheless it is estimated that most of the fog water for drinking purpose is meeting WHO's (World's Health Organization) standards. Mostly occurred reasons when water doesn't meet WHO's standards are due to the presence of iron and nitrate content. And, it is also estimated that rainwater has lower concentration of soluble particles than fog collected water (Domen et al. 2014). In the study from Abdul-Wahab et al. (2007) it is described that also surroundings have important impact on water quality. For example, collection system placed near industrial areas tends to have higher concentration of total dissolved solids (TDS). Or other case, when water captured by system located in rural area of France was diagnosed with higher concentration of nitrate, because farmers have been using excessive amount of nitrate as a fertilizer; also lower pH was discovered there.

#### 4.3.3. Fog collected water in agriculture

Interesting method is used in protecting vegetation. Combination of protecting and irrigating of vegetation was conducted. Protection meshes and cages were made from water collecting material, which contribute to irrigation system (Morichi et al. 2018).

The study from Baguskas et al. (2018) was focused on fog contribution to growing strawberries in Californian coastal region. First fact, that has been estimated is, that in coastal areas there is more frequent occurrence of fog events than in in-land areas. Also this study has proved that during fog events the plants are showing better results in the whole scale. Plants during the fog didn't lose that much water within photosynthesis resulting in higher water resources for plant. As the main outcome it was considered that fog water is a good contribution to process of growing strawberries and a possibility of reducing amount of irrigated water used for crops. Thus, the owner could save part of expenses.

What is important to remind is that fog collectors are not used for intercepting water for irrigation, only by the plants, themselves. And I haven't found any article showing fog water collectors as a main source of water for large-scale agriculture. According to my opinion, fog collection systems are not contributing to irrigation in intense agriculture, because crops are able to intercept enough water, but they could be used as additional source (Baguskas et al. 2018). In the study from Klemm et al. (2012) is documented information about growing *Aloe vera* from fog harvested water; it is also estimated that this project was only small scale size. Another project was focused on reforestation in Tenerife, where harvested water was used for growing endemic specie, laurisilva vegetation.

#### 4.3.4. Contribution of fog collecting systems to community

Now, we are not going to talk about collection efficiency or how much water preciously fog collectors can intercept. Improvement of social relationships due to use of fog collectors, may sounds strangely, but it is true. Results from Moroccan NGO, Dar Si Hmad, are pointing out the fact that after successful implementation of collecting system in Atlas mountain region, where women are responsible for delivering water home, preparing of food and take care of their family from nutrition point of view. Provided water system helped woman to fulfill demand for water and they don't have to pass long distances to get water, because collection system is placed in a near area to the community. Another, maybe more important fact is that lots of young woman are not able to study, because of the time that they are spending on delivering water to their homes. This new water source is not only giving more opportunities to women, but also decreasing gender differences in developing countries. In many developing countries there is still strong model of family, where woman is responsible for nutrition and raising children and man has to provide family with money. This effect of breaking gender barriers should be common in other places the same as in Morocco region (Morichi et al. 2018).

Based on opinion from Rosato et al. (2010) enlarging gender equality and getting out from typical pattern will help to successful implementation of a project. As it was mentioned before, women are responsible for obtaining water, which is the main purpose of collection system, so supervisors of a project felt responsibility to invite local woman from West highland of Guatemala to work on a project in the same range as men; meaning that they were involved in building, maintained chores and management decisions. As a survey stated, all woman in a community felt more valuable, resulting in creation of better financial, social and human capital of the community and also improving health situation, education, i.e. the bases of the community livelihood (Qadir et al. 2018).

#### 4.3.5. Implemented projects in developing countries outside MENA

In the year 1987 first larger project was implemented. The main idea of the project was to connect a number of LFC to one operational system. From 1987 till 1991 fifty LFG with area of 48 m<sup>2</sup> each were installed and put into operation in Chilean region Coquimbo, area El Tofo. As a material for screen was chosen double layer polypropylene mesh with water yield 3 L/m<sup>2</sup> per day as an average in drought season and the highest yield in wet season reached the values about 85,000 L per day from whole collection system. During this time thanks to an amount of collected water needs to import water to Coquimbo village decreased, which also lead to reduction of the price per 1 m<sup>3</sup> of potable water. Before function of the system, 1 m<sup>3</sup> of potable water costs 7.25 \$, after introduction of the system the cost of 1 m<sup>3</sup> dropped to 1.87 \$(Wahab & Lea 2008). In early 90s, the project got green light for enlargement. The main aim was to create a supply of freshwater to Chungungo costal community, where about 100 families lived in that time (Wahab & Lea 2008; Leboeuf & De La Jara 2014). Enlargement was constituted for 48 more LFCs of the same size, i.e. the system with total number of 98 LFCs. New

system was able to deliver in average extra 15,000 L of potable water per day for the time period of ten years. During the 10 years, when the system was functional, three drought years were recorded. Average water yield was 7,200 L per day. After ten years of function, the community wasn't able to take care of maintenance anymore and deal with thieves, which were stealing and selling the material from fog collectors (Leboeuf & De La Jara 2014). During the time a lot of new project was started.

In Ecuadorian mountain region called Pachamama Grande were found ideal condition and high collection efficiency reaching up to 12 L/m<sup>2</sup> per day. The large-scale project started in 1995 till 1997 with 40 LFCs. Project was founded by NGO and eventually handed over to local community. Unfortunately, with the same outcome as in El Tofo, i.e locals weren't able to keep collecting system in use and good condition.

Another big, more successful project was conducted in 2006 in Guatemalan village of Tojquia. The village is built in western mountain region at 3,330 m above the sea level. In these rough conditions was constructed the system of 35 LFCs with total yield of 6,300 L per day for whole system. In winter dry seasons, which could be in period of 4-6 months. In wet season, collection rate was increased due to extra rainfalls. Problematic factor in the high altitudes is connected with strong winds and pressure on the mesh of fog collector. Local people have to be trained in maintenance and repair works. System is functional from the year 2006 to the last mentioned information in 12 of May 2011, when the system was still operating. Interesting aspect of this project is that women hard labour was decreased, because it is very often women responsibility to deliver water for the household (Klemm et al. 2012).

#### 4.3.6. Fog harvesting practices in MENA countries

All countries from MENA region are sharing the same problem related to the limited water resources. Countries with documented focus on implementation of fog collecting are Oman, Saudi Arabia, Iran, Morocco Egypt. In this region fog harvesting is aiming not only to become a solution of water shortage, but also serve as a helping technique to decrease water demand in the areas with obstacles in obtaining fresh water (Algarni 2018).

##### Fog harvesting in Oman

The project has started here mostly because of increased fog events during the summer between June and September. The Oman region, Dhofar, is well known for fog events in the summer. Fog events are so strong, that the effect of fog occurrence has its own name. This effect is called Al-Khareef. Certain communities live in an altitude of 1,000 meters above sea level and they are not connected to ground water resources and water has to be delivered to the location by trucks, which is an expensive way of supplying. Local fog collectors seem to be as a good alternative option. Project was conducted on an area of one house in July to

September 2005. Three LFCs were erected with different collecting areas and meshes: first (1) with aluminum single layered mesh with an area of 16.8 m<sup>2</sup>; second (2) with a single layered green shade mesh with 36 m<sup>2</sup> area; third (3) with aluminum triple layered mesh with 36 m<sup>2</sup>. Fog collector (1) had the best collection efficiency, but due to its size, it collected the lowest volume of water (18,438.68 L per collecting period). LFC (2) from obtained data has better rates and collected 35,380.8 L per collecting period. LFC (3) had collected 30.816 L per collecting period. Obstacles in fog collecting in Dhofar are low fog events, where these three months are the only possibility for collecting process. Still an evaluation of the project is that collected water contribution can be used for reforestation purposes to tree seedlings and irrigation for community use (Wahab et al. 2007).

### Fog harvesting in Saudi Arabia

Few studies have been conducted in Saudi Arabia, resulting in evaluation of fog potential in certain days of a month. Latest study from Algarni (2018) brings clear results in deciding whether fog collectors can be contributive source in mountain Southwest region (Asir) or not. In this concrete area local people have serious difficulties in obtaining fresh water and fog water seems as a solution to deliver supporting volume of water for agricultural use. Asir's high altitude of 2,000 m above the sea level is disadvantage and also advantage, because orographic fog contains more water and higher wind speed contributes to collection efficiency, too. Two SFCs, with collection area of 1 m<sup>2</sup> were placed besides each other to face wind flow, mostly in perpendicular way. Two types of meshes were used, first collector with double layer Raschel mesh with SC 40 % and second with single layer Raschel mesh with 35 % SC. Average collection rate was estimated during one year from January to December in 2016. Resulting in higher efficiency of double layered mesh with 6.7 L/m<sup>2</sup> per day, single layered mesh collection rate was 5.5 L/m<sup>2</sup> per day. This state is proving the declaration that double layered meshes can provide more water volume than single layered (Wahab & Lea 2008; Fernandez et al. 2018). From research was also clear that March has the most suitable collecting conditions with the biggest number of fog days, which was 21, so both collectors collected majority of water during this month. Double layered mesh average yield was 13.2 L/m<sup>2</sup> per day and single layered mesh yielded 9.2 L/m<sup>2</sup> per day. According to collected data, fog harvesting could be alternative source of water in Asir region, especially as a contribution to agricultural purposes in small scale (Algarni 2018). More information and more practical documented projects need to be done.

### Water harvesting in Iran

Only two projects have been conducted in Iran that we know about. The main of the first project was observations of conditions for future collection in Southern Khorasan province. Second project was as a literature review on fog collection in Hormozgan region. First project was inspired by Chilean fog collection, for comparison, Chilean areas where water collection took a part was place with 200 and more foggy days. In contrast, Khorasan area has maximum of 41 foggy days. This study was also considering days, when fog was not fully created; only level of

relative humidity of air was higher, near to 69 % (Davtalab et al. 2013). As it was mentioned before fog cloud relative air humidity is between 90-95 % (Pospíšilová 2012). Number of days with relative air humidity near 69 % is in a range of 132-346 days. Data about wind potential were collected from 10 synoptic stations. Study has recording all data from period of 1992 till 1999. Air flows were measured under 8 different angles of impaction, with outcome that in the place, where the stations was located the highest water collection potential was 468.8 L/m<sup>2</sup> per day. This outcome is hard to believe, considering low number of foggy days and average collection stated in others studies at 1-12 L/m<sup>2</sup> per day (Qadir et al. 2018; Ghosh & Ganguly 2018). It seems, that more research or practical experiments need to be performed. It is important to remind that this study was testing theoretical wind potential (Davtalab et al. 2013).

### Water harvesting in Morocco

As the biggest water collection system can be considered the project from NGO, Dar Si Hmad. Project is located in Southwest Morocco in the anti-Atlas mountains near Sidi Ifni. At the beginning the location was searched based on the minimum necessary fog presence (Qadir et al. 2018). Measurement was done by Davis weather station on a field of barometric pressure, rainfall, humidity, temperature, wind speed and direction (Dodson & Barcgach 2015). After successful proof about presence of fog events, the team of engineers, climate and social scientists, meteorologist, technologist and also members of rural Berber communities started to work on implementation of the project (Qadier et al. 2018). This concrete area is dealing with water scarcity, mostly cause by low precipitations, which are under 150 mm/m<sup>2</sup> per year. Drought is not only the reason, why alternative source of water is needed. Research of water resources showed, that serious part of water for domestic and small-scale agriculture use is contaminated. High concentration of chemical salts, were found, including sulfates (130-210mg/L), nitrates (80-280 mg/L) and uranium and selenium. In effort to create potable water for drinking and agricultural purposes, 20 LFCs were installed with total collection area of 600 m<sup>2</sup> and one, solar electricity powered UV filtration unit. After filtration process, water is transported 7 km to reservoirs, where water is stored for further use, supplying 5 villages and 4 rural schools with total population of 500 inhabitants. Water is stored in two containers of the volume of 250 m<sup>3</sup> and 214 m<sup>3</sup>. After the installation, a measured collection efficiency was estimated to be 6,300 L per day in average, which makes 2.3 million L per year under constant weather condition. As a result of implementing this collection system, certain goals were achieved. As mentined before, big role during this project had women (Qadir et al. 2018; Dodson & Barcgach 2015).

Benefits and outcomes of the project:

- Alternative water supply from fog water content.
- Water delivered to rural houses and schools.
- Increased health condition by providing water meeting WHO standards.
- More stable livelihood, reduction of rural poverty and increasing gender equality by creating time and space for women to study.

- Increased number of animals for agricultural use (Qadir et al. 2018).

#### Water harvesting in Egypt

Fog harvesting in Egypt is in the beginning. There are still no fully operating collection systems, only one experimental project was conducted. There are places in Egypt with almost zero or zero rainfall far away from Nile river, which is the main water source for inhabitants. In an area like this, Bedwe communities are living. Although there is a very low amount of rainfall source, fog events are present. Project started due to the information from near countries about possible water harvesting. Pilot study from Yemen stated that they have found suitable conditions for fog harvesting in the mountains near Hajja city, with collection efficiency of 4.5 L/m<sup>2</sup> per day. Two experiments were conducted in North Egyptian area near Mediterranean Sea. According to collected data, from the summer period 2013-2014, relative humidity of air was in a range of 81-82 %, in time period from 23 p.m till 7 a.m. Different approach was chosen to evaluate collection technology. Instead of pointing out collection efficiency, contribution to growing peanuts was documented. Four testing LFCs with the same size of 51 m<sup>2</sup> (Harb et al. 2016). Picked dimension of used collectors is more than average dimension of LFC (Fernandez et al. 2018; Rivera & Lopez-Garcia 2014). Each LFC had different collecting mesh. Most successful mesh was, double layer polypropylene mesh with SC 70 %. Total collection efficiency for a season 2013 was 1,126 m<sup>3</sup> of fresh water and the season after, common amount of 1,144 m<sup>3</sup> of fresh water was collected. Lowest collection efficiency had single layer polypropylene mesh with SC 50 % and collection efficiency in 2013 about 880 m<sup>3</sup> of fresh water and 889 m<sup>3</sup> of fresh water in 2014. As an outcome it was stated that all collection rates accomplished the task and provide enough water to grow peanut seeds in arid soils. Even though this pilot study is considered as a good achievement, there are no further records about fog collection in Egypt (Harb et al. 2016).

## 5. Conclusion

Fog water content is contributing to vegetation and animals from the beginning of time and we have possibilities to intercept water content and use it, especially in areas without any other relevant water source, for our needs and to overcome obstacles and raise welfare of people. From summarized information it is obvious that MENA region is now under strong water threat and fog collection is one of the alternative local solution.

Water collection yield is mostly influenced by mesh material and pattern. Various meshes are designed to work in different conditions. From an environmental point of view for the most frequently used type of mesh (Raschel mesh), size of water droplets, higher volume of water content in fog cloud and lower wind velocity (no more than 2 m per second) are contributing most to the process of water collection. Raschel mesh is not optimal for application in mountain regions due to wind speed and it is not the most effective in water collection, nevertheless typically used water collecting device is 2-D passive flat large fog collector with Raschel single or double layered mesh with 30-35 % shade coefficient. It is estimated that LFC with Raschel mesh is however the best combination of acquisition price and water yield.

The most suitable area for implementing collecting systems seems to be in mountain regions. In the areas where landscape forming impedes obtaining water from the usual water resources. Orographic fog, which is present in the locations with high altitude, is connected with higher concentration of water content in cloud per m<sup>3</sup> and with higher wind velocity. The most significant aid in water management is provided to villages, communities and small fields. Future research may bring more possible applications or development of more sufficient and cheaper collecting mesh for use in mountain regions than the Raschel mesh.

Large-scale agriculture based on fog collection is not common, although there are implemented projects like growing *Aloe vera* only from intercepted water or reforestation of endemic specie (laurisilva) vegetation, or experimental growing of peanuts in Egypt. The important thing is that we can determine fog water as an alternative source of water that can increase health, education and quality of life.

## 6. Reference

- Abdul- Wahab SA, Al-Hinai H, Al-Najar KA, Al-Kalbani MS. 2007. Fog Water Harvesting: Quality of Fog Water Collected for Domestic and Agricultural Use. *Environmental engineering science* **24**:446-456.
- Abdul-Wahab SA, Al-Hinai H, Al-Kalbani MS, Al-Najar KA. 2007. Feasibility of fog water collection: a case study from Oman. *Water Supply* **56.4**:275-280.
- Abdul-Wahab SA, Vanessa L. 2008. Reviewing fog water collection worldwide and in Oman. *International Journal of Environmental Studies* **65**: 3:487-500.
- Aizari HA, Lebkiri A, Fadli M, Albaseer SS. 2017. Quality Assessment of Ground Water in Dhamar City, Yemen. *International journal of Environment* **6**:56-71.
- Al-Saidi M, Birnbaum D, Buriti R, Diek E, Hasselbring C, Jimenez A, Woinowski D. 2016. Water Resources Vulnerability Assessment of MENA Countries Considering Energy and Virtual Water Interactions. *Procedia Engineering* **145**:900-9007.
- Algarni S. 2018. Assasment of fog collection as a sustainable water resource in the southwest of the kingdom of Saudi Arabia. *Water and Environment*. **00**:1-9.
- Aljanabi AA, Mays LW, Fox P. 2018. Application of an Optimization Model for Assessing the Performance of Water Appropriation in Iraq. *Environment and Natural Resources Research* **8**:105-118.
- Aly AA, Kishk FM, Gaber HM, Al-Omran AM. 2016. Long-term detection and hydrochemistry of groundwater resources in Egypt: Case study of Siwa Oasis. *Saudi Society of Agricultural Sciences* **15**:67-74.
- Andrews HG, Eccles EA, Schofield WCE, Badyal JPS. 2011. Three-Dimensional Hierarchical Structures for Fog Harvesting. *Langmuir* **27**:3798-3802.
- Aqeil H, Tindall J, Moran E. 2012. Water security and interconnected challenges in Libya. *Tinmore Institute* **8**:1-20.
- Baguskas SA, Clemesha RES, Loik ME. 2018. Coastal low cloudiness and fog enhance crop water use efficiency in a California agricultural system. *Agricultural and Forest Meteorology* **252**:109-120.
- Brown A, Matlock M. 2011. Review of water scarcity indices and methodologies. [Ph.D Thesis]. University of Arkansas. Arkansas.
- Davtalab R, Salamat A, Oji R. 2013. Water harvesting from fog and air humidity in the warm and coastal region in the southe of Iran. *Irrigation and Drainage* **62**:281-288.



de Fraiture C, Molden D, Wichelns D. 2010. Investing in water for food, ecosystems, and livelihoods: An overview of the comprehensive assessment of water management in agriculture. *Agricultural Water Management* **97**:495-501.

Distefano T, Kelly S. 2017. Are we in deep water? Water scarcity and its limits to economic growth. *Ecological Economics* **142**:130-147.

Dodson LL, Bargach J. 2015. Harvesting Fresh Water from Fog in Rural Morocco: Research and Impact Dar Si Hmad's Fogwater Project in Aït Baamrane **107**:186-193.

Domen JK, Stringfellow WT, Camarillo MK, Gulati S. 2014. Fog water as an alternative and sustainable water resource. *Clean Technology and Environmental Policy* **16**:235-249.

Donatelli M, Srivastava AM, Duveiller G, Niemeyer S, Fumagalli D. 2015. Climate change impact and potential adaptation strategies under alternate realizations of climate scenarios for three major crops in Europe. *Environmental Research Letters* **10**:7pp.

Doocy S, Gabriel M, Collins S, Robinson C, Stevenson P. 2006. Implementing cash for work programmes in post-tsunami Aceh: experiences and lesson learned. Blackwell Publishing **3**:227-296.

El Kharraz JE, El-Sadek A, Ghaffour N, Mino E. 2012. Water scarcity and drought in WANA countries. *Procedia Engineering* **33**:14-29.

Estrela MJ, Valiente JA, Corell D, Millán MM. 2008. Fog collection in the western Mediterranean basin (Valencia region, Spain). *Atmospheric research* **89**:324-337.

Fernandez DM, Kleingartner J, Oliphant A, Bowman M, Torregrosa A, Weiss-Penzias PS, Zhang BJ, Sorensen D, Cohen RE, McKinley GH. 2018. Fog Water Collection Effectiveness: Mesh Intercomparisons. *Aerosol and Air Quality Research* **18**: 270-283.

Fisher DT, Still CHJ. 2007. Evaluating patterns of fog water deposition and isotopic composition on the California Channel Island. *Water Resources Research* **43**:25-31.

Fischer DT, Still CJ. 2007. Evaluating patterns of fog water deposition and isotopic composition on the California Channel Islands. *Water Resources Research* **43**:13 pp.

Garrote L, Granados A, Iglesias A, Cuesta JA, Fernández-Delgado C, Vilas C, Drake P. 2016. Strategies to reduce water stress in Euro-Mediterranean river basins. *Science of The Total Environment* **534**:997-1009.

Ghosh R, Ganguly R. 2017. Harvesting Water from Natural and Industrial Fogs- Opportunities and Challenges. *Applications Paradigms of Droplet and Spray Transport: Paradigms and Applications* 23:237-266.

Gleick PH. 2014. Water, Drought, Climate Change, and Conflict in Syria. *Weather, Climate, and Society* 6:331-340.

Gonzales-Ortegón E, Baldó F, Arias A, Cuesta JA, Fernández-Delgado C, Vilas C, Drake P. 2015. Freshwater scarcity effects on the aquatic macrofauna of a European Mediterranean-climate. *Science of The Total Environment* 503-504:213-221.

Gosling SN, Arnell NW. 2013. A global assessment of the impact of climate change on water scarcity. *Climatic Change* 134:371-385.

Haddeland I, Heinke J, Biemans H, Eisner S, Flörke M, Hanasaki N, Konzmann M, Ludwig F, Masaki Y, Schewe J, Stacke T, Tessler ZD, Wada Y, Wisser D. 2014. Global water resources affected by human interventions and climate change. *PNAS* 9:3251-3251.

Harb OM, Salem MS, Abd EL-Hay GH, Makled KM, Flörke M, Hanasaki N, Konzmann M, Ludwig F, Masaki Y, Schewe J, Stacke T, Tessler ZD, Wada Y, Wisser D. 2016. Fog water harvesting providing stability for small Bedwe communities lives in North cost of Egypt. *Anal of Agriculture Sciences* 61:105-110.

Holmes R, de Dios Rivera J, de la Jara E. 2014. Large fog collectors: New strategies for collection efficiency and structural response to wind pressure. *Atmospheric Research* 151:236-249.

Jenkins, Brian Michael. *The Dynamics of Syria's Civil War*. 2014. CA: RAND Corporation. Santa Monica.

Kahime K, Salem AB, El Hidan A, Messouli M, Chakhchar A. 2018. Vulnerability and adaptation strategies to climate change on water resources and agriculture in Morocco: Focus on Marrakech-Tensift-Al Haouz region. *Internal Journal of Agriculture and Environment Research* 04:58-77.

Klemm O, Schemenauer RS, Lummerich A, Cereceda P, Marzol V, Corell D, van Heerden J, Reinhard D, Gherezghiher T, Olivier J, Osses P, Sarsour J, Frost E, Estrela Fessehayé GM, Valiente JA. 2012. Fog as a Fresh-Water Resource: Overview and Perspectives. *AMBIO* 41:221-234.

Kummu M, Ward PJ, de Moel H, Varis O. 2010. Is physical water scarcity a new phenomenon? Global assessment of water shortage over the last two millennia. *Environmental Research Letters* 5: 1-10.

LeBoeuf R, De la Jara E. 2014. Quantitative goals for large-scale fog collection projects as a sustainable freshwater resource in northern Chile, *Water International* **39:4**:431-450

Mohanty SK, Nandha M, Turkistani AQ, Alaitani MY. 2011. Oil price movements and stock market returns: Evidence from Gulf Cooperation Council (GCC) countries *22*:42-55.

Morichi G, Calixto LB, Zanelli A. 2018. Novel Applications for Fog Water Harvesting. *Journal of Geosciences and Environment Protection* **6**:26-36.

Navarro-Ortega A, Bellin A, Burek Peter, Cassiani G, Dolédec S, Ginebreda A. 2014. Managing the effect of multiple stressors on aquatic ecosystems under water scarcity. The GLOBAQUA project. *Science of The Total Environment* **503-504**:3-9.

Pospíšilová P. 2012. Možnosti modelování mlhy v GIS [MSc. Thesis]. Univerzita Palackého v Olomouci. Olomouc.

Qadir M, Jiménez G, Farnum R, Dodson L, Smakhtin V, Jimenez A, Woinowski D. 2018. Fog Water Collection: Challenges beyond Technology. *Water* **4**:362-372.

Rajaram M, 2015. Enhancement of fog-collection efficiency of Raschel mesh using surface coating and geometric changes. [Ms. Thesis]. University of Texas in Arlington. Arlington.

Regalado CM, Ritter A, Lummerich A, Cereceda P, Marzol V, Corell D, van Heerden J, Reinhard D, Gherezghiher T, Olivier J, Osses P, Sarsour J, Frost E, Estrela MJ, Valiente JA, Fessehayé GM. 2016. The design of an optimal fog water collector: A theoretical analysis. *Atmospheric Research* **178-179**:45-54.

Rosato M, Rojas F, Schemenauer RS. 2010. Not just beneficiaries: Fostering participation and local management capacity in the Tojquia fog-collection project. *Fogquest* **3**:248-251.

Shewe J, Wada Y, Wisser D, Eisner S, Gerten D, Haddeland I, Hanasaki N. 2013. Multimodel projections and uncertainties water demand under climate change. *Geophysical Research Letters* **40**:4626-4632.

Schlosser CA, Strzepek K, Gao X, Fant C, Blanc É, Paltsev S, Jacoby H, Reilly J, Gueneau A. 2014. The future of global water stress: An integrated assessment. *Earths Future* **2**:341-361.

Scholl M, Eugster W, Burkard R. 2010. Understanding the role of fog in forest hydrology: stable isotopes as tools for determining input and partitioning of cloud water in montane forests. *Hydrological Process* **25**:228-241.

Siddiqi A, Anadon LD. 2011. The water-energy nexus in Middle East and North Africa. *Energy Policy* **38**:4529-4540.

Soto-García M, Martínez-Alvarez V, García-Bastida PA, Alcon F, Martin-Gorriz B, Vilas C, Drake P. 2013. Effect of water scarcity and modernisation on the performance of irrigation districts in south-eastern Spain. *Agricultural Water Management* **124**:11-19.

Sowers J, Vengosh A, Weinthal E. 2010. Climate change, water resources, and the politics of adaptation in the Middle East and North Africa. *Climatic Change* **104**:599-627.

Tamea S, Carr JA, Laio F, Ridolfi L. 2014. Drivers of the virtual water trade. 2013. *Water Resources Research* **50**: 103-112.

Vörösmarty CJ, Green P, Salisbury J, Lammers LB. 2000. Global Water Resources: Vulnerability from Climate Change and Population Growth. *Science* **289**:284-288.

Xu T, Lin Y, Zhang M, Shi W, Zheng Y. 2016. High-Efficiency Fog Collector: Water Unidirectional Transport on Heterogeneous Rough Conical Wires. *ACS Publications*: **10**:10681-10688.