



VYSOKÉ UČENÍ TECHNICKÉ V BRNĚ

BRNO UNIVERSITY OF TECHNOLOGY

FAKULTA ELEKTROTECHNIKY A KOMUNIKAČNÍCH TECHNOLOGIÍ

FACULTY OF ELECTRICAL ENGINEERING AND COMMUNICATION

ÚSTAV TELEKOMUNIKACÍ

DEPARTMENT OF TELECOMMUNICATIONS

IMPLEMENTACE SLUŽBY VOLTE DO SÍTÍ EPS- IMS

VOLTE SERVICE IMPLEMENTATION IN EPS-IMS NETWORKS

DIPLOMOVÁ PRÁCE

MASTER'S THESIS

AUTOR PRÁCE

AUTHOR

Bc. Mikhail Baev

VEDOUCÍ PRÁCE

SUPERVISOR

doc. Ing. Vít Novotný, Ph.D.

BRNO 2016

ANOTACE

Diplomová práce popisuje VoLTE službu, vývoj a nasazení LTE (zaváděcí fázi, skutečný LTE stav a výhledy do budoucna atd.), EPC-IMS architekturu (popis funkce uzlu, rozhraní atd.) Komunikace mezi uzly a funkce, rozhraní a protokoly jsou používány v průběhu signalizace (SIP SDP) a datový tok (RTCP RTP). Práce stručně popisuje základní toky hovorů, typy nosičů (GBR and N-GBR), a to vytvoření / mazání nosičů během komunikace. Další část diplomové práce o implementaci volte, instalace a konfigurace IMS. Závěrečná část diplomové práce popisuje zkoušky sítě a, analýzu protokolu.

KLÍČOVÁ SLOVA

VoLTE, Call flow, IMS, EPC, CSCF, HSS, mobile network, SIP, SDP, RTCP, RTP

ABSTRACT

The master's thesis describes VoLTE service, LTE evolution and deployment (deployment phases, actual LTE state and future perspectives etc.), EPC-IMS architecture (functional node description, interfaces etc.). Communications between nodes and functions, interfaces and protocols which are used during signaling (SIP-SDP) and data flow (RTCP RTP). Thesis briefly describe basic call flows, bearers types (GBR and N-GBR) and their establishment/delete during communication. The next part of master's thesis is about VoLTE implementation solutions, IMS installation and configuration. The final part of master's thesis describes the network and protocols tests, analyzes.

KEYWORDS

VoLTE, Call flow, IMS, EPC, CSCF, HSS, mobile network, SIP, SDP, RTCP, RTP

Baev, M. *Volte service implementation in EPC-IMS networks: diploma thesis*. Brno: FEKT VUT v Brně, 2016. 56 pages, 3 appendices. Supervisor doc. Ing. Vít Novotný, Ph.D.

Prohlášení

Prohlašuji, že svou diplomovou práci na téma „IMPLEMENTACE SLUŽBY VOLTE DO SÍTÍ EPS-IMS“ jsem vypracoval samostatně pod vedením vedoucího diplomové práce a s použitím odborné literatury a dalších informačních zdrojů, které jsou všechny citovány v práci a uvedeny v seznamu literatury na konci práce.

Jako autor uvedené diplomové práce dále prohlašuji, že v souvislosti s vytvořením této diplomové práce jsem neporušil autorská práva třetích osob, zejména jsem nezasáhl nedovoleným způsobem do cizích autorských práv osobnostních a/nebo majetkových a jsem si plně vědom následků porušení ustanovení § 11 a následujících zákona č. 121/2000 Sb., o právu autorském, o právech souvisejících s právem autorským a o změně některých zákonů (autorský zákon), ve znění pozdějších předpisů, včetně možných trestněprávních důsledků vyplývajících z ustanovení části druhé, hlavy VI. díl 4 Trestního zákoníku č. 40/2009 Sb.

V Brně dne

podpis autora

Poděkování

Děkuji vedoucímu práce doc. Ing. Vítu Novotnému, Ph.D za velmi užitečnou metodickou pomoc a cenné rady při zpracování diplomové práce.

V Brně dne

.....
podpis autora

The research described in this diploma thesis has been done in laboratories supported by Sensor, Information and Communication Systems Research Centre (SIX) project; registration number CZ.1.05/2.1.00/03.0072 Operational Program Research and Development for Innovation (operační program Výzkum a vývoj pro inovace).

Contents

| | | |
|-------|---|----|
| 1 | Introduction..... | 9 |
| 2 | LTE..... | 10 |
| 2.1 | Evolution and deployment..... | 10 |
| 2.2 | LTE characteristics and goals..... | 11 |
| 3 | VoLTE architecture | 12 |
| 3.1 | UE | 12 |
| 3.2 | Evolved Universal Terrestrial Access Network – E-UTRAN architecture | 12 |
| 3.3 | Evolved packet core (EPC) architecture | 13 |
| 3.3.1 | Functions and nodes | 13 |
| 3.3.2 | Interfaces | 14 |
| 3.3.3 | Protocols | 15 |
| 3.4 | IP multimedia subsystem (IMS) architecture..... | 16 |
| 3.4.1 | Functions..... | 16 |
| 3.4.2 | IMS interfaces description..... | 19 |
| 3.4.3 | IMS protocols | 22 |
| 4 | VoLTE service requirements | 25 |
| 4.1 | Adaptive Multi-Rate (AMR) Speech Codec | 25 |
| 4.2 | Robust Header Compression..... | 25 |
| 4.3 | LTE Radio Capabilities | 25 |
| 4.4 | RLC configurations..... | 27 |
| 4.5 | Guaranteed bit rate (GBR) bearer..... | 27 |
| 4.6 | P-CSCF Discovery | 28 |
| 4.7 | Addressing..... | 29 |
| 4.8 | Handovers | 29 |
| 5 | The basic call flows scenarios | 30 |
| 5.1 | Attachment and IMS Registration..... | 30 |
| 5.1.1 | Default Bearer establishment for attach to IMS | 30 |
| 5.1.2 | IMS registration | 33 |
| 5.2 | Basic VoLTE UE to VoLTE UE Voice Call Establishment | 36 |
| 5.2.1 | Originating Side..... | 36 |
| 5.2.2 | Terminating Side | 40 |
| 5.3 | Basic VoLTE UE to VoLTE UE Voice Call Clearing..... | 43 |

| | | |
|-------|--|----|
| 5.3.1 | Initiated side | 43 |
| 5.3.2 | Received side | 44 |
| 6 | Tests on LTE network..... | 46 |
| 6.1 | EPC attach UE – eNodeB - MME | 46 |
| 7 | VoLTE implementation analyze and solution..... | 48 |
| 7.1 | IMS install | 48 |
| 8 | Conclusion | 50 |
| 9 | Literature | 51 |
| 10 | Abbreviations..... | 53 |

1 Introduction

Modern networks are developed for providing higher data rates for subscribers. Implementation of new and expand of the existing technologies are needed. In cellular communication, actual step in evolving is implementation Voice over IP to 4G mobile networks.

In the specification 4G LTE by the 3rd Generation Partnership Project (3GPP) in release 8, it was designed as a pure packet switched system and either data services and real time services would be carried by the IP protocol. However, 3GPP formally announced VoLTE in February 2010 and GSMA announced “VoLTE Service Description and Implementation Guidelines” in October 2014. During this time mobile communications service providers (CSPs) is necessary to use solutions to move a subscriber from LTE to a legacy technology to obtain circuit switched voice service – CSFB (circuit switched fallback). During fallback data rate is decreased because of using legacy data services too, for example GPRS, EDGE or HSDPA. In addition, handover to latest generations increased call setup time twice.

Supporting voice over IP in a cellular communication system brings new challenges. Voice support in LTE requires the right mechanisms and architecture in radio and core networks, to guarantee quality of service and a good user experience because subscribers expect the same quality of service they know from circuit switched voice services, in GSM networks for example. Even after moving the voice services to VoIP, mobility between 4G and the previous cellular network generations is still the key problem.

The main task of this master thesis is:

- 1) Review the mobile system EPS and subsystem IMS, focus on the voice services and compare currently used solutions.
- 2) Analyze the issue of deployment of VoLTE services in Department of telecommunications to their experimental EPS-IMS network, and describe particular solution.
- 3) Like addition execute several VoLTE sessions, realize handover, capture and analyze it.
- 4) Suggest the laboratory exercise for MKPM course

The most important step is analyzing VoLTE architecture to understanding nodes, functions and interfaces functionality in complex. It was the key to find the better theoretical solution. The experimental LTE network on facility was in Phase one LTE implementation.

2 LTE

2.1 Evolution and deployment

Now 4G LTE is a newest mobile solution in the market. 3GPP evolution starts in 1999, when original UMTS was release. Then the other technologies was release that are using in 4G LTE:

| Year | Release | Technology |
|------|---------|--|
| 1999 | R99 | Original UMTS |
| 2000 | R4 | Basics of IMS |
| 2001 | R5 | HSDPA, complete design of IMS |
| 2002 | R6 | HSUPA, support for multimedia |
| 2004 | R7 | HSPA+, MIMO |
| 2007 | R8 | Defines the LTE and transition |
| 2008 | R9 | Further enhancements of LTE |
| 2011 | R10 | LTE Advanced |
| 2013 | R11 | Continue of LTE Advanced – advanced interconnection between services |

Table 2.1 3GPP evolution of technologies (1)

Historically, cellular technologies have adhered to an approximate 20-year cycle from launch to peak penetration, with around ten years between the launch of each new technology (see Figure 5). The first commercial LTE networks went live in 2009 and based on historical precedent we would not expect the technology to reach a peak level of connections until around 2030.

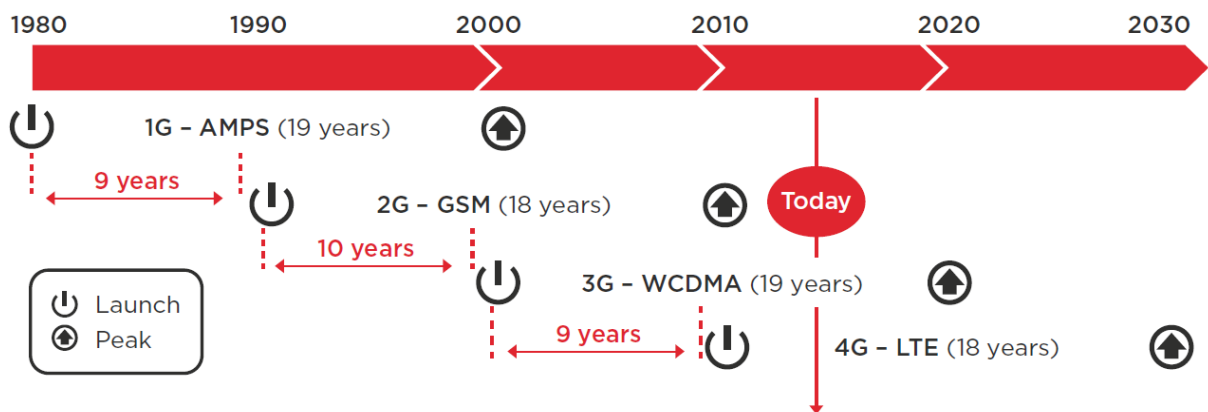

Figure 2.1 Evolution of mobile technology by generation, 1980 onwards (20)

These technologies are used to develop the final version of 4G LTE and deploying in three phases:

LTE Phase 1 – implementation EPC with oldies generation mobile networks. Uses for data services only.

LTE Phase 2 – voice implementation within 3G/2G – Circuit Switched Fall Back (CSFB).

LTE Phase 3 – Voice over LTE (VoLTE). Final phase, all mobile services handled by LTE network. Description of VoLTE released by GSM association (GSMA) in “VoLTE Service Description and Implementation Guidelines” in 2014. (2)

2.2 LTE characteristics and goals

Improved performance

- Efficient use of radio spectrum: UMTS had ~3 bps/Hz spectral utilization, LTE had 15 bps/Hz.
- High data rates: 100 Mbps downlink, 50 Mbps uplink
- Low latency: 10 ms and less, idle to activate transition under 100 ms

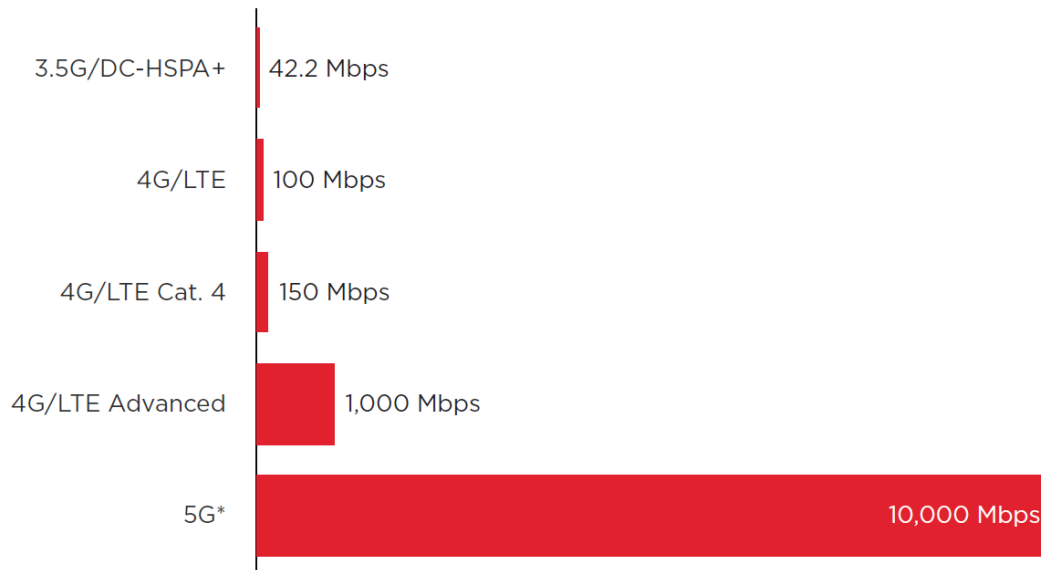

Figure 2.2 Maximum theoretical downlink speed by technology generation, Mbps (*10 Gbps is the minimum theoretical upper limit speed specified for 5G) (20)

Reduced costs

- Simplified architecture, minimum configuration. Only packet switched services was support, data services were shift away from 3G, leaving more capacity for Voice services in 3G.
- Less components delivering more services

Increased Value

Better user experience

Allow access to services anytime, anywhere

3 VoLTE architecture

The VoLTE logical architecture is based on the 3GPP defined architecture and principles. The main functional nodes of the VoLTE architecture are described below

3.1 UE

The VoLTE user equipment was use to connect eNB via the LTE-Uu radio interface. Other access technologies may also be supporting by the UE.

3.2 Evolved Universal Terrestrial Access Network – E-UTRAN architecture

E-UTRAN based on the “Flat architecture”, that allow to eliminates centralized controllers like RNC or BSC, and consist of a single node, the eNodeBs (eNB).

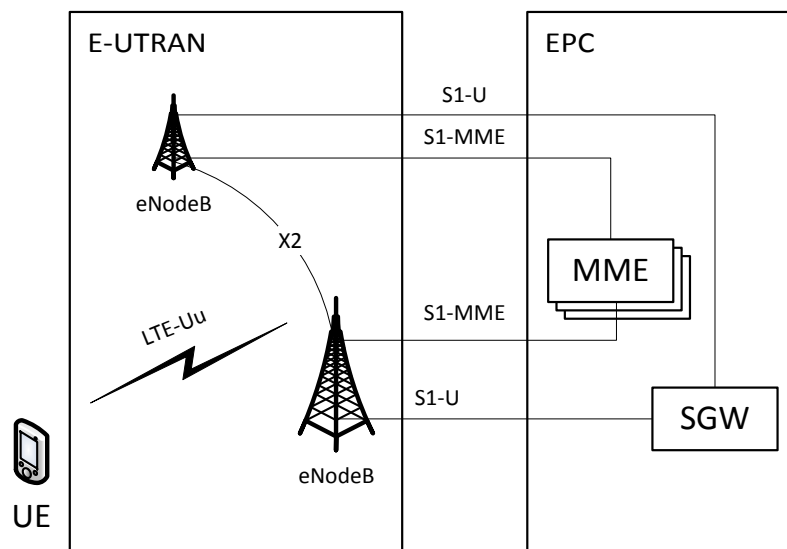

Figure 3.1 E-UTRA

For pooling resources, each eNB was connect to multiple MMEs and SGWs, that covering same geographical area. All-IP design – allow to delivering all services over the same infrastructure.

Interfaces:

S1mme – signaling

S1u – user data packets

eNodeB's interconnected via X2 interface. It allows eNB to connect directly, separated into control and user plane. If X2 interface available between two neighbor eNodeBs, this interface managing to handover within Mobile Management Entity (MME). Similar to S1u use GTP to carry user traffic.

eNB functions:

- Radio Resource Management (RRM) include radio bearer control and radio admission control
- IP header compression and user data encryption
- Uplink and downlink resource scheduling
- Transmission of paging messages and broadcast information
- Selection of MME
- Measurements (quality, performance)
- Routing of user data to the S-GW

LTE radio access network RAN are based on OFDMA orthogonal frequency-division multiple access and MIMO (multiple-input and multiple-output) technologies.

OFDMA goals:

- Scalability – able to utilize variable bandwidth
- Time and frequency scheduling – radio resources can be allocated over multiple channels and/or multiple transmission symbols
- Reduced interference – channels don't interfere
- Higher data rates – OFDM have plenty of channels and user can get multiple assigned
- MIMO support

In a difference of FDM, OFDM have not guard bands, which save bandwidth

3.3 Evolved packet core (EPC) architecture

3.3.1 Functions and nodes

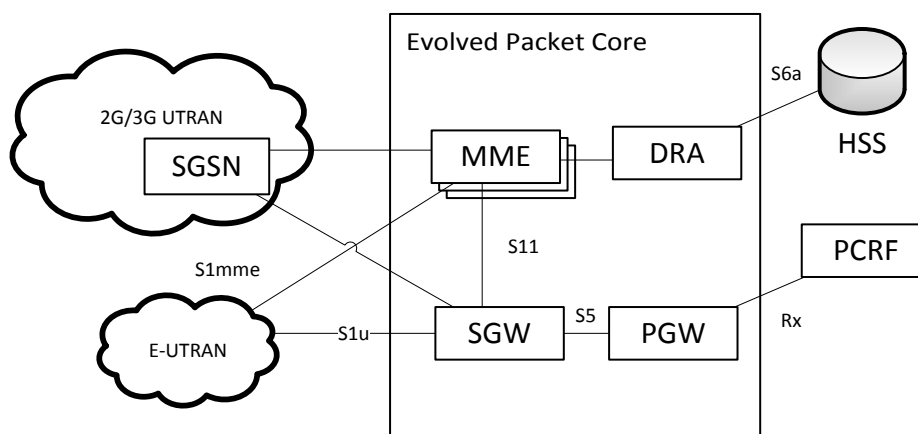

Figure 3.2 Evolved packet core architecture

MME – Mobility Management Entity is the key control-node for the LTE access network. It is signaling node only – not involved in user traffic. MME responsible for functions related to UE mobility:

- Managing and storing UE contexts
- Generation and allocation of temporary UE IDs

- Idle state mobility and roaming
- Security functions (authentication, authorization)
- Bearer path control (S-GW and P-GW selection)
- MME provides the control plane function for mobility between LTE and 2G/3G access networks and interfaces with the home HSS for roaming UEs.
- Support for other call control and session management entities

Home Subscriber Server (HSS) – network master database, which holds user subscription data (ID, numbering and service profiles) and provide authentication and authorization to the MME and IMS core during UE attach and IMS registration.

Packet Data Network Gateway (PGW) – default router for UE. Provide IP address allocation. Support policy and charging enforcement (PCEF), packet filtering for each user and performs marking for QoS management. UE may be connect to multiple PGW for accessing multiple Packet Data Networks. May coexist on same physical platform with SGW.

Serving gateway (SGW) routing and forwards packets between PGW and E-UTRAN, anchoring user plane during inter eNB handovers and as the anchor for mobility between LTE and other 3GPP technologies. Providing support for lawful interception. UE connected to one SGW.

Police and Charging Rules Function (PCRF) provides policy control decisions and flow based charging controls. Support for QoS in EPC network ensure that the user’s plane traffic mapping and treatment is in accordance with the user’s profile. Connected to PGW that implements policy and charging enforcement function (PCEF).

Diameter Relay Agent DRA is a function specialized in forwarding Diameter messages, provide roaming to other LTE networks. Support for more MMEs and HSSs. (3)

3.3.2 Interfaces

S1 interface connects E-UTRAN to EPC.

S1u – user plane: using GPRS Tunneling Protocol (GTP) on UDP. May be only one GTP tunnel per radio bearer. For QoS assigns level of service and priority to each packet used Differentiated Services Code Point (DSCP).

S1mme – Control plane interface between EUTRAN and MME. Carries S1 Application Protocol (S1AP) messages. Handle EPS bearer (setup and release), paging, NAS and handover signaling. For guaranteed data delivery over IP using Stream Control Transmission Protocol (SCTP), each SCTP association can support multiple UE. Provides redundancy and load sharing.

The **S5** interface provides user plane tunneling and tunnel management between SGW and PGW. The SGW and PGW may be realize as a single network element in which case the S5 interface is not exposed. (2)

The **S6a** interface enables the transfer of subscription and authentication data for authenticating/authorizing user access. The protocol used on the S6a interface is Diameter. (2)

The **S10** interface provides for MME – MME information transfer and was use to enable MME relocation. The protocol used on the S10 interface is GPRS Tunneling Protocol-Control plane (GTPv2-C). (2)

The **S11** interface is between the MME and S-GW to support mobility and bearer management. The protocol used on the S11 interface is GPRS Tunneling Protocol-Control plane (GTPv2-C). (2)

The **Gx** interface is between the PCRF and the PGW, allowing the PCRF direct control over the policy enforcement functions of the PGW. The protocol used on the Gx interface is Diameter. (2)

3.3.3 Protocols

The Non-Access Stratum is a set of protocols in the Evolved Packet System. The NAS is used to convey non-radio signaling between the User Equipment (UE) and the Mobility Management Entity (MME) for an LTE/E-UTRAN access. (4)

- Initiating and maintaining EPS bearers
- UE registration
- Moving S1 and radio bearers during mobility
- Carried over S1mme

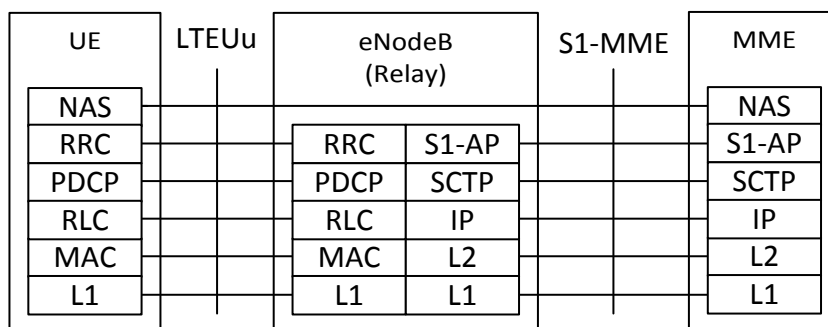

Figure 3.3 EPS control plane for E-UTRAN access (4)

User plane protocols using GTPv1 on all interfaces.

X2AP – tunnels between eNBs during inter-eNB mobility

S1AP is the S1 application protocol between the EUTRAN and MME. S1AP provides bearer management. Was use to establish an S1UE context in the eNB, to setup the default IP connectivity. (5)

3.4 IP multimedia subsystem (IMS) architecture

IMS is the control infrastructure for supporting next generation IP Multimedia Services and consists of many separate elements.

Logically IMS can be divide by functional layers:

1. Control layer provides manage the session control, authorization, call routing and billing. The S-CSCF is the main call control element.
2. Service layer provides specific services (including telephony) implemented by Application Servers (AS). Once S-CSCF invokes a service, the AS can control the processing of the session
3. Media layer. Media processing – announcements servers, conference bridges, media servers – this layer is under control of the other two layers. Media Gateways are responsible for codec conversion. MGCF is physically implemented in 3G MSC

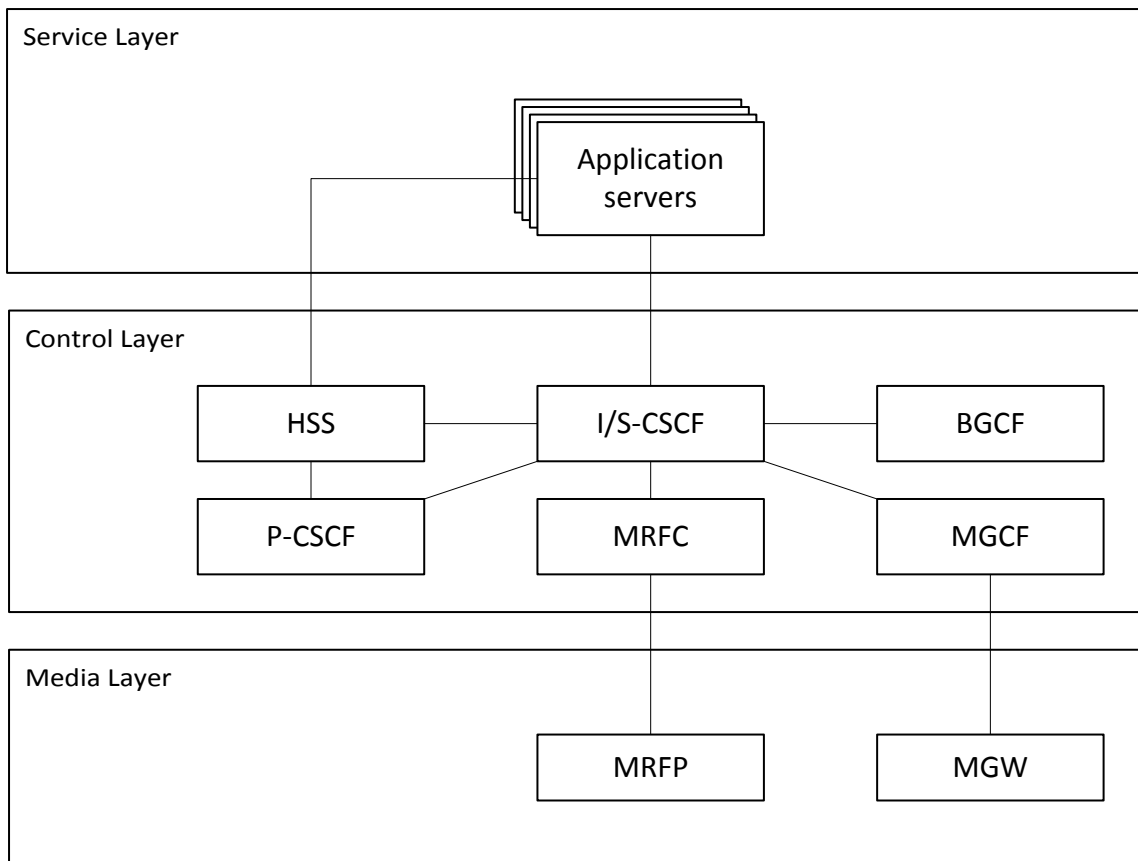

Figure 3.4 IMS network architecture layers

3.4.1 Functions

The **Call Session Control Function (CSCF)** may take on various roles as used in the IP multimedia subsystem. The following sections describe these various roles.

The **Proxy-CSCF (P-CSCF)** is the first contact point within the IM CN subsystem. Its address is discovered by UEs following PDP context activation, using the mechanism described in section “Procedures related to Local CSCF Discovery”. The P-CSCF behaves like a Proxy (as defined in

RFC2543 or subsequent versions), i.e. it accepts requests and services them internally or forwards them on, possibly after translation. The P-CSCF may also behave as a User Agent (as defined in the RFC2543 or subsequent versions), i.e. in abnormal conditions it may terminate and independently generate SIP transactions.

The Policy Control Function (PCF) is a logical entity of the P-CSCF. If the PCF was implemented in a separate physical node, the interface between the PCF and the P-CSCF is not standardized.

The functions performed by the P-CSCF are:

1. Forward the SIP register request received from the UE to an I-CSCF determined using the home domain name, as provided by the UE.
2. Forward SIP messages received from the UE to the SIP server (e.g. S-CSCF) whose name the PCSCF has received as a result of the registration procedure.
3. As part of processing of the request and before forwarding, the P-CSCF may modify the Request URI of outgoing requests according to a set of provisioned rules defined by the network operator (e.g. Number analysis and potential modification such as translation from local to international format.)
4. Forward the SIP request or response to the UE.
5. Detect an emergency session and select a S-CSCF in the visited network to handle emergency sessions. Interrogating – CSCF – is responsible for determining with which S-CSCF is the UE registered. The main functions of the I – CSCF are Select the S – CSCF during registration and load balancing across the S – CSCF.

Authorisation of bearer resources and QoS management. Details of the P-CSCF role in QoS management and authorisation of bearer resources for the session are being investigated by the QoS ad-hoc group. (6)

Interrogating-CSCF (I-CSCF) is the contact point within an operator's network for all connections destined to a subscriber of that network operator, or a roaming subscriber currently located within that network operator's service area. There may be multiple ICSCFs within an operator's network.

The functions performed by the I-CSCF are:

1. Registration: Assigning a S-CSCF to a user performing SIP registration (see section on Procedures related to Serving-CSCF assignment)
2. Session Flows: Route a SIP request received from another network towards the S-CSCF, obtain from HSS the Address of the S-CSCF and forward the SIP request or response to the S-CSCF.

In performing the above functions, the operator may use the I-CSCF or other techniques to hide the configuration, capacity, and topology of the network from the outside. When the I-CSCF was chosen to meet the hiding requirement then for sessions traversing across different operators domains, the I-CSCF may forward the SIP request or response to another I-CSCF allowing the operators to maintain configuration independence. (6)

Serving – CSCF – performs session management for subscriber's IMS based services. S-CSCF was selected during SIP registration. Selection was based on their ability to handle by authorized subscriber.

Within an operator's network, different S-CSCFs may have different functionalities. The functions performed by the S-CSCF during a session are:

Registration. May behave as a Registrar, accepts registration requests and makes its information available through the location server (e.g. HSS).

Session flows. Assure session control for the registered endpoint's sessions. Interact with Services Platforms for the support of services; provide endpoints with service event related information (e.g. notification of tones/announcement together with location of additional media resources, billing notification).

On behalf of an originating endpoint, obtain from a database the address of the I-CSCF for the network operator. When the destination subscriber is a customer of a different network operator, serving the destination subscriber from the destination name of the terminating subscriber (e.g. dial phone number or SIP URL), and forward the SIP request or response to that I-CSCF. When the destination name of the terminating subscriber (e.g. dial phone number or SIP URL), and the destination subscriber is a customer of the same network operator, forward the SIP request or response to an I-CSCF within the operator's network.

On behalf of a destination endpoint (i.e. the terminating subscriber/UE), forward the SIP request or response to a P-CSCF for a MT session to a home subscriber within the home network, or for a subscriber roaming within a visited network where the home network operator has chosen not to have an I-CSCF in the path. Forward the SIP request or response to an I-CSCF for a MT session for a roaming subscriber within a visited network where the home network operator has chosen to have an I-CSCF in the path. (6)

Breakout Gateway Control Function (BGCF) based on local configuration may be provision as the contact point within an operator's network for transit IMS scenarios. Otherwise, the BGCF processes requests for routing from an S-CSCF for the case were the S-CSCF has determined that the session cannot be routed using DNS or ENUM/DNS

The BGCF determines the next hop for routing the SIP message. This determination may be basing on information received in the protocol, administrative information, and/or database access. For PSTN terminations, the BGCF determines the network in which PSTN/CS Domain breakout is to occur. If the routing determination is such that the breakout is to occur in the same network in which the BGCF is located, then the BGCF shall select a MGCF that will be responsible for the interworking with the PSTN/CS Domain. If the routing determination results in break out in another network, the BGCF will forward this session signaling to another BGCF in the selected network. If the routing determination results in the session being destined for another IMS network, the BGCF forwards the message to an I-CSCF in this IMS network. If the BGCF determines that there is another IP destination for the next hop, it forwards the message to that contact point.

There may be multiple BGCFs within an operator's network. The functions performed by the BGCF are:

1. Determines the next hop for SIP routing.

2. For PSTN terminations, select the network in which the interworking with the PSTN/CS Domain is to occur. If the interworking is in another network, then the BGCF will forward the SIP signaling to the BGCF of that network.
3. For PSTN terminations, select the MGCF in the network in which the interworking with PSTN/CS Domain is to occur and forward the SIP signaling to that MGCF. This may not apply if the interworking is a different network.

The BGCF may make use of information received from other protocols, or may make use of administrative information, when making the choice of which network the interworking shall occur. (6)

Multimedia Resource Function (MRF) is splitting into Multimedia Resource Function Controller (**MRFC**) and Multimedia Resource Function Processor (**MRFP**).

Tasks of the MRFC are the following:

Control the media stream resources in the MRFP.

Tasks of the MRFP include the following:

1. Control of the bearer on the Mb reference point.
2. Provide resources to be controlling by the MRFC.
3. Mixing of incoming media streams (e.g. for multiple parties).
4. Media stream source (for multimedia announcements).
5. Media stream processing (e.g. audio transcoding, media analysis).
6. Floor Control (i.e. manage access rights to shared resources in a conferencing environment).

Interpret information coming from an AS and S-CSCF (e.g. session identifier) and control MRFP accordingly. Application Server concerning MRF conference booking and manage booking information (e.g. start time, duration, and list of participants). (6)

3.4.2 IMS interfaces description.

Rx Interface (PCRF – P-CSCF)

The Rx interface is between the appropriate Application Function (the P-CSCF in the case of VoLTE) and the PCRF allowing the Application Function to request the application of an appropriate policy for a session. The protocol used on the Rx interface is Diameter.

SGi Interface (PGW – P-CSCF)

The SGi interface is between the PGW and the P-CSCF within the IMS Network. The Gm reference point from the UE to P-CSCF is tunneled within SGi for VoLTE services. SGi is IP-based.

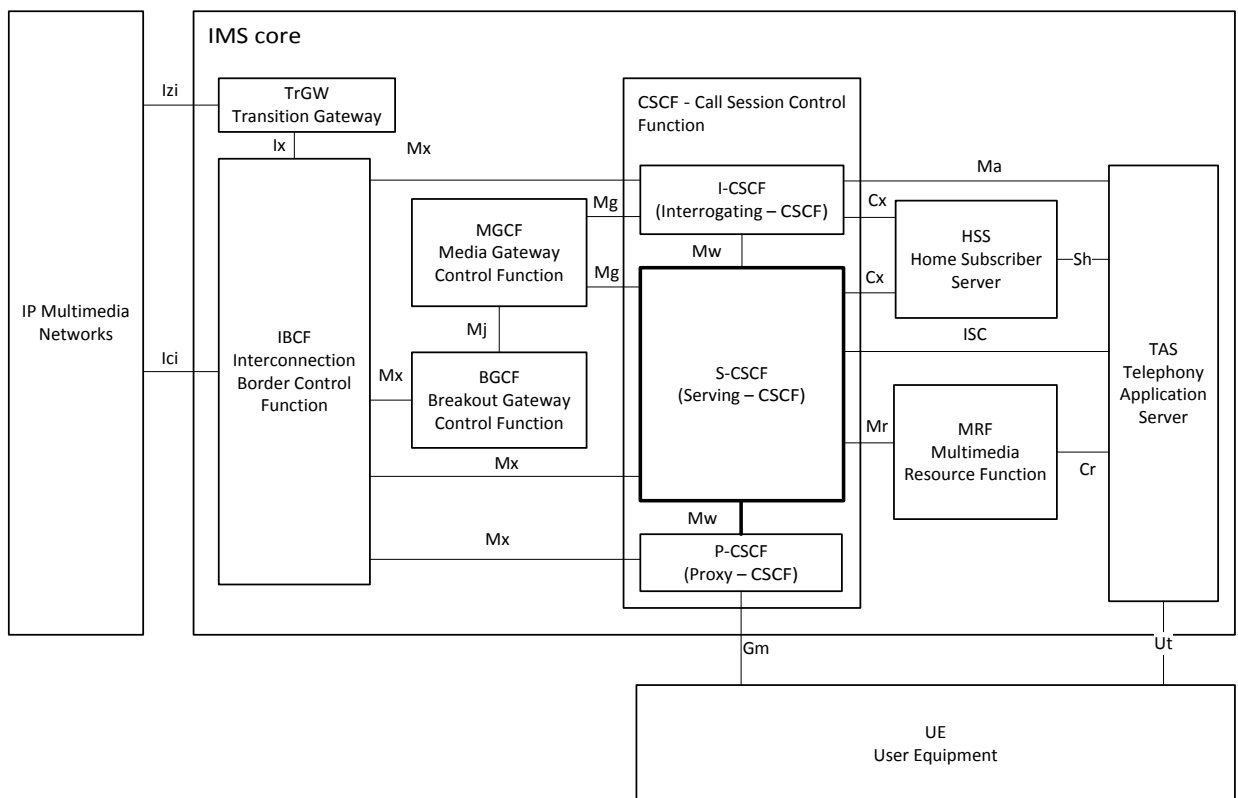

Figure 3.5 Architecture of the IP Multimedia Core Network Subsystem

Cx Interface (I/S-CSCF – HSS)

The Cx interface is between the I/S CSCF and HSS to enable IMS registration and passing of subscriber data to the S-CSCF. The protocol used on the Cx interface is Diameter.

Sh Interface (VoLTE AS – HSS)

The Sh interface is between the VoLTE Application Server and HSS to enable service and subscriber related information to be passed to the Application Server or stored in the HSS. The protocol used on the Sh interface is Diameter.

Gm Interface (UE – P-CSCF)

The Gm interface is between the UE and the P-CSCF and enables connectivity between the UE and the IMS network for registration, authentication, encryption, and session control. The protocol used on the Gm interface is SIP/SDP.

Ut Interface (UE – TAS)

The Ut interface is between the UE and the TAS and allows user configuration of the supplementary services specified for VoLTE service. The protocol used on the Ut interface is XCAP.

Mx Interface (x-CSCF – IBCF)

The Mx interface is between CSCF and IBCF used for the interworking with another IMS network. The protocols used on the Mx interface are SIP and SDP.

Mw Interface (x-CSCF – x-CSCF)

The Mx interface is between a x-CSCF and another x-CSCF within the IMS core network (e.g. P-CSCF to I/S-CSCF). The protocols used on the Mw interface are SIP and SDP.

Mg Interface (xCSCF – MGCF)

The Mg reference point allows the MGCF to forward incoming SIP/SDP messages that the MGCF has interworked from the CS Network to the CSCF. The protocols used on the Mg interface are SIP and SDP.

Mi Interface (xCSCF – BGCF)

The Mi reference point allows the Serving CSCF to forward the SIP/SDP messages to the Breakout Gateway Control Function for the purpose of MGCF selection for interworking with CS networks. The protocols used on the Mi interface are SIP and SDP.

Mj Interface (BGCF – MGCF)

The Mj reference point allows the Breakout Gateway Control Function to exchange SIP/SDP messages with the BGCF for the purpose of interworking with CS networks. The protocols used on the Mj interface are SIP and SDP.

ISC Interface (S-CSCF –TAS)

The ISC interface is between S-CSCF and Telephony Application Server and is used to interact with the MMTel supplementary services implemented on the TAS. The protocol used on the ISC interface is SIP.

Mr Interface (S-CSCF – MRF)

The Mr interface is between the S-CSCF and the MRF to allow interaction with the media resource for specific supplementary services (e.g. conference call). The protocol used on the Mr interface is SIP/SDP.

Mr' Interface (TAS – MRF)

The Mr' interface is between the Telephony Application Server and the MRF to allow interaction with the media resource for specific supplementary services (e.g. conference call). The protocol used on the Mr' interface is SIP/SDP.

Cr Interface (TAS – MRF)

The Cr interface is between the Telephony Application Servers and the MRF. And is used for sending/receiving XML encoded media service requires (Cr) which are served by the MRF.

Mb Interface (media bearer)

Mb interface is the media bearer plane between UEs and network elements that interact with the bearer (e.g. MRF). The protocol is based on symmetric RTP/RTCP over UDP.

Ici Interface (IBCF – IBCF)

Ici interface is between an IBCF and another IBCF or I-CSCF belonging to a different IMS network. The protocols used on the Ici interface are SIP and SDP.

Izi Interface (TrGW – TrGW)

The Izi interface is between a TrGW and another TrGW or media handling node belonging to a different IMS network. The protocols used on the Izi interface are RTP and MSRP.

3.4.3 IMS protocols

For UE and IMS subsystem connectivity, in particular of voice services, important the following protocols:

- Session Initial Protocol (SIP)
- Session Description Protocol (SDP)
- Real-time Transport Protocol (RTP)
- RTP Control Protocol (RTCP)
- IP Security (IPsec)

Session Initial Protocol (SIP)

Session Initial Protocol is used to create, modify and terminate multimedia sessions. It is client-server signaling protocol, for delivering media tasks is used RTP/RTCP. SIP is a sequential request-response protocol. Every SIP request begins with a starting line that includes the name of the method (request type). A Request-Line contains a method name, a Request-URI, and the protocol version separated by a single space (SP) character. The Request-Line ends with CRLF.

Request-Line example: Method SP Request-URI SP SIP-Version CRLF

| SIP Request Method | Description |
|--------------------|---|
| INVITE | Indicates that a client is being invited to participate in a call session (7) |
| ACK | Confirms that the client has received a final response to an INVITE request (7) |
| BYE | Terminates a call; can be sent by either the caller or the called party (7) |
| CANCEL | Cancels any pending request (7) |
| OPTIONS | Queries the capabilities of servers (7) |
| REGISTER | Registers the address listed in the To header field with a SIP server (7) |
| PRACK | Provisional acknowledgement (8) |
| SUBSCRIBE | Subscribes to event notification (9) |
| NOTIFY | Notifies the subscriber of a new Event (9) |
| PUBLISH | Publishes an event to the Server (10) |
| INFO | Sends mid-session information that does not modify the session state (11) |
| REFER | Asks recipient to issue a SIP request (call transfer) (12) |
| MESSAGE | Transports instant messages using SIP (13) |
| UPDATE | Modifies the state of a session without changing the state of the dialog (14) |

Table 3.1 SIP Request Methods description

SIP responses are distinguished from requests by having a Status-Line as their start-line. A Status-Line consists of the protocol version followed by a numeric Status-Code and its associated textual phrase, with each element separated by a single SP character.

Status-Line example: SIP-Version SP Status-Code SP Reason-Phrase CRLF

```

Request start line   INVITE sip:13@10.10.1.13 SIP/2.0
Request header      Via: SIP/2.0/UJP
                   10.10.1.99:5060;branch=z9hG4bK343b:628;rport
                   From: "Test 15" <sip:15@10.10.1.99>tag=as58f4201b
                   To: <sip:13@10.10.1.13>
                   Contact : <sip:15@10.10.1.99>
                   Call-ID: 326371826c80e17e6c:6c29861eb2933@10.10.1.99
                   CSeq: 102 INVITE
                   User-Agent : Asterisk PBX
                   Max-Forwards : 70
                   Date: Wed, 06 Dec 2009 14 :12 :45 GY.T
                   Allow: INVITE, ACK, CANCEL, OPTIONS, BYE, REFER,
                   SUBSCRIBE,
                   NOTIFY
                   Supported: replaces
                   Content-Type : application/adp
                   Content-Length: 258

<blank line>
Message body        v=0
(SDP message)      o=Joe Spirent 1821 1821 IN IP4 10.10.1.99
                   s=Spirent Seminar : IMS & VoLTE
                   c=IN IP4 10.10.1.99
                   t=0 0
                   m=audio 11424 RTP/AVP 0 8 101
                   a=rtpmap:0 PCMU/8000
                   a=rtpmap:8 PCMA/8000
                   a=rtpmap:101 telephone-event/8000
                   a=fmtp:101 0-16
                   a=silenceSupp:off - - - -
                   a=ptime:20
                   a=sendrecv

```

Table 3.2 Sample SIP request with SDP in message body from SPIRNET seminar (15)

Session Description Protocol (SDP)

Session Description Protocol (SDP) – is used to describe multimedia sessions. SDP is contained in the body part of SIP. An SDP message is composed of a fields , whose names are abbreviated by a single lower-case letter. It conveys the name and purpose of the session, the media, protocols, codec formats, timing and transport information.

For example in Table 3.2 Sample SIP request with SDP in message body from SPIRNET seminar the SDP message body describes the owner (“Joe Spirent”), the session (“Spirent Seminar: IMS &VoLTE”), some connection information (IP4 10.10.1.99), the media (audio) and some suggested attributes of the media (PCMU, PCMA, etc.). (15)

Real-time Transport Protocol (RTP) and RTP Control Protocol

IMS subsystem uses RTP as the media data transfer protocol. RTP provides end-to-end delivery services for data with real-time characteristics, such as interactive audio and video. RTCP in IMS is used to provide Quality of Service (QoS) information and for synchronizing RTP streams. RTP and RTCP are always paired in port assignments. One port is used for audio data, and the other is used for control (RTCP) packets. For example: if RTP port equals “n”, then RTCP port will be equal “n+1”.

The audio conferencing application used by each conference participant sends audio data in small chunks of, say, 20 ms duration. Each chunk of audio data is preceded by an RTP header; RTP header and data are in turn contained in a UDP packet. The RTP header indicates what type of audio encoding (such as PCM, ADPCM or LPC) is contained in each packet so that senders can change the encoding during a conference, for example, to accommodate a new participant that is connected through a low-bandwidth link or react to indications of network congestion. (16)

The Internet, like other packet networks, occasionally loses and reorders packets and delays them by variable amounts of time. To cope with these impairments, the RTP header contains timing information and a sequence number that allow the receivers to reconstruct the timing produced by the source, so that in this example, chunks of audio are contiguously played out the speaker every 20 ms. This timing reconstruction is performed separately for each source of RTP packets in the conference. The sequence number can also be used by the receiver to estimate how many packets are being lost. (16)

Since members of the working group join and leave during the conference, it is useful to know who is participating at any moment and how well they are receiving the audio data. For that purpose, each instance of the audio application in the conference periodically multicasts a reception report plus the name of its user on the RTCP (control) port. The reception report indicates how well the current speaker is being received and may be used to control adaptive encodings. In addition to the user name, other identifying information may also be included subject to control bandwidth limits. A site sends the RTCP BYE packet when it leaves the conference. (16)

4 VoLTE service requirements

4.1 Adaptive Multi-Rate (AMR) Speech Codec

The AMR codec is originally developed and standardized by the European Telecommunications Standards Institute (ETSI) for GSM cellular systems. It is now chosen by the Third Generation Partnership Project (3GPP) as the mandatory codec for 3G and 4G cellular systems.

The AMR codec is a multi-mode codec that supports eight narrow band speech encoding modes with bit rates between 4.75 and 12.2 kbps. The sampling frequency used in AMR is 8000 Hz and the speech encoding is performed on 20 ms speech frames. Therefore, each encoded AMR speech frame represents 160 samples of the original speech.

Similar to AMR, the AMR-WB codec is also a multi-mode speech codec. AMR-WB supports nine wide band speech coding modes with respective bit rates ranging from 6.6 to 23.85 kbps. The sampling frequency used in AMR-WB is 16000 Hz and the speech processing is performed on 20 ms frames. This means that each AMR-WB encoded frame represents 320 speech samples. Both codecs support voice activity detection (VAD) and generation of comfort noise (CN) parameters during silence periods.

The main requirements of AMR

- UE has to support all modes
- If wideband AMR is available, it has to be supported too
- Both (UE and network) must support wideband modes 12.65, 8.85 and 6.6 kbps
- AMR coder takes 20 ms samples of speech and encodes them into frames
- Frames must be transferring across the network - RTP
- Delay between speech generation and reception should be below 150 ms else human can notice quality degradation
- License for using AMR

4.2 Robust Header Compression

UE and network must support Robust Header Compression (RoHC). The UE and network must be able to apply the compression to packets that were carry over the radio bearer dedicated for the voice media. At minimum, UE and network must support "RTP/UDP/IP" to compress RTP packets and "UDP/IP" to compress RTCP packets. The UE and network must support these profiles for both IPv4 and IPv6. (17)

4.3 LTE Radio Capabilities

LTE Signaling radio bearers (SRB) are used for the transfer of RRC and NAS signaling messages.

1. RRC messages are used as signaling between UE and eNodeB.
2. NAS (Non Access Stratum) messages are used as signaling between UE and MME.

(18)

RRC messages can be used to encapsulate NAS messages for their transfer between UE and eNodeB. The S1 application protocol is later used to transfer NAS messages between eNodeB and MME. The UE must support the following combination of radio bearers for Voice over IMS:

SRB1 + SRB2 + 4 x AM DRB + 1 x UM DRB

The network must support the following combination of radio bearers:

SRB1 + SRB2 + 2 x AM DRB + 1 x UM DRB

One AM Data Radio Bearer (DRB) is utilized for Evolved Packet System (EPS) bearer with Quality of Service Class Indicator (QCI) = 5 and another AM DRB for EPS bearer with QCI = 8/9. UM DRB is utilized for EPS bearer with QCI = 1. (17)

| LTE SRB Type | Direction | RRC message | RLC Mode |
|------------------------|-----------|--|-------------|
| LTE SRB0 (CCCH) | Downlink | RRC Connection Setup RRC Connection Reject RRC Connection Re-establishment RRC Connection Re-establishment reject | Transparent |
| | Uplink | RRC Connection Request RRC Connection Re-establishment Request | |
| LTE SRB1(DCCH) | Downlink | RRC Connection Reconfiguration RRC Connection Release Security Mode Command UE Capability Enquiry DL information transfer(if no SRB-2) Mobility from EUTRA Command Handover from EUTRA preparation request CS Fallback parameter response CDMA2000 Counter Check | |
| | Uplink | RRC Connection Setup Complete Security Mode Complete Security Mode Failure RRC Connection Reconfiguration Complete RRC Connection Re-establishment Complete Measurement report UE Capability information UL Information Transfer(if no SRB2) UL handover preparation transfer CS fallback parameters request CDMA2000 Counter Check response | |
| LTE SRB2 (DCCH) | Downlink | DL Information Transfer | |
| | Uplink | UL Information Transfer | |

Table 4.1 LTE Signaling Radio Bearer types (18)

4.4 RLC configurations

Radio Link Control (RLC) entity must be configured to perform data transfer in the following modes;

- Unacknowledged Mode (UM) for EPS bearers with QCI = 1
- Acknowledged Mode (AM) for EPS bearers with QCI = 5
- Acknowledged Mode (AM) for EPS bearers with QCI = 8/9

Voice service can tolerate error rates on the order of 1%, while benefiting from reduced delays, and is mapped to a radio bearer running the RLC protocol in unacknowledged mode (UM).

4.5 Guaranteed bit rate (GBR) bearer

Voice is one of the LTE services that require a guaranteed bit rate (GBR) bearer, although it is a very low data rate compared to LTE peak rates. The GBR bearer for voice requests dedicated network resources related to the Guaranteed Bit Rate (GBR) for AMR codec values. The network resources associated with the EPS bearer supporting GBR must be permanently allocated by admission control function in the eNodeB at bearer establishment. Reports from UE, including buffer status and measurements of UE's radio environment, must be required to enable the scheduling of the GBR. In UL it is the UE's responsibility to comply with GBR requirements. (17)

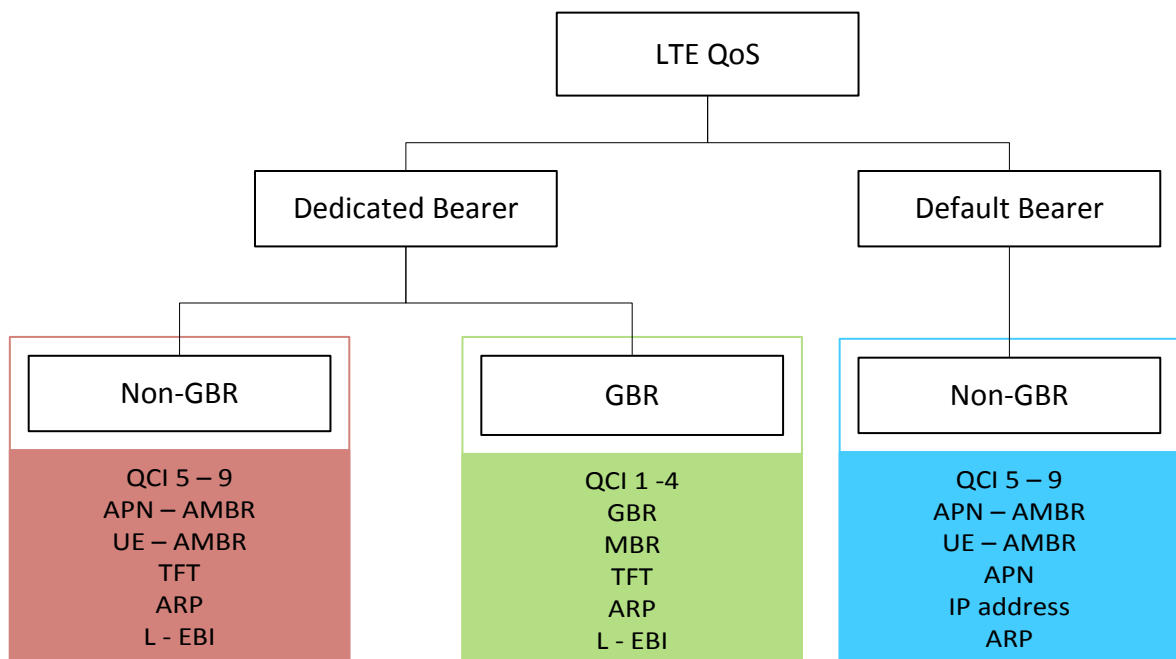

Figure 4.1 Bearer types and properties (19)

Dedicated bearer can be subdivided into Non-GBR and GBR types. GBR provides guaranteed bit rate and is associated with parameters like GBR and MBR

1. GBR: The minimum guaranteed bit rate per EPS bearer. Specified independently for uplink and downlink
2. MBR: The maximum guaranteed bit rate per EPS bearer. Specified independently for uplink and downlink

On the other hand, Non-GBR bearer does not provide guaranteed bit rate and has parameter like A- AMBR and UE- AMBR. (19)

1. A-AMBR: APN Aggregate maximum bit rate is the maximum allowed total non-GBR throughput to specific APN. It is specified interdependently for uplink and downlink
2. UE -AMBR: UE Aggregate maximum bit rate is the maximum allowed total non-GBR throughput among all APN to a specific UE

For an IMS session request for a Conversational Voice call (originating and terminating), a dedicated bearer for IMS-based voice must be created utilizing interaction with dynamic PCC. The network must initiate the creation of a dedicated bearer to transport the voice media. The dedicated bearer for Conversational Voice must utilize the standardized QCI value of one (1) and have the associated characteristics. (17)

The network must not create more than one dedicated bearer for voice media. Therefore, the UE and network must be able to multiplex the media streams from multiple concurrent voice sessions. (17)

For IMS session termination of a Conversational Voice call, the dedicated bearer must be deleted utilizing interaction with dynamic PCC. The network must initiate the deletion of the bearer.

4.6 P-CSCF Discovery

The UE and packet core must support the procedures for P-CSCF discovery via EPS. The UE shall indicate P-CSCF IPv6 Address Request and P-CSCF IPv4 Address Request when performing the following procedures:

1. During the initial attach when establishing PDN connection to the default APN,
2. During the initial attach when establishing PDN connection to the IMS well-known APN, and
3. During the establishment of the PDN connection to the IMS well-known APN when already attached,
4. During the attach procedure for emergency bearer services, and
5. During the establishment of the PDN connection for emergency bearer services when already attached.

The UE must use the P-CSCF addresses received during PDN connection establishment to the IMS well-known APN when accessing non-emergency services, and must use the P-CSCF addresses received during PDN connection establishment for emergency bearer services when accessing emergency services. (17)

4.7 Addressing

The UE and IMS core network must support Public User Identities, which includes all of the following types of addresses:

Alphanumeric SIP-URIs. Example: sip:voicemail@example.com

MSISDN represented as a SIP URI. Example: sip:+447700900123@example.com;user=phone

MSISDN represented as a Tel URI. Example: tel:+447700900123

4.8 Handovers

- Handover are still needed for mobility
- eNB knows the QCI but not the service
- It can change process based on QCI
- Signaling is used to announce any changes
- “Data forwarding” feature – forwards data from old eNB to the new eNB while handover is in progress
- X2 and S1 handovers are not impacted by VoLTE

5 The basic call flows scenarios

The basic call flows that cover the following scenarios: (2)

1. Attachment and IMS Registration
2. Detachment and IMS de-registration
3. IMS voice call establishment and teardown
4. IMS multimedia (voice/video) call establishment and teardown
5. Adding video to an established voice call
6. Removing video from an established multi-media call

During my work in VoLTE implementation, I target on three main situations: VoLTE UE Attachment and IMS Registration, VoLTE UE to VoLTE UE Voice Call Establishment and Clearing.

5.1 Attachment and IMS Registration

5.1.1 Default Bearer establishment for attach to IMS

RRC CONNECTION REQUEST message is used to request the E-UTRAN for the establishment of an RRC connection. It is sent as part of the Random Access procedure. It is transferred using SRB0 on the Common Control Channel (CCCH) because neither SRB1 nor a Dedicated Control Channel (DCCH) has been setup at this point.

As the next step, the VoLTE UE initiates the Attach Request to the eNodeB. With mandatory information including:

- EPS Attach Type
- NAS key set identifier
- IMSI
- UE network capability
- DRX parameters
- PDN Type (set to IPv4v6)
- PCO (P-CSCF IPv4 Address Request, P-CSCF IPv6 Address Request, IPv4 Link MTU Request)
- Voice Domain Preference and UE's Usage Setting (indicating support of IMS voice)
- ESM message container

The eNodeB selects the MME from the RRC parameters and forwards the Attach Request to the MME with the Selected Network and the TAI+ECGI location information of the cell where it received the message.

Authentication and security mechanisms are performed to activate integrity protection and NAS ciphering. The MME shall initiate the Security Mode Command to the UE that containing:

- The Selected NAS algorithms
- EKSf
- ME Identity request

- UE Security Capability

The UE responds with the Security Mode Complete with the NAS-MAC and ME Identity. After the completion, all NAS messages are protected by the NAS security functions (integrity and ciphering).

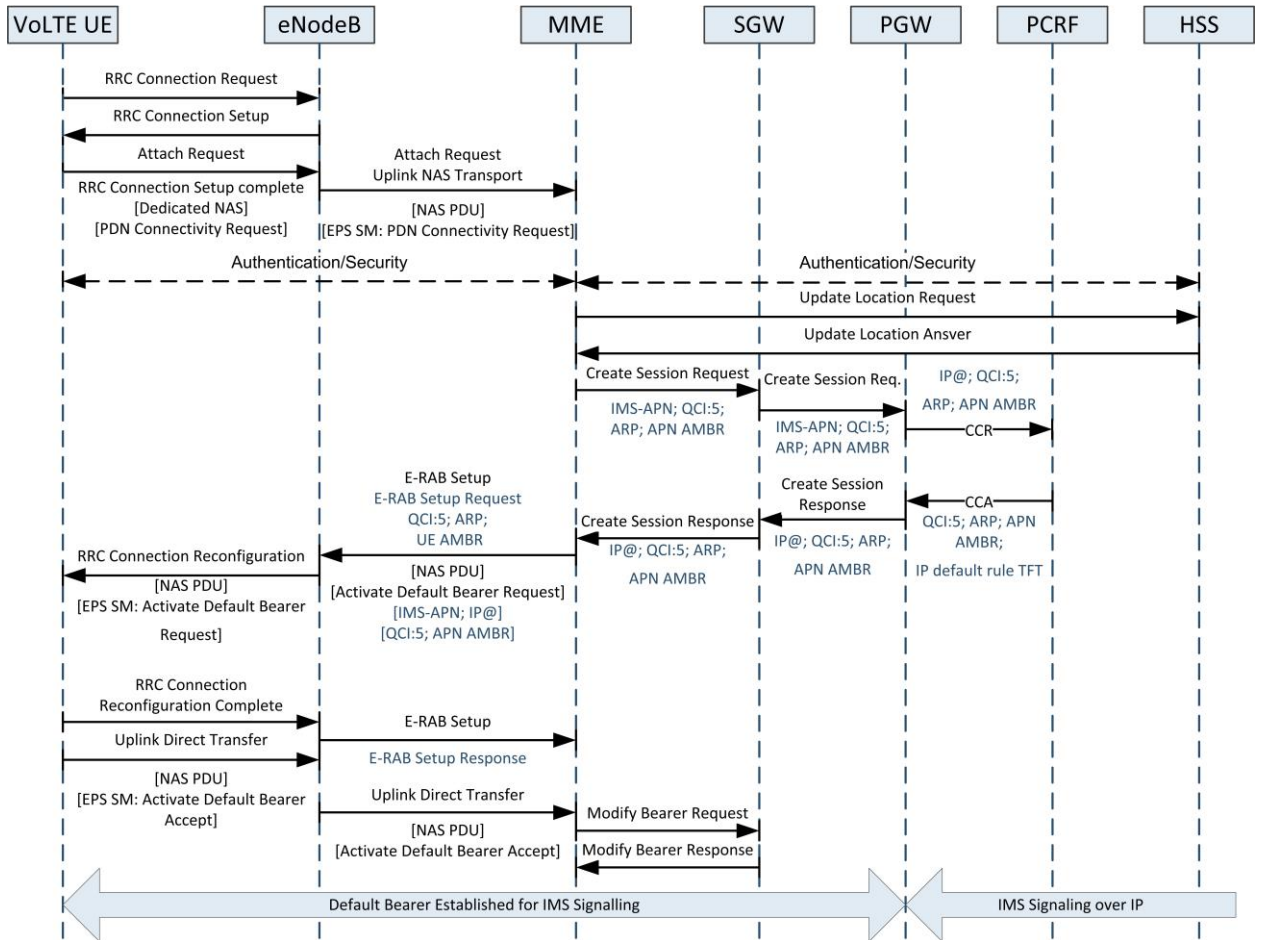

Figure 5.1 VoLTE UE attachment and default bearer establishment message sequence

The MME performs an Update Location to the HSS to retrieve the subscriber profile. Additional information:

- International Mobile Subscriber Identity (IMSI)
- MME Identity
- ME Identity
- MME capabilities
- Homogenous support for IMS Voice over PS session

The HSS confirms the Update Location to the MME with the related IMSI and subscriber data containing a PDN subscription context with a subscribed QoS profile and subscribed APN-AMBR (Aggregate Maximum Bit Rate).

The MME initiates a Create Session Bearer request to the SGW to create a default bearer for VoLTE IMS signaling. This message contains:

- IMSI

- MSISDNIMS-APN
- QCI=5
- ARP value
- APN-AMBR
- user location information (TAI+ECGI)
- UE Time Zone
- RAT-type (EUTRAN)
- PCO

The SGW creates a new entry in the EPS Bearer table, allocating a relevant TEID for the control plane and the user plane, which enables it to route GTP control plane traffic between the MME and the PGW, and forwards the request to the PGW.

The PGW allocates an IP Address (which can be IPv4 or IPv6) for the UE and utilizes dynamic PCC to initiate a Credit Control Request to the PCRF to obtain the default PCC rules for the default bearer to be used for IMS signaling. Message also include:

- IMSI
- UE IP Address
- default bearer QoS parameters (i.e. QCI=5, ARP, APN-AMBR)
- user location information
- time zone information
- RAT type (EUTRAN)

The PCRF binds the related policy rules to the IP Address of the default bearer, and responds to the PGW with the default TFT (traffic flow template) and potentially modified QoS parameters. The PGW creates a new entry in the EPS Bearer table, allocating relevant TEID for the control plane and the user plane, which enables it to route user plane data between the SGW and the IMS network with the related policy rules obtained from the PCRF applied.

- The PGW sends a Create Session Response to the SGW with the follow parameters:
- IP Address for the UE
- QoS parameters
- PCO
- Relevant TEID's for the GTP control plane and GTP user plane

The PGW maps the IMS-APN received in the request to a pre-configured IMS P-CSCF IP address and inserts this into the PCO.

The SGW returns the Create Session Response to the MME.

The MME sends an Attach Accept to the eNodeB with:

- IMS-APN
- IP Address for the UE
- QoS parameters
- PCO
- IMS Voice over PS supported indication
- TAI list

- ESM message container

The eNodeB communicates with the UE to update the RRC configuration and includes the information received from the core network as part of the create session request.

The UE sends the Attach Complete message to the eNodeB, which forwards to the MME. At this time, the UE is capable of sending uplink packets.

The MME initiates a Modify Bearer Request to the SGW including:

- EPS Bearer Identity
- eNodeB address
- and eNodeB TEID

The SGW acknowledges the request to the MME and is capable of sending downlink packets.

At this stage, the VoLTE UE is attached to the network via a default bearer that is established for IMS Signaling.

5.1.2 IMS registration

The VoLTE UE initiates a SIP REGISTER to the P-CSCF, using the P-CSCF IP Address that was made available during the LTE Attach. The registration request contains:

- Within the Contact header, the IMS Communication Service Identifier's (ICSI) for IMS Multimedia Telephony:
 - urn:urn-7:3gpp-service.ims.icsi.mmtel, or urn:urn-7:3gpp-service.ims.icsi.mmtel;video
 - sip.instance" containing an IMEI URN
- The feature tag for SMS over IP:- +g.3gpp.smsip
- The IMS Public User Identity (as derived above) in one of the forms below:-
 - Alphanumeric SIP-URI: e.g. user@example.com
 - MSISDN as a SIP-URI: e.g. sip:+447700900123@example.com;user=phone
 - MSISDN as Tel-URI: e.g. tel:+447700900123
- The IMS Private User Identity as an NAI: e.g. username@realm
- P-Access-Network-Info with:-
 - access-type= 3GPP-E-UTRAN-FDD or 3GPP-E-UTRAN-TDD
 - UTRAN-cell-id-3gpp parameter
- Request-URI set to the SIP-URI of the domain name of the home network
- Related headers for IMS AKA parameters

The P-CSCF receives the SIP REGISTER request from the UE and inserts:

- Path header with a SIP-URI identifying the P-CSCF for routing
- P-Charging-Vector header with the icid-value
- P-Visited-Network-ID to identify the P-CSCF's network domain

Then P-CSCF forwards the request to the I-CSCF.

The I-CSCF queries the HSS using the User Authorization Request (**UAR**) for authorization and obtaining the S-CSCF name for the Public User Identity.

The HSS validates that the Public User Identity and Private User Identity are valid and not barred (**UAA**).

Once the S-CSCF is identified, the I-CSCF forwards the SIP REGISTER request to the S-CSCF.

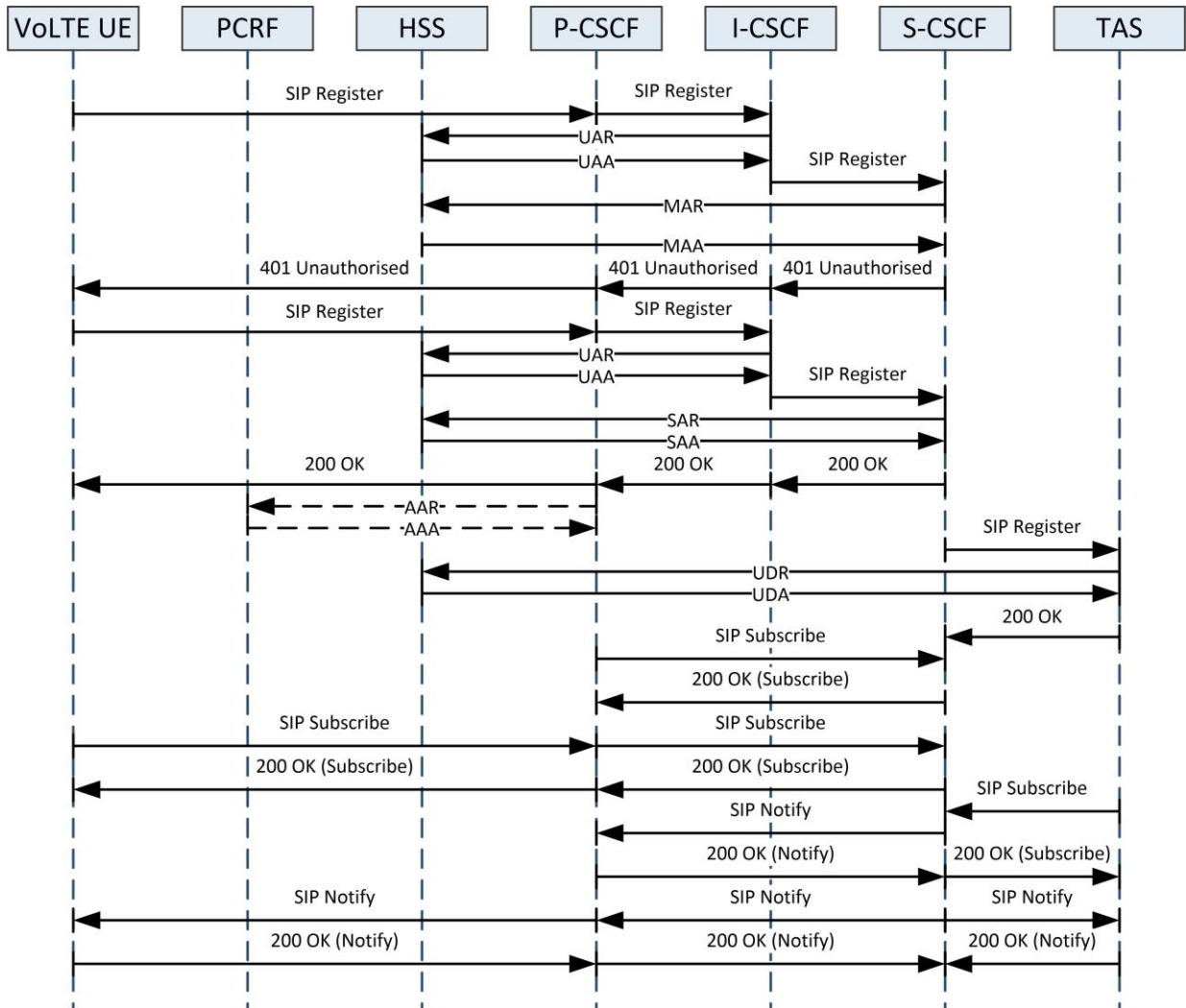

Figure 5.2 VoLTE UE registration to IMS message sequence

The S-CSCF initiates a Multimedia Authentication Request to the HSS to retrieve the authentication vectors to perform IMS-AKA security. The HSS stores the related S-CSCF name for the Public User Identity being registered and returns the authentication vectors to the S-CSCF.

Upon receipt of the IMS AKA authentication vectors, the S-CSCF stores the XRES and replies to the SIP REGISTER request with a 401 “Unauthorized” response indicating that AKA_{v1}-MD5 is the security mechanism to be used. The RAND and AUTN parameters, Integrity Key and Cipher Key are also included.

The P-CSCF removes the Cipher Key and Integrity Key from the 401 “Unauthorized” response and binds these to the Private User Identity with a set of temporary security associations for the result of the challenge.

The P-CSCF then forwards the response to the UE.

The UE extracts the RAND and AUTN parameters, calculates the RES, and derives the Cipher Key and Integrity Key from the RAND. The UE creates a temporary set of security associations based on parameters received from the P-CSCF (IPSec), and sends a new REGISTER request to the P-CSCF with a populated Authorization header containing the RES indicating that the message is integrity protected.

The P-CSCF checks the temporary security associations, and verifies the security related information received from the UE. This P-CSCF forwards the SIP REGISTER request to the I-CSCF with the RES included.

The I-CSCF uses the User Authorization Request message to retrieve the S-CSCF name stored within the HSS, and forwards the request to the relevant S-CSCF.

The S-CSCF checks whether the RES received in the SIP REGISTER and the XRES previously stored match. The S-CSCF then performs the Server Assignment Request procedure to the HSS to download the relevant user profile and register the VoLTE UE. The S-CSCF stores the route header of the P-CSCF and binds this to the contact address of the VoLTE UE, this is used for routing to the VoLTE UE in future messages. Parameters of the P-Charging-Vector header are stored, and the S-CSCF sends a 200 OK response to the I-CSCF, including the user's display name (retrieved from the user profile in the HSS) within the P-Associated-URI, which forwards the message to the P-CSCF.

On receipt of the 200 OK from the I-CSCF, the P-CSCF changes the temporary set of security associations to a newly established set of security associations. It protects the 200 OK with these associations and sends the 200 OK to the VoLTE UE. All future messages sent to the UE will be protected using the security associations.

Optionally, the P-CSCF sends an AAR message to the PCRF to perform application binding to the default bearer (i.e. the P-CSCF is requesting to be informed in the event of the default bearer being lost/disconnected in order to trigger an IMS de-registration). The PCRF performs the binding and responds with a AAA message to the P-CSCF. Note that if this message is not sent, then IMS relies on other mechanisms to detect loss of the underlying default bearer, i.e., loss of connectivity (e.g. timeouts on trying to signal to the UE for an incoming call or the UE registers in the IMS with a new IP address).

On receipt of the 200 OK, the UE changes the temporary security association to a newly established set of security associations that will be used for further messages to the P-CSCF.

The VoLTE UE is now registered with the IMS network for VoLTE services, with SIP signalling being transported over the default EPC bearer.

The S-CSCF sends a third party SIP REGISTER to the VoLTE AS, as configured in the initial filter criteria (iFC) within the subscriber profile. The TAS may use the User Data Request procedure to read VoLTE data stored in the HSS.

The VoLTE UE, P-CSCF and TAS shall subscribe to the registration event package using the SIP SUBSCRIBE message, in order to be notified on any change of registration state for the public user identity. In turn, the S-CSCF shall send a SIP NOTIFY to the subscribing entities informing them of the active registration status.

5.2 Basic VoLTE UE to VoLTE UE Voice Call Establishment

5.2.1 Originating Side

A VoLTE UE, shall perform call establishment by using the IMS network. The IMS Signalling shall be sent over the default bearer, and a new dedicated bearer shall be dynamically established for the voice traffic.

When a VoLTE UE originates a voice call from LTE, it executes the normal mobile origination procedure.

The VoLTE UE initiates a SIP INVITE request, containing the SDP offer with IMS media capabilities. The SDP offer shall contain the AMR Narrowband codec, and it is recommended that the AMR Wideband codec is included to provide support for HD Voice and shall indicate that local preconditions for QoS are desired but not yet met, using the segmented status type. That the media stream is set to inactive. The desired QOS for the remote end are set to “none” as the originating UE is unaware of the QOS requirements at the terminating side. The request is sent to the P-CSCF that was discovered during the registration procedure. The INVITE request contains:

- 1) Within the Contact header and the P-Preferred-Service header, the IMS Communication Service Identifier's (ICSI) for IMS Multimedia Telephony:
 - urn:urn-7:3gpp-service.ims.icsi.mmtel
- 2) The IMS Public User Identity of the calling-party in one of the forms below:
 - Alphanumeric SIP-URI: e.g. user@example.com
 - MSISDN as a SIP-URI: e.g. sip:+447700900123@example.com;user=phone
 - MSISDN as Tel-URI: e.g. tel:+447700900123
- 3) P-Access-Network-Info with:
 - Access-type= 3GPP-E-UTRAN-FDD or 3GPP-E-UTRAN-TDD
 - UTRAN-cell-id-3gpp parameter
- 4) Request-URI set to the SIP-URI or tel-URI of the called-party.

The P-CSCF adds the P-Charging-Vector header and forwards the SIP INVITE to the S-CSCF that was identified during the registration process.

If an IMS-ALG/AGW is deployed, then the P-CSCF will also invoke the IMS-AGW over the Iq reference point to provide appropriate resources in the media plane.

The P-CSCF forwards the SIP INVITE to the S-CSCF. The offered SDP address shall reflect the media pin-hole created in the IMS-AGW if applicable.

The S-CSCF receives the SIP INVITE from the P-CSCF, and invokes any VoLTE services as triggered by the initial filter criteria within the subscriber profile that was received during the IMS Registration.

The S-CSCF checks the P-Preferred-Service header in the SIP INVITE (e.g. MMTel ICSI) and verifies that the user is authorized for the service by validating against the subscribed services that were retrieved in the service profile during IMS Registration (Core Network Service Authorization – Service ID).

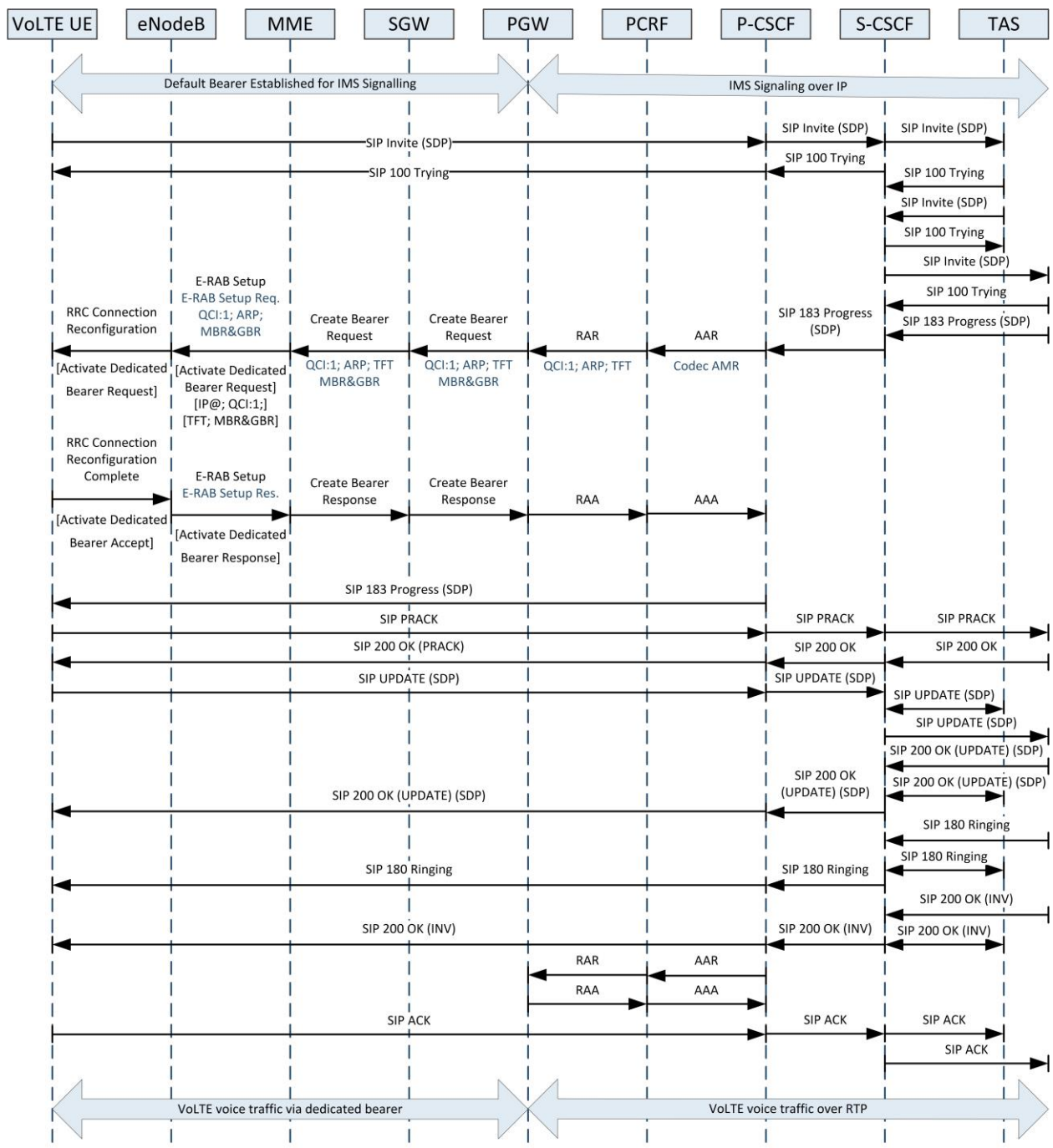

Figure 5.3 Basic VoLTE UE to VoLTE UE Voice Call Establishment - Originating Side message sequence

If the MMTel ICSI is not in the subscribed services, the INVITE request shall be rejected (403 Forbidden). If validated, the S-CSCF then adds the ICSI into the P-Asserted-Service header, and removes the P-Preferred-Service header.

Due to service logic within the user profile, and the identification of the call as a VoLTE call (i.e. MMTel ICSI), the S-CSCF shall route the SIP INVITE to the TAS at this point to invoke VoLTE

supplementary services. The TAS invokes any supplementary service logic and routes the SIP INVITE to the S-CSCF.

The S-CSCF determines that the Called-Party is within the home network (i.e. ENUM/DNS lookup/internal configuration) and routes the SIP INVITE to the I-CSCF to determine the terminating S-CSCF of the Called-Party.

The called party's VoLTE UE will return an SDP answer in a SIP 183 Progress message. The SDP answer should contain only one codec and indicates that preconditions are also desired but not yet met at the terminating end and that a confirmation should be sent when QoS preconditions have been met at the originating side and that the media stream is inactive. This message is received by the S-CSCF and forwarded to the P-CSCF.

The P-CSCF uses the SDP answer to configure the IMS-AGW if deployed.

In addition, the P-CSCF analyses the SDP in the SDP Answer and sends the Authorize/Authenticate-Request message to the PCRF with the related service information (IP address, port numbers, information on media-type).

The PCRF authorizes the request and associates the service information with the stored subscription related information containing the information about the allowed service(s), QoS information and PCC Rules information. The PCRF identifies the affected IP-CAN session (e.g. default bearer) that has been established during the LTE Attach procedure, and initiates a Re-Authentication Request to the PGW to initiate the creation of a dedicated bearer for voice with the related QoS parameters (QCI=1, ARP) and the related traffic flow template. The PCRF must also subscribe to modifications related to the dedicated bearer in the PGW (e.g. INDICATION_OF_RELEASE_OF_BEARER).

The PGW acknowledges the Re- Authentication Request to the PCRF, which then acknowledges the Authorize/Authenticate-Request message sent from the P-CSCF. At this point, the IMS SIP session and the dedicated bearer used for voice are bounded together via PCC.

The PGW sends the Create Bearer Request to the SGW to create the dedicated bearer for VoLTE media. This message contains the dedicated bearer identity, Linked Bearer Identity to identify the associated default bearer, the traffic flow template, and the associated QoS parameters (QCI=1, ARP, GBR and MBR). The SGW sends the request to the MME.

The MME sends a Bearer Setup Request message to the eNodeB with the dedicated bearer identity, Linked Bearer Identity, the traffic flow template, and the associated QoS parameters in order to activate the dedicated bearer for voice traffic.

The eNodeB maps the QoS parameters to those required for the radio bearer, and then signals a RRC Connection Reconfiguration to the UE.

The UE stores the dedicated bearer identity and links the dedicated bearer to the default bearer indicated by the Linked EPS Bearer Identity. The UE binds the TFT and associated QoS parameters to the dedicated bearer, and acknowledges the request to the eNodeB, which then acknowledges the Bearer Request Setup to the MME.

The MME sends the Create Bearer Response message to the SGW to acknowledge the bearer activation. The message includes the dedicated bearer identity and User Location Information (ECGI) and forward to the PGW.

The P-CSCF forwards the SIP 183 Progress response to the VoLTE UE. This message shall also utilize 100rel and the originating UE shall generate a PRACK which is transited to the terminating side of the call with an associated 200 OK (PRACK) being received.

The VoLTE UE shall reserve internal resources to reflect the SDP answer and shall confirm resource reservation by sending a SIP UPDATE message with a new SDP Offer confirming the selected codec, that local preconditions have been met at the originating end (due to the establishment of the dedicated bearer) and that the media stream is now set to active.

The UPDATE message is forwarded via the P-CSCF and S-CSCF to the terminating leg of the call. Note that if the SDP Answer in the 183 Progress message contained more than one voice codec, then the UE would ensure only a single codec from that multiple list was included in the new Offer in the UPDATE message.

The 200 OK (UPDATE) response is received from the terminating leg of the call containing the SDP answer containing a single voice codec and confirming that preconditions are also met at the terminating side and that the media stream is active. This message is passed onto the originating UE via the S-CSCF and P-CSCF.

As preconditions have been met, the terminating UE is now alerted and shall send a SIP 180 (Ringing) response that is received by the S-CSCF and onto the P-CSCF and originating UE.

The P-Early-Media header is not present in the SIP 180 Ringing message and so the UE will generate local ring tone to the subscriber. This message shall not utilize 100rel as there is no SDP within the message.

When the called party's VoLTE UE has answered the call, it sends a 200 OK to the calling party VoLTE UE. This is received by the S-CSCF and forwarded to the P-CSCF. The P-CSCF invokes the PCRF with an AAA message to enable both the uplink and downlink of the dedicated bearer.

In turn the PCRF invokes the P-GW with a RAR message to enable the media flows at the P-GW.

The P-CSCF (IMS-ALG) invokes the IMS-AGW (if deployed) to ensure that duplex media can be conveyed via IMS-AGW at this point.

The P-CSCF forwards the SIP 200 OK (INVITE) to the VoLTE UE.

The VoLTE UE receives the 200 OK, and sends a SIP ACK message to acknowledge that the call has been established.

At this stage, the VoLTE UE has a call established with voice traffic sent over the dedicated bearer and via the IMS-AGW. The IMS signaling is sent over the default bearer. (2)

5.2.2 Terminating Side

A VoLTE UE shall receive a call via IMS network. The IMS signaling shall be sent over the default bearer, and the network establish a new dedicated bearer for the voice traffic.

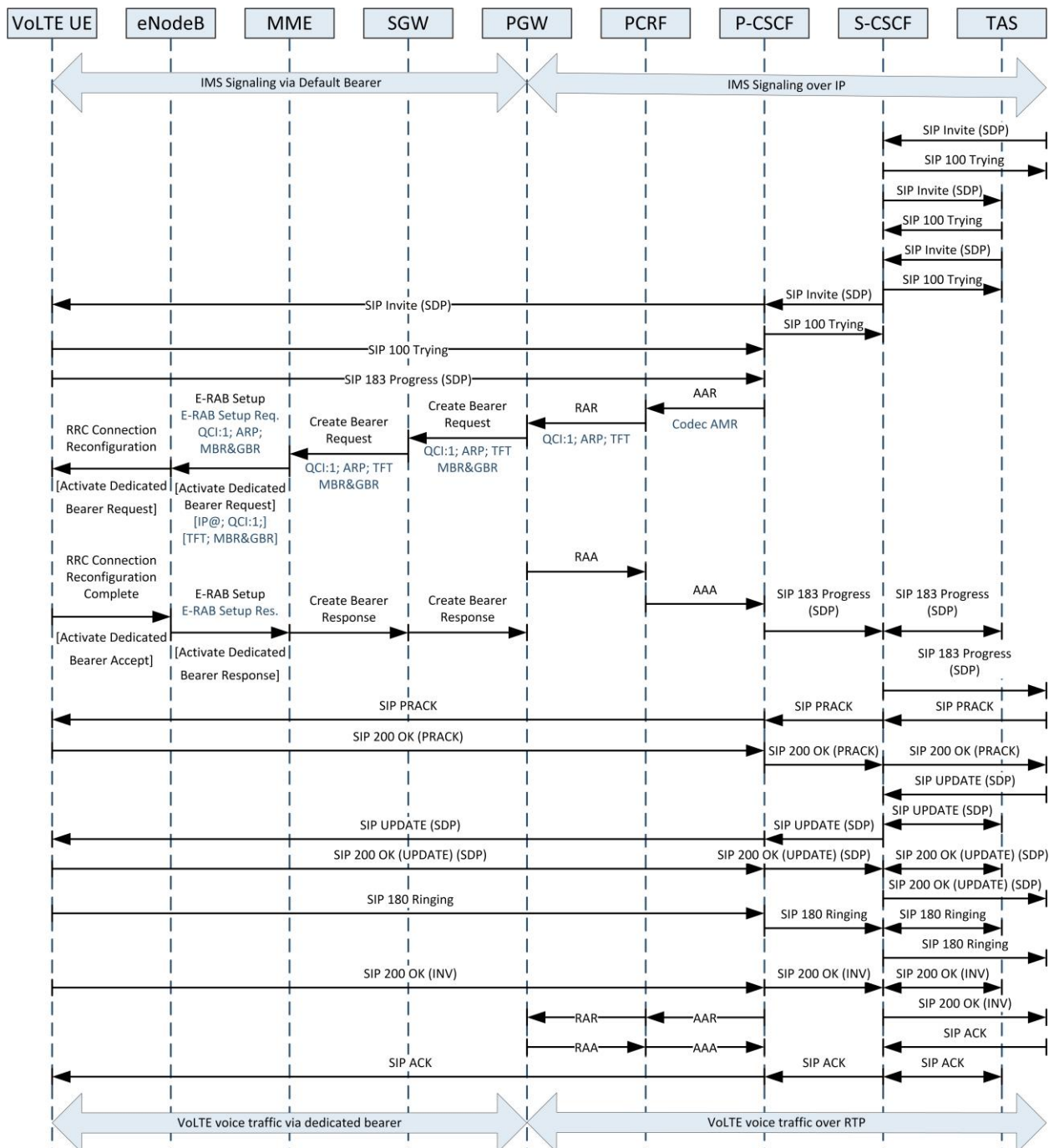

Figure 5.4 VoLTE UE to VoLTE UE Voice Call Establishment – Terminating Side message sequence

The S-CSCF receives a SIP INVITE containing an SDP offer. The SDP offer shall contain the AMR Narrowband codec, and optionally the AMR Wideband codec. The SDP indicates that preconditions are applicable and that QOS preconditions are desired but not yet reserved at the originating side. The media stream is set to inactive.

The S-CSCF invokes any VoLTE services as triggered by the initial filter criteria within the subscriber profile that was received during the IMS Registration. The S-CSCF shall route the SIP INVITE to the TAS at this point to invoke VoLTE supplementary services. The TAS invokes any supplementary service logic and routes the SIP INVITE to the S-CSCF. The S-CSCF routes the SIP INVITE to the terminating P-CSCF that was associated to the subscriber during IMS registration.

If an IMS-ALG/AGW is deployed, then the P-CSCF (IMS-ALG) invokes the IMS-AGW to reserve resources for the media connection. In this event, the SDP address in the INVITE is over-written to reflect the media pin-hole created on the IMS-AGW.

The P-CSCF forwards the SIP INVITE to the VoLTE UE.

When the VoLTE UE receives the SIP INVITE it shall allocate resources for the call and select one voice codec from the SDP offer. The UE shall send a SIP 183 Progress response containing the SDP Answer. The message shall indicate that 100rel is required. The SDP Answer indicates that QoS preconditions are desired but not yet met at the terminating side of the call. In addition, the SDP shall indicate that the originating side should confirm when its local QoS preconditions have been met.

On receipt of the SIP 183 Progress message, the P-CSCF updates the IMS-AGW if applicable with the SDP answer from the UE and sends the Authorize/Authenticate-Request message to the PCRF with the related updated service information (IP address, port numbers, information on media-type).

The PCRF authorizes the request and associates the service information to the stored subscription related information containing the information about the allowed service(s), QoS information and PCC Rules information. The PCRF identifies the affected IP-CAN session that has been established during the LTE Attach procedure, and initiates a Re-authentication request to the PGW to initiate the creation of a dedicated bearer for voice with the related QoS parameters (QCI=1, ARP) and the related traffic flow template. The PCRF shall also subscribe to modifications related to the dedicated bearer in the PGW (e.g. LOSS_OF_BEARER, INDICATION_OF_RELEASE_OF_BEARER).

The PGW acknowledges the Re- Authentication Request to the PCRF, which then acknowledges the Authorize/Authenticate-Request message sent from the P-CSCF. At this point the IMS SIP session and the dedicated bearer used for voice are bound together via PCC.

The PGW sends the Create Bearer Request to the SGW to create the dedicated bearer for VoLTE media. This message contains the dedicated bearer identity, Linked Bearer Identity to identify the associated default bearer, the traffic flow template, and the associated QoS parameters (QCI=1, ARP, GBR and MBR), etc. The SGW sends the request to the MME.

The MME sends a Bearer Setup Request message to the eNodeB with the dedicated bearer identity, Linked Bearer Identity, the traffic flow template, and the associated QoS parameters in order to activate the dedicated bearer for voice traffic.

The eNodeB maps the QoS parameters to those required for the radio bearer, and then signals a RRC Connection Reconfiguration to the UE. The UE stores the dedicated bearer identity and links the dedicated bearer to the default bearer indicated by the Linked EPS Bearer Identity. The UE binds the TFT and associated QoS parameters to the dedicated bearer, and

acknowledges the request to the eNodeB, which then acknowledges the Bearer Request Setup to the MME.

The MME sends the Create Bearer Response message to the SGW to acknowledge the bearer activation. The message includes the dedicated bearer identity and User Location Information (ECGI). This is then forwarded to the PGW.

On receipt of the AAA response from the PCRF, the P-CSCF will convey the SIP 183 Progress (SDP) message to the S-CSCF. The contained SDP reflects the address of the media pin hole in the IMS-AGW if applicable.

The PRACK message is transited from the originating side of the call.

The terminating side sends a 200 OK (PRACK) in response to the PRACK.

A second SDP Offer is now received from the originating leg of the call in a SIP UPDATE message indicating that preconditions have been met at the originating side and that the media stream is active.

The UPDATE is passed to the UE via the S-CSCF and P-CSCF. The UE sends a 200 OK (UPDATE) response containing a SDP Answer confirming that QOS preconditions are also satisfied at the terminating side (due to the establishment of the dedicated bearer) and that the media stream is active. The 200 OK (UPDATE) message is sent to the originating leg of the call via the P-CSCF and S-CSCF.

As preconditions are now met at both ends, the UE will alert the user and send a SIP 180 Ringing response. This message does not contain SDP and so will not utilize 100rel. The P-Early-Media header is not present in this message.

The SIP 180 Ringing response is sent to the originating leg via the P-CSCF and S-CSCF.

When the call is answered, the VoLTE UE shall send a SIP 200 OK (INVITE) message to the P-CSCF.

The P-CSCF invokes the PCRF with an AAA message to enable both the uplink and downlink of the dedicated bearer to reflect the SDP exchange. In turn the PCRF invokes the P-GW with a RAR message to enable the media flows at the P-GW.

The P-CSCF (IMS-ALG) shall also invoke the IMS-AGW to if applicable ensure that duplex media can traverse the IMS-AGW.

The 200 OK is forwarded to the S-CSCF and then to the originating side of the call.

At this stage, the VoLTE UE has a call established with voice traffic sent over the dedicated bearer via the IMS-AGW. The IMS Signalling is sent over the default bearer. (2)

5.3 Basic VoLTE UE to VoLTE UE Voice Call Clearing

A VoLTE UE shall perform call clearing by using the IMS network. The IMS Signalling shall be sent over the default bearer, and the dedicated bearer that was dynamically established for the voice traffic shall be removed.

5.3.1 Initiated side

The VoLTE UE sends a SIP BYE message to the P-CSCF. If applicable, the P-CSCF (IMS-ALG) releases the resources in the IMS-AGW.

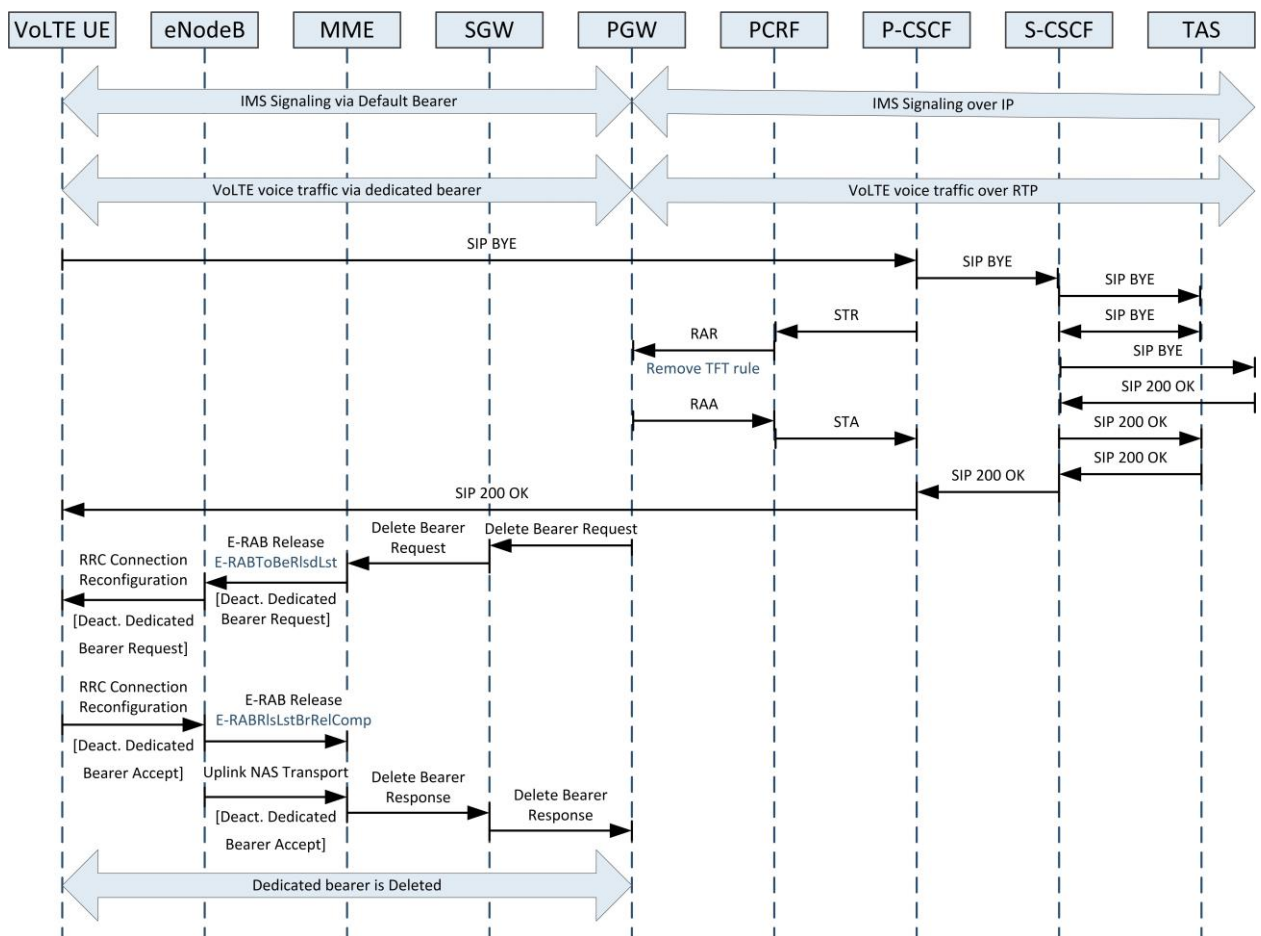

Figure 5.5 Basic VoLTE UE to VoLTE UE Voice Call Clearing – Initiated message sequence

The P-CSCF also initiates a Session Termination Request to the PCRF to initiate the process of removing the dedicated bearer that was established for the voice traffic. The PCRF removes the binding between the stored subscription information and the IMS service information, and initiates a Re-Authentication Request to the PGW to remove the dedicated bearer for voice with the related QoS parameters (QCI=1, ARP) and the related traffic flow template.

The Delete Bearer Request, Bearer Release Request, and RRC Reconfiguration Request are utilized to remove the dedicated bearer utilized for voice traffic.

The P-CSCF forwards the SIP BYE message to the S-CSCF which may invoke any VoLTE service logic as triggered by the initial filter criteria within the subscriber profile that was received during the IMS Registration. The S-CSCF shall forward the SIP BYE to the TAS at this point where VoLTE supplementary services may have been invoked. The S-CSCF routes the SIP BYE to the S-CSCF of the other party. The other party acknowledges the SIP BYE with a 200 OK.

At this stage, the VoLTE UE has cleared the call and the dedicated bearer for voice traffic has been removed. (2)

5.3.2 Received side

A VoLTE UE shall perform call clearing by using the IMS network. The IMS signaling shall be sent over the default bearer, and the dedicated bearer that was dynamically established for the voice traffic shall be removed.

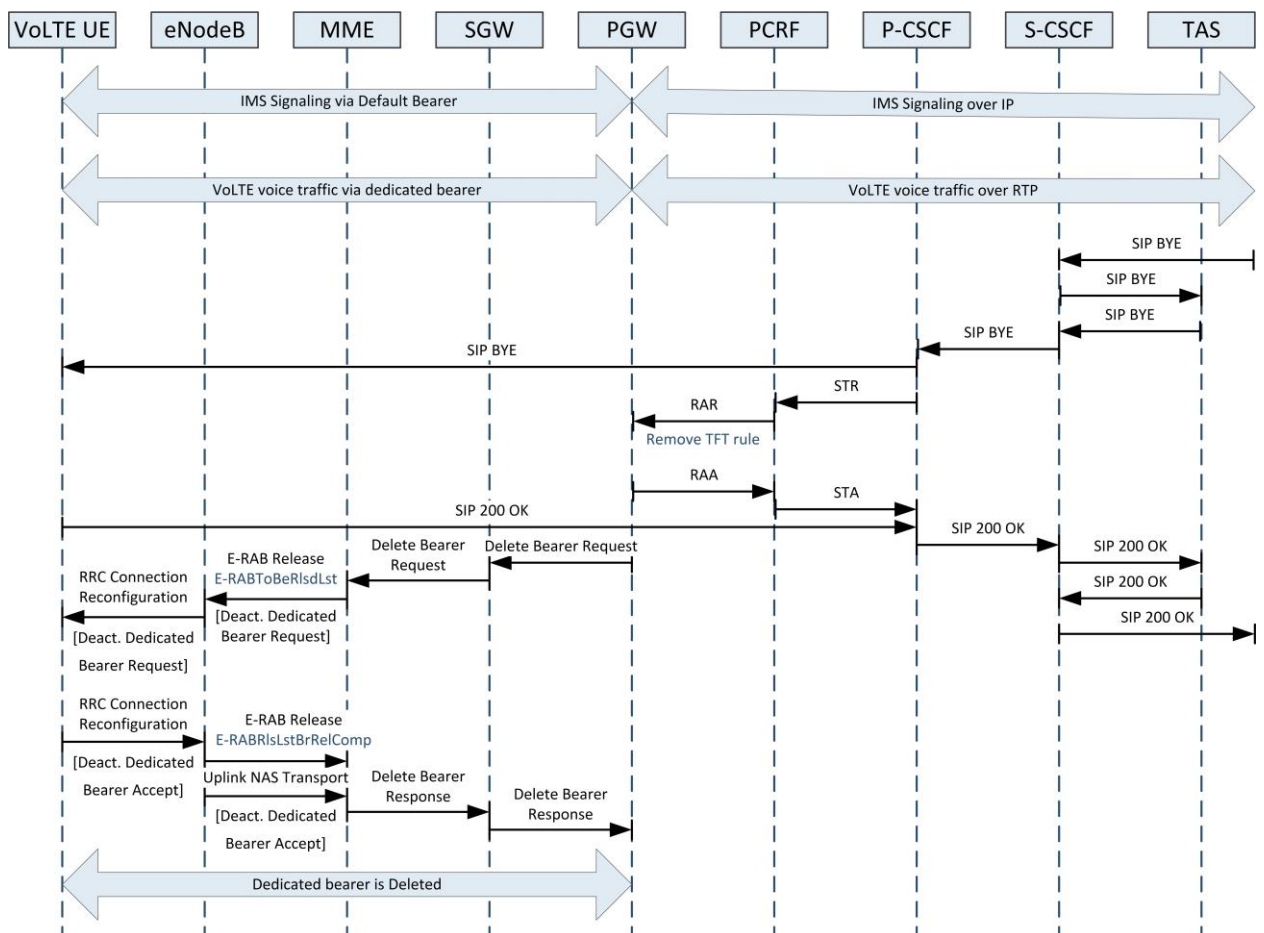

Figure 5.6 Basic VoLTE UE to VoLTE Voice Call Clearing – Received message sequence

A SIP BYE is received by the S-CSCF from the other party. The S-CSCF shall forward the SIP BYE to the TAS at this point where VoLTE supplementary services may have been invoked. The S-CSCF routes the SIP BYE to the P-CSCF which in turn forwards to the VoLTE UE. The VoLTE UE acknowledges the call clearing by sending a 200 OK.

On receiving the SIP BYE, the P-CSCF (IMS-ALG) frees off the media resources in the IMS-AGW if applicable. The P-CSCF also initiates a Session Termination Request to the PCRF to initiate the process of removing the dedicated bearer that was established for the voice traffic.

The PCRF removes the binding between the stored subscription information and the IMS service information, and initiates a Re-Auth-Request to the PGW to remove the dedicated bearer for voice with the related QoS parameters (QCI=1, ARP) and the related traffic flow template.

The Delete Bearer Request, Bearer Release Request, and RRC Reconfiguration Request are utilised to remove the dedicated bearer utilised for voice traffic.

At this stage, the VoLTE UE has cleared the call and the dedicated bearer for voice traffic has been removed. (2)

6 Tests on LTE network

6.1 EPC attach UE – eNodeB - MME

Communication is captured during the LTE UE attach. This request is received UE attach request between eNodeB and MME (S1AP protocol). Full protocol is in Appendix 1.

```
Frame 72: 190 bytes on wire (1520 bits), 190 bytes captured (1520 bits) on interface0
Ethernet II, Src: HuaweiTe_7f:54:2e (7c:60:97:7f:54:2e), Dst: HuaweiTe_89:03:9b (d8:49:0b:89:03:9b)
Internet Protocol Version 4, Src: 172.30.31.100, Dst: 172.30.16.1
```

The next parts of protocol will be changed in VoLTE.

1. EPS Attach Type:

```
.... .010 = EPS attach type: Combined EPS/IMSI attach (2)
```

2. NAS key set identifier

```
.001 .... = NAS key set identifier: (1)
```

3. UE network capability

```
UE network capability
Length: 2
1... .... = EEA0: Supported
.1.. .... = 128-EEA1: Supported
..1. .... = 128-EEA2: Supported
...0 .... = 128-EEA3: Not Supported
.... 0... = EEA4: Not Supported
.... .0.. = EEA5: Not Supported
.... ..0. = EEA6: Not Supported
.... ...0 = EEA7: Not Supported
0... .... = EIA0: Not Supported
.1.. .... = 128-EIA1: Supported
..1. .... = 128-EIA2: Supported
...0 .... = 128-EIA3: Not Supported
.... 0... = EIA4: Not Supported
.... .0.. = EIA5: Not Supported
.... ..0. = EIA6: Not Supported
.... ...0 = EIA7: Not Supported
```

4. DRX parameters

```
DRX Parameter
Element ID: 0x5c
SPLIT PG CYCLE CODE: 10 (10)
0000 .... = CN Specific DRX cycle
length coefficient: CN Specific DRX cycle length coefficient / value not specified
by the MS (0)
.... 0... = SPLIT on CCCH: Split pg
cycle on CCCH is not supported by the mobile station
.... .000 = Non-DRX timer: no non-DRX
mode after transfer state (0)
```

5. Voice Domain Preference and UE's Usage Setting (indicating support of IMS voice):

```
.... ..00 = Voice domain preference for E-UTRAN: CS Voice only (0)
```

6. ESM message container

```
ESM message container
Length: 33
ESM message container contents: 0204d011d1271a8080211001000010810600000000830600
```

7. TAI+ECGI location information of the cell where it received the message.

```
Item 2: id-TAI
ProtocolIE-Field
id: id-TAI (67)
criticality: reject (0)
value
    TAI
        pLMNidentity: 32f094
        Mobile Country Code (MCC): Czech Rep. (230)
        Mobile Network Code (MNC): Unknown (49)
        tAC: 0001 (1)
Item 3: id-EUTRAN-CGI
ProtocolIE-Field
id: id-EUTRAN-CGI (100)
criticality: ignore (1)
value
    EUTRAN-CGI
```

Wireshark filter was used to clear capture:

```
not gtp and not tcp and not icmp and ip.addr == 172.30.20.4 or ip.addr ==
172.30.20.5 or ip.addr == 172.30.20.6 or ip.addr == 172.30.31.100 or
ip.addr == 172.30.31.200 or ip.addr == 172.30.16.17 or ip.addr == 172.30.16.134 or
ip.addr ==
172.30.16.133 or ip.addr == 172.30.16.137 or ip.addr == 172.30.16.33 or ip.addr ==
172.30.16.34 or
ip.addr == 172.30.16.1 or ip.addr == 172.30.16.3
```

Full attach communication in Appendix2.

7 VoLTE implementation analyze and solution

For VoLTE support, I need to reconfigure EPC, IMS and update the UE's software (if supported). Because of other test and experiments with newly 4G network in facility, I found another way.

1. Found the full supporting VoLTE service IMS.
2. Install the all needed functions in IMS, base configuration.
3. Configure both EPC and new IMS for working together.
4. Implement VoLTE service

This way help to avoid the changes in working IMS, it would looks like the EPC hire by the another provider. In addition, it would help students to working with the 4G network in future. Here is the key point to design the laboratory exercise.

7.1 IMS install

At this step I analyses the existing open source IMS projects, and choose the Kamailio IMS and FHOSS HSS. Kamailio is support VoLTE, Linux-based open source free IMS.

SEMS - is a free, high performance, extensible media server for SIP based VoIP services. It would be the TAS (Telephony Application Server)

For the start I try to install Kamailio IMS to the Ubuntu 14.04 on VMware. Here is my step by step solution:

- 1) Add ng-voice.com key and repository and update:

```
wget -O - http://repository.ng-voice.com/PublicKey | apt-key add -  
echo "deb http://repository.ng-voice.com wheezy ims rtpproxy fhooss sems" >  
/etc/apt/sources.list.d/kamailio-ims.list  
apt-get update
```

- 2) Next installing software, required for FHOSS: Oracle Java: for MySQL server and MySQL server: for database
- 3) SEMS install:

```
apt-get install sems
```

- 4) Kamailio IMS install:

```
apt-get install kamailio kamailio-ims-modules kamailio-presence-modules kamailio-  
tls-modules kamailio-mysql-modules kamailio-xmlrpc-modules
```

- 5) NGCP-rtppengine - This is a module that enables media streams to be proxied via an RTP proxy.

```
apt-get install ngcp-rtppengine
```

6) FHOSS install. During installation process, dialog boxes would be opened.

```
apt-get install opnimscore-fhoss
```

For the future work may be installed the next programs and modules:

- `ngrep` strives to provide most of GNU `grep`'s common features, applying them to the network layer. `ngrep` is a `pcap`-aware tool that will allow you to specify extended regular or hexadecimal expressions to match against data payloads of packets.

```
apt-get install ngrep
```

- `TCPDUMP`

```
apt-get install tcpdump
```

- `Libevent` is an asynchronous event notification library that provides a mechanism to execute a callback function when a specific event occurs on a file descriptor or after a timeout has been reached.

```
apt-get install libevent-2.0-5  
apt-get install libevent-pthreads-2.0-5  
apt-get install libspandsp2
```

FHOSS may be configured by web interface on port 8080. The default username/Password combination of `hssAdmin/hss`.

DNS server is needed. For example the P-CSCF will do a NAPTR/SRV query to find the I-CSCF and only a true DNS server will be able to solve this. For example of basic IMS configuration are used configuration files from "Kamailio World 2015" workshop - "Kamailio for Building IMS Core Platforms and VoLTE".

8 Conclusion

The target of this project is collecting knowledge about VoLTE service implementation. Theoretical part of thesis images the key requirements of the fourth generation network evolved packet core to working together with IP multimedia subsystem, the changes are covered all components of network. Within some new functionality in facility EPC is impossible to implement VoLTE, for example AMR codec license is needed for voice traffic in EPC.

For the future work with LTE IMS redundancy is needed for parallel testing new Phase 3 implementation services or for student education work. Kamailio IMS can solve the task of VoLTE service implementation. This free open source IMS supports many VoLTE services and is quickly developed. Configuration templates for IMS functions are in free access.

During the project solution IMS was installed on Linux KVM, studied the theory on this sphere and materials was prepared to the future propose laboratory exercise for MKPM.

The capture of UE registration to eNodeB was image the attach protocol flow, and protocol analyze was represent the protocols parts, that will be changed in phase 3 implementation.

Additional, LTE RAN tests by Rohde & Schwarz R&S TMSW ROMES4 was image the RAN bandwidths of facility is LTE 700 MHz (band 17) and 2600 MHz (band 7).

VoLTE implementation is complicated problem. Knowledge or experience that I took during the trying to solve all issues, would help me in future in this field. This thesis is more theoretical, then practical. To solve this problem project needs to cooperate more people and facility resources.

9 Literature

1. **3GPP**. Features and Study Items. *The 3rd Generation Partnership Project*. [Online] <http://www.3gpp.org/DynaReport/FeatureListFrameSet.htm>.
2. **GSM Association**. VoLTE Service Description and Implementation Guidelines Version 2.0. <http://www.gsma.com/>. [Online] October 7, 2014. <http://www.gsma.com/network2020/wp-content/uploads/2014/10/FCM.01-VoLTE-Service-Description-and-Implementation-Guidelines-Version-2.0.pdf>.
3. **Association, GSM**. LTE Roaming Guidelines Version 9.0. www.gsma.com. [Online] January 24, 2013. <http://www.gsma.com/newsroom/wp-content/uploads/2013/04/IR.88-v9.0.pdf>.
4. **Frédéric Firmin, 3GPP MCC**. NAS. Overview of the Non-Access Stratum. <http://www.3gpp.org/>. [Online] <http://www.3gpp.org/technologies/keywords-acronyms/96-nas>.
5. **3GPP**. S1 Application Protocol (S1AP) 3GPP TS 36.413 version 12.3.0 Release 12. www.etsi.org. [Online] http://www.etsi.org/deliver/etsi_ts/136400_136499/136413/12.03.00_60/ts_136413v120300p.pdf.
6. —. IP Multimedia Subsystem (IMS) Stage 2 3GPP TS 23.228 version 13.5.0 Release 13. www.3gpp.org. [Online] april 2016. http://www.etsi.org/deliver/etsi_ts/123200_123299/123228/13.05.00_60/ts_123228v130500p.pdf.
7. **J. Rosenberg, H. Schulzrinne, G. Camarillo, A. Johnston, J. Peterson, R. Sparks, M. Handley, E. Schooler**. RFC3261 SIP: Session Initiation Protocol. tools.ietf.org. [Online] June 2002. <https://tools.ietf.org/html/rfc3261>.
8. **J. Rosenberg, H. Schulzrinne**. RFC3262 Reliability of Provisional Responses in the Session Initiation Protocol (SIP). tools.ietf.org. [Online] June 2002. <https://tools.ietf.org/html/rfc3262#section-5>.
9. **A. B. Roach**. RFC3265 Session Initiation Protocol (SIP)-Specific Event Notification. tools.ietf.org. [Online] June 2002. <https://tools.ietf.org/html/rfc3265>.
10. **A. Niemi**. RFC3903 Session Initiation Protocol (SIP) Extension for Event State Publication. tools.ietf.org. [Online] October 2004. <https://tools.ietf.org/html/rfc3903>.
11. **C. Holmberg, E. Burger, H. Kaplan**. RFC6086 Session Initiation Protocol (SIP) INFO Method and Package Framework. tools.ietf.org. [Online] January 2011. <https://tools.ietf.org/html/rfc6086>.
12. **R. Sparks**. RFC3515 The Session Initiation Protocol (SIP) Refer Method. tools.ietf.org. [Online] April 2003. <https://tools.ietf.org/html/rfc3515>.
13. **B. Campbell, J. Rosenberg, H. Schulzrinne, C. Huitema, D. Gurle**. RFC3428 Session Initiation Protocol (SIP) Extension for Instant Messaging. www.ietf.org. [Online] December 2002. <https://www.ietf.org/rfc/rfc3428.txt>.

14. **J. Rosenberg.** RFC3311 The Session Initiation Protocol (SIP) UPDATE Method. *tools.ietf.org*. [Online] September 2002. <https://tools.ietf.org/html/rfc3311>.
15. **SPIRENT.** IMS Procedures and Protocols. <http://www.spirent.com/>. [Online] 2014. http://www.spirent.com/~media/White%20Papers/Mobile/Protocol_Reference_Guide.pdf.
16. **H. Schulzrinne, S. Casner, R. Frederick, V. Jacobson.** RFC3550 RTP: A Transport Protocol for Real-Time Applications. *tools.ietf.org*. [Online] July 2003. <https://tools.ietf.org/pdf/rfc3550.pdf>.
17. **Association, GSM.** IMS Profile for Voice and SMS IR.92 Version 9.0. <http://www.gsma.com/>. [Online] April 8, 2015. <http://www.gsma.com/newsroom/wp-content/uploads/IR.92-v9.0.pdf>.
18. **RF Wireless World.** LTE Signalling Radio Bearer types-SRB0,SRB1,SRB2. <http://www.rfwireless-world.com/>. [Online] <http://www.rfwireless-world.com/Tutorials/LTE-signalling-radio-bearers.html>.
19. **4g-lte-world.** Quality of Service (QoS) in LTE. <http://4g-lte-world.blogspot.cz/>. [Online] January 2013. <http://4g-lte-world.blogspot.cz/2013/01/quality-of-service-qos-in-lte.html>.
20. **GSM Association: Dan Warren, Calum Dewar.** Understanding 5G: Perspectives on future technological advancements in mobile. <https://www.gsmaintelligence.com>. [Online] December 2014. <https://www.gsmaintelligence.com/research/?file=141208-5g.pdf&download>.
21. **3GPP.** IP multimedia call control protocol based on Session Initiation Protocol (SIP) and Session Description Protocol (SDP); 3GPP TS 24.229 version 13.5.1 Release 13. <http://www.3gpp.org/>. [Online] 05 2016. http://www.etsi.org/deliver/etsi_ts/124200_124299/124229/13.05.01_60/ts_124229v130501p.pdf.

10 Abbreviations

| | |
|---------|---|
| 3GPP | 3rd Generation Partnership Project |
| A-SBC | Access Session Border Controller |
| ACR | Anonymous Call Rejection |
| AMBR | Aggregate Maximum Bit Rate |
| AMR | Adaptive Multi-Rate |
| AMR-WB | Adaptive Multi-Rate Wideband |
| APN | Access Point Name |
| ARP | Allocation and Retention Priority |
| AS | Application Server |
| ATCF | Access Transfer Control Function |
| ATGW | Access Transfer Gateway |
| ATU-STI | Access Transfer Update – Session Transfer ID |
| AUTN | Authentication Token |
| AVP | Attribute Value Pair |
| BGCF | Border Gateway Control Function |
| BICC | Bearer Independent Call Control |
| CDIV | Communication Diversion |
| CDR | Charging Data Record |
| CN | Core Network |
| CONF | Conferencing |
| CS | Circuit Switched |
| CSCF | Call Server Control Function |
| CSFB | Circuit Switched Fall Back |
| DEA | Diameter Edge Agent |
| DL | DownLink |
| DNS | Domain Name System |
| DPI | Deep Packet Inspection |
| DRA | Diameter Relay Agent |
| DRX | Discontinuous Reception |
| DSCP | DiffServ Code Point |
| ECGI | E-UTRAN Cell Global Identifier |
| eKSI | E-UTRAN Key Set Identifier |
| ENUM | E.164 Number Mapping |
| EPC | Evolved Packet Core |
| EPS | Evolved Packet System |
| ERAB | E-UTRAN Radio Access Bearer |
| ESM | EPS Session Management |
| ETSI | European Telecommunications Standards Institute |
| E-UTRAN | Evolved Universal Terrestrial Access Network |
| FDD | Frequency Division Duplex |
| GAA | Generic Authentication Architecture |
| GBA | Generic Bootstrapping Architecture |
| GBR | Guaranteed Bit Rate |
| GPRS | General Packet Radio Service |
| GRX | GPRS Roaming eXchange |
| GSM | Global System for Mobile communications |

| | |
|---------|---|
| GTP | GPRS Tunnelling Protocol |
| HLR | Home Location Register |
| HPMN | Home Public Mobile Network |
| HSPA | High Speed Packet Access |
| HSS | Home Subscriber Server |
| HTTP | Hypertext Transfer Protocol |
| I-CSCF | Interrogating Call Session Control Function |
| I-SBC | Interconnect Session Border Controller |
| IBCF | Interconnection Border Control Function |
| ICID | IM CN subsystem charging identifier |
| ICS | IMS Centralised Services |
| ICSI | IMS Communication Service Identifier |
| IM | IP Multimedia |
| IM-GW | IP Media Gateway |
| IMEI | International Mobile Equipment Identity |
| IMS | IP Multimedia Subsystem |
| IMS-AKA | IMS Authentication and Key Agreement |
| IMS-AGW | IMS Access Gateway |
| IMS-ALG | IMS Application Level Gateway |
| IMSI | International Mobile Subscriber Identity |
| IOT | Interoperability Testing |
| IP | Internet Protocol |
| IP-CAN | IP-Connectivity Access Network |
| IPsec | IP Security |
| IPX | IP Packet Exchange |
| ISIM | IM Services Identity Module |
| ISUP | ISDN User Part |
| LBO | Local Breakout |
| LTE | Long Term Evolution |
| MAC | Medium Access Control |
| MBR | Maximum Bit Rate |
| MCC | Mobile Country Code |
| ME | Mobile Equipment |
| MGCF | Media Gateway Control Function |
| MME | Mobility Management Entity |
| MMS | Multimedia Messaging Service |
| MMTel | Multimedia Telephony |
| MNC | Mobile Network Code |
| MNO | Mobile Network Operator |
| MRF | Media Resource Function |
| MSC | Mobile Switching Centre |
| MSISDN | Mobile Subscriber ISDN Number |
| MSRP | Message Session Relay Protocol |
| MTU | Maximum Transmission Unit |
| MWI | Message Waiting Indicator |
| NAPTR | Name Authority Pointer |
| NAS | Non-Access Stratum |
| NAT | Network Address Translation |
| NNI | Network to Network Interface |

| | |
|---------|--|
| OIP | Originating Identification Presentation |
| OIR | Originating Identification Restriction |
| P-CSCF | Proxy Call Session Control Function |
| PCC | Policy and Charging Control |
| PCEF | Policy and Charging Enforcement Function |
| PCO | Protocol Configuration Options |
| PCRF | Policy Charging and Rules Function |
| PDN | Packet Data Network |
| PGW | Packet Data Network Gateway |
| PHB | Per Hop Behaviour |
| PLMN | Public Land Mobile Network |
| PMN | Public Mobile Network |
| PS | Packet Switched |
| QCI | QoS Class Identifier |
| QoS | Quality of Service |
| RAB | Radio Access Bearer |
| RAN | Radio Access Network |
| RAND | RANdOm number (used for authentication) |
| RAT | Radio Access Technology |
| RES | user RESponse (used in IMS-AKA) |
| RLC | Radio Link Control |
| RRC | Radio Resource Control |
| RTCP | RTP Control Protocol |
| RTP | Real-time Transport Protocol |
| S-CSCF | Serving Call Session Control Function |
| SAE | System Architecture Evolution |
| SBC | Session Border Controller |
| SCC AS | Service Centralization & Continuity AS |
| SCTP | Stream Control Transmission Protocol |
| SDP | Session Description Protocol |
| SEG | Security Gateway |
| SGW | Serving Gateway |
| SGSN | Serving GPRS Support Node |
| SIGCOMP | Signalling Compression |
| SIP | Session Initiation Protocol |
| SIP-I | SIP with encapsulated ISUP |
| SMS | Short Message Service |
| SON | Self-Organising Networks |
| SRTP | Secure RTP |
| SRVCC | Single Radio Voice Call Continuity |
| STN-SR | Session Transfer Number for SRVCC |
| TAS | Telephony Application Server |
| TAI | Tracking Area Identity |
| TCP | Transmission Control Protocol |
| TDD | Time Division Duplex |
| TDM | Time Division Multiplexing |
| TEID | Tunnel End Point Identifier |
| TFT | Traffic Flow Template |
| THP | Traffic Handling Priority |

| | |
|-------|--|
| TLS | Transport Layer Security |
| TIP | Terminating Identification Presentation |
| TIR | Terminating Identification Restriction |
| TrGW | Transition Gateway |
| TTM | Time To Market |
| UDC | User Data Convergence |
| UDP | User Datagram Protocol |
| UDR | User Data Repository |
| UE | User Equipment |
| UICC | Universal Integrated Circuit Card |
| UL | Uplink |
| ULI | User Location Information |
| UMTS | Universal Mobile Telecommunications System |
| UNI | User to Network Interface |
| URN | Uniform Resource Name |
| URI | Uniform Resource Identifier |
| USIM | Universal Subscriber Identity Module |
| UTRAN | Universal Terrestrial Access Network |
| VLR | Visitor Location Register |
| VoLTE | Voice over LTE |
| XRES | eXpected user RESponse (used in IMS-AKA) |

Appendices

| | | |
|-----------|-------|----|
| Appendix1 | | 58 |
| Appendix2 | | 60 |
| Appendix3 | | 61 |

Appendix 1. E-NodeB attach request protocols

```
Frame 72: 190 bytes on wire (1520 bits), 190 bytes captured (1520 bits) on interface 0
Ethernet II, Src: HuaweiTe_7f:54:2e (7c:60:97:7f:54:2e), Dst: HuaweiTe_89:03:9b (d8:49:0b:89:03:9b)
Internet Protocol Version 4, Src: 172.30.31.100, Dst: 172.30.16.1
  0100 .... = Version: 4
  .... 0101 = Header Length: 20 bytes
  Differentiated Services Field: 0xb8 (DSCP: EF PHB, ECN: Not-ECT)
  Total Length: 176
  Identification: 0x5a55 (23125)
  Flags: 0x00
  Fragment offset: 0
  Time to live: 254
  Protocol: SCTP (132)
  Header checksum: 0xd91a [validation disabled]
  Source: 172.30.31.100
  Destination: 172.30.16.1
  [Source GeoIP: Unknown]
  [Destination GeoIP: Unknown]
Stream Control Transmission Protocol, Src Port: 36412 (36412), Dst Port: 36412 (36412)
S1 Application Protocol
  S1AP-PDU: initiatingMessage (0)
    initiatingMessage
      procedureCode: id-initialUEMessage (12)
      criticality: ignore (1)
      value
        InitialUEMessage
          protocolIEs: 5 items
            Item 0: id-eNB-UE-S1AP-ID
              ProtocolIE-Field
                id: id-eNB-UE-S1AP-ID (8)
                criticality: reject (0)
                value
                  ENB-UE-S1AP-ID: 168444
            Item 1: id-NAS-PDU
              ProtocolIE-Field
                id: id-NAS-PDU (26)
                criticality: reject (0)
                value
                  NAS-PDU: 17c5e4d695830741120bf632f094800101c702001c02e060...
                  Non-Access-Stratum (NAS)PDU
                    0001 .... = Security header type: Integrity protected (1)
                    .... 0111 = Protocol discriminator: EPS mobility management messages (0x07)
                    Message authentication code: 0xc5e4d695
                    Sequence number: 131
                    0000 .... = Security header type: Plain NAS message, not security protected (0)
                    .... 0111 = Protocol discriminator: EPS mobility management messages (0x07)
                    NAS EPS Mobility Management Message Type: Attach request (0x41)
                    0... .... = Type of security context flag (TSC): Native security context (for KSIasme)
                    .001 .... = NAS key set identifier: (1)
                    .... 0... = Spare bit(s): 0x00
                    .... .010 = EPS attach type: Combined EPS/IMSI attach (2)
                  EPS mobile identity
                    Length: 11
                    .... 0... = odd/even indic: 0
                    .... .110 = Type of identity: GUTI (6)
                    Mobile Country Code (MCC): Czech Rep. (230)
                    Mobile Network Code (MNC): Unknown (49)
                    MME Group ID: 32769
                    MME Code: 1
                    M-TMSI: 0xc702001c
                  UE network capability
                    Length: 2
                    1... .... = EEA0: Supported
                    .1.. .... = 128-EEA1: Supported
                    ..1. .... = 128-EEA2: Supported
                    ...0 .... = 128-EEA3: Not Supported
                    .... 0... = EEA4: Not Supported
                    .... .0.. = EEA5: Not Supported
                    .... ..0. = EEA6: Not Supported
                    .... ...0 = EEA7: Not Supported
                    0... .... = EIA0: Not Supported
                    .1.. .... = 128-EIA1: Supported
                    ..1. .... = 128-EIA2: Supported
                    ...0 .... = 128-EIA3: Not Supported
                    .... 0... = EIA4: Not Supported
                    .... .0.. = EIA5: Not Supported
                    .... ..0. = EIA6: Not Supported
                    .... ...0 = EIA7: Not Supported
                  ESM message container
                    Length: 33
                    ESM message container contents: 0204d011d1271a8080211001000010810600000000830600...
                  Tracking area identity - Last visited registered TAI
                    Element ID: 0x52
                    Mobile Country Code (MCC): Czech Rep. (230)
                    Mobile Network Code (MNC): Unknown (49)
                    Tracking area code(TAC): 0x0001
                  DRX Parameter
                    Element ID: 0x5c
                    SPLIT PG CYCLE CODE: 10 (10)
                    0000 .... = CN Specific DRX cycle length coefficient: CN Specific DRX cycle length coefficient /
                    value not specified by the MS (0)
                    .... 0... = SPLIT on CCCH: Split pg cycle on CCCH is not supported by the mobile station
                    .... .000 = Non-DRX timer: no non-DRX mode after transfer state (0)
```

```

TMSI Status
1001 .... = Element ID: 0x9-
.... 000. = Spare bit(s): 0
.... ...0 = TMSI flag: no valid TMSI available
Mobile station classmark 2
Element ID: 0x11
Length: 3
0... .... = Spare: 0
..10. .... = Revision Level: Used by mobile stations supporting R99 or later versions of the
protocol (2)
...0 .... = ES IND: Controlled Early Classmark Sending option is not implemented in the MS
.... 1... = A5/1 algorithm supported: encryption algorithm A5/1 not available
.... .111 = RF Power Capability: RF Power capability is irrelevant in this information element
(7)
0... .... = Spare: 0
.0... .... = PS capability (pseudo-synchronization capability): PS capability not present
..01 .... = SS Screening Indicator: Capability of handling of ellipsis notation and phase 2 error
handling (1)
.... 1... = SM capability (MT SMS pt to pt capability): Mobile station supports mobile terminated
point to point SMS
.... .0.. = VBS notification reception: no VBS capability or no notifications wanted
.... ..0. = VGCS notification reception: no VGCS capability or no notifications wanted
.... ...0 = FC Frequency Capability: The MS does not support the E-GSM or R-GSM band
1... .... = CM3: The MS supports options that are indicated in classmark 3 IE
.0... .... = Spare: 0
..1. .... = LCS VA capability (LCS value added location request notification capability): LCS
value added location request notification capability supported
...0 .... = UCS2 treatment: the ME has a preference for the default alphabet
.... 0... = SoLSA: The ME does not support SoLSA
.... .1.. = CMSP: CM Service Prompt: Network initiated MO CM connection request supported for at
least one CM protocol
.... ..1. = A5/3 algorithm supported: encryption algorithm A5/3 available
.... ...0 = A5/2 algorithm supported: encryption algorithm A5/2 not available
Additional update type
1111 .... = Element ID: 0xf-
.... 000. = Spare bit(s): 0x00
.... ...1 = AUTV: SMS only (1)
Voice domain preference and UE's usage setting
Element ID: 0x5d
Length: 1
0000 0... = Spare bit(s): 0
.... .0.. = UE's usage setting: Voice centric
.... ..00 = Voice domain preference for E-UTRAN: CS Voice only (0)
GUTI type - Old GUTI type
1110 .... = Element ID: 0xe-
.... 000. = Spare bit(s): 0x00
.... ...0 = GUTI type: Native GUTI
Item 2: id-TAI
ProtocolIE-Field
id: id-TAI (67)
criticality: reject (0)
value
TAI
pLMNidentity: 32f094
Mobile Country Code (MCC): Czech Rep. (230)
Mobile Network Code (MNC): Unknown (49)
tAC: 0001 (1)
Item 3: id-EUTRAN-CGI
ProtocolIE-Field
id: id-EUTRAN-CGI (100)
criticality: ignore (1)
value
EUTRAN-CGI
Item 4: id-RRC-Establishment-Cause
ProtocolIE-Field
id: id-RRC-Establishment-Cause (134)
criticality: ignore (1)
value
RRC-Establishment-Cause: mo-Signalling (3)

```

Appendix 2. UE to E-NodeB attach request (E-NodeB – MME communication)

S1MME IP address: 172.30.16.1

eNodeB IP address 172.30.31.100

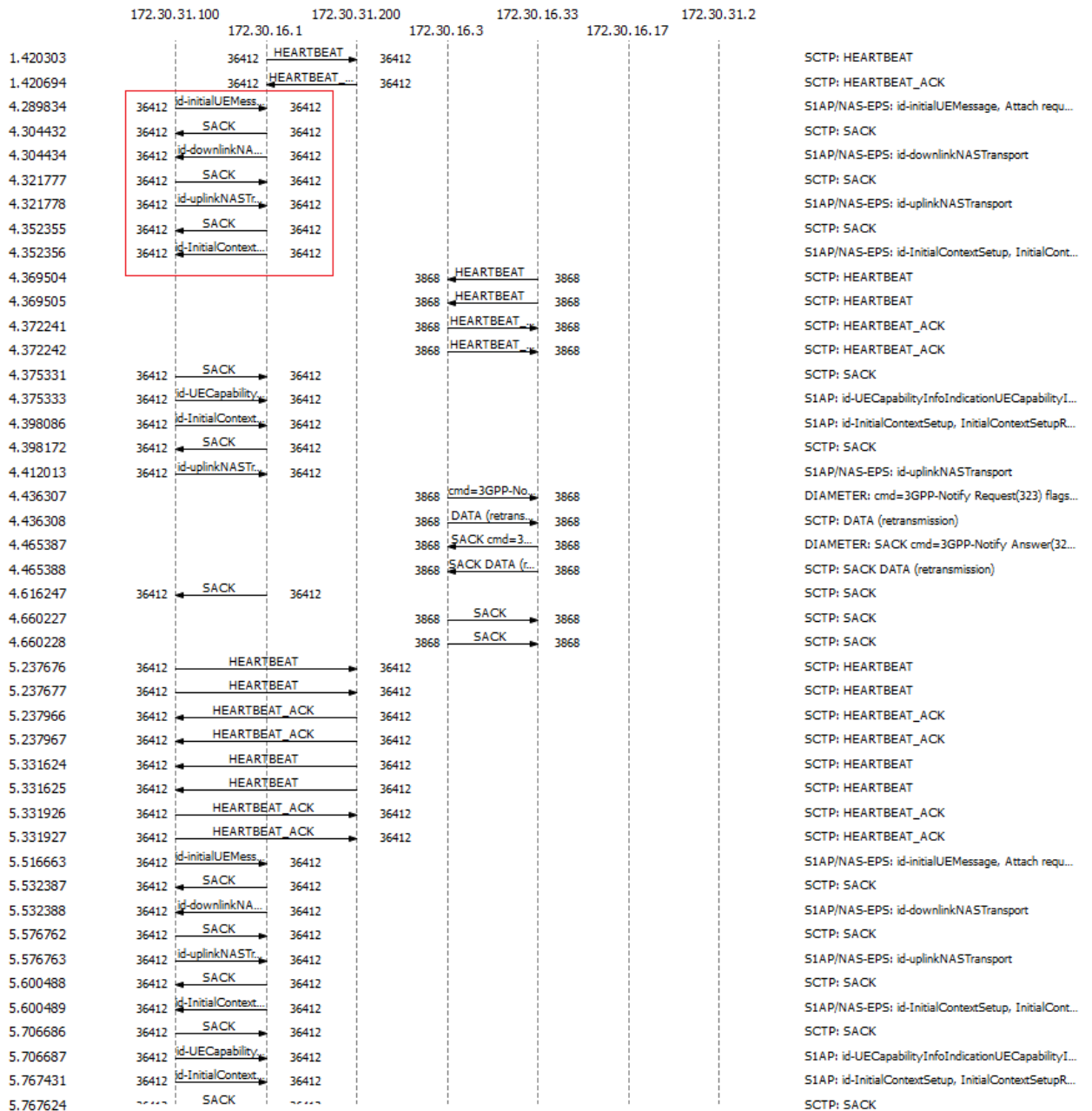

Appendix 3. VoLTE architecture

