

VYSOKÉ UČENÍ TECHNICKÉ V BRNĚ

BRNO UNIVERSITY OF TECHNOLOGY

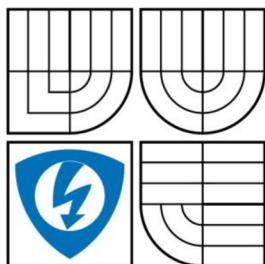

FAKULTA ELEKTROTECHNIKY A KOMUNIKAČNÍCH TECHNOLOGIÍ
ÚSTAV ELEKTROENERGETIKY

FACULTY OF ELECTRICAL ENGINEERING AND COMMUNICATION
DEPARTMENT OF ELECTRICAL POWER ENGINEERING

THE ANALYSIS OF THE POSSIBILITIES OF USING HEAT ENERGY FOR WATER HEATING, SPACE HEATING AND AIR CONDITIONING IN THE DOMESTIC SECTOR

ANALÝZA MOŽNOSTÍ VYUŽITÍ TEPLA PRO OHŘEV TEPLÉ UŽITKOVÉ VODY, VYTÁPĚNÍ A
CHLAZENÍ DOMÁCNOSTÍ

DOKTORSKÁ PRÁCE

DOCTORAL THESIS

AUTOR PRÁCE

AUTHOR

Ing. ALMABROK ABDOALHADE ALMABROK

VEDOUCÍ PRÁCE

SUPERVISOR

doc. Ing. PETR TOMAN, Ph.D.

BRNO 2014

Bibliographic citation:

ALMABROK, A. *The Analysis of the Possibilities of Using Heat Energy for Water Heating, Space Heating and Air Conditioning in the Domestic Sector*. Brno: University of Technology, Faculty of Electrical Engineering and Communication, 2014. 147 p. Supervisor dissertation work Assoc. Prof. Ing. Petr Toman, Ph.D.

I hereby declare that I composed the thesis entirely myself, that it describes my own research and the used ground work (literature, project, SW etc) is cited in enclosed list.

.....

Acknowledgements

I would like to extend special thanks to my supervisor, Assoc. Prof. Petr Toman. for his effort in providing all his assistance and guidance and for his patience. He kindly gave me enough time for consultations and discussions during whole my study period at the faculty. I would also like to thank all the officials and colleagues at department and faculty and university for all who has gave me assistance and nice accompanying throughout study years, as well.

I'd also like to give my deepest thanks to my father for his support and encouragement, and his insistence that I complete my study and get my degree in spite of the circumstances that I was passing through. Further, thanks to my family, to my great mother and special thanks for my wife to provide for and take care of our children, and her patience for the hardship even though I'm faraway.

In Brno, July 2014.

Almabrok Abdoalhade
Almabrok

.....

ABSTRACT

The growing worldwide demand for less polluting forms of energy has led to renewed interest in the use of cogeneration technologies in the residential sector due to their potential for significantly reducing the quantities of pollutants emitted in supplying residential electricity and heating. Cogeneration systems in the residential sector have the ability to produce both useful thermal energy and electricity from a single source of fuel such as oil or natural gas.

This thesis is focused on an analysis of the possibilities of using cogeneration and tri-generation for improving energy efficiency in countries where these systems are not commonly used. The first part of the thesis is oriented to the general definition of power engineering, the present energy balance in Libya from a consumption and production point of view. Chapter Five deals with the analysis of energy demand in Libya and forecast in future. The definition, development, benefits and characteristic, especially technical performance, of cogeneration and tri-generation systems are clarified in Chapters Eight and Nine. In chapter eleven the electrical consumption of typical family houses in three major cities in Libya were clarified. The last part of the thesis presents a sensitivity analysis that was focused on the calculation of the amount of energy required to cover necessities of typical house (heating, water heating and air conditioning) and the comparison between the usage of electrical energy and thermal energy to meet those requirements from technical and economic point of view.

The results of the thesis will be used for creating supporting material for energy authorities in Libya.

KEY WORDS: Absorption chiller, Air conditioning, Cogeneration, Heat recovery, Space heating, Tri-generation system, Water heating.

CONTENTS

1 INTRODUCTION	19
2 POWER ENGINEERING	20
2.1 POWER	21
2.2 GENERATION	21
2.3 TRANSMISSION	22
2.4 DISTRIBUTION	23
2.5 CONSUMPTION	23
3 SOURCES OF ENERGY	25
3.1 NON-RENEWABLE ENERGY SOURCES	25
3.1.1 NATURAL GAS.....	25
3.1.2 PETROLEUM.....	25
3.1.3 COAL.....	25
3.1.4 NUCLEAR ENERGY.....	25
3.2 RENEWABLE ENERGY SOURCES	26
3.2.1 GEOTHERMAL ENERGY.....	26
3.2.2 SOLAR ENERGY.....	26
3.2.3 BIOMASS ENERGY.....	26
3.2.4 HYDRO POWER.....	27
3.2.5 WIND POWER.....	27
4 ENERGY BALANCE IN LIBYA	28
4.1 GENERAL INFORMATION ABOUT LIBYA AND ENERGY SYSTEM	28
4.2 ENERGY SITUATION IN LIBYA	28
4.2.1 CRUDE OIL.....	28
4.2.2 NATURAL GAS.....	28
4.2.3 ELECTRICITY.....	28
4.2.4 RENEWABLE ENERGY.....	29
4.3 ENVIRONMENT	32
4.4 PRODUCTION OF ELECTRICITY	33
4.4.1 STRUCTURE OF CONSUMPTION.....	34
4.4.2 NUMBERS OF CONSUMER OF ELECTRICAL ENERGY BY TYPE OF CONSUMPTION.....	36
4.4.3 EVOLUTION AND AVERAGE OF POWER CONSUMPTION PER CAPITA.....	38
4.4.4 DAILY LOAD CURVE CHARACTERISTICS OF THE LIBYAN NETWORK.....	40
5 THE ANALYSIS OF ENERGY DEMAND	43
5.1 SCENARIO APPROACH	43
5.2 DESCRIPTION OF INPUT DATA	44

5.2.1 INPUT DATA	44
5.2.2 PEAK LOAD	44
5.2.3 REAL GDP	44
5.2.4 GDP OF SECTORS	45
5.2.5 POPULATION	46
5.2.6 HOUSEHOLDS	47
5.2.7 TEMPERATURE	48
5.2.8 INFLATION.....	48
5.3 SCENARIO ANALYSIS	48
5.3.1 LOW DEMAND	48
5.3.2 HIGH DEMAND	49
5.3.3 DELAYED MEGA PROJECT	49
5.3.4 RESULT OF SCENARIO ANALYSIS	49
6 THE OBJECTIVES OF THE THESIS.....	51
7 CONVENTIONAL THERMAL POWER PLANTS	52
8 COGENERATION (CHP).....	54
8.1 COGENERATION SYSTEM.....	55
8.1.1 THE COMPONENTS FOR A COGENERATION SYSTEM	55
8.1.2 THERMAL ENERGY STORAGE	56
8.2 HEAT TO POWER RATIO	56
8.3 SIMPLE COMPARISON BETWEEN COGENERATION AND SEPARATE PRODUCTION OF ELECTRICITY AND HEAT	58
8.3.1 GENERAL BENEFITS FOR COGENERATION SYSTEM AND MAIN POTENTIAL ADVANTAGES	59
9 TRI-GENERATION (CHCP)	60
9.1 ABSORPTION TECHNOLOGY	66
9.2 EXAMPLE FOR COMPRESSION CHILLIER AND ABSORPTION CHILLIER.....	71
9.3 COMPARISON OF UTILIZATION OF TRADITIONAL ENERGY SUPPLY MODE AND TYPICAL CHCP SYSTEM	72
10 DISTRIBUTION NETWORK	75
10.1 HEATING DISTRIBUTION NETWORK.....	75
10.1.1 PIPELINES.....	76
10.1.2 THE SUBSTATION (HEAT EXCHANGER)	77
10.2 ELECTRICAL DISTRIBUTION NETWORK.....	80
11 ELECTRICAL CONSUMPTION OF TYPICAL FAMILY HOUSES	83
11.1 CONSUMPTION IN THE DOMESTIC SECTOR.....	83
11.1.1 CONSUMERS IN TRIPOLI.....	87
11.1.2 CONSUMERS IN BENGHAZI.....	88

11.1.3 CONSUMERS IN SABHA	89
11.2 PRODUCTION COSTS AND PRICE REFORM	91
11.3 AVERAGE CONSUMPTION	93
11.4 HEATING AND COOLING SYSTEM COMPONENTS	94
11.4.1 SOURCE OF HEAT	95
11.4.2 HEAT EXCHANGER.....	95
11.4.3 DISTRIBUTION COMPONENTS	96
11.4.4 DELIVERY COMPONENTS	99
11.5 ENERGY NEEDED FOR AVERAGE CONSUMPTION OF TYPICAL HOUSES.....	100
11.5.1 USING OF HEAT FOR COVERING THE NECESSITIES OF THE TYPICAL HOUSE.....	100
11.6 HEAT LOSS AND INSTALLED POWER OF TYPICAL HOUSES.....	102
11.6.1 SMALL HOUSE.....	103
11.6.2 MEDIUM HOUSE.....	107
11.6.3 LARGE HOUSE.....	111
12 SENSITIVITY ANALYSIS.....	121
12.1 CALCULATION OF ENERGY REQUIREMENT FOR CHOSEN CITIES.....	123
13 CONCLUSION.....	130
REFERENCES	132
APPENDIX 1	136
APPENDIX 2A: HORIZONTAL VIEW OF GROUND FLOOR [46]	142
APPENDIX 2B: HORIZONTAL VIEW OF FIRST FLOOR [46].....	143
APPENDIX 2C: HORIZONTAL VIEW OF SECOND FLOOR [46].....	144
APPENDIX 2D: CROSS SECTION OF HOUSE A-A [46].....	145
APPENDIX 3: 220 KV NETWORK OF LIBYA.....	146
CURRICULUM VITAE	147

LIST OF FIGURES

<i>Fig. 2.1 Simple diagram for interconnection of network components</i>	21
<i>Fig. 2.2 Energy flows in the global electricity system [TWh][4]</i>	22
<i>Fig. 2.3 Rates of world energy usage [6]</i>	24
<i>Fig. 4.1 Average monthly, daily solar radiation on horizontal surface [11]</i>	29
<i>Fig. 4.2 Average global solar radiation on the horizontal plane [11]</i>	30
<i>Fig. 4.3 Location of photovoltaic systems [11]</i>	30
<i>Fig. 4.4 Photovoltaic system for water pumping [11]</i>	31
<i>Fig. 4.5 Wade Marsite PV Central Plant [11]</i>	31
<i>Fig. 4.6 Wind potential for Libyan coast area – average wind speed in m/s [11]</i>	32
<i>Fig. 4.7 CO₂ Emissions by sectors</i>	33
<i>Fig. 4.8 Electrical energy production (1970-2008)</i>	33
<i>Fig. 4.9 Percentage of electrical energy produced in [MWh], by type of generation (2008)</i> .	34
<i>Fig. 4.10 Increasing of maximum load (1970-2008)</i>	35
<i>Fig. 4.11 Maximum and minimum load (2001-2008)</i>	36
<i>Fig. 4.12 Typical Load classification</i>	36
<i>Fig. 4.13 Number of electric consumers in Libya 2008</i>	37
<i>Fig. 4.14 Electric energy consumed in year 2008</i>	38
<i>Fig. 4.15 Average of energy consumption per capita in Libya</i>	39
<i>Fig. 4.16 Existing and planned interconnection [72]</i>	40
<i>Fig. 4.17 Typical normalized daily Load curves for years 2000 & 2008. The normalization factor is the peak load within the respective year [15]</i>	41
<i>Fig. 4.18 Maximum and minimum load in 2008</i>	41
<i>Fig. 4.19 Daily load curve of the maximum and minimum load in 2008</i>	42
<i>Fig. 5.1 Peak load (MW) and real GDP (Million Libyan Dinar) [16]</i>	45
<i>Fig. 5.2 Population (Thousand) and Peak load [MW] [16]</i>	46
<i>Fig. 5.3 Scenario analysis [MW] [16]</i>	49
<i>Fig. 5.4 Scenario analysis (Mega Project is delayed) [MW] [16]</i>	50
<i>Fig. 7.1 Coal Fired Thermal Power Plant [60]</i>	52
<i>Fig. 7.2 Simple scheme for conventional power plants</i>	53
<i>Fig. 8.1 Schematic diagram of Cogeneration (CHP) [20]</i>	54
<i>Fig. 8.2 Cogeneration with prime mover gas turbine or engine [21]</i>	55

<i>Fig. 8.3 Separate production of electricity and heat [23]</i>	58
<i>Fig. 8.4 Cogeneration (CHP) production of electricity and heat [23]</i>	59
<i>Fig. 9.1 Schematic diagram of Tri-generation process [24]</i>	60
<i>Fig. 9.2 Schematic showing overall tri-generation system configuration [24]</i>	61
<i>Fig. 9.3 Typical CHCP system [27]</i>	61
<i>Fig. 9.4 The principal of an absorption cooling machine</i>	67
<i>Fig. 9.5 Two stage-fired absorption machine</i>	68
<i>Fig. 9.6 Schematic diagram of power generation and cooling with electricity [39]</i>	71
<i>Fig. 9.7 Schematic diagram of power generation and absorption cooling [39]</i>	72
<i>Fig. 9.8 Energy flow of traditional supply mode [27]</i>	73
<i>Fig. 9.9 Energy flow of typical CHCP system [27]</i>	73
<i>Fig. 10.1 District heating network [31]</i>	75
<i>Fig. 10.2 Typical piping installations [32]</i>	76
<i>Fig. 10.3 Distribution Network</i>	77
<i>Fig. 10.4 Different types of thermal energy storage [34]</i>	78
<i>Fig. 10.5 Large Hot water storage (construction and final state) [33]</i>	79
<i>Fig. 10.6 Electric distribution networks [5]</i>	80
<i>Fig. 11.1 Annually energy consumed depending of purpose of use of average consumer</i>	86
<i>Fig. 11.2 Annual electrical energy consumption, depending of purpose of use, Tripoli</i>	88
<i>Fig. 11.3 Annual electrical energy consumption, depending of purpose of use, Benghazi</i>	89
<i>Fig. 11.4 Annual electrical energy consumption, depending of purpose of use, Sabha</i>	90
<i>Fig. 11.5 Average Consumption for average consumers</i>	94
<i>Fig. 11.6 Heating /cooling system for typical house</i>	95
<i>Fig. 11.7 Types of heat exchanger [42]</i>	96
<i>Fig. 11.8 Closed and Open loop systems [43]</i>	97
<i>Fig. 11.9 Type of pipe distribution [43]</i>	97
<i>Fig. 11.10 Hot water system</i>	98
<i>Fig. 11.11 Chiller system</i>	98
<i>Fig. 11.12 Basic Classes of residential type baseboard emitters</i>	99
<i>Fig. 11.13 Scheme for small house (Horizontal view)</i>	103
<i>Fig. 11.14 Cross section A-A of building</i>	104
<i>Fig. 11.15 Three-dimensional model of small house</i>	104
<i>Fig. 11.16 Power flow in the system of small house network</i>	106

<i>Fig. 11.17 Heating system of small house.....</i>	<i>106</i>
<i>Fig. 11.18 Scheme for medium house</i>	<i>107</i>
<i>Fig. 11.19 Cross section A-A of the building</i>	<i>108</i>
<i>Fig. 11.20 Three-dimensional model of medium house</i>	<i>108</i>
<i>Fig. 11.21 Power flow in the system of medium house</i>	<i>110</i>
<i>Fig. 11.22 Heating system of medium house.....</i>	<i>110</i>
<i>Fig. 11.23 Scheme for large house ground floor</i>	<i>112</i>
<i>Fig. 11.24 Scheme of Large House first floor.....</i>	<i>113</i>
<i>Fig. 11.25 Cross section A-A of the building</i>	<i>113</i>
<i>Fig. 11.26 Three-dimensional model of large house</i>	<i>114</i>
<i>Fig. 11.27 Power flow in the system of large house network.....</i>	<i>116</i>
<i>Fig. 11.28 Heating system of large house</i>	<i>116</i>
<i>Fig. 11.29 Total consumption of energy</i>	<i>118</i>
<i>Fig. 12.1 Family House [46].....</i>	<i>121</i>
<i>Fig. 12.2 Energy requirement for heating and cooling.....</i>	<i>125</i>
<i>Fig. 12.3 Energy input (requirement) when use electrical & heat (single, double)</i>	<i>128</i>
<i>Fig. 12.4 Price in CZK of input energy (electrical & heat with single and double effect)</i>	<i>129</i>

LIST OF TABLES

<i>Tab. 4.1 Construction plan for renewable energy plants.....</i>	32
<i>Tab. 4.2 Electrical energy production [GWh].....</i>	33
<i>Tab. 4.3 Maximum load in [MW].....</i>	34
<i>Tab. 4.4 Maximum and minimum load in [MW].....</i>	35
<i>Tab. 4.5 Number and type of consumers in Libya at year 2008</i>	37
<i>Tab. 4.6 Electrical energy consumed in Libya at year 2008.....</i>	37
<i>Tab. 4.7 Annual consumption per capita</i>	38
<i>Tab. 4.8 Libyan-Egyptian interconnection network.....</i>	39
<i>Tab. 4.9 Libyan-Tunisian interconnection network</i>	39
<i>Tab. 5.1 Mega Project Plan</i>	44
<i>Tab. 5.2 Real GDP (%) [16]</i>	45
<i>Tab. 5.3 Categories of sectors [16].....</i>	45
<i>Tab. 5.4 Regression analysis results [16]</i>	46
<i>Tab. 5.5 Libyan population (units: 1,000) [16]</i>	47
<i>Tab. 5.6 Forecasted population (units:1,000) [16]</i>	47
<i>Tab. 5.7 Historical households (units: 1) [16].....</i>	47
<i>Tab. 5.8 Forecasted households (units: 1,000) [16].....</i>	48
<i>Tab. 8.1 Cogeneration prime mover</i>	58
<i>Tab. 9.1 Characteristics and parameters of prime movers in CHCP systems.....</i>	65
<i>Tab. 9.2 Comparison between compression and absorption chillers</i>	72
<i>Tab. 10.1 Typical parameters of thermal energy storage systems [33].....</i>	80
<i>Tab. 11.1 Number of questionnaires distributed by regions</i>	83
<i>Tab. 11.2 Distribution of electrical devices on consumers</i>	84
<i>Tab. 11.3 Total annually consumed energy depending of purpose of the usage</i>	85
<i>Tab. 11.4 Maximum and minimum and average annual consumption [kWh]</i>	86
<i>Tab. 11.5 Maximum and minimum and average temperature in Libya</i>	87
<i>Tab. 11.6 Proportion of annual electrical energy consumption</i>	87
<i>Tab. 11.7 Proportion of annual electrical energy consumption</i>	88
<i>Tab. 11.8 Proportion of annual electrical energy consumption</i>	90
<i>Tab. 11.9 Production cost of electric energy unit.....</i>	91
<i>Tab. 11.10 Historic fuel prices to the electricity sector 2001-2009 [Dinar/m³] [13].....</i>	91
<i>Tab. 11.11 Unit price for various sectors [Dirham/kWh].....</i>	92

<i>Tab. 11.12 Average consumption for average consumers [kWh]</i>	<i>93</i>
<i>Tab. 11.13 Installed power [W]</i>	<i>94</i>
<i>Tab. 11.14 Used energy for average consumption.....</i>	<i>100</i>
<i>Tab. 11.15 Energy needed when use heat energy instead electric.....</i>	<i>101</i>
<i>Tab. 11.16 Cost of energy (Heat and Electric)</i>	<i>101</i>
<i>Tab. 11.17 Total cost of electric energy and heat energy with single and double stage</i>	<i>102</i>
<i>Tab. 11.18 Small house measurements and indoor and outdoor temperature</i>	<i>105</i>
<i>Tab. 11.19 Heat loss of small house.....</i>	<i>105</i>
<i>Tab. 11.20 Installed power for space heating of small house.....</i>	<i>107</i>
<i>Tab. 11.21 Medium house measurements and indoor and outdoor temperature</i>	<i>109</i>
<i>Tab. 11.22 Heat loss of medium house.....</i>	<i>109</i>
<i>Tab. 11.23 Installed power for space heating of medium house.....</i>	<i>111</i>
<i>Tab. 11.24 Large house measurements and indoor and outdoor temperature</i>	<i>114</i>
<i>Tab. 11.25 Heat loss of large house.....</i>	<i>115</i>
<i>Tab. 11.26 Installed power for space heat of large house</i>	<i>117</i>
<i>Tab. 11.27 Supposed of installed power and calculation of total consumption.....</i>	<i>118</i>
<i>Tab. 11.28 Energy needed when heat energy instead of electric energy is used.....</i>	<i>119</i>
<i>Tab. 11.29 A comparison between the amounts of energy required and difference between the prices</i>	<i>119</i>
<i>Tab. 11.30 The amount of thermal energy required, and the difference in prices.....</i>	<i>120</i>
<i>Tab. 12.1 The resulting values of heating demand [46]</i>	<i>121</i>
<i>Tab. 12.2 Formulae for calculation heating degree days (HDD) [48].....</i>	<i>123</i>
<i>Tab. 12.3 Formulae for calculation cooling degree days (CDD) [48].....</i>	<i>123</i>
<i>Tab. 12.4 Heating degree days (HDD) and Cooling degree days (CDD).....</i>	<i>124</i>
<i>Tab. 12.5 Energy needed for heating and cooling</i>	<i>124</i>
<i>Tab. 12.6 When using electric energy to cover the necessities</i>	<i>125</i>
<i>Tab. 12.7 When using heat energy to cover the necessities</i>	<i>126</i>
<i>Tab. 12.8 Total input energy in kWh and GJ and Price of energy in CZK.....</i>	<i>128</i>

LIST OF SYMBOLS

<i>Ave Consm</i>	Average Consumption	[kWh]
<i>Btu</i>	British thermal units	[-]
<i>Btu / ft³</i>	British thermal unit/ Cubic feet	[-]
<i>Btu / Wh</i>	British thermal unit /Watt hour	[-]
<i>Btu / h</i>	British thermal unit / hour	[-]
<i>B_{Consm}</i>	Benghazi consumption	[kWh]
<i>B_{Costm No}</i>	Benghazi consumers number	[-]
<i>CO₂ emissions</i>	Carbon dioxide emissions	[kg/y]
<i>Consm_{sm wh}</i>	Consumption of small sector for water heating	[kWh]
<i>Consm_{med sh}</i>	Consumption of medium sector for space heating	[kWh]
<i>Consm_{lar ac}</i>	Consumption of large sector for air condition	[kWh]
<i>Dirham / kWh</i>	Dirham/kilowatt hour	[-]
<i>d</i>	Number of days in the heating season	[-]
<i>E_{in}</i>	Input energy to feeder	[kWh]
<i>E_b</i>	Billed energy to Consumer	[kWh]
<i>GWh</i>	Giga watt hour	[-]
<i>h.d.m</i>	Hour. Day. Month	[-]
<i>H_{ght}</i>	Height	[m]
<i>L_{nth}</i>	Length	[m]
<i>Loss_{T+D}</i>	Energy losses by transmission and distribution	[%]
<i>J</i>	Joule	[J]
<i>kWh / kg</i>	Kilowatt hour/kilogram	[-]
<i>kV</i>	Kilovolt	[kV]
<i>kW</i>	Kilowatt	[kW]
<i>kW / ton</i>	Kilowatt ton	[-]
<i>kWh / c</i>	Kilowatt hour/ Capita	[-]
<i>kWp</i>	Kilowatt peak	[kW]
<i>kWe</i>	Kilowatt electric	[-]
<i>kW / RT</i>	Kilowatt/ Refrigeration ton	[-]
<i>CZK / kWh</i>	Czech Koruna/kilowatt hour	[CZK]
<i>CZK / GJ</i>	Czech Koruna/ Giga Joule	[CZK]

m	Meter	[m]
m^3	Cubic meter	[m]
m^2	Square meter	[m]
m/s	Meter per second	[m/s]
m^3 / MWh	Cubic meter/Mega watt hour	[-]
MWh	Mega watt hour	[-]
MPs	Mega Pascal	[-]
MJ / m^3	Mega Joule/ Cubic meter	[-]
MJ / kg	Mega Joule/kilogram	[-]
MW	Megawatt	[MW]
PSi	Pounds per square inch	[lb/sq in]
Q_e	Cross electric output	[-]
Q_{fuel}	Fuel input energy	[-]
Q_{hl}	Annual energy consumption for heating	[Wh/y]
Q_{heat}	Heating energy	[MWh/y]
Q_{Cool}	Cooling energy	[MWh/y]
Q_{SH}	Specific heat Loss for one degree	[W/°C]
S_{Consm}	Sabha consumption	[kWh]
$S_{Costm No}$	Sabha consumers number.	[-]
T	Calculation period (8760h/yr)	[h/y]
T_c	Cold Temperature	[°C]
T_H	Hot Temperature	[°C]
t_{in}	Average indoor temperature in the house	[°C]
t_{em}	Average outdoor temperature in heating season	[°C]
t_e	Design outdoor temperature	[°C]
T_{max}	Maximum temperature	[°C]
T_{min}	Minimum temperature	[°C]
T_{base}	Base temperature	[°C]
T_{Consm}	Tripoli consumption,	[kWh]
$T_{Costm No}$	Tripoli consumers number.	[-]
T_{Int}	Indoor temperature	[°C]

T_{Ext}	Outdoor temperature	[°C]
η_{tot}	Overall efficiency, (Total efficiency)	[%]
η_{CHP}	Total efficiency for combined heat and power	[%]
η_e	Electric efficiency	[%]
ε	Correction factor for temperature reduction,	[-]
ΔT	Difference of temperatures	[°C]
α	Power to heat ratio	[-]

LIST OF ABBREVIATIONS

AC	Alternating Current
ACs	Split Air-condition Unit
CSES	Center of Solar Energy Studies
CIS	Commonwealth of Independent States
CCGT	Combined-cycle Gas Turbine
C, Cycle	Combined Cycle
CHP	(Cogeneration) Combined Heat and Power
CHCP	(Tri-generation) Combined Heat, Cooling and Power
CDD	Cooling degree days
CO ₂	Carbon dioxide
COP	Coefficient of Performance
CZK	Czech Koruna
DHW	Domestic Hot Water
DOE	Department of Energy
EER	Energy Efficiency Ratio
EU	European Union
GECOL	General Electric Company of Libya
GDP	Gross Domestic Product
HRSR	Heat Recovery Steam Generator
HHV	High Heat Value
H.F.O	Heavy Fuel Oil
HES	Heat Exchanger Station
HVDC	High-voltage direct current
HD	District heating
HSPF	Heating seasonal performance factor
HDD	Heating degree days
IEA	International Energy Agency
LF	Load Factor
LHV	Low Heat Value
LDY	Libyan Dinar

L.F.O	Light Fuel Oil
Max	Maximum
Min	Minimum
NG	Natural Gas
NO _x	Nitrogen oxide
OECD	Organization for Economic Cooperation and Development
OHL	Overhead Line
PV	Photovoltaic
PCMs	Phase Change Materials
RAD	Radiator
RT	Refrigeration ton
SEER	Seasonal Energy efficiency Ratio
Toe	Ton of Oil equivalent
T&D	Transmission and Distribution
TES	Thermal Energy Storage
TCS	Thermo Chemical Storage
UC	Underground Cable
UTES	Underground Thermal Energy Storage
WAC	Window Air-condition Unit

1 INTRODUCTION

The world's energy demand is growing day by day in different parts of the world, with an increase in population numbers, and rapid development of human lifestyles, and associated with which is a change in people's daily lives and a wider use of electrical and electronics appliances for various daily needs such as lighting, cooking, heating, air-conditioning, refrigeration, transportation, and telecommunications.

The challenges for engineers and researchers are how to provide sustainable energy sources, and how to transfer energy to the consumer more economically, as well as maintain the stability of flow of energy in accordance with established criteria. In addition, they need to build large central power stations and construct transmission lines for long distances with the consequent need for substantial provision of capital for such projects. Further factors are some of the problems associated with generating electricity from traditional sources like oil, coal, uranium and others, such as environmental pollution and global warming caused by greenhouse gases from factories and power plants as a result of burning of fossil fuels. These have several problems: high fuel prices from time to time reflect negatively on the cost of production and power generation: there is a limited availability of these resources (oil and coal) and lack of reserve day by day: there are significant losses of energy in transmission lines, which extend long distances from generating plants to locations of demand.

Co-generation will enable us to benefit by generating electricity from a large part of energy wasted and used to heat water for heating or domestic use. The tri-generation power plant is further based on the joint exploitation of a large part of energy lost in the process of air-conditioning and cooling of spaces and buildings, with addition of some equipment (absorption chillers) to cogeneration units. They are needed in countries that have a warm climate and extended summer periods of several months with high temperatures, and they are needed to cool work places, factories, hospitals and warehouses, besides the generation of electric power. More recently the bulk and most of the attention of researchers searching for sources of clean and environmentally friendly energy has been to reduce dependence on traditional energy sources and to avoid the problems caused by conventional energy sources, which are non-clean and cause the problems of environmental pollution and some other damages. In addition, this attention has been focused on the economic operation of power plants and transmission and distribution networks and on reducing losses in energy-producing and transference, and on attaining the highest operating efficiency.

Cogeneration (combined heat and power CHP) is the most effective way of operating power stations and transmission lines economically by generating two different types of energy at the same time using a single fuel source in same place or area where the energy is needed. The cogeneration uses a large portion of the heat that is discarded in conventional power generation and harnesses this thermal energy for use to provide heating or cooling at industrial facilities, district energy systems, and commercial buildings by recycling this wasted heat. Cogeneration systems typically achieve an overall effective efficiency higher than that of conventional fossil-fuel power plants.

2 POWER ENGINEERING

Power engineering is a subfield of engineering that deals with the generation, transmission and distribution of electric power, as well as the electrical devices connected to such systems including generators, motors and transformers. Although much of the field is concerned with the problems of three-phase AC power - the standard for large-scale power transmission and distribution across the modern world - a significant fraction of the field is concerned with the conversion between AC and DC power, as well as the development of specialized power systems such as those used in aircraft or for electric railway networks. Electricity became a subject of scientific interest in the late 17th century, and with the work of over the next two centuries a number of important discoveries were made including the incandescent light bulb and the voltaic pile [1].

Probably the greatest discovery with respect to power engineering came from Michael Faraday, who in 1831 discovered that a change in magnetic flux induces an electromotive force in a loop of wire, a principle known as electromagnetic induction, which helps explain how generators and transformers work [1].

However supply was intermittent and in 1882 Thomas Edison and his company, The Edison Electric Light Company, developed the first steam-powered electric power station on Pearl Street in New York City. The power station used direct current. Since the direct current power could not be easily transformed to the higher voltages necessary to minimize power loss during transmission, the possible distance between the generators and load was limited to around half-a-mile (800 m). That same year in London, Lucien Gaulard and John Dixon Gibbs demonstrated the first transformer suitable for use in a real power system. The practical value of Gaulard and Gibbs' transformer was demonstrated in 1884 at Turin where the transformer was used to light up forty kilometers (25 miles) of railway from a single alternating current generator [1].

One of Westinghouse's engineers, William Stanley, recognized the problem with connecting transformers in series as opposed to parallel and also realized that making the iron core of a transformer a fully enclosed loop would improve the voltage regulation of the secondary winding. Using this knowledge, he built a much improved alternating current power system [1].

AC power has the advantage of being easy to transform between voltages and is able to be generated and utilized by brushless machinery. DC power remains the only practical choice in digital systems and can be more economical to transmit over long distances at very high voltages. The ability to easily transform the voltage of AC power is important for two reasons. Firstly, power can be transmitted over long distances with less loss at higher voltages. So in power networks where generation is distant from the load, it is desirable to step-up the voltage of power at the generation point and then step-down the voltage near the load. Secondly, it is often more economical to install turbines that produce higher voltages than would be used by most appliances, so the ability to easily transform voltages means this mismatch between voltages can be easily managed [2].

Solid state devices, which are products of the semiconductor revolution, make it possible to transform DC power to different voltages, build brushless DC machines and convert between AC and DC power. Nevertheless, devices utilizing solid state technology are often more expensive than their traditional counterparts, so AC power remains in widespread use [2].

2.1 Power

Power Engineering deals with the generation, transmission and distribution of electricity, as well as the design of a range of related devices. These include transformers, electric generators, electric motors and power electronics. The power grid is an electrical network that connects a variety of electric generators to the users of electric power. Users purchase electricity from the grid, thus avoiding the costly exercise of having to generate their own. Power engineers may work on the design and maintenance of the power grid as well as the power systems that connect to it. Such systems are called on-grid power systems and may supply the grid with additional power, draw power from the grid or do both. Power engineers may also work on systems that do not connect to the grid. These systems are called off-grid power systems and may be used in preference to on-grid systems for a variety of reasons. For example, in remote locations it may be cheaper for a mine to generate its own power rather than pay for connection to the grid [3].

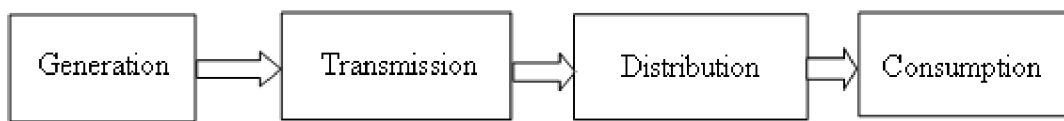

Fig. 2.1 Simple diagram for interconnection of network components

Power systems are a network of interconnected components which convert different forms of energy to electrical energy see Fig. 2.1. Modern power systems consist of three main subsystems: the generation subsystem, the transmission subsystem, and the distribution subsystem. In the generation subsystem, the power plant produces the electricity. The transmission subsystem transmits the electricity to the load centers. The distribution subsystem continues the process by transmitting the power to the customers. The utilization system is concerned with the different uses of electrical energy like illumination, refrigeration, traction, electric drives, etc [3].

2.2 Generation

Generation of electrical power is a process whereby energy is transformed into an electrical form. There are several different transformation processes, among which are chemical, photovoltaic, and electromechanical. Electromechanical energy conversion is used in converting energy from coal, petroleum and natural gas, and uranium into electrical energy. Of these, all except the wind energy conversion process make use of a synchronous AC generator coupled to a steam, gas or hydro turbine, so that the turbine converts steam, gas, or water flow into rotational energy, and the synchronous generator then converts the rotational energy of the turbine into electrical energy. It is the turbine-generator conversion process that is by far most economical and consequently most common in the industry today. The AC synchronous machine is the most common technology for generating electrical energy. It is called synchronous because the composite magnetic field produced by the three stator windings rotate at the same speed as the magnetic field produced by the field winding on the rotor. The excitation control system is used on synchronous machines to regulate terminal voltage, and the turbine-governor system is used to regulate the speed of the machine. The operating costs of generating electrical energy are determined by the fuel cost and the efficiency of the power station [3].

Improving supply efficiency in the heat and electricity sectors offers an important opportunity. For example, the average global efficiency of traditional fossil-fuelled power

generation has remained stagnant for decades at 35-37% (IEA, 2006). About two-thirds of the primary energy that is converted to produce electricity is lost as “waste” heat (IPCC, 2007) that can, in part, be used to satisfy the demand for heat in industries, buildings, towns and cities. Further, the transmission and distribution (T&D) of this electricity from large central power stations contributes further losses of around 9% of net generation, so that only about one-third is delivered to the end customer. Fig. 2.2 shows these losses for the global power system, demonstrating that 68% of total energy input is lost in energy each year before it reaches the end consumer [4].

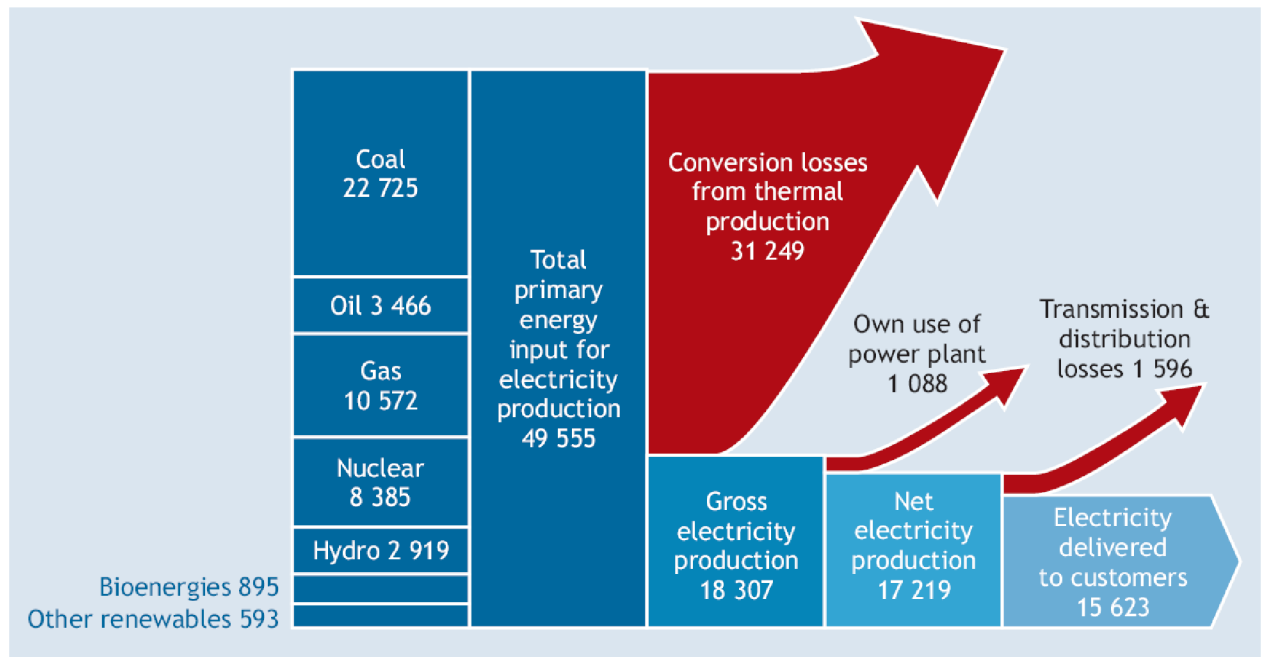

Fig. 2.2 Energy flows in the global electricity system [TWh][4]

2.3 Transmission

Electricity is transported to load locations from a power station to a transmission subsystem. Therefore we may think of the transmission system as providing the medium of transportation for electrical energy. The transmission system may be subdivided into a bulk transmission system and a sub-transmission system. The functions of the bulk transmission are to interconnect generators, to interconnect various areas of the network, and to transfer electrical energy from the generators to the major load centers. This portion of the system is called "bulk" because it delivers energy only to so-called bulk loads, such as the distribution system of a town, city, or large industrial plant. The function of the sub-transmission system is to interconnect the bulk power system with the distribution system. Transmission circuits may be built either underground or overhead. Overhead transmission is used usually because, for a given voltage level, overhead conductors are much less expensive than underground cables. The transmission system is a highly integrated system. It is referred to the substation equipment and transmission lines. The substation contains the transformers, relays and circuit breakers [3].

2.4 Distribution

The distribution system transports power from the transmission system to the customer. The equipment associated with the distribution system includes substation transformers connected to the transmission systems, distribution lines from the transformers to the customers and protection and control equipment between the transformer and the customer. The protection equipment includes lightning protectors, circuit breakers, disconnectors and fuses. The control equipment includes voltage regulators, capacitors, and relays [3].

Distribution networks are typically of two types, radial or interconnected. A radial network leaves the station and passes through the network area with no normal connection to any other supply. This is typical of long rural lines with isolated load areas. An interconnected network is generally found in more urban areas and will have multiple connections to other points of supply. These points of connection are normally open but allow various configurations to the operating utility by closing and opening switches. Operation of these switches may be by remote control from a control center. The benefit of the interconnected model is that in the event of a fault or required maintenance a small area of network can be isolated and the remainder kept on supply.

Within these networks there may be a mix of overhead line construction utilizing traditional utility poles and wires and, increasingly, underground construction with cables and indoor or cabinet substations. However, underground distribution is significantly more expensive than overhead construction [5].

2.5 Consumption

Consumption is defined as end use of energy. The global consumption of energy is increasing; it is linked with increases in population and development of lifestyle.

In 2009, world energy consumption decreased for the first time in 30 years by -1.1% or 130 Mtoe (Megaton oil equivalent), as a result of the financial and economic crisis (GDP dropped by 0.6% in 2009). This evolution is the result of two contrasting trends. Energy consumption growth remained vigorous in several developing countries, specifically in Asia ($+4\%$). Conversely, in OECD, consumption was severely cut by 4.7% in 2009 and was thus almost down to its 2000 levels. In North America, Europe and the CIS, consumptions shrank by 4.5% , 5% and 8.5% respectively due to the slowdown in economic activity. China became the world's largest energy consumer (18% of the total) since its consumption surged by 8% during 2009 (up from 4% in 2008) [6].

Total world energy supply (or consumption) is different from actual world energy usage due to energy loss. For example, in 2008, total world energy supply was 143,851 TWh, while end use was 98,022 TWh. Energy loss depends on the energy source itself, as well as the technology used. For example, Nuclear Power (as of 2008) loses 67% of its energy to water cooling systems.

In 2008, world nuclear energy was 8,283 TWh (constituting 5.8% of total world energy), while nuclear energy end-use was 2,731 TWh.

According to IEA total world energy supply (consumption) was 102,569 TWh (1990); 117,687 TWh (2000); 133,602 TWh (2005) and 143,851 TWh (2008). World power generation (electricity) was 11,821 TWh (1990); 15,395 TWh (2000); 18,258 TWh (2005) and 20,181 TWh (2008). Compared to power supply 20,181 TWh the power end use was only 16,819 TWh in 2008 including EU27: 2 857 TWh, China 2 883 TWh and USA 4 533 TWh [6].

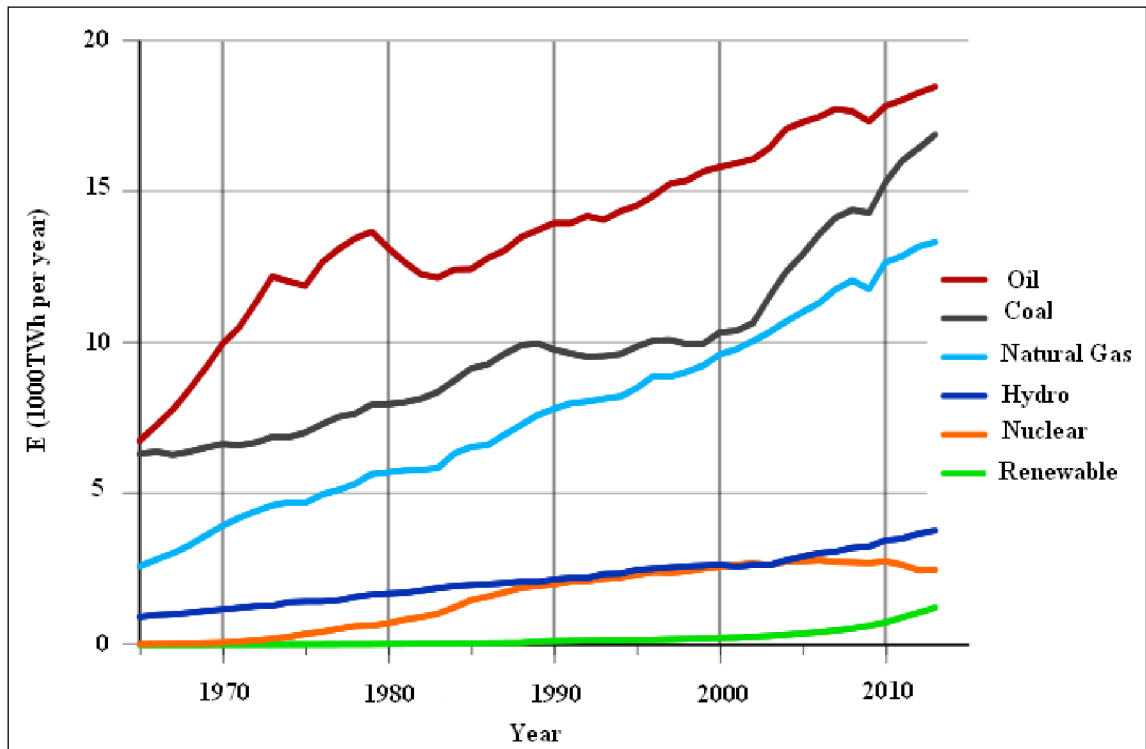

Fig. 2.3 Rates of world energy usage [6]

3 SOURCES OF ENERGY

Sources of energy classified into two groups:

3.1 Non-renewable Energy sources

Sources are considered to be non-renewable sources if they cannot be replenished (made again) in a short period of time. Primary examples of non-renewable energy resources are the fossil fuels - oil, natural gas, and coal. Sources come out of the ground as liquids, gases, and solids. Most of our energy comes from non-renewable energy sources.

3.1.1 Natural Gas

Natural Gas is a fossil fuel; as is known, it is made up mostly of methane, and a combination of hydrogen and carbon. Natural gas burns more cleanly than other hydrocarbon fuels, such as oil and coal, and produces less carbon dioxide per unit of released energy. For an equivalent amount of heat, burning natural gas produces about 30 percent less carbon dioxide than burning petroleum and about 45 percent less than burning coal [7].

Natural gas is sold in volume units. The heat amount is provided in an unit of volume of burned natural gas and is often measured in British thermal units (Btu) per cubic feet. The amount of energy of natural gas can be converted from Btu per cubic feet to Joules per cubic meter. If 1 Btu equals 1055.1 J and 1 ft³ equals 0.028316 m³, then 1000 Btu/ft³ multiplied by 1055.1 J and divided by 0.028316 m³ is equal to 37 MJ/m³, which is the average energy content of natural gas [8]. The measurement of net heating value of natural gas is used by utility companies and it is often 1000 to 1100 Btu/ft³, 37 to 40 MJ/ m³.

3.1.2 Petroleum

Petroleum (oil) is a member of the fossil fuels. It is the main source of power in the world and contributes to the production of the bulk of the energy currently produced. One barrel of oil is equivalent to 5861.52 MJ.

3.1.3 Coal

Coal is the largest source of energy for the generation of electricity worldwide, as well as one of the largest worldwide anthropogenic sources of carbon dioxide releases [9].

Coal is a rock that burns as it releases energy. It is mostly made of the chemical element carbon. Brown coal is crumbly, and black coal is hard and glossy. The greater percentage of the coal that is carbon, the higher its rank or potential energy [10]. Coal has an energy value of 24 MJ/kg, which is the same as 6.67 kWh/kg. However, a coal fired power plant will only have an efficiency of about 30 percent, so coal power plants obtain approximately 2.0 kWh per kilogram of burned coal.

3.1.4 Nuclear energy

The principle of electricity generation in nuclear power plants is similar to that of conventional thermal power plants. By heat, the water is boiled to high pressure steam. The steam rotates the turbine. The generator attached to the turbine generates electricity. In a nuclear power

plant, the heat needed for producing electricity is generated in a nuclear reactor by the fission of the atomic nucleus. The difference consists in the source of heat only. In thermal plants, heat is produced from fossil fuels (coal, gas) whereas in nuclear power plants, nuclear fuel is used (natural or enriched uranium). In the energy production, nuclear energy replaces fossil fuels, mainly coal, which poses significant environmental hazards. Of the new energy forms, nuclear power is so far the only one ready for large-scale energy production. In addition, nuclear power is economical [10].

3.2 Renewable energy sources

Sources are considered to be renewable if they can be rapidly replenished in short period time by natural processes. Primary examples of renewable energy resources are solar energy, wind energy, hydropower, and biomass.

3.2.1 Geothermal Energy

Geothermal energy can be harnessed from the Earth's natural heat associated with active volcanoes or geologically young inactive volcanoes still giving off heat at depth. Steam from high-temperature geothermal fluids can be used to drive turbines and generate electrical power, while lower temperature fluids provide hot water for space-heating purpose, heat for greenhouses and industrial uses, and hot or warm springs at resort spas. For example, geothermal heat warms more than 70 percent of the homes in Iceland [10].

3.2.2 Solar Energy

Solar energy is provided by the Sun and it is the most inexhaustible and the cleanest source of energy. The light radiation does not provide uniform amounts each day and is not in concentrated form. Consequently, the barriers to greater use of solar energy are mainly diffusion and the inability to store solar energy economically, use it directly, or convert it into electricity [10]. There are two principles of solar radiation to electricity conversion, these are:

- solar photovoltaic systems.
- solar concentration of thermal power.

3.2.3 Biomass Energy

Biomass describes all solid material of animal or vegetable origin from which energy may be extracted. Plant products (such as corn husks, branches, or peanut shells), waste paper, and cow dung are examples of biomass fuels. Biomass can be heated, burned, fermented, or treated chemically to release energy.

Since all biomass is produced by photosynthesis, basic research in photosynthesis may provide systems that directly convert sunlight into fuels. Although biomass already has many uses, from direct burning of wood and wood residues to converting animal wastes to gas, it will play a greater role in the future [10].

The fuel at biomass power plants is biomass or biofuel. Electricity generation is similar to that at thermal power plants in firing fossil fuels (coal, gas), but with substantially lower CO₂ emission levels. According to the type of biofuel used and bioenergy to electricity conversion

equipment, there are a number of basic concepts of electricity and heat generation. These are in particular:

- steam boiler (stoker-fired, fluidized bed) for solid or gaseous biofuel with a steam turbine and an electric generator
- internal combustion turbine with an electric generator for biogas from animal excrement or for wood gas - gasified wood
- biogas or wood gas driven piston gas motor with a generator
- bio-oil or ethanol driven piston motor with a generator

Electrochemical fuel cell powered by biogas or liquid biofuel to achieve the utmost utilization of the fuel energy; the above sources are largely implemented as cogeneration units.

Biomass constitutes the world's highest renewable energy potential. It is comprised of materials of plant and animal origin, fit for energy utilization. Biomass is considered in terms of CO₂ emissions to be a neutral fuel, since only as much CO₂ is released in burning it as is received by the plant while growing.

3.2.4 Hydro Power

The principle of the operation of hydroelectric power plants is conversion of mechanical into electric energy; the production depends on the annual hydrologic situation given by seasonal rain or runoff snow pack [10].

Hydropower is currently the most common form of renewable energy and plays an important part in global power generation. Worldwide hydropower produced 3 288 TWh, equivalent to 16.3% of global electricity production, (20 181 TWh) in 2008. Hydropower production in OECD countries reached 1 381 TWh, accounting for 12.9% of gross electricity production; hydropower in non-OECD countries produced 1 906 TWh, equal to 20.1% of gross electricity production, and the overall technical potential for hydropower is estimated to be more than 16 400 TWh/yr.

Hydropower's storage capacity and fast response characteristics are especially valuable to meet sudden fluctuations in electricity demand and to match supply from less flexible electricity sources and variable renewable sources.

The costs of power production from hydropower can vary widely depending on project details, but usually fall into a range of USD 50 to 100/MWh [73].

3.2.5 Wind Power

Wind power is a renewable resource. Wind is a form of solar energy. About 2% of the solar radiation that falls on the earth is converted to wind energy in the atmosphere. At any given moment, half of the earth's atmosphere is exposed to the sun, the cyclical heating and cooling transforms the biosphere into a huge heat engine, generating energy, some of which is manifested as wind [10].

Wind power plants convert the air flow energy into electricity. The wind power drives the properly adjusted blades of the turbine rotor and makes them turn. The turning force of the rotor is transmitted via a gear or directly to the electric generator, where direct or alternating current is produced. The installed capacity of the largest wind turbines achieves 5,000 kW.

4 ENERGY BALANCE IN LIBYA

4.1 General information about Libya and energy system

Libya is located in the middle of North Africa on the south side of Mediterranean Sea. with about 1,770 km of coastline. The total area of Libyan land is 1,759,540 square km with a population of about 6,000,000. The Tropic of Cancer passes through the southern part of the country, and the sun shines for a period 3000 to 3500 hours per year, which gives a great opportunity to generate electricity by using solar energy. Most of the territory of the country is desert and therefore no natural rivers have their sources in the country, which means there is no chance to generate hydro electrical power. The population is distribution on this wide geographic area, therefore it is reflected on the electric industry (generation, transmission, distribution) [11][12].

Libya is an important oil country due to having high reserves of oil and natural gas, which are the main sources of energy in Libya. The electrical system in Libya is owned by the General Electric Company of Libya (GECOL). GECOL is responsible for the generation, transmission and distribution of electricity inside the whole of Libya. Electrical networks are connected with neighboring countries (Egypt, Tunisia). GECOL is also responsible for water desalination plants in Libya. The national electrical network is accessible and available for 99% of the population, most of electrical network is concentrated on the coast, where most of the inhabitants live. All electrical power is generated via large central power stations, which are usually built in the coastal areas [11][12].

4.2 Energy situation in Libya

4.2.1 Crude oil

Libya has proven oil reserves of about 43.7 billion barrels, it is 40% of total oil reserves in Africa. National Oil Corporation of Libya plan to increase oil reserve estimates by incentives of additional exploration in both established oil production areas as well as more remote parts of the country. Libya is considered a highly attractive oil producer due to low production costs, being nearest to Europe and the rest of the world for transport and supplying oil. Crude oil produced in Libya has high quality for low sulfur content. Primary energy supply in Libya consists of oil products 90% and natural gas 10% [13].

4.2.2 Natural gas

Libya has proven large natural gas reserves that allow the country to supply to Europe through a pipeline to Italy. The Libyan international oil corporation is responsible for natural gas production and has a monopoly on all new discoveries. As of 2008, Libya had proven natural gas reserve of 1.3 billion tons oil equivalent (toe) [13].

4.2.3 Electricity

As mentioned above, GECOL is responsible for power generation, transmission and distribution in Libya. It owns 100 % of the long-range transmission grid and 90% of the distribution grid. GECOL's power plants produced 25.5 TWh in 2007. The total installed

capacity is approximately 5,440 MW: peak demand in 2007 was 4,420 MW. Energy has increased steadily over recent years and Libya has Africa's highest electricity generation per capita with 4,158 kWh [13].

4.2.4 Renewable energy

About 88% of Libya is considered desert area. The desert is located in the south where there is a high potential of solar energy which can be used to generate electricity by both solar energy conversions, photovoltaic, and thermal methods [14]. In addition in Libya it is possible to generate electricity from wind power, tidal waves [11], although currently the renewable energy sector in Libya quite small, mostly units standing alone (PV systems) to electrify some homes, water pump, use at communication repeaters. The GECOL has started a plan to improve this type of sources contribution for electric generation by 10% at the year 2010, and increase that contribution to 30% at the year 2030, by building large PV plants with grid connection, and building wind farms in coastal area [13].

Solar Energy

The solar radiation in Libya is considered to be very high due to the direct radiation on the horizontal plan. The daily average of solar radiation on the horizontal plane is 7.1 kWh/m²/day in the coastal region, and 8.1 kWh/m²/day in the southern region, with a sun duration of more than 3,500 hours per year. Fig. 4.1 shows the average energy received on the horizontal plane, and Fig. 4.2 shows a map for Libya indicating the radiation level [11].

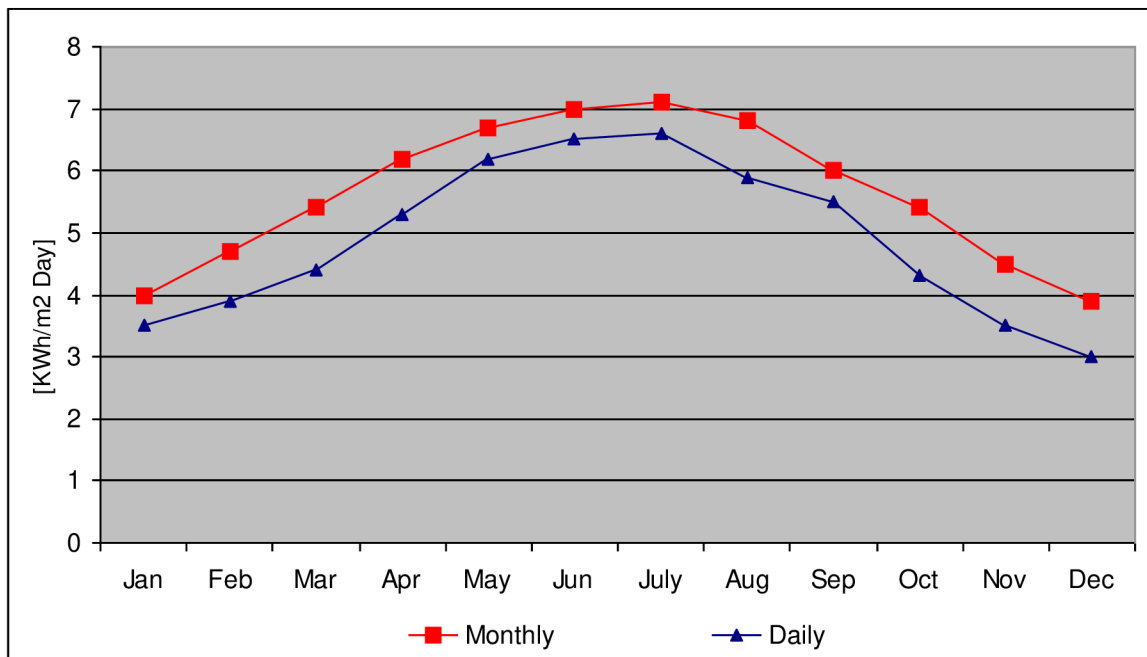

Fig. 4.1 Average monthly, daily solar radiation on horizontal surface [11]

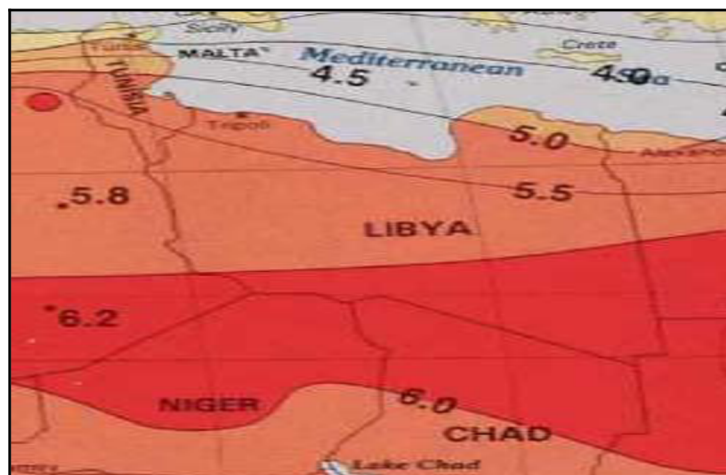

Fig. 4.2 Average global solar radiation on the horizontal plane [11]

Photovoltaic

The photovoltaic conversion of sun energy is well established in many countries. The objective of this technology in terrestrial applications is to obtain electricity from the sun that is cost competitive and has advantages over other energy sources. In the seventies photovoltaic systems were used as a stand-alone in remote areas, but are now widely used connected to the grid.

The use of photovoltaic systems in Libya started in 1976; the first project put into work a PV system to supply a cathodic protection to protect the oil pipe line. Since then the use of photovoltaic systems has become widely used in size and applications as standalone systems. Projects in the field of communication were started 1980 where a PV system was used to supply energy to microwave repeater stations. A project in the field of water pumping was started 1983 where a PV system was used for water system at some oases.

The use of PV system for rural electrification and lighting was started in 2003. The role of PV application has grown in size and type of application, Fig. 4.3 shows typical places for PV systems in Libya and Fig. 4.4 illustrates the use of photovoltaic systems for water pumping [11].

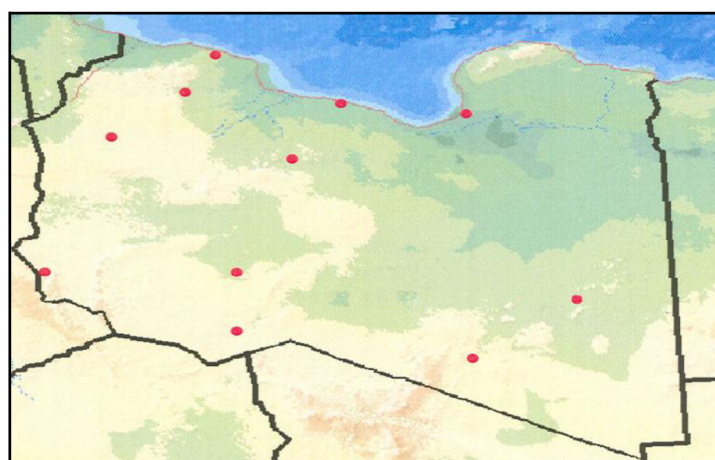

Fig. 4.3 Location of photovoltaic systems [11]



Fig. 4.4 Photovoltaic system for water pumping [11]

Rural Electrification

A problem facing the electrification of all regions in any country is low population areas, away from the electric network. It is extremely expensive to extend high line voltage through desert to electrify a few hundred inhabitants.

The photovoltaic system for ten villages was introduced as a project to electrify remote areas. The installation of the photovoltaic system started in the middle of 2003. The total number of units installed by the general electric company of Libya (GECOL) is 340, with total capacity of 220 kWp, while that which was installed by the Center of Solar Energy Studies (CSES) and Saharan Center is 150 units. The total peak power is 125 kWp [50], others involved in using PV have installed 50 PV units with a total capacity of 60 kWp. In these applications 440 units have been installed with total peak power of 405 kWp, see Fig. 4.5 [11].



Fig. 4.5 Wade Marsite PV Central Plant [11]

Wind power

The measurement of wind showed high of potential of wind energy in Libya, the potential wind energy measured data at a height of 40 m the for coastal areas. The average wind speed is

between 6 - 7.5 m/s. Fig. 4.6 shows average wind speed measured in different locations of the Libyan coast area. The electric company plans to set up wind farms for generating electricity by wind power and start embarking on the implementation of some of these wind farms in different regions in the country and link it to the public network.

Present day trends of the energy production around the world are focused on: high efficiency, low investment, high safety and being environmentally friendly. Tab. 4.1 shows the construction plan for renewable energy plants in Libya in this area.

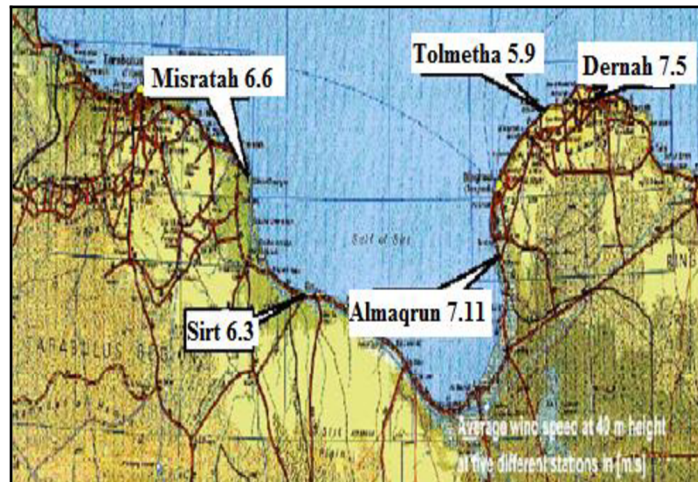

Fig. 4.6 Wind potential for Libyan coast area – average wind speed in m/s [11]

Tab. 4.1 Construction plan for renewable energy plants

Project name	Type	Installed Cap.[MW]	Actual Cap.[MW]	Start year
Daran wind farm 1	Wind	60	6	2009
Trhona wind farm	Wind	50	5	2010
Almagroon wind farm	Wind	120	12	2010
Emselata wind farm	Wind	50	5	2011
Aljofra solar cell	Solar	2	0.2	2010
Green mountain solar cell	Solar	2	0.2	2011
Sabha solar cell	Solar	2	0.2	2011
Total	-	286	29	

Other sources

Other renewable sources are available in Libya, such as geothermal, biomass, tidal waves; all these sources have less potential in Libya.

4.3 Environment

The main emitters of CO₂ in Libya as of 2003, are fuel combustion in the power generation sector 38%, in the transport sector 20% and industry 8%, other sectors represent 34%, in total energy related emissions are responsible for almost 100% of CO₂ emissions in the country, see Fig. 4.7. In 2003 petroleum accounted for more than 60% of carbon emissions in Libya and

natural gas was around 40%. The increasing reliance on natural gas should work to lower carbon emissions. The reason for this increase is attributable mostly to increased energy supply [11].

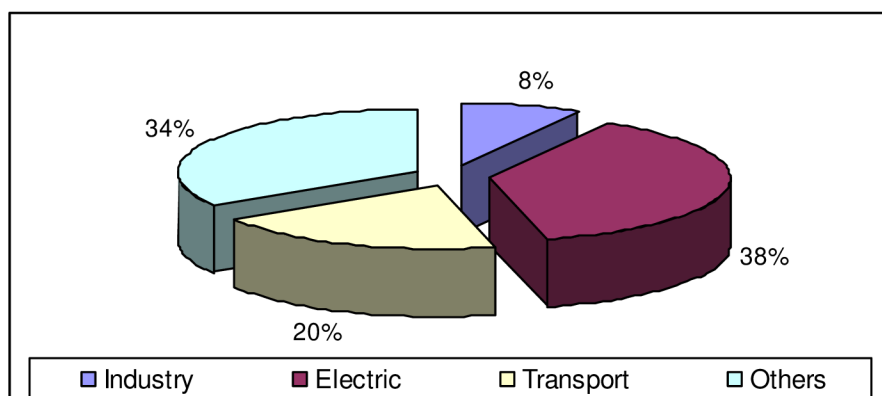

Fig. 4.7 CO₂ Emissions by sectors

4.4 Production of electricity

The production of electrical energy from power plants operating in the public network doubled many times during the period from 1970 to 2008, Tab. 4.2 and Fig. 4.8 illustrate the evolution of energy produced for that period (1970 to 2008). The electrical energy production by type of generation in 2008 was 25.34% for steam units, 34.48% for the gas units and 40.18% for the combined cycle, as shown in Fig. 4.9 [12].

Tab. 4.2 Electrical energy production [GWh]

Year	1970	1980	1985	1990	1995	2000	2001
Energy [GWh]	653	4577	7522	9851	11857	15496	16111
Year	2002	2003	2004	2005	2006	2007	2008
Energy [GWh]	17531	18943	20202	22450	23992	25415	28666

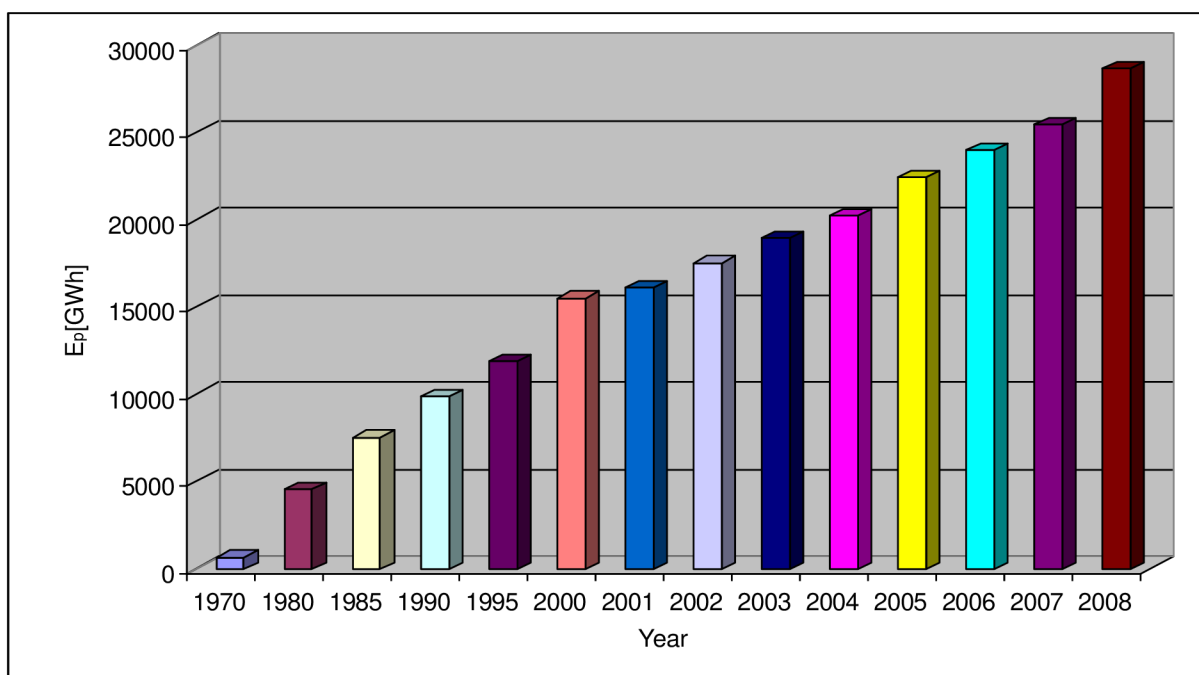

Fig. 4.8 Electrical energy production (1970-2008)

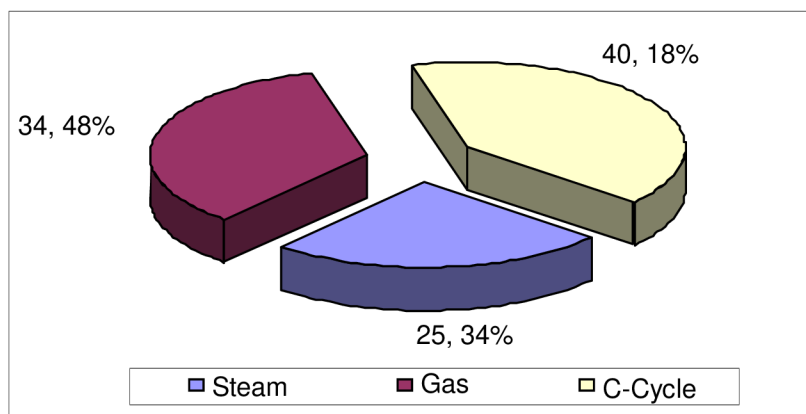

Fig. 4.9 Percentage of electrical energy produced in [MWh], by type of generation (2008)

4.4.1 Structure of consumption

The industrial sector consists of:

- Heavy industries such as steel, cement, etc
- Light industries such as food and textile industry and others
- Oil, gas industry and petrochemical sector, which represents a large industry sector in the country
- Water desalination
- Agriculture sector
- Residential sector

The development of the electrical energy sector has become a trend associated with the economic and social sectors in recent years. The peak load has increased from about 795 MW in 1980, increasing five times approximately to 4 758 MW at the year 2008, the ratio of yearly growth demand on electric power is between 6-10% with an average of about 8% [15][12], Tab. 4.3, and Fig. 4.10 show those increase.

Tab. 4.3 Maximum load in [MW]

Year	1970	1980	1985	1990	1995	2000	2001
$P_{load,max}$ [MW]	151	795	1243	1595	1976	2630	2934
Year	2002	2003	2004	2005	2006	2007	2008
$P_{load,max}$ [MW]	3081	3341	3612	3857	4005	4420	4756

Peak load denotes the maximum requirements of a system at a given time, or the amount of power required to supply consumers at times when need is greatest.

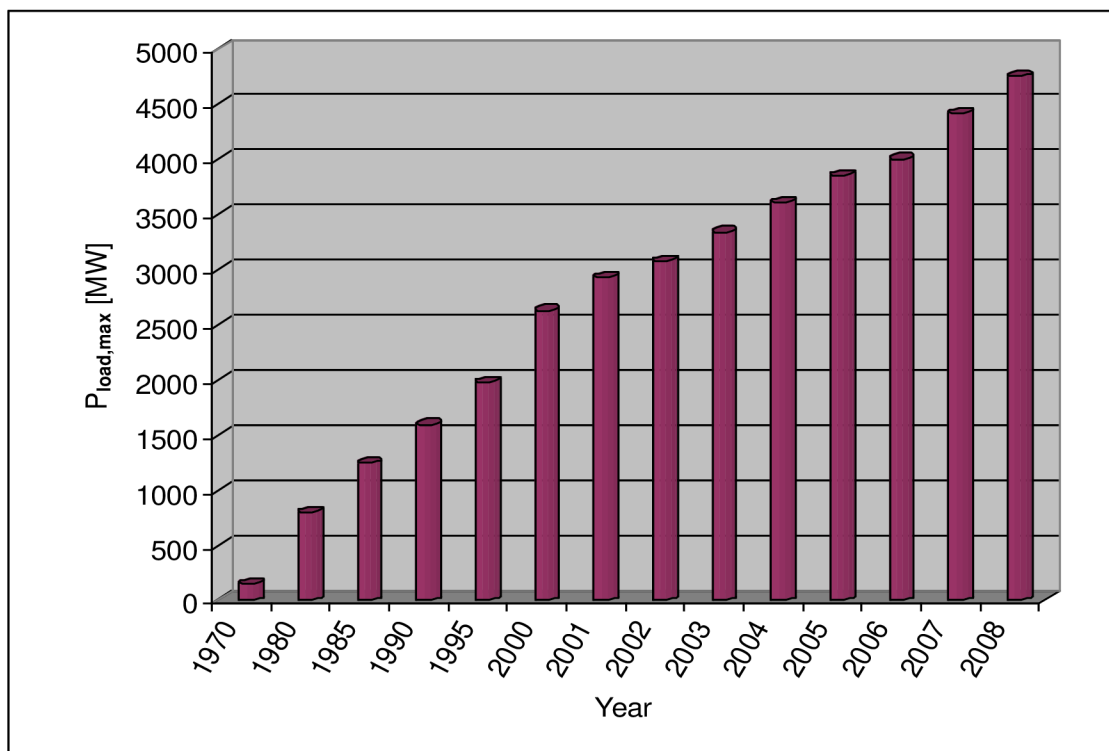

Fig. 4.10 Increasing of maximum load (1970-2008)

Tab. 4.4 and Fig. 4.11 illustrate the yearly maximum and minimum load in MW, on the general network of Libya during the last few years [12] and Fig. 4.12 illustrate the classification of load.

Tab. 4.4 Maximum and minimum load in [MW]

Year	2001		2002		2003		2004	
Load	Max	Min	Max	Min	Max	Min	Max	Min
Total	2934	1453	3081	1505	3341	1321	3612	1312
Year	2005		2006		2007		2008	
Load	Max	Min	Max	Min	Max	Min	Max	Min
Total	3857	-----	4005	1696	4420	1807	4756	1973

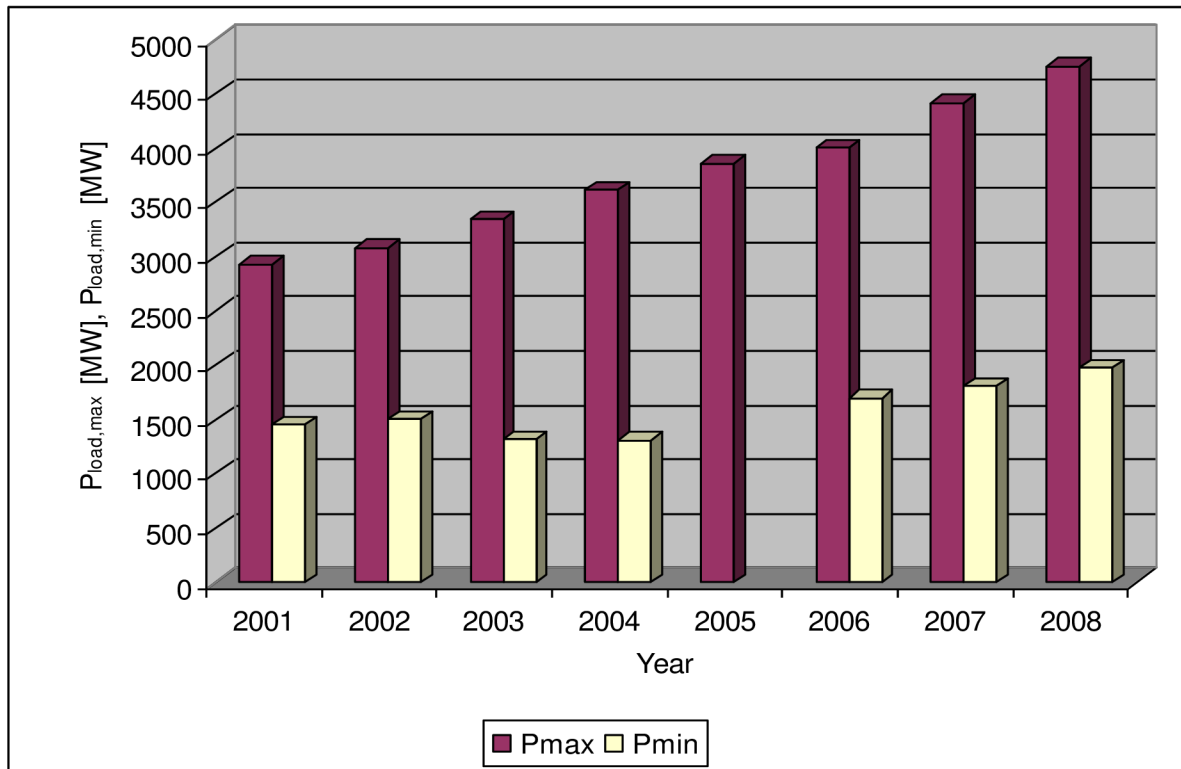

Fig. 4.11 Maximum and minimum load (2001-2008)

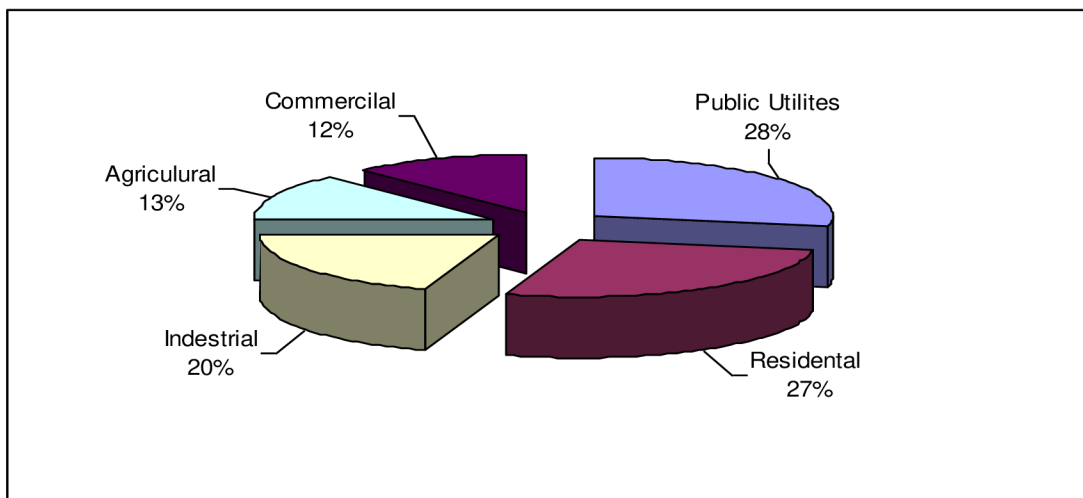

Fig. 4.12 Typical Load classification

4.4.2 Numbers of consumer of electrical energy by type of consumption

The country has witnessed huge development during past three decades; this development is reflected in an increase of electrical consumption in various areas. The numbers of consumers about one million at year 2002, then in year 2008 electric power consumers increased to 1.2 million distributed among eight categories as seen in Tab. 4.5 and Fig. 4.13, while Tab. 4.6 and Fig. 4.14 illustrate the total energy consumed during the year 2008 and the percentage of consumption by type of consumer.

The residential sector represents 28% of total consumption followed by street lighting 16%, large industry 14%, commercial 13% etc [12].

Tab. 4.5 Number and type of consumers in Libya at year 2008

Type of customer	Numbers of customer
Residential	902,063
Small agriculture	112,901
Large agriculture	814
Small industry	60,685
Large industry	35
Commercial	124,615
Street lighting	5,023
State offices	18,055
Neighborhood countries	2
Total	1,224,193

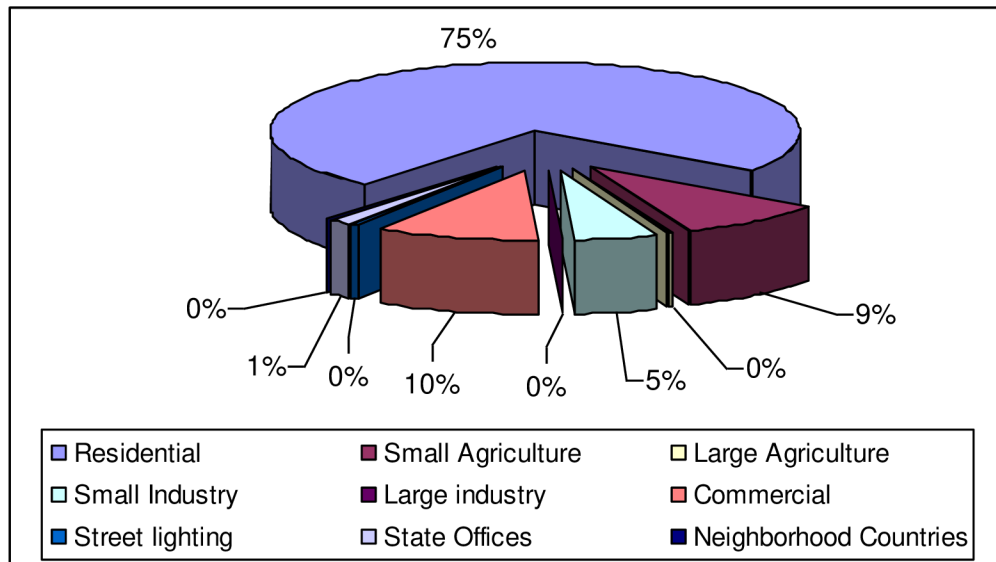

Fig. 4.13 Number of electric consumers in Libya 2008

Tab. 4.6 Electrical energy consumed in Libya at year 2008

Type of consumption	The amount of consumption [MWh]	Percentage [%]
Residential	5,222,432	28
Small agriculture	1,047,571	6
Large agriculture	1,183,413	6
Small industry	615,407	3
Large industry	2,560,555	14
Commercial	2,400,148	13
Street lighting	2,930,554	16
State offices	2,374,618	13
Neighborhood countries	116,894	1
Total	18,451,592	100

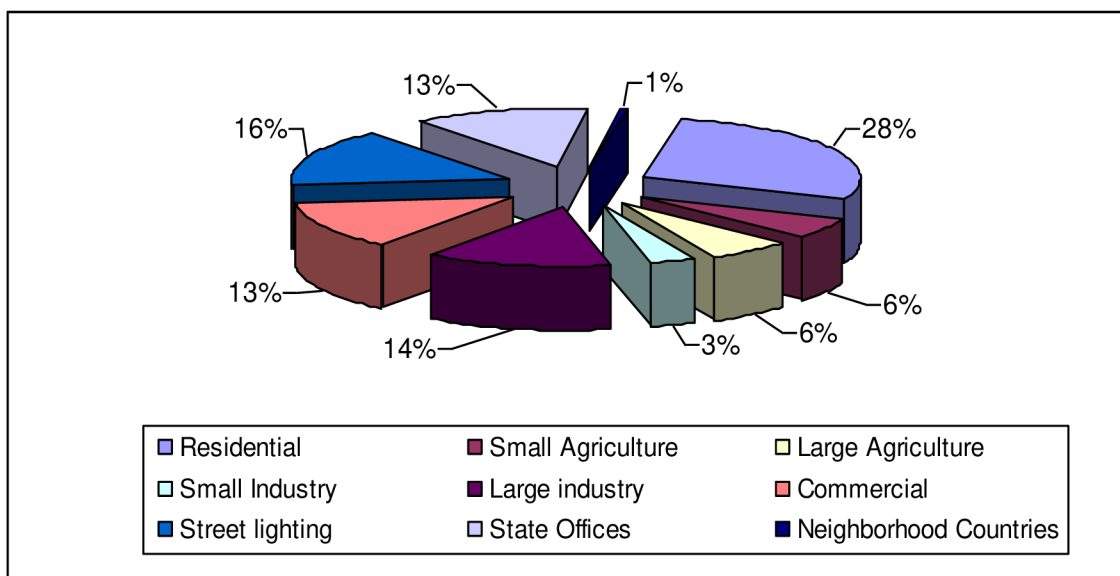

Fig. 4.14 Electric energy consumed in year 2008

4.4.3 Evolution and average of power consumption per capita

Lifestyle have evolved, and people have become used to many electrical devices in their daily activities, such as air conditioners, water heaters, lights, space heaters etc, which is reflected in a significant increase of percentage of electricity consumption per capita. The ratio of electric power consumption per capita in Libya has increased from about 330 kWh/c in 1970 to 4 360 kWh/c in 2008 [11][12], Tab. 4.7 and Fig. 4.15 illustrate that change.

Tab. 4.7 Annual consumption per capita

Year	Annual consumption [kW/h]	Percentage of grow[%]
1996	2674	---
1997	2715	2
1998	2837	4
1999	2939	4
2000	3024	3
2001	3040	1
2002	3196	5
2003	3336	4
2006	3696	---
2007	4158	---
2008	4360	5

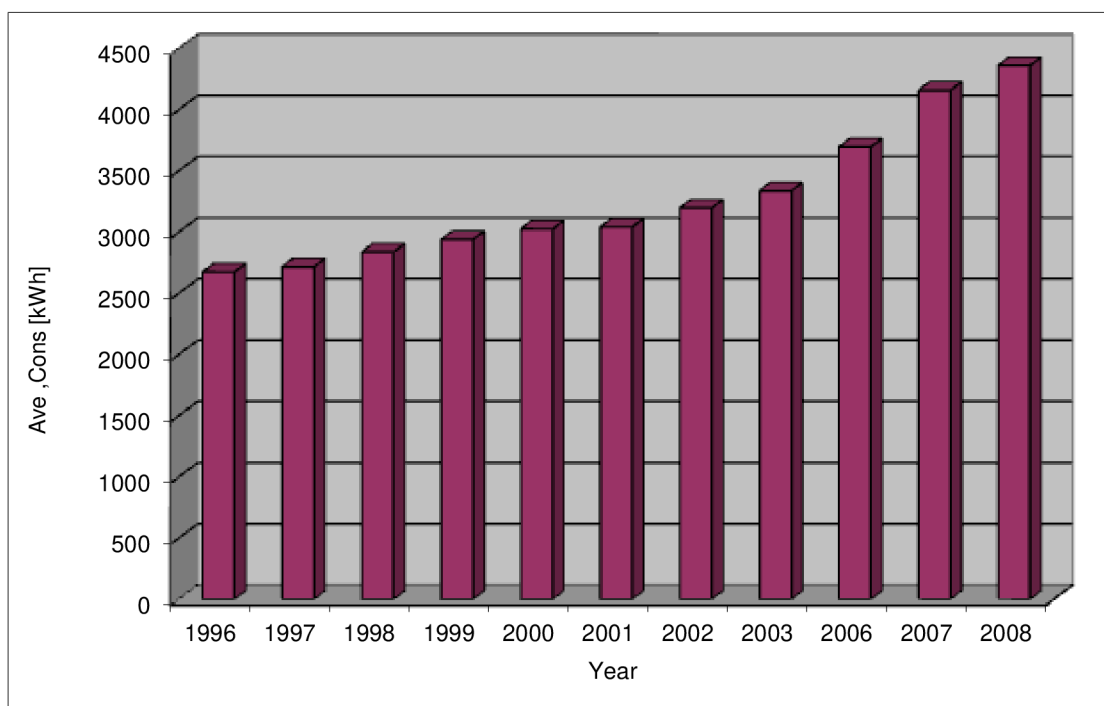

Fig. 4.15 Average of energy consumption per capita in Libya

The Libyan network has been linked with Egyptian and Tunisian networks on a high voltage 220 kV system, the power exchanged between Libya, Egypt and Tunisia is illustrated in Tab. 4.8, and Tab. 4.9. For the already finished and completed study of development of the linkage to the 400 kV high voltage system between Egypt and the Arab Maghreb countries (Libya, Tunisia, Algeria, Morocco), see Fig. 4.16 [12], for more details about Libyan network see appendix 3.

Tab. 4.8 Libyan-Egyptian interconnection network

Year	Energy Bought [MWh]	Energy Sold [MWh]	Energy Imported [MWh]	Energy Exported [MWh]
2007	1875	6612	77020	103887
2008	3305	12520	68681	116864
2009	49010	8810	128981	113270
1 Jan-30 Jun 2010	1200	21990	34412	78026

Tab. 4.9 Libyan-Tunisian interconnection network

Year	Energy Bought [MWh]	Energy Sold [MWh]	Energy Imported [MWh]	Energy Exported [MWh]
2007	0	0	0	0
2008	0	0	0	0
2009	46054	0	0	0
1 Jan-30 Jun 2010	0	0	0	0

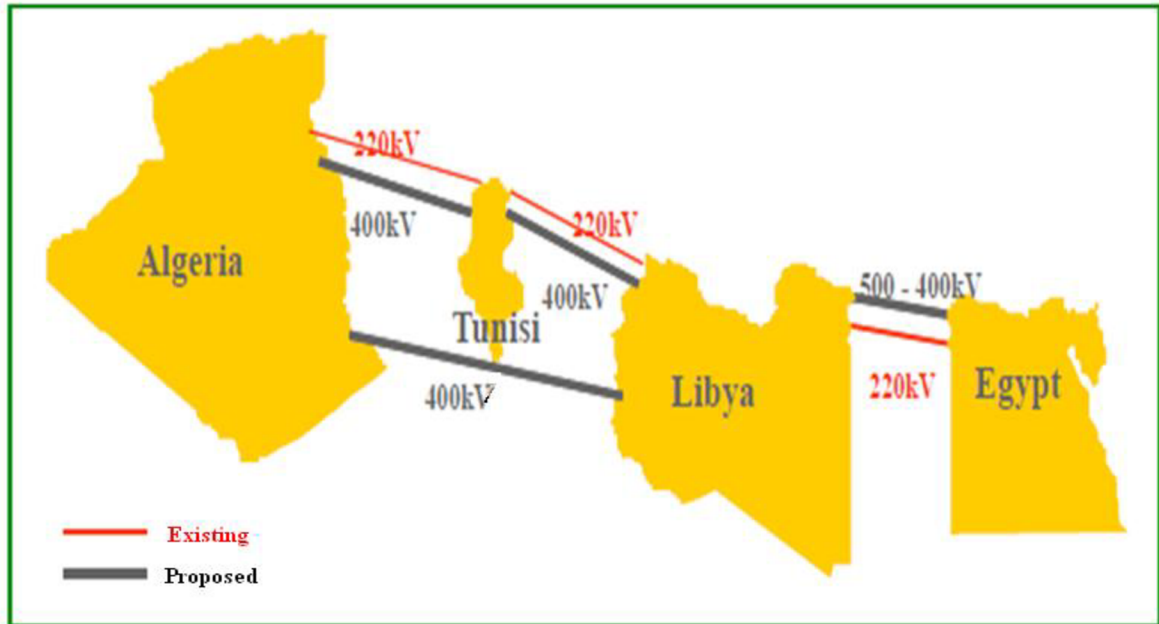

Fig. 4.16 Existing and planned interconnection [72]

4.4.4 Daily load curve characteristics of the Libyan network

A typical daily load curve of the Libyan network is shown in Fig. 4.17. The full day is divided into two periods; the first period extends from midnight to midday and the second period after midday to midnight. The analysis of these two periods is as follows:

Peak load (P1) and minimum load (M1) in first period.

Peak load (P2) and minimum load (M2) in the second period.

(P1) is effected by industrial and commercial load.

(P2) is often effected by the time of sunset, where street lighting loads and residential loads start dramatically increasing along with the rest loads.

It is clear from the load curves that the differences between the peak load (P2) and the minimum load (M1) is expressed in load factor (LF) which usually averages somewhere between (60-63)% and is almost constant in the day-to-day load curves [15]. And Fig. 4.18 show maximum and minimum load while Fig. 4.19 show daily curve of maximum and minimum load at year 2008.

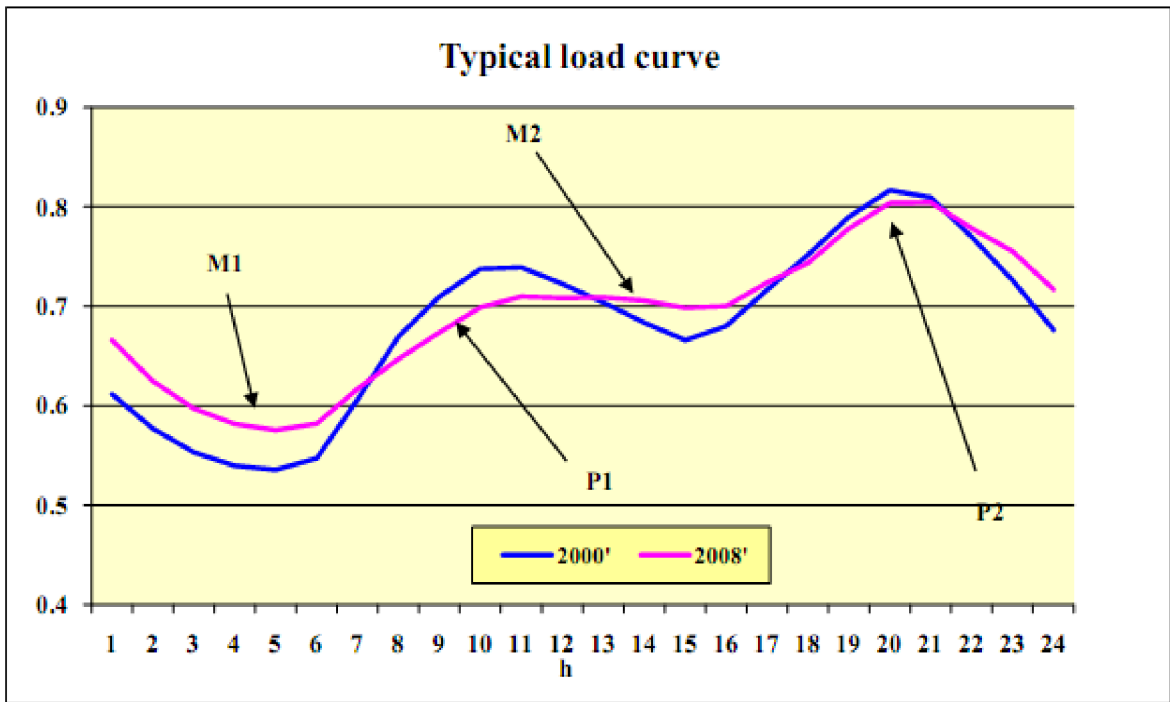

Fig. 4.17 Typical normalized daily Load curves for years 2000 & 2008. The normalization factor is the peak load within the respective year [15]

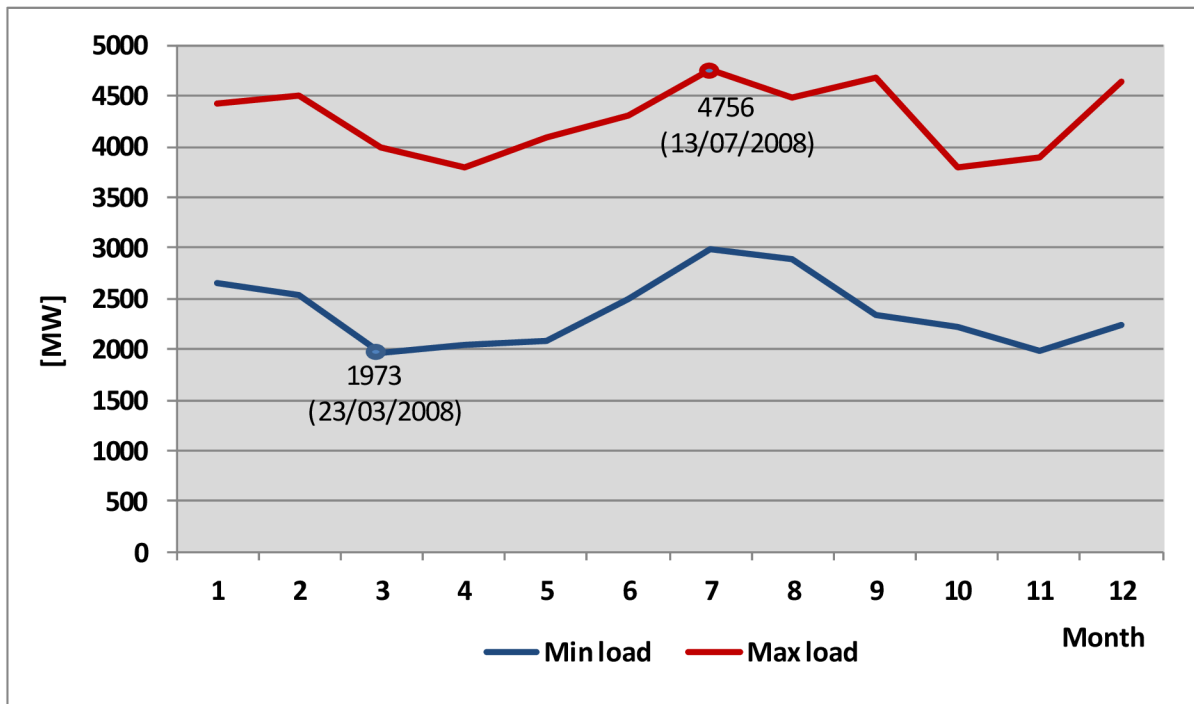

Fig. 4.18 Maximum and minimum load in 2008

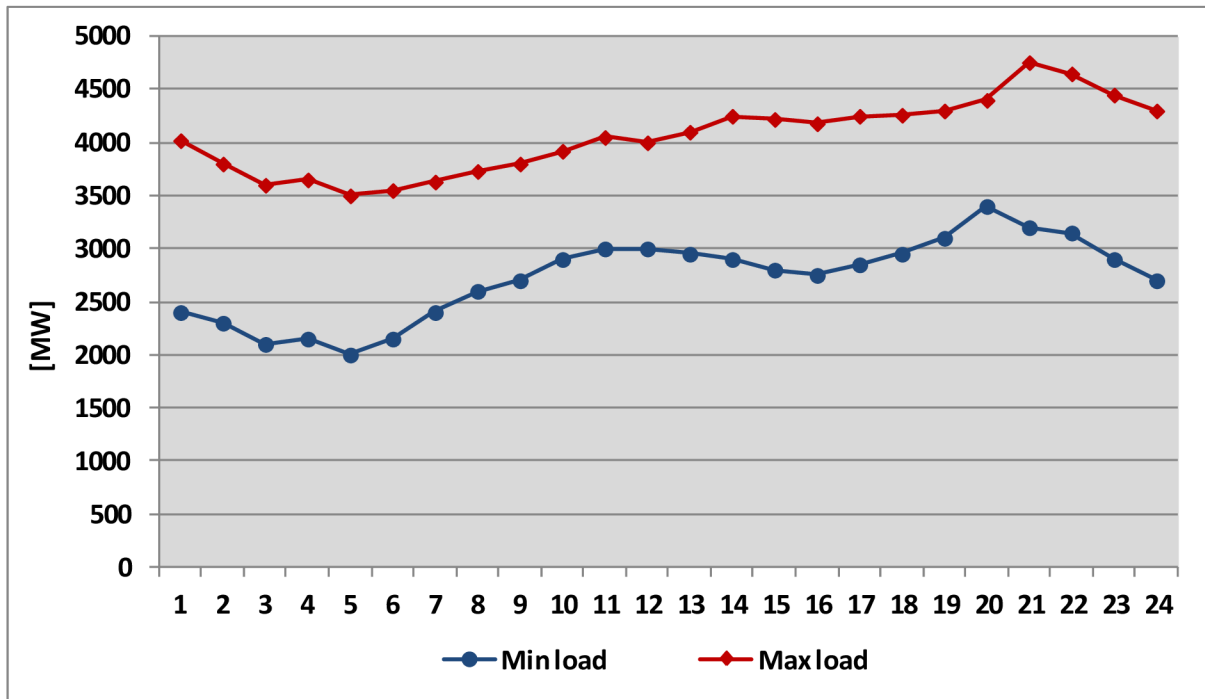

Fig. 4.19 Daily load curve of the maximum and minimum load in 2008

5 THE ANALYSIS OF ENERGY DEMAND

The ability to forecast long-term electricity demand is a fundamental prerequisite for the development of a secure and economical power system where the demand forecast is used as a basis for system development. Overestimation of demand may lead to unnecessary investment in transmission and generation facilities. This results in the construction of unnecessary infrastructure, which will impose additional costs on all customers. On the other hand, underestimation of demand may lead to shortages in supply and infrastructure. Both extremes are undesirable for an electricity industry, particularly in an emerging market such as Libya. It can also directly affect the economy as a whole [16].

Three final objectives for demand forecasting in this section comprise of:

- Peak Load forecasting from 2008 to 2025
- Forecasting the regional peak load from 2008 to 2025
- Forecasting the consumption, by sectors, from 2008 to 2025

The target of study forecasts, the future electricity demand by national peak load, regional peak load, and consumption by sectors. The regions are divided into 6 provinces, Sectors are divided into parts such as residential, commercial, large industrial, small industrial and agriculture.

Analysis in this chapter studies the effects of the factors, such as GDP, temperature and population etc. It conducts sensitivity analysis with more sophisticated scenarios corresponding to high or low forecast scenarios using GDP and population [16].

5.1 Scenario approach

Owing to inevitable uncertainties with regard to future developments, it is generally acknowledged that an analysis and assessment of such developments should not rely on a single result. Analysis should be based on several scenario cases that might reflect possible deviations from the results of the main scenario, and thus depict a kind of corridor for future development. Consequently according to reference [16], three scenarios have been defined in the context of this work, comprising:

Main demand: this scenario provides information on the development of the future power demand that is considered most likely;

“High” demand: this scenario describes the development of future power demand based on a very favorable evolution of the economic and demographic framework and assumptions of important variables that shape the forecast;

“Low” demand: this scenario depicts future power demand in an unfavorable evolution of important assumptions and the overall framework

"Mega Project is delayed": this scenario explains the effect of future power demand when Mega Project is delayed [16].

Overview of Mega Project

The Libyan government has designed a country development plan called “Mega Project”, with 8 projects from 2008 to 2019, which is shown in Tab. 5.1. The commercial sector is going to be developed as the largest sector in of the project. A new housing project will be conducted in six areas (Green Mountain, Benghazi, Middle Region, Tripoli, South, and West).

Tab. 5.1 Mega Project Plan

Project	Sector	Period
New housing project	Residential sector	2008-2016
Industrial project	Industrial sector	2009-2018
Foreign Investors project 1	Commercial sector	2009-2013
Foreign Investors project 2	Commercial sector	2009-2019
Tourism project	Commercial sector	2009-2013
Universities	Commercial sector	2008-2013
Transportation	Commercial sector	2009-2013

5.2 Description of input data

5.2.1 Input data

In general, electricity demand is determined by economic income factors, represented by GDP, population, etc. This is a generally accepted definition of demand function. In a modern economy, electricity is necessary to the production process and for daily human activities. It is not a tangible commodity. As a result, a number of important, sometimes countervailing factors change the pattern of electricity demand. Therefore, factors affecting economic activities and consumption patterns will have an important impact on electricity. Regarding consumption, the following factors have been identified for their significant contribution to long-term electricity demand in Libya [16].

5.2.2 Peak load

Peak load denotes the maximum power requirements of system at a given time, or the amount of power required to supply customers at times when need is greatest. It can refer either to the load at a given moment (e.g. a specific time of day) or to an averaged load over a given period of time [16].

Peak load data is appropriate for adapting the time series model as it does not consider losses such as technical loss and commercial loss, which means the amount of input data is reduced. In order to estimate a model, all input data must be from the same time period and interval. Hence, monthly peak load from 1995 to 2007 was used.

5.2.3 Real GDP

Using real term data is more economically reasonable as the inflation value is not stable. The tariff in 1950, for instance, is underestimated because of inflation. Hence, for long term analysis, GDP data is used in real terms [16].

Tab. 5.2 Real GDP (%) [16]

year	1997	1998	1999	2000	2001	2002	2003	2004	2005	2006	2007
GDP	1.7	1.8	-0.4	1.1	4.5	3.3	9.1	4.6	3.5	5.6	6.0

In addition, inflation is an important factor for electricity consumption, as it impacts on customer purchase power and electricity tariffs. These are reflected in a production cost changed by inflation. So, inflation should be in the forecasting model.

Moreover, the used forecast GDP, provided by the ministry of planning, which is 6% from 2007 to 2012 and 6.5% from 2013 to 2026, Fig. 5.1 show the historical movement of peak load and real GDP [16].

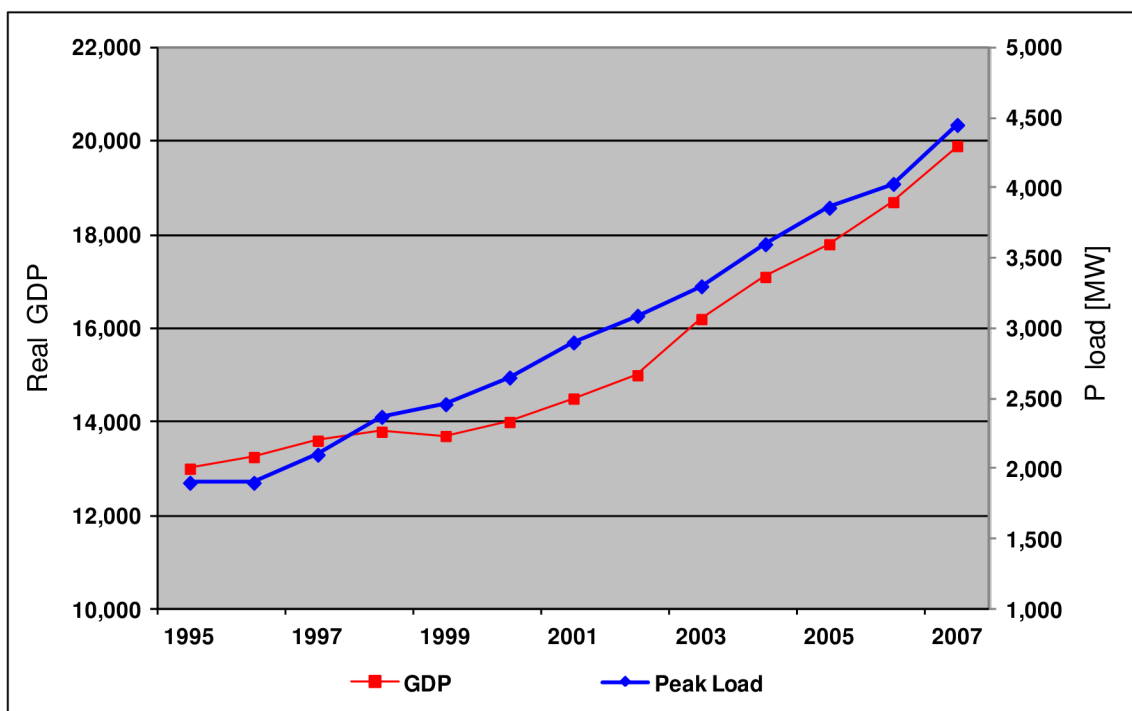
**Fig. 5.1 Peak load (MW) and real GDP (Million Libyan Dinar) [16]**

5.2.4 GDP of sectors

GDP of sectors is forecast using real GDP from 1990 to 2025. Tab. 5.3 shows categories of sectors.

Tab. 5.3 Categories of sectors [16]

Sector	Included category
Agriculture	Agriculture, fishing and forestry
Small industry	Non-oil
Large industry	Forming industry, manufacturing
Commercial	Tertiary industry, construction

With each category the GDP for sector is forecast using the following equation.

$$\text{Sectorial } GDP(t)^i = \beta^i \cdot \text{totalGDP}(t) \quad (5.1)$$

Where, (i) is the category of the sector and total GDP is forecast GDP in 5.2.3 and (t) is time series and β is the regression coefficient

Previous studies and various indicators proved that the best correlation of small industry is the non-oil sector. This is caused by the fact that small industry has a strong relation with the category use of the number of households, because the main component of small industry is the production and supply of construction related to household demand. Tab. 5.4 shows the result of the regression analysis production [16].

Tab. 5.4 Regression analysis results [16]

Sector	Result
Agriculture	$0.0855 \times \text{total GDP}(t)$
Small industry	$0.6996 \times \text{total GDP}(t)$
Large industry	$0.0538 \times \text{total GDP}(t)$
Commercial	$0.5555 \times \text{total GDP}(t)$

5.2.5 Population

Population growth is the one of important factors in determining electricity demand. Higher population growth is expected to increase electricity consumption more rapidly. A positive correlation between population growth and electricity demand is expected. Fig. 5.2 shows the positive relationship between population and peak load.

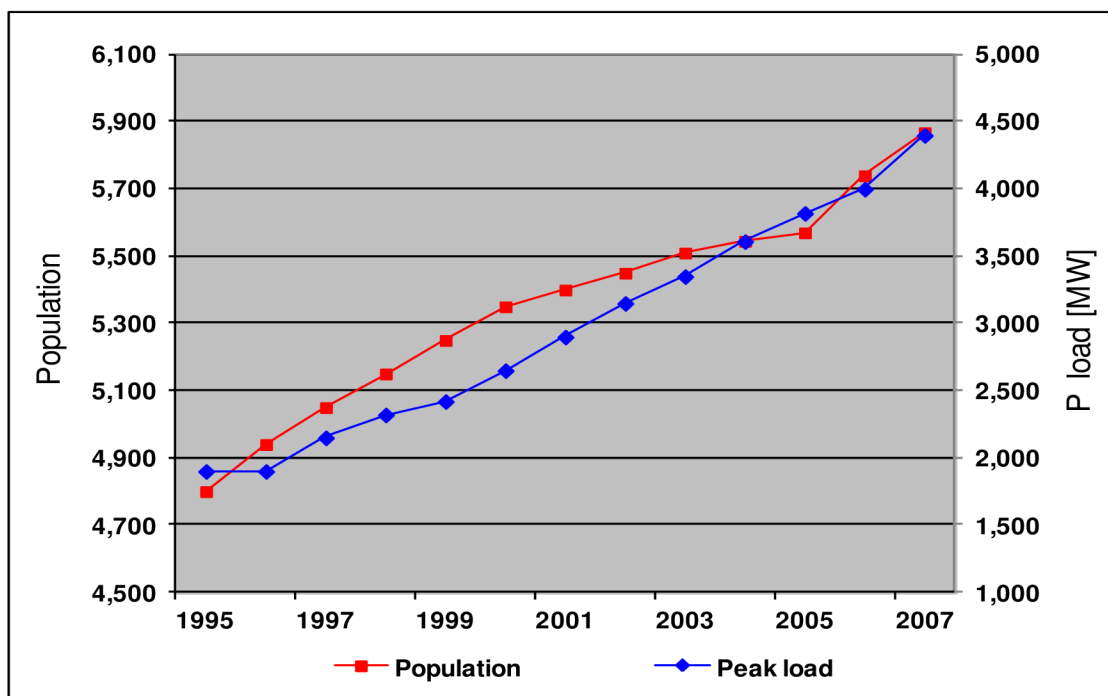

Fig. 5.2 Population (Thousand) and Peak load [MW] [16]

Only three population data points, 1984, 1995, 2006 from Libyan censi are not sufficient to estimate its growth rate, there for population data from 1960 to 2005 taken from a census by United Nations is used. The past population growth is as follows [16]. See Tab. 5.5

Tab. 5.5 Libyan population (units: 1,000) [16]

Year	1960	1965	1970	1975	1980	1985
Population	1,349	1,623	1,994	2,466	3,063	3,850
Year	1990	1995	2000	2005	2006	2007
Population	4,363	4,832	5,345	5,596	5,673	5,792

The Libyan census includes foreigners in Libya; the foreigners should be included in the population as they too use electricity. In addition, there is enough real data and the movement of past 50 years is stable. In other words the data is reliable. Considering this pattern and data, the trend extrapolation method is appropriate.

Tab. 5.6 Forecasted population (units:1,000) [16]

Year	2008	2009	2010	2011	2012	2013	2014	2015	2016
Population	6,006	6,143	6,280	6,383	6,486	6,588	6,691	6,794	6,897
Year	2017	2018	2019	2020	2021	2022	2023	2024	2025
Population	7,000	7,103	7,206	7,309	7,412	7,515	7,618	7,721	7,824

5.2.6 Households

The strongest factors regarding the effect of households are population and income level. Domestic requirements are directly proportional to population growth unless the number of persons per house-hold increases. Empirically, the number of persons per household seems to decrease when a person's income level rises. The GDP and the population are expected to keep growing. Thus the number of households is predicted to increase. The historical number of households is as shows at Tab. 5.7 [16].

Tab. 5.7 Historical households (units: 1) [16]

Year	1984	1995	2006
Number of households	554.000	721,358	963,889
Persons per household	6.3	6.7	5.9

The average growth rate of households from 1984 to 1995 is 2.43% and from 1995 to 2006 is 2.67%. The growth rate for both periods is 9.93%. as population and GDP growth are constant, the growth rate of households is expected to be constant. Consequently, the growth rate for 11 years is assumed to be 9.93% [16].

Tab. 5.8 Forecasted households (units: 1,000) [16]

Year	2008	2009	2010	2011	2012	2013	2014	2015	2016
Households	1,021	1,051	1,082	1,113	1,146	1,180	1,214	1,250	1,287
Persons per household	5.9	5.8	5.8	5.7	5.7	5.6	5.5	5.4	5.4
Year	2017	2018	2019	2020	2021	2022	2023	2024	2025
Households	1,325	1,367	1,412	1,457	1,504	1,553	1,603	1,655	1,708
Persons per household	5.3	5.2	5.1	5.0	4.9	4.8	4.8	4.7	4.6

5.2.7 Temperature

In order to obtain temperature response function, temperature density and temperature effects, the maximum and minimum demands are higher in summer and winter than spring and fall, which are attributed to summer cooling loads caused by using air-cooling equipments, and to winter heating loads caused by various electric heating apparatus, daily data between 1997 and 2007 was used. For national temperature effects, average temperature weighted by regional sales was used.

Temperature is a deterministic variable and if it increases the explanatory power of the model, then the variable should be in the model, even though the coefficient test is failed under the conditions of a 95% of confidence interval [16].

5.2.8 Inflation

As the result of hypothesis test for inflation, it was found that the coefficient is zero on the condition of a 95% confidence interval. However, it was added to GDP as real term is economically more reasonable [16].

5.3 Scenario analysis

In demand forecasting sensitivity analysis is implemented in order to determine the various unexpected uncertainties in the demand with regard to future economic development [16]. (This part was quoted from KEPCO study and rewritten as in the source)

5.3.1 Low demand

GDP and population growth rate are 10% lower than base demand. Scenario 1 assumes that the average growth rate of the GDP and population would be much lower than at present, the level of available income would be lower, job opportunities would become scarce and the unemployment rate would rise. In the public sector, fiscal revenues would increase much more slowly than expected or even decrease, which would lead to a large national budget deficit and, at least in the mid-term, to reduced spending for infrastructure measures and other public activities.

Furthermore, if population growth rate decreased then the total amount of electricity consumption would decrease and the total number of electricity users would also decrease. This factor is more likely to have an impact on the residential sector.

The general notion for scenario 1 is that less favorable economic development conditions in the future are more difficult to achieve and less likely to occur than improvement of the expected development conditions [16].

5.3.2 High demand

GDP and population growth rate are 10% higher than base demand. In scenario 2, the average growth rate of the GDP and population would be above present expectations. Consequently, personal income would rise and more money would be available for private consumer spending. Also, the public would be better off as a result of increased revenues. Therefore, public spending for infrastructure and other activities could increase. The level of production in the commercial and industrial sector would be higher as additional electricity would be required.

5.3.3 Delayed Mega Project

The purpose of scenario 3 is to determine the various unexpected uncertainties in the demand if the mega project is delayed. Mega Project is an important factor of future peak demand as approximately 44% of peak demand is accounted for it in 2018. On the other hand, the delay of the Mega Project influences peak demand directly. For the analysis, it is assumed that GDP and population are fixed and the maximum delay is two years.

5.3.4 Result of scenario analysis

As the result of scenario analysis 1 and 2, the gap between high demand (19,045 MW) and low demand (17,823 MW) is about 1,200 MW in 2025, whereas the gap between high demand and base demand (18,417MW) is around 600 MW in 2025. The gap is likely to be covered as the amount of the gap is small compared to total peak load. Consequently, it is important to construct the power plant following the power expansion plan [16].

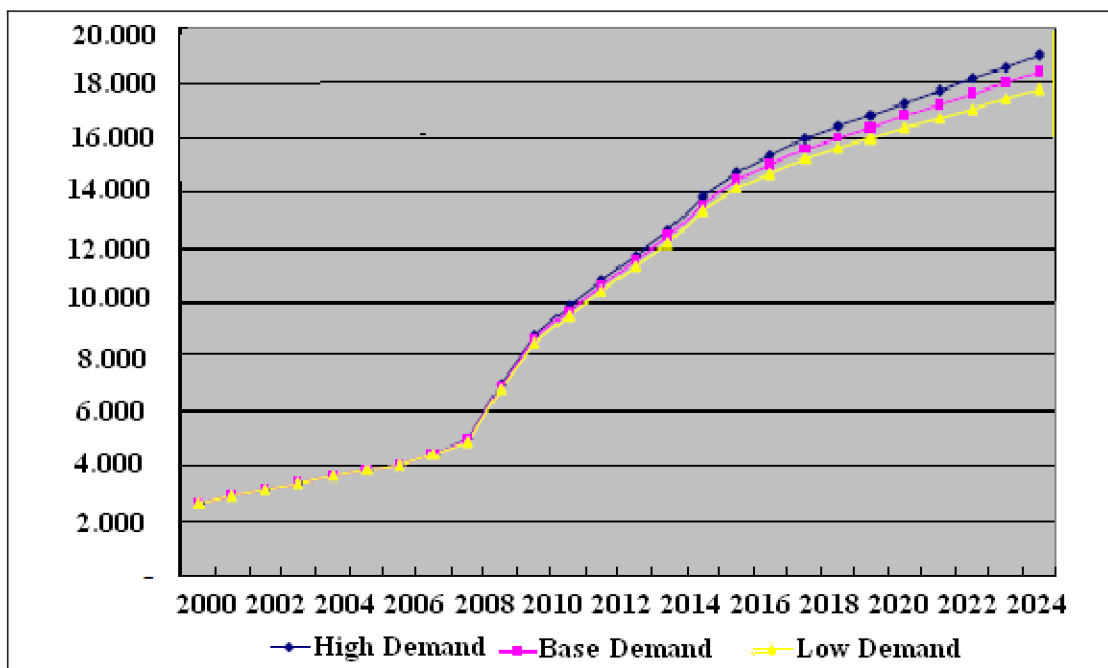

Fig. 5.3 Scenario analysis [MW] [16]

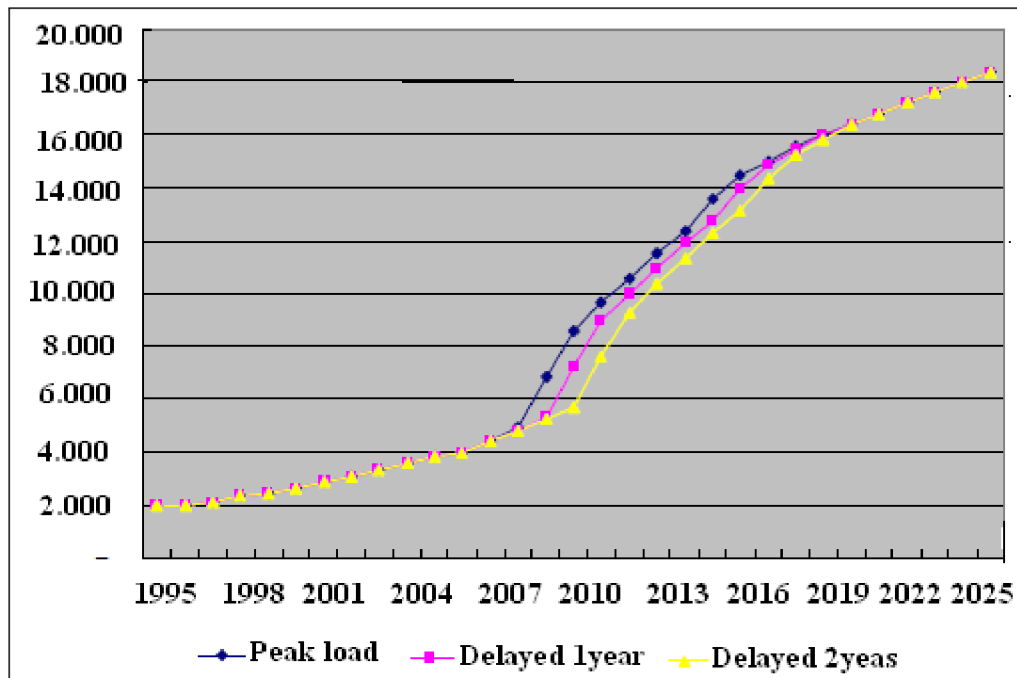

Fig. 5.4 Scenario analysis (Mega Project is delayed) [MW] [16]

According to the scenario analysis 3, the delay of the Mega Project would have a significant influence to peak load. If the Mega Project is delayed for one year, the peak load in 2010 (7,247 MW) will be approximately 1,400 MW lower than base demand (8,621 MW). If the delay is two years, the peak load in 2010 will be about 2,900 MW lower than base demand. However, a delay of the Mega Project does not seem to cause such a big problem as the amount of peak load of general consumption. On the other hand, the power shortage is not caused by a delay of the Mega Project.

Demand analysis indicated a trend that power supply in Libya is expected to increase from 4,420 MW in 2007 to 18,417 MW in 2025 (including the Mega Project – 6,876 MW) and total consumption will reach approximately 70,000 GWh in 2025. Furthermore, it is forecast that the peak load will occur in summer, especially in August from 2013 as the cooling load is expected to be higher than the heating load. According to the input factor analysis, demand is increased 3.22% due to the GDP and 4.64% due to the population when 1% of either factor increases. In addition, electricity use rises rapidly when temperatures are higher than 30 degrees or lower than 15 degrees [16].

6 THE OBJECTIVES OF THE THESIS

Practically only conventional power plants are used in Libya. The main aim of this thesis is the analysis of possible use of the waste heat energy for heating of domestic hot water, space heating, and for driven cooling equipments (absorption chiller) for air conditioning in the summer season.

The solution is divided to the four main parts:

A. SOURCES

- a. Conventional power plants (fuels, types, properties, parameters, efficiency)
- b. Cogeneration power plants (fuels, types, properties, parameters, efficiency)

B. NETWORKS

- a. Heating distribution networks (central heating – types, properties, parameters, efficiency)
- b. Electrical distribution networks (properties, efficiency)

C. CONSUMPTION

- a. Typical family house (typical consumption of hot water, heat, cold including powers)
- b. Use of electricity for covering of the necessities of a typical house
 - Heating
 - Hot water
 - Cooling
 - Average yearly consumption of electricity
- c. Using of heat for covering of the necessities of a typical house
 - Proposal of the concept (approach)
 - Design of the components of the system
 - Average yearly consumption of heat

D. EVALUATION

- a. Properties of each system
- b. Economical evaluation (house, all systems)

7 CONVENTIONAL THERMAL POWER PLANTS

Thermal power plants are one of the main sources of electricity in both industrialized and developing countries, typically realized as a large central power station; more than half of the electricity generated in the world is by using fossil fuels as the primary fuel. Conventional power plants usually convert one third of fuel used to generate power and the rest of the fuel is lost as heat to the atmosphere, often via a cooling tower. Electricity generation in thermal power plants is characterized by the main source of generation being firing fossil fuels such as coal, natural gas or petroleum (oil). Steam is produced in a boiler, and it drives a turbine connected to an alternator. Heat energy is converted to electric energy within the so-called steam cycle.

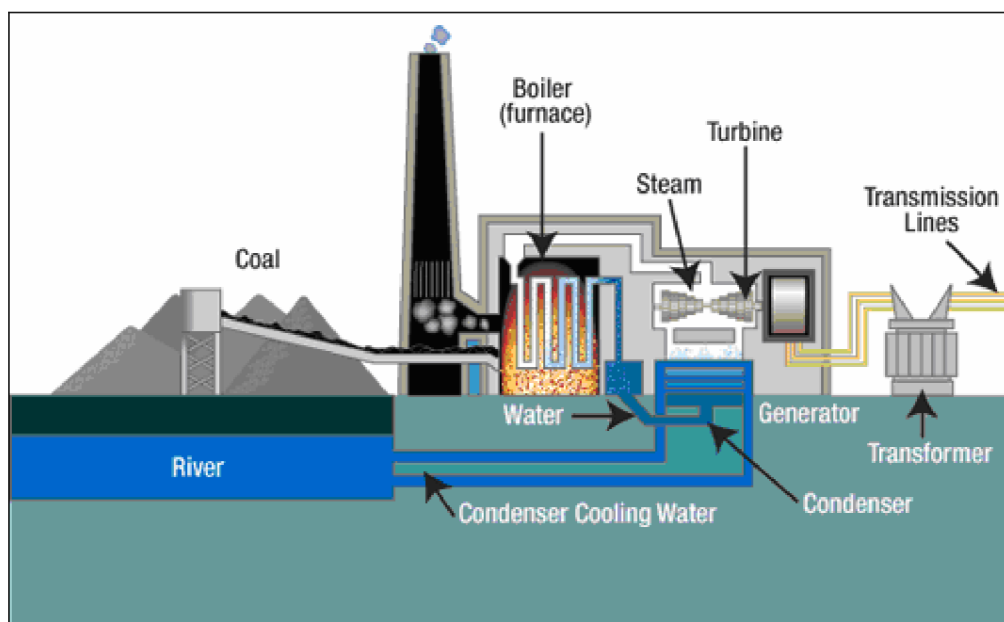

Fig. 7.1 Coal Fired Thermal Power Plant [60]

A thermal power plant is usually defined by the type of fuel used to heat the water and create steam. Coal, oil, and even solar and nuclear powers can be used to create the steam necessary to run a thermal power plant. Fig. 7.1 shows a coal thermal power plant.

The energy efficiency of a conventional thermal power station, considered as saleable energy as a percent of the heating value of the fuel consumed, is typically 33% to 48%. This efficiency is limited as all heat engines are governed by the laws of thermodynamics. The rest of the energy must leave the plant in the form of heat. This waste heat can go through a condenser and be disposed of with cooling water or in cooling towers. An important class of thermal power station is associated with desalination facilities; these are typically found in desert countries with large supplies of natural gas and in these plants, freshwater production and electricity are equally important co-products.

The Carnot efficiency dictates that higher efficiencies can be attained by increasing the temperature of the steam. Sub-critical fossil fuel power plants can achieve 36–40% efficiency. Super critical designs have efficiencies in the low to mid 40% range, with new "ultra critical"

designs using pressures of 4400 psi (30.3 MPa) and multiple stage reheating reaching about 48% efficiency. Above the critical point for water of 705 °F (374 °C) and 3212 psi (22.06 MPa), there is no phase transition from water to steam, but only a gradual decrease in density [17].

The net electric efficiency (η_e) of a generator can be defined by the first law of thermodynamics as net electrical output (W_E) divided by fuel consumed (Q_{Fuel}) in terms of kilowatt hours of thermal energy content.

$$\eta_e = \frac{W_E}{Q_{Fuel}} \quad (7.1)$$

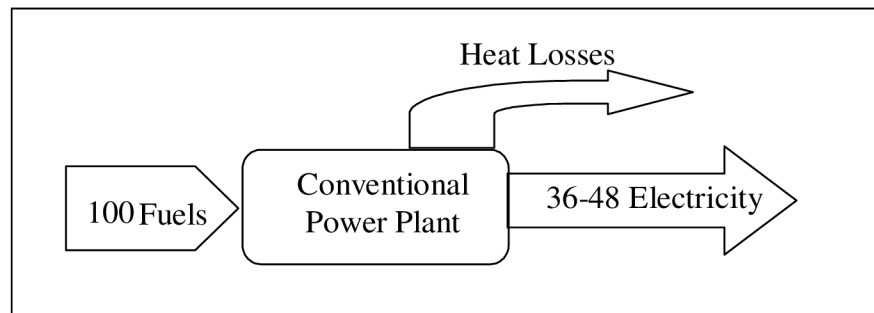

Fig. 7.2 Simple scheme for conventional power plants

Total Efficiency

$$\eta_{tot} = \frac{36}{100} = 0.36 \Rightarrow \eta_{tot} = 36\%$$

8 COGENERATION (CHP)

Cogeneration is simultaneous production of electrical or mechanical energy and useful thermal energy from a single energy source such as oil, coal, natural or liquefied gas, biomass, or solar [18]. In conventional electricity generation, only a small portion of fuel energy is converted into electricity and the remaining is lost as waste heat.

Cogeneration reduces this loss by recovering part of this. Principal applications of cogeneration include industrial sites, district heating and buildings [19].

Cogeneration allows the producer to have his own electricity, hot water and steam, if he needs to. In this way, cogeneration reduces the site's total outside purchased energy requirements and this reduction on energy use compared to independent heat and electricity generation, may, in return, reduce the total cost of utility services, and also the fuel resources. Also the distribution losses, which are an important problem, will be decreased.

Cogeneration is the best means of converting energy source into heat and power coupled with the CO₂ reduction potential. Higher fuel consumption efficiencies are gained from producing electricity and, importantly, utilizing the by-product, heat, for use in district heating systems or for individual homes. Other uses include the use of heat or steam for industry such as the paper or steel industry for steam and laundry or hotels for heat.

Cogeneration, simply put, is an opportunity to control and reduce energy costs. Basically, a cogeneration system takes heat that would normally be wasted and uses it to satisfy some or all of the thermal energy requirement. Fig. 8.1 shows simple concept of cogeneration.

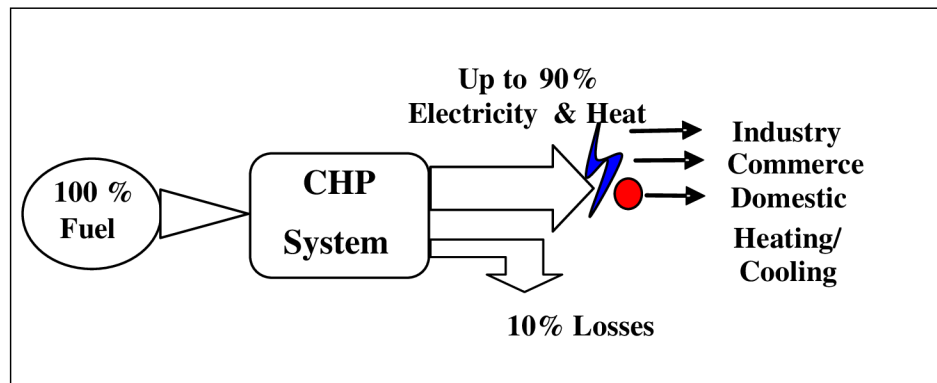

Fig. 8.1 Schematic diagram of Cogeneration (CHP) [20]

Although cogeneration has widely been employed for both enhancing the plant profitability and increasing the overall energy efficiency, it is, however, difficult to justify traditional cogeneration in tropical locations since there is little need for the heat produced. Improving system performance and finding new alternative uses or applications of the heat produced from cogeneration are a great challenge. Cogeneration plants usually operate with low capacity during the no heating season or in the summer period as there are no or fewer heating needs. Consequently, this causes the cogeneration plants to be operated at relatively low capacity and low efficiency. Therefore, it is very important to conduct a comprehensive study and establish

new applications of the heat produced during this period e.g. using heat as energy carrier for distributed small-scale thermally driven machines. Finding new alternatives for energy applications from waste, like the implementation of thermally driven cooling processes via absorption cooling, is very attractive [18].

8.1 Cogeneration System

A typical cogeneration system consists of a prime mover where fuel is converted to mechanical power and heat. This comprises a steam turbine or combustion turbine that drives an electrical generator, a waste heat exchanger (heat recovery system) that recovers waste heat from the engine and/or exhaust gas to produce hot water or steam, a heat rejection system, an electrical and mechanical interconnection between the co-generator and the energy user, and a control system, See Fig. 8.2

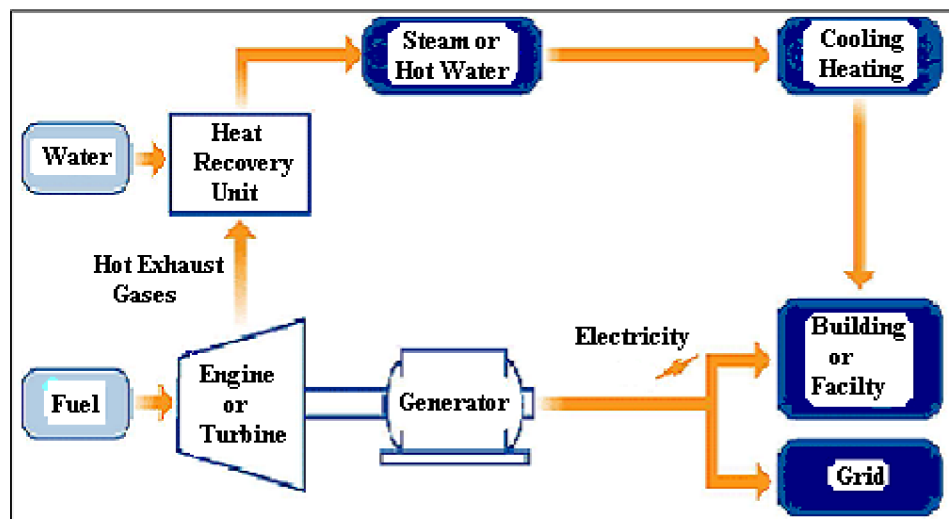

Fig. 8.2 Cogeneration with prime mover gas turbine or engine [21]

In a cogeneration system, the engine is usually used to drive an electric generator. The fuel is converted to electricity at an efficiency ranging from 25% to 30%. However, unlike the central power plant, a cogeneration plant should be located near a user of heat whose requirement will be satisfied by the heat rejected in the engine exhaust and cooling water. Cogeneration system design represents a balance between a number of technical and economic factors. Choice of the prime mover, availability of spare parts and the condition of existing utility and mechanical/electrical systems, and reliable service are the most important factors that are to be considered [18].

Cogeneration produces a given amount of electric power and process heat with 10% to 30% less fuel than it takes to produce the electricity and process heat separately [18].

8.1.1 The components for a cogeneration system

- **Prime Mover**

The common feature in all cogeneration systems is the prime mover. It is the heart of the cogeneration system which converts fuel into mechanical energy. The choice of the prime mover

depends on the site's heating and operating requirements, equipment availability and fuel availability.

- **Heat Recovery Steam Generator (HRSG)**

The heat recovery steam generator (HRSG) takes the hot exhaust gases from the turbine and water from the waste water treatment plant to produce steam.

- **Steam Turbine**

A steam turbine is an excellent prime mover to convert heat energy of steam to mechanical energy. It is one of such well-known prime movers as gasoline engines, diesel engines, gas turbines, jet engines, etc [18].

- **Generator**

A generator converts energy from mechanical form to electric form. Generators are driven by gas or steam turbine, wind, etc, to produce electricity. The AC synchronous machine is the most common technology for generating electric energy.

8.1.2 Thermal energy storage

Since a cogeneration power plant produces hot water continuously, hot water can be stored in tanks to meet all demands. Thermal energy is also used for cooling applications. However, using storage tanks for heating applications with low temperature hot water (85°C to 90°C) can save available waste heat, thus meeting on-site power generation requirements.

Since it is not economical to store electric power (especially for small cogeneration power plants), excess thermal energy must be stored to ensure a high thermal cogeneration efficiency to meet electrical power needed.

Using full waste heat in cogeneration applications for central air-conditioning requires that heat-operated chillers be operated at maximum capacity and all excess cooling capacity is stored as chilled water in storage tanks.

8.2 Heat to Power Ratio

Combined heat and power (CHP) is the production of electricity and heat in one single process for dual output streams. Natural gas is often selected as the fuel for CHP systems. There are two common ways to define the energy content of fuel: higher heating value (HHV) and lower heating value (LHV).

Turbine, microturbine, engine, and fuel cell manufacturers typically rate their equipment using lower heating value (LHV), which accurately measures combustion efficiency; however, LHV neglects the energy in water vapor formed by combustion of hydrogen in the fuel. This water vapor typically represents about 10% of the energy content. LHVs for natural gas are typically (33.53×10^6 to 35.37×10^6 J/m³). Consumers purchase natural gas in term of its HHV.

Heat-to-power ratio is one of the most vital technical parameters influencing the selection of cogeneration system. If the heat-to-power ratio of industry can be matched with the characteristics of the cogeneration system being considered, the system optimization would be achieved in a real sense.

The definition of heat-to-power ratio is thermal energy to electrical energy required by the industry. Basic heat-to power ratios of the cogeneration system variants are shown in Tab. 8.1 below along with some technical parameters. The steam turbine based cogeneration system can be considered over a large range of heat-to-power ratios [22].

The available heat utilization from a cogeneration system is dependent on the cogeneration technology but also on the heat quality (supply and return pressures and temperatures) requirements. Low temperature hot water systems (90/50°C) could result in overall efficiency of 90% (based on LHV), while steam supply (5 to 20 bar saturated) would lead to lower efficiency (60 to 70%) [23].

The power-to-heat ratio measures the amount of electricity that could be produced from certain heat generation capacity or actual heat demand, but tells nothing about the overall efficiency and the fuel utilization. In an efficient cogeneration system, both power-to-heat ratio and overall efficiency are important deciding parameters [23].

$$\text{Electric efficiency} \quad \eta_e = Q_e / Q_{fuel}$$

$$\text{Heat Efficiency} \quad \eta_{heat} = Q_{heat} / Q_{fuel}$$

$$\text{Overall efficiency} \quad \eta_{tot} = (Q_e + Q_{heat}) / Q_{fuel}$$

They called cogeneration efficiency or total efficiency

$$\text{Power to heat ratio} \quad \alpha = Q_e / Q_{heat}$$

Where

$$Q_e = \text{Gross electrical output, kW}_e$$

$$Q_{heat} = \text{Useful heat output, kW}_{th}$$

$$Q_{fuel} = \text{Fuel energy input, kW}_{th}$$

Tab. 8.1 Cogeneration prime mover

Prime Mover	Fuel Used	Size range (MWe)	Heat Power Ratio	Electrical Generating Efficiency	Typical Overall Efficiency	Heat Quality
Pass out steam Turbine	Any fuel	1 to 100	3:1 to 8:1	10 - 20%	Up to 80%	Steam
Back pressure steam turbine	Any fuel	.05 to 500	3:1 to 10:1	7 - 20%	Up to 80%	Steam
Extraction steam turbine	Any fuel	0.5 to 500	1:1 to 10:1	20- 47%	73-90%	Hot water
Combined cycle gas turbine	Gas and oil	3 to 300	1:1 to 3:1	35- 55%	73-90%	Steam Hot water
Open cycle gas turbine	Gas and oil	0.25 to 50	1:5:1to 5:1	25 - 42%	65-87%	Steam Hot water
Compress Ignition engine	Gas and oil	0.2 to 20	0.5:1to 3:1	35 - 45%	65 – 90%	Steam Hot water
Spark ignition engine	Gas and oil	0.003 to 6	1:1 to 3:1	25 - 43%	70 -90%	Hot water

8.3 Simple Comparison between cogeneration and separate production of electricity and heat

Conventional power plants usually convert one third of fuel used into utilizable power and the rest of fuel is lost as heat to the atmosphere. Cogeneration uses both electricity and heat and therefore can achieve an efficiency of up to 90%, giving energy savings between 15-40% when compared with the separate production of electricity from conventional power stations and of heat from boilers. It is the most efficient way to use fuel.

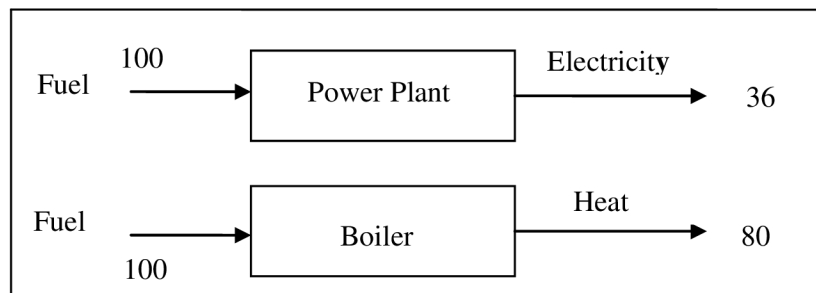
**Fig. 8.3 Separate production of electricity and heat [23]**

Total efficiency of separate production

$$\eta_{tot} = \frac{36 + 80}{200} = 0.58 \Rightarrow \eta_{tot} = 58\%$$

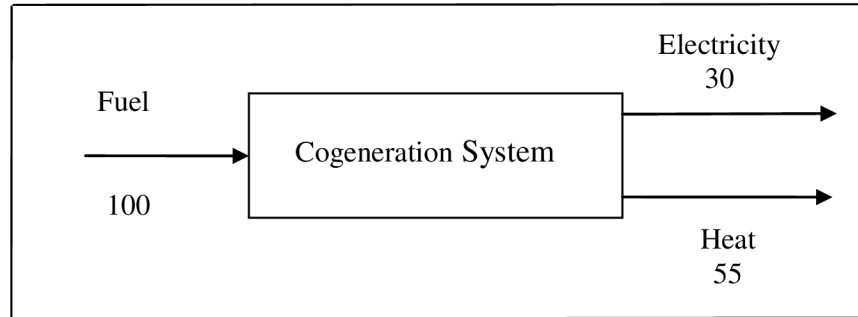

Fig. 8.4 Cogeneration (CHP) production of electricity and heat [23]

Total efficiency of combined heat and power system

$$\eta_{CHP} = \frac{30 + 55}{100} = 0.85 \Rightarrow \eta_{CHP} = 85\%$$

8.3.1 General benefits for cogeneration system and main potential advantages

Cogeneration compared to separate generation of electricity and heat, results in fuel saving in the range of 25 – 33 %, for the same amount of total electrical and heat generation. The advantages of fuel saving will lead to:

- Fuel cost reduction
- Environmental benefits (CO₂ mitigation and emission reduction) [23].

Cogeneration normally means decentralized power generation, which leads to:

- Reduced grid losses (5-10%) – further fuel saving.
- Increase power supply security.
- Utilization of local fuel.

9 TRI-GENERATION (CHCP)

Tri-generation or combined cooling, heat and power (CHCP) can be defined as combined heat and power production with additional production of cooling. The primary source of energy is usually natural gas or oil. Tri-generation refers to the production of three energies: electricity, heat and chilled water. See Fig. 9.1

Tri-generation units offer significant relief in electricity grids during the hot summer months. Cooling loads are transferred from electricity to fossil fuel grids, since the cooling process changes from the widespread compression cycles to the absorption ones. This further increases the stability of electricity grids and improves system efficiency, since summer peaks are served by electric companies through inefficient stand-by units and overloaded electricity transmission lines [24].

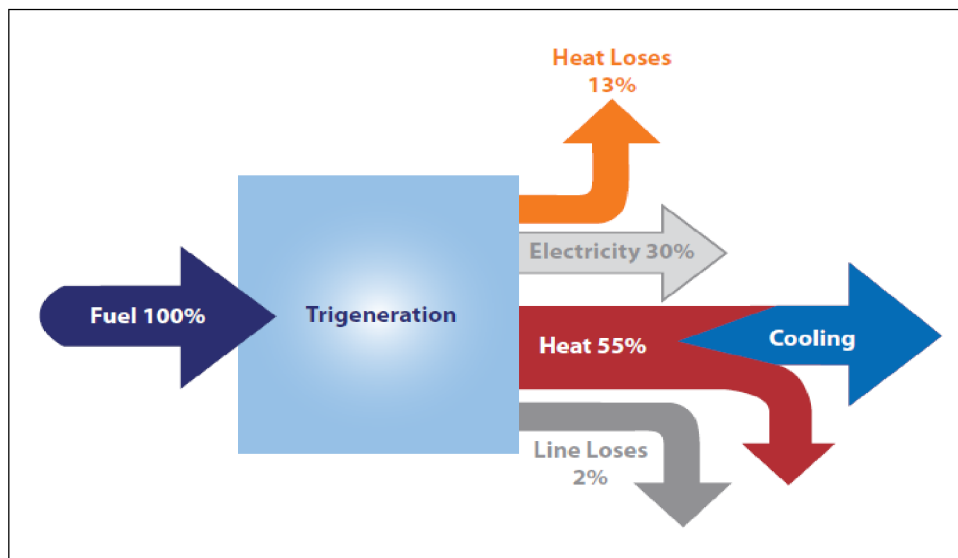

Fig. 9.1 Schematic diagram of Tri-generation process [24]

Introducing an absorption chiller into a cogeneration system means that the site is able to increase the operational hours of the plant with an increased utilization of heat, particularly in summer periods.

The cooling requirements of buildings can be met using a variety of cooling systems. Electrically driven compressor chillers are the most popular, although the last decade has seen a rapid increase in the number of absorption chillers, which can use many different energy sources including energy-poor sources. As an alternative solution for satisfying the cooling demands of buildings and improving the cogeneration efficiency, steam and hot-water driven absorption chillers can be included in tri-generation plants [26].

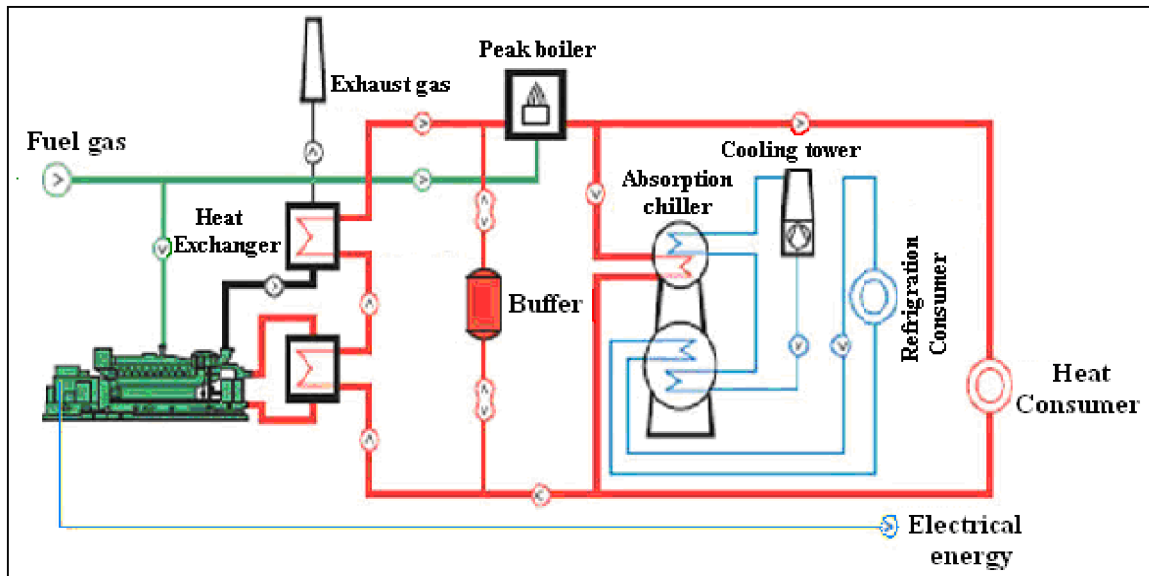

Fig. 9.2 Schematic showing overall tri-generation system configuration [24]

Chilled water is achieved by incorporating an absorption chiller into a cogeneration system. Absorption chillers take the waste heat from a cogeneration plant to create chilled water for cooling a building [25].

A typical tri-generation system CHCP is shown in Fig. 9.3. It is comprised of a gas engine, a generator and an absorption chiller. The engine is driven by natural gas and the mechanical energy is further changed into electricity power by the generator. At the same time, the absorption chiller to generate cooling power in summer and heating power in winter utilizes exhaust gas and jacket water derived from the engine. If waste heat from the engine is not enough for users, a combustor in the absorption chiller can burn natural gas as a supplement. Thus, the energy demands of cooling, heating and electrical power in a building or a district can be met by this system simultaneously [27].

Compared with the energy supply mode of a large centralized power plant and local air-conditioning system, distributed CHCP systems will receive more attention. Therefore, along with the developing tendency and promising prospects, the CHCP systems possess some advantages which traditional energy supplies do not share.

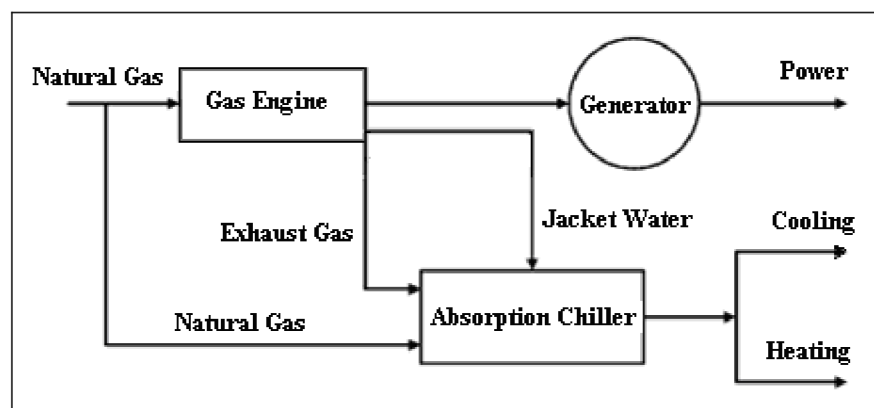

Fig. 9.3 Typical CHCP system [27]

First, overall fuel energy utilization has dramatically improved, ranging from 70% to more than 90% compared with 30–45% of typical centralized power plants. In general, less primary energy is needed to obtain the same amount of electricity and thermal energy. In addition to the saving in primary energy, vast reductions in net fuel costs, trans-mission and distribution savings can be achieved.

A typical CHCP system consists of five basic elements: the prime mover; electricity generator; heat recovery system; thermally activated equipment and the management and control system. According to current technologies, options in prime movers can be steam turbines, reciprocating internal combustion engines, combustion turbines, micro-turbines, Stirling engines and fuel cells; the last three prime movers are relatively new technologies developed in last decade. Any of these options can be selected to meet diverse demands and limitations from site-to-site, especially local heat and electricity profiles, regional emissions and noise regulations and installation restrictions. Thermally activated equipment is another part of CHCP systems, which provide cooling or dehumidification. Commercialized thermally activated technologies include absorption chillers and desiccant dehumidifiers; moreover, novel adsorption chillers currently almost entirely for commercial use can be another choice for small CHCP systems. Some existing systems also apply electric chillers, or engine-driven chillers integrated with prime movers, to fulfill cooling demands, which, combined with thermally activated technologies, are the cooling or dehumidification options of CHCP systems in some of the literature [27].

Different prime movers, connecting with different cooling or dehumidification options, can result in various kinds of CHCP systems in theory, but only several modes of combination are widely adopted in commercial markets; other promising possibilities are being investigated to overcome technological or economic problems [27].

Brief introductions follow and major parameters and performance of these prime movers can be referenced in Tab. 9.1 [27].

- **Steam Turbines**

Steam turbines are the most common technology used in power plants and industries. Depending upon the exit pressure of the steam, steam turbines fall into two types: back-pressure turbines and condensing turbines. Backpressure turbines operate with an exit pressure at least equal to atmospheric pressure, and are suitable for some sites with a steam demand of intermediate pressure. Condensing turbines have the advantage of changing electrical and thermal power independently and they work with an exit pressure lower than atmospheric pressure. In theory, steam turbines equipped with a suitable boiler can be run on any kind of fuel. As a mature technology, steam turbines have an extremely long life and, with proper operation and maintenance, are very reliable. However, several problems limit their further application, which include low electrical efficiency, slow start-up time, and poor partial load performance. As a result, steam turbines are more popular in large central plant utilities or industrial cogenerations than in distributed energy applications [27].

- **Reciprocating internal combustion engines**

Two types of internal combustion engines are currently in use; spark ignition engines, which are operated mainly with natural gas (although biogas or landfill gas can also be used); and compression ignition engines, which can use diesel fuel, as well as other petroleum products, such as heavy fuel oil or biodiesel. Reciprocating engines are a proven technology with a range of size and the lowest first capital costs of all CHCP systems. In addition to fast start-up capability

and good operating reliability, high efficiency at partial load operation give users a flexible power source, allowing for a range of different energy applications, especially emergency or standby power supplies. Reciprocating engines are by far the most commonly used power generation equipment under 1 MW.

Although they are a mature technology, reciprocating engines have obvious drawbacks. Relatively high vibrations require shock absorption and shielding measures to reduce acoustic noise. A large number of moving parts and frequent maintenance intervals increase maintenance costs, strongly offsetting fuel efficiency advantages. In addition, full utilization of the various heat sources with diverse temperature levels in CHCP applications is difficult [27].

- **Combustion turbines**

Combustion turbines are frequently used prime movers in larger-scale cogenerations due to their high reliability and large range of power. Sets smaller than 1 MW have so far been generally uneconomical because of their low electrical efficiency and consequent high cost per kWe output.

Combustion turbines are easier to install than steam turbines and they have the added benefit of being less area intensive, with lower capital costs; maintenance costs are slightly lower than reciprocating engines, but so is their electrical efficiency. Emissions are somewhat lower than that of reciprocating engines, and cost-effective NO_x emissions-control technology is commercially available. Combustion turbine exhaust (typically around 540°C) can be used to support the combustion of additional fuel. This technology is called supplementary firing, and it can raise the temperature of exhaust gas more than 1000°C and increase the amount of high-pressure steam produced. Using produced steam to power a steam turbine is known as a combined-cycle gas turbine (CCGT), with higher net electrical efficiency (35–55%), which is appropriate for public utility companies and industrial plants. The major disadvantage of combustion turbines are that combustion turbines require premium fuels, especially natural gas, which historically have high price volatility; the high temperatures involved lead to demanding standard of materials with higher production costs; additionally, turbine performance is significantly reduced at higher altitudes or during periods of high ambient temperatures [27].

- **Micro-turbines**

Micro-turbines extend combustion turbine technology to smaller scales. They are primarily fuelled with natural gas, but they can also operate with diesel, gasoline or other similar high-energy fuels.

Micro-turbines have only one moving part; they use air bearings and they do not need lubricating oil, although they have extremely high rotational speed, up to 120,000 rpm.

A striking characteristic is their flexibility, in that small-scale individual units can be combined readily into large systems of multiple units. Additionally, there are environmental advantages, such as lower combustion temperatures assuring low NO_x emissions levels and less noise than an engine of comparable size [27].

This technology has been commercialized only recently and is offered by a small number of suppliers. The main disadvantages at this stage are its short track record and high first costs compared with reciprocating engines. Other issues include relatively low electrical efficiency and sensitivity of efficiency to changes in ambient conditions.

Micro-turbines can be used as a distributed energy resource for power producers and consumers, including industrial, institutional, commercial and even residential users of electricity in the future.

Moreover, the heat produced by a micro-turbine can be used to produce low-pressure steam or hot water for on-site requirements.

- **Stirling engines**

Compared to a conventional internal combustion engine, a Stirling engine is an external combustion device. In the cycle, media, generally helium or hydrogen, is not exchanged during each cycle, but within the device, while the energy driving the cycle is applied externally. Stirling engines can operate on almost any fuel (gasoline, alcohol, natural gas or butane), with external combustion that facilitates the control of the combustion process and results in low air emissions, low noise and a more efficient process. In addition, best in class machines have fewer moving parts compared to conventional engines, limiting wear on components and reduce vibration levels.

Stirling engine technology is still in its development; no statistical data on availability is therefore available. High cost also prevents popularization of this technology. Nevertheless, the promising prospects of Stirling engines stimulate further research, especially for CHCP applications. Small size and quiet operation mean that they will integrate well into residential or portable applications. Some literature indicates the possibility of using a solar dish to heat the Stirling engine, thus potentially eliminating the need for combustion of a fuel [27].

- **Fuel cells**

Fuel cells are quiet, compact power generators without moving parts, which use hydrogen and oxygen to make electricity and, at the same time, can provide heat for a wide range of applications. In general, fuel cells show high electrical efficiencies under varying load and thus result in low emissions. The transportation sector is the major potential market for fuel cells [27].

	Steam Turbine	Diesel Engines	Spark Ignition engine	Combustion Turbine	Micro-turbine	Stirling engines	Fuel cells	Combined Cycle
Capacity range	50kW-20MW	5kW-20MW	3kW-6MW	250kW-50MW	15-300kW	1kW-1.5MW	5kW-2MW	50kW-500MW
Fuel used	Any	Gas, Propane, distillate oils, biogas	Gas, biogas, liquid fuels, propane	Gas, propane, distillate oils, biogas	Gas, propane, distillate oils, biogas	Any(gas, alcohol, butane, biogas)	Hydrogen and fuels containing hydrocarbons	Gas, propane, distillate oils, biogas
Efficiency Electrical (%)	7-20	35-45	25-42	25-42	15-30	≈40	37-60	35-55
Efficiency overall (%)	60-80	65-90	70-92	65-87	60-85	65-85	85-90	73-90
Power to heat Ratio	0.1-0.5	0.8-2.4	0.5-0.7	0.2-0.8	1.2-1.7	1.2-1.7	0.8-1.1	0.4-1.2
Output heat Temperature (°C)	Up to 540	-----	-----	Up to 540	200-350	60-200	260-370	Up to 350
Noise	Loud	Loud	Loud	Loud	Fair	Fair	Quite	Loud
CO ₂ Emission (kg/MW/h)	-----	650	500-620	580-680	720	672	430-490	-----
NO _x emissions (kg/MWh)	-----	10	0.2-1.0	0.3-0.5	0.1	0.23	0.005-0.01	-----
Availability (%)	90-95	95	95	96-98	98	-----	90-95	-----
Part load Performance	Poor	Good	Good	Fair	Fair	Good	Good	Fair
Life cycle (year)	25-35	20	20	20	10	10	10-20	20
Average cost Investment (\$/kW)	1000-2000	340-1000	800-1600	450-950	900-1500	1300-2000	2500-3500	400-500
Operating & maintenance costs (\$/kWh)	0.004	0.0075-0.015	0.0075-0.015	0.0045-0.0105	0.01-0.02	-----	0.007-0.05	0.004-0.009

Tab. 9.1 Characteristics and parameters of prime movers in CHCP systems

9.1 Absorption technology

Absorption chillers are one of the commercialized thermally activated technologies widely applied in existing CHCP systems; they are similar to vapor compression chillers, with a few key differences. The basic difference is that a vapor compression chiller uses a rotating device (electric motor, engine, combustion turbine or steam turbine), to raise the pressure of refrigerant vapors, while an absorption chiller uses heat to compress the refrigerant vapors to a high pressure. Therefore, this “thermal compressor” has no moving parts [27].

Absorption cooling, refrigeration and heat pumping technology is today a well proven technology. The absorption machines that are commercially available are powered by steam, by hot water or by combustion gases. Although a variety of applications may be proposed, the main market in most countries is the production of chilled water in the cooling of buildings. As economic conditions vary from country to country, absorption systems may be at the same time a small niche market in one country and the dominant technology in another country.

The basic principle of an absorption cooling machine may be illustrated with Fig. 9.4 and Fig. 9.5 In its simplest design, the absorption machine consists of an evaporator, a condenser, an absorber, a generator and a solution pump [26].

Because sites usually have a greater demand for electricity than for heat, it is the heat demand that, in most cases, determines the CHP unit’s size. As a result, most CHP units produce less electricity than the electrical base load demand of the site they serve. Where these sites also have a cooling requirement, absorption cooling offers two potential advantages: [28].

- Most of the electrical load required to meet the cooling demand is converted into a heat load, thereby reducing the electrical demand and increasing the options for heat use. This can materially alter the site’s heat to power ratio, perhaps turning a hitherto marginal case for CHP into a viable option. In some cases, it may even encourage specification of a larger CHP unit that will economically generate more electricity.
- The additional heat load allows the plant to operate more efficiently by extending profitable CHP running time and, to some extent, ‘ironing out’ the seasonal peaks and troughs. This can apply to both new and existing CHP units [28].

Most standard chiller designs require heat in the form of steam or hot water, and there is a strong link between the type of absorption chiller selected and the CHP prime mover envisaged or already in place:

Steam at 7-9 bar gauge – typically the product of a gas turbine with heat recovery boiler – is best used in a double-effect absorption chiller. This type of chiller can also accommodate hot water at 170-180°C, although these units are not widely available [28].

- Hot water or low-pressure steam is usually more appropriate to a single-effect absorption unit. The necessary level of heat is readily supplied by most models of CHP engine (hot water at 85-90°C), with larger engines producing water at temperatures of up to 130°C [28].

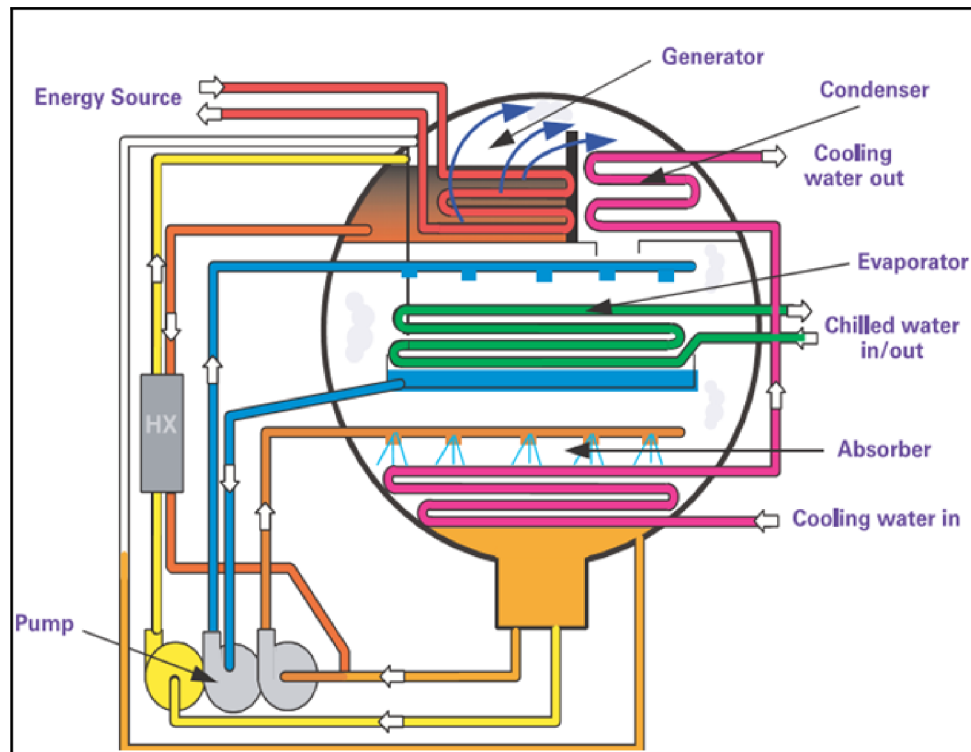

Fig. 9.4 The principal of an absorption cooling machine

In a compression cycle chiller, cold is produced in the evaporator where the refrigerant or working medium is vaporized and heat is rejected into the condenser where the refrigerant is condensed. The energy lifting heat from a low temperature to a higher temperature is supplied as mechanical energy to the compressor.

In an absorption cycle chiller, compressing the refrigerant vapor is effected by the absorber, the solution pump and the generator in combination, instead of a mechanical vapor compressor. Vapor generated in the evaporator is absorbed into a liquid absorbent in the absorber. The absorbent that has taken up refrigerant, spent or weak absorbent, is pumped to the generator where the refrigerant is released as a vapor, which vapor is to be condensed in the condenser. The regenerated or strong absorbent is then led back to the absorber to pick up refrigerant vapor anew. Heat is supplied to the generator at a comparatively high temperature and rejected from the absorber at a comparatively low level, analogously to a heat engine. The words "thermo-chemical compressor" have actually been used in specialized literature to describe the function of the generator and absorber half of the absorption cycle [26].

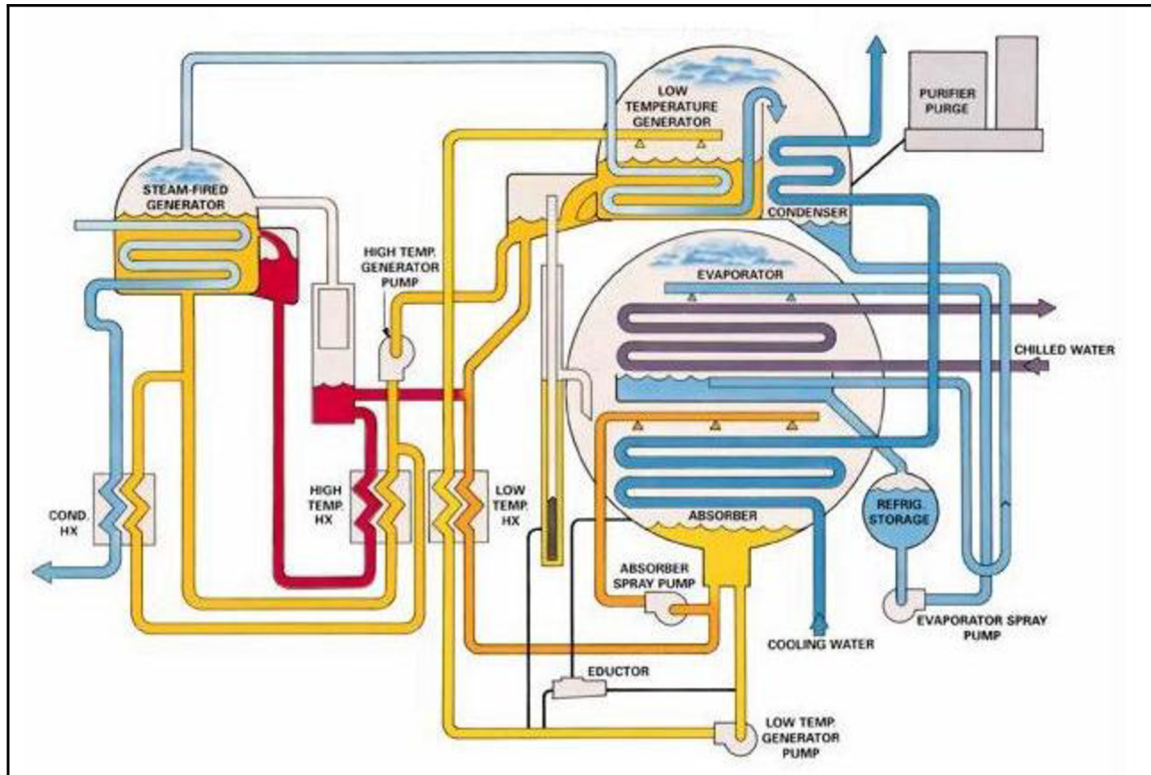

Fig. 9.5 Two stage-fired absorption machine

- **Basic Units**

Electric power is usually measured in kilowatts (kW). Electric energy is usually measured in kilowatt-hours (kWh).

Air conditioner sizes are often given as "tons" of cooling, where 1 ton of cooling equals 12,000 BTU/h (3.5 kW). 1 ton of cooling equals the amount of power that needs to be applied continuously, over a 24 hour period, to melt 1 ton of ice [65].

Performance of air condition systems, including heat pumps and chillers, describes the efficiencies of systems, which can then be used to estimate how much energy the system may use. This applies equally to residential, commercial, and industrial system.

When talking about the size of an air conditioning system (whether by tons of cooling, BTU/h, or kW), we are specifying the cooling capacity (power) of the system. The actual electrical power used to operate such a system is less. The electrical power used is one half to one third (or less) of the cooling power [40].

- **Coefficient of performance, COP**

The COP is the measurement of the amount of power input to a system compared to the amount of power output by that system.

$$COP = \frac{\text{Power output}}{\text{Power input}} \quad (9.1)$$

The COP therefore a measurement of efficiency; the higher the number, the more efficient the system is. The COP is dimensionless because the input power and output power are measured in Watts.

An air conditioning system uses power to move heat from one place to another place. When cooling, the air conditioning system is moving heat from the space being cooled (usually a room), to somewhere it is unwanted (usually outside). A heat pump uses the same principles, but it moves heat from outside (the cold side) to the space being heated inside (the living space).

The maximum theoretical COP for an air conditioning system is expressed by Carnot's theorem, reduced to the following equation:

$$COP_{\max\imum} = \frac{T_C}{T_H - T_C} \quad (9.2)$$

Where the T_C is the cold temperature and is the T_H hot temperature. For space cooling, the cold temperature is inside the space; for space heating, the cold temperature is outside. All temperature is expressed in Kelvin.

As can see from equation (9.2), as the difference between the hot temperature and the cold temperature increases, the COP becomes lower, and vice versa. This means that an air conditioning system is more efficient when the room temperature is closer to the outside temperature and will use more power when there is a larger difference in these temperatures.

Typical COP values for air conditioning and heat pump systems are in the range 2 to 4, or about a tenth of the theoretical maximum.

A heat pump takes power from the environment and uses electrical power to move that power to the inside space. More power is put into the house than used in electricity. An air conditioner operates in the same way, but it is removing power from the space, the air conditioner puts power into the environment and this power must be dissipated by the condenser [40].

- **Energy Efficiency Ratio, EER**

The EER is the ratio of output cooling energy (in BTU) to electrical input energy (in Watt-hour).

$$EER = \frac{\text{output cooling energy in BTU}}{\text{input electrical energy in Wh}} \quad (9.3)$$

The units are $BTU \cdot W^{-1} \cdot h^{-1}$.

The bizarre units of measurement originated in the US to measure the efficiency of an air conditioning system in a steady state. The units are therefore not dimensionless and EER can be measured only over time. Typically, with the system stable, one can measure the energy used over an hour period. One measures the amount of cooling the system has performed during that time.

To convert EER to COP, we need to accommodate for the units used. We convert the BTU energy and the electrical input energy to a common energy unit, namely Joules. One BTU equals 1055 J. One Wh equals 3600 Ws or 3600 J [40]. So:

$$COP = \frac{\text{output cooling energy}}{\text{input electrical energy}} = EER \text{ BTU / (Wh)} \cdot \frac{1055 \text{ J / BTU}}{3600 \text{ J / (Wh)}} = EER \cdot 0.293 \quad (9.4)$$

Alternatively:

$$EER = COP \cdot 3.41 \quad (9.5)$$

- **Seasonal Energy efficiency Ratio, SEER**

As with EER, the SEER is the ratio of output cooling energy (in BTU) to electrical input energy (in Watt-hour). However, the SEER is a representative measurement of how the system behaves over a season where the outdoor temperature varies:

$$SEER = \frac{\text{output cooling energy in BTU over a season}}{\text{input electrical energy in Wh during the same season}} \quad (9.6)$$

The US department of energy (DOE) defined the formula to be used to calculate SEER values for residential air conditioning systems of less than 65,000 BTU/h (19 kW). The manufacturer makes EER or COP measurements at various values for in-door and outdoor temperature and then computes the SEER. The result is one number that may guide a prospective purchaser or owner of a system to compare one unit with another unit [40].

- **Heating Seasonal Performance factor (HSPF)**

This is a measurement of the efficiency of a system and the units are BTU/h divided by Watts. However, this measures the efficiency of the system in heating mode, not cooling mode. Therefore it applies only to heat pumps or reversible air conditioning units and not to units that only cool a space. A variant of equation (9.3) applies:

$$COP = \frac{\text{Output heating energy}}{\text{input electrical energy}} = HSPF \cdot 0.293 \quad (9.7)$$

As with COP, EER, SEER, the higher the number of HSPF, the greater the efficiency

- **Kilo-Watt per Ton (kW/ton)**

The efficiencies of large industrial air conditioner systems, especially chillers, are given in kW/ton to specify the amount of electrical power that is required for a certain power of cooling. A smaller value represents a more efficient system. However, as we have seen, to be valid, this number must be reported at various operating conditions, especially the indoor and outdoor temperatures, and the difference between chilled water return and chilled water supply.

kW/ton to COP can be converted as follows:

$$COP = \frac{\text{Power output in W}}{\text{Power input W}} = \frac{3,517}{\text{kW / ton}} \quad (9.8)$$

One ton of refrigeration is equivalent to 3.517 kW.

9.2 Example for compression chillier and absorption chillier

Although cooling can be provided by conventional vapor compression chillers driven by electricity, low quality heat (low temperature, low pressure) expelled from the cogeneration plant can drive the absorption chillers so that the overall primary energy consumption is reduced. Absorption chillers have recently gained widespread acceptance due to their capability of not only integrating with cogeneration system but also because they can operate with industrial waste heat streams. The benefit of power generation and absorption cooling can be realized through the following example that compares it with a power generation system with a conventional vapor compression system [39].

A factory requires 1 MW of electricity and 500 refrigeration tons (RT). The gas turbine generates electricity required for the on-site energy processes as well as the conventional vapor compression chiller.

Assuming an electricity demand of 0.65 kW/RT, the compression chiller needs 325 kW of electricity to obtain 500 RT of cooling. Therefore, a total of 1325 kW of electricity must be provided to this factory. If the gas turbine efficiency has an efficiency of 30 percent, primary energy consumption would be 4417 kW, see Fig. 9.6 [39].

$$\eta_t = \frac{\text{Output}}{\text{Input}} \Rightarrow \text{Input} = \frac{\text{Output}}{\eta_t} = kW$$

$$\text{Input} = \frac{1325}{0.30} = 4417kW$$

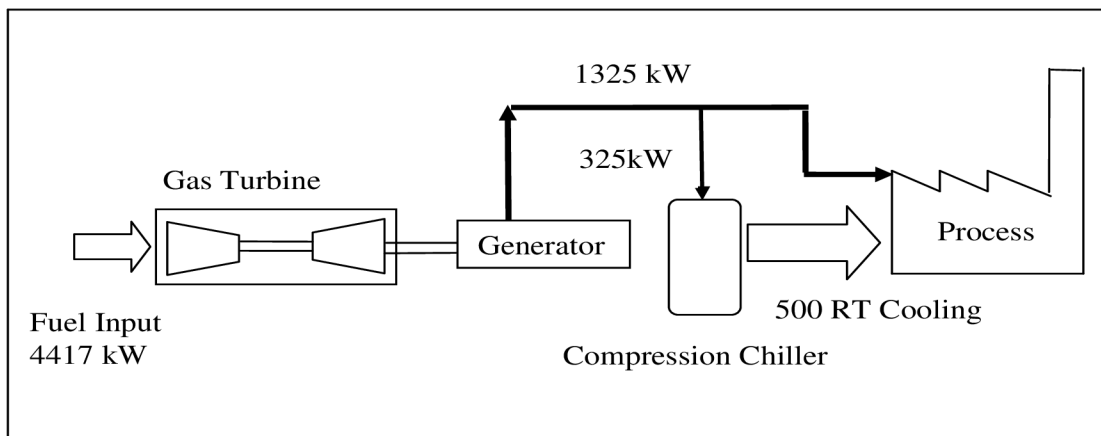

Fig. 9.6 Schematic diagram of power generation and cooling with electricity [39]

However, a cogeneration system with an absorption chiller (thereby making this a "tri-generation" plant) can provide the same energy service (power and cooling) by consuming only 3333 kW of primary energy versus 4417 kW, thereby saving nearly 25% in primary energy usage, see Fig. 9.7.

$$\text{Input} = \frac{1000}{0.30} = 3333kW$$

The ratio between the systems = $\frac{3333}{4417} = 0.754$

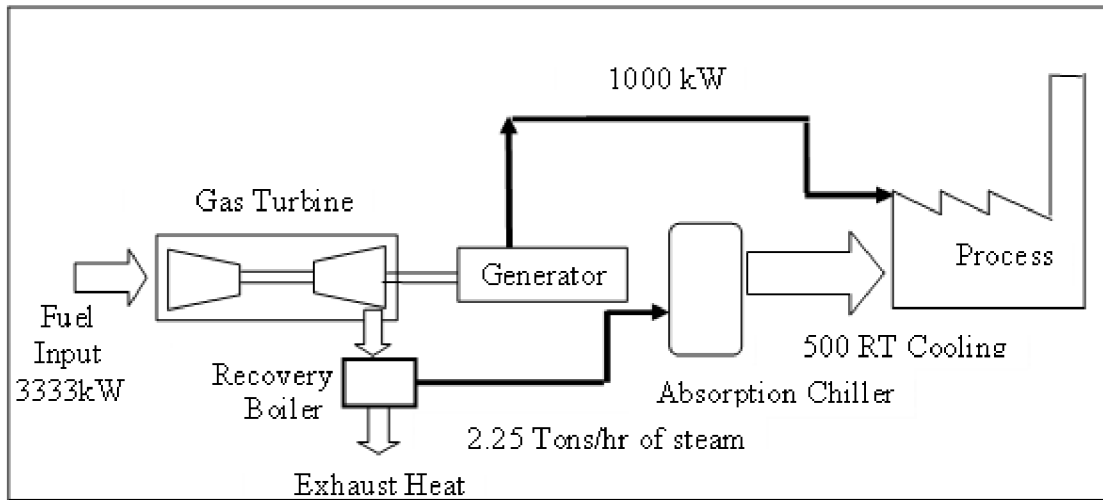

Fig. 9.7 Schematic diagram of power generation and absorption cooling [39]

This example clearly points out the advantages of tri-generation over typical cogeneration plants. A tri-generation plant (with an absorption chiller) can save about 24.5 percent of primary energy in comparison with a cogeneration plant and vapor compression chiller

Note: A refrigeration ton (RT) is defined as the transfer of heat at the rate of 3.52 kW, which is roughly the rate of cooling obtained by melting ice at the rate of one ton per day [39].

Tab. 9.2 Comparison between compression and absorption chillers

Vapor Compression Characteristics	Vapor Absorption Characteristics
Efficient operation	Poor efficiency
Consume Electrical Energy	Consume Steam Energy
Typically noisy	Quiet operation
AC operation	AC/DC power
Higher operation cost	Low operation cost
Low capital cost	High capital cost

9.3 Comparison of utilization of traditional energy supply mode and typical CHCP system

A theoretical calculation of prime energy utilization based on traditional energy supply mode and typical CHCP system can be seen in Fig. 9.8 and Fig. 9.9. If an end user needs 33 units of electrical power, 40 units of cooling power and 15 units of heating power on a summer day, 148 units of prime energy are consumed in the traditional way. A centralized power plant runs at the efficiency of 33% and 100 units of prime energy are used to generate 33 units of electrical power. A traditional boiler burns 18 units fuel to heat 15 units of domestic hot water at the efficiency of

85%. Electrical air-conditioner driven by 10 units of electrical power can generate 40 units of cooling power at a COP of 4. However, consider the efficiency of electricity generation in a power plant, 30 units of prime energy is needed in all for space cooling. Based on a typical CHCP system shown in Fig 9.9, only 100 units of prime energy are needed for 33 units of electrical power, 40 units of cooling power and 15 units of heating power on a summer day. The electricity generation efficiency of a CHCP system is similar to a centralized power plant, because electricity is consumed locally without loss on distribution lines, though its small-scale prime mover is less efficient than the large prime mover in the power plant. The keystone of full energy utilization of CHCP system lies in the recovery of waste heat from prime mover [27].

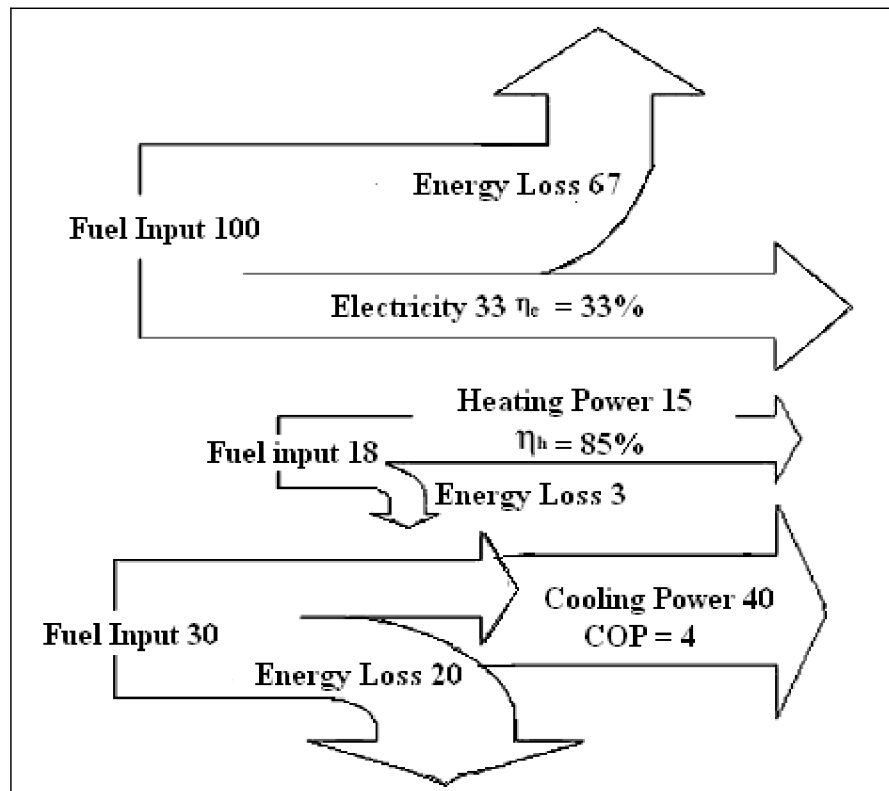

Fig. 9.8 Energy flow of traditional supply mode [27]

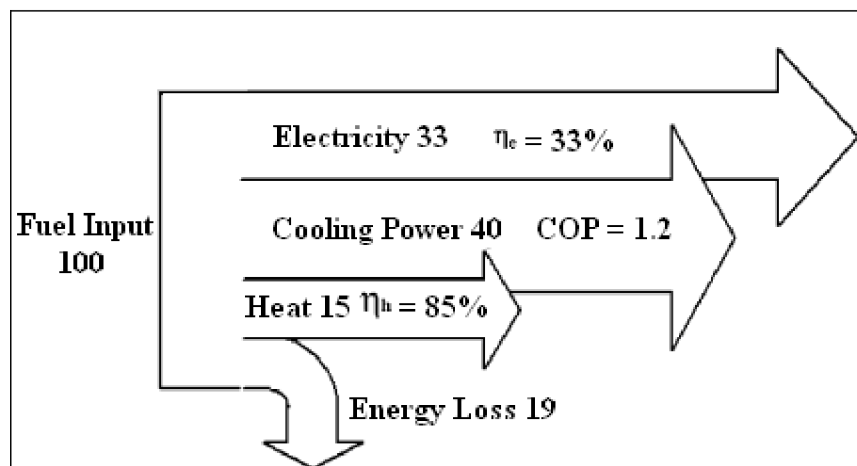

Fig. 9.9 Energy flow of typical CHCP system [27]

Thirty four units of waste heat in the form of exhaust gas and machine coolant are used to drive an absorption chiller at a COP of 1.2, thus 40 units of cooling power can be obtained. And another 18 units of waste heat can be recovered to heat 15 units of domestic water at an efficiency of 85% similar to the efficiency of a boiler. Compared with traditional energy supply mode, CHCP systems can save 48 units of prime energy to meet the same demand of cooling, heating and power.

The second benefit of distributed CHCP systems is emission reduction; viewed from two aspects and sorted by different prime movers. Some prime movers with new technologies, like fuel cells and micro-turbines expel much fewer emissions (including NO_x, CO₂), than do traditional technologies from centralized power plants. Other prime movers, equipped in CHCP systems with smaller capacity than their larger counterparts in centralized power plants, emit somewhat more NO_x and CO₂ per kW electricity generated. Nevertheless, the promotion of energy efficiency CHCP systems should be encouraged at this time: burning significantly less fuel to meet the same demand results insignificant emission reduction, which surely overrides the additional emissions caused by the slight decrease in converting efficiency in small-scale prime movers.

Last, but of equal importance, CHCP systems increase the reliability of the energy supply network [27].

10 DISTRIBUTION NETWORK

10.1 Heating distribution network

Heating system components may be grouped into three functional categories: source components, distribution components, and delivery components. Source components provide heat energy. Distribution components convey a heating medium from a source location to portions of a building that require heating or conditioning. Delivery components serve as an interface between the distribution system and occupied spaces [30].

District Heating (DH), refers to a method of supplying heat to buildings, factories, and other facilities from a central source. The basic structure of District Heating Systems is shown in Fig. 10.1. The DH System consists of one or more heat generating facilities, a widely spread heat distribution network, and substations between the distribution network and the consumer. Heat is generated by the heat sources and transferred to an appropriate heating medium such as hot water or steam. The heating medium is transported via pipelines to a substation. In the substation heat is transferred to the individual heating systems of the end-users.

Space heating, space cooling, and domestic hot water supply represents the largest part of energy consumption (75%) in buildings and industries. This demand is met mainly by fossil fuels and electrical energy. At the same time a vast amount of waste heat is discharged into the atmosphere by power and waste incineration plants and other industrial processes. The efficiency of current power plants does not exceed 50%.

District heating brings the waste heat directly to the customers as a salable product. This makes individual furnaces redundant. Additional advantages result from higher efficiency of central heat generation, lower emissions, and the capability of fuel diversification by using the fuel with the lowest price and the best availability. A central energy supply, based on combined heat and power generation has an overall efficiency of up to 80% [31].

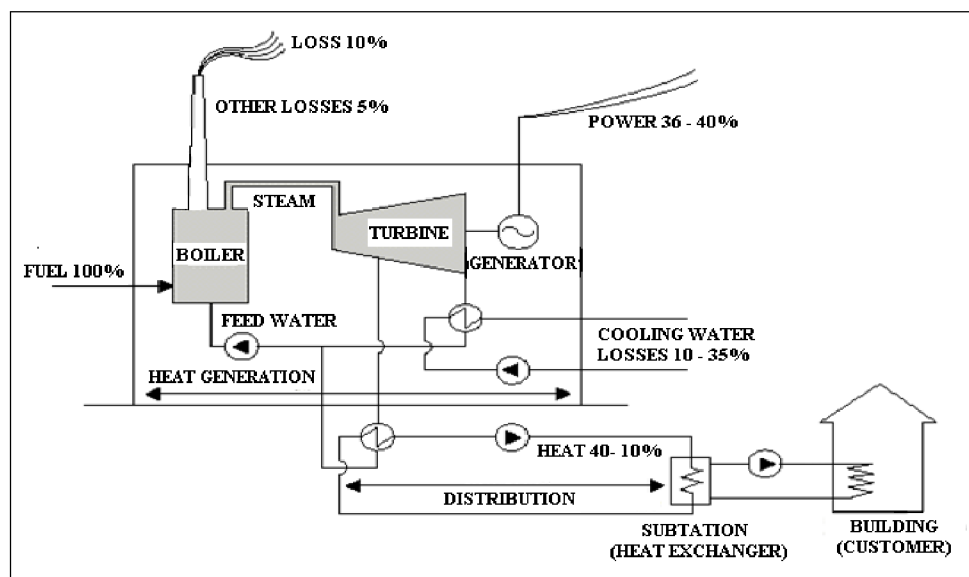

Fig. 10.1 District heating network [31]

10.1.1 Pipelines

Pipelines transfer heat from where it is generated to the consumer. Depending on the heat source, the distribution network generally consists of pairs of supply and return pipes. Hot water flows continuously through the supply pipes to the substations, heats the secondary fluid in heat exchangers, and returns to the heat source through the return flow pipes. The distribution network facilities also include booster pumps and pressure reducing stations, mixing (temperature reducing) stations, key-points with valves to turn on or shut off branch lines and a large number of measuring points distributed over the entire network, see Fig. 10.2 and Fig. 10.3 [31].

Central systems produce a heating and/or cooling effect in a single location. This effect must then be transmitted to the various spaces in a building that require conditioning. Three transmission media are commonly used in central systems: air, water, and steam. Hot air can be used as a heating medium, cold air as a cooling medium. Hot water and steam can be used as heating media, while cold water is a common cooling medium. A central system will always require distribution components to convey the heating or cooling effect from the source to the conditioned locations [30].



Fig. 10.2 Typical piping installations [32]

The transfer medium is generally hot water at temperatures up to 400F (204°C) and pressures up to 2 MPa. The optimum operating conditions, temperature and pressure, depend on the structure and dimensions of the network and the heat source. The water temperature is generally limited to 265F (129°C) on the supply side. In fact, many networks now keep the supply temperature under 180F (82°C), allowing use of lower cost equipment and fewer safety devices. Outdoor Air Temperature Control reduces the supply temperature in a network with increasing outdoor temperature. The return water temperature in a DH network is controlled to not exceed either a fixed or variable temperature level [31].

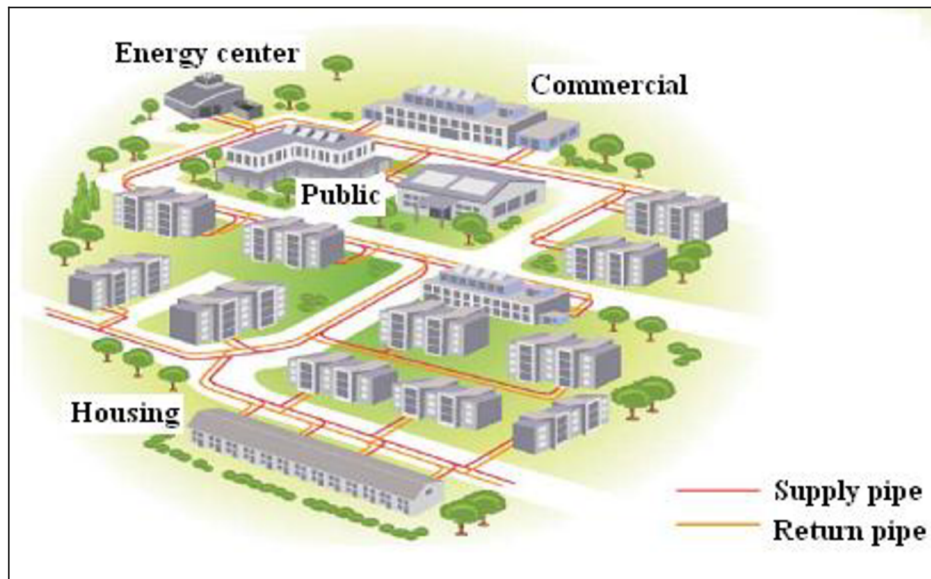

Fig. 10.3 Distribution Network

10.1.2 The Substation (Heat exchanger)

Substations (Heat exchanger) transfer the required heat from the distribution network to individual building heating networks (customer). In some cases, a large heat exchanger station (HES) is required between different types of networks. The HES transfers heat from high power primary networks to smaller secondary networks with lower temperatures and pressures.

A DH system only works efficiently if all components are matched to one another. The heat source must deliver the required heat at the lowest cost level, 365 days a year. Heat demand is a function of the day of the week [31].

- **Thermal energy storage**

Thermal energy storage (TES) is a technology that stocks thermal energy by heating or cooling a storage medium so that the stored energy can be used at a later time for heating and cooling applications and power generation. TES systems are used particularly in buildings and industrial processes. In these applications, approximately half of the energy consumed is in the form of thermal energy, the demand for which may vary during any given day and from one day to next.

Therefore, TES systems can help balance energy demand and supply on a daily, weekly and even seasonal basis. They can also reduce peak demand, energy consumption, CO₂ emissions and costs, while increasing overall efficiency of energy systems.

There are three kinds of TES systems, namely:

- 1- Sensible heat storage that is based on storing thermal energy by heating or cooling a liquid or solid storage medium (e.g. water, sand, molten salts, rocks), with water being the cheapest option.
- 2- Latent heat storage using phase change materials or PCMs (e.g. from a solid state into a liquid state).

- 3- thermo-chemical storage (TCS) using chemical reactions to store and release thermal energy [33].

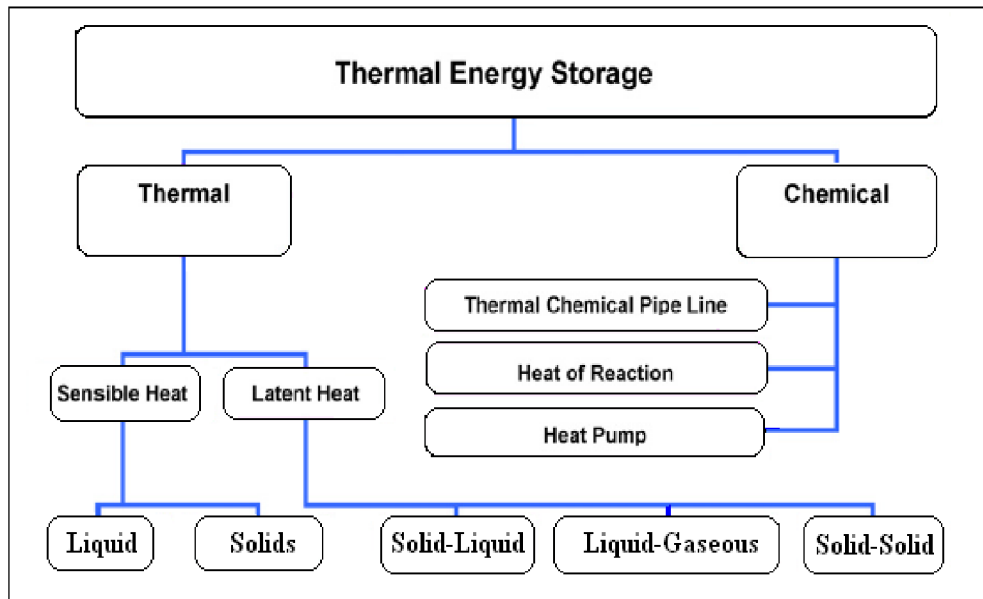

Fig. 10.4 Different types of thermal energy storage [34]

Sensible heat storage is relatively inexpensive compared to PCM and TCS systems and is applicable to domestic systems, district heating and industrial needs. However, in general sensible heat storage requires large volumes because of its low energy density (i.e. three and five times lower than that of PCM and TCS systems, respectively).

Thermal energy storage systems can be either centralized or distributed systems. Centralized applications can be used in district heating or cooling systems, large industrial plants, combined heat and power plants, or in renewable power plants (e.g. CSP plants). Distributed systems are mostly applied in domestic or commercial buildings to use energy for water and space heating or cooling.

Thermal energy (i.e. heat and cold) can be stored as sensible heat in heat storage media, as latent heat associated with phase change materials (PCMs) or as thermo-chemical energy associated with chemical reactions (i.e. thermo-chemical storage) at operation temperatures ranging from -40°C to above 400°C . Typical figures for TES systems are shown in Tab. 10.1, including capacity, power, efficiency, storage period and costs [31].

Thermal energy storage in the form of sensible heat is based on the specific heat of a storage medium, which is usually kept in storage tanks with high thermal insulation. The most popular and commercial heat storage medium is water, which has a number of residential and industrial applications. Underground storage of sensible heat in both liquid and solid media is also used for typically large-scale applications. However, TES systems based on sensible heat storage offer a storage capacity that is limited by the specific heat of the storage medium. Phase change materials (PCMs) can offer a higher storage capacity that is associated with the latent heat of the phase change. PCMs also enable a target-oriented discharging temperature that is set by the constant temperature of the phase change. Thermo-chemical storage (TCS) can offer even higher storage capacities. Thermo-chemical reactions (e.g. adsorption or the adhesion of a substance to

the surface of another solid or liquid) can be used to accumulate and discharge heat and cold on demand (also regulating humidity) in a variety of applications using different chemical reactants. At present, TES systems based on sensible heat are commercially available, while TCS and PCM-based storage systems are mostly under development and demonstration.

The storage of thermal energy (typically from renewable energy sources, waste heat or surplus energy production) can replace heat and cold production from fossil fuels, reduce CO₂ emissions and lower the need for costly peak power and heat production capacity. In Europe, it has been estimated that around 1.4 million GWh per year could be saved and 400 million tones of CO₂ emissions avoided, in the building and industrial sectors by more extensive use of heat and cold storage.

The use of hot water tanks is a well known technology for thermal energy storage. Hot water tanks serve the purpose of energy saving in water heating systems based on cogeneration (i.e. heat and power) energy supply systems. State-of the art projects have shown that water tank storage is a cost-effective storage option and that its efficiency can be further improved by ensuring an optimal water stratification in the tank and highly effective thermal insulation.

Hot water storage systems used as buffer storage for domestic hot water (DHW) supply are usually in the range of 500 liter to several m³. This technology is also used in solar thermal installations for DHW combined with building heating systems (Solar-Combi-Systems). Large hot water tanks are used for seasonal storage of solar thermal heat in combination with small district heating systems. These systems can have a volume of up to several thousand cubic meters (m³) (see Fig. 10.5). Charging temperatures are in the range of 80-90°C. The usable temperature difference can be enhanced by the use of heat pumps for discharging (down to temperatures around 10 °C).

Underground thermal energy storage (UTES) is also a widely used storage technology, which makes use of the underground as a storage medium for both heat and cold storage. UTES technologies include borehole Thermal Energy Storage, aquifer storage, cavern storage and pit storage. Which of these technologies is selected strongly depends on the local geological conditions [34].



Fig. 10.5 Large Hot water storage (construction and final state) [33]

Tab. 10.1 Typical parameters of thermal energy storage systems [33]

TES System	Capacity [kWh/t]	Power [MW]	Efficiency [%]	Storage Period [h, d, m]	Cost [€/kWh]
Sensible (Hot water)	10-50	0.001-10	50-90	d/m	0.1-10
PCM	50-150	0.001-1	75-90	h/m	10-50
Chemical reactions	120-250	0.01-1	75-100	h/d	8-100

10.2 Electrical distribution network

The electrical power system consists of three major components: generation, a high voltage transmission grid, and distribution system, as shows in Fig. 10.6

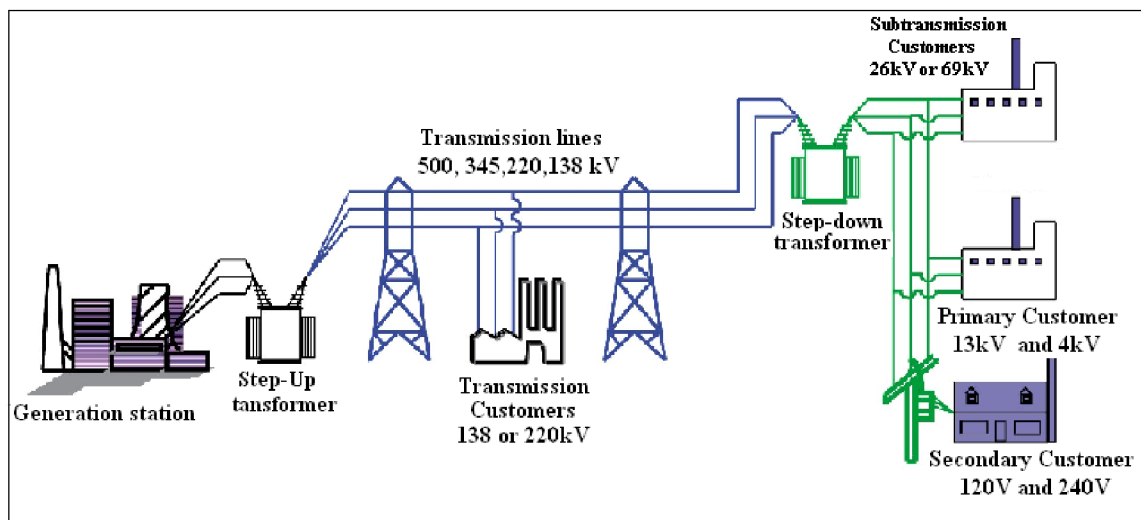
**Fig. 10.6 Electric distribution networks [5]**

Electric-power transmission is the bulk transfer of electrical energy, from generating power plants to electrical substations located near demand centers. This is distinct from the local wiring between high-voltage substations and customers, which is typically referred to as electric power distribution. Transmission lines, when interconnected with each other, become transmission networks. The combined transmission and distribution network is known as the "power grid". Most transmission lines use high-voltage three-phase alternating current (AC); High-voltage direct-current (HVDC) technology is used for greater efficiency over very long distances (typically hundreds of kilometers). Electricity is transmitted at high voltages (110 kV or above) to reduce the energy lost in long-distance transmission.

Underground power transmission has a significantly higher cost and greater operational limitations but is sometimes used in urban areas or sensitive locations. There is very little ability to store electricity, therefore must be generated as needed. A sophisticated control system is required to ensure electric generation very closely matches the demand. Transmission-level voltages are usually considered to be 110, 220, 400 kV and above. Lower voltages such as 66 kV and 35 kV are usually considered sub-transmission voltages but are occasionally used on long lines with light loads. Voltages less than 35 kV are usually used for distribution [35].

Step-down transformer

At the substations, transformers reduce the voltage to a lower level for distribution to commercial and residential users. This distribution is accomplished with a combination of sub-transmission (35 kV to 110 kV) and distribution (35, 22, 11, 6 kV). Finally, at the point of use, the energy is transformed to low voltage (varying by country and customer requirement).

Losses

Power generated in power stations passes through large and complex networks like transformers, overhead lines, cables and other equipment to reach the end users. It is a fact that the units of electric energy generated by the power station does not match the units distributed to the consumers. Some percentage of the units is lost in the distribution network. This difference in the generated and distributed units is known as transmission and distribution loss [36], (up to 8% occur in the electric power transmission and distribution network in the form of electric current losses and power transmission losses (step-up and step-down transformer losses)

$$Loss_{T+D} = \frac{E_{in} - E_b}{E_{in}} \cdot 100 \quad (10.1)$$

Where :

E_{in} : Input energy to feeder (kWh)

E_b : Billed Energy to Consumer (kWh)

Loss_{T+D} : Energy losses by transmission and distribution (%)

Power losses can be divided into two types of losses. It is common to use two categories:

1. Technical losses

Technical losses are losses that occur in electrical equipment, especially cables, over-head lines and power transformers [36].

Basic losses equation

$$E_{Loss} = 3 \cdot I_m^2 \cdot R \cdot L \cdot H \cdot T \cdot 10^{-3} \quad (kWh) \quad (10.2)$$

E_{Loss} Line Conductor's electric energy (kWh)

I_m Maximum line current (A)

R Conductor resistance per phase (/km)

L Line length (km)

H Loss factor, $H = \frac{(\text{Average current})^2}{(\text{Maximum current})^2} \times 100$

T Calculation period (8760h/y)

2. Non Technical Losses (Commercial Losses)

Commercial losses can be determined for each single consumer as difference between delivered electricity to the end-user and registered energy by energy-meters. It is very simply when an energy-meter doesn't work properly, and related to meter reading, defective meters, billing of customer energy consumption, and the estimation of unmetered supply of energy as well as energy thefts [37].

11 ELECTRICAL CONSUMPTION OF TYPICAL FAMILY HOUSES

11.1 Consumption in the domestic sector

This analytical field study was of the pattern of energy consumption in the domestic sector, where the study included an appropriate number of consumers at the main largest three cities of Libya.

The aim of the study was to identify the pattern of consumption in one of the main consuming sectors of energy in the country, the residential sector, and to determine the nature of consumption of household appliances. In addition it sought the possibility of finding a solution or a suitable alternative such as other uses of current wasted energy, increased energy efficiency and a reduction of peak loads.

The methodology of field studies in the preparation of a questionnaire enables researchers interested in studying the consumption of the household sector to obtain the information needed to study the behavior of consumption in the domestic sector. This is done by an inventory of the basic household appliances, as well the number of hours of their operation and the electrical power used to calculate the annual consumption.

The preparation of a detailed questionnaire about household electrical equipment was distributed to a variety of samples, including 650 houses, in Tripoli, Benghazi, and Sabha. The number of the questionnaires collected was 402, thus the response rate was 62%, Tab. 11.1 shows the number of questionnaires distributed and collected [38].

Tab. 11.1 Number of questionnaires distributed by regions

Region	Number of questionnaires distributed	Number of questionnaires collected	The response rate [%]
Tripoli	250	220	88
Benghazi	200	100	50
Sabha	200	82	41
Total	650	402	62

According to international studies in such a field, the response to this kind of field study ranges from 30-40% of total distributed questionnaires, thus the obtained results were good, exceeding the upper limit of 40 %.

The database designed using the Excel program contains all the paragraphs of questions to complete the questionnaire and compute the annual consumption, taking into account:

- The actual time for operation of refrigerators is 60% of continuous operating time.
- The actual time for operation of freezers is 50% of continuous operating time.
- The actual time for operation the water heaters is 33% of continuous operating time for half of the year (the months which have need of hot water)

The annual consumption for each consumer in the sample was calculated, which is the total electrical consumption by appliances and equipment which the family owned, where a maximum consumption amounted to 39307 kWh/year, while minimum consumption was as low as to 984 kWh/year.

Consumers were divided into three segments, namely small consumers, which range between 0 to 5000 kW hours per year; and medium consumers with a range from 5001 to 10000 kW hours per year; and finally large consumers of 10001 and above. A family's ownership of electrical equipments depends primarily on family income.

The study included the following equipment: cooking equipment, refrigerators, freezers, radios, videos, computers, light bulbs of all kinds, washing machines, water pumps, air conditioners, fans, heaters, and finally water heaters.

Percentage of ownership means the percentage of consumers who own a certain type of equipment for all size of the sample (402 consumers) [38].

Tab. 11.2 Distribution of electrical devices on consumers

Devices	Percentage of ownership [%]	Average daily operating hours	Average power [W]	Average annual consumption [kWh]
Cooking	5.22	0.3	1283	150
Refrigerator-1	96.5	14.4	146	769
Refrigerator-2	17.4	16.0	149	867
Freezer-1	40.3	12.0	147	642
Freezer-2	3.98	10.7	157	615
W machine	73.1	0.9	251	85
TV-1	98.8	8.0	85	249
TV-2	39.6	6.7	82	200
TV-3	8.21	6.5	87	207
Computer	3.23	3.0	207	229
Radio-1	60.2	4.2	25	39
Radio-2	7.21	3.0	25	27
Radio-3	0.75	2.0	25	18
Bulb-100W	70.4	4.9	100	1802
Bulb-60W	28.6	2.5	60	449
Bulb-40W	10.7	3.7	40	783
Florescent	20.9	3.2	44	225
Ironing	68.4	0.8	1009	296
Water Pump-1	43.8	2.0	965	693
Water pump-2	1.74	0.9	745	254
ACs -1unit	12.2	6.4	1901	4425
ACs -2 units	3.23	9.4	1633	5582
ACs -3 units	1	2.0	2675	1953
ACs -4 units	0.5	3.8	2675	3661
ACs -5 units	0.25	4.8	1400	2427
WAC-1 unit	20.9	6.5	1690	3995
WAC-2 units	6.47	4.5	1876	3108
WAC-3 units	1.99	1.5	1400	767

WAC-4 units	0.5	1.5	1400	767
WAC-5 units	0.25	0.8	1400	387
Fan-1 unit	46	5.3	99	96
Fan-2 units	8.71	4.5	94	78
Heat-1 unit	35.8	6.1	1229	684
Heat -2 units	5.22	5.2	1367	646
Heat-3 units	1	8.0	500	365
Water heater-1	90.3	7.9	1203	1739
Water heater-2	20.4	7.9	1226	1772
Water heater-3	5.72	7.9	1227	1774
Water heater-4	1.49	7.9	1200	1734
Water heater-5	0.25	7.9	1200	1734

ACs: split air condition unit, WAC: Window air condition unit, W Machine: Washing machine

As Tab. 11.2 indicates, there are some who have ownership of more than one device of the same type. For example, there are those who have five water heaters, while at same time there are some of them do not have a water heater in the house at all, as is evidenced by the fact that the percentage of ownership of one water heater was 90.3%. Thus, for example, 9.7% of the total study sample do not have water heaters.

Tab. 11.3 contains total annual energy consumed, depending on the purpose of use in descending order, which is the result of multiplying the proportion of ownership by the annual average consumption multiplied by total the number of consumers (402 consumers).

$$\text{Percentage of ownership} \cdot \text{Average annual consumption} \cdot \text{Total number of consumers} \quad (11.1)$$

Tab. 11.3 Total annually consumed energy depending of purpose of the usage

Purpose of use	Energy consumed [kWh]	Percent [%]	Average of energy consumption [kWh]
Water heater	817339	25.92	2033
Air conditioning	731352	23.19	1819
Lighting	614123	19.47	1527
Refrigerators	472961	15.00	1176
TV	137255	4.35	341
Water Pump	123679	3.92	307
Heater	113583	3.60	282
Ironing	81417	2.58	202
Washing machine	24977	0.79	62
Fans	20478	0.65	50
Radio	10387	0.33	25
Cooking	3157	0.10	7
Computers	2983	0.09	7
Total	3153691	100	
Average of consumption	7845		

Tab. 11.3 shows that maximum consumption of energy was for water heating. This is obvious because the majority of consumers have water heaters, in addition to high electrical power for these devices. Air conditioners come in second in terms of consumption; these devices are considered high consumption of electric power. Tab. 11.4 shows maximum and minimum and average annual consumption for the three cities.

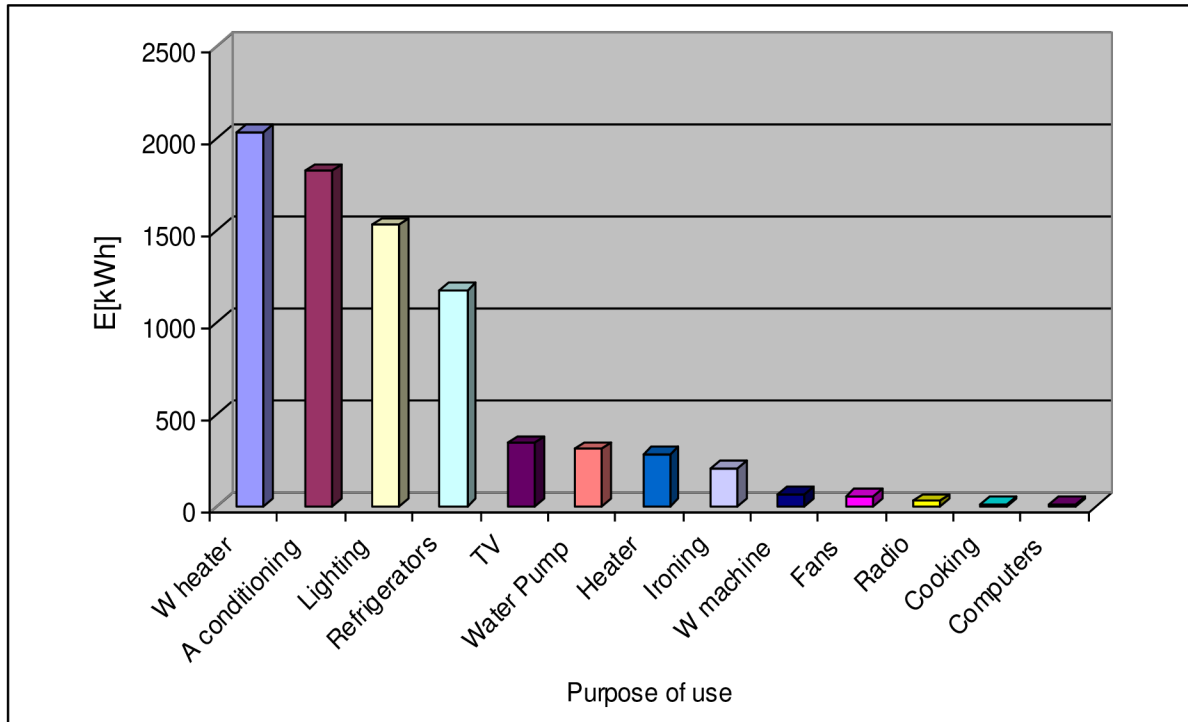

Fig. 11.1 Annually energy consumed depending on purpose of use of average consumer

Tab. 11.4 Maximum and minimum and average annual consumption [kWh]

	Tripoli	Benghazi	Sabha
Maximum Consumption	39307	24802	29649
Minimum Consumption	984	1765	2371
Average Consumption	6899	6647	10697

Temperatures vary in Libya, according to the seasons of the year in summer and winter, and there is a clear difference between the coastal and southern regions. Tab. 11.5 shows the highest and lowest temperatures recorded in Libya in some years.

Tab. 11.5 Maximum and minimum and average temperature in Libya

year	Jan		Feb		Mar		Apr		May		Jun	
	Max	Min	Max	Min	Max	Min	Max	Min	Max	Min	Max	Min
2000	22.8	0.4	23.5	1.7	36.0	3.2	41.1	7.3	42.1	10.3	41.7	14.0
2007	25.8	0.8	29.0	0.9	34.6	2.9	40.0	5.7	42.7	9.5	43.9	12.9
Average	25.4	0.6	29.2	0.8	35.6	3.0	39.7	6.0	42.5	9.6	43.2	12.5
year	Jul		Aug		Sep		Oct		Nov		Dec	
	Max	Min	Max	Min	Max	Min	Max	Min	Max	Min	Max	Min
2000	45.2	13.9	41.8	15.6	44.9	14.2	39.1	9.4	34.0	5.3	26.9	2.7
2007	44.6	15.6	43.9	16.7	43.1	14.9	39.0	10.7	33.6	5.1	27.4	1.6
Average	44.6	15.5	43.9	16.7	43.0	14.8	38.6	11.0	33.8	5.6	27.2	1.7

11.1.1 Consumers in Tripoli

The sample in this region included 220-consumers, 112 of them were small, 69 of them were medium, and 39 were large consumers. Tab. 11.6 and Fig. 11.2 show the ratios of annual electrical energy consumption depending on the purpose of use. From this table, it can clearly be seen that highest rates of consumption are for water heating (39.27%) for small consumers, then lighting and cooling. It is the same order for medium consumers with a note of declining consumption of energy for heating water. For large consumers the highest rate of consumption was clearly for air conditioning (35.24%), followed by water heating rate [38].

Tab. 11.6 Proportion of annual electrical energy consumption depending on the purpose of use of Tripoli City

The purpose of use	Power in percentage (%) & kWh of total consumption for each category					
	Small consumptions		Medium consumptions		Large consumptions	
	[%]	[kWh]	[%]	[kWh]	[%]	[kWh]
Water Heaters	39.27	1396	28.55	2000	21.04	3379
Air conditioning	0.00	0	8.23	576	35.24	5660
Lighting	26.12	928	23.60	1653	17.27	2774
Cooling	20.88	742	18.55	1299	11	1767
TV	6.74	239	5.47	383	3.07	493
Water pump	1.82	64	5.11	358	5.08	816
Heaters	0.41	14	4.15	290	3.45	554
Ironing	2.76	94	3.86	270	2.31	371
Washing Machine	0.71	25	1.09	76	0.53	85
Fans	0.67	23	0.91	63	0.32	51
Radio	0.55	19	0.36	25	0.25	40
Cooking	0.00	0	0.04	2	0.23	36
Computer	0.05	1	0.07	4	0.20	32
Average consumption [kWh]	3556		7006		16064	
Total consumption [kWh]	398231		483396		626480	

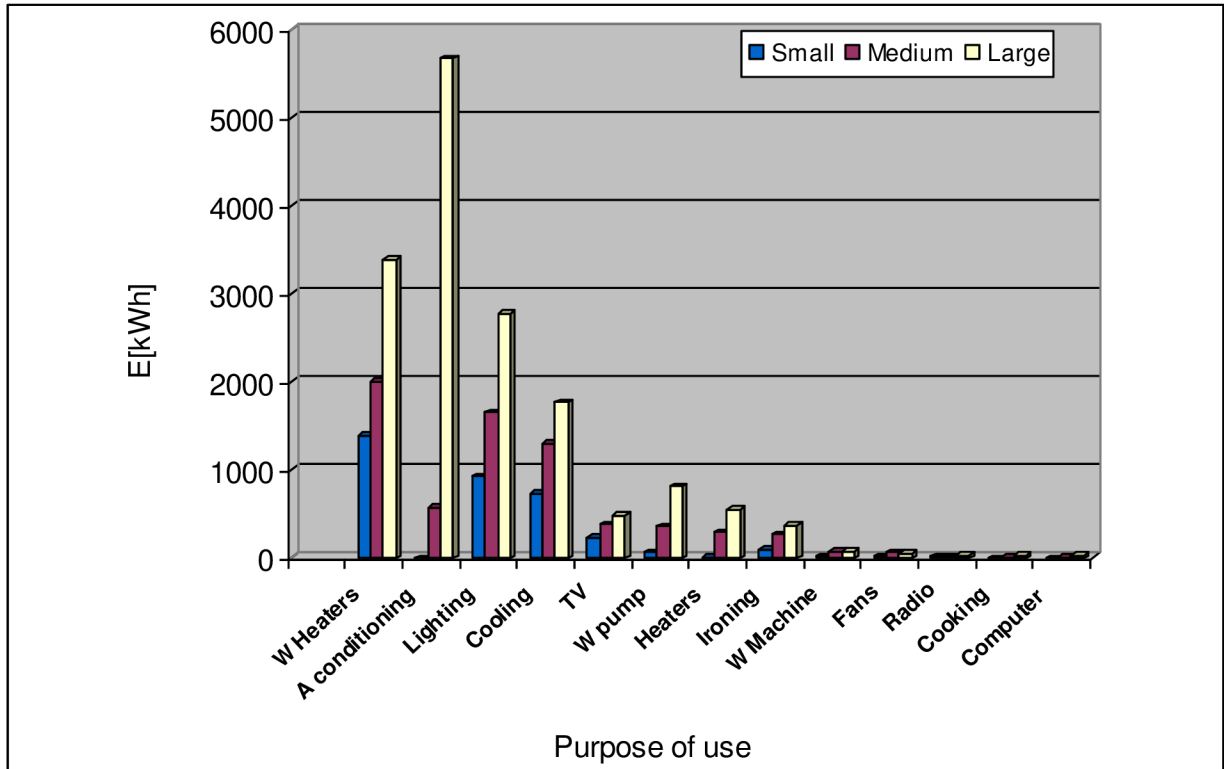

Fig. 11.2 Annual electrical energy consumption, depending of purpose of use, Tripoli

11.1.2 Consumers in Benghazi

The sample in this region included 100 consumers, 43 of them were small, 42 of them were medium, and 15 were large consumers. Tab. 11.7 and Fig. 11.3 show the ratios of annual electrical energy consumption depending on the purpose of use. Clearly the highest rates of consumption are for water heating (36.27%) for small consumers, then lighting and cooling, and consumption was in the same order for the medium consumers. For large consumers the highest rate of consumption was for water heating too (29.04%), then followed by air conditioning.

Tab. 11.7 Proportion of annual electrical energy consumption depending on the purpose of use of Benghazi City

The purpose of use	Power percentage (%) & kWh of total consumption for each category					
	Small consumptions		Medium consumptions		Large consumptions	
	[%]	[kWh]	[%]	[kWh]	[%]	[kWh]
Water Heaters	36.27	1364	31.96	2150	29.04	4201
Air conditioning	0.00	0	1.49	100	24.95	3610
Lighting	27.68	1041	25.29	1701	16.10	2329
Cooling	22.44	844	17.57	1182	12.95	1873
TV	6.85	257	6.16	414	3.68	532
Water pump	1.12	42	3.59	241	1.50	217
Heaters	2.14	80	7.64	514	9.30	1345
Ironing	1.43	53	3.29	221	1.52	219
Washing Machine	0.89	33	0.95	63	0.40	57

Fans	0.64	24	0.87	58	0.23	92
Radio	0.27	10	0.31	20	0.14	20
Cooking	0.26	9	0.39	24	0.19	27
Computer	0.00	0	0.48	32	0.00	0
Average consumption [kWh]	3762		6729		14469	
Total consumption [kWh]	161744		282631		217039	

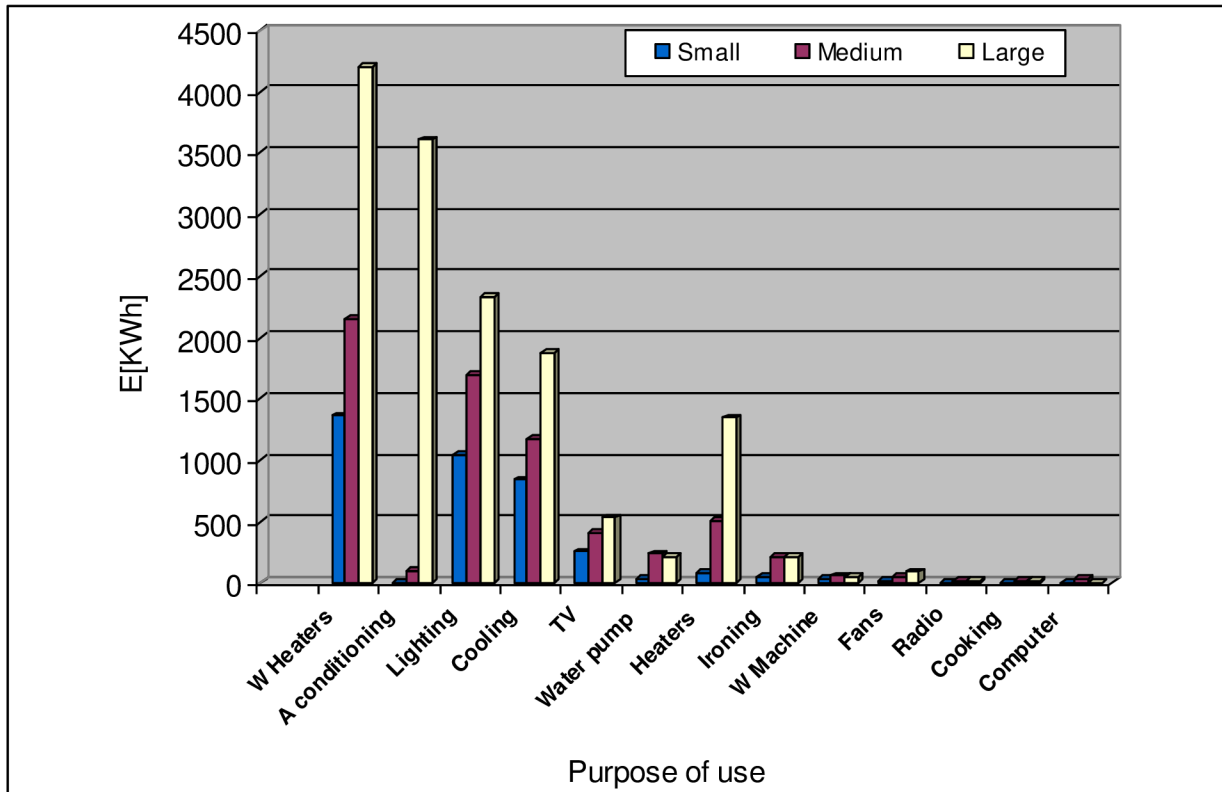

Fig. 11.3 Annual electrical energy consumption, depending of purpose of use, Benghazi

11.1.3 Consumers in Sabha

The sample in this region included 82 consumers, 13 of them were small, 27 of them were medium, and 42 were large consumers. Tab. 11.8 and Fig. 11.4 show the ratios of annual electrical energy consumption depending on the purpose of use. Clearly the highest rates of consumption are for air conditioning (27.73%) for small consumers, then lighting and water heating; for the medium consumers, the highest ratio was for water heating (25.69%), followed by lighting then air conditioning third; finally, for large consumers the highest rate of consumption was clearly for air conditioning (37.37%), then water heating and cooling. In Tab. 11.8 the use of air conditioning of small consumers can be seen to be contrary to the situation in the cities of Tripoli and Benghazi. This is because of the climatic conditions of the area, which is characterized by high temperatures in summer and low temperatures in winter [38].

Tab. 11.8 Proportion of annual electrical energy consumption depending on the purpose of use of Sabha City

The purpose of use	Power percentage (%) & kWh of total consumption for each category					
	Small consumptions		Medium consumptions		Large consumptions	
	[%]	[kWh]	[%]	[kWh]	[%]	[kWh]
Water heaters	17.44	689	25.69	1895	18.70	2791
Air conditioning	7.65	302	18.90	1394	37.37	5578
Lighting	22.14	875	20.08	1481	11.43	1706
Cooling	27.73	1096	18.62	1373	13.52	2018
TV	5.79	228	3.78	278	3.01	449
Water pump	2.89	114	1.08	79	2.81	419
Heaters	4.47	176	5.43	400	7.33	1094
Ironing	1.39	54	2.98	219	2.66	397
Washing Machine	0.93	36	0.61	45	0.27	40
Fans	8.07	319	2.30	169	2.24	334
Radio	0.43	17	0.40	29	0.28	41
Cooking	0.12	4	0.09	6	0.29	43
Computer	0.95	37	0.03	2	0.09	13
Average consumption [kWh]					14928	
Total consumption [kWh]	51396				626986	

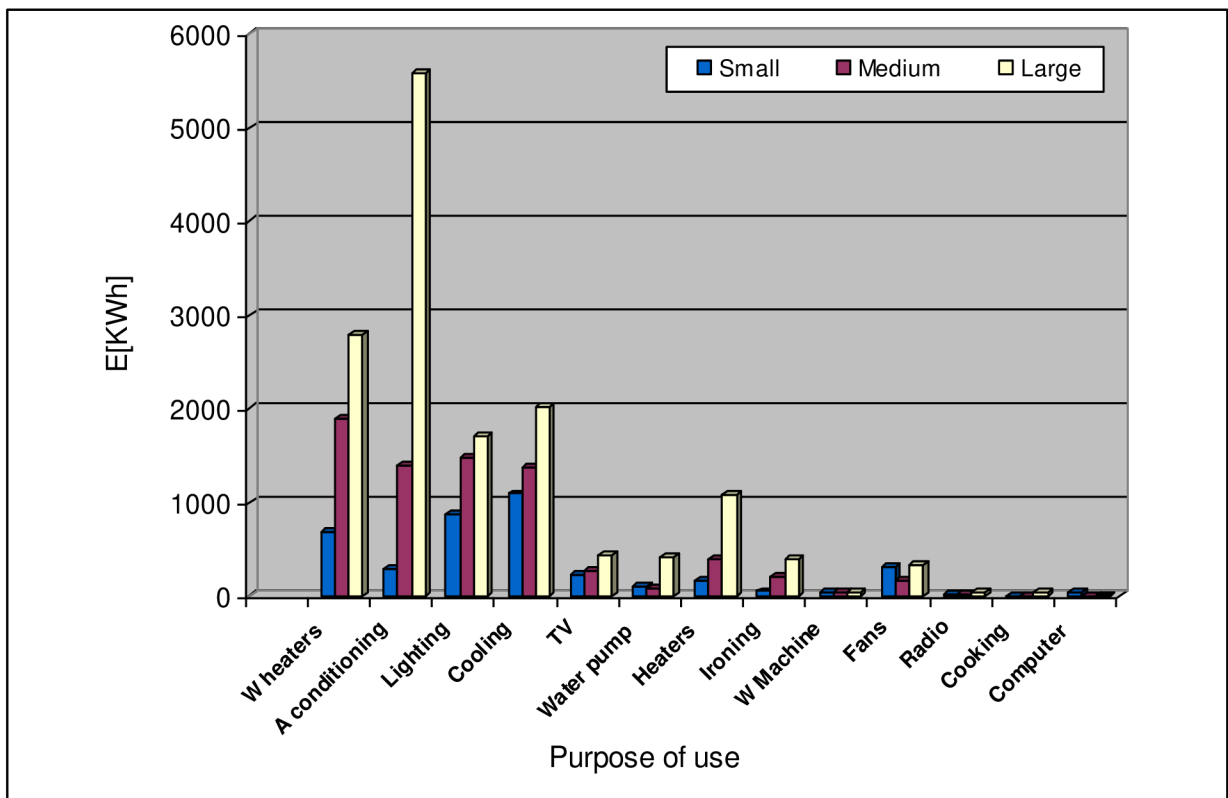

Fig. 11.4 Annual electrical energy consumption, depending of purpose of use, Sabha

11.2 Production costs and price reform

Production costs of electric energy unit (Dirham/kWh) by The General Electric Company of Libya in the past few years are shown in Tab. 11.9

Tab. 11.9 Production cost of electric energy unit

Year	Cost [Dirham/kWh]
2006	17
2007	19
2008	22

It is well established that energy demand is price sensitive, especially demand for electricity. The most reliable results come from industrialized countries. Price reform will save large quantities of energy, especially in the long-run and can make substantial reduction greenhouse gas emissions from countries with distorted prices [13].

Distorted prices also tend to devastate the state-owned enterprises that are normally a victim of the practice. Subsidies are widespread throughout the Libyan economy. Agriculture receives extensive state support through price subsidies. Water is heavily subsidized and so is energy. Petroleum product prices are subsidized by implicit consumer subsidies. The price of petroleum products to consumers in Libya is well below the international price for similar products. And this represents an implicit subsidy to petroleum products because the true value of the commodity to the country is measured by the value which it would achieve in its most valuable application.

Some attempt to reduce the level of subsidies has since been made, but they still are at a high level. Gasoline is sold at 20 Dirham/liter and diesel at 15 Dirham/liter. (100 Dirham = 1 Dinar; 1 euro = 1.8 Dinar, October 2009 exchange rates). Tab. 11.10 shows the evolution of fuel prices to the electricity sector over the past ten years. The efforts to bring prices closer to international prices are clearly visible.

Inflation has been subdued in Libya and there have been long periods of deflation so the prices rises are largely real [13].

Tab. 11.10 Historic fuel prices to the electricity sector 2001-2009 [Dinar/m³] [13]

	2001	2002-2005	2006	2007	2008	2009
Heavy fuel oil	18.4					36
Light fuel oil	26	36	56	66	86	150
Natural Gas	0.008405					0.02

Electricity prices are subsidized in two ways; GECOL receives fuel inputs at prices well below international prices, as noted above. This is an implicit subsidy that does not appear in the state accounts. In the past it also received capital from the state for free and this is an explicit subsidy that does appear in the state budget. The company appears now to incorporate depreciation in its cost base, but it is not entirely clear how the figures are calculated and whether the figures are realistic. The revenues from sales of electricity are insufficient to cover the costs of production and the deficit is also compensated by a direct financial transfer from the state.

GECOL has calculated costs by a set of assumptions that is based on the subsidized costs of fuel and making some allowance for depreciation; with these assumptions, the GECOL estimates its average cost per unit of electricity sold at around 64 Dirham/kWh. This takes into account the large commercial losses (around 25%) and the technical losses (13-14%), for which no revenue is received.

• **Tariff (Dirham/kWh)**

The tariff sales per kilowatt hour in the early years were fixed for all categories of consumption in the domestic sector and subsidized by the state, and due to the increase of consumption in the domestic sector and the price difference between the production cost of unit and sold price for domestic consumption. This let General Electric Company re-price the unit sale, and divide consumers into three categories, in order to be able to keep price subsidies for the small consumers. Tab. 11.11 shows these prices and categories.

The average revenue in 2008 from a domestic consumer was 23.6 Dirham/kWh; this value is close to the minimum tariff because the majority of consumers fall into the lowest band. Another consequence of the high threshold for the definition of the lowest tariff category is that the majority of customers receive the subsidy.

The tariffs for other major consuming groups are also well below the unit generating cost, including light industry (average revenue 42 Dirham/kWh) and heavy industry (31 Dirham/kWh). Only in the case of sales to commercial enterprises, the government and street lighting does the selling price exceed the average cost of generation [13].

Tab. 11.11 Unit price for various sectors [Dirham/kWh]

Year	domestic		Small agricultural	Large agricultural	Light Industrial	Heavy Industrial	Commercial	Public facilities	Street lighting
	Range	Price							
1995		20	15	15	15	10	30	30	30
1996		20	20	21	24	17	30	30	25
1997		20	25	27	33	24	42	42	40
1998		20	30	32	42	31	48	47	45
2000		20	30	32	42	31	48	47	45
2002		20	30	32	42	31	48	47	45
2003		20	30	32	42	31	48	47	45
2004	0-500	20							
	501-600	25							
	601-700	35	30	32	42	31	68	68	68
	701-800	40							
	801-900	45							
	901 and above	50							
2005	0-500	20							
	501-600	25							
	601-700	35	30	32	42	31	68	68	68
	701-800	40							
	801-900	45							
	901 and above	50							

2006	0-1000	20	30	32	42	31	68	68	68
	1001-1400	30							
	1401 and above	50							
2007	0-1000	20	30	32	42	31	68	68	68
	1001-1400	30							
	1401 and above	50							
2008	0-1000	20	30	32	42	31	68	68	68
	1001-1400	30							
	1401 and above	50							

11.3 Average Consumption

From Tab. 11.6, Tab. 11.7, Tab. 11.8 and Fig. 11.2 the annual energy consumption, depending of propose of use, can be seen. Tripoli indicates that the highest rates of energy consumption in the residential sector was for the purpose of water heating and space heating in winter and for air conditioning in the summer.

The average consumption for the purposes mentioned above for all members of the study sample can then be calculated, results can be found in Tab. 11.12, and Fig. 11.5 shows the average consumption, where electric energy is used to cover all these necessities. By applying formula 11.2 for each segments of customers (small, medium, large), for the purpose of water heating, space heating, and air conditioning.

$$Ave \text{ Cons}m = \frac{((T_{\text{Cons}m} \cdot T_{\text{Costm No}}) + (B_{\text{Cons}m} \cdot B_{\text{Costm No}}) + (S_{\text{Cons}m} \cdot S_{\text{Costm No}}))}{(T_{\text{Costm}} + B_{\text{Costm}} + S_{\text{Costm}})} \quad (11.2)$$

Where:

*Ave Cons*m: Average Consumption

$T_{\text{Cons}m}$: Tripoli consumption,

$T_{\text{Costm No}}$: Number of consumers in Tripoli

$B_{\text{Cons}m}$: Benghazi consumption,

$B_{\text{Costm No}}$: Number of consumers in Benghazi

$S_{\text{Cons}m}$: Sabha consumption,

$S_{\text{Costm No}}$: Number of consumers in Sabha

Example for small consumption and calculation of average consumption of water heater

$$\text{Water heating} = \frac{((1390 \cdot 112) + (1364 \cdot 43) + (690 \cdot 13))}{(112 + 43 + 13)} = 1333 \text{ kWh}$$

Tab. 11.12 Average consumption for average consumers [kWh]

Average Consumption	Small	Medium	Large
Water heating	1333	2025	3251
Air conditioning	23	592	5304
Space heating	44	381	914

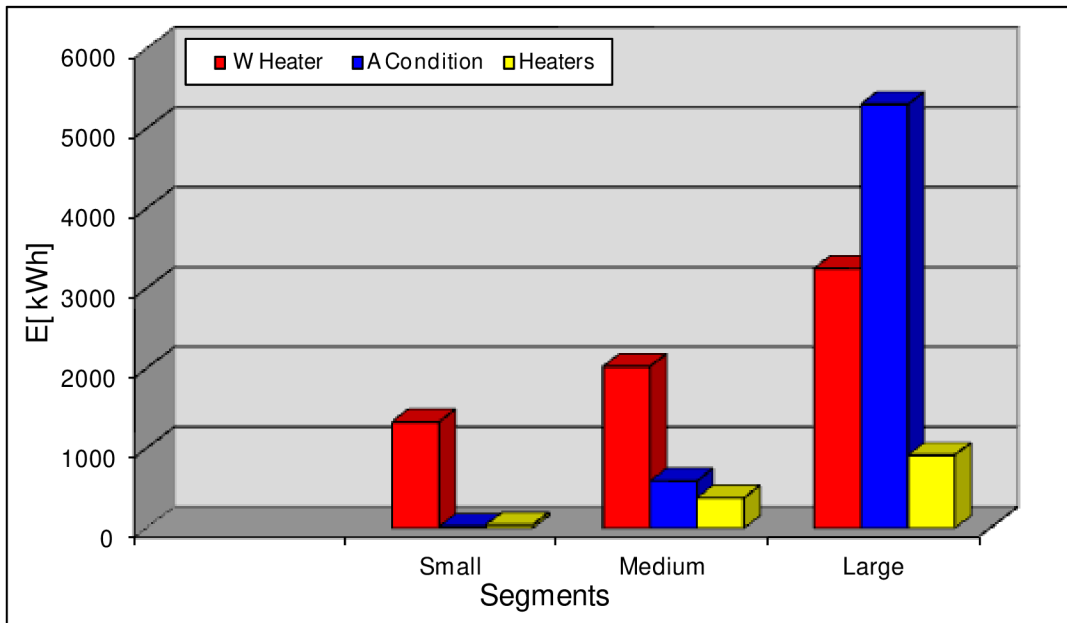

Fig. 11.5 Average Consumption for average consumers

From the study and its comparison of the proportion of ownership of electrical equipment for the purpose of water heating, space heating, and air conditioning, for each of the three segments of consumers, there is a considerable difference in ownership of equipment from family to family, with some who have one device and there who have five.

Then the average installed capacity for that equipment can be assumed, as shown in Tab. 11.13.

Tab. 11.13 Installed power [W]

	Small Consumption	Medium Consumption	Large Consumption
Water heating	1200 (1 unit)	2400 (2 units)	4800 (4 units)
Air Conditioning	1900 (1 unit)	3000 (2 units)	6700 (4 units)
Space heating	1200 (1 unit)	2400 (2 units)	3600 (3 units)

11.4 Heating and cooling system components

Central systems produce a heating and/or cooling effect in a single location. This effect must then be transmitted to the various spaces in a building that require conditioning. Three transmission media are commonly used in central systems: air, water, and steam. Hot air can be used as a heating medium, cold air as a cooling medium. Hot water and steam can be used as heating media, while cold water is a common cooling medium. A central system will always require distribution components to convey the heating or cooling effect from the source to the conditioned locations [30]. The system consists of a source of heat, distribution network, heat exchanger, control valve, emitters (radiator, diffuser), and storage tank. Fig. 11.6 shows the main components of a central heating system.

Central heating and cooling systems are more economical when using surplus heat from another source such as cogeneration, combustion engine, power plant, or geothermal; some

central systems produce heat from a conventional boiler, or use a direct fire absorption chiller as the cooling system.

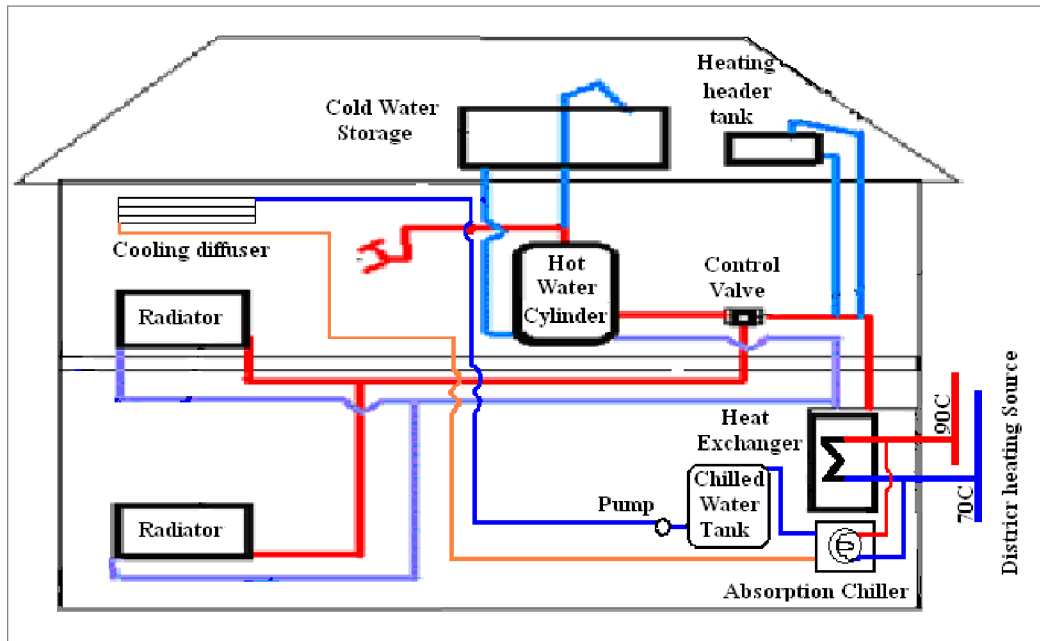

Fig. 11.6 Heating /cooling system for typical house

11.4.1 Source of heat

There are different energy sources that can be used for district heating, including industrial waste heat, geothermal, solar systems, and heat pumps, in addition to conventional boilers and cogeneration. Different types of heat sources are employed in buildings. Heat may be generated by the combustion of some flammable material (a fuel) such as coal or natural gas. Electricity may be converted to heat through the process of electric resistance [30].

A combined heat and power plant (CHP) which generates electricity using a steam turbine or an engine is probably the most common heat source. It heats the heating medium in the distribution network using the exhaust gases leaving the turbine.

The choice of a heat source for a given building situation is usually based upon source availability, required system capacity, and equipment and fuel costs [30].

11.4.2 Heat Exchanger

Heat exchanger are devices whose primary responsibility is the transfer (exchange) of heat, typically from one fluid to another. However, they are not only used in heating applications, such as space heaters, but are also used in cooling applications, such as refrigerators and air conditioners. Many types of heat exchangers can be distinguished from one another based on the direction the liquids flow. In such applications, the heat exchangers can be parallel-flow, cross-flow, or countercurrent. In parallel-flow heat exchangers, both fluids involved move in the same direction, entering and exiting the exchanger side by side. In cross-flow heat exchangers, the fluid paths run perpendicular to one another. In countercurrent heat exchangers, the fluid paths flow in opposite directions, with each exiting where the other enters. Countercurrent heat exchangers tend to be more effective than other types of exchangers [41]. Fig. 11.7 shows some types of heat exchanger.

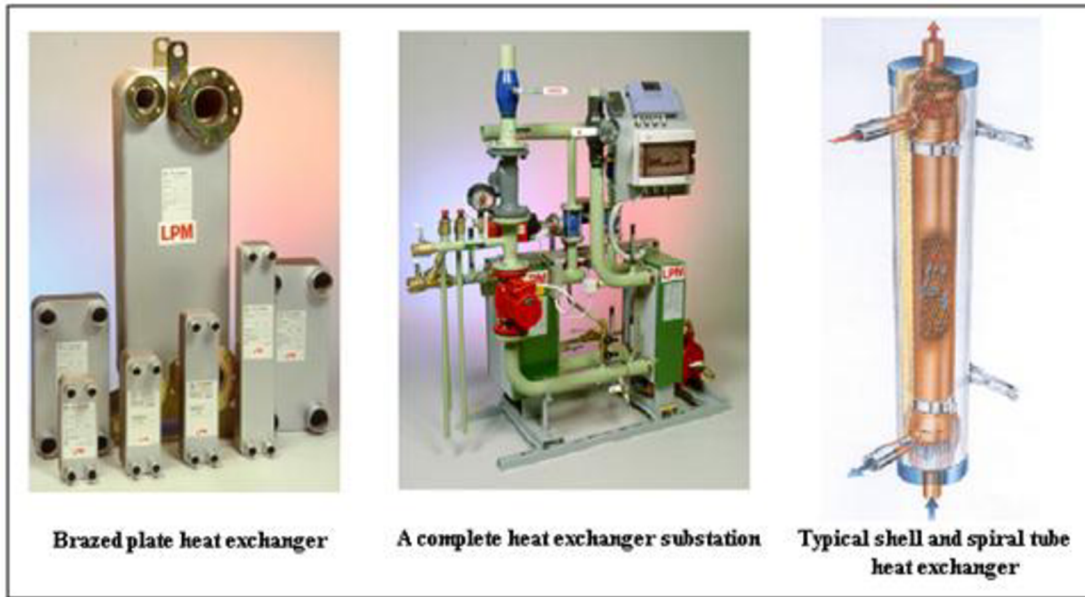

Fig. 11.7 Types of heat exchanger [42]

11.4.3 Distribution Components

Central systems produce a heating and/or cooling effect in a single location. This effect must then be transmitted to the various spaces in a building that require conditioning.

In a water-based central system, pipes are used to convey water from the source to the final delivery components. A minimum of two pipes is necessary, one for supply water and one for return water, to establish a distribution loop. Closed circuit loops are universally employed as it is more economical to heat or cool water in a closed loop than in an open system. When both heating and cooling are required in a building, 3-pipe and 4-pipe distribution systems may be used to increase system flexibility. A 2-pipe system can only heat or cool, simultaneous heating and cooling - not an uncommon requirement in large buildings - is not possible with a 2-pipe system. A 3-pipe system has two supply pipes (hot and cold water) and a single return. The mixing of heating and cooling water in a single return is not energy efficient and is not recommended. A 4-pipe distribution system has two supply pipes and two separate return pipes (hot and cold). The 4-pipe arrangement provides the greatest control flexibility in the most energy-efficient manner [30].

In an air-based central system, ducts (ductwork) are used to convey air from a primary or secondary source to the final delivery components. Typically, two duct paths are necessary, one for supply air and one for return air. Air distribution loops often re-circulate as much indoor air as possible, as it is more economical to heat or cool return air than outdoor air [30].

- **Open and close loop systems**

Most heating/chiller systems are closed loops, which mean that the same water is circulated in the pipe work again and again, and that the expansion tank is pressurized. A rubber membrane separates the compressed gas from the water in the system.

Open systems are very rare but are preferable if the heat source is, for example, a solid fuel boiler. In such cases, the system pressure is determined by the water column in the expansion tank [43].

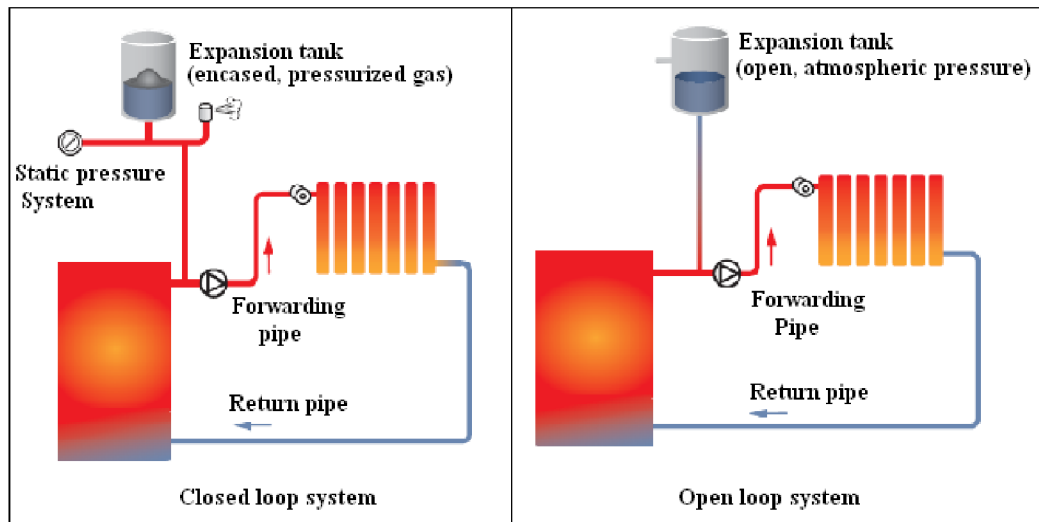

Fig. 11.8 Closed and Open loop systems [43]

- **Two-pipe systems**

In a two-pipe system the supply pipe is used to supply the heated or cooled water to the emitters, see Fig. 11.9, while the return pipe transports used water back to the heating or chiller source. One major advantage of two-pipe systems is that the water flow can be varied and controlled to save pump power. Another is that all radiators receive water of the same temperature, as the supply pipe feeds directly from the boiler [43].

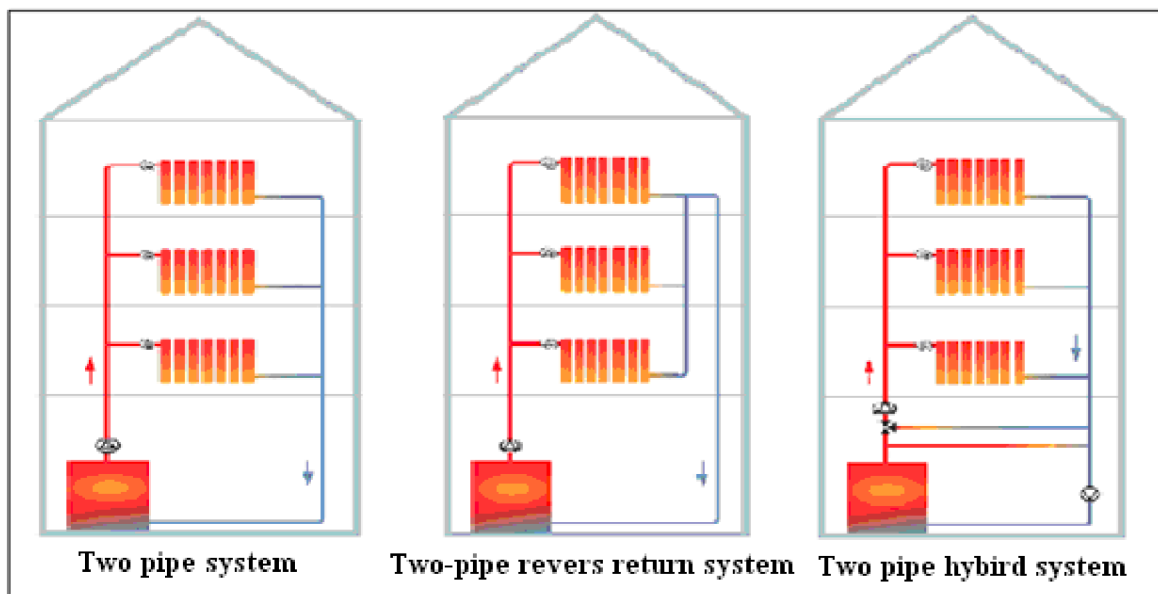

Fig. 11.9 Type of pipe distribution [43]

In hybrid systems, the principle is that there is a low loss head circuit and separate heating circuits, each with its own pump. Such systems are used to separate hydronic systems. The advantage is the fact that some boilers are sensitive to low temperatures and have a minimum flow limit. In order to minimize the time it takes for the water to reach the desired temperature, the water is circulated only in the low loss head circuit. When the desired temperature is reached, the radiator circuit opens. The 3-way valve regulates the flow either to the radiator circuits or to the boiler [43].

- **Hot water systems**

The most obvious difference in hot water systems, compared to most heating systems, is that they are open systems. To ensure quick delivery of hot water to any tap in a building see Fig. 11.10, the hot water system is often designed as a loop system, with a secondary return pipe. This also saves hot water and, consequently, energy [43].

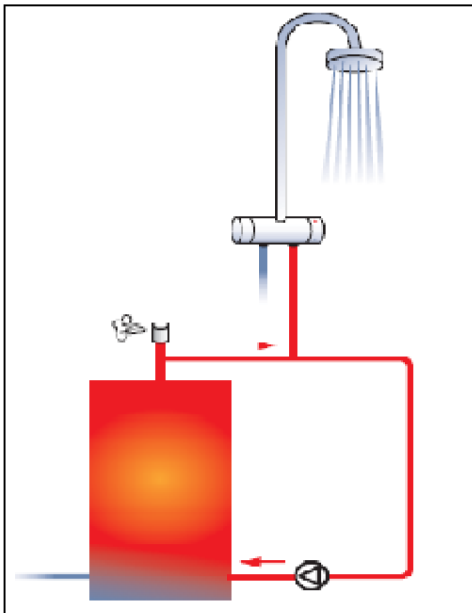

Fig. 11.10 Hot water system

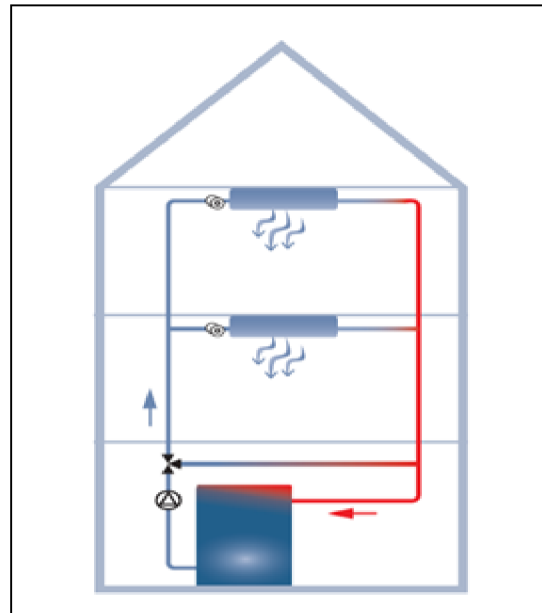

Fig. 11.11 Chiller system

- **Chiller systems**

The chiller system operates the same way as a hybrid heating system, but circulates cold media instead of hot, see Fig. 11.11. The chiller system depends to a large degree on the choice of cooling type. Different cooling systems have different densities and generate different levels of friction in the pipes. The most common cooling systems used are salinated water and water mixed with glycol. A chiller system is usually a hybrid system. Chiller systems often require a certain minimum flow, for example 30%, to eliminate the risk of ice build-up. As valves close, the differential head across the evaporator is reduced. A controller senses this and opens the bypass valve to maintain a minimum flow, mixing cold supply water with warm return water.

11.4.4 Delivery Components

The heating or cooling effect produced at a source and distributed by a central system to spaces throughout a building needs to be properly delivered to each space by the units called delivery equipments, such as:

- **Diffuser:** a diffuser is a device designed specifically to introduce supply air into a space, to provide good mixing of the supply air with the room air.
- **Register:** registers are similar to diffusers except that they are designed and used for floor or sidewall air supply applications or as return air inlets [30].
- **Baseboard Radiator:** a hydronic baseboard radiator may be used as the delivery device in a hot water or steam heating system. Hydronic baseboard units are similar in general appearance to electric resistance baseboard units. Finned tube heat exchange elements transfer heat from the hot water distribution system to the room air. Baseboard radiators induce natural convection as an important means of heat distribution within a space, with warmer air exiting at the top of the unit and cooler air entering at the bottom. Fig. 11.12 shows a typical hydronic baseboard radiator [30].



Fig. 11.12 Basic Classes of residential type baseboard emitters

- **Convactor:** a convactor, is basically a high capacity heat exchange element consisting of one or more finned-tube heat exchange elements, housing, and possibly a fan. Convectors are used in steam or water (hydronic) central heating systems to provide high capacity heat delivery.
- **Unit Heater:** a unit heater is an industrial style heat delivery device, consisting of a fan and coil packaged in housing, used in water or steam central heating systems.

Thermostat

The term "thermostat" commonly refers to any unit that controls the operation of a heating and cooling system. Thermostats are used to turn on heating or cooling systems to bring the home to a set temperature. In addition to basic temperature control, programmable thermostats can be

used to manage the timing of the system's functions, which can control overall energy use and cost.

11.5 Energy needed for average consumption of typical houses

From Tab. 11.12 the output energy for propose of use for water heating, space heating, and air conditioning can be calculated. It is supposed that the efficiency of water heaters and heaters are 98%, air conditioner energy efficiency ratio (EER=10) from datasheets of some type of air condition units (for more details see appendix A1). In Libya many types of air conditioner systems (window unit, split unit) are used, and the use of LG and Samsung units with EER= 9.7 and 9.8 around to 10 is widespread. For the calculation formula (9.3) with EER=10 was used. The result can find in Tab. 11.14

Tab. 11.14 Used energy for average consumption

Small Consumption						
	Input [kWh]	Output				
		[kWh]	[BTU]	[kJ]	[k cal]	[RT]
Water heating	1333	1306	4457418	4702824	1123250	
Space heating	44	43	147132	155232	37077	
Air condition	23		230000			19
Medium Consumption						
	Input [kWh]	Output				
		[kWh]	[BTU]	[kJ]	[K cal]	[RT]
Water heating	2025	1985	6771396	7144200	1706363	
Space heating	381	373	1274026	1344168	321049	
Air condition	592		5920000			493
Large Consumption						
	Input [kWh]	Output				
		[kWh]	[BTU]	[kJ]	[K cal]	[RT]
Water heating	3251	3186	10871016	11469528	2739450	
Space heating	914	896	3056324	3224592	770181	
Air condition	5304		53040000			4420

RT: Refrigeration Ton

11.5.1 Using of heat for covering the necessities of the typical house

By using the output from Tab. 11.14, one can compute energy input when using heat energy instead of electric energy to cover same necessities, supposing the system efficiencies (Heat exchanger) for water heating 98% and for space heating 95%. Then to compute the energy requirement for cooling, Absorption chillers efficiencies ratio (COP) from datasheets of some absorption chillier units are range from 0.65 to 0.7 for single effect and range from 1.0 to 1.2 for double effect [53][44]. By using formula (9.1) with COP = 0.7 for single effect, and COP = 1.2 for double effect, the results are shown in Tab. 11.15

Tab. 11.15 Energy needed when use heat energy instead electric

Small Consumption					
	Output			Input	
	[kWh]	[RT]	[BUT]	[kWh]	[kJ]
Water heating	1306		4457418	1333	4798800
Space heating	43		147132	45	162000
Air condition		19	230000	96 56*	346661 202219*
Medium Consumption					
	Output			Input	
	[kWh]	[RT]	[BTU]	[kWh]	[kJ]
Water heating	1985		6773101	2025	7290000
Space heating	373		1272729	393	1414800
Air condition		493	5920000	2479 1446*	8922758 5204942*
Large Consumption					
	Output			Input	
	[kWh]	[RT]	[BTU]	[kWh]	[kJ]
Water heating	3186		10871083	3251	11703600
Space heating	896		3057279	943	3394800
Air condition		4420	53040000	22206 13667*	79943089 46633468*

Number with sign * = using double effect absorption chiller.

Then the energy prices and comparison between using electric and heat energy can be computed. For the calculation, Czech prices were used because energy is not sold as heat form in Libya yet, and thus this comparison cannot be made according Libyan prices. The Czech prices are set as 5 CZK/kWh, 600 CZK/GJ. The results can be seen in Tab. 11.16 with the note that when heat energy is used for water heating and space heating, the prices were cheaper than using electricity. But in case of the usage for cooling space it was higher when heat energy was used to drive absorption chillers, with both single and double effect.

Tab. 11.16 Cost of energy (Heat and Electric)

Small Consumption					
	Input		Cost [CZK]		Cost difference [CZK]
	[kWh]	[GJ]	Electricity	Heat	
Water heating	1333	4.7988	6665	2879	3786
Space heating	44	0.162	220	97	123
Air condition	23	0.346661	115	208	-93
		0.202219*	115	121	-6
Medium Consumption					
	Input		Cost [CZK]		Cost difference [CZK]
	[kWh]	[GJ]	Electricity	Heat	
Water heating	2025	7.29	10125	4374	5751
Space heating	381	1.4148	1905	849	756
Air condition	592	8.922758	2960	5354	-2394
		5.204942*	2960	3123	-163

Large Consumption					
	Input		Cost [CZK]		Cost difference [CZK]
	[kWh]	[GJ]	Electricity	Heat	
Water heating	3251	11.7036	16255	7022	9233
Space heating	914	3.3948	4570	2036	2534
Air condition	5304	79.943089	26520	47966	-21446
		46.633468*	26520	27980	-1460

But when comparing the whole system: water heating, space heating, air conditioning, the prices when heat was used are cheaper than electricity, except one case of the large consumption segment with single effect absorption chiller, where they are higher than when electricity is used. The results are in Tab. 11.17

Tab. 11.17 Total cost of electric energy and heat energy with single and double stage

Segments of consumption	Propose of use	Electricity Cost [CZK]	Heat Cost [CZK]		
			Heat	Single effect	Double effect
Small Consumption	Water heating	6665	2879	--	--
	Space heating	220	97	--	--
	Air condition	115	--	208	121
	Total	7000	--	3184	3097
Medium Consumption	Water heating	10125	4374	--	--
	Space heating	1905	849	--	--
	Air condition	2960	--	5354	3123
	Total	14990	--	10577	8643
Large Consumption	Water heating	16225	7022	--	--
	Space heating	4570	2036	--	--
	Air condition	26520	--	47966	27980
	Total	47315	--	57024	37038

It is not possible to make a comparison of electricity and heat used to cover the necessities of family consumption (domestic hot water, space heating, air condition) based on the previous case study because the amount of installed power is not clear. There is also the problem of house coverage for space heating (mobile heating units, other heating media). A comparison is only possible supposing the installation of electric space heating units in each place in house to be similar to a space heating system using heat energy.

11.6 Heat Loss and installed power of typical houses

Libyan houses can be divided into three segments, small, medium which is the vast majority, and large. In this chapter, in order to make comparisons between different systems and calculate the energy consumption, we assume that a small house consists of two bedrooms, one living room, one kitchen, one bathroom and corridor, with a total area ranging between 120 to 150 m²; a medium house consists of three bedrooms and two living rooms, kitchen, two bathrooms and two

corridors, with a total area ranging from 180 to 220 m²; a large house consists of five bedrooms, three bathrooms, four corridors, two kitchens. The design is of the large house is similar to that of the medium house, just differently laid out. The large house consists of two floors, with a total area ranging from 250 to 300m².

11.6.1 Small House

As mentioned above, the example for a small segment house consists of two bedrooms (5m Length, 4 Width, 3.2 Height), one living room (6m Length, 5 Width, 3.2 Height), one kitchen (4m Length, 4 Width, 3.2 Height), one bathroom (3m Length, 2 Width, 3.2 Height), and corridor (4m Length, 2 Width, 3.2 Height) with a total area of 119 m². See Fig. 11.13, Fig. 11.14, Fig. 11.15

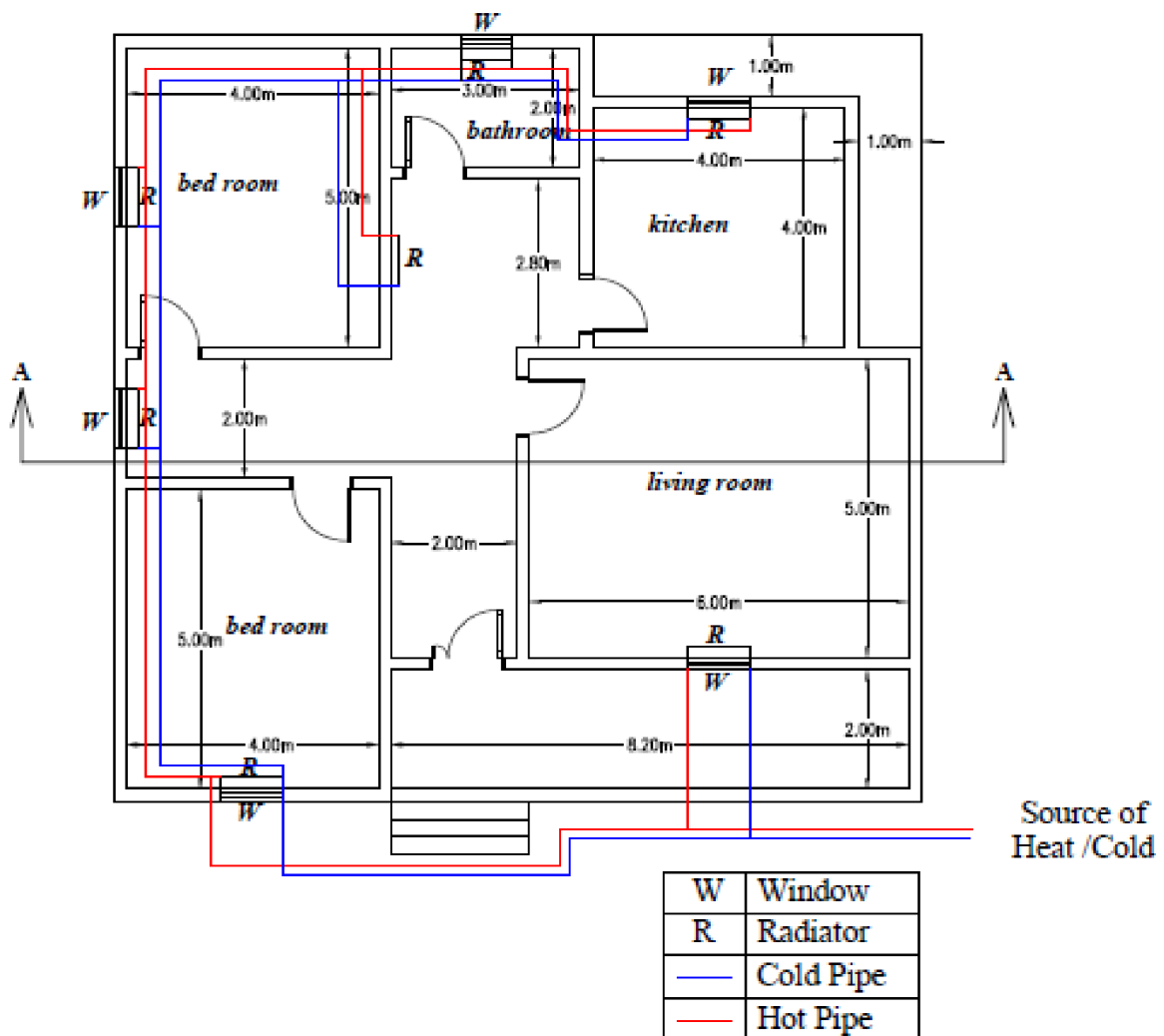

Fig. 11.13 Scheme for small house (Horizontal view)

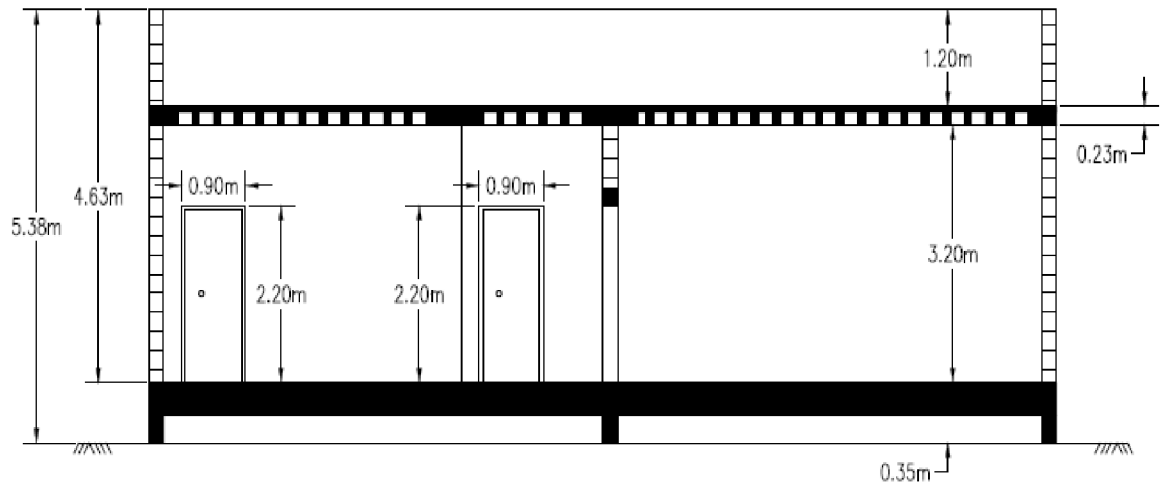

Fig. 11.14 Cross section A-A of building



Fig. 11.15 Three-dimensional model of small house

Calculating the heat loss for three sizes of houses, by using online heat losses calculator [45], gives results as shown in Tab. 11.19, Tab. 11.22, Tab. 11.25.

Tab. 11.18 Small house measurements and indoor and outdoor temperature

Room	Room type	T _{Int} [°C]	T _{Ext} [°C]	Length [m]	Width [m]	Height [m]	Area [m ²]
1	Bedroom60W/m ²	20	-1	5	4	3.2	20
2	Bedroom60W/m ²	20	-1	5	4	3.2	20
3	Livingroom60W/m ²	20	-1	6	5	3.2	30
4	Kitchen60W/m ²	20	-1	4	4	3.2	16
5	Bathroom70W/m ²	20	-1	3	2	3.2	6
6	Hall/Landing60W/m ²	20	-1	5	2	3.2	10
7	Hall/Landing60W/m ²	20	-1	4	2	3.2	8
8	Hall/Landing60W/m ²	20	-1	3	3	3.2	9

Tab. 11.19 Heat loss of small house

Window Area [m ²]	Window type	Wall Ext	No of Ext Walls	Floor type	Ceiling type	Heat Loss [kW]
1	Single Glazed wood/plastic	Unfilled Cavity	2	Solid Cement <(7.5×7.5)	Flat uninsulated	2.30
1	Single Glazed wood/plastic	Unfilled Cavity	2	Solid Cement <(7.5×7.5)	Flat uninsulated	2.30
1	Single Glazed wood/plastic	Unfilled Cavity	2	Solid Cement <(7.5×7.5)	Flat uninsulated	3.09
1	Single Glazed wood/plastic	Unfilled Cavity	2	Solid Cement <(7.5×7.5)	Flat uninsulated	1.85
0.9	Single Glazed wood/plastic	Unfilled Cavity	1	Solid Cement <(7.5×7.5)	Flat uninsulated	0.73
0	-----	Unfilled Cavity	1	Solid Cement <(7.5×7.5)	Flat uninsulated	1.12
0.9	Single Glazed wood/plastic	Unfilled Cavity	1	Solid Cement <(7.5×7.5)	Flat uninsulated	0.95
0	-----	Unfilled Cavity	0	Solid Cement <(7.5×7.5)	Flat uninsulated	0.52
Calculate Total Heat Loss						12.86
Total heat loss include pipe loss						16.42
Installed Boiler				17.11[kW]		

The power of radiators was calculated by multiplying of heat loss by 1.11. The total heat loss including pipe loss was calculated as sum of power of radiators multiplied by 1.15, and the installed boiler was calculated as a total heat loss including pipe loss in kW multiplied by 1.04, see Fig. 11.16 and Fig. 11.17.

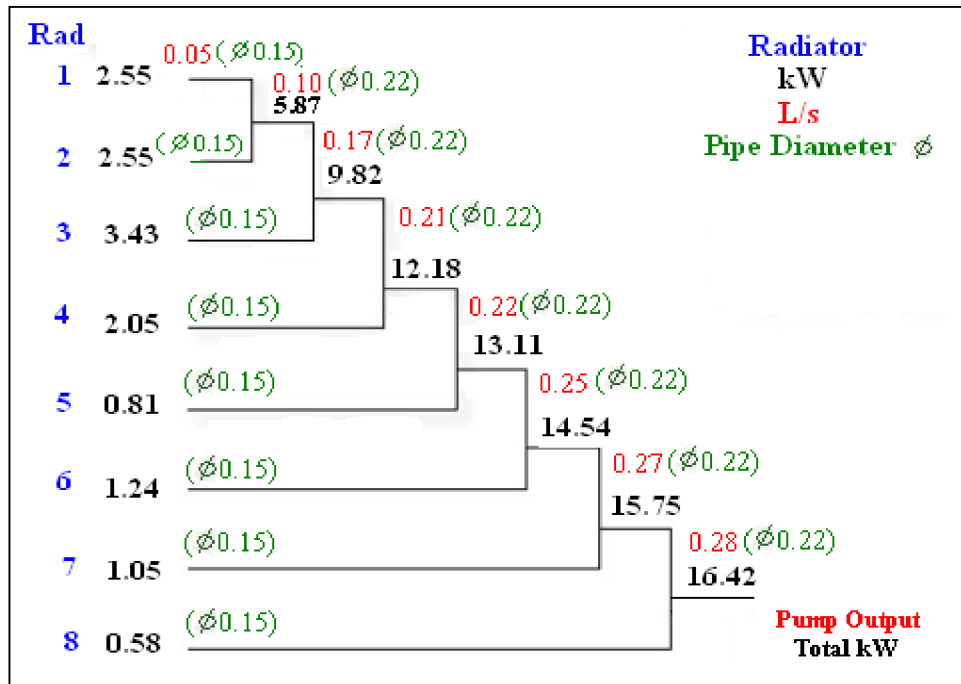

Fig. 11.16 Power flow in the system of small house network

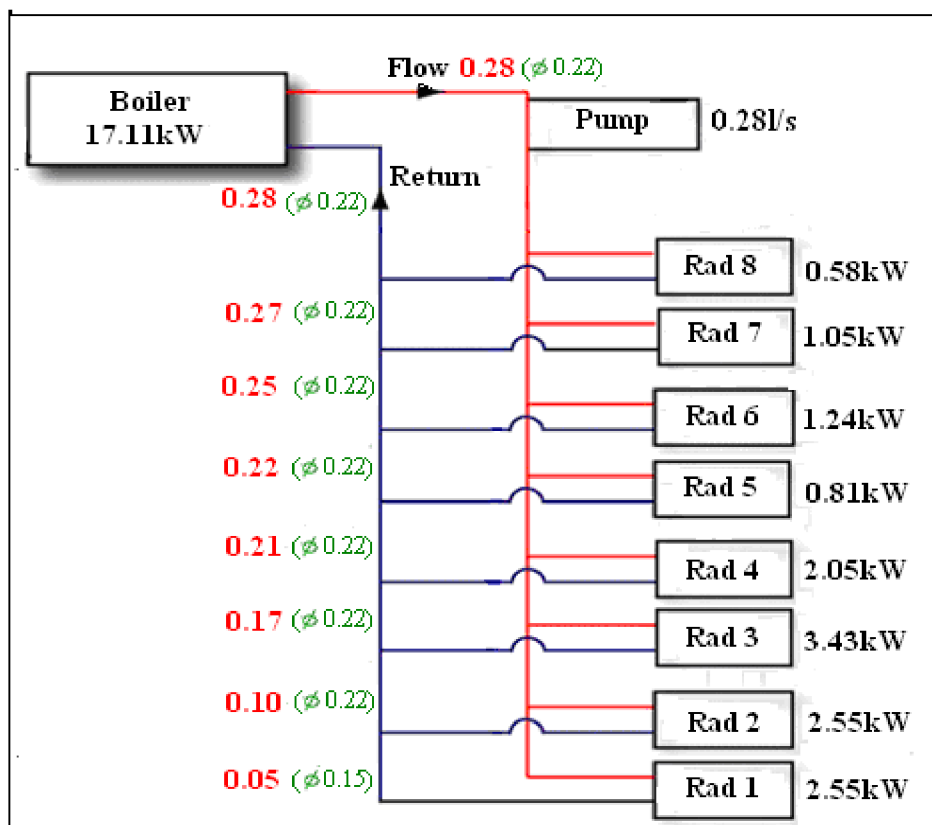

Fig. 11.17 Heating system of small house

Tab. 11.20 Installed power for space heating of small house

No	Room type	L _{nth}	W _{dth}	H _{ght}	Area m ²	Heat Loss [kW]	Power of radiator Calculated [kW]	Installed Power [kW]
1	Bedroom 1	5	4	3.2	20	2.30	2.55	2.8
2	Bedroom 2	5	4	3.2	20	2.30	2.55	2.8
3	Living room	6	5	3.2	30	3.09	3.43	3.5
4	Kitchen	4	4	3.2	16	1.85	2.05	2.2
5	Bathroom	3	2	3.2	6	0.73	0.81	1
6	Corridors	5	2	3.2	10	1.12	1.24	1.3
7	Corridors	4	2	3.2	8	0.95	1.05	1.2
8	Corridors	3	3	3.2	9	0.52	0.58	0.8
Total						12.86	14.26	15.6

11.6.2 Medium House

The typical Libyan house for the medium segment consists of three bedrooms (5m Length, 4 Width, 3.2 Height), two living rooms (6m Length, 5 Width, 3.2 Height), one kitchen (4m Length, 4 Width, 3.2 Height), two bathrooms (3m Length, 2 Width, 3.2 Height), and corridors (5m Length, 2 Width, 3.2 Height) with a total area of 182.75 m². See Fig. 11.18, Fig. 11.19, Fig. 11.20.

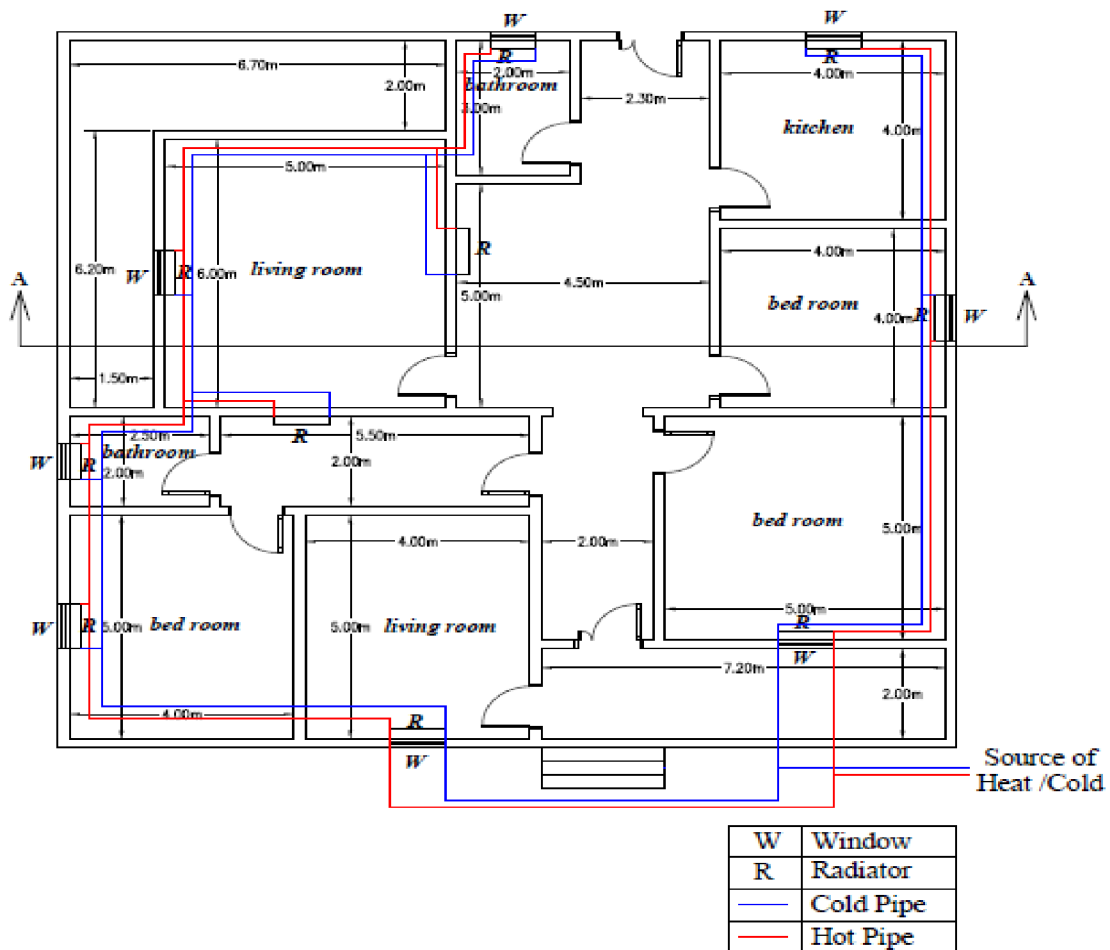

Fig. 11.18 Scheme for medium house

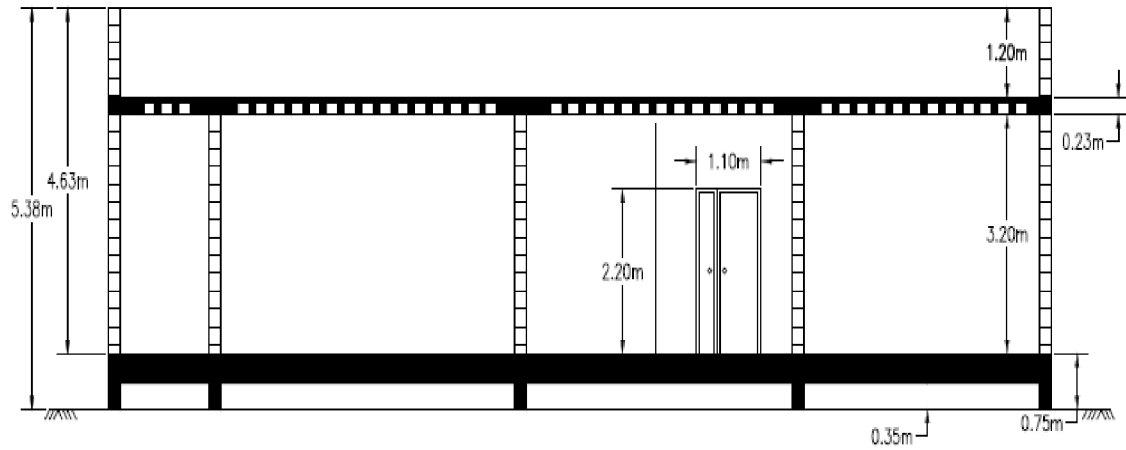

Fig. 11.19 Cross section A-A of the building



Fig. 11.20 Three-dimensional model of medium house

Tab. 11.21 Medium house measurements and indoor and outdoor temperature

Room	Room type	T _{Int} [°C]	T _{Ext} [°C]	Length [m]	Width [m]	Height [m]	Area [m ²]
1	Bedroom60W/m ²	20	-1	5	4	3.2	20
2	Bedroom60W/m ²	20	-1	5	5	3.2	25
3	Bedroom60W/m ²	20	-1	4	4	3.2	16
4	Livingroom60W/m ²	20	-1	6	5	3.2	30
5	Livingroom60W/m ²	20	-1	5	4	3.2	20
6	Kitchen60W/m ²	20	-1	4	4	3.2	16
7	Bathroom70W/m ²	20	-1	2	3	3.2	6
8	Bathroom70W/m ²	20	-1	2.5	2	3.2	5
9	Hall/Landing60W/m ²	20	-1	5.5	4.5	3.2	24.75
10	Hall/Landing60W/m ²	20	-1	5	2	3.2	10
11	Hall/Landing60W/m ²	20	-1	5	2	3.2	10

Tab. 11.22 Heat loss of medium house

Window Area [m ²]	Window type	Wall Ext	No of Ext Walls	Floor type	Ceiling type	Heat Loss [kW]
1	Single Glazed wood/plastic	Unfilled Cavity	2	Solid Cement <(7.5×7.5)	Flat uninsulated	2.30
1	Single Glazed wood/plastic	Unfilled Cavity	2	Solid Cement <(7.5×7.5)	Flat uninsulated	2.59
1	Single Glazed wood/plastic	Unfilled Cavity	1	Solid Cement <(7.5×7.5)	Flat uninsulated	1.42
1	Single Glazed wood/plastic	Unfilled Cavity	2	Solid Cement <(7.5×7.5)	Flat uninsulated	3.09
1	Single Glazed wood/plastic	Unfilled Cavity	1	Solid Cement <(7.5×7.5)	Flat uninsulated	1.76
1	Single Glazed wood/plastic	Unfilled Cavity	2	Solid Cement <(7.5×7.5)	Flat uninsulated	1.85
0.9	Single Glazed wood/plastic	Unfilled Cavity	1	Solid Cement <(7.5×7.5)	Flat uninsulated	0.62
0.9	Single Glazed wood/plastic	Unfilled Cavity	1	Solid Cement <(7.5×7.5)	Flat uninsulated	0.62
0	-----	Unfilled Cavity	1	Solid Cement <(7.5×7.5)	Flat uninsulated	2.03
0	-----	Unfilled Cavity	1	Solid Cement <(7.5×7.5)	Flat uninsulated	0.58
0	-----	Unfilled Cavity	0	Solid Cement <(7.5×7.5)	Flat uninsulated	0.58
Calculate Total Heat Loss						17.44
Total heat loss include pipe loss						22.26
Installed Boiler				23.22 [kW]		

The power of radiators was calculated by multiplying heat loss by 1.11. The total heat loss including pipe loss was calculated as the sum of the power of the radiators multiplied by 1.15, and the install boiler was calculated as a total heat loss including pipe loss in kW multiplied by 1.04, see Fig. 11.21, Fig. 11.22.

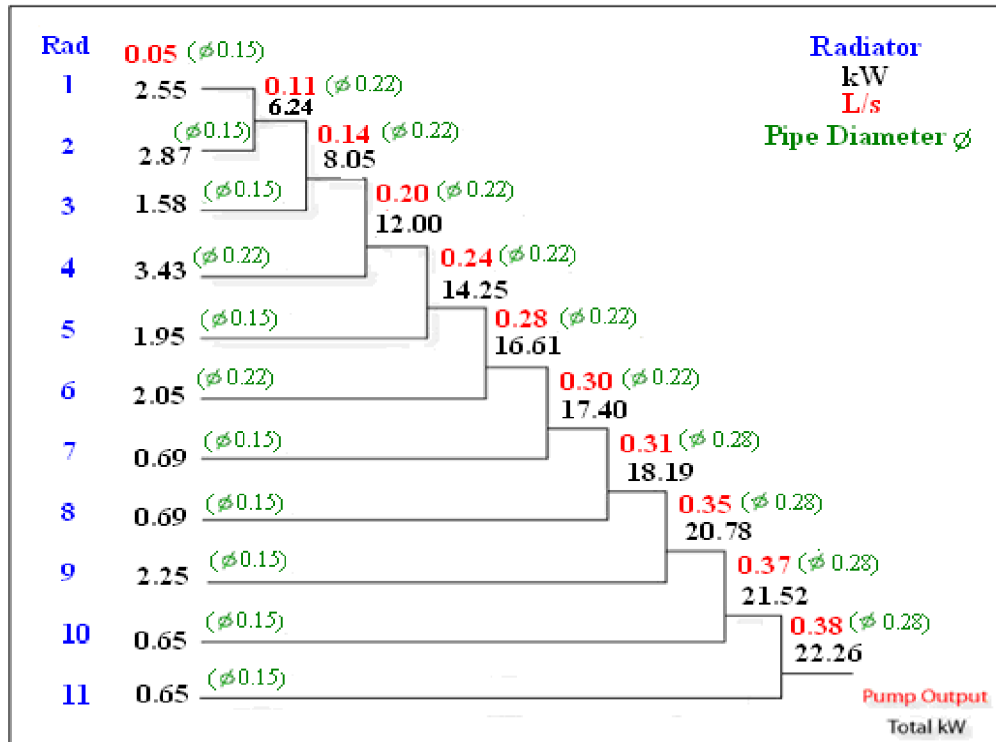

Fig. 11.21 Power flow in the system of medium house

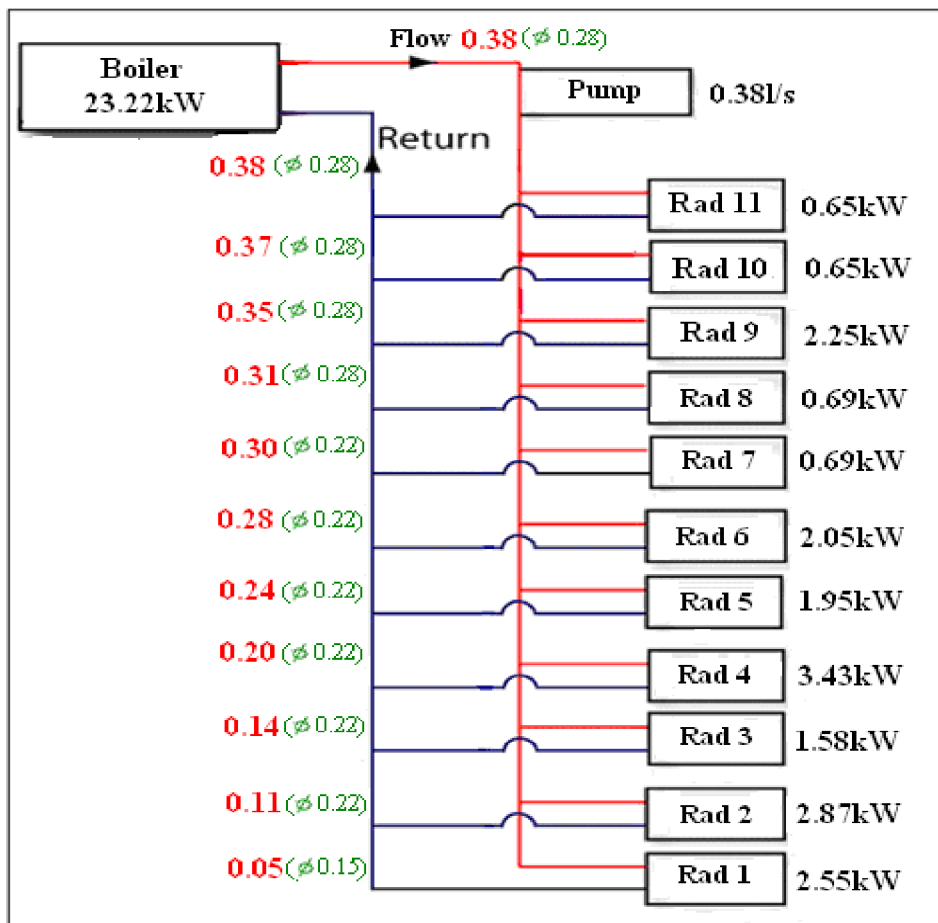

Fig. 11.22 Heating system of medium house

Tab. 11.23 Installed power for space heating of medium house

No	Room type	L _{nth}	W _{dth}	H _{ght}	Area m ²	Heat loss [kW]	Power of radiator calculated [kW]	Installed Power [kW]
1	Bedroom	5	4	3.2	20	2.30	2.55	2.8
2	Bedroom	5	5	3.2	25	2.59	2.87	3
3	Bedroom	4	4	3.2	16	1.42	1.58	1.8
4	Living Room	6	5	3.2	30	3.09	3.43	3.7
5	Living Room	5	4	3.2	20	1.76	1.95	2
6	Kitchen	4	4	3.2	16	1.85	2.05	2.3
7	Bathroom	2	3	3.2	6	0.62	0.69	0.8
8	Bathroom	2.5	2	3.2	5	0.62	0.69	0.8
9	Corridor	5.5	4.5	3.2	24.75	2.03	2.25	2.5
10	Corridor	5	2	3.2	10	0.58	0.64	0.8
11	Corridor	5	2	3.2	10	0.58	0.64	0.8
Total						17.44	19.34	21.3

11.6.3 Large House

The typical Libyan house for the large segment consists of five bedrooms (5m Length, 4 Width, 3.2 Height), two living rooms (6m Length, 5 Width, 3.2 Height), two kitchens (4m Length, 4 Width, 3.2 Height), three bathrooms (3m Length, 2 Width, 3.2 Height), and four corridors (5m Length, 2 Width, 3.2 Height) with a total area of 270.5 m². See Fig. 11.23, Fig. 11.25, Fig. 11.26.

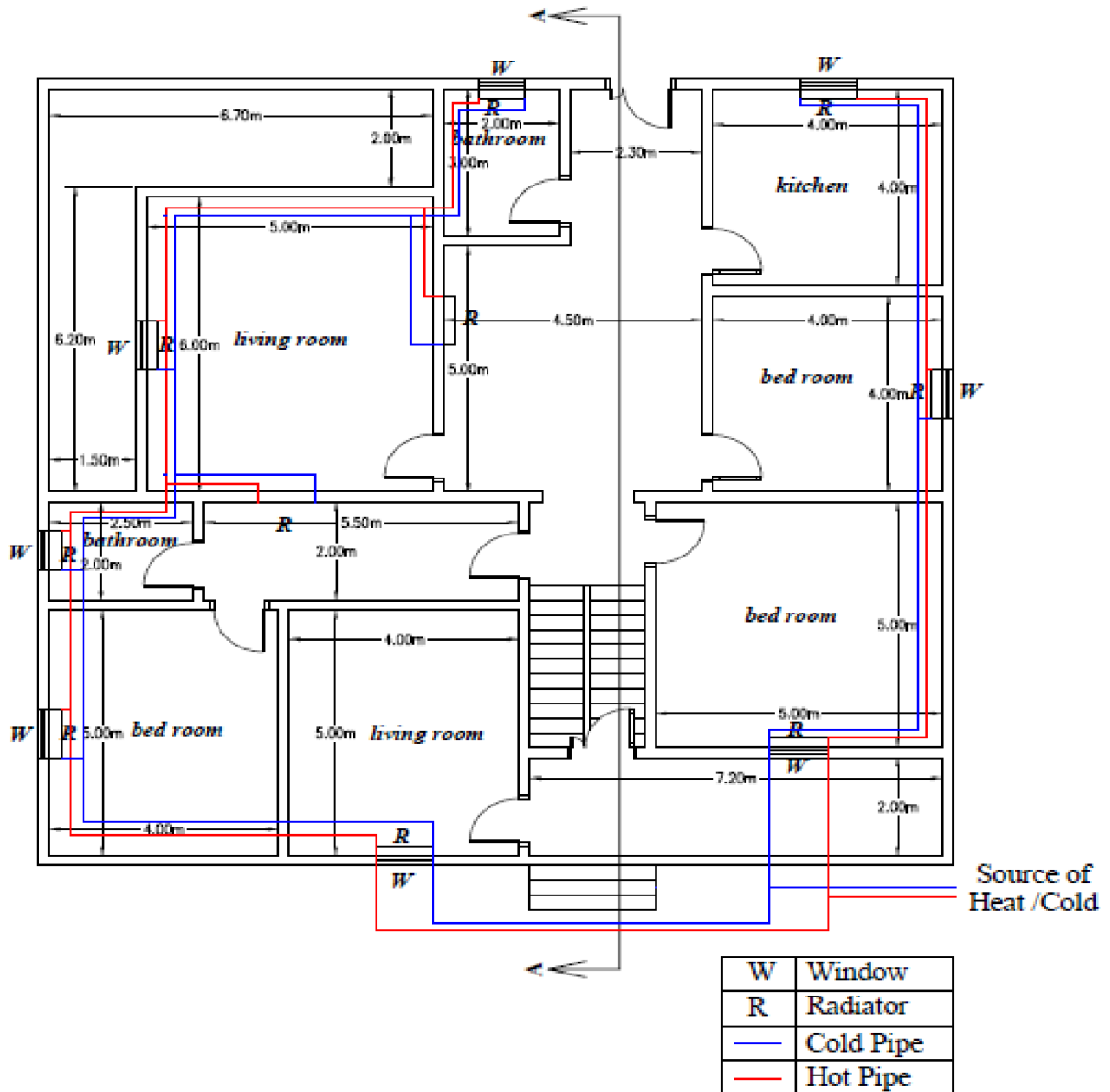

Fig. 11.23 Scheme for large house ground floor

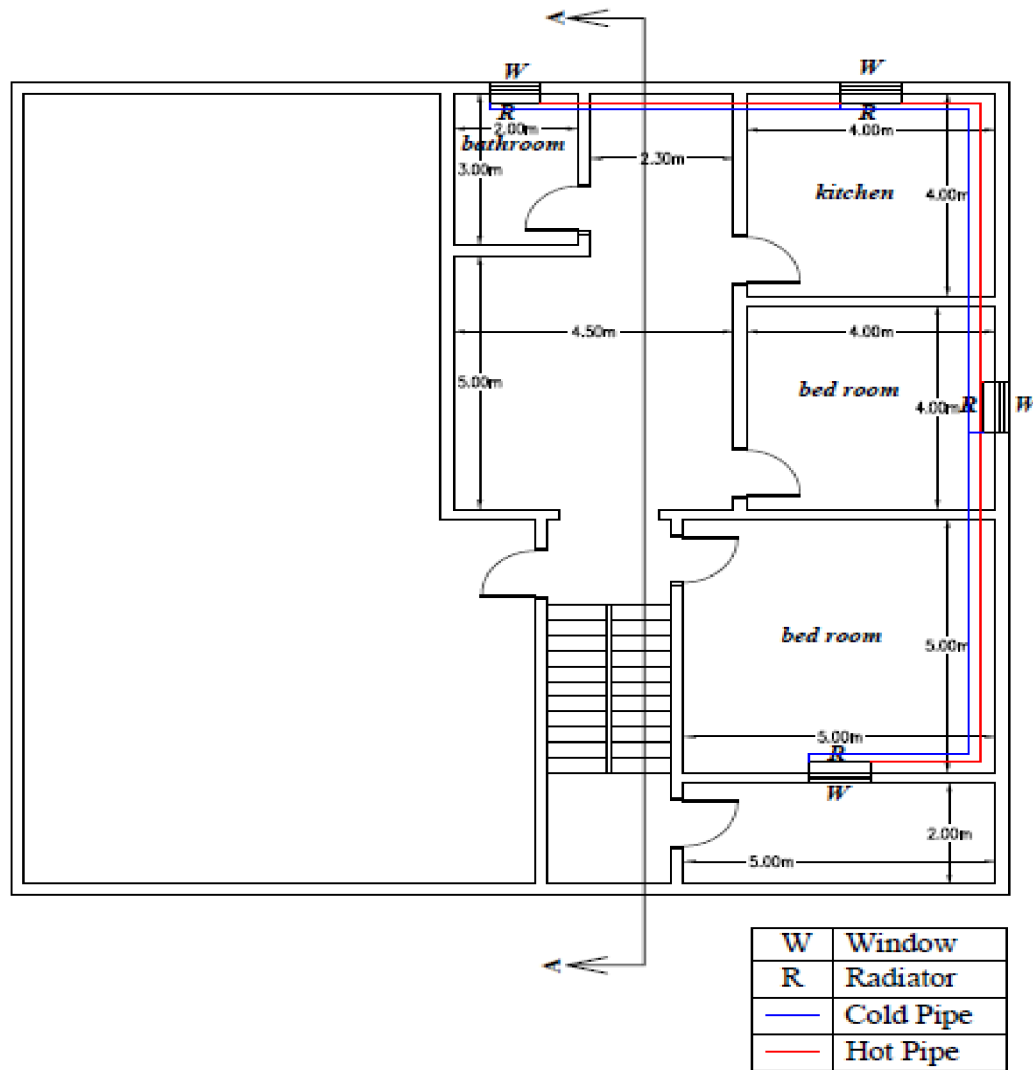

Fig. 11.24 Scheme of Large House first floor

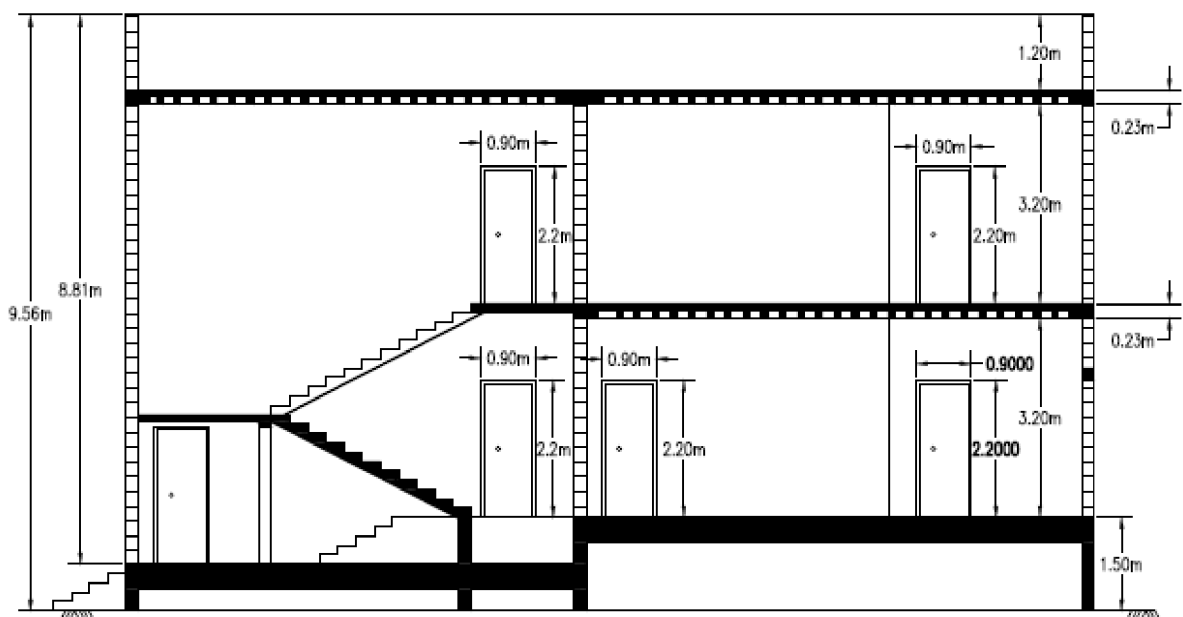

Fig. 11.25 Cross section A-A of the building



Fig. 11.26 Three-dimensional model of large house

Tab. 11.24 Large house measurements and indoor and outdoor temperature

Room	Room type	T_{Int} [°C]	T_{Ext} [°C]	Length [m]	Width [m]	Height [m]	Area [m ²]
1	Bedroom60W/m ²	20	-1	5	4	3.2	20
2	Bedroom60W/m ²	20	-1	5	5	3.2	25
3	Bedroom60W/m ²	20	-1	4	4	3.2	16
4	Bedroom60W/m ²	20	-1	4	4	3.2	16
5	Bedroom60W/m ²	20	-1	5	5	3.2	25
6	Livingroom60W/m ²	20	-1	6	5	3.2	30
7	Livingroom60W/m ²	20	-1	5	4	3.2	20
8	Kitchen60W/m ²	20	-1	4	4	3.2	16
9	Kitchen60W/m ²	20	-1	4	4	3.2	16
10	Bathroom70W/m ²	20	-1	3	2	3.2	6
11	Bathroom70W/m ²	20	-1	3	2	3.2	6
12	Bathroom70W/m ²	20	-1	2.5	2	3.2	5
13	Hall/Landing60W/m ²	20	-1	5.5	4.5	3.2	24.75
14	Hall/Landing60W/m ²	20	-1	5.5	4.5	3.2	24.75
15	Hall/Landing60W/m ²	20	-1	5	2	3.2	10
16	Stairs room60W/m ²	20	-1	5	2	6.4	10

Tab. 11.25 Heat loss of large house

Window Area [m ²]	Window type	Wall Ext	No of Ext Walls	Floor type	Ceiling type	Heat Loss [kW]
1	Single Glazed wood/plastic	Unfilled Cavity	2	Solid Cement <(7.5×7.5)	Flat uninsulated	2.30
1	Single Glazed wood/plastic	Unfilled Cavity	2	Solid Cement <(7.5×7.5)	Flat uninsulated	1.86
1	Single Glazed wood/plastic	Unfilled Cavity	1	Solid Cement <(7.5×7.5)	Flat uninsulated	0.96
1	Single Glazed wood/plastic	Unfilled Cavity	1	Solid Cement <(7.5×7.5)	Flat uninsulated	0.96
1	Single Glazed wood/plastic	Unfilled Cavity	2	Solid Cement <(7.5×7.5)	Flat uninsulated	1.86
1	Single Glazed wood/plastic	Unfilled Cavity	2	Solid Cement <(7.5×7.5)	Flat uninsulated	3.09
1	Single Glazed wood/plastic	Unfilled Cavity	1	Solid Cement <(7.5×7.5)	Flat uninsulated	1.76
1	Single Glazed wood/plastic	Unfilled Cavity	2	Solid Cement <(7.5×7.5)	Flat uninsulated	1.39
1	Single Glazed wood/plastic	Unfilled Cavity	2	Solid Cement <(7.5×7.5)	Flat uninsulated	1.39
0.9	Single Glazed wood/plastic	Unfilled Cavity	1	Solid Cement <(7.5×7.5)	Flat uninsulated	0.45
0.9	Single Glazed wood/plastic	Unfilled Cavity	1	Solid Cement <(7.5×7.5)	Flat uninsulated	0.45
0.9	Single Glazed wood/plastic	Unfilled Cavity	1	Solid Cement <(7.5×7.5)	Flat uninsulated	0.62
0	Single Glazed wood/plastic	Unfilled Cavity	1	Solid Cement <(7.5×7.5)	Flat uninsulated	1.31
0	-----	Unfilled Cavity	1	Solid Cement <(7.5×7.5)	Flat uninsulated	1.31
0	-----	Unfilled Cavity	0	Solid Cement <(7.5×7.5)	Flat uninsulated	0.37
0	-----	Unfilled Cavity	1	Solid Cement <(7.5×7.5)	Flat uninsulated	0.80
Calculate Total Heat Loss						20.88
Total Heat Loss include pipe loss						26.65
Installed Boiler				27.82 [kW]		

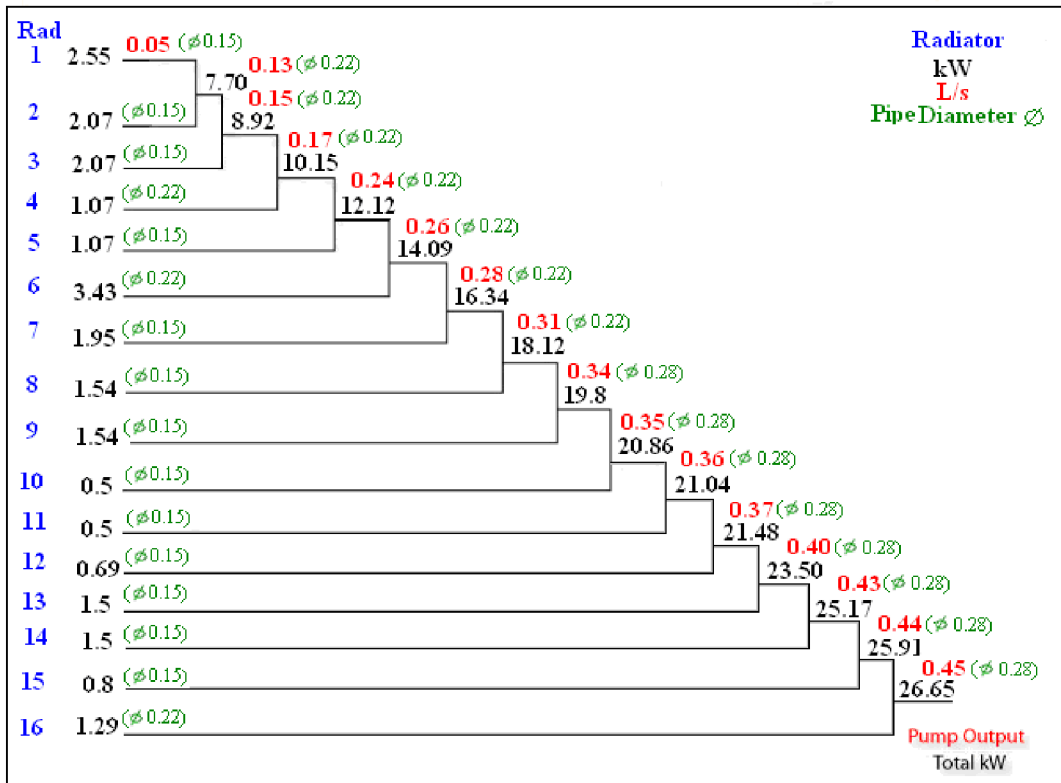

Fig. 11.27 Power flow in the system of large house network

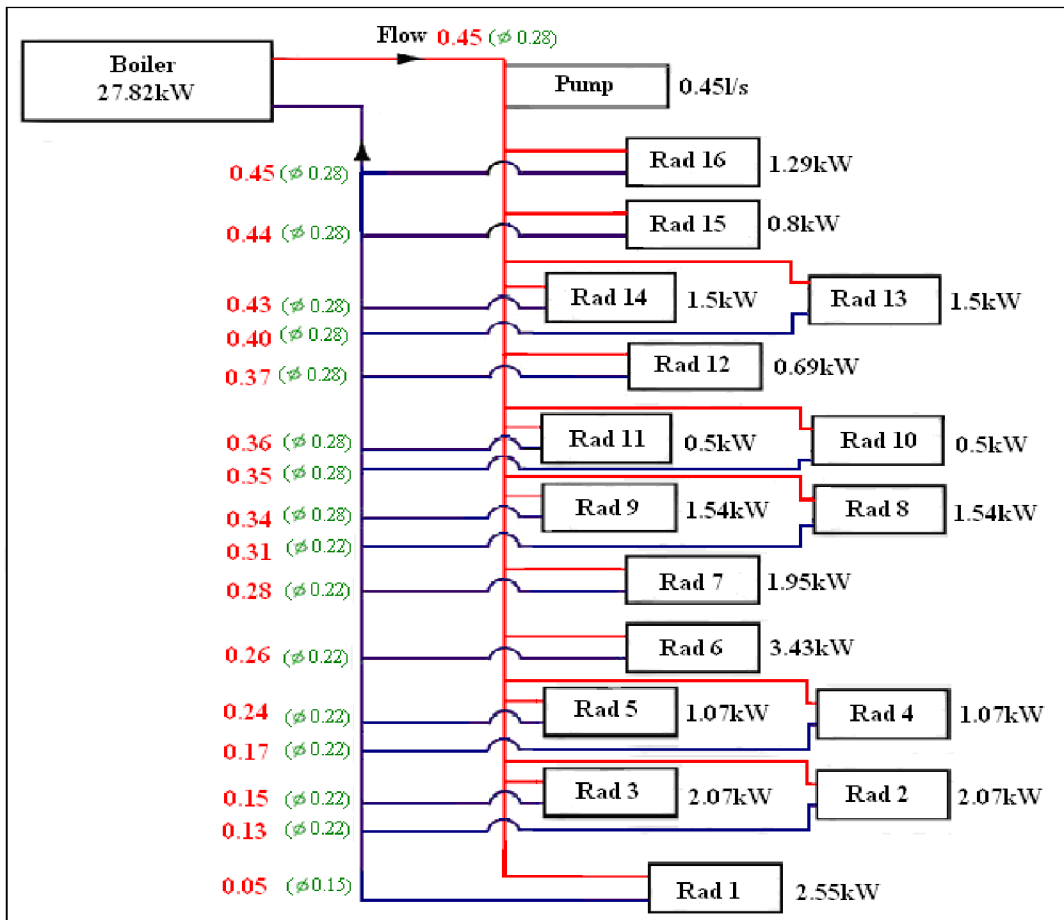

Fig. 11.28 Heating system of large house

Tab. 11.26 Installed power for space heat of large house

No	Room type	L _{nth}	W _{dth}	H _{ght}	Area m ²	Heat loss	Power of radiator Calculated[kW]	Installed Power [kW]
1	Bedroom	5	4	3.2	20	2.3	2.55	2.8
2	Bedroom	5	5	3.2	25	1.86	2.07	2.2
3	Bedroom	4	4	3.2	16	0.96	1.07	1.2
4	Bedroom	4	4	3.2	16	0.96	1.07	1.2
5	Bedroom	5	5	3.2	25	1.86	2.07	2.2
6	Living Room	6	5	3.2	30	3.09	3.43	3.7
7	Living Room	5	4	3.2	20	1.76	1.95	2.1
8	Kitchen	4	4	3.2	16	1.39	1.54	1.7
9	Kitchen	4	4	3.2	16	1.39	1.54	1.7
10	Bath room	3	2	3.2	6	0.45	0.5	0.6
11	Bath room	3	2	3.2	6	0.45	0.5	0.6
12	Bath room	2.5	2	3.2	5	0.62	0.69	0.8
13	Corridor	5.5	4.5	3.2	24.75	1.31	1.5	1.7
14	Corridor	5.5	4.5	3.2	24.75	1.31	1.5	1.7
15	Corridor	5	2	3.2	10	0.37	0.8	0.9
16	Stairs room	5	2	6.6	10	0.8	1.29	1.4
Total					270.5	20.88	24.07	26.5

Then if one supposes a totally new installation power for air conditioning and water heaters, according to the house size, assume for small house two water heaters with (1200 W) for each, and three air conditioners with (1600 W) for each are used. Further assume the for a medium house three water heaters (1200 W), and five air conditioners (1600 W) are used, and for a large house assume four water heaters (1200 W), and seven air conditioners (1600 W). For space heating, the installed power is got from the calculation, using the heat loss calculator [45], see Tab. 11.20, Tab. 11.23, Tab. 11.26

The calculation of the consumption of electric energy during the total period for water heating and air conditioners was calculated as 180 days/ 8 and 7 hours a day respectively, and for space heating the period was calculated as 90 days/ 4 hours a day, the results can be seen in Tab. 11.27 and Fig. 11.29.

$$Consm_{sm\ wh} = 2400W \cdot 8h \cdot 180d / 1000 = 3456kWh$$

$$Consm_{med\ sh} = 21300W \cdot 4h \cdot 90d / 1000 = 7668kWh$$

$$Consm_{lar\ ac} = 9600W \cdot 7h \cdot 180d / 1000 = 12096kWh$$

Where:

$Consm_{sm\ wh}$: Consumption of small sector for water heating

$Consm_{med\ sh}$: Consumption of medium sector for space heating

$Consm_{lar\ ac}$: Consumption of large sector for air conditioning

Tab. 11.27 Supposed of installed power and calculation of total consumption

Segments of consumption	Water Heating				Air Conditioning				Space Heating				Total Consumption [kWh]	
	Installed Power [W]	Daily operation [h]	Daily consumption [kWh]	Consumption for total Period [kWh]	Installed Power [W]	Daily operation [h]	Daily consumption [kWh]	Consumption for total Period [kWh]	Consumption for total Period [RT]	Installed Power [W]	Daily operation [h]	Daily consumption [kWh]		Consumption for total Period [kWh]
Small	2400	8	19.2	3456	4800	7	33.6	6048	1720	15600	4	62.4	5616	15120
Medium	3600	8	28.8	5184	8000	7	56	10080	2866	21300	4	85.2	7668	22932
Large	4800	8	38.4	6912	9600	7	67.2	12096	3439	26500	4	106	9540	28548

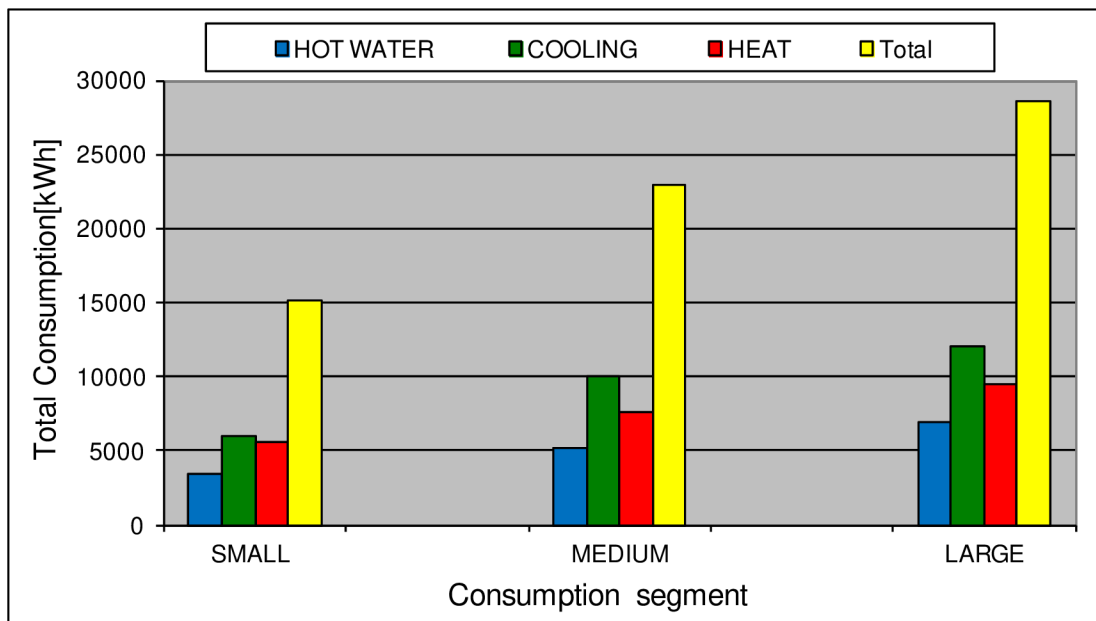
**Fig. 11.29** Total consumption of energy

Then to make economic comparison of the prices of energy needed to cover the necessities for a house, Czech energy prices (5 CZK/kWh and 600 CZK/GJ) are used, since Libyan prices cannot be used, owing to the fact that energy is not yet sold in heat form on the Libyan market. It is clear that when heat energy is used the input will be higher than when electric energy is used.

From the data sheet of heat exchangers, the efficiency will be set at 98% for hot water, and 95% for space heating. For the absorption chiller, using the formula No (9.1), the COP is 0.7 for single stage, and 1.2 for double stage. To make the comparison, the energy must be converted from kilowatt hours to GJ for water heating and space heating, and from kilowatt hours to refrigeration tons for air conditioners; the results can see in Tab. 11.28.

Tab. 11.28 Energy needed when heat energy instead of electric energy is used

Small Consumption						
	Output			Input		
	[kWh]	[RT]	[BUT]	[kWh]	[kJ]	
Water heating	3456		11792362	3527	12695510	12.69
Space heating	5616		19162587	5912	21281684	21.28
Air condition		1720	20636633	8640 5040*	31104000 18144000*	31.10 18.14*
Medium Consumption						
	Output			Input		
	[kWh]	[RT]	[BTU]	[kWh]	[kJ]	
Water heating	5184		17688542	5290	19043265	19.04
Space heating	7668		26164302	8072	29057684	29.06
Air condition	10080	2866	34394388	14400 8400*	51840000 30240000*	51.84 30.24*
Large Consumption						
	Output			Input		
	[kWh]	[RT]	[BTU]	[kWh]	[kJ]	
Water heating	6912		23584723	7053	25391020	25.39
Space heating	9540		32551831	10042	36151579	36.15
Air condition	12096	3439	41273265	17280 10080*	62208000 36288000*	62.21 36.29*

Number with sing *= double stage absorption chiller

Note that when heat energy is used the prices were cheaper than when using electricity even when the input energy amount was higher when heat energy was used to cover the same necessities, the results shown in Tab. 11.29 and Tab. 11.30.

Tab. 11.29 A comparison between the amounts of energy required and difference between the prices

Segments of consumption	Propose of use	Electricity			Heat			
				Cost [CZK]	Single effect		Double effect	
					[GJ]	Cost [CZK]		Cost [CZK]
Small Consumption	Water heating	3456	12.44	17280	12.69	7614	12.69	7614
	Space heating	5616	20.22	28080	21.28	12768	21.28	12768
	Air condition	6048	21.77	30240	31.10	18660	18.14	10884
	Total	15120	54.43	75600	65.07	39042	52.11	31266
Medium Consumption	Water heating	5184	18.66	25920	19.04	11424	19.04	11424
	Space heating	7668	27.60	38340	29.06	17436	29.06	17436
	Air condition	10080	36.29	50400	51.84	31104	30.24	18144
	Total	22932	82.55	114660	99.94	59964	78.34	47004
Large Consumption	Water heating	6912	24.88	34560	25.39	15234	25.39	15234
	Space heating	9540	34.34	47700	36.15	21690	36.15	21690
	Air condition	12096	43.55	60480	62.21	37326	36.29	21774
	Total	28548	102.77	142740	123.75	74250	97.83	58698

To calculate the difference of energy amounts and prices when use of electricity or heat, the amount of electric energy is subtracted from thermal energy, as well for prices, taking into account that for air conditioning, the calculation was with single stage, and double stage absorption chiller with variable of COP.

Tab. 11.30 The amount of thermal energy required, and the difference in prices

		Electric	Heat		Difference	
			Single	Double	Single	Double
Small	Cost [CZK]	75600	39042	31266	36558	44334
	Energy [GJ]	54.43	65.07	52.11	-10.64	2.32
	Energy [kWh]	15120				
Medium	Cost [CZK]	114660	59964	52805	54696	61855
	Energy [GJ]	82.55	99.94	78.34	-17.39	4.21
	Energy [kWh]	22932				
Large	Cost [CZK]	142740	74250	58698	68490	84042
	Energy [GJ]	102.77	123.75	97.83	-20.98.	4.94
	Energy [kWh]	28548				

Through the calculations above, it can be noted that the amount of thermal energy required to cover the same necessities of household consumption, (domestic hot water, space heating, air conditioning) in different seasons of the year was slightly larger in some cases, but nevertheless a drop in prices can also be seen, and the big difference between the prices when using electric power or using thermal energy.

12 SENSITIVITY ANALYSIS

In chapter 11.6, according to the calculation of heat losses for Libyan houses, the results show that heat loss was very high. A comparative analysis of the building using the same building in different places around the world with different temperatures cannot be made. For this reason, an example of a family house from the Czech Republic was used, see Fig. 12.1 and for more details see appendix 2A, 2B, 2C, 2D. Accordingly, heat loss was calculated for that sample [46], then a recalculation of the amount of energy required for heating the house during the heat season and cooling energy for summer season for different places around the world according of latitude and altitude was made.



Fig. 12.1 Family House [46]

All values which have been quoted from the thesis were in accordance with European standard No: ČSN EN 12831 [46]. See Tab. 12.1.

Tab. 12.1 The resulting values of heating demand [46]

Standard		Low-energy house			Family house		
		ČSN 06 0210 I	ČSN 06 0210 II	ČSN EN 12831	ČSN 06 0210 I	ČSN 06 0210 II	ČSN EN 12831
Q_{hl}	W	4254	5280	5421	6845	7723	8587
ε	-	0,8	0,8	0,8	0,8	0,8	0,8
d	Day	232	232	232	232	232	232
t_{im}	°C	19	19	19	18,5	18,5	18,5
t_{em}	°C	4	4	4	4	4	4
HDD	K.Day	3480	3480	3480	3364	3364	3364
t_e	°C	-12	-12	-12	-12	-12	-12
Q_{heat}	MWh. Year	9.17	11.38	11.68	14.50	16.35	18.19

Where : Q_{hl} : Total heat losses

ε : Correction factor corresponding to a single-family house continuous heating operation.

d : Number of days in the heating season

t_{im} : Average indoor temperature in the house

t_{em} : Average outdoor temperature in heating season

HDD: Heat degree days

Q_{heat} : Annual energy consumption for heating house per year

t_e : Design outdoor temperature

$$Q_{heat} = \frac{24 \cdot Q_{hl} \cdot \varepsilon \cdot HDD}{\Delta T} \quad (12.1)$$

Then calculating heat loss for one degree, specific heat loss for one degree will equal:

$$Q_{SH} = Q_{hl} / \Delta T = 8587/30.5 = 281.5 \text{ W/}^\circ\text{C}$$

To calculate energy requirement for heating and cooling by using formula (12.2 & 12.3)

$$\text{For heating} \quad Q_{heat} = 24 \cdot Q_{SH} \cdot \varepsilon \cdot HDD \quad (12.2)$$

$$\text{For cooling} \quad Q_{cool} = 24 \cdot Q_{SH} \cdot \varepsilon \cdot CDD \quad (12.3)$$

By using formula (12.2), (12.3), the recalculation of the energy needed for this family house in different chosen cities according latitude and altitude, and according to heat degree days, and cool degree days for each city, was achieved by using software (*BIZEE SOFTWARE*) [49]. Tab. 12.4 shows the heating and cooling degree days for chosen cities.

There are two main types of degree days: heating degree days (HDD) and cooling degree days (CDD). Both types can be Celsius or Fahrenheit based [47].

- **Heating degree days (HDD)**

Heating degree days (HDD) are used for calculations that relate to the heating of buildings. For example, HDD can be used to normalize the energy consumption of buildings with central heating.

Heating degree-day figures come with a "base temperature", and provide a measure of how much (in degrees), and for how long (in days), the outside temperature was below that base temperature. In the UK, the most readily available heating degree days come with a base temperature of 15.5°C; in the US, it is 65°F [47].

- **Cooling degree days (CDD)**

Cooling degree days (CDD) are used for calculations relating to the cooling of buildings. For example, CDD can be used to normalize the energy consumption of buildings with air conditioning.

Cooling degree-day figures also come with a base temperature, and provide a measure of how much, and for how long, the outside temperature was above that base temperature [47].

- **How degree days are computed**

The calculation requires daily measurements of maximum and minimum outside air Temperature (T_{max} and T_{min}) and a "base temperature" T_{base} , nominated by the user as an estimate

of outside air temperature at which no artificial heating (or cooling) is required. In UK T_{base} for heating has commonly been set at 15.5 °C, but other base temperatures can be adopted [48].

The degree days figure for a given month or week is the accumulated total of daily results over the period in question.

The daily result for heating degree days, D_h , is selected from the following formulae. See Tab. 12.2 using the first one that matches:

Tab. 12.2 Formulae for calculation heating degree days (HDD) [48]

Condition	Formula used
$T_{\text{min}} > T_{\text{base}}$	$D_h = 0$
$(T_{\text{max}} + T_{\text{min}})/2 > T_{\text{base}}$	$D_h = (T_{\text{base}} - T_{\text{min}})/4$
$T_{\text{max}} \geq T_{\text{base}}$	$D_h = (T_{\text{base}} - T_{\text{min}})/2 - (T_{\text{max}} - T_{\text{base}})/4$
$T_{\text{max}} < T_{\text{base}}$	$D_h = T_{\text{base}} - (T_{\text{max}} + T_{\text{min}})/2$

The daily result for cooling degree days D_c , is selected from the following formulae. See Tab. 12.3 using the first one that matches:

Tab. 12.3 Formulae for calculation cooling degree days (CDD) [48]

Condition	Formula used
$T_{\text{min}} < T_{\text{base}}$	$D_c = 0$
$(T_{\text{max}} + T_{\text{min}})/2 < T_{\text{base}}$	$D_c = (T_{\text{max}} - T_{\text{base}})/4$
$T_{\text{max}} \leq T_{\text{base}}$	$D_c = (T_{\text{max}} - T_{\text{base}})/2 - (T_{\text{base}} - T_{\text{min}})/4$
$T_{\text{max}} > T_{\text{base}}$	$D_c = (T_{\text{max}} + T_{\text{min}})/2 - T_{\text{base}}$

12.1 Calculation of energy requirement for chosen cities

By using (*BIZEE SOFTWARE*) [49] to generate the heating degree days (HDD) at T_{base} 15.5°C, and cooling degree days (CDD) with T_{base} at 25°C, the results can see in Tab. 12.4.

Tab. 12.4 Heating degree days (HDD) and Cooling degree days (CDD)

City	HDD			Latitude N°	Altitude/ elevation .m	CDD		
	T _{base} °C	Monthly	Average for 5 years			T _{base} 25 °C	T _{base} 28 °C	T _{base} 30 °C
Libreville. Gabon	15.5	0	0	0°.46	15	571	95	14
Atar. Mauritania	15.5	10	25	20°.52	226	2369	1602	1174
Cairo. Egypt	15.5	169	145	30°.11	75	684	343	193
Tripoli. Libya	15.5	335	441	32°.89	81	678	336	225
Lecce. Italy	15.5	678	910	40°.24	53	283	116	55
Grenoble. France	15.5	2110	2249	45°.36	223	56	16	6
Prague. Czech	15.5	2849	2896	50°.08	365	27	6	2
Moscow. Russia	15.5	3752	3948	55°.59	157	47	17	8
Helsinki. Finland	15.5	3558	3816	60°.25	51	6	0	0
Vadso. Norway	15.5	4679	4990	70°.7	39	0	0	0

Examples of how to calculate heating and cooling energy for Prague and Tripoli by using formula (12.2 & 12.3), the result for chosen cities can see in Tab. 12.5 and Fig. 12.2.

Firstly for Prague

$$\text{Heating Energy: } Q_{\text{heat}} = 24 \cdot 281.5 \cdot 0.8 \cdot 2896 = 15652300.8 \text{ Wh/Y} = 15.654579 \text{ MWh/Y}$$

$$\text{Cooling Energy: } Q_{\text{cool}} = 24 \cdot 281.5 \cdot 0.8 \cdot 27 = 145929.6 \text{ Wh/Y} = 0.145950846 \text{ MWh/Y}$$

Second for Tripoli

$$\text{Heating Energy: } Q_{\text{heat}} = 24 \cdot 281.5 \cdot 0.8 \cdot 441 = 2383516.8 \text{ Wh/Y} = 2.3838638 \text{ MWh/Y}$$

$$\text{Cooling Energy: } Q_{\text{cool}} = 24 \cdot 281.5 \cdot 0.8 \cdot 678 = 3664454.4 \text{ Wh/Y} = 3.664987908 \text{ MWh/Y}$$

Tab. 12.5 Energy needed for heating and cooling

City	Correction Factor	HDD	CDD	Energy needed for Heating MWh/Y	Energy needed for Cooling MWh/Y
		T _{base} 15.5°C	T _{base} 25°C		
Libreville. Gabon	0.8	0		0	3.08
Atar. Mauritania	0.8	10		0.05	12.80
Cairo. Egypt	0.8	145		0.78	3.69
Tripoli. Libya	0.8	441		2.38	3.66
Lecce. Italy	0.8	910		4.29	1.52
Grenoble. France	0.8	2249		12.15	0.30
Prague. Czech	0.8	2896		15.65	0.14
Moscow. Russia	0.8	3948		21.34	0.25
Helsinki. Finland	0.8	3816		20.62	0.03
Vadso. Norway	0.8	4990		26.97	0

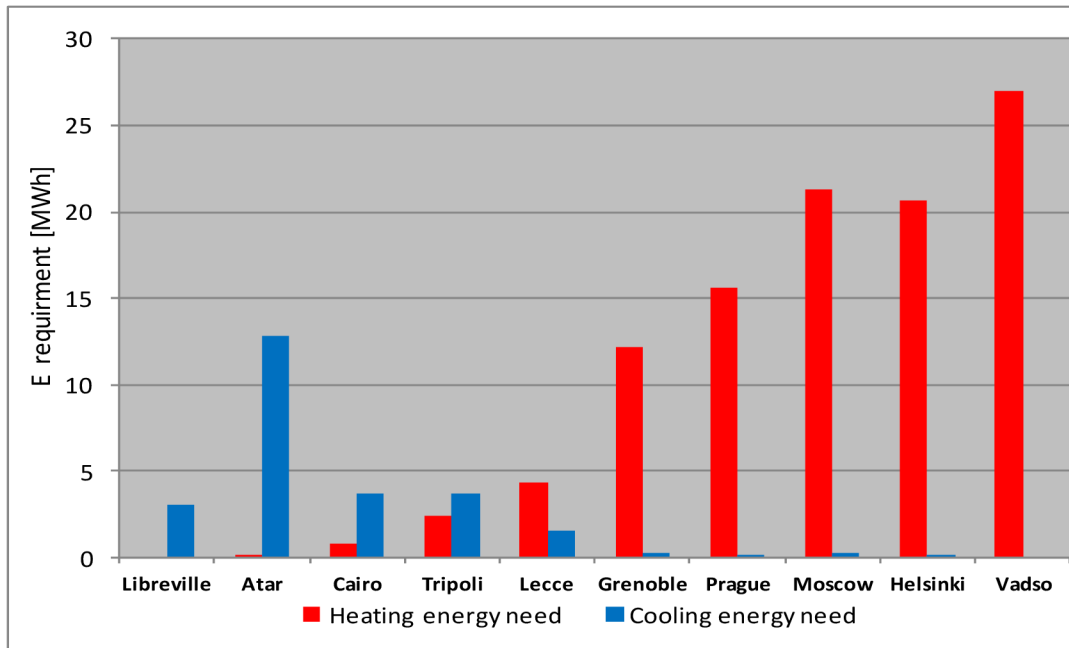

Fig. 12.2 Energy requirement for heating and cooling

Then input energy to cover the necessities when using electric and heat energies is calculated. by using the efficiencies (when use electricity) for water heaters as 98%, for space heaters as 98%, and for air condition EER (Energy Efficiency Ratio) as 10, then when heat energy is used the efficiencies for heat exchanger for water heating as 98%, for space heating as 95%, for absorption chiller COP (Coefficient of performance) as 0.7 for single effect, and 1.2 for double effect. After using formula 9.1 and 9.3 to calculate the energy requirement to cover the same necessities, the results can be seen in Tab. 12.6 and Tab. 12.7, and Fig. 12.3 shows the difference. Taking into account that the assumed time for water heating was six months for African cities, and a year for European cities with same hours, this is why will find in results in Tab. 12.6 , Tab. 12.7 that the quantities of energy for purpose of water heating for African cities is similar, and for European cities is similar.

Tab. 12.6 When using electric energy to cover the necessities

	OUTPUT			INPUT		
	[kWh]	[BTU]	[RT]	[kWh]	[BTU]	[kJ]
LIBREVILLE						
Water heating	3456	12441600		3527	12695510	12033022
Space heating	0	0		0	0	0
Air condition	3087	11111724	878	1053	3791478	3593628
ATAR						
Water heating	3456	12441600		3527	12695510	12033022
Space heating	54	194600.9		55	198572.3	188210
Air condition	12806	46101007	3641	4370	15730317	14909463
CAIRO						
Water heating	3456	12441600		3527	12695510	12033022
Space heating	784	2821716		800	2879302	2729051.8
Air condition	3697	13310717	1051	1262	4541805	4304800.8

TRIPOLI						
Water heating	3456	12441600		3527	12695510	12033022
Space heating	2384	8581910		2433	8757051	8300082.6
Air condition	3665	13193956	1042	1251	4501965	4267039.4
LECCE						
Water heating	6912	24883200		7053	25391020	24066044
Space heating	4297	15470789		4385	15786520	14962734
Air condition	1530	5507212	435	522	1879139	1781080
GRENOBLE						
Water heating	6912	24883200		7053	25391020	24066044
Space heating	12157	43765790		12405	44658970	42328536
Air condition	303	1089766	86	103	371844	352440
PRAGUE						
Water heating	6912	24883200		7053.061	25391020	24066044
Space heating	15655	56356484		15974.06	57506617	54505756
Air condition	146	525423	42	50	179282	169926
MOSCOW						
Water heating	6912	24883200		7053	25391020	24066044
Space heating	21341	76828525		21777	78396454	74305502
Air condition	254	9146253	72	87	312083.1	295798
HELSINKI						
Water heating	6912	24883200		7053	25391020	24066044
Space heating	20628	74259788		21049	75775294	71821121
Air condition	32	116761	9	11	39840	37761
VADSO						
Water heating	6912	24883200		7053	25391020	24066044
Space heating	26974	97105968		27524	99087722	93917040
Air condition	0	0	0	0	0	0

Tab. 12.7 When using heat energy to cover the necessities

	OUTPUT				INPUT		
	[kWh]	[BTU]	[kJ]	[RT]	[kWh]	[BTU]	[kJ]
LIBREVILLE							
Water heat	3456	11792362	12441600		3527	12033022	12695510
Space heat	0	0	0		0	0	0
AirCon Single	3087	10531883	11111724	878	4409	15045547	15873892
Double	3087	10531883	11111724	878	2572	8776569	9259770
ATAR							
Water heat	3456	11792362	12441600		3527	12033022	12695510
Space heat	54	184446	194600.9		57	194153.7	204843.03
AirCon Single	12806	43695324	46101007	3641	18294	62421891	65858582
Double	12806	43695324	46101007	3641	10672	36412770	38417506
CAIRO							
Water heat	3456	11792362	12441600		3527	12033022	12695510
Space heat	784	2674471	2821716		825	2815232	2970227
AirCon Single	3697	12616126	13310717	1051	5282	18023037	19015310
Double	3697	12616126	13310717	1051	3081	10513438	11092264

TRIPOLI							
Water heat	3456	11792362	12441600		3527	12033022	12695510
Space heat	2384	8134081	8581910		2509	8562190	9033589
AirCon Single	3665	12505458	13193956	1042	5236	17864940	18848509
Double	3665	12505458	13193956	1042	3054	10421215	10994964
LECCE							
Water heat	6912	23584723	24883200		7053	24066044	25391020
Space heat	4297	14663479	15470789		4524	15435241	16285041
AirCon Single	1530	5219830	5507212	435	2185	7456900	786744
Double	1530	5219830	5507212	435	1275	4349858	4589343
GRENOBLE							
Water heat	6912	23584723	24883200		7053	24066044	25391020
Space heat	12157	41481966	43765790		12797	43665227	46069253
AirCon Single	303	1032899	1089766	86	432	1475570	1556809
Double	303	1032899	1089766	86	252	860749	908139
PRAGUE							
Water heat	6912	23584723	24883200		7053	24066044	25391020
Space heat	15655	53415641	56356484		16479	56226990	59322615
AirCon Single	146	498005	525423	42	209	711436	750604
Double	146	498005	525423	42	122	415004	437853
MOSCOW							
Water heat	6912	23584723	24883200		7053	24066044	25391020
Space heat	21341	72819392	76828525		22464	76651991	80872132
AirCon Single	254	866898	914625	72	363	1238425	1306607
Double	254	8668978	914625	72	212	722415	762188
HELSINKI							
Water heat	6912	23584723	24883200		7053	24066044	25391020
Space heat	20628	70384699	74259788		21713	74089157	78168198
AirCon Single	32	110668	116761	9	46	158096	166801
Double	32	110668	116761	9	27	92223	97301
VADSO							
Water heat	6912	23584723	24883200		7053	24066044	25391020
Space heat	269734	92038699	97105968		28394	96882841	102216808
AirCon Single	0	0	0	0	0	0	0
Double	0	0	0	0	0	0	0

AirCon Single: Air condition with Single effect. Double: Air condition with Double effect

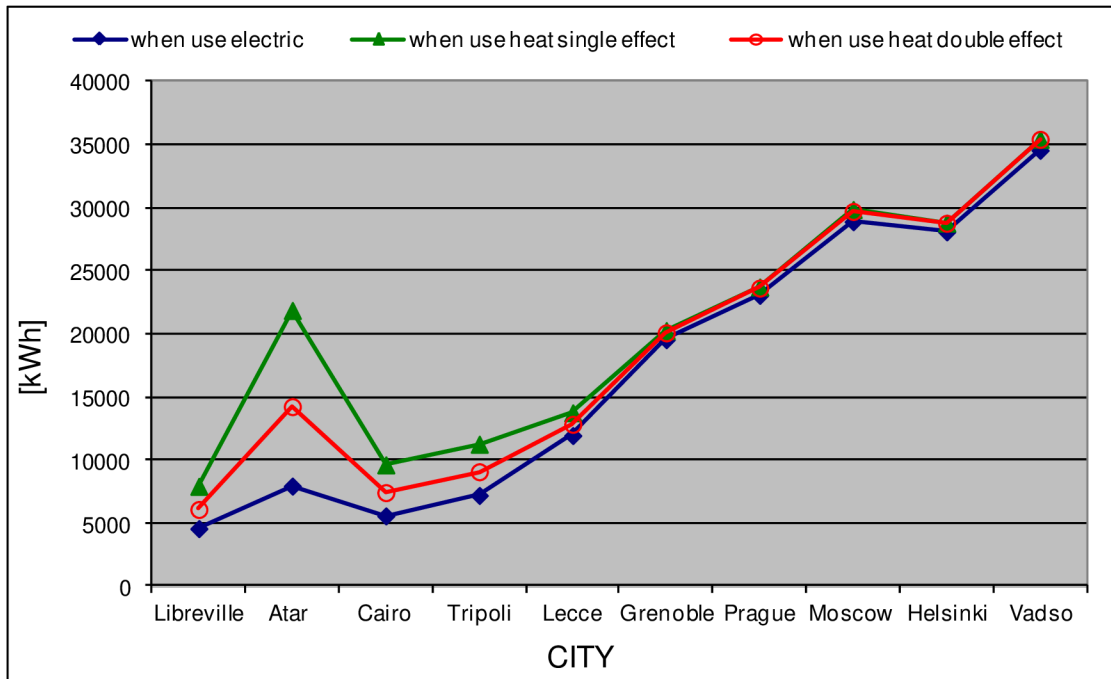

Fig. 12.3 Energy input (requirement) when use electrical & heat (single, double)

The energy prices in Czech currency (CZK) were calculated and the difference between the prices of electric power and thermal energy compared; the results are in Tab. 12.8, and Fig. 12.4 shows that difference.

Tab. 12.8 Total input energy in kWh and GJ and Price of energy in CZK

City	Input Energy			Price [CZK]		
	Electricity [kWh]	Heat [GJ]		Electricity	Heat	
		Single	Double		Single	Double
Libreville	4580	29	22	22899	17142	13173
Atar	7951	79	51	39756	47255	30791
Cairo	5588	35	27	27940	20809	16055
Tripoli	7210	41	33	36048	24347	19634
Lecce	11960	50	46	59801	29726	27759
Grenoble	19562	73	72	97808	43810	43421
Prague	23077	85	85	115385	51279	51091
Moscow	28917	108	107	144583	64542	64215
Helsinki	28113	104	104	140564	62236	62194
Vadso	34577	128	128	172887	76565	76565

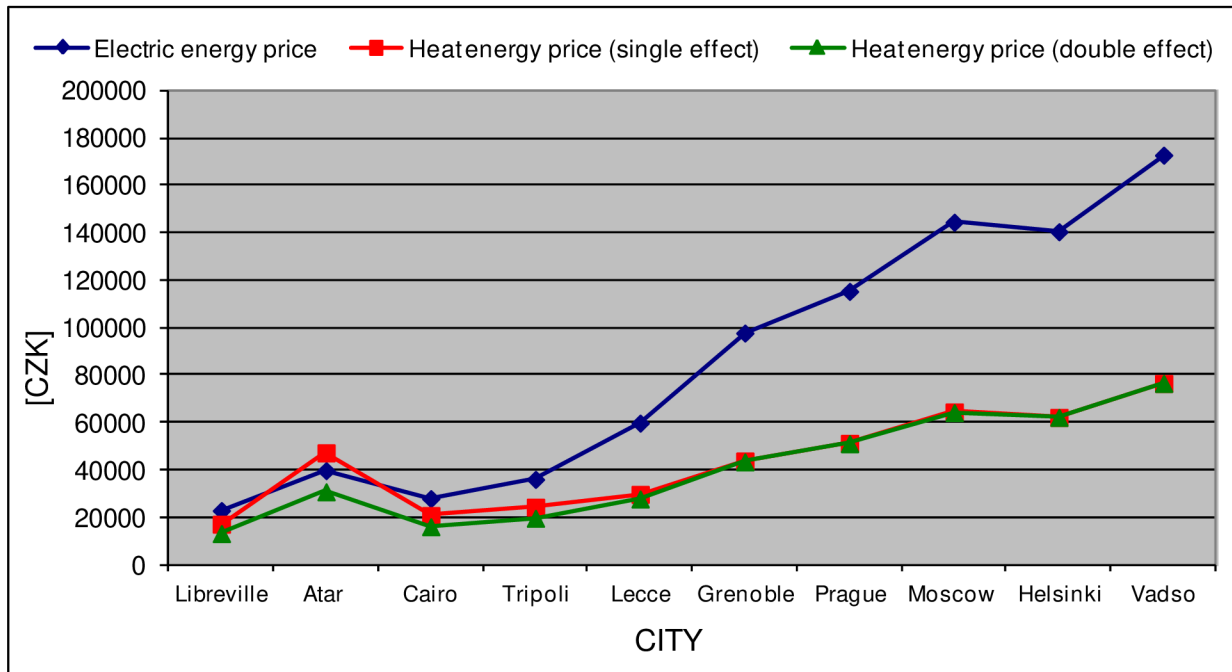

Fig. 12.4 Price in CZK of input energy (electrical & heat with single and double effect)

13 CONCLUSION

This thesis is oriented to an analysis of the possibilities of using cogeneration and tri-generation for improving energy efficiency in countries where these systems are not commonly used. The analysis is made with its focus on the present situation in the energy sector in Libya and in the last part is resized as a simple analysis for chosen places around the world. The second aim of this thesis is to create supporting material for energy authorities in Libya.

The work is divided into three parts. In the first part there is a general summary of energy chain from source to the consumption. Chapters Two and Three explain the general information about power engineering and energy sources in the world of both types, nonrenewable and renewable energies, then in Chapter Four there is clarification of the energy balance in Libya as production of electricity and consumption, and the structure of consumption. In Chapter Five makes an analysis of energy demand in Libya with a forecast of energy needed in future and in Chapter Six the aims of the work are marked out.

The second part deals with explanation of cogeneration and tri-generation principles in context. Chapters Eight and Nine deal with the mean concept of cogeneration and tri-generation with simple examples to explain the advantages of the use of cogeneration and tri-generation units in comparison with traditional power plants. Chapter Ten clarifies the heating distribution network and electric distribution network.

The third part deals with an analysis of the energy situation in Libya and uses these results for preparation of case studies which should show and evaluate properties of using central heating system for covering of basic energy needs - heating, cooling, and hot water.

Chapter Eleven contains a field study of three major Libyan cities (Tripoli, Benghazi, and Sabha) to identify the pattern of consumption in the domestic sector, which is one of the largest sectors of energy consumption in the country. From the analysis, the average consumers were proposed and after comparison of real energy consumption with calculations made with using of average consumers, it was found that not all consumptions in buildings analyzed in the study are driven by electricity and these two values do not corresponding with each other.

The next step was the proposal of three typical houses (small, medium and large) in Libya; for these houses the heat losses were calculated and the heating and cooling system were simply proposed. After that, from the calculation of heat losses of these buildings it was found that it is high and it is not directly comparable with losses of houses placed far away from equator. Then in Chapter Twelve a Czech house was chosen as the sample, and the amount of energy lost in this type of house applied to calculate the specific heat losses for one degree, and to calculate the amount of energy requirement for heating and cooling for many cities, by using heat degree days (HDD), and cooling degree days (CDD). Then the possibility of the implementation of this model of house at a number of different places in the world, according to latitude and altitude above sea level, was assumed and the comparison focused on the difference between the use of electric and thermal energy to operate of such equipment from the technically and economically feasible.

From the results of calculations and comparisons, it is clear that to use of thermal energy associated with the generation of electric power for the purposes of heating and domestic hot water, for air conditioning in the domestic sector as well in industrial processes when needed is more economical than using electricity, and leads to shifting the load from electric load to fuel

load, provides stability in the electrical grid at peak hours, leads to a reduction in the amount of fuel consumption, which in turn reduces quantities of gases emitted as a results of combustion in central power plants, and reduces the power losses in transmission and distribution networks.

By comparing prices for all cases, it was found that the use of heat energy is the lowest prices, except in one case with city of Attar Mauritanian, where it was found in this case the price was higher when using a absorption chiller with single stage for cooling. Except that all prices were lower of all cities, European and African cities in the study, with a note that sometimes the amount of thermal energy required to cover the same necessities is greater than the electrical energy amount; nevertheless the prices are cheaper. The results of this thesis also document that for the final decision about the type of heating/cooling system it is necessary to prepare a case study for a definite place and conditions and also give the summary of aspects which it is necessary to take into consideration.

A proposal for future study is for the use of these data and results in further studies and new comparisons for the use of a cogeneration and tri-generation units in public sectors such as universities, hospitals, airports and other, whichever is greater feasibility of their use in the residential sector or in the public sectors, or a comparison between using cogeneration and tri-generation units with the use of solar energy to cover the same necessities.

In this thesis the only variant taken into account was where the cold is produced locally in each building from heat distributed by a central heating system by absorption chiller. The next variant which should be also researched is central distribution of cold from a central tri-generation unit.

The results of this thesis will be used by concerned authorities as supporting material for development of energy strategy.

REFERENCES

- [1] Power engineering. In: *Wikipedia: the free encyclopedia* [online]. San Francisco (CA): Wikimedia Foundation, 2001-, 2014-01-24 [cit. 2014-02-20]. Available: http://en.wikipedia.org/wiki/Power_engineering
- [2] Electric Power System. In: *Wikipedia: the free encyclopedia* [online]. San Francisco (CA): Wikimedia Foundation, 2001- [cit. 2014-02-23]. Available: http://en.wikipedia.org/wiki/Electric_power_system
- [3] Power engineering. In: *Wikipedia: the free encyclopedia* [online]. San Francisco (CA): Wikimedia Foundation, 2001- [cit. 2014-02-23]. Available: http://wiki.verkata.com/en/wiki/Power_engineering?page=2
- [4] IEA. *Combined Heat and Power: Evaluating the benefits of greater global investment*. France, February 2008, 39 p. Available: http://www.iea.org/media/files/chp/chp_report.pdf
- [5] Electric power distribution. In: *Wikipedia: the free encyclopedia* [online]. San Francisco (CA): Wikimedia Foundation, 2001- [cit. 2014-02-23]. Available: http://en.wikipedia.org/wiki/Electric_power_distribution
- [6] World energy consumption. In: *Wikipedia: the free encyclopedia* [online]. San Francisco (CA): Wikimedia Foundation, 2001- [cit. 2014-02-27]. Available: http://en.wikipedia.org/wiki/World_energy_consumption
- [7] Natural gas. In: *Wikipedia: the free encyclopedia* [online]. San Francisco (CA): Wikimedia Foundation, 2001- [cit. 2013-02-23]. Available: http://en.wikipedia.org/wiki/Natural_gas
- [8] TRAN, Jany. *Energy in a Cubic Meter of Natural Gas* [online]. 2002 [cit. 27-2-2014]. Available: <http://hypertextbook.com/facts/2002/JanyTran.shtml>
- [9] Coal. In: *Wikipedia: the free encyclopedia* [online]. San Francisco (CA): Wikimedia Foundation, 2001- [cit. 2014-02-23]. Available: <http://en.wikipedia.org/wiki/Coal>
- [10] Sources of Electricity. ENTERPRISE FOR EDUCATION. *Sources of Electricity* [online]. Santa Monica, CA 90401, 2011, 2011-09-06 [cit. 2014-02-20]. Available: http://www.enterpriseforeducation.com/sourcesofelectricityresources.html#anchor_158
- [11] EKHLAT, M, M SALAH IBRAHIM and N. M. KREAMA. *Mediterranean and National Strategies for Sustainable Development: Energy Efficiency and Renewable Energy Libya - National study* [pdf]. February 2007, 45p [cit. 25-2-2014]. Available: http://planbleu.org/sites/default/files/upload/files/LI_NationalStudy_final.pdf
- [12] GENERAL ELECTRIC COMPANY OF LIBYA (GECOL). *ANNUAL REPORTS (2002-2009)*. Available: <http://www.gecol.ly/aspx/Statistics.aspx>
- [13] *Provision of Technical Support/Services for an Economical, Technological and Environmental Impact Assessment of National Regulations and Incentives for Renewable Energy and Energy Efficiency: Country Report Libya*. December 2009, revised April 2010, 133p. Available: http://www.rcreee.org/sites/default/files/rcreee_rs_countryreport_libya_en_2009.pdf
- [14] IBRAHIM M., SALEH. *PROSPECTS OF RENEWABLE ENERGY IN LIBYA* [online]. February 2007 [cit. 2014-02-24]. Available: <http://www.irsol.ch/spse/spse-download.php?pid=20>
- [15] EL-ARROUDI, K, M MOKTAR, B EL-OBADI, S SANOGA and S OSMAN. GENERAL ELECTRIC COMPANY OF LIBYA. (GECOL). *Demand Side Management in Libya - A Case Study of the General Electric Company of Libya: Transmission System Operation and Control Department*. 2009, 23p. Available: http://www.steg.com.tn/dwl/Dr_Khalil_libye.pdf
- [16] GENERAL ELECTRIC COMPANY OF LIBYA. *Planning Electrical Power System Studies for Libya: Demand Forecasting & Generation Expansion Planning Until 2025. Final report*. September 2008. (KEPCO).
- [17] Thermal power station: Boiler and steam cycle. In: *Wikipedia: the free encyclopedia* [online]. San Francisco (CA): Wikimedia Foundation, 2001- [cit. 2014-02-23]. Available: http://en.wikipedia.org/wiki/Thermal_power_station#Boiler_and_steam_cycle
- [18] ÖZGİRGİN, EKİN. *Utilization of Natural Gas, Optimization of Cogeneration/Combined Cycle Applications in Campus Environment*. May 2004. Available: <http://etd.lib.metu.edu.tr/upload/12604986/index.pdf>. M.Sc. THE MIDDLE EAST TECHNICAL UNIVERSITY. Supervisor O. Cahit Eralp
- [19] ÇOLPAN, Can Özgür. *EXERGY ANALYSIS OF COMBINED CYCLE COGENERATION SYSTEMS*. MAY 2005. Available: <http://www.colpan.org/publications/thesis/MSc.pdf>. M.Sc. MIDDLE EAST TECHNICAL UNIVERSITY. Supervisor Prof. Dr. Tulay Yesin.
- [20] ENERGY TECHNOLOGY FACT SHEET: Cogeneration. 2 p. Available: <http://gossengineering.com/articles/unep-fact-sheet-on-cogeneration-chp.pdf>
- [21] *Cogeneration/Combined Heat and Power (CHP)*. March 2011, 15 p. Available: <http://www.c2es.org/docUploads/CogenerationCHP.pdf>
- [22] DEVKI ENERGY CONSULTANCY PVT. LTD. *COGENERATION*. 2006, 76 p. Available: <http://www.energymanagertraining.com/CodesandManualsCD-5Dec%2006/BEST%20PRACTICE%20MANUAL-COGENERATION.pdf>

- [23] THE EC-ASEAN BUSINESS FACILITATOR. *Technical Report Available Cogeneration Technologies in Europe: Part I Definitions and Systems* [online]. December 2003 [cit. 22-8-2013]. Available: <http://www.cogen3.net/techreportform.html>
- [24] SHEHATA, Mohammed. The Auspices of Tri-generation in the Data Centre: As the world strives towards efficient and renewable energy sources, the focus on data centres and their energy usage has been more prominent [pdf]. 4 p [cit. 27-2-2014]. Available: <http://ptsconsulting.com/user-content/documents/Articles/PTS%20Perspective%20-%20Trigeneration%20In%20DCs.pdf>
- [25] UNITED NATIONS ECONOMIC AND SOCIAL COMMISSION FOR ASIA AND THE PACIFIC: ENVIRONMENT AND DEVELOPMENT DIVISION. *Guidebook on Cogeneration as a Means of Pollution Control and Energy Efficiency in Asia: State of Art Review of Cogeneration*. Bangkok, Thailand, 2000. Available: <http://www.unescap.org/esd/publications/energy/Co-gen/part1ch2.pdf>
- [26] EUROPEAN COMMISSION DIRECTORATE-GENERAL FOR ENERGY SAVE II PROGRAMME. *Energy Savings by CHCP plants in the Hotel Sector: Absorption chillers* [online]. May 2001, 12 p. [cit. 18-5-2012]. Available: http://www.inescc.pt/urepe/chose/reports/B-absorption_chillers.pdf
- [27] WU, D.W. a R.Z. WANG. 2006 ELSEVIER LTD. Combined cooling, heating and power: A review. 21 August 2006, 37p. Available: <http://www.sjtuir.sjtu.edu.cn/news/2006-Combined%20cooling,%20heating%20and%20power-%20A%20review.pdf>
- [28] DEPARTMENT OF ENERGY & CLIMATE CHANGE. Technology > Absorption Cooling > Absorption Cooling & CHP: Absorption Cooling & CHP. Available: <http://chp.decc.gov.uk/cms/absorption-cooling-chp/>
- [29] THE ENGINEERING TOOL BOX. *Calculating Cooling Loads: Calculating chiller and cooling tower refrigeration in tons*. Available: http://www.engineeringtoolbox.com/cooling-loads-d_665.html
- [30] GRONDZIK, WALTER and RICHARD FURST. *HVAC COMPONENTS AND SYSTEMS*. 72 p. Available: http://arch.ced.berkeley.edu/vitalsigns/res/downloads/rp/hvac/hvac-sml_opt.pdf
- [31] *Chiller, Boiler, and Distribution System Control Applications: DISTRICT HEATING APPLICATIONS* [online]. [cit. 24-2-2013]. Available: <http://www.buildingcontrolworkbench.com/Portals/1/GrayBook/Gcbddha.htm>
- [32] SKAGESTAD, Bard and Peter MILDENSTEIN. *Programme of Research, Development and Demonstration on District Heating and Cooling: District Heating and Cooling Connection Handbook* [online]. p. 86 [cit. 2014-02-24]. Available: <http://www.districtenergy.org/assets/CDEA/Best-Practice/IEA-District-Heating-and-Cooling-Connection-Handbook.pdf>
- [33] IEA-ETSAP AND IRENA. *Thermal Energy Storage: Technology Brief*. January 2013, 24 p. Available: <https://www.irena.org/DocumentDownloads/Publications/IRENA-ETSAP%20Tech%20Brief%20E17%20Thermal%20Energy%20Storage.pdf>
- [34] SHARMA, Atul, V.V. TYAGI, C.R. CHEN and D. BUDDHI. ELSEVIER LTD. *Renewable and Sustainable Energy Reviews 13 (2009) 318–345: Review on thermal energy storage with phase change materials and applications*. 2009, 28 p. Available: http://www.researchgate.net/publication/222427268_Review_on_thermal_energy_storage_with_phase_change_materials_and_applications
- [35] Electric power transmission. In: *Wikipedia: the free encyclopedia* [online]. San Francisco (CA): Wikimedia Foundation, 2001- [cit. 2014-02-23]. Available: http://en.wikipedia.org/wiki/Electric_power_transmission
- [36] Electrical Notes & Articles: Total Losses in Power Distribution and Transmission Lines-Part2. Available: <http://electricalnotes.wordpress.com/2013/07/01/total-losses-in-power-distribution-transmission-lines-part-1/>
- [37] Electrical Notes & Articles: Total Losses in Power Distribution and Transmission Lines-Part 2. Available: <http://electricalnotes.wordpress.com/2013/07/02/total-losses-in-power-distribution-transmission-lines-part-2/>
- [38] KSHOUT Fwzi, Ali MILAD and Younis MANSOUR. GENERAL ELECTRIC COMPANY OF LIBYA. *The final report for the study of energy consumption in the domestic sector*. 2010, 16p.
- [39] OVERVIEW OF COGENERATION AND ITS STATUS IN ASIA: *Trigeneration and Vapour Absorption Cooling* [pdf]. p.19-20 [cit. 18.5.2011]. Available: http://www.fire-italia.it/forum/cogenerazione/UNESCO-CHP_Asia.pdf
- [40] *COPs, EERs, and SEERs: How Efficient is Your Air Conditioning System?.* Available: <http://www.powerknot.com/how-efficient-is-your-air-conditioning-system.html>
- [41] *Types of Heat Exchangers* [online]. [cit. 24-2-2014]. Available: <http://www.thomasnet.com/articles/process-equipment/heat-exchanger-types>
- [42] SKAGESTAD, Bard a Peter MILDENSTEIN. *Programme of Research, Development and Demonstration District Heating and Cooling: District Heating and Cooling Connection Handbook*. [online]. 86p [cit. 2014-05-01]. Available: <http://www.districtenergy.org/assets/CDEA/Best-Practice/IEA-District-Heating-and-Cooling-Connection-Handbook.pdf>
- [43] ITT LOWARA. *Pumps and pipes in theory and practice: The anatomy of a comfortable and cost-efficient indoor climate* [pdf]. 20 p [cit. 8-1-2014]. Available: http://www.ilpa.com.tr/pdf/dokumanlar/pumps_pipes_theory.pdf
- [44] CHP GROUP CIBCE. *Absorption Cooling: DATASHEET 07* [online]. FEB 2012, 3p [cit. 20.11.2013]. Available: <http://www.flexiblespace.com/wp-content/uploads/2012/07/Datasheet-7-Absorption-Cooling.pdf>

- [45] *Heat Loss Calculators* [online]. Available: http://www.plumbers-central-london.co.uk/calculator_tool.php#stop_here
- [46] ELCNER, JAKUB. *Comparison of heat losses calculation by CSN 06 0210 and CSN EN 12831*. 2008. Available: http://www.vutbr.cz/www_base/zav_prace_soubor_verejne.php?file_id=5958. Master's thesis. BRNO UNIVERSITY OF TECHNOLOGY. Supervisor Ing. JAN KOSNER, Ph.D.
- [47] Energy Management / Energy Monitoring and Targeting Articles: Degree Days - Handle with Care. Available: <http://www.energylens.com/articles/degree-days#normalization>
- [48] DEGREE DAYS DIRECT LIMITED. *Degree Day Data: How degree days are computed* [online]. [cit. 15.2.2014]. Available: <http://www.vesma.com/ddd/ddcalcs.htm>
- [49] BIZEE SOFTWARE. Available: <http://www.degreedays.net/>
- [50] AL-JADI, I. M. Saleh Ibrahim, M. A. EKHLAT and N. M. KREMA. *PHOTOVOLTAIC IN LIBYA APPLICATIONS, AND EVALUATION*. The International Conference on Renewable Energy for Developing Countries-20. Available: <http://www.udc.edu/docs/cere/PHOTOVOLTAIC%20IN%20LIBYA.pdf>
- [51] KNIGHT, Ian a Ismet UGURSAL. INTERNATIONAL ENERGY AGENCY. *Residential Cogeneration Systems: A Review of The Current Technologies: The Simulation of Building-Integrated Fuel Cell and Other Cogeneration Systems* [pdf]. April 2005, 93p [cit. 2.5.2014]. Available: http://www.ecbcs.org/docs/Annex_42_Review_Residential_Cogen_Technologies.pdf
- [52] Seasonal energy efficiency ratio. In: *Wikipedia: the free encyclopedia* [online]. San Francisco (CA): Wikimedia Foundation, 2001- [cit. 2014-02-23]. Available: http://en.wikipedia.org/wiki/Seasonal_energy_efficiency_ratio
- [53] INDUSTRIAL TECHNOLOGIES PROGRAM ENERGY EFFICIENCY AND RENEWABLE ENERGY U.S. DEPARTMENT OF ENERGY. *Use Low-Grade Waste Steam to Power Absorption Chillers*. January 2006, 2p. Available: <http://www.nrel.gov/docs/fy06osti/39316.pdf>
- [54] STUDYMODE. *Energy Efficient Ratio* [online]. Feb 2013 [cit. 20.8.2013]. Available: <http://www.studymode.com/essays/Energy-Efficient-Ratio-Eer-1456685.html>
- [55] A, ALMABROK. *Cogeneration and Trigeration*. Poznan University of Technology, April 11-13, 2011. p 79-80. ISBN 978-83-89333-39- 1.
- [56] A, ALMABROK, BARTOŠÍK T, VÁVRA J and TOMAN P. *Possibilities of Installing Photovoltaic Power Plant in Southern Region in Libya*. Brno University of Technology, 2012. p 543-547. ISBN 978-80-214-4514-7.
- [57] A, ALMABROK. *UTILIZATION OF SOLAR ENERGY IN LIBYA*. Poznan University of Technology, April 11-13, 2011. p 105-106. ISBN 978-83-89333-39-1.
- [58] CARDONA, E., A. PIACENTINO a F. CARDONA. *Applied Thermal Engineering: Energy saving in airports by trigeneration. Part I: Assessing economic and technical potential*. [online]. 2006. Volume 26, Issue 14-15, 10 p. 1427-1436 [cit. 2014-02-25]. Available: <http://dx.doi.org/10.1016/j.applthermaleng.2006.01.019>
- [59] DENG, J., R.Z. WANG and G.Y. HAN. *Progress in Energy and Combustion Science: A review of thermally activated cooling technologies for combined cooling, heating and power systems*. April 2011, 32p. 172-203. Available: <http://www.sciencedirect.com/science/article/pii/S0360128510000493#>
- [60] *Coal Fired Thermal Power Plant: The Basic Steps and Facts* [online]. [cit. 20.1.2012]. Available: http://www.brighthubengineering.com/power-plants/18082-coal-fired-thermal-power-plant-the-basic-steps-and-facts/#imgn_0
- [61] *Boilers and central heating* [online]. [cit. 24-2-2014]. Available: <http://davidkearns.co.uk/boilers.php>
- [62] *Residential Cogeneration Systems: A Review of The Current Technologies*. April 2005, 93 p. ISBN 0-662-40482-3. Available: http://www.ecbcs.org/docs/Annex_42_Review_Residential_Cogen_Technologie
- [63] *Absorption Cooling* [online]. [cit. 25-2-2014]. Available: <http://chp.decc.gov.uk/cms/absorption-cooling/>
- [64] *Absorption Cooling & CHP* [online]. [cit. 25-2-2014]. Available: <http://chp.decc.gov.uk/cms/absorption-cooling-chp>
- [65] *Boilers and central heating* [online]. [cit. 24-2-2014]. Available: <http://davidkearns.co.uk/boilers.php>
- [66] CARDONA, E and A PIACENTINO. *Energy and Buildings: A measurement methodology for monitoring a CHCP pilot plant for an office building*. [online]. October 2003. Volume 35. Issue 9, p 919–925 [cit. 2014-02-25]. Available: [http://dx.doi.org/10.1016/S0378-7788\(03\)00021-5](http://dx.doi.org/10.1016/S0378-7788(03)00021-5)
- [67] *Energy Scenario for Achieving Sustainability in Indian Situations*. Delhi, India, roč. 6. ISSN 0974 - 3154. Available: http://www.ripublication.com/irph/ijert_spl/ijertv6n6spl_13.pdf
- [68] A, ALMABROK. Poznan University of Technology academic journals. *Electrical engineering: Comparison between cogeneration and separate production of heat and electricity*. Poznan University of Technology, 2012, Issue 70. p167-172. ISSN 1897- 0737
- [69] SAN MARTÍN, J.I., I. ZAMORA, J.J SAN MARTÍN, V. APERRIBAY and P. EGUÍA. *Trigeneration Systems with Fuel Cells* [online]. 6 p. [cit. 24-2-2014]. Available: <http://www.icrepq.com/icrepq-08/245-san-martin.pdf>
- [70] JIN CHO, Hee. *DYNAMIC SIMULATION AND OPTIMAL REAL-TIME OPERATION OF CHP SYSTEMS FOR BUILDINGS*. Mississippi State, Mississippi, May 2009. Ph.D. Mississippi State University. Supervisor Rogelio Luck.

-
- [71] Thomas, J. and Tracy JR. *Design, Modeling, Construction, and Flow Splitting Optimization of a Micro Combined Heating, Cooling, and Power System* [online]. 22-6-2010 [cit. 2014-02-26]. Available: <http://diginole.lib.fsu.edu/cgi/viewcontent.cgi?article=4880&context=etd>. M.Sc. THE FLORIDA STATE UNIVERSITY. Supervisor Juan C. Ordonez.
- [72] R.ZAROUG, Mohamed. *Renewable Energy in Libya (The Future Prospectives)*. Amman, Jordan, March 2012. Available: <http://www.slideserve.com/cheung/renewable-energy-in-libya-the-future-prospectives>
- [73] IEA. *Renewable Energy Essentials: Hydropower* [pdf]. March.2010, 4p. Available: http://www.iea.org/publications/freepublications/publication/Hydropower_Essentials.pdf