



VYSOKÉ UČENÍ TECHNICKÉ V BRNĚ

BRNO UNIVERSITY OF TECHNOLOGY

FAKULTA STROJNÍHO INŽENÝRSTVÍ

FACULTY OF MECHANICAL ENGINEERING

ÚSTAV AUTOMOBILNÍHO A DOPRAVNÍHO INŽENÝRSTVÍ

INSTITUTE OF AUTOMOTIVE ENGINEERING

ZVYŠOVÁNÍ EFEKTIVITY ZÁŽEHOVÉHO MOTORU POMOCÍ VODNÍHO VSTŘIKOVÁNÍ

INCREASING EFFICIENCY OF GASOLINE ENGINES BY WATER INJECTION

BAKALÁŘSKÁ PRÁCE

BACHELOR'S THESIS

AUTOR PRÁCE

AUTHOR

Miroslav Benka

VEDOUCÍ PRÁCE

SUPERVISOR

Ing. Jiří Bazala

BRNO 2018

Zadání bakalářské práce

Ústav: Ústav automobilního a dopravního inženýrství
Student: **Miroslav Benka**
Studijní program: Strojírenství
Studijní obor: Stavba strojů a zařízení
Vedoucí práce: **Ing. Jiří Bazala**
Akademický rok: 2017/18

Ředitel ústavu Vám v souladu se zákonem č. 111/1998 o vysokých školách a se Studijním a zkušebním řádem VUT v Brně určuje následující téma bakalářské práce:

Zvyšování efektivity zážehového motoru pomocí vodního vstřikování

Stručná charakteristika problematiky úkolu:

Zvyšování účinnosti spalovacích motorů je neustálý trend a vodní vstřikování se jeví jako moderní technologie, jak dále posunout nejen účinnost, ale jak také snížit emise zážehového motoru.

Student provede rešerši stávajících systémů a zhodnotí je. Práce bude obsahovat vytvoření modelu systému vstřikování vody pro zážehový motor. Student provede vyhodnocení přínosu tohoto systému.

Cíle bakalářské práce:

Historický vývoj vodního vstřikování.

Teorie a princip vodního vstřikování, vliv na spotřebu a emise.

Představení stávajících systémů a jejich zhodnocení.

Vliv vodního vstřikování na parametry motoru (model).

Vyhodnocení a výhled do budoucna.

Práce bude v anglickém jazyce.

Seznam doporučené literatury:

STONE, Richard. Introduction to internal combustion engines. 3rd edition. Warrendale, Pa.: Society of Automotive Engineers, 1999. 641 s. ISBN 0768004950.

Termín odevzdání bakalářské práce je stanoven časovým plánem akademického roku 2017/18.

V Brně, dne 23. 10. 2017



prof. Ing. Václav Píštěk, DrSc.
ředitel ústavu

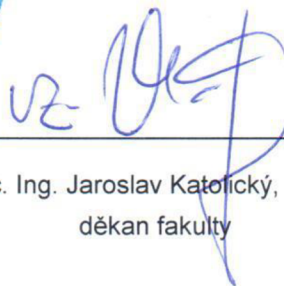

doc. Ing. Jaroslav Katoňický, Ph.D.
děkan fakulty

ABSTRACT

This thesis is focused on water injection technology to increase the efficiency of a gasoline spark ignition engine. It provides a brief overview of the historical development of technology, current research, and in the end it deals with the practical modeling of the water injection system in GT-POWER.

KEYWORDS

Water injection, anti-detonant injection, increasing efficiency, lower emissions, engine knocking

BIBLIOGRAPHIC QUOTATION

Benka, M. *Increasing efficiency of gasoline engines by water injection*. Brno, 2018. Bachelor Thesis. Brno University of Technology, Faculty of Mechanical Engineering, Institute of Automotive Engineering. 39 s. Supervisor Jiří Bazala.



AFFIDAVIT

I declare that this work is my original work, I worked it separately under the direction of Jiří Bazala and using the literature listed at the end of this thesis.

In Brno 23rd of May 2018

.....

Miroslav Benka

THANKS

I would like to thank my supervisor Jiří Bazala for valuable advice, direct leadership and willingness to show the direction to be taken. I also want to thank to my classmate and friend Juraj Pospíšil for helping me with the GT-POWER program.

CONTENTS

Introduction	9
1 History of water injection	10
1.1 History of engines	10
1.2 Water injection as a boost in airplanes	11
1.3 First use in mass produced car	12
2 Theory of water injection	16
2.1 Principle of operation.....	17
2.2 Decrease in temperature.....	18
2.3 Present technology and future.....	22
3 Water injection simulation.....	24
3.1 Port water injection	25
3.2 Direct water injection.....	29
3.3 Discussion	32
Conclusion	35
List of abbreviations and symbols used.....	39

INTRODUCTION

People are very creative creatures. From the beginning of our civilization, people are inventing and renewing other inventions to improve their lives and lives of other people. In modern history we have learned to change any kind of energy to mechanical. The most common ways are to use chemical energy to mechanical directly or through electrical energy to mechanical. The direct way to transfer energy from chemical to mechanical is to release energy by enlarging heat and afterwards changing it to some kind of move. Speaking of automotive engines, we change chemical energy into rotary movement. I will write about gasoline engines, where I focus on improving the outcome and decreasing exhaust toxins by injecting water into combustion chamber. Firstly I will bring brief summary of history of engines itself and history of water injection. In chapter 2 I will deal with the principle of water injection. An essential part of the chapter is the exploration of available sources of literature as well as sources from the internet, such as impact on fuel consumption, performance of the engine and emission production by using a water injection. Chapter 3 is a vision where the reader will offer our insight into the issues we are examining in the future. In this bachelor thesis, I will use the method of literary research to deal with the issue of water injection with respect to the less economical operation of engines, which tends to contribute in this way also to savings and protection of the environment.

1 HISTORY OF WATER INJECTION

1.1 HISTORY OF ENGINES

Since the first engine was constructed, it has come through a numerous years of invention. Very first and succesful at the same time construction of internal combustion engine was made by a Belgian inventor Jean-Joseph-Étienne Lenoir in 1858. He constructed a two-stroke and double-acting engine which run a mixture of coal gas and air. This was very invetional for such time, frequently used in France and Britain for low-power work such as printing and pumping. The big insufficiency was only 4% fuel efficiency. In 1865 he adjusted his engine to run on liquid fuel and with a “vehicle” which was powered by this engine he took a 10 kilometre long way. Lenoir wasn’t the only one to experiment with liquid fuel, in 1864 Siegfried Marcus, an Austrian engineer, built a gasoline powered engine and several years later he attached this engine to a vehicle and the result was a 10 mph running vehicle. In 1876 Nicolaus August Otto and Eugen Laugen built a four-stroke engine, using a Alphonse Beau de Rochas ‘s patent from 1864, which caused a revoke of Otto’s patent in 1886 after the original was brought to light. Regardless to that, because there were produced more than 30 000 units of Otto’s engine, it is commonly known as Otto cycle (Figure 1). [2][3][5] It is specific process inside the combustion chamber:

- first stroke – [Intake stroke] intake of mixture of gasoline mist and air into chamber while the piston move downwards and enlarge the chamber,
- second stroke – [Compression stroke] moving upwards and lessening a chamber causes a mixture to compress, when piston is in the top dead center, spark is inducted and the mixture starts to burn,
- third stroke – [Power/Combustion stroke] burning gases are expanding its volume and the pressure press the piston to lower dead end,
- fourth stroke – [Exhaust stroke] when the piston reaches the lower dead end, exhaust valve opens and while piston is coming to top dead center it press combustion product out of chamber.[4]

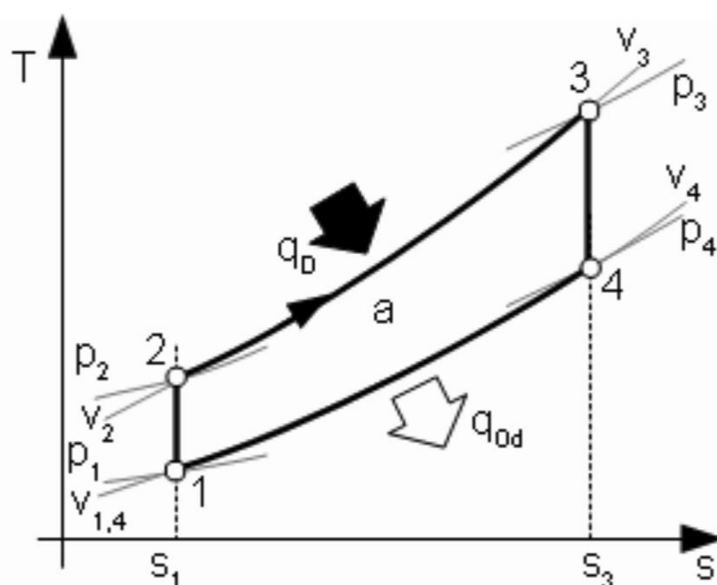

Figure 1 T-s diagram of so-called Otto's cycle [20]

For the first “modern” gasoline engine is considered to be the Daimler’s one cylinder 4-stroke engine. Construction was very simple where fuel was injected through a carburetor to the vertical cylinder. With Wilhelm Maybach they invented the Nicolaus Otto’s internal combustion engine. In 1889 they brought a new product, a two-cylinder four-stroke V-slanted engine with mushroom shaped valves and the same year they have attached it to their first vehicle which was able of speed of 10 mph. [5]

Another succesful automobile manufactures were Rene Panhard and Emile Levassor, French partners in a woodworking machinery. After decision to start automobile manufacturing they made their first car in 1890, where the Daimler’s engine was used. The production was commissioned by Edouardo Sarazin, the holder of the Daimler’s patent for French market. Different and inovative with Panhard and Levassor cars was putting the engine in the front of vehicle while the torque was transferred to the rear wheel, which made a new standard for other manufactures. They also improved a transmission leading to a change-speed gearbox and a front radiator. These all design changes were known as the System Panhard.

1.2 WATER INJECTION AS A BOOST IN AIRPLANES

Every manufacturer has tried to improve their engines. In the past century the tetraethyl lead was added to a gasoline to eliminate engine knocking or pinging. Tetraethyl lead is a toxic colorless oily liquid, synthetically made, also called an antiknock gasoline additive. Adding it to a gasoline reduces it’s combusability. [6] In early 20th century, a ethanol was used to lower the inefficiency of aircraft engines instead of methanol which is capable to ouput more power. This was because methanol, mixed or straight, is more corrosive than ethanol, and has more handling problems and dangers. Sir Harry Ricardo brought in late 1920’s the idea of injecting water into combustion chamber, claiming it was the best anti-detonant. Mixing methanol with water solved these issues and with squishband combustion chamber (Figure 2) were able to increase compression ratio in about 50% and significantly lower fuel consumption. [16] The system was used in the Messerschmitt BF-109. Through targeted injection of water / methanol, the performance of these aircraft increased by approximately 550 PS. Beginning with the G6 series, the DB 605 D engine with 1140 kW at a full pressure altitude of 6,650 m was installed. The installed MW50 (water / methanol) injection system has enabled the pilot to increase the engine power of the aircraft by approximately 40% during the take-off and climb. [9]

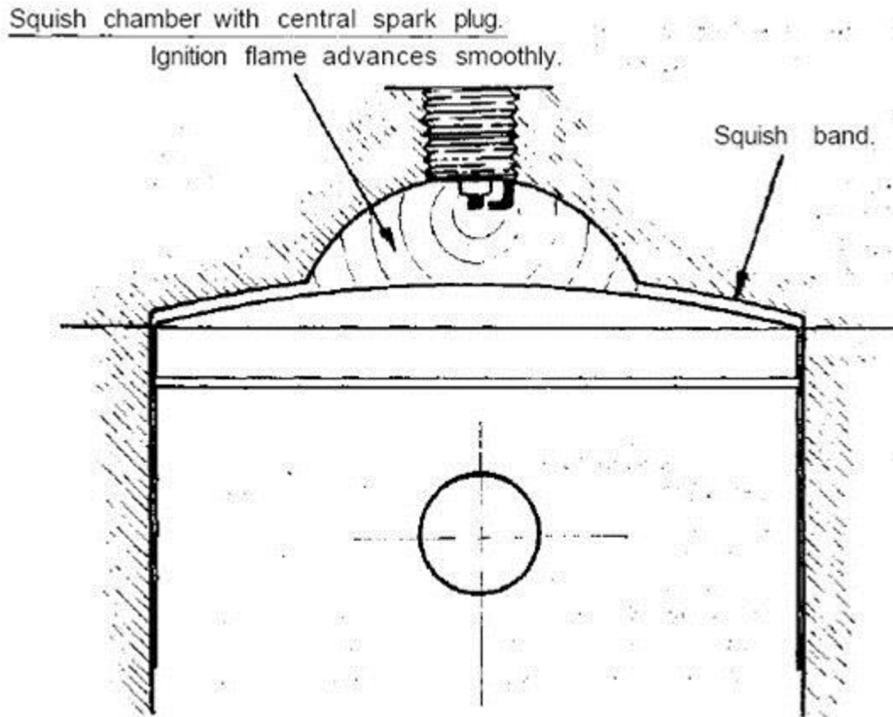

Figure 2 Squish zones provide end gasses with significant cooling and force them closer to the spark plug as the piston approaches TDC-Top Dead Center. This attribute help reduce likelihood for knock.

[17]

1.3 FIRST USE IN MASS PRODUCED CAR

The year 1962 brought two mass-produced passenger cars, which firstly used turbochargers. Chevrolet introducing its new Corvair Monza turbo and Oldsmobile introducing its F-85 Jetfire few weeks earlier. [22] The basic turbocharger consist of a body and a single moving part, small shaft with turbine impellers at both ends. One turbine impeller is caused to be spun by exhaust gasses. Because both turbine are firmly connected to the shaft, the other turbine is spinning as the exhaust gasses pass through the turbo and therefore draws air and centrifugally pressures it into the intake manifolds. Turbocharger by this action increase pressure in intake port which provide more oxygen for combustion. The Chevrolet Corvair turbo was built on this simplicity. The Corvair constructors had to lower their engine's compression ratio to prevent detonation – knock, because there was no mechanism to limit max boost pressure. The Corvair turbo engine reached a peak at high rpm, but felt anemic at lower speeds and suffered from a long lag before the power kicked in. F-85 was powered by 3,5 litre all aluminium V-shaped 8 cylinder engine (Figure 3). Oldsmobile head engine designer Gilbert Burrell made a research of already existing turbochargers (used for example in aircrafts) and found that fitting a wastegate (pressure limiting valve) can limit the turbo-boost pressure. He also wanted to change the dimensions of the turbo and therefore its weight, so it was then able to react more quickly and spin faster. Burrell worked with Garrett AiResearch, a manufacturer of industrial turbochargers, to make these ideas real. Designer Gibson Butler and tester Jim Buckley were involved to construction and spent a lot of time improving the details. By combining a small diameter turbo, where the compressor impeller is 2.5 inches (6,35 cm) in diameter and the exhaust impeller just 2.4 inches (6,096 cm), with a poppet valve wastegate, Oldsmobile's team achieved their goals. The Jetfire turbocharger was able to bring boost at low 1000 engine rpm and gained a torque advantage over the uncharged V-8 max torque at only 1200 engine rpm. Maximum boost pressure of about 5 psi (0,345 bar)

was reached at 2200 rpm and was then limited by the wastegate not to cross this top. In contrast, the Corvair turbo didn't produce 5 psi til 3100 engine rpm and hits its maximum of 11 psi (0,758 bar) at 4500 rpm. When the cars were finished, Oldsmobile's smaller turbo spun at max of 90 000 rpm at the 4000 engine rpm and was able to reach maximum power boost almost in no time.

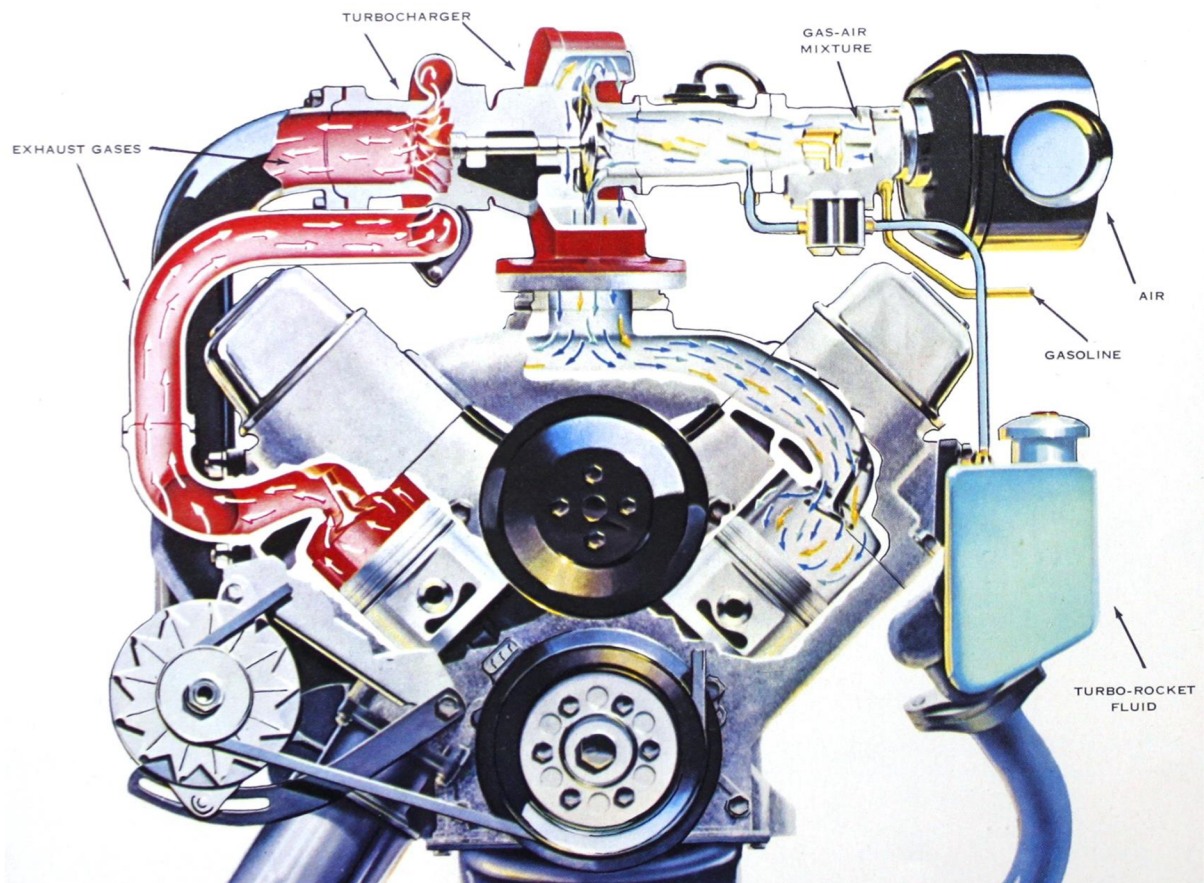

Figure 3 F-85 Jetfire engine with turbocharger and water injection [22]

The turbo, Chevrolet engineers decided to use, had its maximum of 70 000 rpm and the higher weight caused it took more time to reach this maximum. Oldsmobile engineers kept the engine's compression ratio at 10.25:1 to maintain fuel economy and low-end engine performance. Beside they used a wastegate at the intake port to limit the boost, there was still a high probability of detonation, a very harmful element also known as knocking effect. There comes adding a fluid injection system. A 4,7 litre tank of "Turbo-Rocket Fluid"- see Figure 4, (a 50-50 mix of water and alcohol with little rust inhibitor added), was mounted under the hood and was enough for only about 360 km. [22] When the turbocharger run, it also increased pressure in this tank which caused a small amount of the fluid to be injected into the intake port between the carburetor and the turbo. The fluid evaporated, absorbing heat from the intake air and preventing detonation. A warning light informed the driver when the Turbo-Rocket fluid ran low and was incorporated into the bottom of the boost gauge. If it was allowed to run out, a butterfly valve in the throttle body closed to prevent full-power acceleration. The wastegate was operated by two diaphragms in case one would fail. Even if that happened, the cap on the Turbo-Rocket fluid tank would pop off to prevent overboost. And if boost pressure was still too high, the butterfly valve would again shut down the party.

A skandinavian vehicle manufacturer Saab also included water injection to their Saab 99 Turbo and Saab 900 Turbo. But here it had a little different set up compared to Oldsmobile. Firstly they used distilled water with just a little percentage of methanol addition. Fluid was injected by a extra pump into the inlet air charge. Biggest difference was, that only when turbo made boost pressure above 0,8 bar, it began pumping water fluid. Beside the cooling effect it also added a 40 horse power. Problem came when water tank went empty, a seized turbo unit would result, therefore water level had to be monitored. [24] In 1982 Saab was the first car to offer an optional water injection system for its turbochargers. Vehicles made at the end of the 70's and the early 80's are very rare today and, if they are in good condition, are very popular. [9] In the 1980s, turbo engines became popular in the Formula 1 competition, and the potential for water/methanol injection was again exploited. Renault team, in 1983, was the first team to use water injection in the the Brazilian Grand Prix with their Formula Renault RE40. A 12-liter tank was installed in the side cabinet of the vehicle and control unit behind the drivers head. The increased weight of the vehicle was compensated by the corresponding higher ignition potential and the associated higher power. System also included pressure regulator and pressure sensor. Sensor allowed the water injection once the boost pressure in the intake was over 2,5 bar since there was no need below this pressure. [25]



Figure 5 Renault racing car RE40, Formula 1 (1983)[26]

2 THEORY OF WATER INJECTION

Spark ignition engines (SI engines) have several imperfections. The main imperfections are: overheating, low effectiveness, high fuel consumption and emission production. Engineers created many ways how to improve these features. There are many ways how to improve power characteristics, fuel consumption, emission production or energy efficiency of internal combustion engine. In this thesis I will discuss a method, where water or mixture of water and alcohol is injected into combustion chamber. Due to the high enthalpy of evaporation (Δh_v , water), water is preferred as an additional injected liquid. In the Table 1, water is compared to some other chemical substances. Characteristics of gasoline may differ with each type of gasoline.

Chemical substance	Chemical formula	Heat of vaporization (ΔH) $\left[\frac{J}{g}\right]$	Specific heat capacity (C_p) $\left[\frac{J}{kg \cdot K}\right]$
Water	H_2O	2256,4	4187
Gasoline	mixture	310 - 382	2220
Methyl alcohol	CH_3OH	1100	2510
Ethyl alcohol	C_2H_6O	846	2300

Table 1 Specific heat capacity and heat of vaporization of selected substances and mixtures [18][19]

Also shown in Figure 6

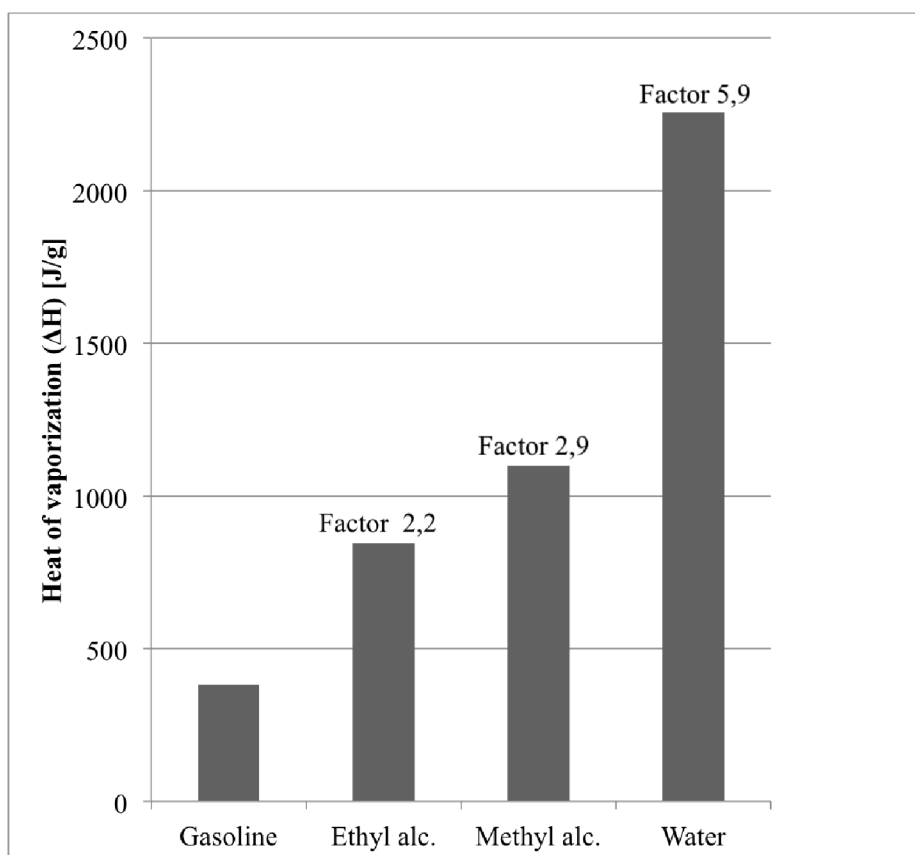

Figure 6 Heat of vaporization

2.1 PRINCIPLE OF OPERATION

Water injection is the process of increasing the performance of combustion engines. In order not to exceed the maximum temperature at maximum output, distilled water is injected in the intake port with the air, or in case of the turbocharged engines it is injected into the return tract of the return or gas turbine compressor. The water / alcohol mixture (also called MW-50) has a similar effect. The evaporating liquid has a cooling effect and reduces compaction. It is also injected during the power stroke to produce steam output and to reduce the exhaust temperature and thereby reduce exhaust backpressure. The process is again the subject of research because it can reduce the emissions of pollutants, in particular nitrogen oxides of combustion engines and jet engines, in this way.[12]

Based on the results of previous research submitted by Thewes [10], the initial concept was extended to two aspects. Instead of injection into the port, direct injection (DI) for condensate as well as gasoline injection was considered. Furthermore, the concept of condensation has been changed to use the entire exhaust gas condensate and not only the EGR condensate.¹ At a dew point of approximately 40 ° C to 56 ° C. The mass of the contained water is generated exclusively during the combustion of the fuel.

Cooling effect of evaporation of injected water is used to lower the temperature and pressure in the reservoir. This allows more efficient timing of sparks due to reduced sensitivity. [11] Due to the high enthalpy of evaporation (Table 1), water is preferred as an additional injected liquid. At the same time, the water has a higher specific heat capacity (cp) than air. For this reason, the additional cooling effect during compression and combustion is carried out when water is added to the cylinder pack. The theoretical assessment by fuel / air cycle was performed to evaluate the influence of heat capacity and enthalpy of water vapor on the temperature of the mixture when water was applied. It is considered replacement gasoline. Figure 7 shows three different scenarios:

1. Reference cycle without water injection.
2. Cycle where water injection is applied, but water is assumed to be injected into the gas phase to prevent the influence of the evaporation enthalpy.
3. Cycles through water injection, while additional cooling due to evaporation of water is considered. [21]

¹ Exhaust gas recirculation is a technology that allows to increase both the economic and environmental parameters of combustion engines. It is based on the principle that a portion of the exhaust gases are fed into the combustion chamber in the next working cycle. Technology is also known by abbreviations EGR - *Exhaust Gas Recirculation*, or AGR - *Abgasrückführung*.

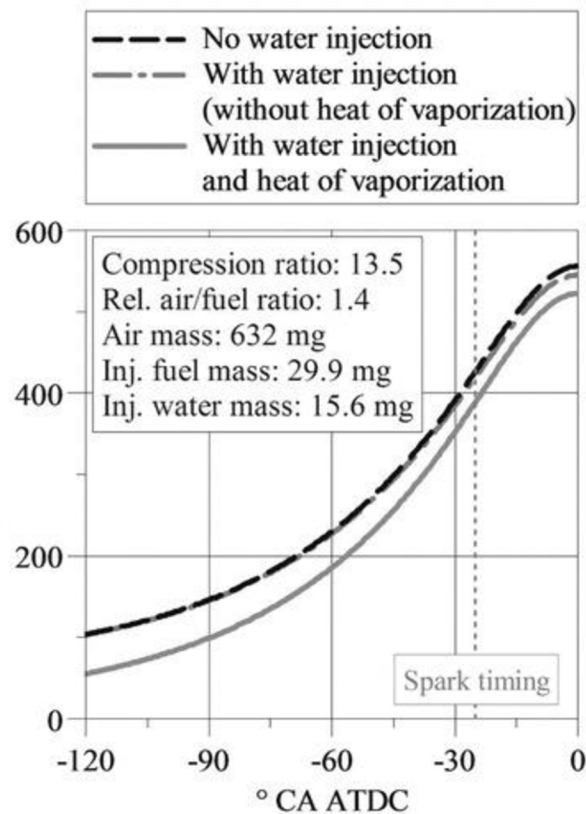

Figure 7 Influence of specific heat and evaporation enthalpy on the mixture temperature in the fuel and air cycle [21]

2.2 DECREASE IN TEMPERATURE

Cooling systems went through many years of research. There are many models of cooling the engine, mostly from the outside of the engine. Almost each modern combustion engine (spark ignition or diesel) has cooling consisting of coolant reservoir, water pump, thermostat, hoses and the most important part radiator. To prevent engine running cold, thermostat opens a big circuit after small circuit is heated to temperature between 90-110 °C (which depends on the engine). This is very effective way to cool the engine block and prevent it to overheat. However this keeps the engine in working temperature, the most important part of the engine is the combustion chamber, which the liquid coolant from outside is not able to regulate instantly. To cool down temperature from the inside of combustion chamber more efficiently, we need to inject coolant agent into it. The agent can not be toxic because of emissions, and should not decrease power outcome. Injecting extra amount of fuel is often used to cool down a combustion chamber. Fuel is injected with the same nozzle, but at earlier time. However this is a effective step in cooling a chamber, it also increases a fuel consumption and NO_x production which is undesirable. [6]

In internal combustion spark ignition engines, water injection, also known as Anti-Detonation Injection (ADI), is a method of cooling the combustion chambers of engines by adding water to the cylinder or incoming fuel-air mixture, generally enabling greater compression ratios and essentially eliminating the problem of knocking. Knocking effect or pre-detonation is a proces, where the combustible mixture comes to heated-up chamber, and the high in-cylinder temperature and pressure allows it to detonate before spark plug ablaze the mixture. This

causes releasing more pressure into cylinder while the piston is at the compression stroke and causing enormous damage to the engine parts and also decreasing engine power output. Injecting a water lowers the temperature and therefore pressure through the latent heat of vaporization of the liquid water to gaseous form preventing the extra damage. The low-temperature water injected to air/fuel or enriched O_2 air/fuel mass demands less work in the compression stroke, thereby increasing overall efficiency. It also promotes increased mass flow through the engine for increased power output and efficiency.[7][31]

The water cooling system operates on the principle of pumping water from a small tank, the water is then sprayed as a mild fog-like sling directly into the suction line. Overpressure space where it evaporates. The combustion temperature can thus be reduced by about 34°C . [8][21] Figure 9 shows a input data of research made by Wei Mingrui et al. [21]. For a model they used a gasoline direct injected engine (fuel injected at 660°CA to 680°CA), employed a compression ratio of 13:1. Water was injected on the same principle but at 640°CA to 650°CA . Both injectors spray directly into combustion chamber and are situated opposite to each other (see Figure 8). All computations have been done at the engine speed of 2000 rpm. In their research they compared engine output using various mixtures in the combustion chamber. Mixuters consist of pure gasoline (PG) and pure gasoline with different water addition (WA). WA5 presents a mixture of pure gasoline as a base and addition of mass of water equal to 5% of the mass of gasoline, WA10 – 10% mass of water, WA15 – 15% mass of water, WA20 – 20% mass of water, WA25 – 25% mass of water. In the Figure 10 we can see results of the computations of the temperature of suction gas inside the combustion chamber. These were done at the end of the fuel injection and before ignition. As the author presents temperatures lowered as shown in the Table 2.

Various cases	WA5	WA10	WA15	WA20	WA25
Temperature lowered by: [K]	7,53	15,21	21,64	28,09	33,71

Table 2 Results of computation with water injection

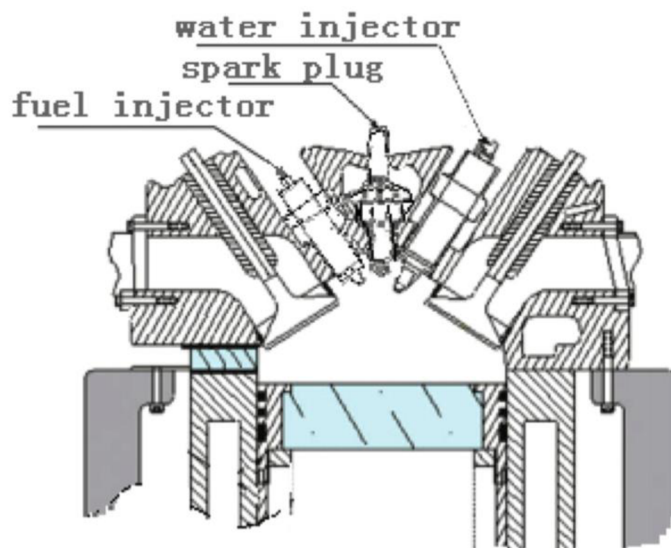

Figure 8 Schema of engine used for computations by [21]

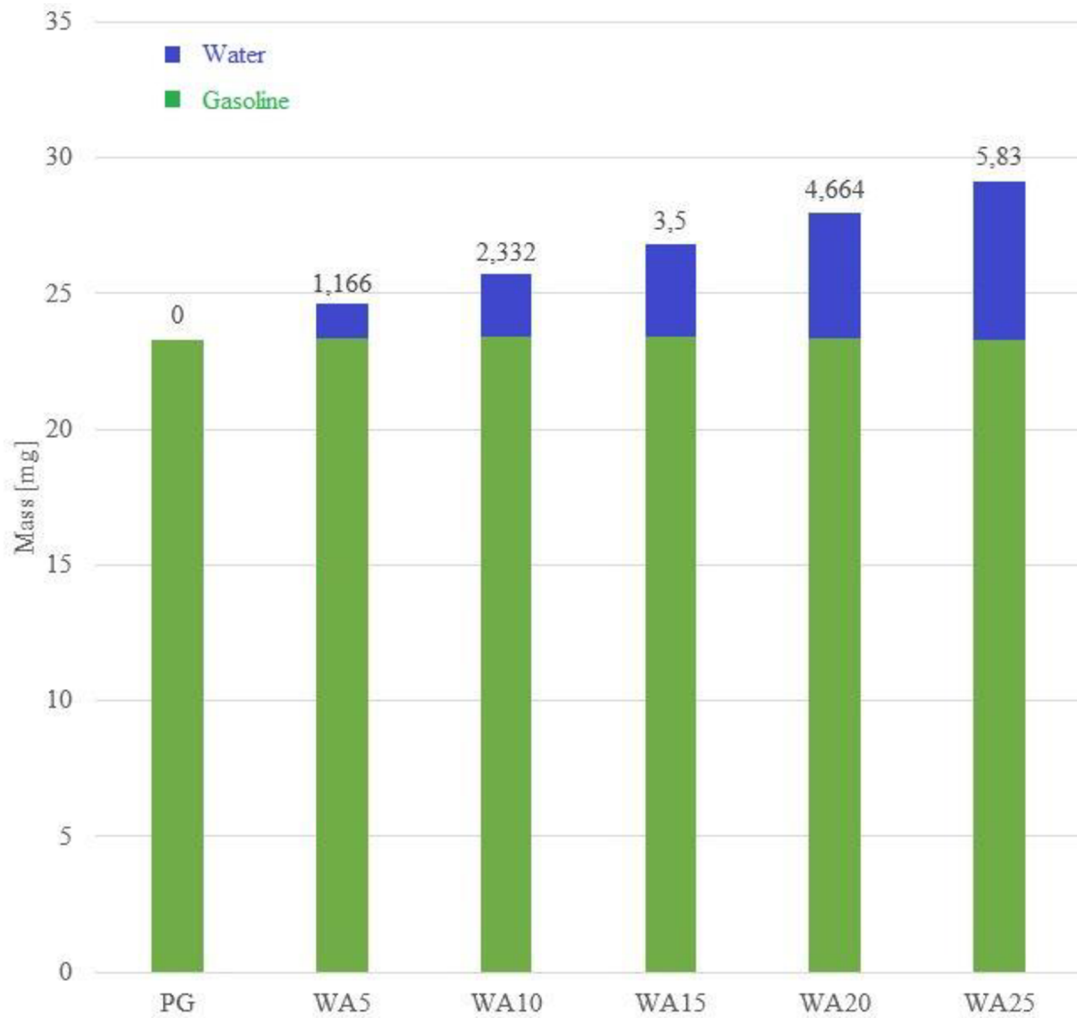

Figure 9 The gasoline mass (23,32 g) and different ratio per a cycle for various cases [21]

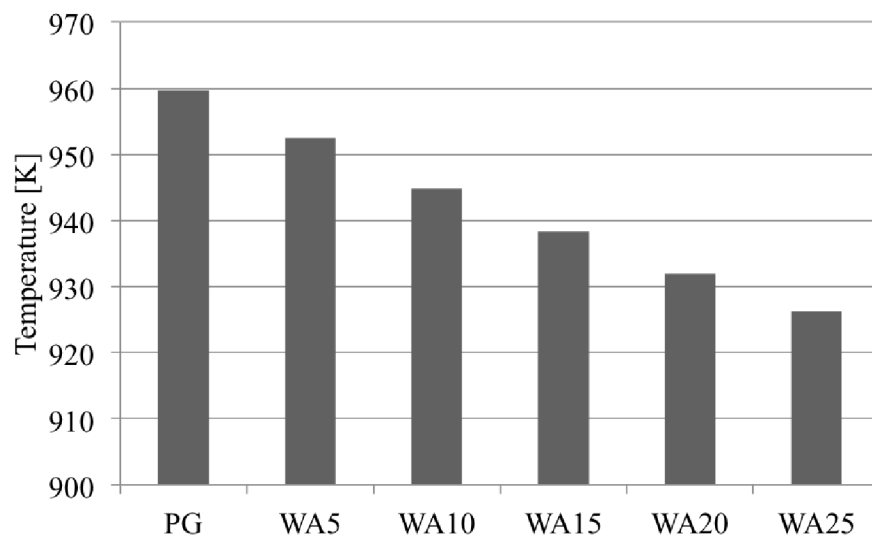

Figure 10 The effect of water injection on the in-cylinder temperature of the suction gas at the end of fuel injection (680°C - Crank Angle) [21]

LOWER EMISSIONS

Emission restrictions in Europe began already in 1970 with the NEDC (New European Driving Cycle) test cycle. The European Driving Cycle (NEDC) consists of two sections - urban and rural. The city area consists of four recurring sub-urban cycles. Each of them has 15 phases, including idling, acceleration, steady speed, deceleration and more. The maximum speed is limited to 50 km/h in the city area. This section measures 4,052 km. The extra-urban section has only one cycle with 13 phases (idling, acceleration, steady speed, deceleration, etc.). Maximum speed here is limited to 120 km/h and the theoretical length is 6,955 km. In total, the vehicle drives 11,007 km for the whole test. The entire NEDC test runs for 1180 seconds. It is performed at pre-selected gears, which are always the same for all cars and the vehicle must have been driven at least 3000 km. Prior to the test, the vehicle temperature is between 20 and 30 degrees. The NEDC methodology calculate the same test for all cars (always divided into urban and extra-urban areas). Because there was difference between official and real emissions, a WLTP (World Harmonized Light Vehicle Duty Test Cycle) took place. The WLTP consist of two cycles: WLTC (World Harmonized Light Vehicle Duty Test Cycle) and RDE (Real Driving Emission). It is a driving cycle for passenger cars on a cylindrical test room. WLTC works with three categories of passenger cars, devided by power and maximum speed. The first category includes less efficient vehicles with a power output less than or equal to 22 W/kg. This category is tested for three modes - low load, medium load and high load. The second category, with a power output of 22 to 34 W/kg, is tested for - low load, medium load, high load and extra high load. The third group, where most of the produced cars belong works with a power output of more than 34 W/kg, divided into two categories - cars with a maximum speed of 120 km/h and over 120 km/h. The individual stages of the test are similar to the second category, also four different loads. RDE deals with the real conditions. Test takes 90 to 120 minutes, where one third will be done in urban areas, another third will be done on extra-urban roads and the last third will contain driving on the highway with the top speed of 145 km/h. Another real factor will be air-conditioning which is to be turned on. For the beginning it will be privileged by the “conformity factor”, the emission norm for the WLTC will be multiplied by 2,1. This factor will be lowered to 0,5 until january 1st 2021. [27] In Table 3 are shown EURO 6d standards for every new approved vehicle in European Union.

Emission [$\frac{g}{km}$]	CO	THC	NMHC	NO _x	PM
EURO 6d	1,0	0,10	0,068	0,06	0,0045

Table 3 EURO 6d standards [28]

Where: CO- carbon monoxide, THC- unburnt hydrocarbons, NMHC- non-methane hydrocarbons, NO_x- oxides of nitrogen, PM- solid particles.

Another significant reduction in CO₂ emissions after 2020 is mandatory in the United States of America. It may also become mandatory in Europe, depending on the legislation on CO₂ emissions of passenger cars. The growth of hybrid and plug-in hybrid vehicles could be a way to reduce CO₂ emissions, as a result of the current legislative framework that does not legally co-relate CO₂ emissions from CO₂-generated electricity production. With respect to the level of the targets, options are defined in terms of the percentage reduction in 2030 (versus the 2020/2021 targets for cars and vans) as the new regulation will need to be based on the new WLTP test cycle, while the exact 2021 WLTP-based targets are not yet known. A wide range of options have been considered ranging from 10% to 50% reduction of the targets by 2030.

This includes options consistent with the statements made by the Commission in the Council at the time of adoption of the 2014 Regulations. An option with 10% reduction by 2030 was not modelled as the new baseline scenario already achieves more than 10% improvement by 2030. A summary of the range of potential CO₂ reduction trajectories is provided in Table 4. [15]

Name	Description	Cars		LCVs	
		2025	2030	2025	2030
Low (L) [20%]	Linear 20% reduction on 2020/1 for cars and LCVs	9.4 %	20.0%	10.6%	20.0%
Central (C) [30/25%]	Linear 30% reduction on 2020/1 for cars; 25% for LCVs	14.7%	30.0%	13.4%	25.0%
High (H) [40%]	Linear 40% reduction on 2020/1 for cars and LCVs	20.3%	40.0%	22.5%	40.0%
68g NL	Reduction by 2025 to equivalent of 68g/km / 105g/km NEDC for cars /LCVs, then linear trajectory to equivalent of 25g/km / 60g/km NEDC for cars / LCVs by 2050	28.4%	41.4%	28.6%	36.1%
Very High (V) [50%]	Linear 50% reduction on 2020/1 for cars and LCVs	26.5%	50.0%	29.3%	50.0%

Table 4 European standards - Summary of the different options for CO₂ reductions (% reduction to 2020/2021 target); where LCVs are “Light Commercial Vehicles (VANs)” [15]

As the emission standards are getting more strict, water injection also offers a possible solution. Most of the emissions are formed under temperature peak or fuel-rich mixtures. [21] By injecting water and therefore lowering the temperature inside the cylinder, we are able to lower the emissions. In chapter 3, I present model simulation which also result in lowering CO and hydrocarbon emissions but slightly increases CO₂ production.

2.3 PRESENT TECHNOLOGY AND FUTURE

At present, water injection technology is mainly used in various Rally and tournament engines such as Subaru WRX, Ford Cosworth, Lancia Delta, Škoda Fabia, Alfa Q4. Especially in areas with extreme performance, water injection shows its strengths. The desired cooling can always be achieved by the amount of injected liquid; thus achieving the maximum degree of efficiency of the turbocharger, respectively. compressor. In addition, the BMW M4 GTS with water injection was developed in cooperation with BMW M GmbH and BOSCH. The first prototype was used as a safety car in the MotoGP 2015. The following year, the M4 GTS was launched with water injection in series. Using the injection of water, the combustion air temperature of the M TwinPower Turbo combustion air decreased by 25 ° C. During this period, it was mentioned in the media that BMW tested injection of water into cylinders even on significantly smaller vehicles. BMW has been working on a water injection system with Bosch, which claims that water injection into cylinders can reduce fuel consumption by up to 13% and CO₂ emissions by 4%. Here is the principle of water injection into cylinders known for decades and was used in aviation. For refilling engines, it is essential to add the coldest mixture to the cylinder, as the lower the temperature, the larger the amount it is possible to add to the cylinder. If the intake air temperature is reduced at the same time, the mixture will

be less prone to detonation burns, premature ignition of hot components. This means that the vehicle's engine may have a higher compression ratio, the combustion poorer mixture, though more efficient.[8]

A similar system is also equipped with the BMW 1-series hatchback prototype where the rate of efficiency increases the harder it is driven. That's because the cooling effect reduces temperatures sufficiently to avoid any need to inject more fuel than required when operating at or near full throttle. There are improvements in the low and medium throttle range as well. Lower temperatures reduce the risk of engine knock, allowing the engine run at a higher compression ratio. In this 1-Series prototype powered by a 1.5-liter turbocharged three-cylinder engine (see Figure 11) with water injection, the compression ratio increased from 9.5:1 to 11.0:1. System draws water from a hand-filled tank in the luggage compartment. While thy Bosch system does not offer this improvement the water injection system in a BMW 1-series prototype was equipped with a water recovery system that also uses condensed water from the air conditioning system to top up the tank. After switching off the engine, all water from the hoses is taken back to the insulated tank to prevent corrosion or freezing of water in the hoses. System is not intended into extreme climatic conditions. Productions models may in fact also feature a small auxiliary tank in the engine bay, although it's expected that this will require refilling only every 18 000 km or once a year (provided the air-con produces sufficient water). BMW will bring this technology to more common vehicles in a close future. Bosch stated that will offer their water boost system to other manufactures too. As the water injection is simple and very effective this system will probably spread worldwide. [28][30][32]

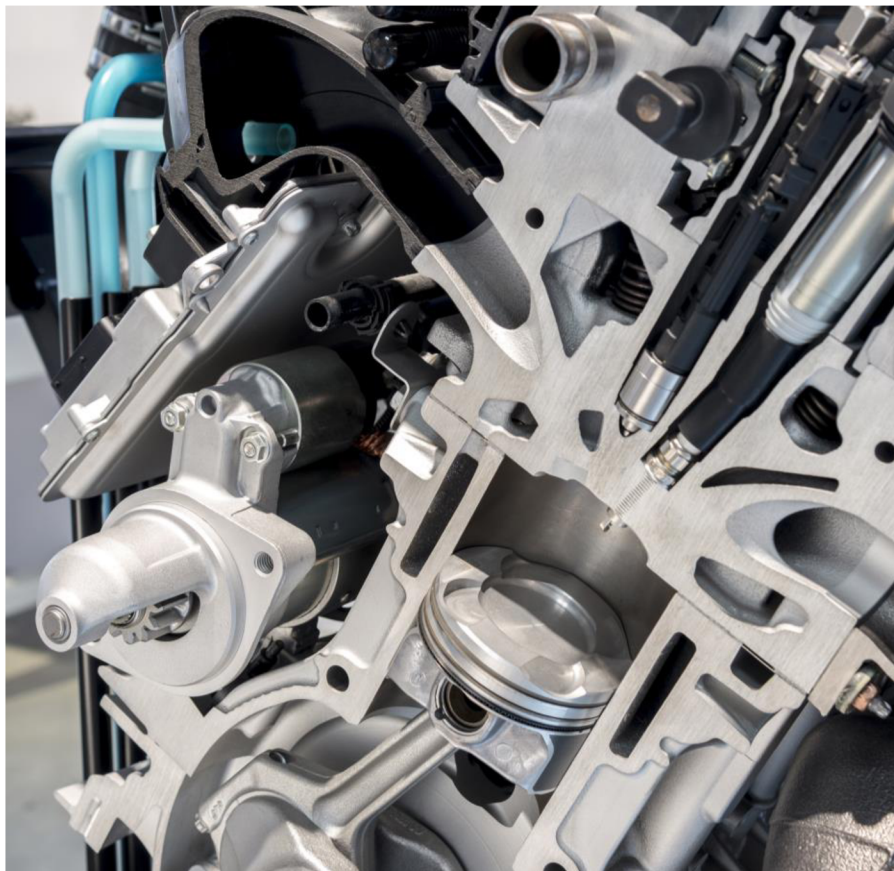

Figure 11 BMW 1-series 1,5 litre prototype engine with water injection [32]

3 WATER INJECTION SIMULATION

Main goal of this chapter is to confirm theoretical data presented in the thesis. Performance and emission production was tested. For simulation was used a computational program GT-POWER, which is available for study purposes at Brno University of Technology. Work has started with basic SI engine available in the templates of program (see Figure 12).

Initial characteristics:

Number of cylinders	4 (in-line)
Bore [mm]	86
Stroke [mm]	86,07
Volume [cm^3]	1999,85
Compression ratio	9,5
Fuel injection	Direct
Number of valves per cylinder	4 (2 for intake, 2 for exhaust)
Type	4-stroke

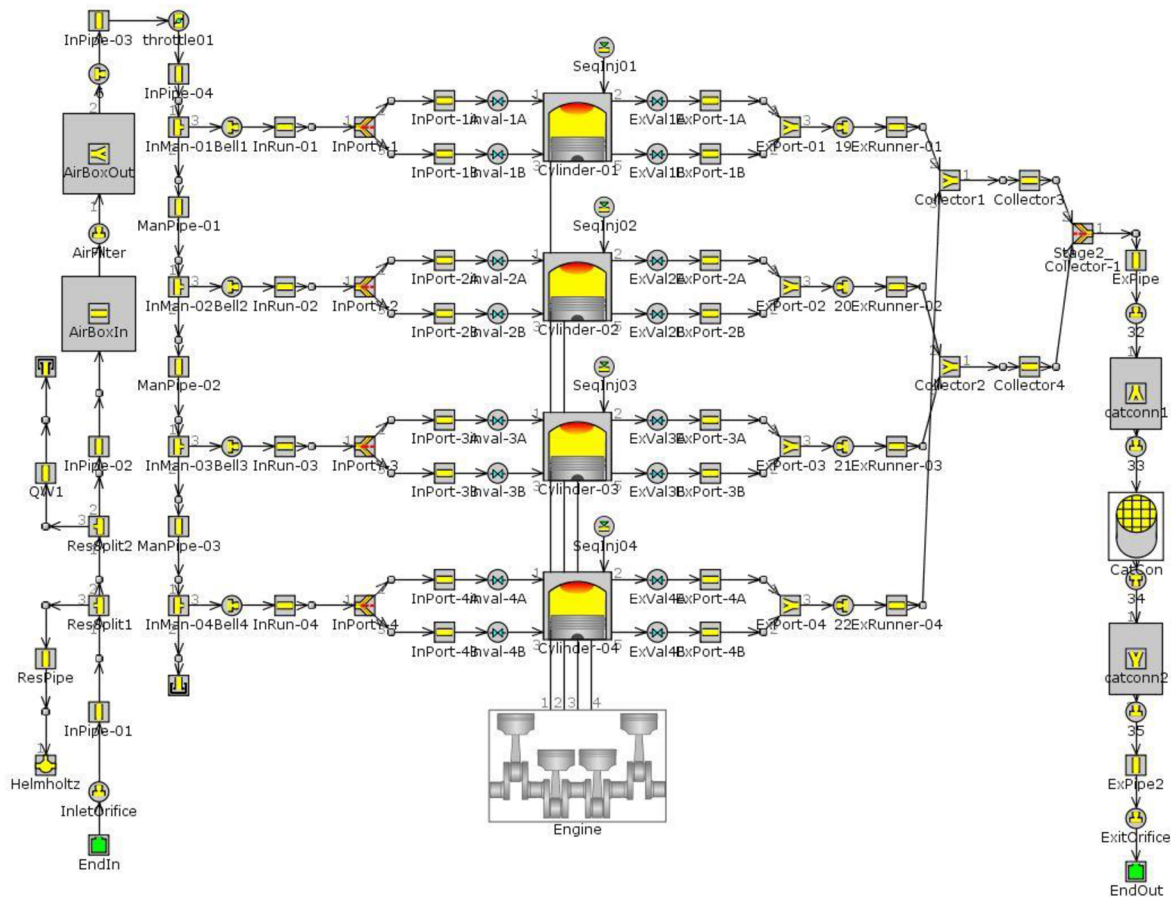

Figure 12 Schema of the initial engine

First step was to figure out what are the goals and how to reach them. To create some usable data, a comparison of direct and port water injection using a distilled water was set as a goal. The only difference seemed to be the position of the injector. There are 9 types of injector in the program. Because injectors have pre-defined the connection location, there are different injectors to both cases.

3.1 PORT WATER INJECTION

3.1.1 SET UP

In this case a sequential injector is used as is used for injection of fuel. Amount of injected water was set by the equation: $x \cdot [\text{WaterPercentage}] / 100$, where x present amount of injected fuel into combustion chamber, $[\text{WaterPercentage}]$ is parameter to be set, to regulate this percentage easily through case set-up. This setting allows the simulation to change the mass of injected water based on amount of the mass of fuel independently during the simulation, securing that it always count with exact percentage that was set. Water injectors are placed at the intake port of each cylinder (see Figure 13). Timing was set equal to fuel injector at 368° .

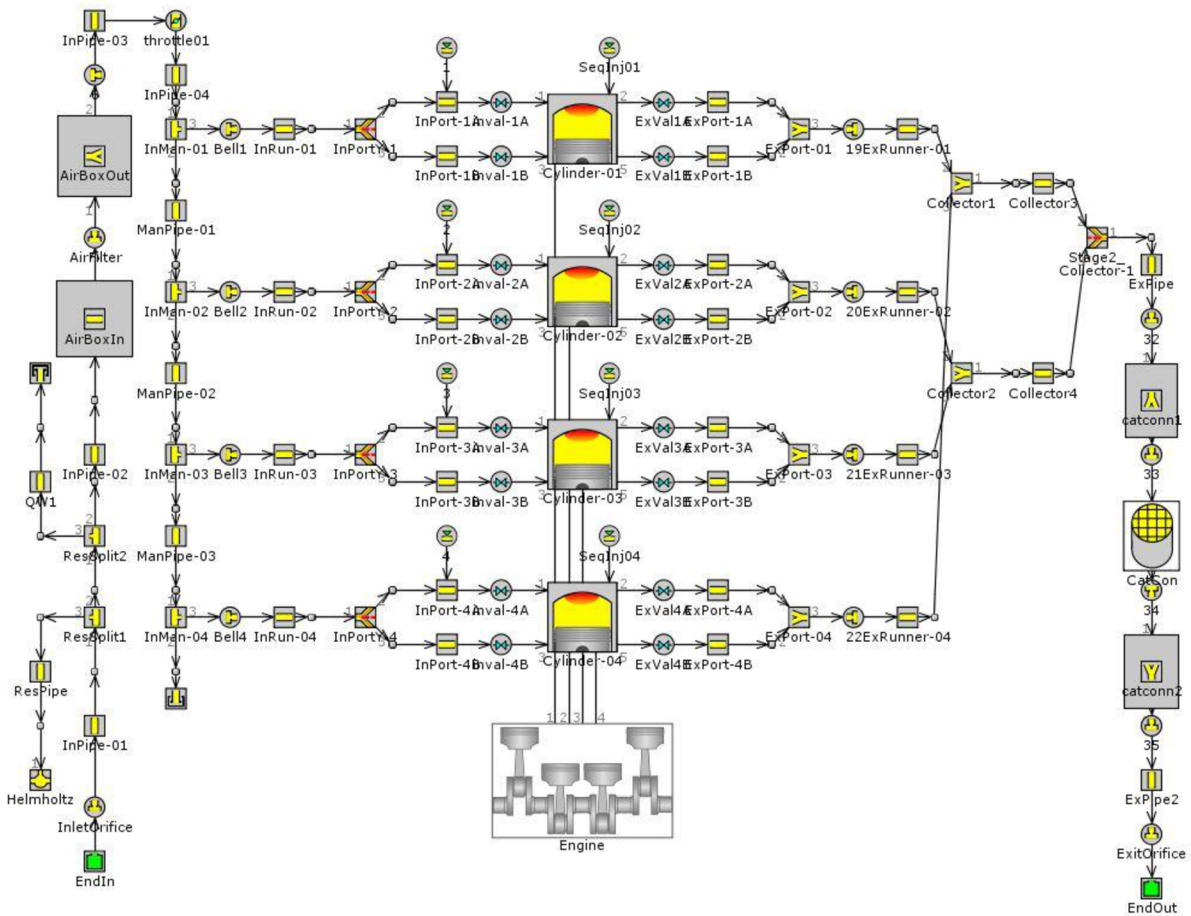

Figure 13 Engine model for port injection of water

Simulation went on 2000 rpm and the temperature of the intake air was 25°C at the pressure 1 [bar]. There were 13 cases in the simulation and differed with the percentage of injected water as shown in the Table 5.

Case	1	2	3	4	5	6	7	8	9	10	11	12	13
Water %	0	5	10	15	20	25	30	35	40	55	70	85	100

Table 5 Percentage of injected water in various cases

3.1.2 RESULTS

Here are presented some results based on set up in GT-POWER. Results are focused on increased power output, decrease of the in-cylinder temperature and change of specific type of emissions.

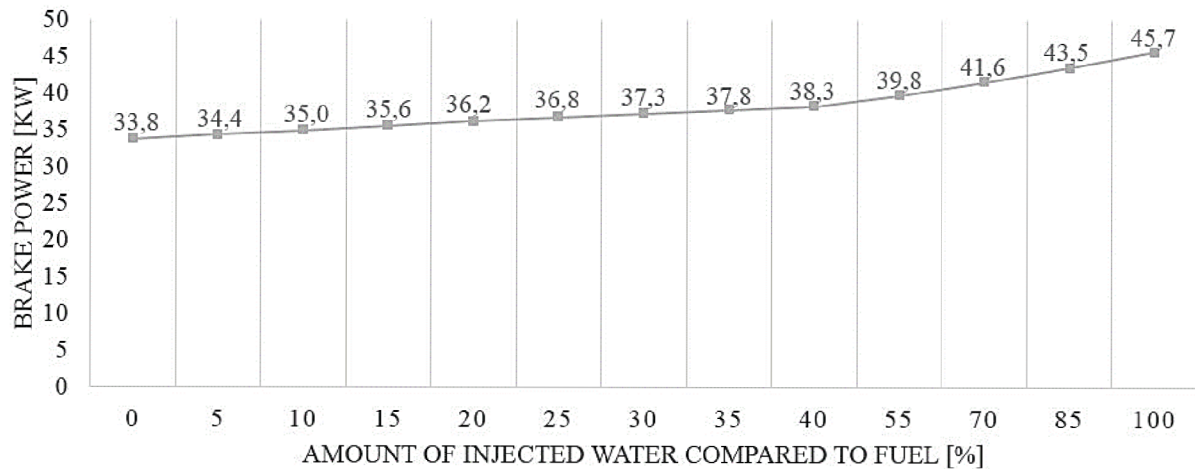

Figure 14 Increase in brake power

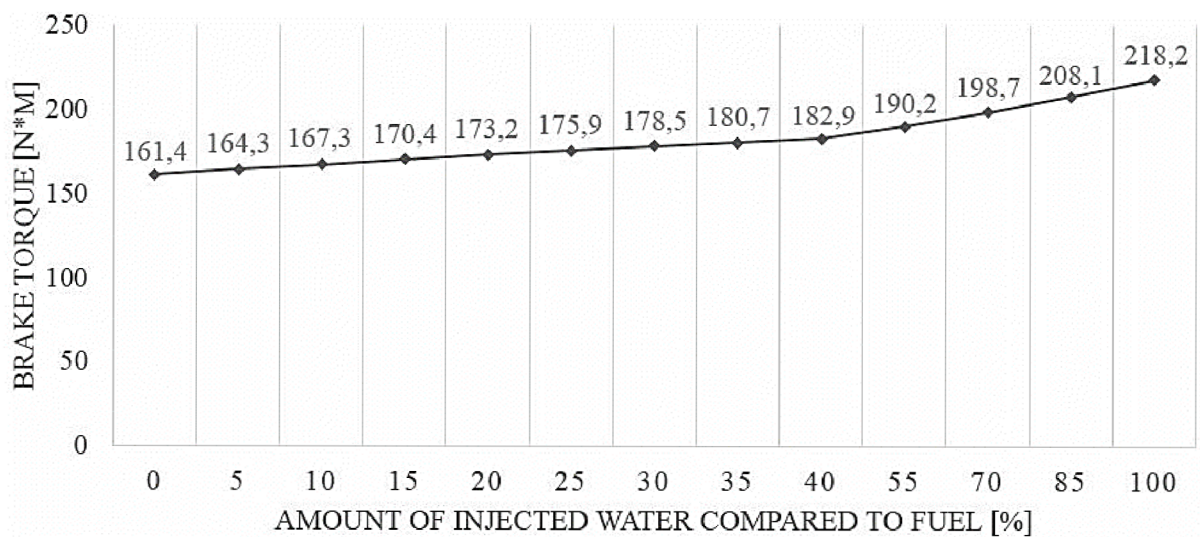

Figure 15 Increase in brake torque

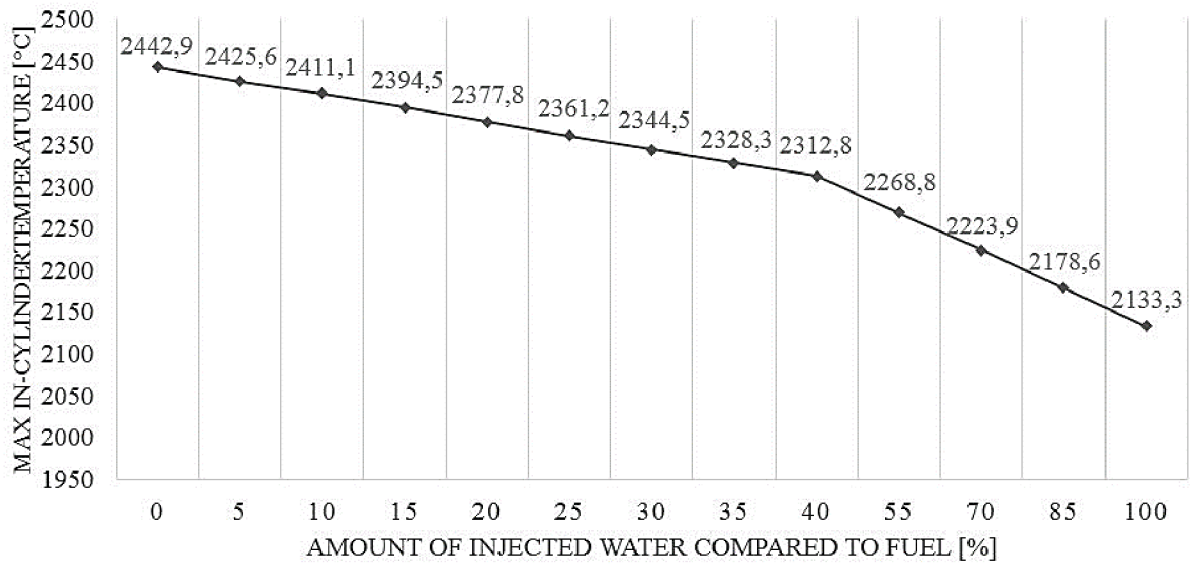

Figure 16 Decrease of maximum in-cylinder temperature

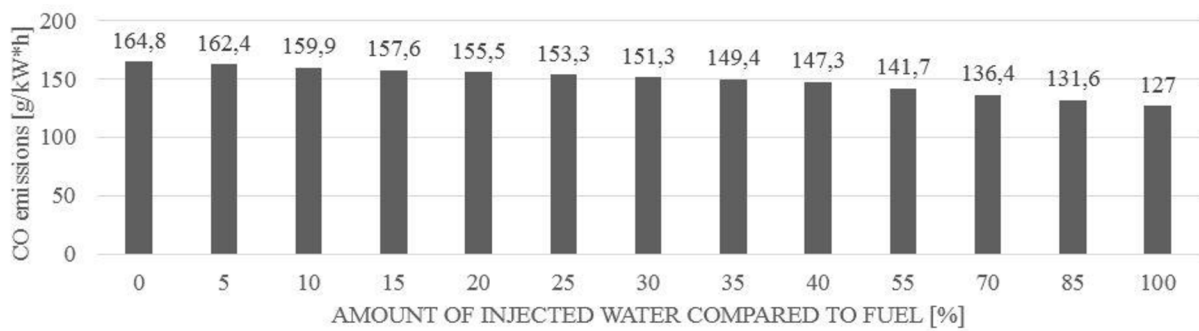

Figure 17 CO emissions decrease

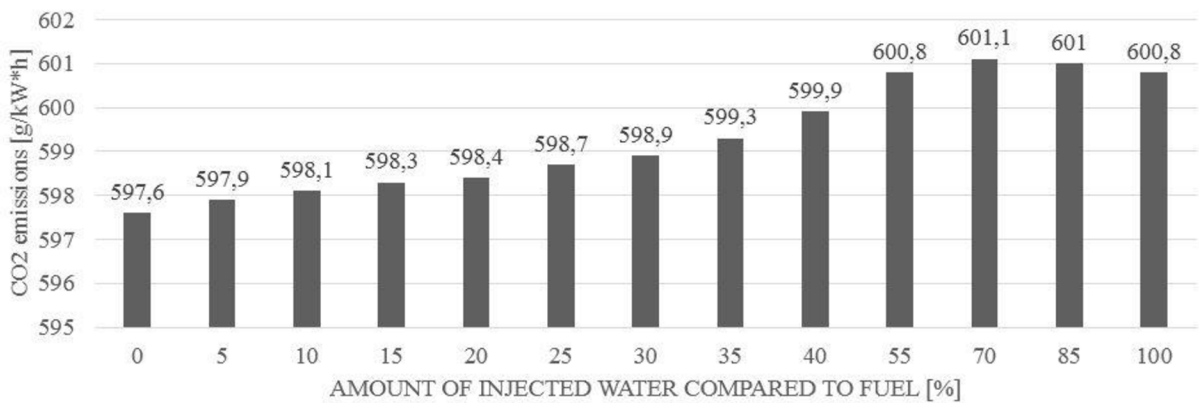

Figure 18 Change of CO₂ emissions

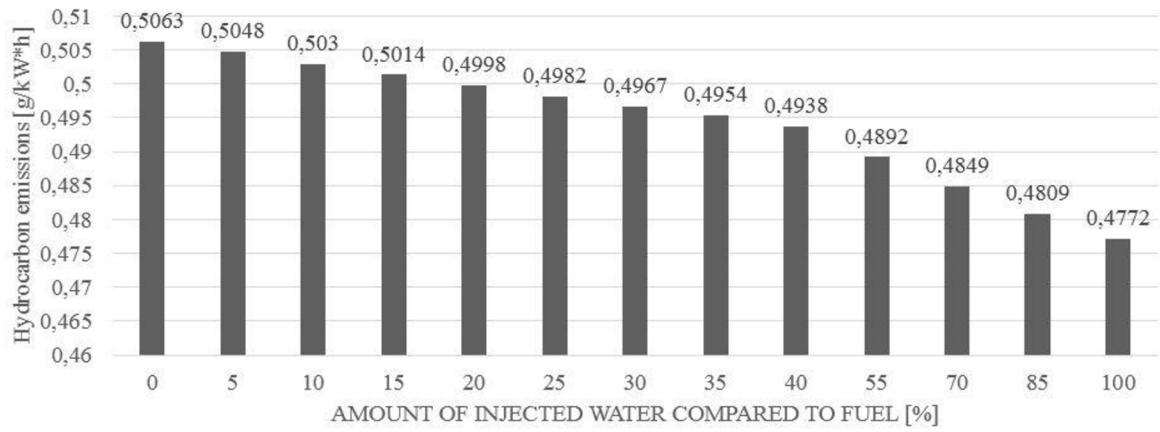

Figure 19 Hydrocarbon emissions decrease

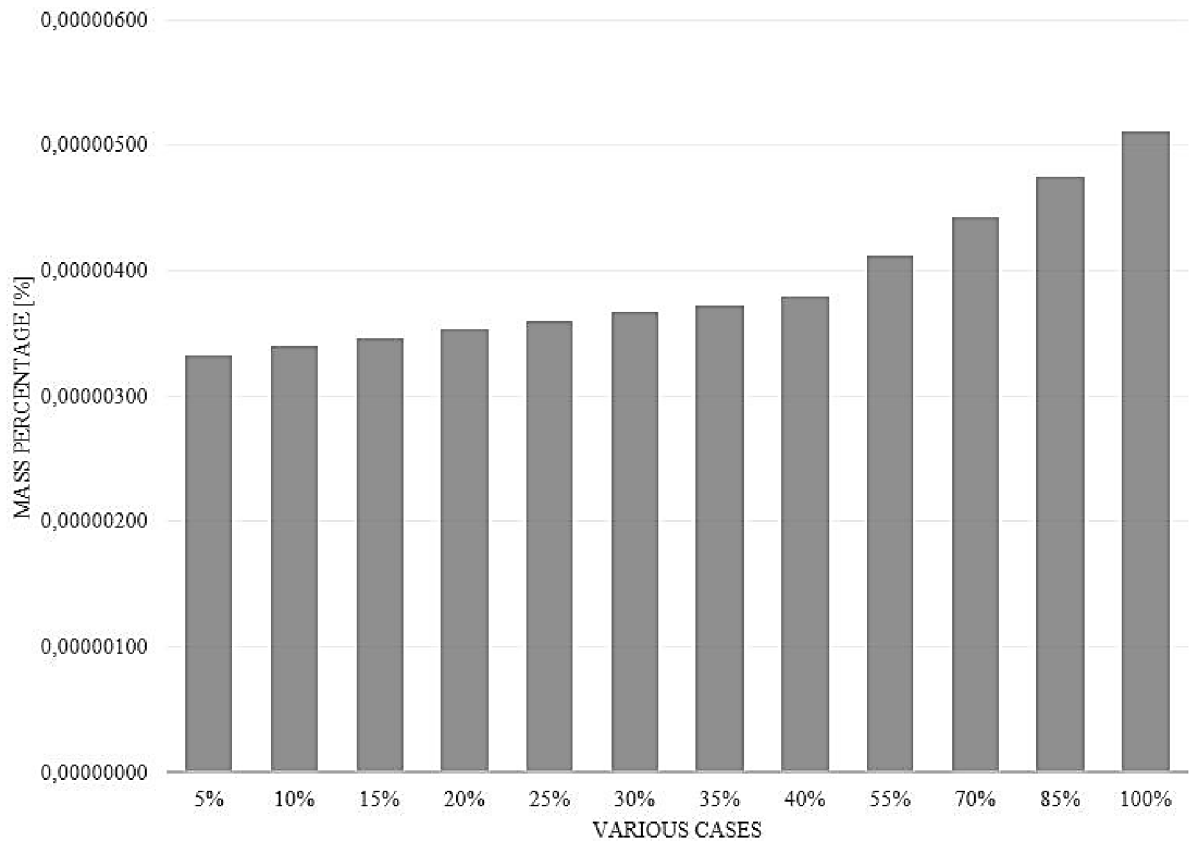

Figure 20 NOx percentage in total mass flow

3.2.2 RESULTS

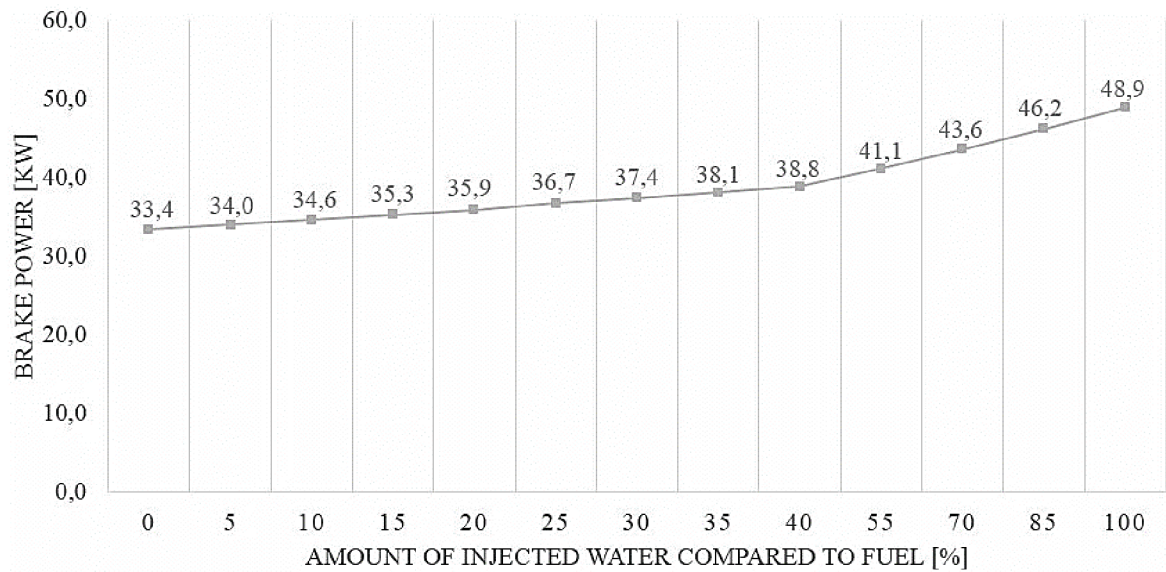

Figure 22 Increase in brake power

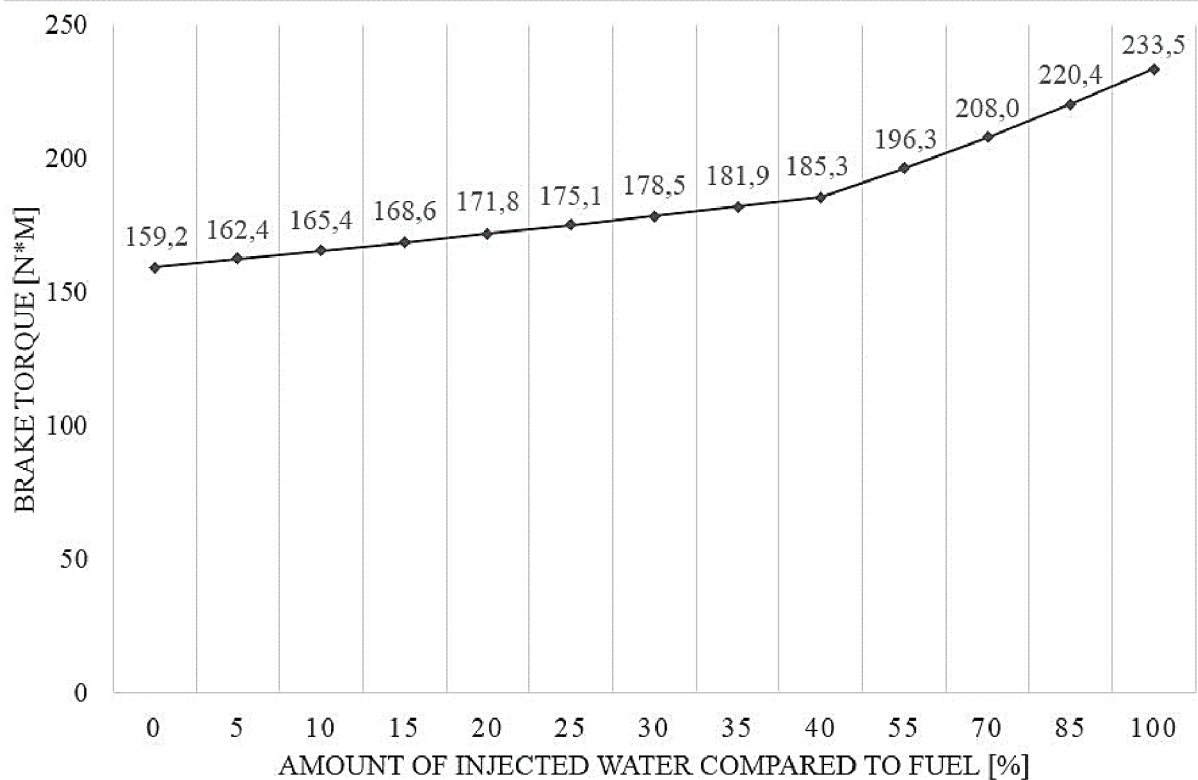

Figure 23 Increase in brake torque

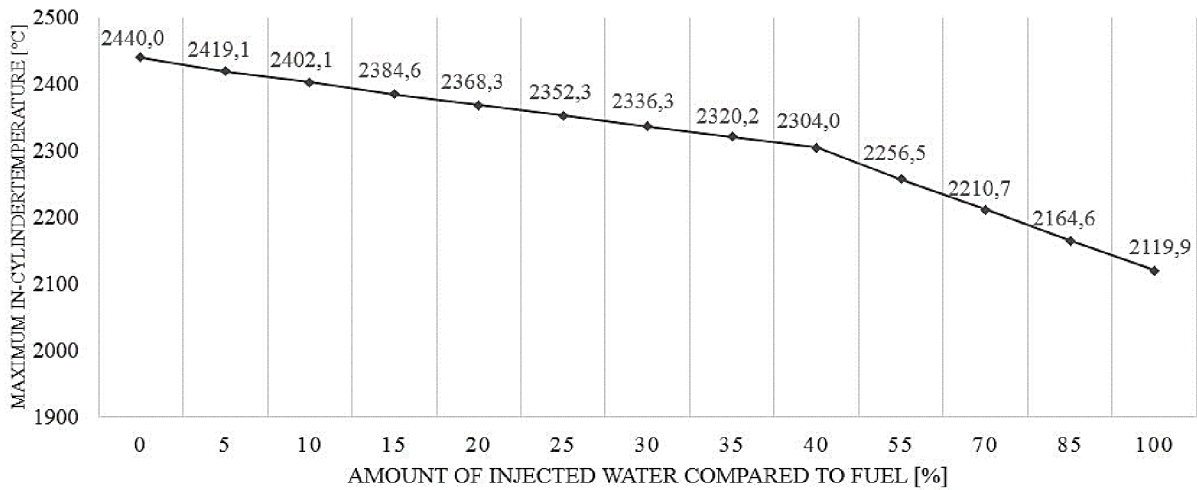

Figure 24 Decrease of in-cylinder temperature at the beginning of fuel injection [368° Crank angle]

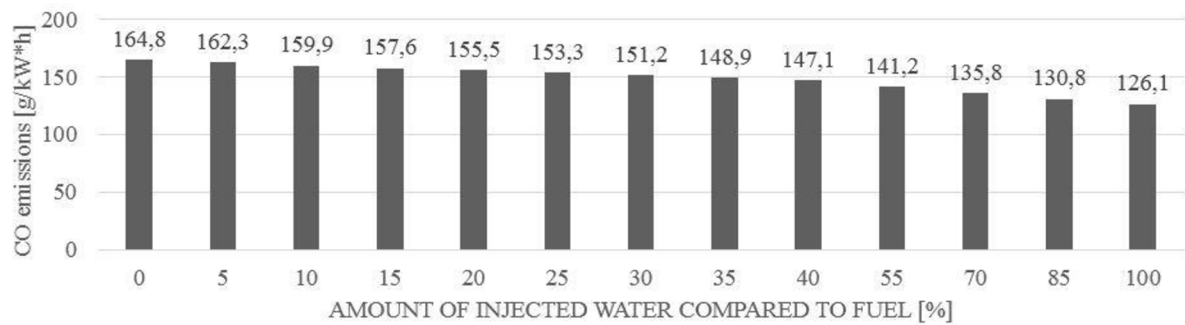

Figure 25 Decrease in CO emissions

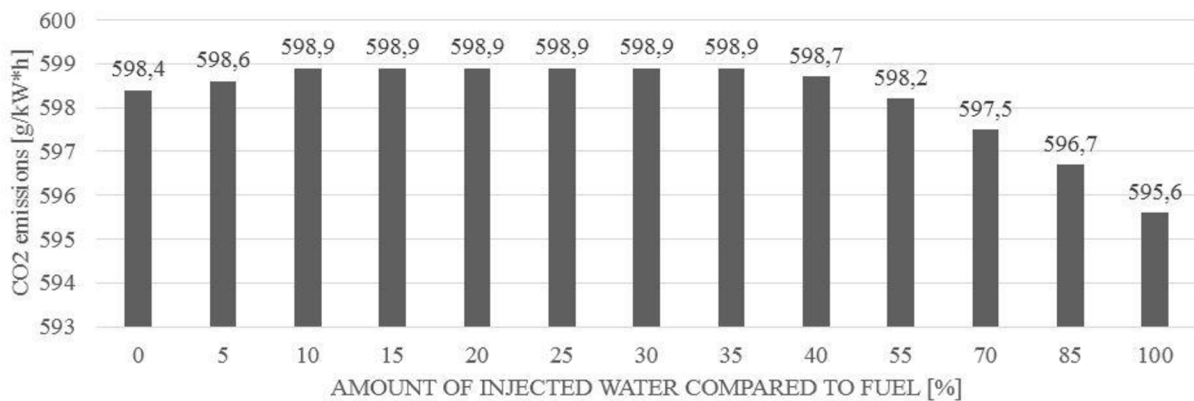

Figure 26 Change of CO₂ emissions

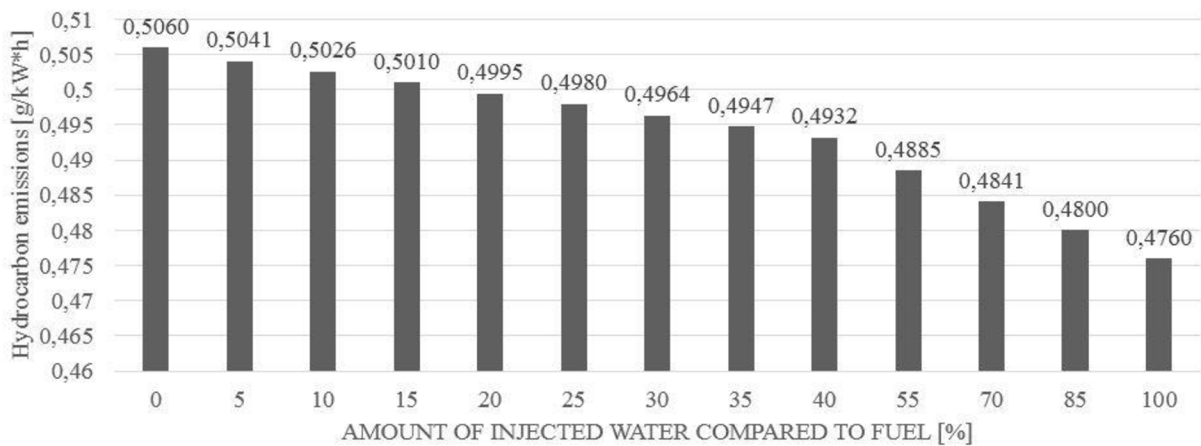

Figure 27 Decrease of hydrocarb emissions

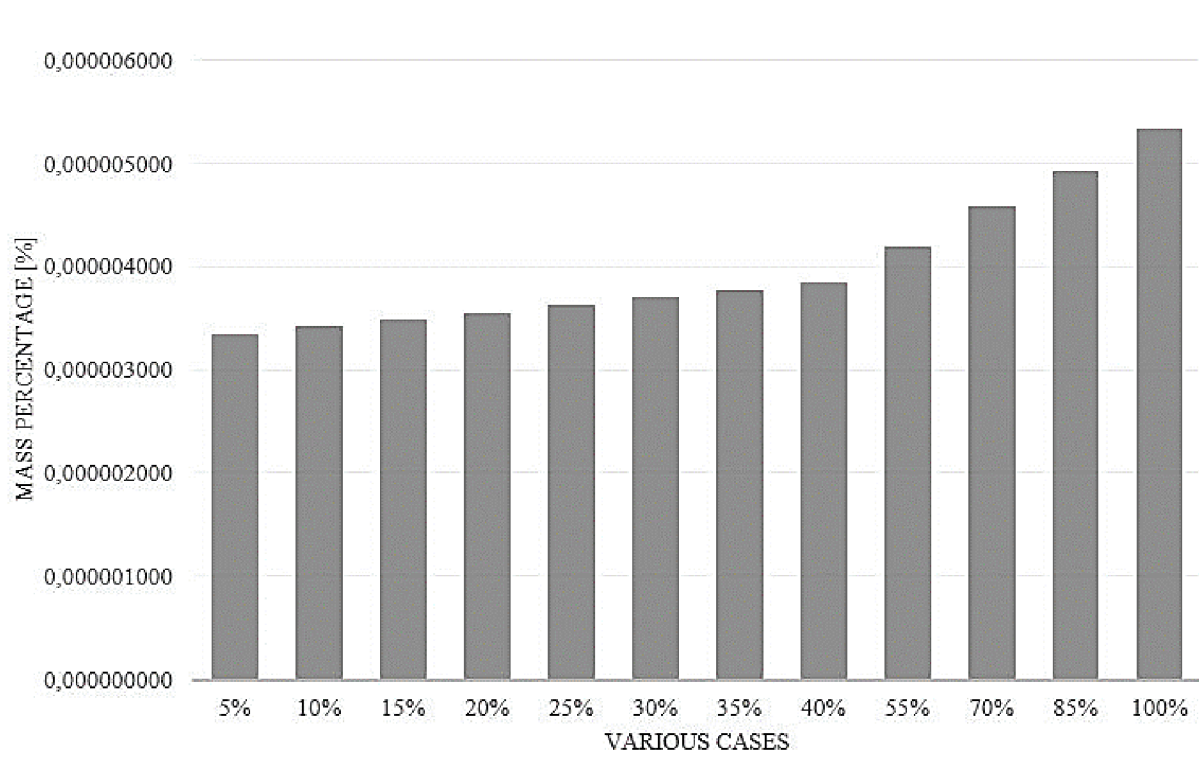

Figure 28 NOx percentage in total mass flow

3.3 DISCUSSION

Simulation has shown that the trend of improving the characteristics by injecting water to combustion chamber are worth to be under research. A direct water injection and port water injection was compared. With the port water injection improvement in power characteristics (Figure 14, Figure 15) do better with smaller amount of water injected, but as the amount increases to 30 %, direct water injection shows better improvement (Figure 14, Figure 15). Same trend happens with the temperature, but already with 10%. This can be caused by the fact, that in the initial – 0% of water injection, results show different numbers even though the engine models are the same. In case of emissions, an improvement happened in CO and hydrocarbon emissions. The CO₂ emissions slightly increased with a peak in 70 % with port

water injection and a peak from 10 to 35 % with direct water injection. In Table 6, Figure 29 and Figure 30 data for better review are shown.

Parameter	Model	No water	30% of water	100% of water
Brake power [kW]	Port injection	33,8	37,3	45,7
	Direct injection	33,4	37,4	48,9
Brake torque [N.m]	Port injection	161,4	178,5	218,2
	Direct injection	159,2	178,5	233,5
In-cylinder temperature [°C]	Port injection	2442,9	2344,5	2133,3
	Direct injection	2440	2336,3	2119,9
CO emissions [$\frac{g}{kW.h}$]	Port injection	164,8	151,3	127
	Direct injection	164,8	151,2	126,1
CO2 emissions [$\frac{g}{kW.h}$]	Port injection	597,6	598,9	600,8
	Direct injection	598,4	598,9	595,6
Hydrocarbon emissions [$\frac{g}{kW.h}$]	Port injection	0,5063	0,4967	0,4772
	Direct injection	0,5060	0,4964	0,4760
NOx emission in % of mass flow	Port injection	0,00474017	0,00000367	0,00000511
	Direct injection	0,00474017	0,000003704	0,000005336

Table 6 Comparison of few parameters at 0, 30 and 100% of water injection

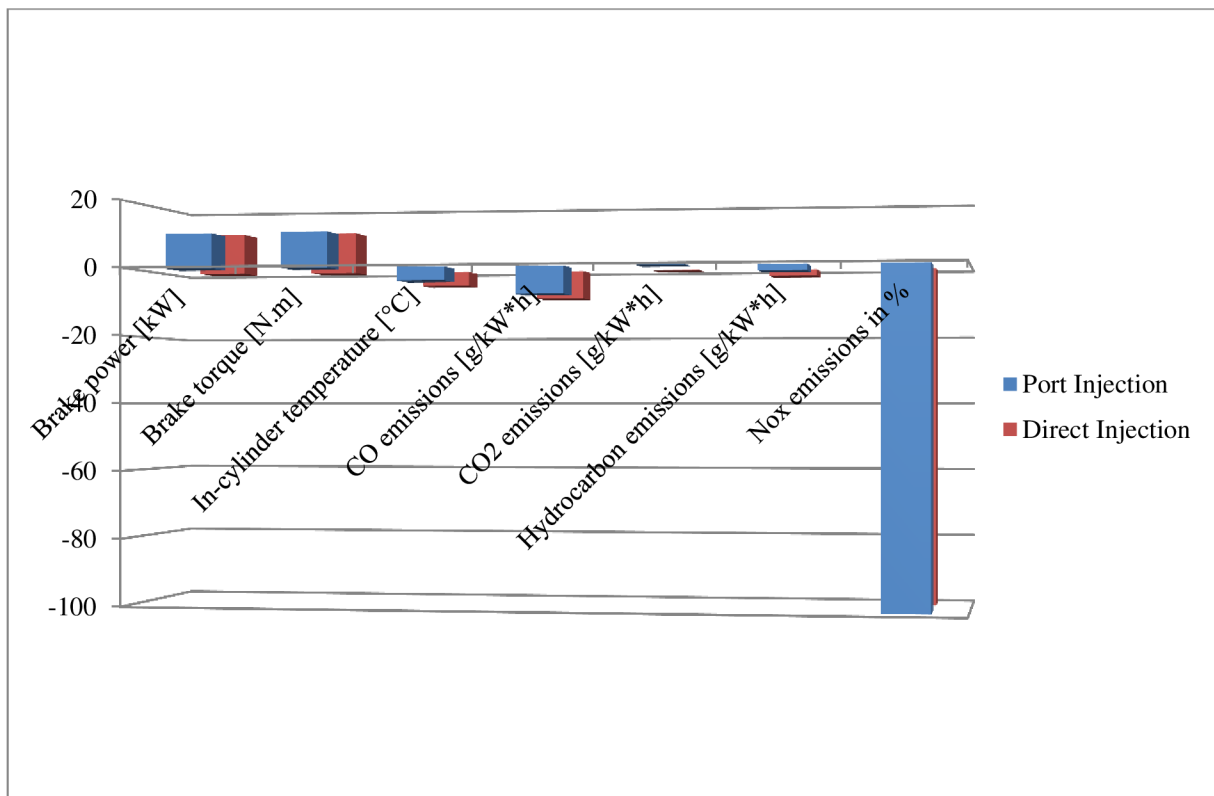

Figure 29 Comparison of Port and Direct water injection with 30% of water, level of 0% water is at 0

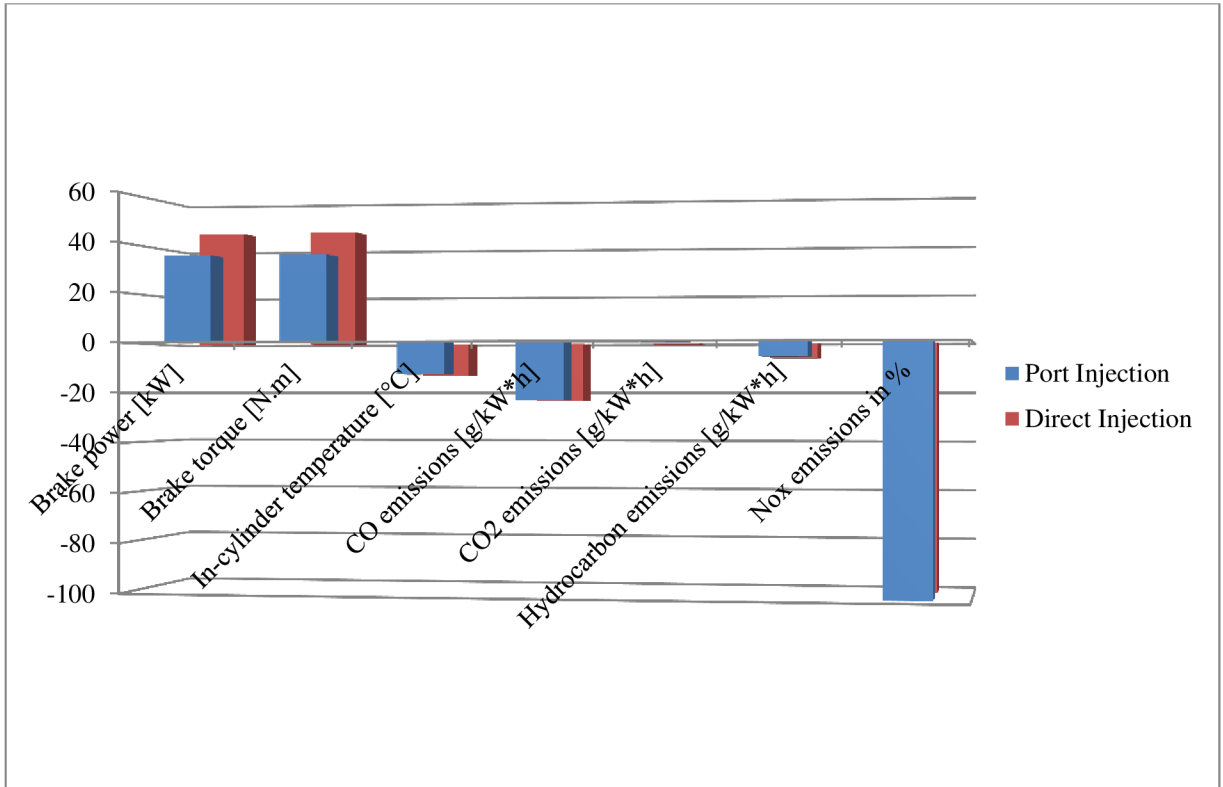

Figure 30 Comparison of Port and Direct water injection with 100% of water, level of 0% water is at 0

CONCLUSION

The main goal of my work was to approach the issue of technology that injects water into fuel and air mixtures. Technology has been rooted in the early part of the century, when injection of water / methanol mixtures was used in combat aircraft engines to short-term power uptake on take-offs from short runways. Thus equipped airplanes were additionally modified and this often reduced the life of the engine.

Later, technology returned to automotive. Many car makers have developed an attempt to bring water injection into life in an attempt to increase the engine cooling rate. This increased the compression ratio and thus performance. However, only a few projects went into mass production, such as the Oldsmobile F-85 Jetfire or Saab 99 Turbo. Due to the poor care of the vehicles but also by the inadequate technology, water injection had a short history in common cars, but it was still used successfully in motor-sport.

In the recent past, technology has again come to the attention of the professional public, many research has been carried out on diesel or petrol engines. New research shows that with the right amount of liquid and system design, it is possible to achieve better results in terms of efficiency, emissions and lifetime of components. This aggregation adjustment can increase power by up to 10% while reducing consumption by 4.5%.

In my work, I developed a simulation in the GT-Power program, where I tried to verify the information I obtained. The simulations confirmed all aspects that are declared by research. Some results such as engine power and torque have shown an increase of up to 45%. These high differences can be eliminated by adapting the computational model to the real engine, but they are not unrealistic. Another significant improvement showed to be in NOX emissions. Water injection technology is a huge asset, especially in the era of extreme emission reductions that we are meeting today and certainly has a huge potential.

SOURCES

- [1] STONE, R. *Introduction to Internal Combustion Engines*. Fourth Edition. Basingstoke: Palgrave Macmillan, 2012. 516 s. ISBN 978-1-137-02829-5.
- [2] Étienne Lenoir BELGIAN INVENTOR. In: *Encyclopedia Britannica* [online]. Edinburgh, Scotland: Encyclopedia Britannica, 1998 [cit. 2018-01-30]. Available from: <https://www.britannica.com/biography/Etienne-Lenoir>
- [3] Nikolaus Otto GERMAN ENGINEER. In: *Encyclopedia Britannica* [online]. Edinburgh, Scotland: Encyclopedia Britannica, 1998 [cit. 2018-01-30]. Available from: <https://www.britannica.com/biography/Nikolaus-Otto>
- [4] QUATTROCHI, Douglas. : The Internal combustion engine (Otto Cycle). In: *MIT EDU* [online]. 2006, 2006-08-06 [cit. 2018-01-31]. Available from: <http://web.mit.edu/16.unified/www/SPRING/propulsion/notes/node25.html>
- [5] BELLIS, Mary. Who Invented the Car?: A Frenchmen Made the First Automobile, but Its Evolution Was a Worldwide Effort. In: *ThoughtCo*. [online]. November 21, 2017 [cit. 2018-02-01]. Available from: <https://www.thoughtco.com/who-invented-the-car-4059932>
- [6] DUNLAP, Charles R. and Harris D. HIMES. *Water injection system for an internal combustion engine*. 1972. United States of America. 268474. Patented Nov. 5, 1974. Filled July 3, 1972.
- [7] BABU, A. R., G. Amba Prasad RAO a T. Hari PRASAD. Direct injection of water mist in an intake manifold spark ignition engine. In: *International Journal of Automotive and Mechanical Engineering (IJAME)*. Universiti Malaysia Pahang: UMP, 2015, s. 2809-2819. DOI: <http://dx.doi.org/10.15282/ijame.12.2015.1.0236>. ISSN 2180-1606.
- [8] Zníži voda spotrebu paliva? BMW dokazuje, že sa to dá. Roman Mališka. [cit. 2018-02-18] <https://www.techpedia.sk/technologie-pre-ludi/novinky/automotive/2033/znizi-voda-spotrebu-paliva-bmw-dokazuje-ze-sa-to-da>
- [9] Boost Cooler Geschichte. [cit. 2018-02-22]. Dostupné z: <https://www.snowperformance.eu/de/wassereinspritzung/boost-cooler-geschichte>
- [10] Rowe, M, Ladd, G. Water injection for aircraft engines. SAE technical paper 460192, 1946. DOI: 10.4271/460192.
- [11] Yaws, CL. Thermophysical properties of chemicals and hydrocarbons. Norwich, NY: William Andrew Inc., 2008. [cit. 2018-02-22]. <http://journals.sagepub.com/doi/full/10.1177/1468087415599867>
- [12] HOPPE, Fabian et al. Water injection for gasoline engines: Potentials, challenges, and solutions. In: *International Journal of Engine Research* [online]. SAGE, 2016, s. 86-96 [cit. 2018-02-22]. DOI: 10.1177/1468087415599867. Available from: <http://journals.sagepub.com/doi/pdf/10.1177/1468087415599867>

- [13] AUTO NA VODU? MOŽNÁ ÚSPORA PALIVA AŽ 30-60%! [cit. 2018-02-22]. <<http://dolezite.sk/old/>
- [14] Zníži voda spotrebu paliva? BMW dokazuje, že sa to dá. [cit. 2018-02-22]. <https://www.techpedia.sk/technologie-pre-ludi/novinky/automotive/2033/znizi-voda-spotrebu-paliva-bmw-dokazuje-ze-sa-to-da>
- [15] *Assessing the impacts of selected options for regulating CO2 emissions from new passenger cars and vans after 2020* [online]. 19. 02. 2018, , 23 [cit. 2018-04-23]. Available from: https://ec.europa.eu/clima/sites/clima/files/transport/vehicles/docs/ldv_post_2_020_co2_en.pdf
- [16] WATER/METHANOL INJECTION AS A GAS-SAVER?. In: *Jalopy Journal* [online]. Emerald City, Seattle, 2012, Feb 10 2012 [cit. 2018-04-18]. Available from: <https://www.jalopyjournal.com/forum/threads/water-methanol-injection-as-a-gas-saver.670001/>
- [17] SGSASH. Knock Knock, Detonation Time. In: *On Point Dyno* [online]. January 2, 2015 [cit. 2018-04-18]. Available from: <https://www.onpointdyno.com/knock-knock-detonation-time/>
- [18] JESSUP, Ralph S. HEATS OF VAPORIZATION OF EIGHT GASOLINES. In: *Journal of Research of the National Bureau of Standards* [online]. Volume 15. Washington: U. S. DEPARTMENT OF COMMERCE, 1935, June 18, 1935, s. 232 [cit. 2018-04-26]. Available from: https://nvlpubs.nist.gov/nistpubs/jres/15/jresv15n3p227_A1b.pdf
- [19] *Fluids - Latent Heat of Evaporation* [online]. Engineering toolbox, 2003 [cit. 2018-05-01]. Available from: https://www.engineeringtoolbox.com/fluids-evaporation-latent-heat-d_147.html
- [20] ŠKORPÍK, Jiří. Tepelné oběhy a jejich realizace, *Transformační technologie*, 2006-11, [last updated 2018-01-17]. Brno: Jiří Škorpík, [on-line] pokračující zdroj, ISSN 1804-8293. Dostupné z <http://www.transformacni-technologie.cz/06.html>. English version: Heat cycles and their realizations. Web: http://www.transformacni-technologie.cz/en_06.html.
- [21] MINGRUI ET AL., Wei. Water injection for higher engine performance and lower emissions. In: *Journal of the Energy Institute* [online]. Published by Elsevier, 2016, 7 January 2016, s. 285-299 [cit. 2018-05-03]. ISSN 1743-9671.
- [22] LORD, Brad. *Boost Beginnings: The Turbo Jetfire* [online]. 9th June 2015 [cit. 2018-05-11]. Available from: <http://www.speedhunters.com/2015/06/oldsmobile-jetfire-turbo/>
- [23] BRUTT, Ryan. In: *Hot Rod Network* [online]. October 13, 2015 [cit. 2018-05-13]. Available from: <http://www.hotrod.com/articles/oldsmobiles-lost-turbo-v8-discovered-in-an-illinois-garage/>
- [24] COLE, Lance. *Saab 99 and 900: the complete story*. Ramsbury: Crowood, 2011. ISBN 978-184-7973-528.

- [25] MARTZ, Christophe. Water injection in Formula Renault 1. In: *Econologie* [online]. May 26 [cit. 2018-05-13]. Available from: <https://en.econologie.com/injection-water-in-formula-1-renault/>
- [26] *Renault RE40 1983 wallpapers* [online]. In: . [cit. 2018-05-14]. Available from: <https://www.favcars.com/renault-re40-1983-wallpapers-118440>
- [27] DUSIL, Tomáš. *Nový homologační emisní test WLTP: Opravdu znamená konec lhání?* [online]. 4.10.2017 [cit. 2018-05-15]. Available from: <http://www.auto.cz/wltp-novy-homologacni-emisni-test-110305>
- [28] DELPHI. *Worldwide Emissions Standards: Passenger Cars and Light Duty Vehicles* [online]. [cit. 2018-05-24]. Available from: <https://d2ou7ivda5raf2.cloudfront.net/sites/default/files/inline-files/2017%202018%20Worldwide%20Emissions%20Standards%20Passenger%20Cars%20Light%20Duty.pdf>
- [29] VIJAYENTHIRAN, Viknesh. *More automakers to adopt BMW M4 GTS water-injection system* [online]. Sep 2, 2016 [cit. 2018-05-16]. Available from: https://www.motorauthority.com/news/1105920_more-automakers-to-adopt-bmw-m4-gts-water-injection-system
- [30] COLLIE, Scott. *Bosch WaterBoost injection opens door to better power and economy* [online]. September 1st, 2016 [cit. 2018-05-17]. Available from: <https://newatlas.com/bosch-water-injection/45205/>
- [31] KASKO2GO. *What is knocking and detonation in the petrol and diesel engine?* [online]. [cit. 2018-05-17]. Available from: <https://www.quora.com/What-is-knocking-and-detonation-in-the-petrol-and-diesel-engine>
- [32] VIJAYENTHIRAN, Viknesh. *BMW Shows Off More Vehicles With Power-Boosting Water Injection* [online]. Jul 5, 2015 [cit. 2018-05-17]. Available from: https://www.motorauthority.com/news/1098979_bmw-shows-off-more-vehicles-with-power-boosting-water-injection#image=100517337

LIST OF ABBREVIATIONS AND SYMBOLS USED

C_2H_6O	[-]	Ethyl alcohol
CH_3OH	[-]	Methyl alcohol
CO_2	[-]	Carbon dioxide
C_p	$\left[\frac{J}{kg \cdot K}\right]$	Specific heat capacity
H_2O	[-]	Water
O_2	[-]	Oxygen
<i>ADI</i>	[-]	Anti-detonation injection
<i>CA</i>	[°]	Crank angle
<i>CO</i>	[-]	Carbon monoxide
<i>EGR</i>	[-]	Exhaust gas recirculation
<i>LCV</i>	[-]	Light Commercial Vehicles
<i>NEDC</i>	[-]	New European Driving Cycle
<i>NMHC</i>	[-]	Non-methane hydrocarbons
<i>NO_x</i>	[-]	Oxides of nitrogen
<i>PM</i>	[-]	Solid particles
<i>RDE</i>	[-]	Real Driving Emission
<i>TDC</i>	[-]	Top Dead Center
<i>THC</i>	[-]	Unburnt hydrocarbons
<i>WLTC</i>	[-]	World Harmonized Light Vehicle Duty Test Cycle
<i>WLTP</i>	[-]	World Harmonized Light Vehicle Duty Test Cycle
ΔH	$\left[\frac{J}{g}\right]$	Heat of vaporization