



Pedagogická
fakulta

Univerzita Palackého
v Olomouci

Palacký University Olomouc

Doctoral Dissertation

Science = Male, Arts = Female, but I am the Exception:
Studies on Gender Stereotypes of the Counter Subject Gender
Stereotypes College Students

Student: Chunyan Liu

Doctoral degree program: Education

Supervisor: Miroslav Chráska, Ph.D.

Form of study: Full-Time

Declaration of Originality

I hereby declare that this paper, titled "Science = Male, Arts = Female, but I am the Exception: Studies on Gender Stereotypes of the Counter Subject Gender Stereotypes College Students", is my own original work. I affirm that I have not plagiarized any part of this paper from other sources and that all sources used have been properly acknowledged.

I acknowledge that plagiarism is a serious academic offense and will not be tolerated. Therefore, I have taken all necessary steps to ensure that this paper is my own original work, and I have cited all sources used in accordance with the referencing style specified by my academic institution.

I confirm that no part of this paper has been previously submitted for assessment, and I understand that submitting work that is not my own original work may result in severe penalties.

Signature: *Chunyan Liu*

Date: 28.04.2023

Abstract

The current studies focus on gender stereotypes among counter subject gender stereotypes (CSGS) college students. Using direct and indirect measurement methods, the studies measured both the explicit and implicit gender stereotypes and math/language attitudes among 368 first-year students majoring in math and Chinese language and literature at Sichuan University of Science and Engineering, and compared them with subject gender stereotypes (SGS) college students. Additionally, the studies explored the relationship between explicit and implicit gender stereotypes, math/language attitudes, and math/English performance. The following conclusions were drawn:

- a) Apart from explicit subject gender stereotypes, there were no differences in other explicit or implicit gender stereotypes between CSGS and SGS college students. Notably, CSGS college students did not demonstrate greater identification with sex role egalitarianism compared to SGS college students. Overall, CSGS college students are not exceptional in terms of gender stereotypes and sex role egalitarianism compared to SGS college students, as there is more similarity than difference between the two groups.
- b) CSGS college students do exhibit differences from SGS college students with regard to their explicit attitudes towards math and language. Specifically, CSGS students hold more positive explicit attitudes towards both math and language in comparison to SGS students. However, there were no notable differences in implicit attitudes towards math and language between the two groups, as both shared negative implicit attitudes towards math and positive implicit attitudes towards language.
- c) Gender is a significant factor that influences gender stereotypes. Compared to male college students, female college students are less accepting of gender stereotypes and more accepting of sex role egalitarianism, although this difference is mainly manifested in explicit rather than implicit measurements.
- d) Explicit gender stereotypes and implicit gender stereotypes are linked yet distinct constructs.
- e) Gender stereotypes can indeed predict math/language attitude, and have a certain predictive ability.
- f) Gender stereotypes have a certain predictive power for the math performance of CSGS

college students, but not for their English performance.

g) Math/language attitudes may indeed be the mediating variables between gender stereotypes and math/English performance, but this possibility is not very high.

Keywords: Counter subject gender stereotypes college students; Direct measurement; Indirect measurement; IAT; Explicit gender stereotypes; Implicit gender stereotypes; Explicit math/language attitudes; Implicit math/language attitudes; College entrance examination math performance; College entrance examination English performance.

Catalogue

1. Introduction	1
2. Review	3
2.1. Stereotypes	3
2.1.1. Definition of stereotypes	3
2.1.2. Categorization of Stereotypes	4
2.1.2.1. Categorization by content	4
2.1.2.2. Categorization by measurement method	5
2.2. Gender stereotypes	6
2.2.1. Definition of gender stereotypes	6
2.2.2. Structure of gender stereotypes	6
2.2.2.1. Two-factor model	7
2.2.2.2. Four-factor model	7
2.2.2.3. Two-layer six-factor model	8
2.2.3. Categorization of gender stereotypes	8
2.2.3.1. Categorization by function	8
2.2.3.2. Categorization by content	9
2.2.3.3. Categorization by measurement method	10
2.2.4. Measurement of gender stereotypes	10
2.2.4.1. Direct measurement	10
2.2.4.1.1. Scales	10
2.2.4.1.2. Typical feature assignment method	11
2.2.4.1.3. Free response method	11
2.2.4.2. Indirect measurement	11
2.2.4.2.1. Latency-based paradigm	12
2.2.4.2.1.1. The procedure of IAT	12
2.2.4.2.1.2. Basic principle of IAT	15
2.2.4.2.1.3. Calculation of IAT effect	17
2.2.4.2.1.4. Reliability and validity of IAT	18
2.2.4.2.2. Stereotypic explanatory bias	20
2.3. Gender stereotypes of college students	22
2.3.1. Trait gender stereotypes of college students	22
2.3.1.1. What are the typical trait gender stereotypes that exist among college students?	22
2.3.1.2. Do college students' trait gender stereotypes change with the times?	24
2.3.2. Subject gender stereotypes of college students	25
2.3.3. Math gender stereotypes of college students	27
2.3.4. Language gender stereotypes of college students	29

2.4. Counter gender Stereotypes	29
3. Research Ideas	32
3.1. Basis for establishment of the present studies	32
3.1.1. Limitations of previous studies	32
3.1.1.1. Limitations of research objects	32
3.1.1.2. Limitations of research content	32
3.1.1.3. Limitations of research methods	32
3.1.1.4. Limitations of theoretical construction	33
3.1.2. Improvement in present studies	34
3.1.2.1. Improvement in research object	34
3.1.2.2. Improvement in research content	34
3.1.2.3. Improvement in research methods	34
3.1.2.4. Improvement in theoretical construction	35
3.2. Research design	35
3.2.1. Research purpose	35
3.2.2. Research participants	35
3.2.3. Research questions	36
3.2.4. Research technology route	37
3.2.5. Research hypothesis	37
3.2.6. Research instruments	40
3.2.6.1. Scales	40
3.2.6.1.1. Explicit trait gender stereotypes scale	40
3.2.6.1.2. Sex role egalitarianism scale-BB(SRES-BB)	40
3.2.6.1.3. Explicit subject gender stereotypes scale (ESGS)	41
3.2.6.1.4. Explicit math gender stereotypes scale (EMGS)	42
3.2.6.1.5. Explicit language gender stereotypes scale (ELGS)	42
3.2.6.1.6. Explicit math attitude scale (EMA)	43
3.2.6.1.7. Explicit language attitude scale (ELA)	43
3.2.6.2. Implicit association test	43
3.2.6.2.1. Target category, attribute category and item design of IAT	43
3.2.6.2.2. Tasks of 7 blocks in IAT	45
3.2.6.2.3. Balance of 7 block sequences in IAT	45
3.2.6.2.4. Trial times design of each block of IAT	46
3.2.6.2.5. Sequential balance of four IAT	46
3.2.6.2.6. Process of IAT	47
3.2.6.2.7. IAT equipment and environment	49
3.2.7. Data processing	49

3.2.8. Expected results	49
3.2.9. Significance of the present studies	49
3.2.9.1. Theoretical significance	49
3.2.10. Practical significance	51
4. The Explicit Gender Stereotypes and Sex Role Egalitarianism of CSGS College Students	54
4.1. Research purpose	54
4.2. Research hypothesis	54
4.3. Participants	54
4.4. Instruments	54
4.5. Research procedure	55
4.6. Data processing	55
4.7. Results	55
4.7.1. Descriptive statistics for each explicit scale	55
4.7.2. Explicit trait gender stereotypes of the CSGS college students	55
4.7.2.1. Explicit male trait gender stereotypes of the CSGS college students	56
4.7.2.2. Explicit female trait gender stereotypes of the CSGS college students	57
4.7.3. Sex role egalitarianism of the CSGS college students	58
4.7.3.1. Comparison of SRES-BB between the CSGS and the SGS college students	58
4.7.3.2. One-sample t-test of SRES-BB and its factors	59
4.7.3.3. Influence of various variables on SRES-BB	59
4.7.3.4. Further exploration of the influence of sex and major on SRES-BB	61
4.7.4. Explicit subject gender stereotypes of the CSGS college students	63
4.7.4.1. Comparison of explicit subject gender stereotypes between the CSGS and the SGS college students	63
4.7.4.2. One-sample t-test of explicit subject gender stereotypes and its sub-scales	65
4.7.4.3. Influence of various variables on ESGS index	66
4.7.4.4. Further exploration of the influence of sex and major on ESGS index	67
4.7.5. Explicit math gender stereotypes of the CSGS college students	69
4.7.5.1. Comparison of explicit math gender stereotypes between the CSGS and the SGS college students	69
4.7.5.2. Influence of various variables on explicit math gender stereotypes	70
4.7.5.3. Further exploration of the influence of sex and major on explicit math gender stereotypes	72
4.7.6. Explicit language gender stereotypes of the CSGS college students	74
4.7.6.1. Comparison of explicit language gender stereotypes between the CSGS and the SGS college students	74
4.7.6.2. Influence of various variables on explicit language gender stereotypes	75

4.7.6.3. Further exploration of the influence of sex and major on explicit language gender stereotypes	77
4.8. Discussion	79
4.8.1. Explicit trait gender stereotypes of the CSGS college students	79
4.8.2. Sex role egalitarianism of the CSGS college students	81
4.8.3. Explicit subject gender stereotypes of the CSGS college students	83
4.8.4. Explicit math gender stereotypes of the CSGS college students	84
4.8.5. Explicit language gender stereotypes of the CSGS college students	85
4.9. Conclusion	86
5. The Implicit Gender Stereotypes of the CSGS College Students	88
5.1. Research purpose	88
5.2. Research hypothesis	88
5.3. Participants	88
5.4. Instruments	89
5.5. Research procedure	89
5.5.1. Procedure of IAT1	89
5.5.2. Procedure of IAT2	91
5.5.3. Procedure of IAT3	92
5.6. Data processing	92
5.7. Results	92
5.7.1. Descriptive statistics for IAT1, IAT2 and IAT3	92
5.7.2. Implicit trait gender stereotypes of the CSGS college students	93
5.7.2.1. Comparison of implicit trait gender stereotypes between the CSGS and the SGS college students	93
5.7.2.2. Influence of various variables on implicit trait gender stereotypes	94
5.7.2.3. Further exploration of the influence of sex and major on implicit trait gender stereotypes	95
5.7.3. Implicit subject gender stereotypes of the CSGS college students	97
5.7.3.1. Comparison of implicit subject stereotypes between the CSGS and the SGS college students	97
5.7.3.2. Influence of various variables on implicit subject gender stereotypes	98
5.7.3.3. Further exploration of the influence of sex and major on implicit subject gender stereotypes	100
5.7.4. Implicit math/language gender stereotypes of the CSGS college students	101
5.7.4.1. Comparison of implicit math/language stereotypes between the CSGS and the SGS college students	101
5.7.4.2. Influence of various variables on implicit math/language gender stereotypes	102

5.7.4.3. Further exploration of the influence of sex and major on implicit math/language gender stereotypes	103
5.8. Discussion	104
5.8.1. Implicit trait gender stereotypes of the CSGS college students	104
5.8.2. Implicit subject gender stereotypes of the CSGS college students	105
5.8.3. Implicit math/language gender stereotypes of the CSGS college students	106
5.9. Conclusion	107
6. The Relationship between Implicit and Explicit Gender Stereotypes of the CSGS College Students	108
6.1. Research purpose	108
6.2. Research hypothesis	108
6.3. Participants	108
6.4. Instruments	108
6.5. Research procedure	108
6.6. Data processing	108
6.7. Results	109
6.7.1. Correlation analysis of explicit and implicit gender stereotypes	109
6.7.2. Exploratory factor analysis of explicit and implicit gender stereotypes	111
6.7.3. Confirmatory factor analysis of explicit and implicit gender stereotypes	113
6.8. Discussion	115
6.8.1. The relationship between implicit and explicit gender stereotypes	115
6.8.2. The experimental dissociation of explicit and implicit gender stereotypes	118
6.9. Conclusion	120
7. Math/Language Attitudes of the CSGS College Students and Their Relationship with Gender Stereotypes	121
7.1. Research purpose	121
7.2. Research hypothesis	121
7.3. Participants	121
7.4. Instruments	121
7.5. Research procedure	122
7.6. Data processing	122
7.7. Results	122
7.7.1. Descriptive statistics of explicit and implicit math/language attitudes	122
7.7.2. Explicit math attitude of the CSGS college students	123
7.7.2.1. Comparison of explicit math attitude between CSGS and SGS college students	123
7.7.2.2. Influence of various variables on explicit math attitude	124
7.7.2.3. Further exploration of the Influence of sex and major on explicit math attitude	126

7.7.3. Explicit language attitude of the CSGS college students	128
7.7.3.1. Comparison of explicit language attitude between the CSGS and the SGS college students	128
7.7.3.2. Impact of various variables on explicit language attitude	129
7.7.3.3. Further exploration of the influence of sex and major on explicit language attitude .	131
7.7.4. Implicit math/language attitudes of the CSGS college students	133
7.7.4.1. Comparison of IAT4 between the CSGS and the SGS college students	133
7.7.4.2. Impact of various variables on implicit math/language attitudes	133
7.7.4.3. Further exploration of the influence of sex and major on implicit math/language attitudes	135
7.7.5. The relationship between gender stereotypes and math/language attitudes	136
7.7.5.1. Correlation analysis between gender stereotypes and math/language attitudes of the CSGS college students.	136
7.7.5.2. Multiple linear regression of gender stereotypes on math/language attitudes of the CSGS college students	137
7.8. Discussion	139
7.8.1. Positive explicit math and language attitudes of college Students	139
7.8.2. College students' generally negative implicit attitudes towards math	140
7.8.3. The predictive effect of explicit and implicit gender stereotypes on math/language attitudes	141
7.9. Conclusion	141
8. The Relationship between Gender Stereotypes and Math/English Performance of the CSGS College Students	143
8.1. Research purpose	143
8.2. Research hypothesis	143
8.3. Participants	143
8.4. Instruments	143
8.5. Research procedure	143
8.6. Data processing	143
8.7. Results	143
8.7.1. The relationship between gender stereotypes and math/English performance of the CSGS college students	144
8.7.1.1. Correlation analysis between gender stereotypes and math/English performance of the CSGS college students	144
8.7.1.2. Multiple linear regression of gender stereotypes on math performance of the CSGS college student	144
8.7.1.3. Multiple linear regression of gender stereotypes on English performance of the CSGS	

college student	145
8.7.2. The relationship between gender stereotypes and math/English performance of male college students	146
8.7.2.1. Correlation analysis between gender stereotypes and math/English performance of male college students	146
8.7.2.2. Multiple linear regression of gender stereotypes on math performance of male college student	146
8.7.2.3. Multiple linear regression of gender stereotypes on English performance of male college student	147
8.7.3. The relationship between gender stereotypes and math/English performance of female college students	147
8.7.3.1. Correlation analysis between gender stereotypes and math/English performance of female college students	147
8.7.3.2. Multiple linear regression of gender stereotypes on math performance of female college student	148
8.7.3.3. Multiple linear regression of gender stereotypes on English performance of male college student	148
8.8. Discussion	149
8.8.1. Correlation between explicit/implicit gender stereotypes and math/English performance	149
8.8.2. The predictive power of explicit/implicit gender stereotypes on math/English performance	150
8.9. Conclusion	151
9. The Role of Math/Language Attitudes in the Relationship between Gender Stereotypes and Math/English Performance	152
9.1. Research purpose	152
9.2. Research hypothesis	152
9.3. Participants	152
9.4. Instruments	152
9.5. Research procedure	152
9.6. Data processing	152
9.7. Results	154
9.7.1. The mediating role of explicit math attitudes between explicit math gender stereotypes and math/English performance of the CSGS college students	154
9.7.1.1. The mediating role of explicit math attitudes between explicit math gender stereotypes and math performance of the CSGS college students	154
9.7.1.2. The mediating role of explicit language attitudes between explicit language gender stereotypes and English performance of the CSGS college students	156

9.7.2. The mediating role of implicit math/language attitudes between implicit math/language gender stereotypes and math/English performance of the CSGS college students	157
9.7.2.1. The mediating role of implicit math/language attitudes between implicit math/language gender stereotypes and math performance of the CSGS college students	157
9.7.2.2. The mediating role of implicit math/language attitudes between implicit math/language gender stereotypes and English performance of the CSGS college students ..	158
9.7.3. The mediating role of explicit math attitudes between implicit trait gender stereotypes and math/English performance of the CSGS college students	160
9.7.3.1. The mediating role of explicit math attitudes between implicit trait gender stereotypes and math performance of the CSGS college students	160
9.7.3.2. The mediating role of explicit language attitudes between implicit trait gender stereotypes and English performance of the CSGS college students	161
9.8. Discussion	162
9.9. Conclusion	164
10. General Discussion	165
10.1. Are CSGS college students really the exception?	165
10.2. What is unique about CSGS college students?	165
10.3. Which factor is more important in influencing gender stereotypes?	166
10.4. Who are the most revolutionary college students in the gender field?	167
10.5. What is the relationship between explicit gender stereotypes and implicit gender stereotypes?	167
10.6. What is the predictive power of gender stereotypes on math/language attitudes?	168
10.7. What is the predictive power of gender stereotypes on math/English performance?	168
10.8. Does the mediating effect of math/language attitudes hold true?	169
11. General Conclusion	169
References	171
Appendix	179
I. Instruction and demographic information	179
III. Sex Role Egalitarianism Scale-BB(SRES-BB)	179
IV. Explicit Subject Gender Stereotypes Scale	180
V. Explicit Math Gender Stereotypes Scale	181
VI. Explicit Language Gender Stereotypes Scale	181
VII. Explicit Math Attitude Scale	182
VIII. Explicit Language Attitude Scale	182
IX. Target categories, attribute categories and items of four IAT	183
X. The actual instructions displayed on computer screen for IAT1	184
XI. The actual pages on computer screen for core experimental procedure of B1	185

XII. Photos of the research process	186
Acknowledgment	187

1. Introduction

Since ancient times in China, there has been a belief that male and female are inherently different and should be treated as such. Despite national policies promoting gender equality, many views perpetuate gender differences. One such view is the stereotypes that males are better suitable for learning science, while females are better suitable for learning arts. This stereotype falls under the category of gender stereotypes, specifically subject gender stereotypes. These gender stereotypes are prevalent not only in society but also among teachers, parents, and even students themselves.

There is no denying that Chinese universities show a noticeable gender imbalance in terms of the distribution of majors, with a much higher proportion of male college students majoring in science and engineering compared to their female counterparts, while a much larger proportion of female students choose to major in liberal arts compared to male students. Female college students who choose science and engineering majors, like male college students who choose liberal arts majors, are a minority. However, their presence on campus cannot be ignored. By choosing majors that are diametrically opposed to the prevailing subject gender stereotypes, they challenge and subvert them. For this reason, I refer to them as counter subject gender stereotypes (CSGS) college students, namely, female in science and male in liberal arts. Conversely, those college students who choose majors consistent with subject gender stereotypes are referred to as subject gender stereotypes (SGS) college students, namely, men in science and women in liberal arts. While admiring the CSGS college students' courage in challenging gender stereotypes, interesting questions arise: do these students agree with the stereotypes that males are better suitable for learning science, while females are better suitable for learning arts?

To gain a preliminary understanding of this issue, I conducted interviews with two female college students majoring in math and two male college students majoring in Chinese language and literature at Sichuan University of Science and Engineering in China. All participants had attended my mental health education course for college students, and I recruited them to participate voluntarily in the current study, which was conducted through We Chat. The following is an excerpt from the interview:

Interviewer: Is the notion that boys are better suited for science and engineering, while

girls are better suited for liberal arts, prevalent in society and on campus? Have you heard of it?

Interviewee: Yes, I have heard of it.

Interviewer: Do many people around you agree with this statement?

Interviewee: There are likely many who agree with this view.

Interviewer: Are you not influenced by this statement?

Interviewee: No, not at all.

Interviewer: Do you agree that boys are more suited for science and engineering, while girls are more suited for liberal arts?

Interviewee: I am an exception. I do not agree with this statement. I believe that one's interest and personality, rather than gender, determine the most appropriate field of study.

These CSGS college students acknowledged that the stereotypes that males are better suitable for science, while females are better suitable for arts is widespread on campus. However, they were not influenced by this stereotype and chose their majors based on their professional interests and personality. Furthermore, they expressed disagreement with gender-based stereotypes.

This study's findings, based on a small-scale online interview conducted through We Chat, are not conclusive. As a unique population, do CSGS college students share the stereotypes that males are better suitable for science, while females are better suitable for arts? Are they truly an exception, as they claim? What are their attitudes toward gender equality? What are their attitudes toward math and language? Is their performance in math and language impacted by gender stereotypes in these subjects? These questions pique my curiosity, and I am eager to discover the answers.

2. Review

2.1. Stereotypes

2.1.1. Definition of stereotypes

Stereotypes were originally a term in the field of printing in the West, referring to a kind of printing plate developed in the late 18th century(Encyclopedia Britannica). In 1922, Walter Lippmann, a famous American news commentator, published his work "*Public Opinion*", which is a classic book in the field of journalism examining the formation and influencing factors of public opinion. The third part of the book is called "Stereotypes". In this part, Lippmann borrowed the word "stereotypes" for the first time to express a human perception mode. Before considering the information that humans are aware of, stereotypes impose certain properties on the information, characterized by being put into use before rationality. At the same time, he thought that although stereotypes would certainly be separated from the facts to a certain extent, they were still very stubborn and difficult to correct for two reasons: first, they could save our energy, and second, they could protect our social order (Lippmann, 2010). As a result, the term "stereotypes" has a new meaning, which extends from a printing term to a journalism, sociology, and psychology term and is widely accepted. The definition of stereotypes has received attention.

The term "stereotypes" belong to the field of psychology, which is defined as "a fixed, oversimplified, and often biased belief about a group of people " and " typically rationally unsupported generalizations, and, once a person becomes accustomed to stereotypical thinking, he or she may not be able to see individuals for who they are" (Encyclopedia Britannica). The *Comprehensive Dictionary of Psychology*, compiled by Chinese psychologists, defined stereotypes as a relatively fixed, simplified and overly general view of a group or group of people("Stereotypes," 2003). There is little disagreement among psychologists regarding stereotypes. If there is any difference, it lies only in some psychologists emphasizing the shared nature of stereotypes among members of society(Greenwald & Banaji, 1995), while others specifically point out that stereotypes come from the definitions in the mind rather than reality(Katz & Braly, 1935).

In general, academic researchers have a relatively consistent definition of stereotypes with little disagreement. They view stereotypes as a simplified and fixed perception of the

characteristics of members of a certain group that is widely held in society. The characteristics of simplification and fixation associated with stereotypes may not be applicable to individuals within groups. For a long time, researchers considered stereotypes as a specific instance of a more general cognitive process, and they conceptualized it as a negative judgment that deviates from the true state. However, researchers now take a more neutral stance, emphasizing the process and content of stereotyping rather than its "rightness" or "wrongness"(Deaux & Lewis, 1984).

2.1.2. Categorization of Stereotypes

2.1.2.1. Categorization by content

Stereotypes can be categorized into various types based on their content, such as age stereotypes, gender stereotypes, national stereotypes, occupational stereotypes, regional stereotypes, and more.

Age stereotypes refer to fixed and simplistic views that people hold about individuals of different ages. For instance, the stereotypes associated with elderly people suggest that they have low physical abilities and cognitive capacity, but they are often portrayed as enthusiastic, conversely, stereotypes of young people tend to be the opposite(Zuo, 2015).

Gender stereotypes refer to fixed and stereotyped views that people hold about males and females with regard to personality characteristics, behavior patterns, and occupations. For instance, there is a general belief that males are more rational, adventurous, active, and strong, and are thus suited for professions such as scientific research, engineering, and law enforcement. Conversely, females are often perceived as emotional, gentle, timid, and fragile, and are therefore considered suitable for professions such as teaching, waitressing, and secretarial work.

National stereotypes are a fixed and general view of the citizens of a country. Katz and Braly (1933) conducted a study on the stereotypes held by 100 Princeton University students about the people of 10 different countries or nationalities. They found that the students generally believed that Germans were characterized by a scientific mind, Italians were artistic, Blacks were superstitious, Irish were aggressive, British were athletic, and Jews were shrewd.

Occupational stereotypes refer to fixed impressions formed about people engaged in a certain occupation. For example, farmers are considered to be simple, hardworking, and uneducated;

entrepreneurs are thought to be shrewd, bold, and selfless; and engineers are considered to be meticulous, rigorous, and dull(Zuo & Wen, 2011).

Regional stereotypes are a type of stereotype that refers to the internal cognitive structures of individuals' beliefs, expectations, and attitudes toward people from a specific geographic region. For instance, a study found that Hong Kong participants' stereotypes of people from mainland China can be summarized as "ability", "morality" and "enthusiasm" while mainland participants' stereotypes of Hong Kong people can be summarized as "values", "enthusiasm" and "ability"(Zhao & Zheng, 2016).

Clearly, the aforementioned stereotypes are only a few examples of the many that exist in academic research, and not an exhaustive list. Age, region, nationality, and gender are commonly used criteria for categorizing people. Based on these criteria, individuals are placed into different groups such as the elderly and the young, Americans and Chinese, men and women, and so on. Whenever people can be classified according to different standards to form different groups, it is possible for individuals to hold a simplistic and unchanging view of these groups in order to conserve mental resources.

2.1.2.2. Categorization by measurement method

Stereotypes can be classified into explicit stereotypes and implicit stereotypes based on the method of measurement.

Explicit stereotypes are stereotypes obtained through direct measurement. Direct measurement involves using various scales, such as semantic differentiation scales and Likert scales, to directly measure participants' beliefs and attitudes. Participants are asked to rate several statements included in the scale based on whether they align with their own beliefs and attitudes or to what extent they agree with them. This is a dominant measurement method in psychology and pedagogy. However, it should be noted that the stereotypes obtained through direct measurement are the result of conscious and even deliberate thinking of individuals. They fall under the category of self-report, assuming that the participants can accurately introspect (Greenwald, 1990). Therefore, it is a common but inaccurate view that explicit stereotypes are purely conscious.

Implicit stereotypes are stereotypes that are measured indirectly. In this type of measurement, participants are put in a situation where they have to respond to an object, and their attitude

towards a certain attribute of the object will influence their response. Participants are not informed about what is being evaluated or asked to report on it, which helps to avoid demand characteristics and self-presentation artifacts (Greenwald, 1990; Greenwald & Banaji, 1995). In short, implicit stereotypes refer to the traces that usually cannot be identified or accurately identified from past experiences, and they have a significant impact on the quality attribution of members of a certain social category (Greenwald & Banaji, 1995). Implicit stereotypes are generally believed to be unconscious compared to explicit stereotypes.

2.2. Gender stereotypes

2.2.1. Definition of gender stereotypes

Assuming that stereotypes are generalizations applied to individuals based on their group membership, gender stereotypes can be described as "generalizations about the characteristics of men and women" (Heilman, 2012). Charlesworth and Banaji (2022) considered that gender stereotypes are "collective representations that link gender groups with roles or attributes", such as "career/family" and "science/arts". In contrast, Castaño et al. (2019) believed that "gender stereotypes refer to the historical gender and role division traditionally assigned in the work setting, and it could be the basis for both individual biased decisions and for discrimination in the organizations", and also believed "these beliefs reflect more generalizations than individual qualities".

Chinese researchers have also defined gender stereotypes. Xu (2003) regarded gender stereotypes as widely accepted fixed faith on male and female in social life. Individual's views on what typical men and women look like will affect their awareness and cause deviations in evaluating others' behavior. Another Chinese researcher, Song (2014), believed that gender stereotypes generally refer to various impressions and beliefs about men and women.

It is evident that various researchers share a similar definition of gender stereotypes. Gender stereotypes are defined as assumptions about the traits and behaviors of individuals that are based solely on their gender, and these assumptions are typically applied to all members of a particular gender group, without regard to individual differences. Such stereotypes involve making generalizations about men and women that may not accurately reflect the unique qualities and experiences of each individual.

2.2.2. Structure of gender stereotypes

Initially, while gender stereotypes were frequently referenced as causes and outcomes of various events, its internal structure were not clear to researchers. However, researchers gradually began to concentrate on this issue and proposed a series of models, including the two-factor model, the four-factor model, and the two-layer six-factor model.

2.2.2.1. Two-factor model

Some researchers have identified two sets of traits, namely warmth/expressiveness and competence/rationality, that are associated with women and men. The former is believed to be more characteristic of women than men, while the latter is believed to be more characteristic of men than women (Broverman et al., 1972; Rosenkrantz et al., 1968). Similarly, Fiske et al. (1999) and Fiske et al. (2002) also proposed the stereotype content model (SCM), which put forward that stereotypes result from interpersonal and inter-group interactions, and are captured by two dimensions: warmth and competence. When people encounter others, they want to know their intent and capability, which correspond to perceptions of warmth and competence, respectively. According to SCM, gender stereotypes also revolve around the same dimensions, with competence being commonly attributed to male and warmth to female, which is a common gender stereotype.

In conclusion, the structure of the two-factor models proposed by various researchers, whether it is warmth/expressiveness versus competence/rationality or warmth versus competence, have similarities. The association of male with ability and female with emotion is a common gender stereotype, and ability and warmth become two significant factors of gender stereotypes. The two-factor model's advantage is its simplicity and generality; however, this also means its disadvantage is its inability to comprehensively describe gender stereotypes. Furthermore, it is worth mentioning that the two-factor model primarily focuses on the personality traits of men and women only, which will undoubtedly be recognized by other researchers in due course.

2.2.2.2. Four-factor model

Indeed, researchers soon noticed the limitations of the two factor-model and expressed dissatisfaction with it. Deaux and Lewis (1983) argued that previous models focused solely on personality traits as the key elements of gender stereotypes, neglecting the multiple components that shape our conceptions of masculinity and femininity. They identified four elements of gender stereotypes: traits, role behaviors, physical appearance, and occupations,

each with masculine and feminine versions. While these ingredients are not exclusive to either sex, they are more strongly associated with one gender than the other. The researchers proposed that these four factors should be regarded as independent but related, such that information about one component influences judgments about the others. For instance, exposure to role behavior information can shape estimates of traits, and vice versa. The researchers also prompted that physical appearance was the most critical element of gender stereotypes (Deaux & Lewis, 1984).

This four-factor model provides a more extensive understanding of the internal structure of gender stereotypes. However, researchers continued to seek a comprehensive understanding of the structure of gender stereotypes beyond the four-factor model.

2.2.2.3. Two-layer six-factor model

Building upon the four factor-model of gender stereotypes (Deaux & Lewis, 1983, 1984) and SCM (Fiske et al., 2002; Fiske et al., 1999), Zuo (2015) proposed a two-layer six-factor model of gender stereotypes, including traits (ability and enthusiasm), role behaviors, occupations, and physical appearance. This model represents a synthesis of the two-factor and four-factor models, providing a more comprehensive and specific understanding of gender stereotypes.

Overall, the evolution of gender stereotype models has demonstrated a trend towards including more factors. While the two-factor model is the most general, the two-layer six-factor model likely has the greatest explanatory power. However, a good model must balance generality with explanatory power, and further research is needed to determine which model best fits this criterion.

2.2.3. Categorization of gender stereotypes

2.2.3.1. Categorization by function

Gender stereotypes serve both descriptive and prescriptive functions (Burgess & Borgida, 1999; Koenig, 2018). Descriptive gender stereotypes outline the attributes that are believed to be associated with women and men, such as women being emotional and men being rational. On the contrary, prescriptive gender stereotypes dictate how men and women should behave according to normative expectations, leading to negative consequences for those who deviate from these norms, particularly women. It is worth noting that the two categories are not always distinct, as descriptive stereotypes may also have prescriptive functions, and prescriptive

stereotypes may use descriptive stereotypes to justify their legitimacy. Moreover, research has demonstrated that gender stereotypes, regardless of whether they are descriptive or prescriptive, can hinder career advancement(Heilman, 2012).

2.2.3.2. Categorization by content

Based on the content, gender stereotypes can be classified into various types such as occupational gender stereotypes, subject gender stereotypes, mathematical gender stereotypes, language gender stereotypes, and sports gender stereotypes, among others. These types represent different aspects or branches of gender stereotypes.

It is commonly believed that gender is associated with occupational orientation, which leads to the generation of occupational gender stereotypes(Hu, 2005). In China, the occupational gender stereotypes that men are more adequate for professional and technical work, while women are more adequate for service work, have been entrenched in people's minds for a long time(Yu, 2003).

Similarly, people also associate gender with academic subjects, resulting in the formation of subject gender stereotypes. Subject gender stereotypes refer to the notion that males are better at learning science and engineering than females(Song et al., 2012), or that male are good at learning science and engineering majors and female are more suitable for learning arts and history majors(He & Liu, 2007).These subject gender stereotypes are not unique to China but are also present in other countries and regions. Whitehead (1996) conducted a study examining how students' perceptions of school disciplines as either masculine or feminine were related to their faith about sex roles, traits, motivation, and subject choices in schools in England and Wales. The study illustrated that although the majority of learners believed that both sexes were equally capable of succeeding in most subjects, the sciences were typically viewed as more masculine while arts and languages were viewed as more feminine, confirming earlier research on subject perceptions.

Math and language gender stereotypes are specific examples of subject gender stereotypes, which pertain to the perception that males are naturally good at math while females excel in language-related subjects.

Sports gender stereotypes refer to the biased beliefs held by people about gender and sports. There are three main forms of sports gender stereotypes. Firstly, it is commonly perceived that

men have superior athletic talent and ability compared to women. Secondly, there is a notion that men are better suited to sports that require intense confrontation and high levels of competition, whereas women are more suited to sports that have lower intensity and highlight femininity. Finally, participation in sports can lead to the development of physical traits that are considered "masculine," causing women to worry about losing their feminine characteristics. This can be a major concern for many women who participate in sports, as they fear that building muscle mass may not align with their perceived female characteristics (Yang et al., 2016).

Trait gender stereotypes refer to the stereotypical views about the personality traits associated with males and females. The two-factor model, which highlights the importance of personality traits in gender stereotypes, is a classic example of this type of model. This model suggests that personality traits are at the heart of gender stereotypes, as people tend to associate certain traits with one gender or the other.

2.2.3.3. Categorization by measurement method

Gender stereotypes are a branch of stereotypes, and can be categorized into explicit gender stereotypes and implicit gender stereotypes according to measurement methods, similar to stereotypes. Explicit gender stereotypes are measured directly, while implicit gender stereotypes are measured indirectly.

2.2.4. Measurement of gender stereotypes

2.2.4.1. Direct measurement

There are various methods to directly measure gender stereotypes, which generally involve conscious self-reporting. Common direct measures of gender stereotypes include the following methods:

2.2.4.1.1. Scales

Common direct measurement methods of gender stereotypes include scales. Gender stereotypes scales can be in the form of Likert scales, semantic differential scales, or feeling thermometers, among others. For example, Liu and Zuo (2006) developed a gender stereotypes scale and used it to study the structure of adolescent gender stereotypes. Nosek et al. (2002) used semantic differential scales and feeling thermometers to measure subject gender stereotypes. The advantage of scales is that their results can be easily standardized for

statistical processing, while the disadvantage is that participants' responses are limited by the scale's design.

2.2.4.1.2. Typical feature assignment method

This method involves the researcher creating a list of features beforehand, and the participants selecting the words that best match the characteristics of a certain group on the feature list. This method was first proposed by Katz and Braly (1933), who asked 100 students at Princeton University to select the words that best represent Germans, Italians, Chinese, etc. from a list of 84 adjectives prepared in advance in order to identify universal stereotypes. Later, this method was widely used in research. Similar studies have been conducted in China, where Qin and Yu (2001) selected 100 personality adjectives from the College Student Sex Role Inventory (CSRI) and created two adjective checklists. They asked participants to select the seven personality characteristics that are most important to young men and women in contemporary society from the adjective checklists and rank them according to their perceived importance. The main limitation of this method is that the participants' choices are largely constrained by the feature list provided by the researchers.

2.2.4.1.3. Free response method

This method involves directly asking the participants about the characteristics of a certain group and allowing them to respond freely. For instance, the participants may be asked questions such as "What words do you think best describe the characteristics of men and women", "What are some common traits of Americans", or "List five words that best represent the characteristics of farmers". The biggest gain of this method is that the participants are not limited by the options provided by the researchers and can respond freely.

2.2.4.2. Indirect measurement

Previously, social behavior was often thought to be under conscious control, if not always deliberate. However, there is now substantial evidence supporting the idea that social behavior often performs in an implicit or unconscious manner. In light of this, Greenwald and Banaji (1995) proposed the concept of implicit social cognition, which mainly encompasses attitudes, stereotypes, and self-esteem. Building on this, Wilson et al. (2000) proposed the dual model of attitude, suggesting that there are implicit and explicit attitudes towards the same object. Implicit social cognition cannot be measured directly but only through indirect measurement.

Therefore, indirect measurement is widely used, and stereotypes are no exception. Common indirect measures of gender stereotypes include the following methods.

2.2.4.2.1. Latency-based paradigm

Implicit cognition, including implicit stereotypes, is considered to be behavior or judgment that is automatically activated without conscious awareness of this causal relationship (Greenwald & Banaji, 1995). How can we effectively measure this? Greenwald et al. (1998) proposed the Implicit Association Test (IAT) to assess implicit attitudes by measuring potential automatic assessments. Later, the IAT has gradually become widely used in research, becoming one of the main methods to measure implicit social cognition, and has developed different variants, such as the extrinsic affect Simon task (EAST), the Go/No Go association test (GNAT), and others. The common point is that they are all latency-based paradigms, which are measurement methods based on latency. To measure implicit stereotypes in the current studies, the IAT will be used and highlighted below, while the other measures will not be further elaborated.

2.2.4.2.1.1. The procedure of IAT

In IAT, participants are required to categorize stimuli, such as pictures or words, presented on a computer monitor. This classification task is typically straightforward unless there are design errors. Participants must determine which category the stimulus belongs to and press the left or right key on the keyboard to respond. Throughout the process, the computer program records the latency between stimulus presentation and key pressing. This latency is crucial data in the IAT, and the assessment of stereotypes is based on latency duration. Greenwald et al. (1998) initially proposed a 5-step IAT procedure, but it was later replaced by the 7-step procedure, which is now considered the standard IAT procedure. Table1 provides a description of the 7-step IAT procedure.

To illustrate the procedure of the 7-step IAT, let us consider an example of measuring gender evaluation. The target categories consist of male and female, while the attribute categories comprise pleasant words and unpleasant words. Each category contains five items, as presented in Table2.

Table1 The standard order of 7 blocks

Block	Task
1	Classify the items (some pictures or words) for the two target categories (a pair of subjects whose implicit attitudes need to be measured, e.g., male/female, elderly/young).
2	Classify the items (some pictures or words) for the two attribute categories (a pair of concepts just opposite in attributes, e.g., pleasant words/unpleasant words).
3	Use the left and right key assignment in Block 1 and Block 2 to classify all four categories.
4	Repeat Block 3.
5	Classify the two target categories again, but revers the key arrangement of Block 1 and conduct more trials than in Block1.
6	Classify items for all four categories again, but the key arrangement of the target category is the same as that of Block 5.
7	Repeat Block 6.

Table2 Categories and items of IAT measuring gender evaluations

Category	Target		Attribute	
	Male	Female	Pleasant words	Unpleasant words
Items	Man	Women	Good	Bad
	Son	Daughter	Happy	Sad
	Father	Mothers	Joyful	Disgusting
	Husband	Wife	Beautiful	Ugly
	Boy	Girl	Loved	Scared

During Block 1 (B1), participants are presented with ten words representing male and female target categories. These stimuli are randomly exhibited on the computer screen, one at a time. When a male item is displayed, participants press the left key, while pressing the right key for a female item. In Block 2 (B2), participants are presented with pleasant and unpleasant attribute category words, also displayed randomly. Participants click the left key for pleasant

words and the right key for unpleasant words. In Block 3 (B3), participants engage in combined classification, with both target and attribute categories randomly presented on the screen. Participants press the left key for pleasant words or male items and the right key for unpleasant words or female items. This association of male with pleasant words and female with unpleasant words is consistent with people's more positive evaluation of males in daily life, making this block compatible. Block 4 (B4) repeats the process of B3. In Block 5 (B5), participants are asked to reclassify the two target categories and use new key pressing methods. This arrangement is the opposite of B1, with participants pressing the left key for female items and the right key for male items. Block 6 (B6) again involves combined classification. When female items or pleasant words are presented, participants press the left key, while pressing the right key for male items or unpleasant words. This block is considered incompatible as it associates female with pleasant words and male with unpleasant words, which is inconsistent with people's more positive evaluation of males. Block 7 (B7) repeats the process of B6. See Table3 for detailed process.

Table3 Sequence of blocks in the IAT measuring gender evaluations

Block	No.of trials	Function	Task	Items assigned to left-key response	Items assigned to right-key response
1	20	Practice	Initial target categories classification	Items of male	Items of female
2	20	Practice	Initial attribute categories classification	Pleasant words	Unpleasant words
3	20	Practice	Initial combined task(compatible)	Items of male Pleasant words	Items of female Unpleasant words
4	40	Test	Initial combined task(compatible)	Items of male Pleasant words	Items of female Unpleasant words
5	30	Practice	Reversed target categories classification	Items of female	Items of male
6	20	Practice	Reversed combined task(incompatible)	Items of female Pleasant words	Items of male Unpleasant words
7	40	Test	Reversed combined task(incompatible)	Items of female Pleasant words	Items of male Unpleasant words

Notes: Latency is defined as the time interval between the display of a stimulus and the participant's keystroke. Specifically, I will be focusing on the latency data from B3, B4, B6, and B7. A trial refers to the

smallest and repeatable experimental program that can be completed by a single stimulus unit. To ensure accurate analysis, I need to design a specific number of trials per block. The left and right keys on the keyboard can be used, with common options being E and I or D and J.

2.2.4.2.1.2. Basic principle of IAT

In the IAT, the latency of each trial is recorded as the time interval between stimulus presentation and the subject's keystroke, usually measured in milliseconds. The latency of each block is calculated as the average of all trials in the block. In the current studies, special attention will be paid to the latency data from B4 and B7. Specifically, when measuring gender evaluations, if the latency of B4 is less than that of B7, it suggests that men are more closely associated with pleasant words and women are more closely associated with unpleasant words, indicating a more positive implicit attitude towards males. Conversely, if the latency of B4 is greater than that of B7, it suggests a more positive implicit attitude towards females. There are various interpretations among researchers regarding this principle.

According to Houwer (2001), the IAT shares structural similarities with stimulus-response compatibility tasks. It is well-established that responses can be executed with greater speed and accuracy when they are similar to the presented stimuli compared to when they are dissimilar. The IAT leverages this concept by mapping two concepts onto a single response, which is easier to do when the two concepts are associated or similar in memory. When two categories require the same response key, the degree of similarity between the categories influences the performance on combined IAT tasks. The IAT effect is largely determined by the extent to which target and attribute categories exhibit similarities. Therefore, shorter latency between pleasant words+male items and unpleasant words+female items compared to pleasant words+female items and unpleasant words+male items suggests that male items and pleasant words are more closely related and similar, while female items and unpleasant words are more closely related and similar. This indicates a more positive implicit attitude towards males among the participants.

Cai (2003) believed that, in physiology, the IAT is grounded in the neural network model, which suggests that information is stored in a series of nodes and neural links that are hierarchically organized according to semantic relations. Thus, the links between two concepts

can be assessed by measuring the distance between them on such neural links. In terms of cognition, the IAT is based on the automatic processing of attitudes. It is a computerized categorization task that assesses the extent of automatic link between two types of items (target/attribute) to gauge an individual's implicit attitude. When target and attribute items are compatible, that is, their relationship aligning with the participant's implicit attitude, classification is more automatic and easily processed under fast conditions, resulting in shorter latency. Conversely, when target and attribute items are incompatible, that is, their relationship is inconsistent with the participant's implicit attitude, it leads to cognitive conflict and requires more complex conscious processing, resulting in longer latency. The distinction in latency between incompatible and compatible conditions is an indicator of implicit attitude. Thus, the IAT measures implicit attitudes by assessing the strength of automatic link between target and attribute items.

Mierke and Klauer (2003) recommended the task-switching account to explain the mechanism underlying the IAT effect. They suggested that in the compatible condition of the IAT, the target and attribute categories share common attributes and are mapped to the identical response key. Participants can derive responses from the common attributes of the target category, resulting in faster performance. In contrast, in the incompatible condition, participants cannot derive responses from the common attribute, and need to ignore the attribute-related information for the target category and focus on the exemplars of the attribute categories. This process requires executive control mechanisms, which involves identifying and switching to the appropriate task set. The key assumption of the task-switching account is that executive control mechanisms play a crucial role in the IAT effect.

As an indirect measure, the IAT utilizes latency as the standard to infer attitudes, and its fundamental principles must be convincingly explained. The aforementioned researchers attempt to elucidate this fundamental principle. Regardless of their interpretations, they all follow the same logic, namely that latency length reflects the complexity of internal brain processing. Short latency indicates that the processing is simple and effortless, and may even be subconscious, whereas long latency suggests that the processing is complex and challenging, possibly accompanied by conscious cognition. Latency length serves as an indicator of attitude tendencies.

2.2.4.2.1.3. Calculation of IAT effect

Table4 Conventional and improved IAT scoring algorithms compared

Step	Conventional algorithm	Improved algorithm
1	Use data from B4 & B7	Use data from B3, B4, B6, B7
2	Nonsystematic elimination of subjects for excessively slow responding and/or high error rates	Eliminate trials with latencies >10,000 ms; eliminate subjects for whom more than 10% of trials have latency less than 300 ms
3	Drop first two trials of each block	Use all trials
4	Recode latencies outside 300/3,000 boundaries to the nearer boundary value	No extreme-value treatment (beyond Step 2)
5		Compute mean of correct latencies for each block
6		Compute one pooled SD for all trials in B3 & B6; another for B4 & B7
7		Replace each error latency with block mean (Computed in Step 5) +600 ms
8	Log-transform the resulting values	No transformation
9	Average the resulting values for each of the two blocks	Average the resulting values for each of the four blocks
10	Compute the difference: B7 - B4	Compute two differences: B6 - B3 and B7 - B4
11		Divide each difference by its associated pooled-trials SD from Step 6
12		Average the two quotients from Step 11

Note: This table is adapted from Greenwald et al. (2003). The conventional algorithm has no procedures corresponding to Steps 5-7 or Steps 11-12 of the improved algorithm. SD =standard deviation.

One common way to assess the IAT effect is to examine the latency differences between specific blocks, such as B4 and B7 in the case of measuring gender evaluations. If the latency of B4 is lower than that of B7, it suggests that males are more strongly connected to pleasant words and females to unpleasant words, indicating a more positive implicit attitude towards males. Conversely, a higher latency for B4 than B7 suggests a more positive implicit attitude towards females. The scoring conventions most frequently used by researchers when reporting IAT results were originally described in the first publication of the IAT by Greenwald et al.

(1998). However, Greenwald et al. (2003) evaluated alternative scoring procedures using five indicators such as internal consistency to improve the reliability and effectiveness of IAT measurements, despite the widespread use of this scoring convention. Finally, the D algorithm emerged as the strongest candidate, outperforming the conventional scoring procedure. Generally, an IAT effect with $.15 \leq D < .35$ is considered low, $.35 \leq D < .65$ is moderate, and $D \geq .65$ is strong. Table 4 shows the comparison between the traditional algorithm and the improved algorithm (D algorithm).

2.2.4.2.1.4. Reliability and validity of IAT

IAT is frequently used as a measurement of implicit social cognition, and researchers have expressed concerns about its reliability and validity as a psychometric instrument. To be considered a good measure, it must meet the requirements of psychometric for both reliability and validity.

a) Reliability of IAT

In the study of latency-based measurement methods, such as the IAT, there are many factors that can cause error variance, such as external noise, participant sneezing, car horns, and even blinking, which may greatly weaken the reliability of the measurement (Lane et al., 2007). In contrast, self-report scales are less affected by such factors. Therefore, it is generally believed that the internal consistency of latency-based measurement methods is less than that of self-report measurement methods (Buchner & Wippich, 2000). However, the internal consistency of IAT is much higher than that of other latency-based measurement methods (Bosson et al., 2000). Hofmann et al. (2005) conducted a meta-analysis of 50 studies and found that the internal consistency of IAT was .79. Additionally, Greenwald and Lai (2020) showed that the internal consistency of IAT was .80. Overall, the IAT captures most of the systematic variance in whatever combination of latent variables bases on a single-occasion measure. Therefore, the internal consistency of IAT is reasonable and acceptable.

Compared to its internal consistency, the test-retest reliability of the IAT is generally considered to be less than ideal. B. A. Nosek et al. (2007) found that the test-retest reliability of the IAT was .56, which was not substantially affected by the retest interval. In their analysis of 58 studies, Greenwald and Lai (2020) determined that the average

test-retest reliability of the IAT was .50. They acknowledged that while this may appear low, it is still considered sufficient for studies examining the correlation between the IAT and other measures, as well as for studies exploring group differences or experimental treatment effects on mean IAT scores. Overall, while the test-retest reliability of the IAT is not as high as its internal consistency, it is still widely used and considered a helpful measurement of implicit social cognition. The difference in performance between internal consistency and test-retest reliability may be due to the occurrence of systematic variance in a single IAT is not co-existent across measure occasions.

b) Validity of IAT

Previous research has examined the correlation between IAT and other implicit measurements, as well as the connection between IAT and self-report measurements. The correlation between IAT and alternative implicit measurements has been found to be weak, while the correlation between IAT and self-report measures varies across researches (Bosson et al., 2000; Olson & Fazio, 2003). Early studies suggested that IAT and explicit measures had little correlation, emphasizing the uniqueness of IAT compared with explicit measurement, while later studies found a stronger correlation between the two. Hofmann et al. (2005) reported an average correlation of .24 in a meta-analysis, while Nosek et al. (2005) reported an average of .37 across 57 different content domains.

Regarding convergent and discriminant validity, it raises questions about whether IAT and self-report measurement assess distinct constructs. The convergent and discriminant validity of the IAT has been a topic of debate in the literature. Nosek and Smyth (2007) administered a Multitrait-multimethod (MTMM) survey of the IAT and self-report measurement across 7 attitude domains, and discovered solid evidence that supported the convergent and discriminant validity of the IAT. They reported that the IAT attitude measures were related to their corresponding self-report measurements. Furthermore, after controlling for common method variance in both measures, their MTMM investigation showed that the IAT and self-report measurements were constructs that are linked but separate, rather than constructs that are single, as evidenced by their structural equation modeling. Tosi et al. (2020) utilized the IAT to gauge attitudes regarding dangerous driving, and observed that the driver social desirability scale was positively correlated

with most self-report measurements, but not with the IAT. Based on these findings, the researchers suggested that the IAT could serve as an effective indirect measurement of dangerous driving, and could be used to supplement traditional self-report measures of driving attitudes. Nevertheless, Schimmack (2021) investigated the discriminant validity of the IAT across various multi-method studies and reported a lack of evidence supporting the discriminant validity of the IAT. These conflicting findings suggest that there is a need for further research on these issues.

Regarding the predictive validity of the IAT, Uhlmann et al. (2009) administrated a meta-analysis and found that the average r for prediction of behavioral, judgment, and physiological measures was .274. Although parallel self-report measurements also predicted effectively (average $r = .361$), the effect size varied greatly. When it comes to sensitive social issues such as Black-White interactions, the predictive validity of IAT is higher than that of self-report measurements. While explicit measurements are generally more valid than the IAT across all domains, using a multi-method measurement model that incorporates the IAT can help to minimize measurement error when assessing sensitive attitudes.

2.2.4.2.2. Stereotypic explanatory bias

Explanatory bias, first introduced by Hastie (1984), refers to the phenomenon whereby individuals engage in more attributional behaviors in response to situations that deviate from their expectations in order to justify the inconsistency. Since these expectations may be influenced by stereotypes, explanatory bias can also occur in response to inconsistencies in stereotypes. Stereotypic explanatory bias (SEB) can provide a suitable measure of implicit stereotypes because it reflects the impact of stereotypes on processing when unexpected situations arise (Sekaquaptewa et al., 2003).

The SEB procedure involves administering a questionnaire to participants containing sentences with blanks to fill in for various reasons. The first half of each sentence presents an event outcome, while the second half requires participants to provide an attribution for the described event. Some of the sentences relate to stereotyped themes, known as SEB items, while others are neutral or irrelevant. The subject of the SEB items must be a social group related to stereotypes, and the SEB items must also present behaviors consistent or

inconsistent with stereotypes. After completing the questionnaire, two or more researchers classify and code the participants' explanations for the second half of each SEB item and determine whether the content constitutes an explanation of the behavior described in the first half or merely repeats its meaning. The number of explanations provided by participants for the subject's behavior in situations consistent with stereotypes (recorded as XX) and inconsistent with stereotypes (recorded as XY) are then calculated, and the SEB score is obtained by subtracting XX from XY (Yu & Liang, 2005). Psychological studies on attribution have shown that when a person's behavior deviates from expectations, individuals tend to make environmental rather than personal attributions (Liu, 2010). Thus, the SEB can also analyze the nature of attributions (internal or external, personal or environmental) to provide additional information.

Zuo and Liu (2006) proposed that compared to the widely used IAT method, the SEB has the advantage of being closer to reality and more naturally stimulating individuals' implicit attitudes, thus compensating for the shortcomings of current IAT measurement methods. Therefore, the SEB has optimistic application prospects in the social cognitive research field related to stereotypes. As a result, an increasing number of researchers have adopted SEB to study implicit stereotypes. For instance, Ying and Xiangcai (2015) used SEB to investigate the occupational gender stereotypes of college students and found that college students generally held occupational gender stereotypes, and there was no sex or grade difference in the results. Additionally, Zuo and Liu (2006) utilized IAT and SEB to measure the implicit gender stereotypes of 120 college students. The results indicated that college students had strong implicit gender stereotypes, and their stereotypes about males aligned with traditional cognition. However, the stereotypes of females differed from traditional cognition. Furthermore, inconsistent results were found when comparing the implicit gender stereotypes of college students measured by IAT and SEB methods.

In addition to the latency-based paradigm and SEB, indirect measurement of gender stereotypes also includes the signal detection paradigm, evaluative priming task, and other methods, which will not be discussed here. These methods provide different approaches to measuring implicit attitudes and biases, allowing for a more in-depth understanding of the complex nature of gender stereotypes.

2.3. Gender stereotypes of college students

The present studies focus on the gender stereotypes of Chinese CSGC college students. Therefore, when reviewing the literature, special attention must be given to understanding what gender stereotypes are prevalent among college students and whether there are any unique characteristics in the gender stereotypes of CSGC college students. As previously mentioned, gender stereotypes can be divided into various categories, such as trait gender stereotypes, occupational gender stereotypes, subject gender stereotypes, math gender stereotypes, language gender stereotypes, and more. Previous research on the gender stereotypes of college students generally aligns with this categorization. Some studies focus on the trait gender stereotypes of college students, while others concentrate on the subject gender stereotypes of college students. Thus, this review will follow this content classification standard and examine the existing research on the gender stereotypes of college students, paying special attention to any unique features of CSGC college students' gender stereotypes. By doing so, this research aims to contribute to a thorough understanding of gender stereotypes prevalent among college students in China, particularly among the CSGC college students.

2.3.1. Trait gender stereotypes of college students

When examining college students' trait gender stereotypes, two critical questions arise. Firstly, what are the typical trait gender stereotypes that exist among college students? Secondly, with the changing times and the evolution of women's social status, will these trait gender stereotypes change correspondingly?

2.3.1.1. What are the typical trait gender stereotypes that exist among college students?

Previous studies have explored the typical trait gender stereotypes that exist among college students. Rosenkrantz et al. (1968) and Broverman et al. (1972) conducted studies of college students in many institutions of higher learning in New England and found that gender role stereotypes were prevalent among respondents based on their gender, socio-economic class, and religion, at least among those seeking higher secondary education. Women were viewed as relatively lacking in ability, independence, objectivity, and logic, while men were considered to lack interpersonal sensitivity, warmth, and expression ability. Bergen and Williams (1991) conducted a survey on the gender stereotypes of 100 college students using an adjective

checklist. Their findings showed that items associated with women were generally viewed more positively, while items associated with men were considered stronger and more active. Interestingly, this gender stereotype was found to be consistent between 1972 and 1988. Hosoda and Stone (2000) conducted a study on current gender stereotypes by asking 173 undergraduate students to rate 300 attributes. The results manifested that male and female students had a strong consensus on the gender ascription of many properties, and believed that there were still differences between male and female on several attributes. The study identified a set of "key" masculine properties such as handsome, aggressive, tough, and dominant, as well as "key" feminine traits such as affectionate, sensitive, and emotional. Interestingly, the current feminine stereotype consisted of a roughly equal number of favorable, unfavorable, and neutral attributes. Piatek-Jimenez et al. (2018) conducted a survey on college students from two American universities to explore gender stereotypes. The study found that women were often stereotyped as caregivers, with traits such as being "concerned about future family obligations" and "putting others' needs above one's own needs" being perceived as female-dominated characteristics. On the other hand, male-dominated traits were closely associated with success in the business world, with participants identifying traits such as "competitive", "inclined to take risks", and "a leader" as being male-dominated.

What about Chinese college students? Qian et al. (1999) surveyed 380 Chinese college students on their gender stereotypes and found that their views were more consistent with traditional gender roles, which portray men as stronger and more capable, and women as passive and obedient. In a study by Qin and Yu (2001) involving 1256 participants (958 of whom were college students), it was found that the most important personality characteristics attributed to men were creativity, humor, self-reliance, optimism, and competence, while the most undesirable traits were haggling, shortsightedness, bullying, indecision, and inferiority. Conversely, the most important characteristics attributed to women were self-reliance, kindness, gentleness, and elegance, with the most undesirable traits being open-mindedness, dependence, fussiness, inferiority, and extravagance. In another study by Xu (2003), male and female participants (mostly college students) perceived men as brave, strong, adventurous, and strong in leadership roles, while women were viewed as considerate, obedient, orderly, lovely, and emotional. Using the IAT and SEB, Zuo and Liu (2006) found that there was a strong

implicit gender stereotype among the 120 college students surveyed. Specifically, traditional gender roles were more strongly associated with male stereotypes, while female stereotypes were perceived differently. Overall, these studies suggest that traditional gender stereotypes still persist among Chinese college students, with men and women being perceived and evaluated based on different sets of traits and characteristics

Previous researches have revealed that both Chinese and foreign college students tend to hold trait gender stereotypes, indicating that this phenomenon is cross-cultural in nature. Specifically, these stereotypes connect traits such as rationality, ability, and courage with males, while linking tenderness, sensitivity, and emotion with females. This overall pattern of trait gender stereotypes highlights the persistence of gender roles and expectations, which continue to shape how male and female are perceived and evaluated in different societies and cultures.

2.3.1.2. Do college students' trait gender stereotypes change with the times?

It is undeniable that women's social status has undergone significant changes that correspond with the development of society. As such, the question arises as to whether college students' trait gender stereotypes have evolved along with women's changing roles. In answering this question, there are two theoretical assumptions. The first is social-role theory (Eagly, 2013), which suggests that gender stereotypes are partly obtained through observing individuals in their societal roles, and therefore predicts evolution in the stereotypes associated with male and female over time. The second view, represented by Helmreich (1982) and Spence (1984), argues that social development do not inevitably lead to evolution in gender stereotypes. Moreover, Helmreich (1982), proposes that masculinity and femininity, which are gender-linked personality traits or attributes, represent "relatively stable clusters of internalized traits that appear to be relatively independent of social changes in the status of the two sexes."

What is the actual research result? Bergen and Williams (1991) replicated a study conducted in 1972 on college students' trait gender stereotypes in 1988. The participants were requested to respond to a 300-item adjective checklist. The results indicated a high correlation ($r=.90$) between the 1972 and 1988 arrays of index scores across all 300 items. The study found no changes in the affective meaning associated with men and women stereotypes over the

sixteen-year period. Lueptow et al. (1995) surveyed 600 students across six waves between 1974 and 1991 and found that there was stability in trait gender stereotypes and even a small rise in sex typing. Haines et al. (2016) organized a study to examine whether gender stereotypes are still prevalent in today's society contrasted with the earlier research of Deaux and Lewis (1983) by using the same methodology to collect data. The results showed that people still hold strong gender stereotypes regarding the differences between male and female, similar to the findings of the earlier study. Therefore, the trait gender stereotypes of college students have stayed relatively unchanged over the past few decades. Nonetheless, it should be noted that some minor changes might have occurred. During the time period from 1972 to 1988, Bergen and Williams (1991) observed some minor changes in the trait gender stereotypes of college students. Specifically, they found that the male stereotypes decreased in the traits of adult and nurturing parent, while increasing in free child. On the other hand, the female stereotypes decreased in free child and exhibited a trend toward an increase in adult. The researchers concluded that there had been some substantial changes in the stereotypes during this period. Lueptow et al. (1995) reported an strengthen in sex-typing and gender differentiation, particularly in the recognition of women's increasing femininity by both male and female. Haines et al. (2016) discovered that while gender stereotypes remained stable across all categories from 1983 to 2014, there was a significant rise in gender stereotyping related to female gender roles. The participants perceived strong stereotyping in female gender roles.

Over the course of half a century, researchers have replicated previous studies on college students' trait gender stereotypes. The results consistently show a high degree of correlation, indicating that despite the changing times, college students' trait gender stereotypes have remained largely consistent with traditional views and have maintained a significant level of stability. While there may have been some minor changes, they have not fundamentally altered the core views that college students hold regarding male and female traits. It can be concluded that gender stereotypes remain prevalent in modern society, particularly with regards to female gender roles. These findings highlight the need for continued workings to challenge and change deeply entrenched stereotypes and promote greater gender equality.

2.3.2. Subject gender stereotypes of college students

Guimond and Roussel (2001) conducted three studies investigating gender stereotypes on abilities among high school and college students, as well as its impact on self-evaluation. The results of all three studies showed that students generally perceive women as better than men in language abilities, while men are considered better in science and mathematics. These studies also found that female college students who have faith in that males are better in science had markedly inferior abilities and self-esteem in science than those who do not hold this belief. Furthermore, they also reported lower average performance in science than those who do not assume that males are superior than females in science. Brian A Nosek et al. (2007) conducted a large-scale network study, which collected implicit attitudes and stereotypes data sets from 2000 to 2007, and found that 72% of the participants demonstrated more robust connections of science with men and humanities with women than the reverse academic-gender pairing on the gender-science/humanities IAT and also reported deepened ties science with male more than with female. Interestingly, the study found that implicit and explicit stereotypes were positively correlation, and this effect was detected for both male and female, both implicitly and explicitly. In a survey executed by Nosek et al. (2009), more than half a million IAT were finished by individuals from 34 different countries. The outcomes demonstrated that approximately 70% of the participants exhibited implicit stereotypes that tied science with males more than with females. Miller et al. (2015) carried out an investigation involving 350,000 participants from 66 countries and regions, with 50% of participants having a university diploma or higher, and 79% having some college or higher. The study aimed to investigate explicit and implicit subject gender stereotypes. The results, based on the average scores of each country, showed a strong association between science and men in both explicit and implicit measures. This suggests that subject gender stereotypes are prevalent among college students in all countries.

What is the situation of subject gender stereotypes among Chinese college students? Cai et al. (2001) investigated 47 Chinese college students by measuring subject gender stereotypes with IAT and designing an attitude scale to measure explicit attitudes. The outcomes demonstrated that there was no significant gender difference in implicit subject gender stereotypes, indicating that these stereotypes existed implicitly and universally among Chinese male and female college students, and had an impact on people's daily concepts and behaviors in an

automatic way. However, it is interesting to note that in the corresponding explicit attitude, there was no significant difference between students of different genders and subjects, indicating that modern college students tend to show an attitude of gender equality on the surface to conform to the trend of the times. He and Liu (2007) utilized a subject gender stereotypes questionnaire and the IAT to measure 180 college students. The results revealed an experimental dissociation between explicit and implicit subject gender stereotypes. In the explicit test, participants believed that there was no significant difference between male and female in their ability to learn arts and science majors. However, in the implicit measurement, participants believed that men were significantly better than women in learning science and engineering majors, while men and women had the same ability in learning arts and history majors. Li and Jia (2009) used the SEB to investigate the implicit subject gender stereotypes of college students. The findings showed that college students generally held implicit subject gender stereotypes that males are more suitable for science and engineering subjects, while females are more suitable for arts and history subjects. Moreover, these implicit subject gender stereotypes had no gender or major differences. Li (2016) conducted an IAT study on 81 college students in Sichuan Province, China, to examine their implicit subject stereotypes. The results indicated that there were implicit subject gender stereotypes in many regions of Sichuan Province, where participants believed that males should choose science and engineering subjects, while females should choose literature and history subjects. Furthermore, the IAT effect had significant sex differences, but major differences were not apparent.

Several studies conducted in China and other countries have indicated that subject gender stereotypes are common among college students. The view that "males are better at learning science, while females are better at learning arts" is widely accepted by college students.

2.3.3. Math gender stereotypes of college students

It is a well-established fact that mathematics falls under the umbrella of science and engineering, while language is classified under liberal arts. However, science and engineering encompass more than just mathematics; they also include science, technology, and engineering. Similarly, liberal arts encompass more than just language; they also include pedagogy, sociology, philosophy, and other subjects. As a result, math/language gender stereotypes can be considered a sub-concept of subject gender stereotypes. The reason why it is necessary to

discuss math/language gender stereotypes separately after subject gender stereotypes is that there is a plethora of research available in this area.

Smeding (2012) conducted a study in southern France to explore the implicit gender-stem stereotypes and its association with performance among male and female engineering and humanities students. The study found that the implicit math gender stereotypes of female engineering students in France were weaker compared to female liberal arts students, as well as male engineering and male liberal arts students. In a study conducted by Nosek et al. (2002) at Yale University, math and language gender stereotype tests were administered to undergraduate students using IAT. The study revealed that both men and women were able to classify math+male (and arts+female) more easily than the opposite pairings. Moreover, there was no significant sex difference observed in the magnitude of this effect. These findings suggest that both men and women exhibit similar implicit math-gender stereotypes, even though they may differ in their preferences for math. Thus, men and women display comparable implicit knowledge when it comes to the relationship between gender and math. Morrissey et al. (2019) conducted a study on a sample of 80 college students to investigate their explicit and implicit mathematical gender stereotypes. The findings revealed that the participants self-reported typical mathematical gender stereotypes and showed a correlation between the explicit and implicit measurement of these stereotypes. In other words, the study suggests that college students are aware of and adhere to common gender stereotypes in relation to mathematics, both in their conscious beliefs and their unconscious biases. Ma and Liang (2006) employed the SEB to examine the prevalence of mathematical gender stereotypes among 60 Chinese undergraduate students. Their study revealed that implicit gender stereotypes, such as the notion that "men are more skilled in mathematics than women," were widespread among college students, and there were no significant differences in gender or major. In a subsequent study, Ma and Liang (2008) conducted another study with 60 college students, using the IAT to examine implicit mathematical gender stereotypes. The results indicated that the participants held an implicit stereotype that "men are more proficient in math than women" based on the IAT. Moreover, while no significant sex differences were found, the study did reveal differences among participants based on their profession or major in their implicit gender stereotypes.

The association between boys and mathematics has a lengthy historical background. While recent research indicates that this association has undergone a shift, it remains a pertinent issue that warrants further investigation.

2.3.4. Language gender stereotypes of college students

Guimond and Roussel (2001) conducted three studies that demonstrated how French college students tend to associate women with superior language skills, while girls in high school who pursue language-oriented careers have lower self-evaluations of their scientific abilities. Conversely, students in science fields often underestimate their language skills. The results of an investigation of 1672 college students revealed that the perception of language as a female-oriented subject was widespread among the participants. However, subsequent study has suggested that stereotype threat effects on men in language are not well-supported (Chaffee, Lou, & Noels, 2020; Chaffee, Lou, Noels, et al., 2020). According to Plante et al. (2009), while the traditional stereotype linking boys to mathematics may have undergone a shift, language continues to be viewed as a field dominated by women. Martinot et al. (2011) discovered that children held "conventional" gender stereotypes regarding reading abilities, which were favorable towards women. Furthermore, gender stereotypes related to language were also present among children, regardless of the age of the person being stereotyped (child or adult).

While research on gender stereotypes in math has been extensive, relatively little focus has been given to gender stereotypes in language. This is precisely what the current study seeks to address.

2.4. Counter gender Stereotypes

Counter gender stereotypes refer to any phenomenon that goes against the commonly accepted gender stereotypes. Current research in this area primarily centers on the following areas.

Firstly, researchers have focused on the impact of stimuli or situations containing information that counteracts gender stereotypes, such as textbooks, advertisements, or experimental materials and situations designed by researchers. In their study, Good et al. (2010) explored the impact of stereotyped and counter gender stereotyped textbook pictures on high school students' understanding of science lessons. Their findings revealed that female students showed greater understanding of the science lessons when exposed to counter stereotype

pictures, as opposed to stereotype pictures (depicting male scientists), which supports the assumption. It has also been found that context of counter gender stereotypes has the possibility to enhance women's performance in mathematics by demonstrating that women are equally competent in this field, as well as by activating the positive association between STEM and women (Marx & Roman, 2002). Finnegan et al. (2015) examined the effectiveness of counter-stereotypical images in reducing the impact of spontaneous gender stereotypes associated with certain social role nouns and professional terms. The study suggests that exposure to counter-stereotypical images can be an effective short-term strategy for combating gender stereotype biases. However, the outcomes of studies are not always consistent. Morin-Messabel et al. (2017) investigated the impacts of stimulating counter-stereotypes, stereotypes, and gender-neutral conditions on the mathematical test scores of fourth-grade male and female students in a real-life classroom setting. The results indicated that under the stereotype condition, female students performed significantly better than male students, left considerably less questions blank, and gave themselves substantially greater self-evaluation scores than male students. However, under the counter-stereotype condition, male students performed better and gave themselves substantially greater self-evaluation scores than female students. The counter-stereotype pictures improved male students' test performance but noticeably weakened female students' scores.

Secondly, researchers have focused on people's evaluation of stimuli containing counter gender stereotypes information. For instance, Wen et al. (2020) conducted a study where participants were presented with facial images of male and female that varied from high gender stereotypes to high gender counter stereotypes (GCS). Participants were then asked to assess these faces, and according to their evaluations, the researchers proposed a threshold model for the maintenance of gender stereotypes. According to this model, targets with balanced gender stereotypical and counter gender stereotypical traits tend to be evaluated more positively than targets that strictly conform to gender stereotypes or counter gender stereotypical traits.

To summarize the literature review, there is a general consensus among researchers regarding the definition of stereotypes and gender stereotypes. They consider stereotypes to be simplified and fixed views of the traits of members of a certain group, while gender

stereotypes are generalizations about the characteristics of male and female. Both stereotypes and gender stereotypes can be divided based on their content or measurement method. Research on gender stereotypes among college students is also relatively abundant. Overall, many studies have demonstrated that implicit trait gender stereotypes, subject gender stereotypes, and math/language gender stereotypes are consistent with traditional gender views, while their explicit counterparts may be inconsistent.

3. Research Ideas

3.1. Basis for establishment of the present studies

Generally, a study can be motivated by the limitations of previous research or by questions that previous research cannot answer. In this section, I will discuss the limitations of previous studies identified in the literature review and the improvements that the present research aims to make. This will serve as the basis for establishing the present studies.

3.1.1. Limitations of previous studies

3.1.1.1. Limitations of research objects

From the literature review, it can be observed that most previous studies have focused on gender stereotypes of general college students, with little attention paid to CSGS college students. While it is true that most college students conform to gender stereotypes in their choice of major, the uniqueness of CSGS college students who challenge subject gender stereotypes cannot be ignored. However, there has been little research carried out on this particular group, and it remains unclear what motivates their choice to challenge gender stereotypes in their major selection. Furthermore, while there have been studies focusing on the impact of stimuli or context bearing counter gender stereotypes information on people, there has been little attention paid to counter gender stereotypes people themselves. As a result, the gender stereotypes of CSGS college students are still a mystery that requires further investigation.

3.1.1.2. Limitations of research content

Another limitation of previous research on gender stereotypes of college students is the lack of systematic and comprehensive content. Previous studies have focused on particular facets of gender stereotypes, such as trait gender stereotypes, subject gender stereotypes, math/language gender stereotypes, and sports gender stereotypes. However, few studies have systematically and comprehensively investigated the gender stereotypes held by college students. A comprehensive study should explore all aspects of college students' gender stereotypes to obtain a better understanding of their beliefs. This is particularly important for understanding the gender stereotypes of CSGS college students, as this group has not been thoroughly studied in previous research.

3.1.1.3. Limitations of research methods

Gender stereotypes of college students are an interdisciplinary research topic that can be classified under sociology, psychology, and pedagogy. Currently, psychology places more emphasis on the gender stereotypes of college students. As such, it exhibits an obvious feature of psychological research methods, focusing on the measurement of gender stereotypes. In psychology, gender stereotypes measurement involves direct and indirect methods. Before the invention of indirect measurement, direct measurement was the primary approach, which measured the explicit gender stereotypes of participants. After the introduction of indirect measurement, it became more popular, even surpassing direct measurement. Current studies consider both methods to ensure the accuracy and comprehensiveness of gender stereotypes measurement. However, some studies do not consider both methods, relying on either direct or indirect measurement alone, which may not guarantee the accuracy and comprehensiveness of gender stereotypes measurement.

3.1.1.4. Limitations of theoretical construction

A critical theoretical question in the study of gender stereotypes is whether gender stereotypes exist universally in the minds of all individuals in society, or whether different individuals hold different attitudes towards men and women for various reasons, even if these attitudes are completely opposite to gender stereotypes. If it is the former, it implies that gender stereotypes, as pre-existing cultural elements, shape the attitudes and ideas of individuals in society. This shaping force is powerful, and individuals cannot change it through any means. Following this logic, it is inevitable that every individual in society must share gender stereotypes. If there are differences between individuals, they are only differences in degree, not in essence. If it is the latter, it implies that even though gender stereotypes have a strong shaping power, individuals can still form a completely different view and attitude towards men and women for some reason and can be free from the constraints of gender stereotypes. This is undoubtedly a ray of hope for the true achievement of the free development of men and women.

When reviewing the literature, it can be found that previous studies have focused more on sex differences. Many studies have found that gender stereotypes exist indiscriminately in men and women. Researchers have also paid more attention to major differences. Many studies have found that there are differences in gender stereotypes among college students of different majors, but this is only a difference in degree. However, it is unclear whether any special

groups in current society hold attitudes and ideas completely different from gender stereotypes. How about CSGS college students? Have they overcome gender stereotypes, or are they no different from SGS college students? Previous research cannot answer these questions.

3.1.2. Improvement in present studies

After analyzing the limitations of previous research on gender stereotypes of college students, the present studies aim to improve upon these limitations.

3.1.2.1. Improvement in research object

In general, previous studies on gender stereotypes focused on general college students and did not specifically address the CSGS college students. While some CSGS college students may have participated in previous studies, this group is a small portion of the overall sample size. Therefore, the gender stereotypes held by CSGS college students remain largely unknown. The present studies aim to address this gap by focusing specifically on the gender stereotypes held by CSGS college students. Through preliminary interviews, it was found that while gender stereotypes are prevalent among CSGS college students' teachers, parents, and classmates, the CSGS college students themselves do not necessarily agree with these stereotypes and may consider themselves as exceptions. However, it is still unclear what their specific gender stereotypes are and whether they are truly exceptions. These are the questions that the present studies aim to answer.

3.1.2.2. Improvement in research content

As previously mentioned, earlier studies on gender stereotypes of college students often focused on one aspect of gender stereotypes, such as trait gender stereotypes or sports gender stereotypes. Few studies have conducted a comprehensive and systematic study of gender stereotypes, making it difficult to provide an all-encompassing and accurate description of college students' gender stereotypes, giving only a partial glimpse into the full picture, and thus hindering an overall understanding. Since the present studies are centered on the CSGS college students, it is essential to conduct a comprehensive and all-encompassing research on them from all aspects, with the aim of presenting a more accurate and comprehensive portrayal of the gender stereotypes held by CSGS college students.

3.1.2.3. Improvement in research methods

To address the limitations of previous studies, the present research will utilize a variety of

research methods to measure gender stereotypes among CSGS college students. Both direct and indirect measurement methods will be employed in order to avoid any bias that may arise from a single measurement method. This will allow for a more accurate portrayal of the gender stereotypes held by CSGS college students. Additionally, the present researches will investigate the relationship between explicit and implicit gender stereotypes, which will offer additional insight into the nature of gender stereotypes among this population.

3.1.2.4. Improvement in theoretical construction

In contemporary society, have any special groups formed attitudes and views completely different from the gender stereotypes? However, previous research has failed to address this question. Examining the gender stereotypes of the CSGS college students can provide some answers. The present studies focus on exploring the gender stereotypes of CSGS college students, as well as the correlation between these stereotypes and their performance. Moreover, the current studies may serve as a foundation for future research on similar groups, such as self-proclaimed feminists, who may also challenge traditional gender norms. While such groups represent potential avenues for breaking down gender stereotypes, it remains to be seen whether they have successfully achieved this goal, and this question requires further investigation.

3.2. Research design

3.2.1. Research purpose

The purpose of the present studies is to carry out a comprehensive and systematic investigation into the gender stereotypes held by CSGS college students. It will also explore the relationship between these gender stereotypes and attitudes towards math and language, as well as math and language performance.

3.2.2. Research participants

The present studies aim to investigate gender stereotypes among CSGS college students. Freshmen from Sichuan University of Science and Engineering in China were selected as participants, with 127 freshmen in the mathematics major (47 males and 80 females) and 241 freshmen majoring in Chinese language and literature (46 males and 195 females). Among them, 80 female freshmen in mathematics and 46 male freshmen in Chinese language and literature, totaling 126, are considered CSGS college students. Additionally, 47 male freshmen

in mathematics and 195 female freshmen in Chinese language and literature, totaling 242, were selected as SGS college students. The number and gender of participants are presented in Table 5. It is worth noting that mathematics is a typical science and engineering major, while Chinese language and literature is a typical liberal arts major. Participants were selected based on these considerations, and both CSGS and SGS college students were selected for comparison.

Table 5 Gender, major and number of participants

	The CSGS college students		The SGS college students	
	Male	Female	Male	Female
Math		80	47	
Chinese language and literature	46			195

3.2.3. Research questions

- a) What are the explicit gender stereotypes and sex role egalitarianism attitudes of the CSGS college students compared with the SGS college students?
- b) What are the implicit gender stereotypes of CSGS college students compared to SGS college students?
- c) What is the relationship between explicit gender stereotypes and implicit gender stereotypes of the CSGS college students?
- d) Do the gender stereotypes of CSGS college students affect their math and language attitudes? Which is a better predictor of math and language attitudes: explicit gender stereotypes or implicit gender stereotypes?
- e) Do the gender stereotypes of CSGS college students affect their math and language performance? Which is a better predictor of math and language performance: explicit gender stereotypes or implicit gender stereotypes?
- f) What is the relationship among gender stereotypes, math/language performance and math/language attitudes of the CSGS college students? Do math/language attitudes play a mediating role between gender stereotypes and math/language performance?

3.2.4. Research technology route

The technology route of the present studies is shown in Figure 1. These researches are divided into two parts from the perspective of research methods. One part is qualitative by means of interviews, and the other part is quantitative by means of scales and laboratory tests. Specifically, the function of the initial interview is to find that the CSGS college students do not agree with subject gender stereotypes and regard they are the exception. On this basis, the main issues to be explored in the present studies are refined: what are the gender stereotypes of the CSGS college students?

After identifying the main issues in the initial interviews, I conducted a thorough review of the literature and identified the limitations of previous research on these issues. Then I carried out a quantitative study to explore the gender stereotypes of CSGS college students, their math/language attitudes and math/language performance, as well as the relationship between these three variables. To measure the explicit and implicit gender stereotypes and math/language attitudes, I used both direct and indirect measurement methods, including scales and implicit association tests. This allowed for a comprehensive understanding of the gender stereotypes and attitudes of CSGS college students. Additionally, I examined the correlations among these variables and tested whether math/language attitudes play a mediating role between gender stereotypes and math/language performance.

During the implementation process, participants were asked to complete online questionnaires to provide their demographic information and data for various scales. One week later, they were invited to the psychology laboratory to conduct the IAT to collect implicit test data.

3.2.5. Research hypothesis

Firstly, as previous studies have paid little attention to the gender stereotypes of CSGS college students, there are limited research results available for reference. However, as CSGS college students choose a major that contradicts the prevailing subject gender stereotypes in society, they may hold gender stereotypes that differ significantly from those of others, which could challenge subject gender stereotypes. Secondly, although many studies on the gender stereotypes of college students have found no gender or major differences, there are individual studies that suggest that female engineering students exhibit inferior implicit math gender stereotypes than female liberal arts students and male engineering and male liberal arts

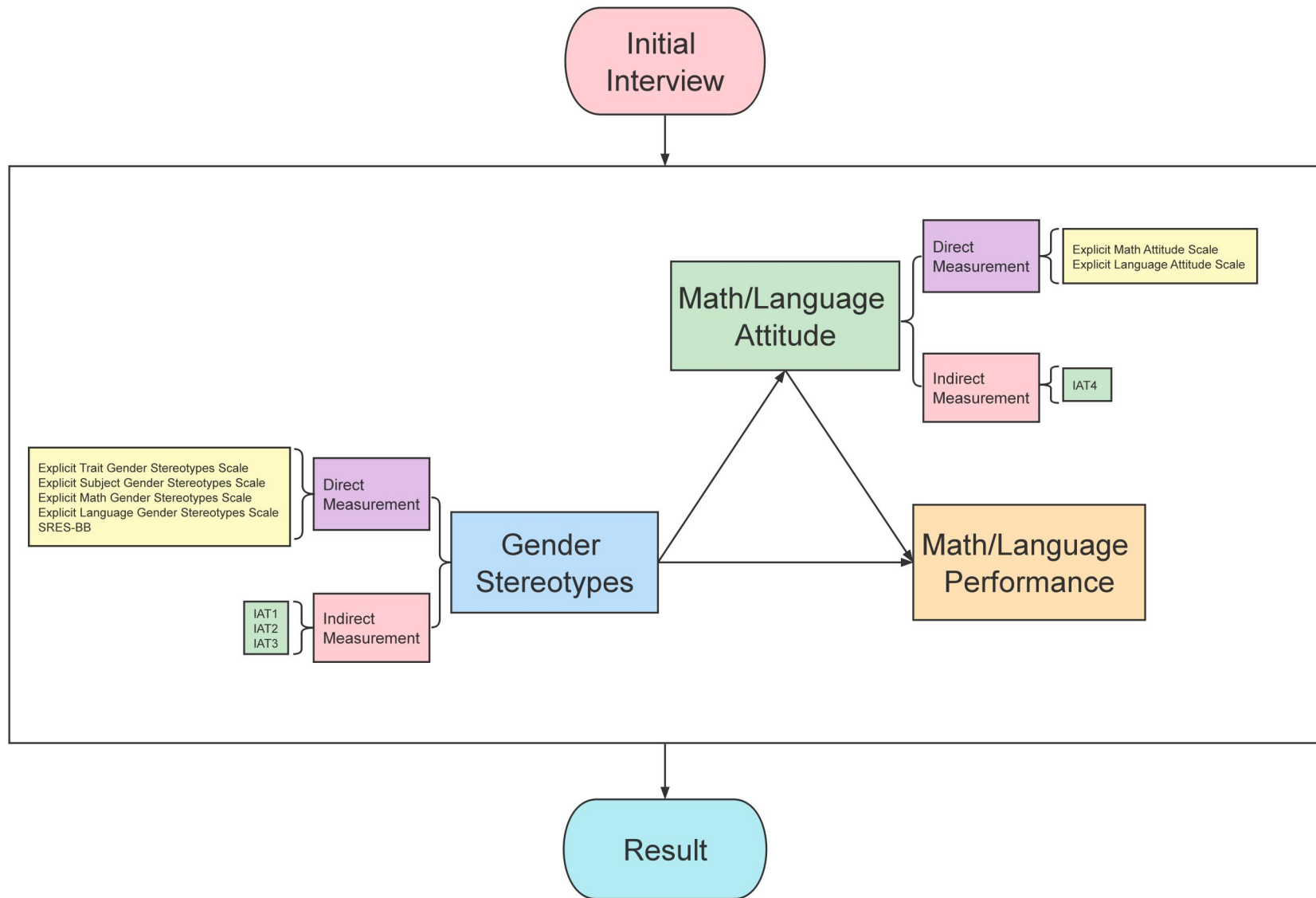

Figure1 Research technology route

students (Smeding, 2012). Finally, during the preliminary interview, both math major female and language major male expressed their disagreement with the gender stereotypes that "males are better at learning science, while females are better at learning arts." Therefore, the present studies assume that the gender stereotypes of CSGS college students differ from those of SGS college students. The hypotheses are as follows:

- H1: The top 5 words used by the CSGS college students to describe male and female traits are fundamentally different from those used by SGS college students;
- H2: Compared with the SGS college students, the CSGS college students have a stronger sex role egalitarianism attitude;
- H3: Compared with the SGS college students, the explicit subject gender stereotypes of the CSGS college students are weaker;
- H4: Compared with the SGS college students, the explicit math gender stereotypes of the CSGS college students are weaker;
- H5: Compared with the SGS college students, the explicit language gender stereotypes of the CSGS college students are weaker;
- H6: Compared with the SGS college students, the implicit trait gender stereotypes of the CSGS college students are weaker;
- H7: Compared with the SGS college students, the implicit subject gender stereotypes of the CSGS college students are weaker;
- H8: Compared with the SGS college students, the implicit math/language gender stereotypes of the CSGS college students are weaker;
- H9: There is a weak correlation between the explicit subject gender stereotypes and the implicit subject gender stereotypes of the CSGS college students, and even experimental dissociation may occur;
- H10: There is a weak correlation between the explicit math/language gender stereotypes and the implicit math/language gender stereotypes of the CSGS college students, and even experimental dissociation may occur;
- H11: There are differences in explicit math attitude between the CSGS and the SGS college students;
- H12: There are differences in explicit language attitude between the CSGS and the SGS

college students;

H13: There are differences in implicit math/language attitudes between the CSGS and the SGS college students;

H14: The explicit gender stereotypes cannot predict explicit and implicit math/language attitudes, while the implicit gender stereotypes can;

H15: The explicit gender stereotypes cannot predict math performance, while the implicit gender stereotypes can;

H16: The explicit gender stereotypes cannot predict English performance, while the implicit gender stereotypes can;

H17: Implicit and explicit math attitudes play a mediating role between gender stereotypes and math performance;

H18: Implicit and explicit math attitudes play a mediating role between gender stereotypes and English performance.

3.2.6. Research instruments

3.2.6.1. Scales

In the present studies, online questionnaires were used to investigate the explicit gender stereotypes and attitudes of the participants. The participants filled out the questionnaires on their mobile phones or computers. The questionnaire instruction read as follows: "Hello, classmate. We are conducting research on gender-related topics, and we need your answers to the following questions. Please read the questions carefully and answer them without omitting any. The survey is anonymous, and your privacy will not be disclosed. The collected data will only be used for research purposes."

The specific scales used in the questionnaire are listed below:

3.2.6.1.1. Explicit trait gender stereotypes scale

The present studies employed a free-response method to measure the participants' trait gender stereotypes. Specifically, participants were instructed to write down five words that best represent male characteristics and five words that best represent female characteristics. This method has the advantage of allowing participants to answer freely according to the questions, without being limited by the options provided by the researchers.

3.2.6.1.2. Sex role egalitarianism scale-BB(SRES-BB)

The SRES-BB was utilized to assess the sex role equality attitude of the participants. SRES-BB is a part of the SRES series, which includes SRES-B, SRES-K, SRES-BB, and SRES-KK. SRES-B and SRES-K were originally developed by Beere et al. (1984) and contain 95 items each. SRES-BB and SRES-KK are abbreviated versions of SRES-B and SRES-K, respectively, and were revised by King and King (1990). The aim of SRES is to capture the "bidirectional" shift from traditional gender roles to non-traditional ones, including not only beliefs or judgments about female role behavior but also those about male role behavior. A true egalitarian would not disapprove of either women's traditional male roles as business executives or men's traditional female roles as childcare providers (King & King, 1997). SRES-BB consists of 25 items across 5 domains of adult living: marital roles, parental roles, employment roles, social-interpersonal-heterosexual roles, and educational roles. Each dimension of SRES-BB comprises only 5 items, making it more concise. According to King and King (1990), SRES-BB has high internal consistency ($\alpha = .94$) and test-retest reliability ($r = .88$), and has been shown to have strong validity in many studies (King & King, 1990; King & King, 1997; McGhee et al., 2001). The Likert 5-point scale was used, where 1 indicates "very disagree" and 5 indicates "very agree." The total score ranges from 25 to 125, with higher scores indicating greater recognition of traditional sex roles for men and women.

3.2.6.1.3. Explicit subject gender stereotypes scale (ESGS)

The current studies utilized a self-made scale consisting of 20 items to assess explicit subject gender stereotypes. For example, participants were asked to rate the extent to which they believed mathematics, chemistry, physics, biology, history, education, and English were suitable for males or females, using sentence patterns such as "Mathematics is suitable for male" and "Mathematics is suitable for female". The items included in the scale for science and engineering, as well as liberal arts, were consistent with those used in the IAT for implicit subject gender stereotypes.

The scale was divided into 4 sub-scales, each containing 5 items. Sub-scale 1 assessed the extent to which participants believed science and engineering were suitable for men, named explicit science male gender stereotypes (ESMGS). Sub-scale 2 assessed the extent to which participants believed liberal arts were suitable for men, named explicit liberal arts male gender stereotypes (ELMGS). Sub-scale 3 assessed the extent to which participants believed science

and engineering were suitable for women, named explicit science female gender stereotypes (ESFGS). Sub-scale 4 assessed the extent to which participants believed liberal arts were suitable for women, named explicit liberal arts female gender stereotypes (ELFGS).

The scale used a 5-point Likert scoring method, with a range from 1-5, where 1 indicated "very disagree" and 5 indicated "very agree". The score range for each sub-scale was 5-25. The total score for sub-scale 1 and sub-scale 4 represented the subject gender stereotype (SGS) index, while the total score for sub-scale 2 and sub-scale 3 represented the counter subject gender stereotype (CSGS) index. In the current studies, the test-retest reliability of the scale was .812.

3.2.6.1.4. Explicit math gender stereotypes scale (EMGS)

The explicit math gender stereotype scale used in the current studies was adapted from the Fennema-Sherman mathematics attitudes scales developed by Fennema and Sherman (1976) and was revised by Chinese scholar Song (2014). This scale measures whether participants believe that mathematics is a subject that belongs to males, and it does so by assessing three aspects: male and female mathematical abilities, male and female achievements in math, and the appropriateness of males and females engaging in mathematics. The revised scale has a total of 11 items, and it uses a Likert 5-point scoring method. Song (2014) reported that the internal consistency reliability coefficient of the scale is .879, and the split-half reliability is .882, which meets the psychometric reliability requirements. Exploratory factor analysis revealed that a single factor was obtained, with a factor loading of at least .548 for each item, and the total explanatory capacity of the factor was 46.19%. Confirmatory factor analysis showed that the model fit was good, indicating that the scale has good structural validity (Song, 2014). The score range of the scale is 11-55, with higher scores indicating a stronger inclination towards math gender stereotypes.

3.2.6.1.5. Explicit language gender stereotypes scale (ELGS)

This is a self-developed scale, adapted from the math gender stereotypes scale created by Chinese scholar Song (2014). The 11 items were modified by replacing all instances of the word "math" with the word "language", while the remaining content was kept the same. The score range of the scale is 11-55, with higher scores indicating a stronger inclination towards language gender stereotypes. The test-retest reliability of the scale is .801.

3.2.6.1.6. Explicit math attitude scale (EMA)

This is a self-made explicit math attitude scale in the style of a semantic differential scale. The semantic differential scale is a measurement scale developed by (Osgood et al., 1957), typically consisting of a series of bipolar adjective pairs, and divided into 7 equivalent rating grades (sometimes 5 or 9). It is widely used in the study of people's attitudes towards their environment or objects. The explicit math attitude scale uses math as the evaluation object and employs a 5-point scale with paired adjectives at both ends of the scale, such as happy and sad, approaching and avoiding, suitable for men and suitable for women. This is a relatively quick and convenient way to measure attitudes towards math. The adjectives used in the pairs are consistent with those used in IAT. The test-retest reliability of this scale is .867.

3.2.6.1.7. Explicit language attitude scale (ELA)

This is a self-developed semantic differentiation scale. The explicit language attitude scale evaluates language attitudes using a 5-point scale, consisting of paired adjectives at both ends of the scale, such as happy and sad, approaching and avoiding, and suitable for men and suitable for women. The adjectives used in the paired adjectives are consistent with those used in IAT. Similar to the explicit math attitude scale, the explicit language attitude scale's test-retest reliability is .884.

3.2.6.2. Implicit association test

The implicit association test (IAT) was utilized to measure implicit gender stereotypes and attitudes. The present studies employed four IAT: IAT of implicit trait gender stereotypes, IAT of implicit subject gender stereotypes, IAT of implicit math/language gender stereotypes, and IAT of implicit math/language attitudes, which are referred to as IAT1, IAT2, IAT3, and IAT4, respectively. All four IAT were programmed using E-Prime 2.0 software, and participants were recruited to complete the tests in the university psychology lab. The researchers meticulously designed the entire IAT to align with the research objectives, including all details. While the target category, attribute category, and items varied, the four IAT were consistent in all other design aspects. As an illustration of the design of all four IAT, IAT1 will be used as an example.

3.2.6.2.1. Target category, attribute category and item design of IAT

In the IAT, there are two categories: target and attribute. The target categories are typically the

objects that need to be tested, while the attribute categories are the features related to the objects. Target and attribute categories must be paired separately. For example, in IAT1, the target categories are male and female, with masculine and feminine as attribute categories. Thus, there are a total of four categories. Each category contains several items, usually 4-6 items, which can be either pictures or words. The items of each category are carefully selected by researchers. The length and familiarity of the items are not important, but their ease of categorization into one of the four categories is crucial (Greenwald et al., 2022).

IAT1 is designed to measure the implicit trait gender stereotypes of participants, using male and female as target categories, and masculine and feminine as attribute categories. The items for male and female categories are selected from those used by Nosek et al. (2002), and include common words such as men, sons, fathers, women, daughters and others that indicate men and women. These items are easily recognizable and can be classified by participants. The items for masculine and feminine categories are selected from those used by Zuo (2015), and include characteristic words that describe men and women and can be easily identified and classified. Table 6 shows two target categories, two attribute categories and all the items used in IAT1.

Table 6 Target categories, attribute categories and items of IAT1

Category	Target		Attribute	
	Male	Female	Masculine	Feminine
Items	man	women	independent	dependent
	son	daughter	competitive	weak
	father	mothers	forthright	gentle
	husband	wife	brave	kind
	boy	girl	adventurous	obedient

In addition, it is important that the target category items and attribute category items are presented in a way that distinguishes them from each other on the computer screen. In IAT1, all target category items are displayed in green font, while all attribute category items are displayed in red font to indicate their difference.

Finally, the order of item presentation needs to be carefully designed. In B1, B2, and B5, all

items are presented randomly. In B3, B4, B6, and B7, the target and attribute items are presented in strict alternation, but which target item or attribute item is presented is randomized (Greenwald et al., 2022).

3.2.6.2.2. Tasks of 7 blocks in IAT

All IAT in the present studies were designed in accordance with the standard 7-step IAT. Table7 displays the tasks of each block in IAT1. It is worth noting that B1, B2, B3, B5, and B6 are all practice stages, while the real test stages are B4 and B7. Nonetheless, it is recommended to include the data of all four test stages (B3, B4, B6, and B7) in the statistical analysis (Greenwald et al., 2022; Greenwald et al., 2003).

Table7 Task of 7 Blocks in the IAT1

Block	No.of trials	Function	Task	Items assigned to left-key response	Items assigned to right-key response
1	20	Practice	Initial target categories classification	Items of male	Items of female
2	20	Practice	Initial attribute categories classification	Items of masculine	Items of feminine
3	20	Practice	Initial combined task(compatible)	Items of male Items of masculine	Items of female Items of feminine
4	40	Test	Initial combined task(compatible)	Items of male Items of masculine	Items of female Items of feminine
5	30	Practice	Reversed attribute categories classification	Items of feminine	Items of masculine
6	20	Practice	Reversed combined task(incompatible)	Items of male Items of feminine	Items of female Items of masculine
7	40	Test	Reversed combined task(incompatible)	Items of male Items of feminine	Items of female Items of masculine

3.2.6.2.3. Balance of 7 block sequences in IAT

In within-subject designs of psychological experiments, one of the most important aspects to consider is the order effect. Although previous studies have not found a statistically significant order effect in IAT, it is still recommended to balance the order in IAT designs(Greenwald et

al., 2022). For IAT1, there are two possible sequences: one is to conduct the compatible combined task (B3 and B4) first, followed by the incompatible combined task (B6 and B7); the other is to conduct the incompatible combined task first (B6 and B7), followed by the compatible combined task (B3 and B4). These sequences are labeled as Sequence1 and Sequence2 in Table8. During the test, both sequences should be designed for each IAT, and half of the participants should perform in Sequence1 and the other half in Sequence2 to achieve order balance.

Table8 Balance of 7 block sequences of IAT1

Sequence1	Sequence 2
B1-B2-B3-B4-B5-B6-B7	B1-B5-B6-B7-B2-B3-B4

3.2.6.2.4. Trial times design of each block of IAT

The number of trials for each block is determined by the number of items presented in the block. According to Greenwald et al. (2022), for each category with n items, B1 and B2 should have integer multiples of 2n trials, and B3, B4, B6, and B7 should have at least integer multiples of 4n trials. B5 requires more trials because it reverses the key arrangement. Based on the items presented in Table6, IAT1 has 5 items in each category. Therefore, the number of trials for IAT1 should be 20/20/20/40/30/20/40. See Table7.

3.2.6.2.5. Sequential balance of four IAT

Table9 Sequential balance of four IAT

No.	Sequence
1	IAT1 → IAT2 → IAT4 → IAT3
2	IAT2 → IAT3 → IAT1 → IAT4
3	IAT3 → IAT4 → IAT2 → IAT1
4	IAT4 → IAT1 → IAT3 → IAT2

To prevent order effects when participants complete all four IAT in the same order (IAT1 → IAT2 → IAT3 → IAT4), the researchers used a Latin square design to balance the order of the four IAT across participants. This resulted in four sequences, as shown in Table9, with participants randomly assigned to one of the sequences to control for order effects.

3.2.6.2.6. Process of IAT

The process of IAT can be divided into two levels. One level is the entire procedure of an IAT, from the welcome page to the end page. It includes not only a general instruction but also corresponding instructions for each block. These instructions serve as guidelines for participants to respond and determine all behaviors throughout the whole process. Figure2 illustrates the entire procedure of IAT1, and Appendix X shows the actual instructions displayed on the computer screen corresponding Figure2. Moreover, the process of the other three IAT is the same as that of IAT1.

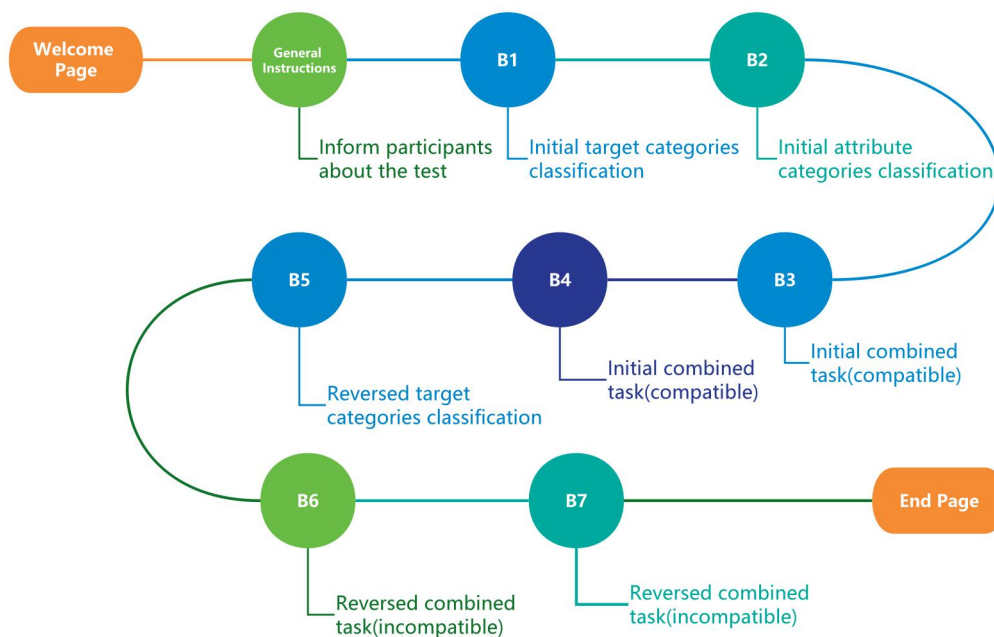

Figure2 The whole procedure of IAT1

Note: This is only the sequence1 of IAT1. The process of sequence2 is inconsistent with that of sequence1, as shown in Table8.

The other level is the core experimental procedure in an IAT, which refers to the smallest, repeatable experimental program that can be completed by a stimulus unit, namely a trial.

Figure3 shows the core experimental procedure of B1 in IAT1, and Appendix XI shows the actual pages displayed on the computer screen corresponding to Figure3. The task of B1 is to classify target categories. In this process, the instructions of B1 are presented first, and the duration is infinite. Its purpose is to give participants enough time to read the instructions, understand the requirements of the whole experiment, and decide when to start the formal experiment. Next is a fixation point "+", which takes 500 milliseconds to prompt participants to place their visual focus in the center of the screen. After the fixation point, the stimulus page appears, which is also the probe page. The word, e.g., "Man", appears in the center of the screen, and the duration time is infinite. Participants should quickly judge whether the word belongs to the male on the left or the female on the right. At the same time, E-prime program records the time interval from the presentation of the stimulus to the key pressing of the participants. This time interval is called the latency or the response time (RT), and it also records the accuracy (ACC) and other data. Then, after responding, the feedback page appears, where "√" or "×" will appear in the middle of the screen so that participants can immediately know whether the response they just made is correct or not. Finally, there is a buffer interval, which is used to delay the appearance of the next stimulus, and its duration is 250 milliseconds. The processes of the other blocks have changed compared to B1, especially B3, B4, B6, and B7, but they are basically the same.

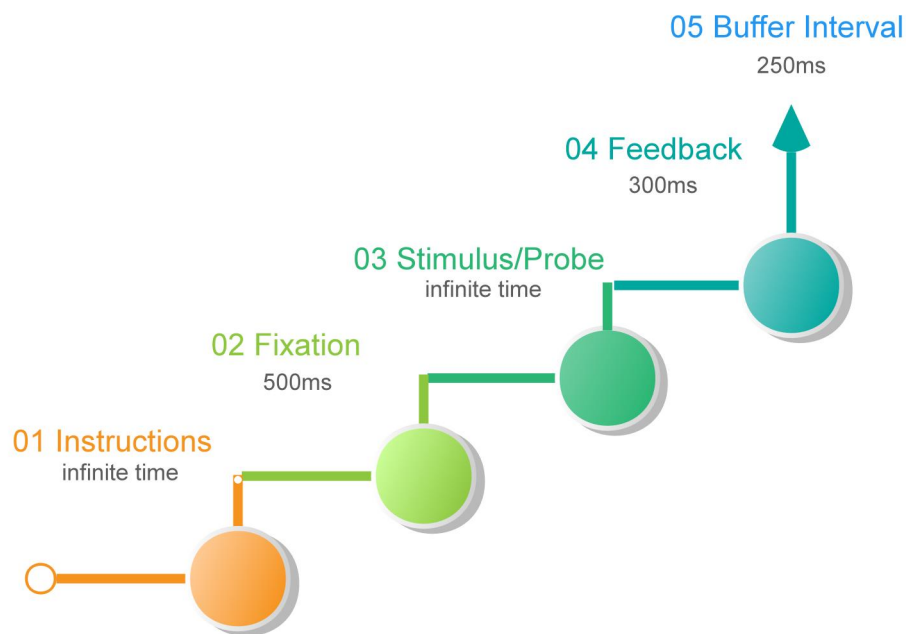

Figure3 The core experimental procedure of B1 in IAT1

Note: Although the core experimental procedure of other Blocks and B1 will be different, they are basically the same. Appendix XI shows the actual pages displayed on the computer screen corresponding to Figure 3.

3.2.6.2.7. IAT equipment and environment

In the IAT, the CPU of the computer is an Intel(R) Core (TM) i7-10700 running at a clock speed of 2.90GHz. Monitor resolution is 1920×1080. The IAT program was designed using E-prime 2.0 software. Additionally, the entire IAT was conducted in the psychology laboratory at Sichuan University of Engineering and Science in China. The laboratory has sufficient and consistent lighting, and the environment is quiet, making it suitable for testing purposes.

3.2.7. Data processing

The data collected in the current studies were processed using SPSS 28.0, Excel, and Amos 21.0 software. The statistical methods utilized included frequency analysis, one-sample t-test, one-tailed and two-tailed independent-sample t-test, one-way ANOVA, multi-way ANOVA, correlation analysis, multiple linear regression analysis, exploratory factor analysis, confirmatory factor analysis, and others.

3.2.8. Expected results

Using scales, IAT, and interviews to gather a substantial amount of data, six studies investigating gender stereotypes among CSGS college students were conducted and are presented in Table10. These six studies constitute the main part of this doctoral thesis.

3.2.9. Significance of the present studies

As mentioned above, previous studies have had limitations in terms of research objects, contents, and methods, and have been unable to answer the question of what kind of gender stereotypes CSGS college students actually have. Building on these previous studies, the present studies have made significant improvements in all aspects, aiming to conduct comprehensive and in-depth research on the gender stereotypes of CSGS college students, with the following two main research significance.

3.2.9.1. Theoretical significance

The present studies aim to explore the gender stereotypes of CSGS college students comprehensively and accurately. This will provide answers to questions about the specific gender stereotypes that CSGS college students hold, and it will confirm or falsify whether

CSGS college students have broken through traditional gender stereotypes. These findings will enrich the existing research in this field and expand people's understanding of gender stereotypes. Overall, the current studies seek to deepen our understanding of gender stereotypes among CSGS college students and contribute to the larger body of research on gender stereotypes.

To achieve a more comprehensive and thorough understanding of gender stereotypes among college students, a combination of direct and indirect measurement methods is proposed in the current studies. This approach aims to deepen the research in this field beyond what has been done in previous studies. Direct measurement involves collecting data directly from individuals through surveys, interviews, or observations. In the current studies, direct measurement will involve asking college students about their attitudes and beliefs regarding gender stereotypes. This method can provide valuable insights into the explicit biases and stereotypes held by individuals. Indirect measurement, on the other hand, involves assessing implicit stereotypes through measures such as IAT. These methods can reveal subconscious biases that individuals may not be aware of or may not be willing to disclose. By combining direct and indirect measures, the current studies will provide a more comprehensive understanding of gender stereotypes among college students. Overall, the proposed approach will allow for a more nuanced and thorough analysis of gender stereotypes among college students. By incorporating both direct and indirect measures, the current studies aim to deepen our understanding of these stereotypes and their impact on individuals and society.

In addition to using a combination of direct and indirect measures, the current studies will also aim to test for inconsistencies in previous research on gender stereotypes among college students. Specifically, I will explore the relationship between explicit stereotypes (as measured by self-report surveys) and implicit stereotypes (as measured by IAT). Previous studies have produced mixed results on this relationship, with some finding a strong correlation between explicit and implicit stereotypes, while others have found little to no correlation. Furthermore, I will also investigate the relationship between gender stereotypes and academic performance. Previous studies have produced conflicting results on this relationship, with some studies suggesting that gender stereotypes can negatively impact performance, while others have found no significant relationship. By doing so, I aim to provide a more conclusive

understanding of the relationship between explicit and implicit stereotypes, as well as the impact of gender stereotypes on performance. Overall, the current studies seek to advance the field of gender stereotype research by addressing previous inconsistencies and producing more reliable and accurate findings.

3.2.10. Practical significance

The practical value of the current studies lies in its potential to provide a cognitive basis for gender education and personality education among college students, as well as contribute to the construction of a social environment of gender equality.

By identifying specific gender stereotypes that are prevalent among CSGS college students, the current studies can provide information the development of targeted interventions aimed at challenging and reducing these stereotypes. These interventions can be integrated into existing gender education and personality education programs, providing college students with a more comprehensive understanding of gender stereotypes and their influence on individuals and society.

Additionally, the findings of the current studies may also inform the college feminist movement by highlighting specific gender stereotypes that are prevalent among CSGS college students. By raising awareness of these stereotypes and their negative effects, the current studies may help to mobilize support for the college feminist movement and contribute to the larger goal of promoting gender equality.

Finally, the outcomes of the current studies may also inform the construction of a social environment of gender equality by identifying specific gender stereotypes that are prevalent among CSGS college students. By addressing these stereotypes through targeted interventions and raising awareness of their negative effects, the current studies may contribute to the creation of a more inclusive and equitable social environment.

Overall, the practical value of the current studies lies in its potential to inform the development of interventions aimed at challenging and reducing gender stereotypes among college students, as well as contribute to the larger goal of promoting gender equality in society.

Table10 Expected research results

Study	Title	Object	Data sources	Hypothesis tested
1	The explicit gender stereotypes and sex role egalitarianism of the CSGS college students	Investigating the explicit gender stereotypes and sex role egalitarianism attitude of the CSGS college students and compare them with the SGS college students	Trait Gender Stereotypes Scale SRES-BB Explicit Subject Gender stereotypes Scale Explicit Math Gender Stereotypes Scale Explicit Language Gender stereotypes Scale	H1, H2,H3, H4, H5
2	The implicit gender stereotypes of the CSGS college students	Testing the implicit gender stereotypes of the CSGS college students through IAT and compare them with the SGS college students	IAT1, IAT2, IAT3	H6, H7, H8
3	The relationship between implicit and explicit gender stereotypes of the CSGS college students	Analyzing the relationship between implicit gender stereotypes and explicit gender stereotypes of the CSGS college students by using data statistical analysis method	Explicit Subject Gender Stereotypes Scale Explicit Math Gender Stereotypes Scale Explicit Language Gender Stereotypes Scale IAT2, IAT3	H9, H10
4	Math/language attitudes of the CSGS college students and their relationship with gender stereotypes	Analyzing the relationship among gender stereotypes and math/language attitudes, and explore the predictive ability of explicit gender stereotypes and implicit gender stereotypes on math/language attitudes	Trait Gender Stereotypes Scale Explicit Subject Gender Stereotypes Scale Explicit Math Gender Stereotypess Scale Explicit Language Gender Stereotypes Scale Explicit Math Attitude Scale Explicit Language Attitude Scale IAT1, IAT2, IAT3, IAT4	H11, H12, H13, H14

			Trait Gender Stereotypes Scale	
5	The relationship between gender stereotypes and math/English performance of the CSGS college students	Analyzing the relationship between gender stereotypes and math and English performance, and explore the predictive ability of explicit gender stereotypes and implicit gender stereotypes on math and English performance	Explicit Subject Gender Stereotypes Scale Explicit Math Gender Stereotypes Scale Explicit Language Gender Stereotype Scale IAT1, IAT2, IAT3 Math/English score of college entrance examination	H15, H16
<hr/>				
6	The role of math/language attitudes in the relationship between gender stereotypes and math/language performance	Analyzing the relationship among gender stereotypes, math/English performance and math/language attitudes, and explore whether math/English attitude plays a mediator role.	Explicit Math Gender Stereotypes Scale Explicit Language Gender Stereotypes Scale Explicit Math Attitude Scale Explicit Language Attitude Scale IAT1, IAT2, IAT3, IAT4 Math/English score of college entrance examination	H17, H18

4. The Explicit Gender Stereotypes and Sex Role Egalitarianism of CSGS College Students

4.1. Research purpose

The explicit gender stereotypes and sex role egalitarianism of the CSGS college students will be investigated and compared with the SGS college students. Among them, explicit gender stereotypes include explicit trait gender stereotypes, explicit subject gender stereotypes, explicit math gender stereotypes and explicit language gender stereotypes. This study will answer what explicit gender stereotypes and sex role egalitarianism attitude the CSGS college students have.

4.2. Research hypothesis

This study will verify the first 5 of the 18 research hypotheses, which are:

H1: The top 5 words used by the CSGS college students to describe male and female traits are fundamentally different from those of the SGS college students;

H2: Compared with the SGS college students, the CSGS college students have a stronger sex role egalitarianism attitude;

H3: Compared with the SGS college students, the explicit subject gender stereotypes of the CSGS college students are weaker;

H4: Compared with the SGS college students, the explicit math gender stereotypes of the CSGS college students are weaker;

H5: Compared with the SGS college students, the explicit language gender stereotypes of the CSGS college students are weaker;

4.3. Participants

The number and gender of the participants are shown in Table 5.

4.4. Instruments

The instruments needed in this study have been introduced in the previous article, including the following:

- a) Trait Gender Stereotypes Scale
- b) Sex Role Egalitarianism Scale-BB (SRES-BB)
- c) Explicit Subject Gender Stereotypes Scale (ESGS)
- d) Explicit Math Gender Stereotypes Scale (EMGS)
- e) Explicit Language Gender Stereotypes Scale (ELGS)

4.5. Research procedure

With the permission of the course instructor, the participants underwent a group testing session in class. The questionnaire was distributed electronically through the network, with the researcher displaying a QR code that participants scanned using their mobile phones to access and answer the questions. A total of 368 participants scanned and filled out the questionnaire, out of which 356 valid questionnaires were retrieved, resulting in an overall response rate of 96.73%.

4.6. Data processing

The data collected in this study were analyzed using SPSS 28.0 software. Based on the research hypothesis and data conditions, this study mainly conducted descriptive statistics, one-sample t-test, one-tailed and two-tailed independent-sample t-test, one-way ANOVA, and multi-way ANOVA.

4.7. Results

4.7.1. Descriptive statistics for each explicit scale

The results of descriptive statistics for SRES-BB, explicit subject gender stereotypes, explicit math stereotypes, and explicit language stereotypes are presented in Table 11.

Table 11 Descriptive statistics for each explicit scale

	N	Min	Max	Mean	SD
SRES-BB	345	27	89	40.83	11.133
ESGS	345	10	50	28.84	11.014
EMGS	345	11	35	18.26	6.444
ELGS	345	11	51	20.44	6.968

Note: ESGS=Explicit Subject Gender Stereotypes; EMGS=Explicit Math Gender Stereotypes; ELGS=Explicit Language Gender Stereotypes Scale.

4.7.2. Explicit trait gender stereotypes of the CSGS college students

In this study, a total of 356 scales measuring trait gender stereotypes were collected. Each

scale comprised of 5 male trait words and 5 female trait words, resulting in a total of 1780 male trait words and 1780 female trait words. After removing invalid words and merging synonyms, a final tally of 1713 words associated with male traits and 1730 words associated with female traits were obtained.

4.7.2.1. Explicit male trait gender stereotypes of the CSGS college students

The frequency of 1713 male trait words was analyzed to identify the most commonly used male trait words and their corresponding frequency rankings. The top five words with the highest frequency were selected, and a comparison was made between the choices of CSGS and SGS college students. The results are presented in Table12.

Table12 Comparison of explicit male trait words between the CSGS and the SGS college students

	Total participants n=1713	CSGS college students n=615	SGS college Students n=1098
1	Responsible (8.06%)	Responsible (8.46%)	Responsible (7.83%)
2	Cheerful (5.08%)	Brave (5.69%)	Cheerful (5.37%)
3	Strong (5.08%)	Strong (5.04%)	Strong (5.10%)
4	Brave (4.20%)	Cheerful (4.55%)	Manly (3.73%)
5	Manly (3.56%)	Handsome (3.90%)	Brave (3.37%)
Total	25.98%	27.64%	25.40%

Note: n refers to the number of words, not the number of participants.

Table12 displays the top five high-frequency words chosen by all participants, which are "responsible", "cheerful", "strong", "brave", and "manly", accounting for 25.98% of the responses. For CSGS college students, the top five words are "responsible", "brave", "strong", "cheerful", and "handsome", accounting for 27.64%. For SGS college students, the top five words are "responsible", "cheerful", "strong", "manly", and "brave", accounting for 25.40%. Overall, all participants considered "responsible", "cheerful", "brave", and "strong" as

important traits of men, with "responsible" being the top choice. The difference lies in CSGS college students choosing "handsome" while SGS college students choosing "manly".

4.7.2.2. Explicit female trait gender stereotypes of the CSGS college students

The frequency of 1730 female trait words was analyzed to identify the most commonly used female trait words and their corresponding frequency rankings. The top five words with the highest frequency were selected, and a comparison was made between the choices of CSGS and SGS college students. The results are presented in Table13.

Table13 Comparison of explicit female trait words between the CSGS and the SGS college students

	Total participants n=1730	CSGS college students n=615	SGS college Students n=1115
1	Tender (12.08%)	Tender (12.34%)	Tender (11.93%)
2	Beautiful (10.64%)	Beautiful (10.92%)	Beautiful (11.03%)
3	Meticulous (6.53%)	Meticulous (8.29%)	Kind (6.10%)
4	Kind (6.01%)	Kind (5.85%)	Meticulous (5.56%)
5	Lovely (4.27%)	Lovely (3.90%)	Lovely (4.48%)
Total	39.53%	41.30%	39.10%

Note: n refers to the number of words, not the number of participants.

Table13 displays the results for the top five high-frequency words of female traits. For all participants, the words are "tender", "beautiful", "meticulous", "kind" and "lovely", which account for 39.53% of the responses. Among CSGS college students, the same words appear with "Tender" as the first trait, followed by "Beautiful", "Meticulous", "Kind" and "Lovely", accounting for 41.30% of responses. Similarly, among SGS college students, the top five traits are "tender", "beautiful", "kind", "meticulous" and "lovely", accounting for 39.10% of responses. Overall, all participants consider these five traits to be the most important traits of women, with "tender" being the most highly ranked. The only difference between the CSGS

college students and SGS college students is the order of "kind" and "meticulous".

The results suggest that there is not much difference between the CSGS college students and the SGS college students in terms of their selection and ranking of male and female traits.

Thus, H1 has not been confirmed.

4.7.3. Sex role egalitarianism of the CSGS college students

4.7.3.1. Comparison of SRES-BB between the CSGS and the SGS college students

To verify whether the CSGS college students have a stronger attitude towards sex role egalitarianism than the SGS college students, it is necessary to analyze the total score of SRES-BB and the scores of each factor (marital roles, parental roles, social-interpersonal-heterosexual roles, employment roles, and educational roles) and compare them with those of the SGS college students. The results are presented in Table14.

Table14 Comparison of SRES-BB and its factors between the CSGS and the SGS college students (M±SD)

	SRES-BB	MR	PR	ER	SIHR	EduR
CSGS college Students n=124	41.72±10.76	7.65±2.78	11.81±3.00	10.68±2.12	9.06±3.87	5.87±1.89
SGS college Students n=232	40.65±11.55	7.38±2.63	11.66±2.79	10.34±2.10	8.87±3.96	5.88±2.07
t	.850	.932	.448	1.444	.453	-.019
P	.198	.176	.327	.075	.325	.492

Note:MR=Marital Roles; PR=Parental Roles; ER=Employment Roles;

SIHR=Social-Interpersonal-Heterosexual Roles; EduR=Educational Roles. Similarly hereinafter.

The SRES-BB scale is also scored using the Likert 5-point scale, with 1 representing "very disagree", and 5 representing "very agree", and a total of 25 questions. The score range of the total scale is 25-125, and the score range of each factor is 5-25. The lower the score, the greater the recognition of sex role egalitarianism and the stronger the sex role equality attitude.

From Table14, it can be observed that the CSGS college students' total score and 5 factors score are not lower than those of the SGS college students, and there is no significant difference between them. Thus, H2 has not been confirmed.

4.7.3.2. One-sample t-test of SRES-BB and its factors

If consider the middle option "not sure" of the 5-point Likert scale as a neutral option with a score of 3, then the scores indicate that the participants' attitudes are neither biased towards traditional sex roles nor anti-traditional sex roles. One-sample t-tests was conducted for the SRES-BB total score and median score (75) and for the factor score and median score (15). The results are presented in Table15.

Table15 One-sample t-test of SRES-BB and its factors

	CSGS college Students(n=124)		SGS college Students(n=232)	
	t	Cohen d	t	Cohen d
SRES-BB (median =75)	-34.431***	-3.092	-45.300***	-2.974
MR (median=15)	-29.436***	-2.643	-44.124***	-2.897
PR (median=15)	-11.852***	-1.064	-18.215***	-1.196
ER (median=15)	-23.800***	-2.137	-33.836***	-2.221
SIHR (median=15)	-17.063***	-1.532	-23.571***	-1.548
EduR (median=15)	-60.269***	-5.412	-67.295***	-4.418

Note: ***=P<.001.

It can be seen from the Table15 that both the CSGS and the SGS college students have statistically significant differences from the median value in terms of SRES-BB total score and 5 factors, with a huge effect size.

4.7.3.3. Influence of various variables on SRES-BB

To further investigate the influence of sex, major, residence, and their interaction on SRES-BB, a multi-way ANOVA was conducted. The results are presented in Table16.

Table 16 Multi-way ANOVA of SRES-BB

	SS	df	MS	F	P	$\eta^2_{partial}$
Sex	14456.622	1	14456.622	195.163***	<.001	.367
Major	401.331	1	401.331	5.418*	.021	.016
Residence	118.640	1	118.640	1.602	.207	.005
Sex*Major	642.795	1	642.795	8.678**	.003	.025
Sex*Residence	5.931	1	5.931	.080	.777	.000
Major*Residence	77.701	1	77.701	1.049	.306	.003
Sex*Major*Residence	2.829	1	2.829	.038	.845	.000

Note: *=P<.05; **=P<.01; ***=P<.001.

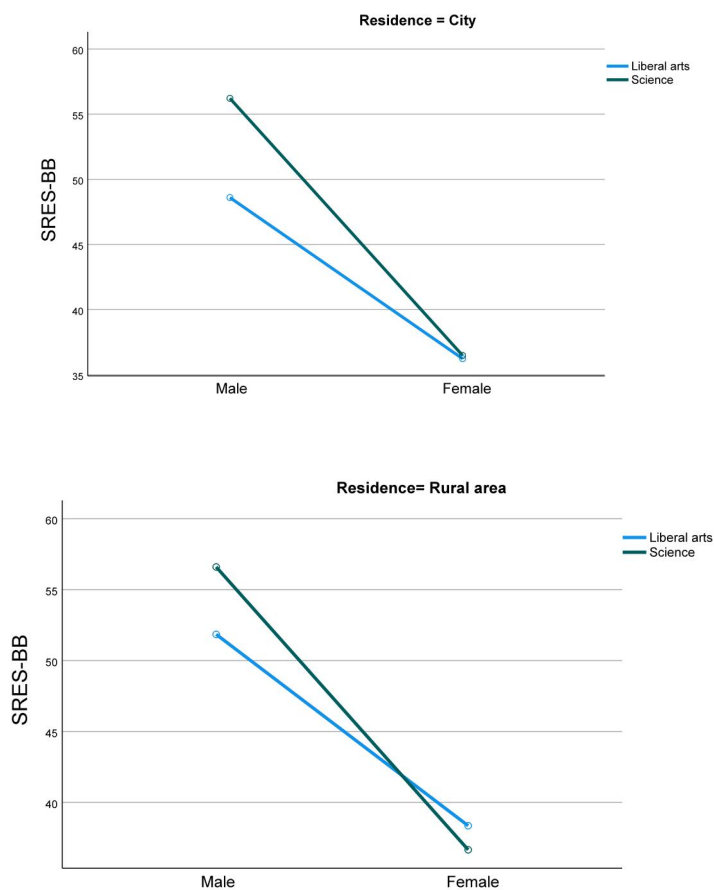

Figure 4 Effects of sex, major, residence and their interaction on SRES-BB

The results presented in Table16 indicate that the main effect of sex ($F=195.163$, $P<.001$, $\eta^2_{\text{partial}}=.367$) and major ($F=5.418$, $P=.021$, $\eta^2_{\text{partial}}=.016$) are statistically significant, while the main effects of residence is not significant. Furthermore, the interaction effect of sex*major ($F=8.678$, $P=.003$, $\eta^2_{\text{partial}}=.025$) is significant, and that of other variables are also not significant. These findings suggest that both sex and major have a significant influence on the SRES-BB, and there is a significant interaction effect between sex and major. However, residence does not have a significant effect on the SRES-BB. A lower score on the SRES-BB indicates a greater tendency toward sex role equality. As shown in Figure4, college students majoring in science have higher scores than those majoring in liberal arts, regardless of their place of residence. This finding suggests that college students in science tend to have more unequal gender role attitudes and more traditional gender role beliefs compared to college students in liberal arts. Additionally, Female college students also exhibit significantly lower SRES-BB scores compared to their male counterparts, indicating a stronger awareness and inclination toward sex role equality among female students in comparison to male students. Specifically, the interaction effect between sex and major is evident in that female college students in science, as members of the CSGS college students, exhibit a stronger inclination toward sex role equality compared to female college students in liberal arts.

4.7.3.4. Further exploration of the influence of sex and major on SRES-BB

To further investigate the potential influence of sex and major on SRES-BB, the combination of major and sex variables was divided into four groups: liberal arts male, liberal arts female, science male, and science female. The average score of the four groups of college students on the SRES-BB is shown in Figure5.

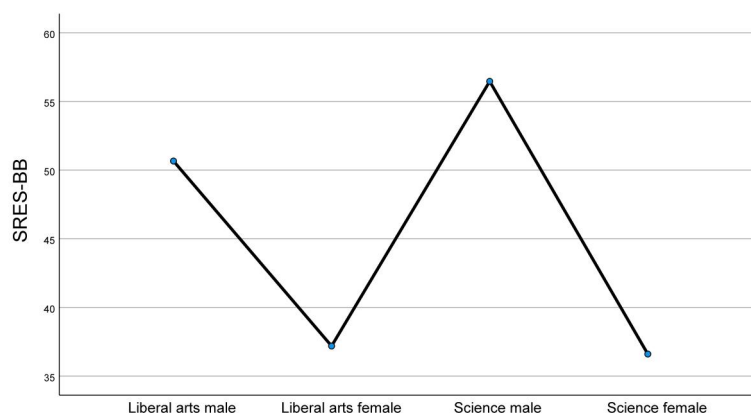

Figure5 Average score of SRES-BB of four groups college students

One-way ANOVA and multiple comparisons were conducted on their scores, and the results are presented in Table17 and Table18, respectively.

Table17 One-way ANOVA of SRES-BB

	M±SD		SS	df	MS	Welch F	P	η ²
Liberal arts male	50.66±10.999	Between	17365.542	3	5788.514	47.762***	<.001	.407
Liberal arts female	37.19±7.972	Within	25274.041	341	74.117			
Science male	56.46±12.343	Total	42639.583	344				
Science female	36.60±6.057							

Note: ***=P<.001.

Table17 shows significant differences in SRES-BB scores among the four groups of college students (Welch F=47.762, P<.001, η²=.407). To further compare these differences, multiple comparisons were conducted, and the results are presented in Table18.

Table18 Multiple comparisons (Games-Howell) of four groups college students' SRES-BB

		Mean Difference	SE	P
	Liberal arts female	13.471*	1.814	<.001
Liberal arts male	Science male	-5.803	2.619	.128
	Science female	14.056*	1.850	<.001

	Liberal arts male	-13.471*	1.814	<.001
Liberal arts female	Science male	-19.274*	2.061	<.001
	Science female	.585	.900	.916

	Liberal arts male	5.803	2.619	.128
Science male	Liberal arts female	19.274*	2.061	<.001
	Science female	19.859*	2.092	<.001

	Liberal arts male	-14.056*	1.850	<.001
Science female	Liberal arts female	-.585	.900	.916
	Science male	-19.859*	2.092	<.001

Note: *The mean difference is significant at the 0.05 level.

The results of the multiple comparisons reveal that science female have significantly lower SRES-BB scores compared to liberal arts male as well as science male. Additionally, liberal arts female also exhibit significantly lower SRES-BB scores compared to liberal arts male and science male. Although science female has lower SRES-BB scores than liberal arts female, the difference does not reach statistical significance. Based on the ranking of SRES-BB scores, the order from high to low is: science male>liberal arts male>liberal arts female>science female. This implies that sex role equality attitudes are most strongly endorsed for female individuals in science, while male individuals in the science are the least likely to endorse them.

4.7.4. Explicit subject gender stereotypes of the CSGS college students

4.7.4.1. Comparison of explicit subject gender stereotypes between the CSGS and the SGS college students

In order to verify whether the explicit subject gender stereotypes of the CSGS college students are weaker than that of the SGS college students, it is necessary to analyze the scores of the 4 sub-scales, ESGS index and ECSGS index, and compare with the SGS college students. The results are shown in Table19.

Table19 Comparison of explicit subject gender stereotypes between the CSGS and the SGS college students (M±SD)

	ESMGS	ELMGS	ESFGS	ELFGS	ESGS Index	ECSGS Index
CSGS college Students n=124	11.91 ± 6.21	11.99 ± 6.11	14.15 ± 6.16	14.97 ± 6.50	26.88 ± 11.34	26.14 ± 10.92
SGS college Students n=232	13.18 ± 6.35	14.09 ± 6.12	15.49 ± 5.95	16.72 ± 6.10	29.90 ± 10.84	29.57 ± 11.15
t	-1.881*	-3.078**	-2.002*	-2.516**	-2.463**	-2.790**
P	.035	.001	.023	.006	.007	.003
Cohen d	.201	.342	.223	.280	.274	.310

Note: *= $P < .05$; **= $P < .01$.

ESMGS=Explicit Science Male Gender Stereotypes; ELMGS=Explicit Liberal Arts Male Gender Stereotypes; ESFGS=Explicit Science Female Gender Stereotypes; ELFGS=Explicit Liberal Arts

Female Gender Stereotypes.

Table 19 reveals that the CSGS college students show complexity and surprise in explicit subject gender stereotypes. Sub-scale 1 measures the participants' recognition of male's suitability for science and engineering. The score of the CSGS college students is lower than that of the SGS college students, and reaches a significant level, indicating that the CSGS college students have a lower agreement of male's suitability for science and engineering than the SGS college students. This difference is statistically significant ($t=-1.881$, $P=.035$), with an effect size of .201.

Sub-scale 2 measures the participants' recognition of male's suitability for liberal arts. The score of the CSGS college students is also lower than that of the SGS college students, and reaches a significant level, indicating that the CSGS college students have a lower agreement of male's suitability for liberal arts than the SGS college students, and it is statistically significant ($t=-3.078$, $P=.001$). Its size of effect is .342.

Sub-scale 3 measures the participants' recognition of female's suitability for science and engineering. The score of the CSGS college students is also lower than that of the SGS college students, and reaches a significant level, indicating that the CSGS college students have a lower agreement of female's suitability for science and engineering than the SGS college students, and it is statistically significant ($t=-2.002$, $P=.023$). Its size of effect is .223.

Sub-scale 4 measures the participants' recognition of female's suitability for liberal arts. The score of the CSGS college students is also lower than that of the SGS college students, and reaches a significant level, indicating that the CSGS college students have a lower agreement of female's suitability for liberal arts than the SGS college students, and it is statistically significant ($t=-2.516$, $P=.006$). Its size of effect is .280.

The ESGS Index is the sum of the scores of sub-scale 1 and sub-scale 4. The higher the index is, the more the participants agree with the subject gender stereotypes that men are suitable for science and engineering, and women are suitable for liberal arts. The index of the CSGS students is lower than that of the SGS students, and it reaches a significant level, indicating that the degree of agreement of the CSGS students to subject gender stereotypes is lower than that of the SGS students, which is statistically significant ($t=-2.463$, $P=.007$). Its effect size

is.274. Thus, H3 has been confirmed.

ECSGS Index is the sum of the scores of sub-scale 2 and sub-scale 3. The higher the index is, the more the participants agree with the counter subject gender stereotypes that men are suitable for liberal arts, and women are suitable for science and engineering. The index of the CSGS students is lower than that of the SGS students, and it reaches a significant level, indicating that the degree of agreement of the CSGS students to counter subject gender stereotypes is lower than that of the SGS students, which is statistically significant ($t=-2.790$, $P=.003$). Its effect size is .310.

4.7.4.2. One-sample t-test of explicit subject gender stereotypes and its sub-scales

A one-sample t-test was conducted to compare the scores on the explicit subject gender stereotypes scale with their median values. The results are presented in Table20.

Table20 One-sample t-test of explicit subject gender stereotypes and its sub-scales

	CSGS college Students(n=124)		SGS college Students(n=232)	
	t	Cohen d	t	Cohen d
ESMGS (median=15)	-5.538***	-.497	-4.363***	-.286
ELMGS (median=15)	-5.482***	-.492	-2.275**	-.149
ESFGS (median=15)	-1.546	-.139	1.246	.082
ELFGS (median=15)	-.055	-.005	4.282***	.281
ESGS Index (median=30)	-3.006**	-.275	-.145	-.010
ECSGS Index (median=30)	-3.939***	-.354	-.583	-.038

Note: **= $P<.01$; ***= $P<.001$.

ESMGS=Explicit Science Male Gender Stereotypes; ELMGS=Explicit Liberal Arts Male Gender Stereotypes; ESFGS=Explicit Science Female Gender Stereotypes; ELFGS=Explicit Liberal Arts Female Gender Stereotypes.

It is evident that the scores of the CSGS college students on ESMGS, ELMGS, ESGS index, and ECSGS index are significantly lower than the median, although the effect size is small.

The scores on ESFGS and ELFGS are also lower than the median, but the difference is not statistically significant. On the other hand, the scores of the SGS college students on ESMGS, ELMGS, and ELFGS are significantly lower than the median, but the effect size is also small. The difference between the scores of ESFGS, ESGS index, and ECSGS index, and the median is not statistically significant.

4.7.4.3. Influence of various variables on ESGS index

To investigate the influence of sex, major, residence, and their interaction on ESGS index, a multi-way ANOVA was conducted. The results are presented in Table21 and Figure6.

Table21 Multi-way ANOVA of ESGS index

	SS	df	MS	F	P	$\eta^2_{partial}$
Sex	1037.852	1	1037.852	8.878**	.003	.026
Major	9.482	1	9.482	.081	.776	.000
Residence	31.418	1	31.418	.269	.605	.001
Sex*Major	628.569	1	628.569	5.377*	.021	.016
Sex*Residence	2.150	1	2.150	.018	.892	.000
Major*Residence	100.989	1	100.989	.864	.353	.003
Sex*Major*Residence	25.966	1	25.966	.222	.638	.001

Note: *=P<.05; **=P<.01.

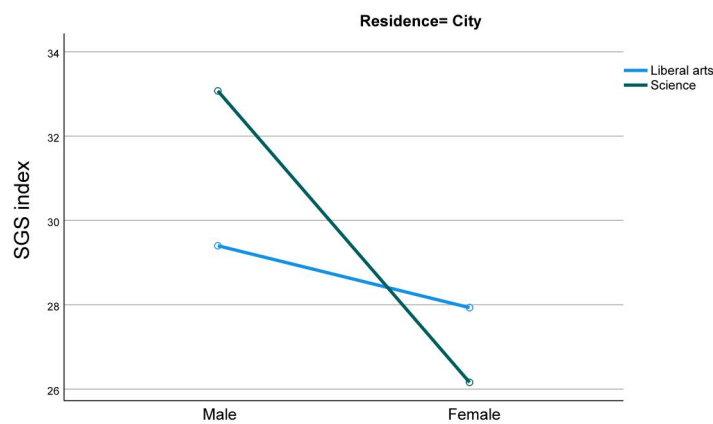

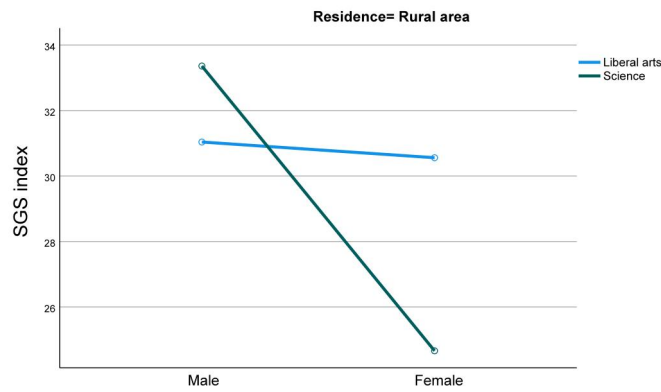

Figure6 Effects of sex, major, residence and their interaction on ESGS index

The results presented in Table21 indicate that the main effect of sex ($F=8.878$, $P=.003$, $\eta^2_{\text{partial}}=.026$) is statistically significant, while the main effects of residence and major are not significant. Furthermore, the interaction effect of sex*major ($F=5.377$, $P=.021$, $\eta^2_{\text{partial}}=.015$) is significant, and that of other variables are also not significant. These findings suggest that sex has a significant impact on the ESGS index, and there is a significant interaction effect between sex and major. However, residence does not have a significant effect on the ESGS index. ESGS index refers to an index that measures the degree of agreement with the notion that male are more suited to science and female are more suited to liberal arts. A higher ESGS index indicates a stronger endorsement of this gender stereotyped belief. As shown in Figure6, female college students exhibit significantly lower ESGS index compared to their male counterparts, indicating female college students have a lower level of endorsement of subject gender stereotypes compared to male college students. Specifically, the interaction between sex and major is manifested such that while science male exhibits a high level of endorsement of subject gender stereotypes, science female, as member of the CSGS college students, show the opposite pattern.

4.7.4.4. Further exploration of the influence of sex and major on ESGS index

To further explore the possible impact of sex and major on ESGS index, the combination of major and sex variables was divided into four groups, namely liberal arts male, liberal arts female, science male, and science female. The average scores of these four groups of college students on the ESGS index are presented in Figure7. A one-way ANOVA and LSD multiple comparisons were performed on their scores, as shown in Table22 and Table23.

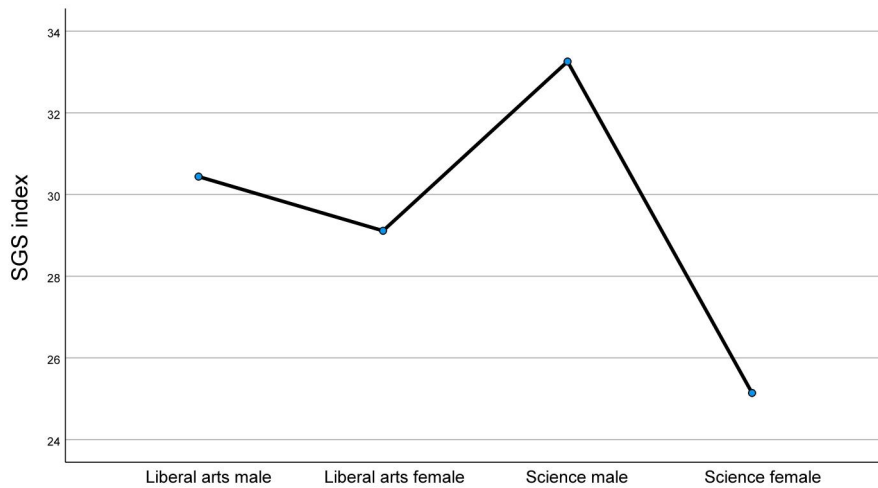

Figure7 Average score of ESGS index of four groups college students

Table22 One-way ANOVA of ESGS index

	M±SD		SS	df	MS	F	P	η^2
Liberal arts male	30.44±10.948	Between Groups	1946.608	3	648.869	5.562***	<.001	.047
Liberal arts female	29.11±11.009							
Science male	33.26±8.914	Within Groups	39779.624	341	116.656			
Science female	25.14±11.014							
		Total	41726.232	344				

Note: ***=P<.001.

Table22 shows significant differences in ESGS index among the four groups of college students ($F=5.562$, $P<.001$, $\eta^2=.047$). To further compare these differences, LSD multiple comparisons were conducted, and the results are presented in Table23.

Table23 shows that significant differences exist in ESGS index between liberal arts female and science male, as well as between science female and science male. The four groups of college students are ranked from low to high as follows: science female<liberal arts male<liberal arts female<science male, indicating that female in science exhibit the lowest level of adherence to subject gender stereotypes, while science male have the highest level of adherence to such gender stereotypes.

Table23 Multiple comparisons of four groups college students' ESGS index

		Mean Difference	SE	P
	Liberal arts female	1.327	1.890	.896
Liberal arts male	Science male	-2.817	2.227	.588
	Science female	5.298	2.119	.067

	Liberal arts male	-1.327	1.890	.896
Liberal arts female	Science male	-4.144	1.639	.065
	Science female	3.971*	1.489	.042

	Liberal arts male	2.817	2.227	.588
Science male	Liberal arts female	4.144	1.639	.065
	Science female	8.115*	1.899	<.001

	Liberal arts male	-5.298	2.119	.067
Science female	Liberal arts female	-3.971*	1.489	.042
	Science male	-8.115*	1.899	<.001

Note: *The mean difference is significant at the 0.05 level.

4.7.5. Explicit math gender stereotypes of the CSGS college students

4.7.5.1. Comparison of explicit math gender stereotypes between the CSGS and the SGS college students

To understand the explicit math gender stereotypes of the CSGS college students, the math gender stereotype scores of the CSGS college students and the SGS college students are compared. At the same time, according to Song (2014), the explicit math gender stereotype scale mainly detects the extent to which the participants agree with the idea that "female are less capable in mathematics than male" from both positive and negative aspects. The answer options are: very disagree, disagree, not sure, agree, and very agree, with 1-5 points respectively. The lower the score, the more participants did not agree with math gender stereotypes, the less they agree that girls have lower math abilities than boys. Taking "not

sure" (3 points) as the standard, there are 11 items in the entire scale, so a one-sample t-test can be done based on the score of 33. If the score of the participants is significantly lower than 33, it means that the participants do not agree that the math ability of female is not as good as that of male. If it is significantly higher than 33, it means that the participants agree that the math ability of female is not as good as that of male. The results are shown in Table24.

Table24 Comparison of explicit math gender stereotypes between the CSGS and the SGS college students (M±SD)

	EMGS	n	t (median =33)	Cohen d
CSGS college Students	18.48 ± 6.25	124	-25.868***	2.323
SGS college Students	18.35 ± 6.72	232	-33.215***	2.181
t	.179			
P	.429			

Note: ***=P<.001.

Table24 shows that, there is no significant difference in the scores of the CSGS college students and the SGS college students on explicit math gender stereotypes, indicating that the CSGS college students have no weaker math gender stereotypes than the SGS college students (t=.179, P=.429). Thus, H4 has not been confirmed. At the same time, the scores of both are lower than 33, which is statistically significant (t=-25.868; t=-33.215), and the effect size has also reached a high level (Cohen d=2.323; Cohen d=2.181), indicating that neither thinks that female's math ability is worse than male's.

4.7.5.2. Influence of various variables on explicit math gender stereotypes

To investigate the influence of sex, major, residence, and their interaction on participants' explicit math gender stereotypes, a multi-way ANOVA was conducted. The results are presented in Table25 and Figure8.

Table25 Multi-way ANOVA of explicit math gender stereotypes

	SS	df	MS	F	P	$\eta^2_{partial}$
Sex	3358.054	1	3358.054	114.183***	<.001	.253
Major	141.467	1	141.467	4.810*	.029	.014
Residence	132.915	1	132.915	4.519*	.034	.013
Sex*Major	334.381	1	334.381	11.370***	<.001	.033
Sex*Residence	7.628	1	7.628	.259	.611	.001
Major*Residence	58.044	1	58.044	1.974	.161	.006
Sex*Major*Residence	42.466	1	42.466	1.444	.230	.004

Note: *=P<.05;***=P<.001.

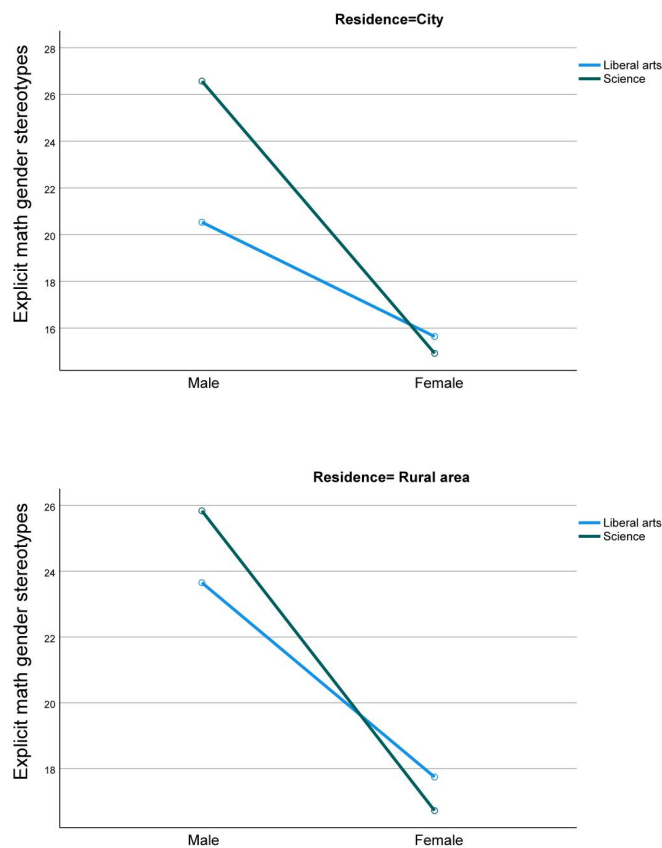

Figure8 Effects of sex, major, residence and their interaction on explicit math gender stereotypes

The results indicate that the main effect of sex is significant ($F=114.183, P<.001, \eta^2_{\text{partial}}=.253$), as well as the major ($F=4.810, P=.029, \eta^2_{\text{partial}}=.014$) and residence ($F=4.519, P=.034, \eta^2_{\text{partial}}=.013$). Combining with Figure8, it can be seen that female college students have significantly lower scores on explicit math gender stereotypes than male college students, liberal arts college students have significantly lower scores on explicit math gender stereotypes than science students, and city college students have significantly lower scores on explicit math gender stereotypes rural college students. Higher scores on explicit math gender stereotypes indicate greater agreement that math is a masculine subject, and therefore, female college students, liberal arts college students, and city college students are less likely to identify math as a male domain than male college students, science college students, and rural college students. Furthermore, the interaction effect of sex*major is also significant, which manifests itself in that if, for example, liberal arts male college students score lower on explicit math gender stereotypes than science male college students, the opposite is true for female college students in liberal arts and science.

4.7.5.3. Further exploration of the influence of sex and major on explicit math gender stereotypes

To further investigate the potential influence of sex and major on explicit math gender stereotypes, the combination of major and sex variables was divided into four groups: liberal arts male, liberal arts female, science male, and science female. The average score of the four groups of college students on the explicit math gender stereotypes is shown in Figure9. One-way ANOVA and LSD multiple comparisons were conducted on their scores, and the results are presented in Table26 and Table27, respectively.

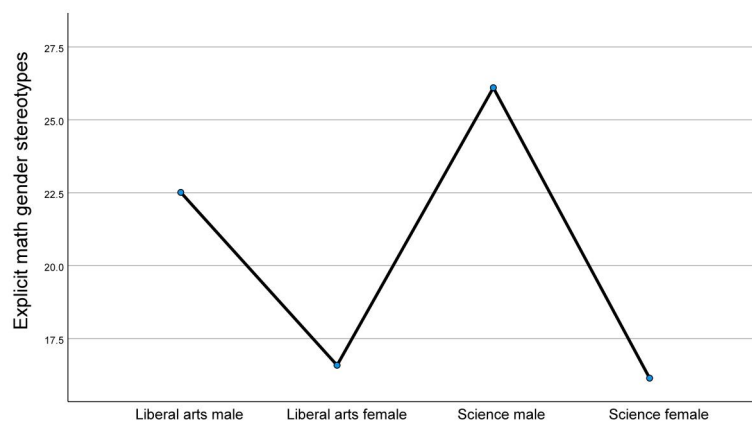

Figure9 Average score of explicit math gender stereotypes of four groups college students

Table26 One-way ANOVA of explicit math gender stereotypes

	M±SD		SS	df	MS	Welch F	P	η^2
Liberal arts male	22.51±6.329	Between Groups	4016.249	3	1338.750	33.067***	<.001	.281
Liberal arts female	16.58±5.234	Within Groups	10266.748	341	30.108			
Science male	26.10±6.750	Total	14282.997	344				
Science female	16.14±4.885							

Note: ***=P<.001.

Table26 shows significant differences in explicit math gender stereotypes scores among the four groups of college students (Welch F=33.067, P<.001, η^2 =.281).

Table27 Multiple comparisons (Games-Howell) of four groups college students' explicit math gender stereotypes

		Mean Difference	SE	P
	Liberal arts female	5.929*	1.060	<.001
Liberal arts male	Science male	-3.590	1.465	.076
	Science female	6.371*	1.133	<.001

	Liberal arts male	-5.929*	1.060	<.001
Liberal arts female	Science male	-9.520*	1.147	<.001
	Science female	.442	.673	.913

	Liberal arts male	3.590	1.465	.076
Science male	Liberal arts female	9.520*	1.147	<.001
	Science female	9.962*	1.214	<.001

	Liberal arts male	-6.371*	1.133	<.001
Science female	Liberal arts female	-.442	.673	.913
	Science male	-9.962*	1.214	.000

Note: *The mean difference is significant at the 0.05 level.

The results of the multiple comparisons reveal that science female have significantly lower explicit math gender stereotypes scores compared to liberal arts male as well as science male. Additionally, liberal arts female also exhibits significantly lower explicit math gender stereotypes scores compared to liberal arts male and science male. Although science female has lower explicit math gender stereotypes scores than liberal arts female, the difference does not reach statistical significance. Based on the ranking of explicit math gender stereotypes scores, the order from high to low is: science male>liberal arts male>liberal arts female>science female. This means that science female least agree that math is a male subject, while science male most agree.

4.7.6. Explicit language gender stereotypes of the CSGS college students

4.7.6.1. Comparison of explicit language gender stereotypes between the CSGS and the SGS college students

To understand the explicit language gender stereotypes of the CSGS college students, the explicit language gender stereotype scores of the CSGS college students and the SGS college students are compared. the explicit language gender stereotype scale mainly detects the extent to which the participants agree with the idea that "male are less capable in language than female" from both positive and negative aspects. The answer options are: very disagree, disagree, not sure, agree, and very agree, with 1-5 points respectively. The lower the score, the more participants did not agree with language gender stereotypes, the less they agree that boys have lower language abilities than girls. Taking "not sure" (3 points) as the standard, there are 11 items in the entire scale, so a one-sample t-test can be done based on the score of 33. If the score of the participants is significantly lower than 33, it means that the participants do not agree that the language ability of male is not as good as that of female. If it is significantly higher than 33, it means that the participants agree that the language ability of male is not as good as that of female. The results are shown in Table28.

Table28 Comparison of explicit language gender stereotypes between the CSGS and the SGS college students (M±SD)

	ELGS	n	t (median =33)	Cohen d
CSGS college Students	20.56±7.31	124	-18.944***	1.701
SGS college Students	20.45±6.86	232	-27.891***	1.831
t	.139			
P	.445			

Note: ***=P<.001.

Table28 shows that, there is no significant difference in the scores of the CSGS college students and the SGS college students on explicit language gender stereotypes, indicating that the CSGS college students have no weaker explicit language gender stereotypes than the SGS college students (t=.139, P=.445). Thus, H5 has not been confirmed. At the same time, the scores of both are lower than 33, which is statistically significant (t=-18.944; t=-27.891), and both the effect size have also reached a very high level (Cohen d=1.701; Cohen d=1.831), indicating that neither thinks that male's language ability is worse than female's.

4.7.6.2. Influence of various variables on explicit language gender stereotypes

Table29 Multi-way ANOVA of explicit language gender stereotypes

	SS	df	MS	F	P	$\eta^2_{partial}$
Sex	1198.101	1	1198.101	27.845***	P<.001	.076
Major	285.032	1	285.032	6.624**	.010	.019
Residence	185.050	1	185.050	4.301*	.039	.013
Sex*Major	221.105	1	221.105	5.139*	.024	.015
Sex*Residence	2.610	1	2.610	.061	.806	.000
Major*Residence	1.306	1	1.306	.030	.862	.000
Sex*Major*Residence	.248	1	.248	.006	.940	.000

Note: *=P<.05; **=P<.01; ***=P<.001.

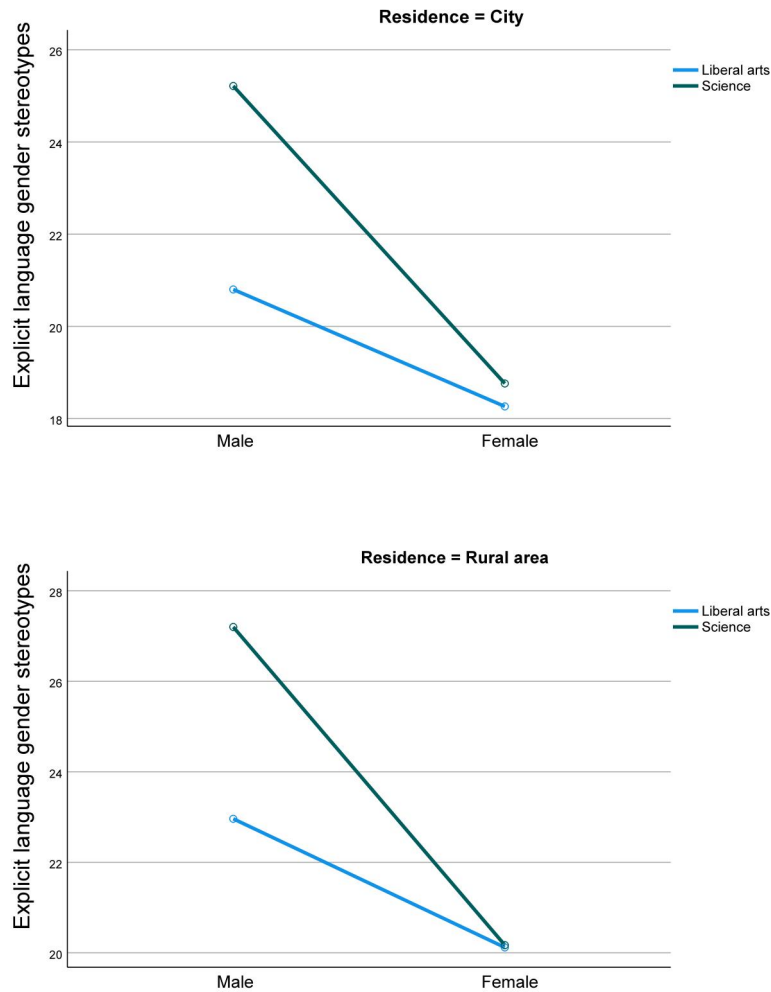

Figure10 Effects of sex, major, residence and their interaction on explicit language gender stereotypes

To investigate the influence of sex, major, residence, and their interaction on participants' explicit language gender stereotypes, a multi-way ANOVA was conducted. The results are presented in Table29 and Figure10. The results indicate that the main effect of sex is significant ($F=27.845$, $P<.001$, $\eta^2_{\text{partial}} = .076$), as well as the major ($F=6.624$, $P=.010$, $\eta^2_{\text{partial}} = .019$) and residence ($F=4.301$, $P=.039$, $\eta^2_{\text{partial}} = .013$). Combining with Figure10, it can be seen that female college students have significantly lower scores on explicit language gender stereotypes than male college students, liberal arts college students have significantly lower scores on explicit language gender stereotypes than science students, and city college students have significantly lower scores on explicit language gender stereotypes rural college students. Higher scores on explicit language gender stereotypes indicate greater agreement that

language is a feminine subject, and therefore, female college students, liberal arts college students, and city college students are less likely to identify language as a female domain than male college students, science college students, and rural college students. Furthermore, the interaction effect of sex*major ($F=5.139$, $P=.024$, $\eta^2_{\text{partial}}=.015$) is also significant, which manifests itself in that if, for example, liberal arts male college students score lower on explicit language gender stereotypes than science male college students, then there is no such significant trend for female college students in liberal arts and science.

4.7.6.3. Further exploration of the influence of sex and major on explicit language gender stereotypes

To further investigate the potential influence of sex and major on explicit language gender stereotypes, the combination of major and sex variables was divided into four groups: liberal arts male, liberal arts female, science male, and science female. The average score of the four groups of college students on the explicit language gender stereotypes is shown in Figure 11.

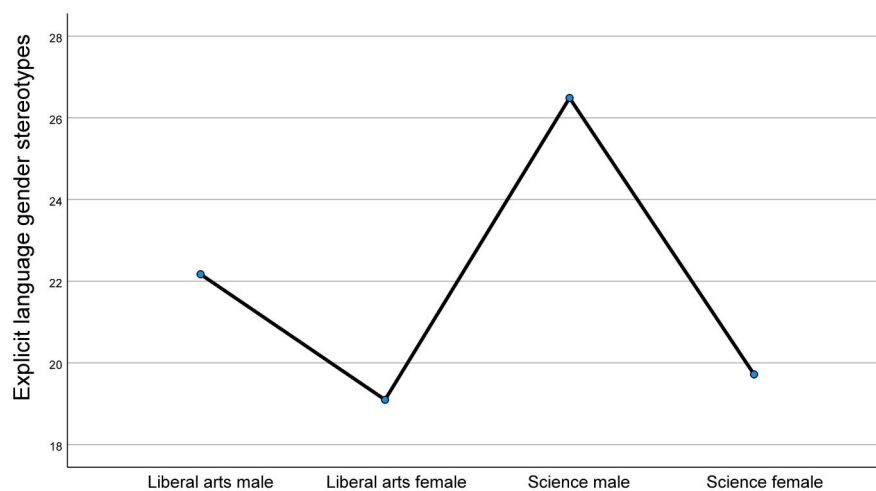

Figure 11 Average score of explicit language gender stereotypes of four groups college students

One-way ANOVA and multiple comparisons were conducted on their scores, and the results are presented in Table 30 and Table 31, respectively.

Table30 One-way ANOVA of explicit language gender stereotypes

	M±SD		SS	df	MS	Welch F	P	η ²
Liberal arts male	22.17±6.811	Between Groups	1927.299	3	642.433	16.035***	<.001	.115
Liberal arts female	19.10±6.196	Within Groups	14773.611	341	43.324			
Science male	26.49±6.244	Total	16700.910	344				
Science female	19.72±7.469							

Note: ***=P<.001.

Table31 Multiple comparisons (Games-Howell) of four groups college students' explicit language gender stereotypes

		Mean Difference	SE	P
	Liberal arts female	3.074*	1.156	.049
Liberal arts male	Science male	-4.316*	1.460	.021
	Science female	2.453	1.359	.278

	Liberal arts male	-3.074*	1.156	.049
Liberal arts female	Science male	-7.391*	1.098	<.001
	Science female	-.622	.959	.916

	Liberal arts male	4.316*	1.460	.021
Science male	Liberal arts female	7.391*	1.098	<.001
	Science female	6.769*	1.310	<.001

	Liberal arts male	-2.453	1.359	.278
Science female	Liberal arts female	.622	.959	.916
	Science male	-6.769*	1.310	<.001

Note: *The mean difference is significant at the 0.05 level.

Table 30 shows significant differences in explicit language gender stereotypes scores among the four groups of college students (Welch $F=16.035$, $P<.001$, $\eta^2=.115$). The results of the multiple comparisons reveal that liberal arts female have significantly lower explicit language gender stereotypes scores compared to liberal arts male as well as science male. In particular, science male scored significantly higher in explicit language gender stereotypes than science female, liberal arts male and liberal arts female. Additionally, liberal arts male also exhibits significantly lower explicit language gender stereotypes scores compared to science male. Although liberal arts female has lower explicit language gender stereotypes scores than science female, the difference does not reach statistical significance. Based on the ranking of explicit language gender stereotypes scores, the order from high to low is: science male > liberal arts male > science female > liberal arts female. This means that liberal arts female least agree that language is a female subject, while science male most agree.

4.8. Discussion

4.8.1. Explicit trait gender stereotypes of the CSGS college students

When reviewing the research on explicit trait gender stereotypes of college students, it can be found that college students in China and other countries have relatively consistent views on female traits and male traits: men are generally considered strong, rational, brave, capable, and so on, while women are considered weak, emotional, nagging, gentle, and so on (Bergen & Williams, 1991; Hosoda & Stone, 2000; Piatek-Jimenez et al., 2018; Qian et al., 1999). This trait gender stereotype is believed to have maintained a certain stability for a long time (Bergen & Williams, 1991; Lueptow et al., 1995). However, previous studies did not focus on the CSGS college students. What is the trait gender stereotype of the CSGS college students? Is it different from the SGS college students? This is an important issue of this study. Different from the adjective checklist method commonly used in previous studies, this study adopts the free response method, hoping to give participants more room to respond and let them freely reflect their views on male and female traits, although its data processing is more difficult and cumbersome.

The results of this study shows that for all participants, the top five high-frequency words for men are "responsible", "cheerful", "strong", "brave" and "manly", and the top five high-frequency words for women are "tender", "beautiful", "meticulous", "kind" and "lovely".

The results are slightly different when compared with other studies on trait gender stereotypes of Chinese college students. The research on trait gender stereotypes of Chinese college students has long existed. Qian et al. (1999) shows that most Chinese college students think that men are stronger and capable than women in thinking, ability and work, such as "clarity of thinking" and "achievement motivation"; Women surpass men in some emotional items, such as "understanding" and "valuing feelings", which appear passive and submissive. The results of other studies are also consistent with this, finding that college students believed that the most important personality characteristics of men were creativity, humor, self-reliance, optimism and competence and the most important personality characteristics of a woman are kindness, gentleness, considerate, obedient(Qin & Yu, 2001; Xu, 2003). However, in this study, the result of college students' free response is that the most important trait of men is "responsible". This is relatively rare in previous studies of Chinese college students (this is also relatively rare in foreign studies), which needs attention. Responsibility refers to what should be done within the scope of duty. In fact, men should be responsible, which is not so much the description of male traits by college students as the expectation of men. In China's traditional Confucian culture, it has always been emphasized that gentlemen should take corresponding responsibilities. A gentleman has corresponding responsibilities for himself, family, society and the country(Deng, 2009; Ren, 2008). In this study, participants believe that the most important trait of men is responsible, which is consistent with Chinese traditional Confucian culture. While the responsibility is not prominent in previous studies, it is particularly prominent in this study, perhaps because this study uses the free response method to collect male and female trait words, while previous studies mostly use the method of scale or adjective checklist. The biggest problem of scale or adjective checklist is that participants can only choose from given options, depending on the researcher's design of the options, participants cannot react freely. This study adopts the free response method, which allows participants to fill in what they think are male trait words and female trait words. Of course, this is only a guess, and the real reason is worth exploring. However, it is suggested that in future studies, more free response methods should be used to truly reflect the views and attitudes of participants.

How to explain the formation of trait gender stereotypes? Zuo (2015) believed that, in

traditional Chinese culture, both sexes are required to abide by strict gender role norms. In a society where the level of productivity is low and human beings live mainly by manual labor, women are indeed weak. Female have weak bones, and the absolute length of upper and lower limbs is shorter than that of male. The soft tissues of female are fatty, loose and weak. In terms of physical strength, it is a fact that males are strong and females are weak. The superiority of men in physical strength puts them in the main position in production, and naturally obtains the power to manage social affairs. Based on the worship and pursuit of power, human beings have long formed such a psychological stereotype: men must create wealth, manage society, control the situation, and protect women, and they must be strong, intelligent, calm and rational. This is the male social role archetype. And weak, gentle, beautiful, hardworking, humble and respectful, full of love have become the image patterns of women that seem to be difficult to change. This image of women appears as a weak person. Society sees women as weak, and women acquiesce themselves as weak and have to depend on others and be protected by others. Because males are strong and females are weak, so "men dominate outside, women dominate inside".

The final question is whether research hypothesis is proved. The five male trait words that the CSGS college students fill in most frequently are "responsible", "brave", "strong", "cheerful" and "handsome", and for the SGS college students, these words are "responsible", "cheerful", "strong", "manly" and "brave". Meanwhile, the five female trait words that the CSGS college students fill in most frequently are "tender", "beautiful", "meticulous", "kind" and "lovely", and for the SGS college students, they also fill in these words, but the order is different. In general, there is no special reason to believe that there are fundamental differences between the CSGS and the SGS college students in their views on male and female traits. Thus, H1 has not been confirmed.

4.8.2. Sex role egalitarianism of the CSGS college students

Since the CSGS college students have chosen a major opposite to the subject gender stereotype, are they gender role egalitarians compared with the SGS college students? This is also the focus of this study. From the data analysis results in Table14, there is no significant difference between the CSGS college students and the SGS college students in SRES-BB total score and its 5 factors score. This means that even if the CSGS college students choose a

major that is inconsistent with the subject gender stereotypes, it does not mean that they are more gender role egalitarian than the SGS college students. Thus, H2 has not been confirmed. Although the CSGS college students do not show a greater tendency towards sex role egalitarianism than the SGS college students in general, the definition of CSGS college students as those who are studying in fields opposite to the subject gender stereotypes. Therefore, this study further explores the impact of sex and majors on sex role egalitarianism. It is found that students in liberal arts majors tend to be more supportive of gender role egalitarianism than students in science majors, and female students tend to be more supportive of gender role egalitarianism than male students. Therefore, contrary to the research hypothesis, the current study finds that the participant's performance on gender equality is determined not by whether they are CSGS college students, but rather by their major and sex, especially sex. In our society, women are often part of a group with lower status, lower income, and fewer privileges, and thus stand to gain more from an egalitarian society compared to a society where men have higher status, higher income, and more privileges. Therefore, women are often more likely to be advocates of gender role egalitarianism compared to men. There are many studies that indicate that women are more likely to support sex role equality (Anderson & Johnson, 2003; Beere et al., 1984; Berkel, 2004), and the current study clearly continues to support this conclusion.

However, in terms of SRES-BB total score and 5 factors, the scores of both the CSGS and the SGS college students are significantly lower than the median value, and the size of effect is huge. This shows that the CSGS college students and the SGS college students strongly do not agree with traditional sex roles. This is consistent with other previous research results. Previous research found that most Chinese college students are opposed to the traditional sex role of men and women, such as "men should focus on career and women should focus on family" (Zhang, 2014). A comparative study between China and the United States found that compared with Americans, Chinese college students have stronger attitudes towards gender equality in family domain and weaker attitudes towards gender equality in work domain, but there is no difference in other aspects of sex role equality (Zhang et al., 2002). In China, although the traditional sex roles still have a great impact, the impact on the new generation of young people, especially college students, is becoming increasingly insignificant. This has

much to do with the improvement of the status of Chinese women in the past half century. Taking education as an example, the literature shows that as early as 2013, the proportion of female students in junior high school in China was 46.7%, the proportion of female students in senior high school was 50.0%, the proportion of female college students was 52.1%, the proportion of female postgraduate students was 51.6%, and the proportion of female doctoral students was 36.9%. The gap between male and female students in education was significantly narrowed(Tan, 2016). The gender role equality awareness of Chinese college students is not only the embodiment of the vigorous development of China's gender equality cause, but also will affect the further development of China's gender equality cause. Even so, it is also possible that this tendency towards sex role egalitarianism among the CSGS and the SGS students in the present study is due to the demand characteristics and self-presentation artifacts, which needs to be noticed.

4.8.3. Explicit subject gender stereotypes of the CSGS college students

In general, the CSGS college students have mixed performance on explicit subject gender stereotypes. Their scores are significantly lower than that of the SGS college students in sub-scale 1, sub-scale 4 and ESGS index, although the size of effect is not particularly large. It means that compared with the SGS college students, the CSGS college students are less in favor of subject gender stereotypes, that is, men are suitable for science and engineering, and women are suitable for liberal arts. Thus, their subject gender stereotypes were weaker than those of the SGS college students, and H3 has been confirmed. Meanwhile, sex has been found to have an impact on explicit subject gender stereotypes, with female college students being less likely to endorse subject gender stereotypes compared to male college students. As CSGS college students, science female has the lowest level of endorsement of subject gender stereotypes. Sex once again plays an important role in gender stereotypes.

However, the scores of CSGS college students are also significantly lower than that of the SGS college students in sub-scale 2, sub-scale 3 and ECSGS index, which means that compared with the SGS college students, the CSGS college students are less in favor of the view that women are suitable for science and engineering, and men are suitable for liberal arts. This suggests that disapproval of subject gender stereotypes does not imply approval of opposites. These two are independent.

What is more interesting is that Table 20 shows that both the CSGS and the SGS college students have significantly lower scores on sub-scale 1 and sub-scale 2 than the median value, reaching statistical significance, and the effect size is also relatively high, but the scores of sub-scale 3 and 4 are either lower than the median, but the difference is not statistically significant, or higher than the median. This means that both the CSGS and the SGS college students agree that men are not suitable for science and engineering or liberal arts, and that is not the case for women. This phenomenon echoes the research on sex differences in academic performance in recent years. Although some studies have given the opposite conclusion, many studies still have found that women's academic achievements gradually surpass those of men, which is considered as one of the manifestations of the reversal of gender gap in education (Chee et al., 2005; Marcenaro–Gutierrez et al., 2018; Van Bavel et al., 2018). Women have higher GPA than men (Chee et al., 2005). Even some studies have found that women are significantly better than men in math, Chinese, physics, chemistry and English all subjects (Yu, 2016). Whether the college students in this study have a more positive evaluation of women is based on the excellent performance of women's academic achievements in recent years, or for other reasons, which needs further discussion.

In addition, it should be noted that both the CSGS and the SGS college students scored lower than the median on the ESGS index, indicating that they did not recognize the subject gender stereotypes, which is inconsistent with many current research results. In fact, many current studies have found that college students generally believe that men are suitable for science and engineering, and women are suitable for liberal arts (Guimond & Roussel, 2001; Brian A Nosek et al., 2007; Nosek et al., 2009). However, this conclusion is based on many studies that use IAT as an indirect measurement to measure subject gender stereotypes. Meanwhile, some studies have found that if both direct measurement and detection measurement are used, there may be experimental dissociation, that is, in the direct measurement, participants deny the subject gender stereotypes, but in the indirect measurement, they connect science and engineering with men, liberal arts with women closely (Cai et al., 2001; He & Liu, 2007). Direct measurement may be affected by demand characteristics and self-presentation artifacts, which is the reason why this study will use IAT to study gender stereotypes in the future.

4.8.4. Explicit math gender stereotypes of the CSGS college students

The scores of the CSGS and the SGS students on explicit math gender stereotypes are significantly lower than the median value of 33, which means that they do not recognize the advantages of male students over female students in mathematics, which is not consistent with explicit math gender stereotypes. This research result is consistent with the previous research results of junior and senior high school students in China using the same scale. According to Song (2014), there is no explicit math gender stereotype among Chinese students from junior one to senior three, while the present study also found that there is no explicit math gender stereotype among Chinese college students. But many studies also found that college students generally believe that males are better at math than females, and math is more closely related to men (Cai et al., 2001; Ma & Liang, 2006, 2008; Nosek et al., 2002; Smeding, 2012; Xie et al., 2022). However, some of these studies mostly use indirect measurements such as IAT or SEB. Therefore, the difference in research results is likely due to the difference in measurement methods. A further proof is that, according to Song (2014), although the score of explicit math gender stereotypes is very low, the participants closely link math and men in the IAT of implicit math gender stereotypes, indicating an experimental dissociation. Therefore, it is very necessary to further study participants' implicit math gender stereotypes through indirect measurement.

However, the present study is more concerned about whether the explicit math gender stereotype of the CSGS college students is weaker than that of the SGS college students. The data shows that this is not the case. The CSGS students scored higher than the SGS students in explicit math gender stereotypes, although it did not reach a statistically significant level. Therefore, H4 has not been confirmed. Meanwhile, sex also has been found to have an impact on explicit math gender stereotypes, with female college students being less likely to endorse math gender stereotypes explicitly compared to male college students. As CSGS college students, science female has the lowest level of endorsement of math gender stereotypes. Sex once again plays an important role in gender stereotypes.

4.8.5. Explicit language gender stereotypes of the CSGS college students

Like explicit math gender stereotypes, the scores of the CSGS and the SGS students on explicit language gender stereotypes are also significantly lower than the median value of 33, which means that they do not recognize the advantages of female students over male students

in language, which is not consistent with explicit language gender stereotypes. Many previous studies have confirmed the existence of explicit language gender stereotypes among college students (Chaffee, Lou, & Noels, 2020; Chaffee, Lou, Noels, et al., 2020; Guimond & Roussel, 2001), but the results of this study contradict this, and the reasons need to be further explored. However, the CSGS students scored higher than the SGS students in explicit language gender stereotypes, although they did not reach a statistically significant level. Therefore, H5 has not been confirmed. Meanwhile, sex also has been found to have an impact on explicit language gender stereotypes, with female college students being less likely to endorse language gender stereotypes explicitly compared to male college students. As CSGS college students, science female has the lowest level of endorsement of explicit language gender stereotypes. Sex once again plays an important role in gender stereotypes.

4.9. Conclusion

- a) Although the words used to describe the characteristics of men and women in the top five of the CSGS college students are different from those of the SGS college students in terms of individual words or order, there is no essential difference between the two. H1 has not been confirmed.
- b) There is no significant difference between the CSGS college students and the SGS college students in SRES-BB total score and each factor score. Thus, compared with the SGS college students, the CSGS college students do not have a stronger sex role egalitarianism attitude. H2 has not been confirmed. However, both the CSGS and the SGS college students do not agree with traditional sex roles, but agree with sex role egalitarianism. Sex has a significant impact on sex role egalitarianism, with women being more likely to endorse sex role egalitarianism than men, especially science female who are members of the CSGS college students, while science male have the lowest level of endorsement.
- c) The scores of the CSGS college students are significantly lower than that of the SGS college students in sub-scale 1, sub-scale 4 and ESGS index. Thus, compared with the SGS college students, the explicit subject gender stereotypes of the CSGS college students are weaker. H3 has been confirmed. Sex also has a significant impact on explicit subject gender stereotypes, with women being less likely to endorse subject gender stereotypes than men, especially science female who are members of the CSGS college students,

while science male has the highest level of endorsement.

- d) The CSGS students scored higher than the SGS students in explicit math gender stereotypes, although they did not reach a statistically significant level. Thus, compared with the SGS college students, the explicit math gender stereotypes of the CSGS college students are not weaker. H4 has not been confirmed. Sex has a significant impact on explicit math gender stereotypes, with women being less likely to endorse math gender stereotypes than men, especially science female who are members of the CSGS college students, while science male has the highest level of endorsement. However, both the CSGS and the SGS college students have low recognition of math gender stereotypes.
- e) The CSGS students scored higher than the SGS students in explicit language gender stereotypes, although they did not reach a statistically significant level. Thus, compared with the SGS college students, the explicit language gender stereotypes of the CSGS college students are not weaker. H5 has not been confirmed. Sex has a significant impact on explicit subject gender stereotypes, with women being less likely to endorse language gender stereotypes than men, especially liberal arts female, while science male has the highest level of endorsement. However, both the CSGS and the SGS college students have low recognition of language gender stereotypes.

5. The Implicit Gender Stereotypes of the CSGS College Students

5.1. Research purpose

The implicit gender stereotypes of the CSGS college students will be tested and compared with the SGS college students. Among them, implicit gender stereotypes include implicit trait gender stereotypes, implicit subject gender stereotypes, implicit math/language gender stereotypes. This study will answer what implicit gender stereotypes the CSGS college students have.

5.2. Research hypothesis

This study will verify 3 of the 18 research hypotheses, which are:

H6: Compared with the SGS college students, the implicit trait gender stereotypes of the CSGS college students are weaker;

H7: Compared with the SGS college students, the implicit subject gender stereotypes of the CSGS college students are weaker;

H8: Compared with the SGS college students, the implicit math/language gender stereotypes of the CSGS college students are weaker;

5.3. Participants

Table32 Composition of IAT participants

	the CSGS college students		the SGS college students	
	Male	Female	Male	Female
Math		62	27	
Chinese language and literature	32			42

From the Table5, participants are randomly selected for IAT, and the final composition of participants for IAT is shown in the Table32. IAT is more time-consuming and labor-intensive than general psychological tests. Therefore, it is unlikely to conduct large-scale IAT unless it is conducted on the Internet, and there are many interference factors that may affect the collected data online. Thus, this study is not conducted online, but in the psychological laboratory. The

number of participants' samples is relatively small compared with the scale test. However, this sample size is not small in IAT. It should be noted that when processing IAT data, some participant data will be deleted (Greenwald et al., 2022; Greenwald et al., 2003). Therefore, it is normal that the number of participants of each IAT will be different.

5.4. Instruments

The instruments needed in this study have been introduced in the previous article, including the following:

- a) IAT of implicit trait gender stereotypes (IAT1)
- b) IAT of implicit subject gender stereotypes (IAT2)
- c) IAT of implicit math/language gender stereotypes (IAT3)

See Appendix IX for the target categories, attribute categories and items of the IAT1, IAT2, IAT3.

5.5. Research procedure

All participants were invited to carry out IAT in the psychology laboratory of Sichuan University of Science and engineering, China. About 30 people will be tested at the same time. The participants who finish the test first can leave psychology laboratory quietly. Only after all the participants in the same group have finished the test, can the test of another group of participants begin. The researcher should explain the requirements of the experimental operation to each group of participants before starting the test.

5.5.1. Procedure of IAT1

See Table 7 for the task of 7 blocks of IAT1. In order to further explain its procedures, the actual instruction of IAT1 will be presented below which guide all the behaviors and procedures of participants. See the appendix X for the actual computer screen.

Step 1: General instruction

You will complete a word classification task. The words belonging to each category are listed below. These words will be displayed in the middle of the screen one by one. Your task is to determine which category the word belongs to by pressing the key. This part will take about 7 or 8 minutes.

Notice:

Every word can be classified into a certain category, and most of them are easy to classify.

If you respond too slowly, the data may lose value. Please try your best to be fast and correct.

It is normal that a quick response may lead to a small number of errors.

For best results, avoid distractions and keep focus. Press SPACEBAR to start.

Step 2: Instruction of B1

Place your forefinger on the E key and the I key of the keyboard (please always use these two fingers). The "male" and "female" on the top of the screen are categories, and the words to be classified will be presented in the center of the screen one by one. When the words presented belong to the left male, press the E key with the left forefinger; When the words presented belong to the right female, press the I key with the right forefinger. Please respond as quickly and accurately as possible. Too slow response or too many errors will lead to inaccurate results. Press SPACEBAR to start.

Step 3: Instruction of B2

Notice: The above categories have changed, and the words to be classified will also change, but the rules will not change. When the words presented belong to the left masculine words, press the E key; When the presented words belong to the right feminine words, press the I key. Please respond as quickly and accurately as possible. Press SPACEBAR to start.

Step 4: Instruction of B3

Notice: The four categories previously presented separately now appear together. When the words presented belong to the left male or masculine words, please press the E key; When the words presented belong to the right female or feminine words, please press the I key. Please respond as quickly and accurately as possible. Press SPACEBAR to start.

Step 5: Instruction of B4

According to the previous rules, do it again! Press SPACEBAR to start.

Step 6: Instruction of B5

Notice: There are only two categories above, but the positions are interchanged. Press E key when the words presented belong to the left feminine words; Press the I key When the presented words belong to the right masculine words. Please respond as quickly and accurately as possible. Press SPACEBAR to start.

Step 7: Instruction of B6

Notice: The four categories above appear in a new combination. When the words presented belong to the left male or feminine words, press the E key; When the words presented belong to the right female or masculine words, press the I key. Please respond as quickly and accurately as possible. Press SPACEBAR to start.

Step 8: Instruction of B7

According to the previous rules, do it again! Press SPACEBAR to start.

Step 8: Instruction of B7

Thank you for your participation! Please take a break and wait for the researcher to arrange!

5.5.2. Procedure of IAT2

The procedures and instruction of IAT2 are basically the same as those of IAT1. The tasks of each block are shown in Table33.

Table33 Task of 7 Blocks in the IAT2

Block	No.of trials	Function	Task	Items assigned to left-key response	Items assigned to right-key response
1	20	Practice	Initial target categories classification	Items of male	Items of female
2	20	Practice	Initial attribute categories classification	Items of science	Items of liberal arts
3	20	Practice	Initial combined task(compatible)	Items of male Items of science	Items of female Items of liberal arts
4	40	Test	Initial combined task(compatible)	Items of male Items of science	Items of female Items of liberal arts
5	30	Practice	Reversed attribute categories classification	Items of liberal arts	Items of science
6	20	Practice	Reversed combined task(incompatible)	Items of male Items of liberal arts	Items of female Items of science
7	40	Test	Reversed combined task(incompatible)	Items of male Items of liberal arts	Items of female Items of science

5.5.3. Procedure of IAT3

The procedures and instruction of IAT3 are basically the same as those of IAT1. The tasks of each block are shown in Table34.

Table34 Task of 7 Blocks in the IAT3

Block	No.of trials	Function	Task	Items assigned to left-key response	Items assigned to right-key response
1	20	Practice	Initial target categories classification	Items of male	Items of female
2	20	Practice	Initial attribute categories classification	Items of math	Items of language
3	20	Practice	Initial combined task(compatible)	Items of male Items of math	Items of female Items of language
4	40	Test	Initial combined task(compatible)	Items of male Items of math	Items of female Items of language
5	30	Practice	Reversed attribute categories classification	Items of language	Items of math
6	20	Practice	Reversed combined task(incompatible)	Items of male Items of language	Items of female Items of math
7	40	Test	Reversed combined task(incompatible)	Items of male Items of language	Items of female Items of math

5.6. Data processing

For all the collected latency data, it is first necessary to eliminate trials with latency > 10,000ms and subjects for whom more than 10% of trials have latency less than 300ms. Then use the self-made Excel program to calculate the IAT effect value, namely D value. The specific calculation process is shown in the Table4. Data statistics are completed using SPSS28.0 and Excel software. According to the research hypothesis and data, this study mainly carries out the one-sample t-test and one-tailed and two-tailed independent-sample t-test, one-way ANOVA and multi-way ANOVA.

5.7. Results

5.7.1. Descriptive statistics for IAT1, IAT2 and IAT3

The descriptive statistical results of IAT1, IAT2 and IAT3 are shown in Table35.

Table35 Descriptive statistics of IAT1, IAT2 and IAT3

	N	Min	Max	Mean	SD
IAT1	162	-3.088	2.901	.246	.407
IAT2	161	-2.515	2.397	.195	.346
IAT3	161	-2.314	3.441	.204	.398

5.7.2. Implicit trait gender stereotypes of the CSGS college students

5.7.2.1. Comparison of implicit trait gender stereotypes between the CSGS and the SGS college students

To understand the implicit trait gender stereotypes of the CSGS college students, the D value of implicit trait gender stereotype of the CSGS college students and that of the SGS college students are compared. At the same time, according to Greenwald et al. (2022), an attitude IAT's zero point means absence-of-preference. If the $D < 0$, it means the latency of incompatible combined tasks (Male+Feminine and Female+Masculine) are shorter than that of compatible combined tasks (Male+Masculine and Female+Feminine). If $D > 0$, it means the latency of incompatible combined tasks are longer than that of compatible combined tasks. So, it can also use 0 as the test value to conduct a one-sample t-test on the D values of IAT1 of the CSGS and the SGS college students. The results are shown in Table36.

Table36 Comparison of implicit trait gender stereotypes between the CSGS and the SGS college students (M±SD)

	Implicit trait gender Stereotypes	n	t (median=0)	Cohen d
CSGS college Students	.27 ± .36	94	7.378***	.761
SGS college Students	.21 ± .37	68	3.690***	.447
t	.970			
P	.167			

Note: ***=P<.001.

It shows that, there is no significant difference in the D values of the CSGS college students and the SGS college students on implicit trait gender stereotypes ($t=.970$, $P=.167$), indicating that the CSGS college students have no weaker implicit trait gender stereotypes than the SGS college students. Thus, H6 has not been confirmed. At the same time, the D values of both are higher than 0, which are statistically significant ($t=7.378$; $t=3.690$), and both the effect size have also reached a not low level ($d=.761$; $d=.447$), indicating that both are all inclined to the combination of male with masculinity, and female with femininity.

5.7.2.2. Influence of various variables on implicit trait gender stereotypes

To further investigate the influence of sex, major, residence, and their interaction on implicit trait gender stereotypes, a multi-way ANOVA was conducted. The results are presented in Table37 and Figure12.

Table37 Multi-way ANOVA of IAT1

	SS	df	MS	F	P	$\eta^2_{partial}$
Sex	.983	1	.983	6.232*	.014	.039
Major	.004	1	.004	.022	.881	.000
Residence	.030	1	.030	.189	.664	.001
Sex*Major	.170	1	.170	1.075	.301	.007
Sex*Residence	.422	1	.422	2.673	.104	.017
Major*Residence	.001	1	.001	.009	.923	.000
Sex*Major*Residence	.262	1	.262	1.661	.199	.011

Note: *= $P<.05$.

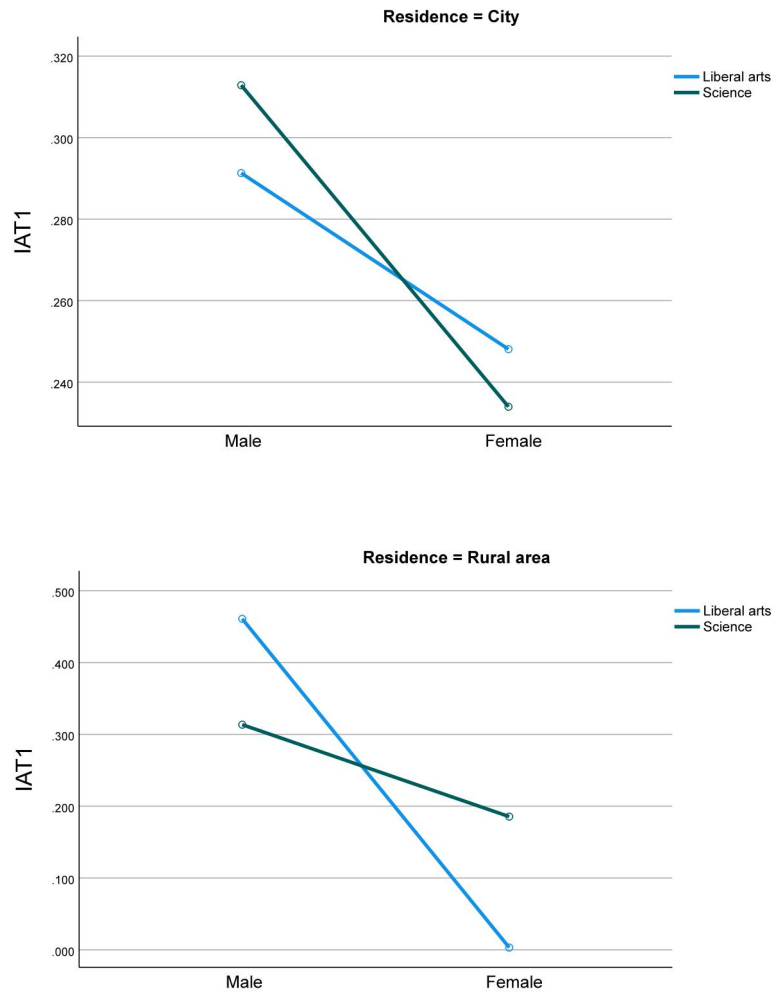

Figure12 Effects of sex, major, residence and their interaction on IAT1

The results indicate that the only main effect of sex ($F=6.232$, $P=.014$, $\eta^2_{\text{partial}}=.039$) is statistically significant, suggesting that sex has a significant impact on the IAT1. A higher D value on IAT1 indicates a stronger association between male and masculine traits, female and feminine traits. As shown in Figure12, female college students exhibit significantly lower IAT1 scores compared to their male counterparts, indicating a weaker association between male and masculine traits and female and feminine traits among female college students in comparison to male college students.

5.7.2.3. Further exploration of the influence of sex and major on implicit trait gender stereotypes

To further investigate the potential influence of sex and major on implicit trait gender stereotypes, the combination of major and sex variables was divided into four groups: liberal

arts male, liberal arts female, science male, and science female. The average score of the four groups of college students on the IAT1 is shown in Figure13.

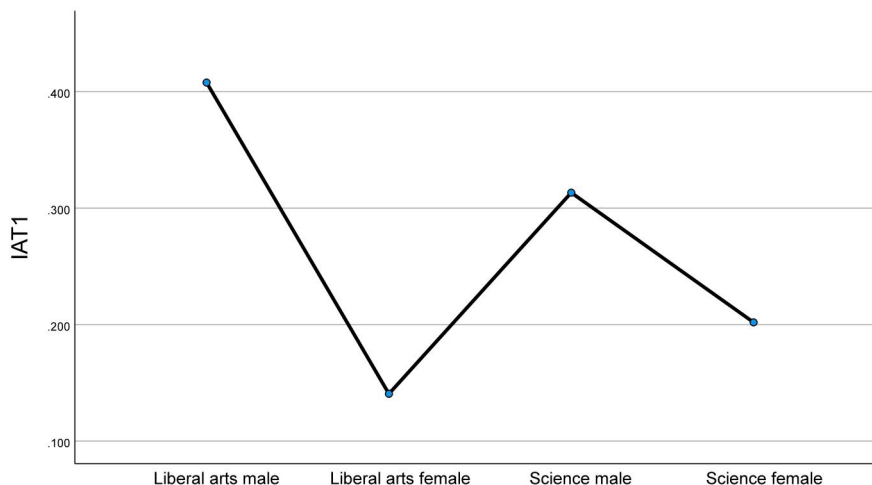

Figure13 Average score of IAT1 of four groups college students

One-way ANOVA and multiple comparisons were conducted on their scores, and the results are presented in Table38 and Table39, respectively.

Table38 One-way ANOVA of IAT1

	M±SD		SS	df	MS	F	P	η^2
Liberal arts male	.408±.497	Between Groups	1.537	3	.512	3.220*	.024	.058
Liberal arts female	.141±.564	Within Groups	25.137	158	.159			
Science male	.313±.236	Total	26.674	161				
Science female	.212±.234							

Note: *=P<.05.

Table38 shows significant differences in IAT1 D value among the four groups of college students (F=3.220, P=.024, η^2 =.058). To further compare these differences, multiple comparisons were conducted, and the results are presented in Table39.

Table39 Multiple comparisons of four groups college students' IAT1

		Mean Difference	SE	P
	Liberal arts female	.267*	.094	.005
Liberal arts male	Science male	.095	.104	.366
	Science female	.206*	.087	.019

	Liberal arts male	-.267*	.094	.005
Liberal arts female	Science male	-.173	.099	.083
	Science female	-.061	.080	.446

	Liberal arts male	-.095	.104	.366
Science male	Liberal arts female	.173	.099	.083
	Science female	.111	.092	.228

	Liberal arts male	-.206*	.087	.019
Science female	Liberal arts female	.061	.080	.446
	Science male	-.111	.092	.228

Note: *The mean difference is significant at the 0.05 level.

The results of the multiple comparisons reveal that liberal arts male has significantly higher IAT1 D value compared to liberal arts female as well as science female. A higher D value on IAT1 indicates a stronger association between male and masculine traits, female and feminine traits. Based on the ranking of IAT1 D value, the order from high to low is: liberal arts male>science male>science female>liberal arts female. This implies that trait gender stereotypes are most strongly implicitly endorsed for male individuals in the liberal arts, while female individuals in the liberal arts are the least likely to endorse them implicitly.

5.7.3. Implicit subject gender stereotypes of the CSGS college students

5.7.3.1. Comparison of implicit subject stereotypes between the CSGS and the SGS college students

To understand the implicit subject gender stereotypes of the CSGS college students, the D

value of implicit subject gender stereotype of the CSGS college students and that of the SGS college students are compared. At the same time, an attitude IAT's zero point means absence-of-preference. If the $D < 0$, it means the latency of incompatible combined tasks (Male+Liberal arts and Female+ Science) are shorter than that of compatible combined tasks (Male+Science and Female+Liberal arts). If $D > 0$, it means the latency of incompatible combined tasks are longer than that of compatible combined tasks. So, it can also use 0 as the test value to conduct a one-sample t-test on the D values of IAT2 of the CSGS and the SGS college students. The results are shown in Table40.

Table40 Comparison of implicit subject stereotypes between the CSGS and the SGS college students ($M \pm SD$)

	Implicit subject gender Stereotypes	n	t (median =0)	Cohen d
CSGS college Students	.18 ± .32	93	5.547***	.575
SGS college Students	.21 ± .38	68	4.570***	.554
t	-.534			
P	.297			

Note: ***= $P < .001$.

Table40 shows that, there is no significant difference in the D values of the CSGS college students and the SGS college students on implicit subject gender stereotypes ($t = -.534$, $P = .297$), indicating that the CSGS college students have no weaker implicit subject gender stereotypes than the SGS college students. Thus, H7 has not been confirmed. At the same time, the D values of both are higher than 0, which are statistically significant ($t = 5.547$; $t = 4.570$), and both the effect size have also reached a not low level (Cohen $d = .575$; Cohen $d = .554$), indicating that both are all inclined to the combination of male with science, and female with liberal arts.

5.7.3.2. Influence of various variables on implicit subject gender stereotypes

To further investigate the influence of sex, major, residence, and their interaction on implicit subject gender stereotypes, a multi-way ANOVA was conducted.

Table41 Multi-way ANOVA of IAT2

	SS	df	MS	F	P	$\eta^2_{partial}$
Sex	.025	1	.025	.205	.651	.001
Major	.085	1	.085	.704	.403	.005
Residence	.001	1	.001	.007	.935	.000
Sex*Major	.029	1	.029	.244	.622	.002
Sex*Residence	.305	1	.305	2.525	.114	.016
Major*Residence	.007	1	.007	.058	.809	.000
Sex*Major*Residence	.047	1	.047	.387	.535	.003

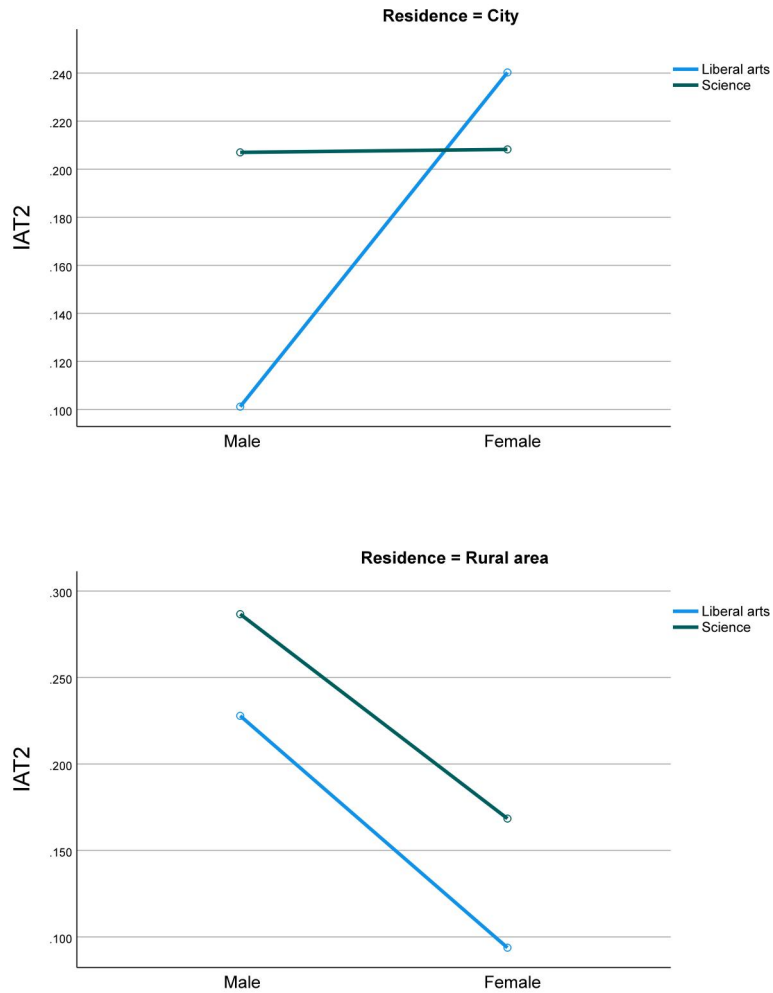

Figure14 Effects of sex, major, residence and their interaction on IAT2

Table41 and Figure14 indicate that the main effects and interactions of the three variables - sex, major, and residence - are not significant, suggesting that these variables do not have a significant impact on IAT2. Regardless of gender, major, or residence, participants demonstrated consistency in their implicit subject gender stereotypes.

5.7.3.3. Further exploration of the influence of sex and major on implicit subject gender stereotypes

To reconfirm that sex and major have no impact on implicit subject gender stereotypes, the combination of major and sex variables was divided into four groups: liberal arts male, liberal arts female, science male, and science female. The average score of the four groups of college students on the IAT2 is shown in Figure15. One-way ANOVA was conducted on their scores, and the results are presented in Table42.

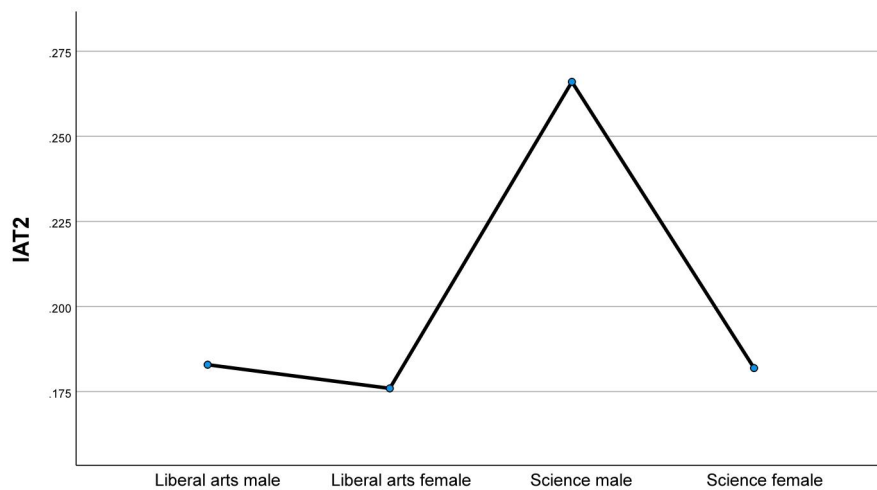

Figure15 Average score of IAT2 of four groups college students

Table42 One-way ANOVA of IAT2

	M±SD		SS	df	MS	F	P	η^2
Liberal arts male	.183±.465	Between Groups	.166	3	.055	.460	.710	.009
Liberal arts female	.176±.467							
Science male	.266±.187	Within Groups	18.884	157	.120			
Science female	.182±.213							
		Total	19.051	160				

The results show there in no significant differences in IAT2 D value among the four groups of college students ($F=.460$, $P=.710$, $\eta^2=.009$). Once again, participants from different sex and major have consistent implicit subject gender stereotypes.

5.7.4. Implicit math/language gender stereotypes of the CSGS college students

5.7.4.1. Comparison of implicit math/language stereotypes between the CSGS and the SGS college students

To understand the implicit math/language gender stereotypes of the CSGS college students, the D value of implicit math/language gender stereotype of the CSGS college students and that of the SGS college students are compared. At the same time, an attitude IAT's zero point means absence-of-preference. If the $D < 0$, it means the latency of incompatible combined tasks (Male + language and Female + Math) are shorter than that of compatible combined tasks (Male + Math and Female + language). If $D > 0$, it means the latency of incompatible combined tasks are longer than that of compatible combined tasks. So, it can also use 0 as the test value to conduct a one-sample t-test on the D values of IAT3 of the CSGS and the SGS college students. The results are shown in Table43.

Table43 Comparison of implicit math/language stereotypes between the CSGS and the SGS college students (M±SD)

	Implicit math/language gender Stereotypes	n	t (median =33)	Cohen d
CSGS college Students	.23 ± .42	94	5.161***	.538
SGS college Students	.17 ± .36	69	3.948***	.475
t	.864			
P	.194			

Note: ***= $P < .001$.

Table43 shows that, there is no significant difference in the D values of the CSGS college students and the SGS college students on implicit math/language gender stereotypes ($t=.864$,

P=.194), indicating that the CSGS college students have no weaker implicit math/language gender stereotypes than the SGS college students. Thus, H8 has not been confirmed. At the same time, the D values of both are higher than 0, which are statistically significant ($t=5.161$; $t=3.948$), and both the effect size have also reached a not low level (Cohen $d=.538$; Cohen $d=.475$), indicating that both are all inclined to the combination of male with math, and female with language.

5.7.4.2. Influence of various variables on implicit math/language gender stereotypes

To further investigate the influence of sex, major, residence, and their interaction on implicit math/language gender stereotypes, a multi-way ANOVA was conducted. Table44 and Figure16 indicate that the main effects and interactions of the three variables - sex, major, and residence - are not significant, suggesting that these variables do not have a significant impact on IAT2. Regardless of gender, major, or residence, participants demonstrated consistency in their implicit math/language gender stereotypes.

Table44 Multi-way ANOVA of IAT3

	SS	df	MS	F	P	$\eta^2_{partial}$
Sex	.061	1	.061	.388	.535	.003
Major	.002	1	.002	.011	.917	.000
Residence	.018	1	.018	.116	.733	.001
Sex*Major	.019	1	.019	.118	.731	.001
Sex*Residence	.028	1	.028	.179	.673	.001
Major*Residence	.001	1	.001	.003	.954	.000
Sex*Major*Residence	.872	1	.872	5.530	.020*	.035

Note: *=P<.05.

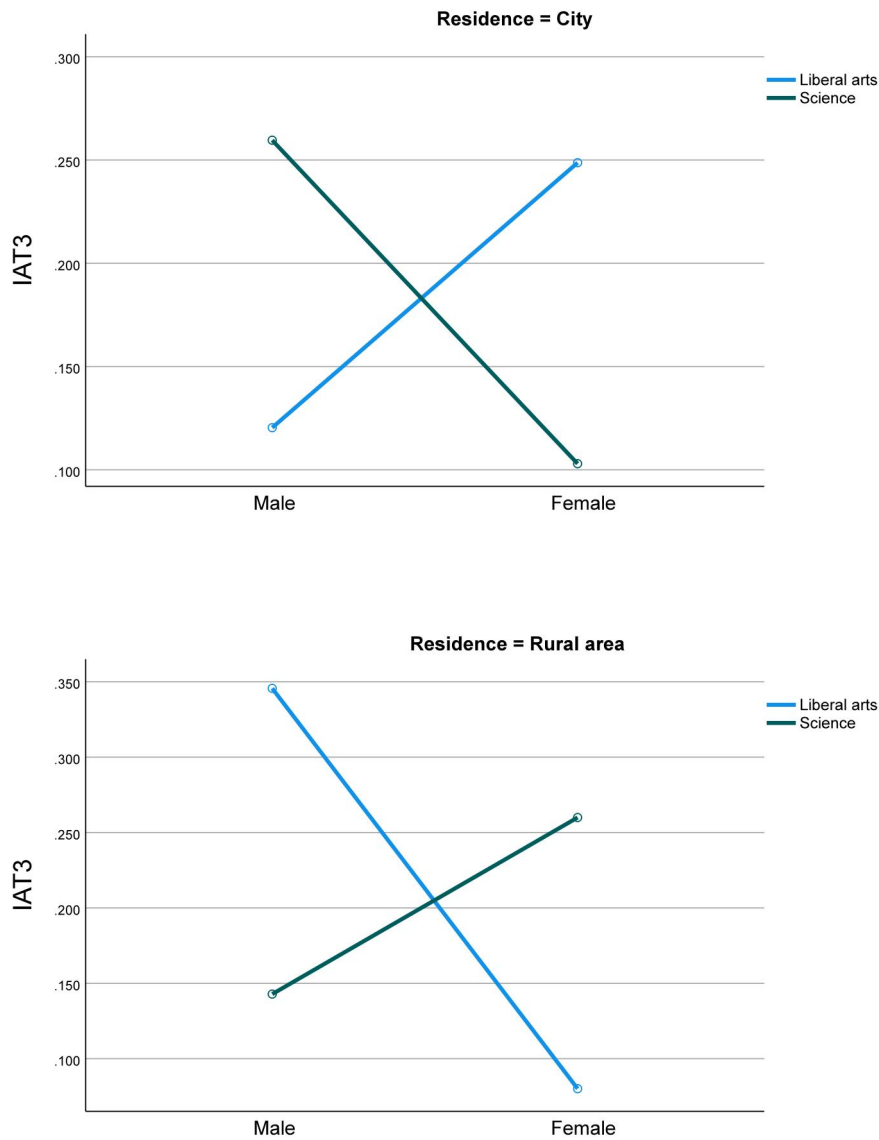

Figure16 Effects of sex, major, residence and their interaction on IAT3

5.7.4.3. Further exploration of the influence of sex and major on implicit math/language gender stereotypes

To reconfirm that sex and major have no impact on implicit math/language gender stereotypes, the combination of major and sex variables was divided into four groups: liberal arts male, liberal arts female, science male, and science female. The average score of the four groups of college students on the IAT3 is shown in Figure17. One-way ANOVA and multiple comparisons were conducted on their scores, and the results are presented in Table45.

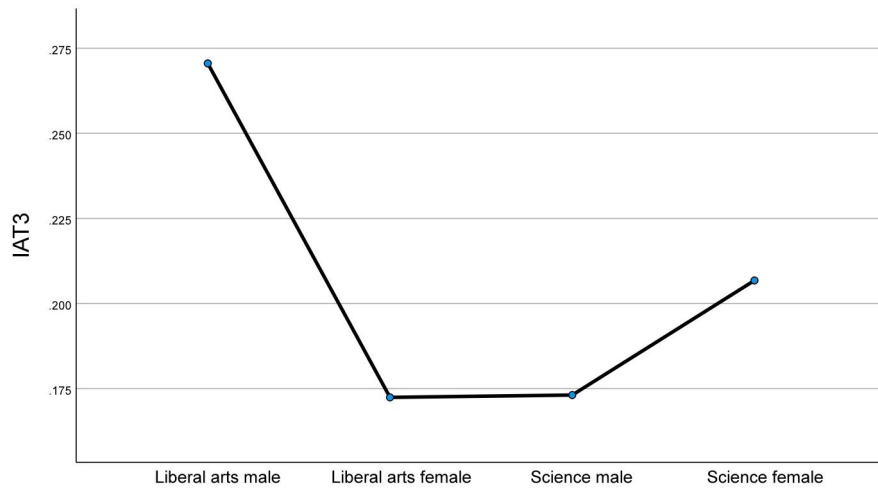

Figure17 Average score of IAT3 of four groups college students

Table45 One-way ANOVA of IAT3

	M±SD		SS	df	MS	F	P	η^2
Liberal arts male	.271±.659	Between Groups	.201	3	.067	.418	.741	.008
Liberal arts female	.172±.427	Within Groups	25.175	157	.160			
Science male	.173±.241	Total	25.376	160				
Science female	.207±.244							

The results show there in no significant differences in IAT3 D value among the four groups of college students ($F=.418$, $P=.741$, $\eta^2=.008$). Once again, participants from different sex and major have consistent implicit math/language gender stereotypes.

5.8. Discussion

5.8.1. Implicit trait gender stereotypes of the CSGS college students

Previous research on implicit trait gender stereotypes has shown that college students tend to associate men with masculine traits such as independence, bravery, and rationality, while women are associated with feminine traits such as submissiveness, dependence, and kindness (Cai et al., 2001; Jia, 2013; Liu, 2007; Zuo & Liu, 2006). This study confirms these findings for both CSGS and SGS students, despite China's advocacy for gender equality and increasingly diverse social culture. As a group with rich knowledge and active thinking,

college students should be open-minded, yet they still hold implicit trait gender stereotypes. Even among CSGS students, who have chosen careers that oppose traditional gender stereotypes, interview data suggests that trait gender stereotypes remain stable. While they denied that men are more suitable for science and engineering and women for liberal arts, they still believe that men are more rational and independent than women, and women are more tender and emotional than men. This highlights the stability of trait gender stereotypes, which has been observed in previous studies (Bergen & Williams, 1991; Haines et al., 2016; Lueptow et al., 1995).

The study also investigated whether CSGS students' trait gender stereotypes are weaker than those of SGS students. However, statistical analysis did not support this hypothesis, and H6 was not confirmed.

The study found no significant difference in implicit trait gender stereotypes between CSGS and SGS college students, indicating that being a CSGS college student is not a variable that affects implicit trait gender stereotypes. However, the study did reveal the significant role of gender in implicit trait gender stereotypes, with female college students exhibiting lower levels of implicit approval of trait gender stereotypes compared to male college students. Therefore, contrary to the research hypothesis, the current study finds that the participant's performance on implicit trait gender stereotypes is determined not by whether they are CSGS college students, but rather by their sex. Many studies have shown that there is no sex difference in implicit trait gender stereotypes, which means that both men and women share same trait gender stereotypes (Cai et al., 2001; Xu, 2003; Zuo & Liu, 2006). However, some studies have also shown that there are differences in implicit trait gender stereotypes between men and women. This study found that men implicitly recognize trait gender stereotypes more than women, consistent with the findings of Jia (2013). Thus, further research is necessary to clarify the relationship between gender and implicit trait gender stereotypes.

5.8.2. Implicit subject gender stereotypes of the CSGS college students

During interviews, CSGS college students expressed that they did not recognize subject gender stereotypes. Some studies also have found that the subject gender stereotype has weakened over the past 10 years, based on explicit and implicit gender stereotype test data (Charlesworth & Banaji, 2022). However, the current study reveals that both CSGS and SGS

college students have implicit subject gender stereotypes, whereby science and engineering are implicitly considered male subjects, and liberal arts as female subjects. This finding is consistent with the results of previous studies (He & Liu, 2007; Li, 2016; Li & Jia, 2009). It is worth noting that although the participants denied the subject gender stereotype in the explicit gender stereotype test, they demonstrated the subject gender stereotype in the IAT2, which can be regarded as an experimental dissociation.

This study aimed to investigate whether there was a difference in implicit subject gender stereotypes between CSGS college students and SGS college students, as well as the role of sex in it. However, the statistical analysis did not support the hypothesis that CSGS college students had weaker implicit subject gender stereotypes than SGS college students. H7 has not been confirmed. Moreover, there was no difference in implicit subject gender stereotypes between men and women, indicating that they shared the same implicit subject gender stereotypes. However, there was a significant difference in explicit subject gender stereotypes between men and women, with women being more likely to reject subject gender stereotypes than men. This highlights the experimental dissociation between explicit and implicit subject gender stereotypes, where men and women both implicitly share subject gender stereotypes, but differ in their explicit rejection of them.

5.8.3. Implicit math/language gender stereotypes of the CSGS college students

Both the CSGS and SGS college students in the explicit math gender stereotype and language gender stereotype tests expressed disapproval of math/language gender stereotypes. However, in IAT3, they both displayed implicit math/language gender stereotypes, which is consistent with previous studies (Morrissey et al., 2019; Nosek et al., 2002). This finding suggests another experimental dissociation between explicit and implicit gender stereotypes. The relationship between explicit and implicit gender stereotypes will be further discussed later.

This study is also concerned about whether CSGS college students' implicit math/language gender stereotype will be weaker than that of the SGS college students. Unfortunately, statistical analysis shows that there is no such relationship between the two. H8 has not been confirmed. At the same time, the role of sex is not reflected in implicit math/language gender stereotype, which means that men and women share the same implicit math/language gender stereotype. However, there is a significant sex difference in explicit math/language gender

stereotypes, with women explicitly rejecting math/language gender stereotypes more than men. This again indicates an experimental dissociation of explicit and implicit math/language gender stereotypes, in which men and women implicitly share math/language gender stereotypes, but differ in their explicit rejection of them.

5.9. Conclusion

- a) Compared with the SGS college students, the implicit trait gender stereotypes of the CSGS college students are not weaker. H6 has not been confirmed.
- b) Compared with the SGS college students, the implicit subject gender stereotypes of the CSGS college students are not weaker. H7 has not been confirmed.
- c) Compared with the SGS college students, the implicit math/language gender stereotypes of the CSGS college students are not weaker. H8 has not been confirmed.
- d) All college students implicitly associate male with masculinity, and female with femininity.
- e) There are gender differences in implicit trait gender stereotypes, indicating female college students identify with trait gender stereotypes to a lower extent than male college students.
- f) Trait gender stereotypes are most strongly endorsed for male individuals in the liberal arts, while female individuals in the liberal arts are the least likely to endorse them.
- g) All college students implicitly associate male with science, and female with liberal arts, and this association does not differ by gender, major, or residence.
- h) All college students implicitly associate male with math, and female with language, and this association does not differ by gender, major, or residence.

6. The Relationship between Implicit and Explicit Gender Stereotypes of the CSGS College Students

6.1. Research purpose

Analyzing the relationship between implicit gender stereotypes and explicit gender stereotypes of the CSGS college students by using data statistical analysis method.

6.2. Research hypothesis

This study will verify the 2 of the 18 research hypotheses, which are:

H9: There is a weak correlation between the explicit and the implicit subject gender stereotypes of the CSGS college students, and even experimental dissociation may occur;

H10: There is a weak correlation between the explicit and the implicit math/language gender stereotypes of the CSGS college students, and even experimental dissociation may occur.

6.3. Participants

368 participants completed the explicit scale, of which 163 participants completed IAT. The purpose of this study is to explore the relationship between explicit and implicit gender stereotypes of CSGS college students, so 163 participants who completed both implicit and explicit tests are our subjects, seeing Table32. It should also be noted that when processing IAT data, some participant data will be deleted(Greenwald et al., 2022; Greenwald et al., 2003). Therefore, it is normal that the number of participants of each IAT will be different.

6.4. Instruments

The instruments needed in this study have been introduced in the previous article, including the following:

- a) Explicit Subject Gender Stereotypes Scale (ESGS)
- b) Explicit Math Gender Stereotypes Scale (EMGS)
- c) Explicit Language Gender Stereotypes Scale (ELGS)
- d) IAT of implicit subject gender stereotypes (IAT2)
- e) IAT of implicit math/language gender stereotypes (IAT3)

6.5. Research procedure

The research procedure is shown in 4.5 and 5.5. It should be noted that there is a gap of one week between the IAT and the explicit scale test.

6.6. Data processing

The data collected in this study were statistically analyzed with SPSS28.0 and Amos21.0 software. According to the research hypothesis and data conditions, this study mainly carries out the correlation analysis, exploratory factor analysis(EFA) and confirmatory factor analysis(CFA).

6.7. Results

6.7.1. Correlation analysis of explicit and implicit gender stereotypes

In order to explore the relationship between explicit and implicit gender stereotypes of the CSGS college students, it focuses on explicit and implicit subject gender stereotype and math/language gender stereotype, and carry out correlation analysis. The results are shown in the Table46.

Table46 Correlation matrix of ESMGS, ELFGS, EMGS, ELGS, IAT2 and IAT3(CSGS college students)

	ESMGS	ELFGS	EMGS	ELGS	IAT2	IAT3
ESMGS	1.000	.572***	.217	-.052	-.003	-.042
ELFGS		1.000	.214	.295**	-.060	-.070
EMGS			1.000	.656***	-.194	-.058
ELGS				1.000	-.253**	-.169
IAT2					1.000	.661***
IAT3						1.000

Note: **=P<.01; ***=P<.001.

ESMGS=Explicit Science Male Gender Stereotypes; ELFGS=Explicit Liberal Arts Female Gender Stereotypes; EMGS=Explicit Math Gender Stereotypes; ELGS=Explicit Language Gender Stereotypes.

Table46 shows that for the CSGS college students, the positive correlation between ESMGS and ELFGS($r=.572$), the positive correlation between EMGS and ELGS($r=.656$), the positive correlation between ITA2 and IAT3($r=.661$), the positive correlation between ELFGS and

ELGS($r=.295$), and the negative correlation between ELGS and IAT2($r=-.253$) have all reached a statistically significant level. However, the correlation between the other variables did not reach a statistically significant level. In particular, it should be noted that the correlation between ESMGS and ELFGS($r=.572$), EMGS and ELGS($r=.656$), and IAT2 and IAT3($r=.661$) has reached or closed to strong correlation. For the CSGS college students, it means that: a) The explicit connection between science and male is highly positively correlated with the explicit connection between language and female; b) The explicit math gender stereotypes are highly positively correlated with the explicit language gender stereotypes; c) Implicit subject gender stereotypes are highly correlated with implicit math/language gender stereotypes. In general, high correlation tends to occur either in direct measurement or indirect measurement, but not between direct and indirect measurement. This pattern is also observed in both SGS college students and all college students, as indicated in the Table47 and Table48. Thus, H9 and H10 has been confirmed.

Table47 Correlation matrix of ESMGS, ELFGS, EMGS, ELGS, IAT2 and IAT3 (SGS college students)

	ESMGS	ELFGS	EMGS	ELGS	IAT2	IAT3
ESMGS	1.000	.561***	.402***	.251*	.213*	-.024
ELFGS		1.000	.075	.117	.013	-.147
EMGS			1.000	.684***	.094	.022
ELGS				1.000	.210*	.109
IAT2					1.000	.760***
IAT3						1.000

Note: *= $P<.05$; ***= $P<.001$.

ESMGS=Explicit Science Male Gender Stereotypes; ELFGS=Explicit Liberal Arts Female Gender Stereotypes; EMGS=Explicit Math Gender Stereotypes; ELGS=Explicit Language Gender Stereotypes.

Table48 Correlation matrix of ESMGS, ELFGS, EMGS, ELGS, IAT1 and IAT2(all college students)

	ESMGS	ELFGS	EMGS	ELGS	IAT2	IAT3
ESMGS	1.000	.577***	.275***	.107	.108	-.045
ELFGS		1.000	.132*	.239***	-.020	-.108
EMGS			1.000	.675***	-.039	-.032
ELGS				1.000	-.026	-.068
IAT2					1.000	.690***
IAT3						1.000

Note: *=P<.05; ***=P<.001.

ESMGS=Explicit Science Male Gender Stereotypes; ELFGS=Explicit Liberal Arts Female Gender Stereotypes; EMGS=Explicit Math Gender Stereotypes; ELGS=Explicit Language Gender Stereotypes.

6.7.2. Exploratory factor analysis of explicit and implicit gender stereotypes

In order to further explore the relationship between explicit gender stereotype and implicit gender stereotype of the CSGS college students, especially to investigate the possibility of implicit gender stereotypes acting as an independent factor, exploratory factor analysis was further conducted on the variables for previous correlation analysis.

Table49 The results of KMO and Bartlett's Test (CSGS college students)

KMO and Bartlett's Test		
Kaiser-Meyer-Olkin Measure of Sampling Adequacy		.437
	Approx. Chi-Square	165.849
Bartlett's Test of Sphericity	df	15
	Sig.	<.001

Table49 shows that, KMO=.437 which is not very ideal, but Bartlett's test of sphericity has reached a significant level(P<.001). In addition, the purpose of this study is not to really reduce dimensions, but to determine whether implicit and explicit gender stereotype are two independent factors. Therefore, exploratory factor analysis continues.

This exploratory factor analysis uses principal component analysis to extract common factors, and uses the varimax method in rotation. According to the scree plot, factor eigenvalue and total variance explained ratio, 3 factors are extracted, and the cumulative variance explained rate of these 3 factors is 82.255%. After the varimax rotation, the 6 components are divided into 3 higher-order factors, and each components have a higher factor loading (.862~.919) on its higher-order factor, and there are no excessive cross factor loadings, and the factor structure is clear, seeing Table50 and Table51.

Table50 The total variance explained (CSGS college students)

Total Variance Explained									
Component	Initial Eigenvalues			Extraction Sums of Squared			Rotation Sums of Squared		
				Loadings			Loadings		
	Total	% of Variance	Cumulative %	Total	% of Variance	Cumulative %	Total	% of Variance	Cumulative %
1	2.126	35.432	35.432	2.126	35.432	35.432	1.697	28.281	28.281
2	1.524	25.397	60.829	1.524	25.397	60.829	1.667	27.785	56.065
3	1.286	21.426	82.255	1.286	21.426	82.255	1.571	26.189	82.255
4	.531	8.847	91.101						
5	.328	5.474	96.576						
6	.205	3.424	100						

Table51 The rotated component matrix (CSGS college students)

Rotated Component Matrix			
	Component		
	1	2	3
ESMGS	-.062	-.005	.904
ELFGS	.212	-.037	.862
EMGS	.892	-.034	.080
ELGS	.907	-.151	.054
IAT2	-.174	.893	.006
IAT3	-.011	.919	-.047

Note: ESMGS=Explicit Science Male Gender Stereotypes; ELFGS=Explicit Liberal Arts Female Gender Stereotypes; EMGS=Explicit Math Gender Stereotypes; ELGS=Explicit Language Gender Stereotypes.

It can be seen that ESMGS and ELFGS subordinate factor 3, EMGS and ELGS subordinate factor 1, IAT2 and IAT3 subordinate factor 2. Both ESMGS and ELFGS measure explicit subject gender stereotypes, while EMGS and ELGS measure explicit math/language gender stereotypes. There is a high correlation between them, and they belong to different factors, which is not surprising. However, IAT2 and IAT3 measure the implicit subject gender stereotypes and implicit math/language gender stereotypes respectively. The high correlation between them indicates that they constitute an independent factor and are connected and independent with other explicit measurements.

It should be noted that the same exploratory factor analysis is carried out on the data of the SGS college students and all college students, the result is also that IAT2 and IAT3 constitute an independent factor compared with other explicit measurement. Thus, H9 and H10 has been confirmed again.

6.7.3. Confirmatory factor analysis of explicit and implicit gender stereotypes

In order to further verify the relationship between explicit and implicit gender stereotypes of CSGS college students, a confirmatory factor analysis was conducted. Three models have been

built respectively. Model 1 is a single-factor model, Model 2 is a two-factor model of explicit and implicit stereotypes, and Model 3 is a three-factor model based on the previous exploratory factor analysis results. The results are shown in Figure18, Figure19 and Figure20.

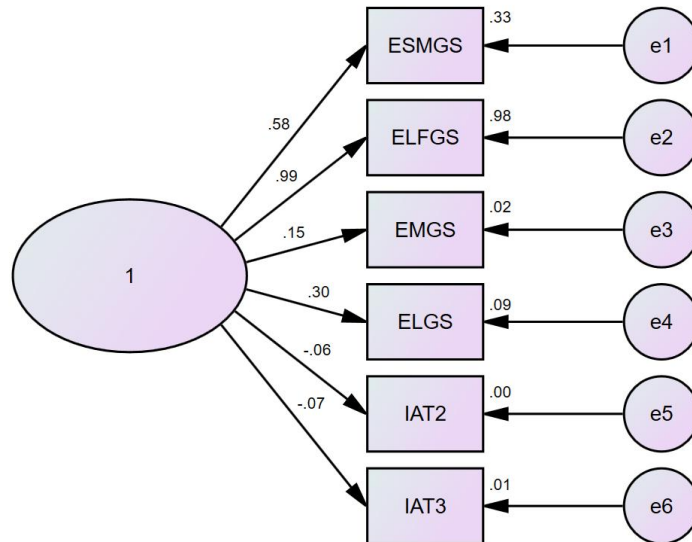

Figure18 Single-factor model (CSGS college students)

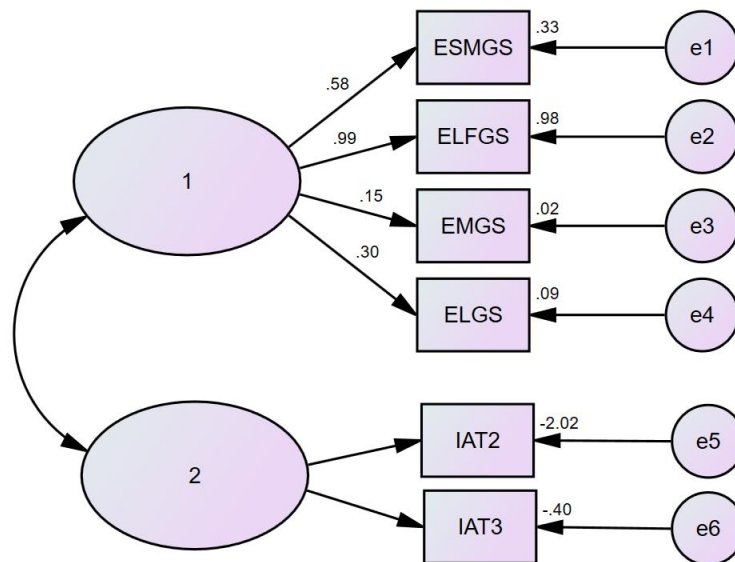

Figure19 Two-factor model (CSGS college students)

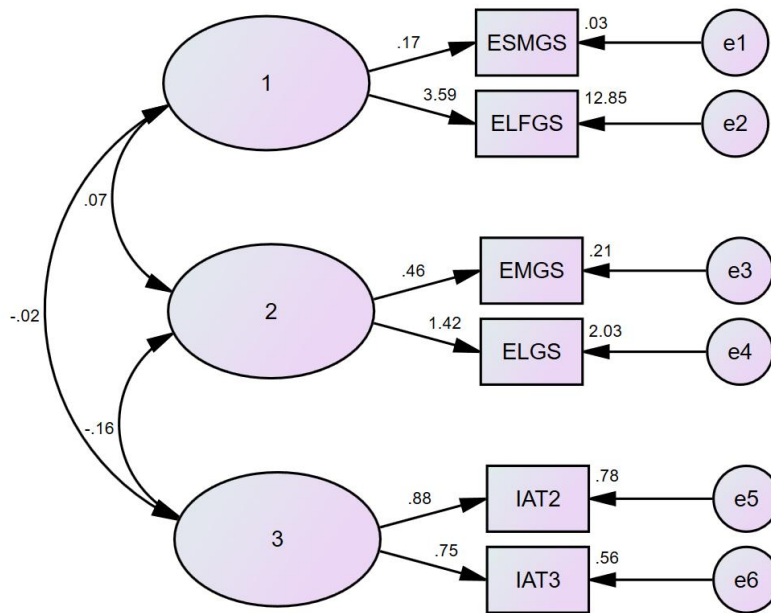

Figure20 Three-factor model (CSGS college students)

The fitting indicators of the three models are shown in Table52. It can be seen that model 1, which attributes explicit and implicit gender stereotypes to one factor, has the worst fitting, and model 2, which attributes explicit and implicit gender stereotypes to two factors, has better fitting than model 1. The best fitting is model 3 which ESMGS and ELFGS are classified as one factor, and EMGS and ELGS are classified as one factor, IAT2 and IAT3 are classified as one factor. Generally speaking, implicit IAT2 and IAT3 can constitute independent factors compared with other explicit items. Thus, H9 and H10 has been confirmed again.

Table52 Fitting index of three models (CSGS college students)

	χ^2/df	RMSER	GFI	NFI	RFI	IFI	TLI	CFI
Single-factor model	12.477	.357	.738	.271	-.093	.288	-.102	.265
Two-factor model	8.157	.282	.830	.571	.285	.603	.313	.588
Three-factor model	1.186	.046	.971	.952	.896	.992	.982	.992

6.8. Discussion

6.8.1. The relationship between implicit and explicit gender stereotypes

There is no doubt that gender stereotypes belong to the category of social cognition, and the relationship between implicit social cognition and explicit social cognition has always been the focus of controversy in academic circles. One of the sources of these disputes is that people's definitions of explicit and implicit are ambiguous. According to Greenwald et al. (2022), there are two kinds of understanding of explicit and implicit. One is to regard them as attributes of psychological measurement, direct measurement is explicit, and indirect measurement is implicit; The other regards them as attributes of psychological process or psychological representation. They can be regarded as operating in an automatic or unconscious way or in a controlled or conscious way. The automatic or unconscious way is implicit, and the controlled or conscious way is explicit. The two kinds of understanding have their own supporters. As early as the 1990s, Jacoby (1991) proposed that it was unreasonable to take indirect measurement as a pure indicator of unconscious process or direct measurement as a pure indicator of conscious process. Subsequently, some researchers clearly suggested that explicit and implicit can only be understood as the attributes of psychological measurement, rather than the synonyms of consciousness and unconsciousness (Fazio & Olson, 2003; Greenwald & Banaji, 2017; Greenwald et al., 2022; Greenwald et al., 1998); But other researcher clearly indicated that implicit is an automatic synonym, in other words, implicit means automatic mental process(De Houwer et al., 2009). However, since researchers have no agreement on the extent to which direct measurement is a controlled mental operation and indirect measurement is an automatic mental operation, it is obviously a more cautious attitude to define explicit and implicit as attributes of psychological measurement. Thus, Greenwald and Lai (2020) proposed to define explicit as direct measurement and implicit as indirect measurement, which is an operational definition, and not as controversial as automatic and unconscious terms. It is a theory-uncommitted definition, allowing research to continue without debate on the difference of implicit and explicit. Even so, if the essential difference between explicit direct measurement and implicit indirect measurement is not the difference between consciousness and unconsciousness, automation and control, then whether there is any difference between them and what is the difference is still a question that needs to be answered by researchers, which is directly related to the question of whether indirect measurement is necessary. Obviously, the logic is as follows: if there is no difference between

direct measurement and indirect measurement, and indirect measurement is not an unconscious mental process and does not measure unconscious cognition, then indirect measurement is not necessary. After all, indirect measurement is not more convenient and labor-saving than direct measurement.

Even though there is no agreement on the definition of explicit and implicit, it does not prevent researchers from turning to the study of their relationship. As mentioned earlier, this is an extremely important issue, which is related to the existence of indirect measurement. According to Nosek (2007), there are three possible relationships between direct measurement and indirect measurement: a) They measure different constructs, and the two are completely different, so the difference in measurement results is not surprising; b) They measure the same construct, so the measurement results should be consistent. If there is inconsistency, it is due to other factors besides cognition; c) They measure related but different constructs. What kind of relationship will the actual research evidence support? Nosek (2005) and Nosek and Smyth (2007) supported the third possible relationship based on the evidence of the relationship between self-reporting and IAT on a large number of different domains, including the use of structural equation model technology to construct different models, and the dual-attitude model is better than the single-attitude model and the direct measurement and indirect measurement are moderately correlated. Hofmann et al. (2005) conducted a meta-analysis of 81 studies and found that the correlation between direct measurement and IAT was $-.25 \sim .60$, and the overall IAT-explicit relationship can be diagnosed as heterogeneity. Other researchers believed that people can hold both implicit and explicit attitudes at the same time, so they put forward a dual attitudes model, which is to recognize the independent status of implicit cognition (Wilson et al., 2000).

This study also supports the relative but different relationship between explicit measurement and implicit measurement. Through correlation analysis, it can be seen that the correlation between explicit and implicit subject gender stereotype, and the correlation between explicit and implicit math/language gender stereotype of the CSGS college students are weak ($r = -.003 \sim r = -.253$), therefore, H9 and H10 are confirmed. At the same time, this phenomenon is also true in the data of the SGS college students and all college students. On this basis, this study uses exploratory factor analysis to continue to explore the relationship between explicit

gender stereotypes and implicit gender stereotypes of the CSGS college students. It is found that three common factors can be proposed among ESMGS, ELFGS, EMGS, ELGS, IAT2 and IAT3, while IAT2 and IAT3 exist as an independent factor, which shows that implicit gender stereotypes and explicit gender stereotypes are both related and independent. In the results of confirmatory factor analysis, all models that take IAT2 and IAT3 as independent factors are superior to model 1, indicating that explicit gender stereotypes and implicit gender stereotypes cannot be attributed to the same factor, further proving that explicit gender stereotypes and implicit gender stereotypes are independent of each other. The above discussion on the relationship between explicit and implicit cognition does not mean that a final conclusion has been formed. What is the relationship between explicit and conscious, implicit and unconscious needs further exploration. In fact, if implicit cognition only means a kind of construct that is related to explicit but different from it, the value and significance of indirect measurement will be questioned. This doubt can only be reduced by the predictive power of implicit cognition on behavior. This is also the reason why the current studies will focus on the validity of the prediction of implicit gender stereotypes on achievement and attitude.

In addition, it should be noted that in this study, the explicit and implicit gender stereotype of the CSGS college students is mostly negatively correlated ($r = -.003 \sim r = -.253$), which means that the higher the score of explicit gender stereotype, the lower the score of implicit gender stereotype. This is an interesting phenomenon that may require further research.

6.8.2. The experimental dissociation of explicit and implicit gender stereotypes

Although the research in the previous section has shown the exist of experimental dissociation, it has not been discussed. Because experimental dissociation is closely related to the relationship of explicit and implicit, it is put into this section for discussion.

In previous studies, there are two situations in the relationship between explicit and implicit stereotypes of the same group: one is that implicit and explicit stereotypes are consistent, and the other is that implicit and explicit stereotypes are not consistent, resulting in experimental dissociation. Experimental dissociation is considered as a psychology research technology: in psychological experiments, control and compare the effects of independent variables in two different test tasks. If the influence of independent variables on the two test tasks is different in size or direction, it can be said that there is experimental dissociation ("Experimental

dissociation," 2003). The logical assumption of experimental dissociation is that the information needed to complete different tasks is different, so the mental processing involved is also different, therefore, different tests can show different mental processes. If the same independent variable makes different tests have consistent or inconsistent results, it can be inferred that there are similarities or differences in the internal mental process of completing these tests(Deng, 2016). In this study, both the CSGS and the SGS college students showed gender stereotypes lower than the median in the explicit gender stereotype test. However, in IAT, they showed gender stereotypes higher than the median. This means that in the test of explicit gender stereotypes, they tend to deny gender stereotypes, while in IAT, they tend to affirm gender stereotypes. Thus, experimental dissociation appeared. Similar findings have been made in previous studies(Cai et al., 2001; Xu, 2003; Zhang, 2021). According to the logic of experimental dissociation, this means that there are two different mental processes to complete the explicit gender stereotype test and IAT. At the same time, it also proves the value of indirect measurement which is indeed possible to measure a completely different mental process. However, not all direct and indirect measurements will have experimental dissociation. Nosek (2007) has done research on the relationship between direct measurement and indirect measurement in multiple domains and found that there was a positive correlation between them, which means that the explicit preference for A rather than B also showed the same performance on implicit tests. There was no experimental dissociation.

Why are there conflicting results? One possible explanation is that for non-social sensitive fields, the results of direct measurement and indirect measurement will be highly correlated, and preferences will be consistent. However, for socially sensitive fields, such as gender, race, religion, etc., the results of direct measurement and indirect measurement may be weakly correlated or even zero correlated, and preferences will be inconsistent, and experimental dissociation will occur. Indeed, in today's China, if a person openly expresses his or her gender stereotypes about men and women, it may make people around frown. College students' expression of support for gender stereotypes will also be considered as not enlightened and foolish. Therefore, in public, support for gender stereotypes is rarely heard, and gender equality has become political correctness. In this case, it is not surprising that college students do not agree with gender stereotypes in direct measurement. However, in the indirect

measurement, experimental dissociation appears, which seems to mean that gender stereotypes still leave indelible traces in the human mind, although there are still many disputes about the relationship between indirect measurement and direct measurement.

6.9. Conclusion

- a) There is a weak correlation between the explicit subject gender stereotypes and the implicit subject gender stereotypes of the CSGS college students, and experimental dissociation occur. H9 has been confirmed.
- b) There is a weak correlation between the explicit math/language gender stereotypes and the implicit math/language gender stereotypes of the CSGS college students, and experimental dissociation occur. H10 has been confirmed.

7. Math/Language Attitudes of the CSGS College Students and Their Relationship with Gender Stereotypes

7.1. Research purpose

This study aims to investigate the explicit and implicit math/language attitudes of CSGS college students and compare them with SGS college students. Additionally, the study will analyze the relationship between gender stereotypes and math/language attitudes, and explore the predictive ability of both explicit and implicit gender stereotypes on math/language attitudes.

7.2. Research hypothesis

This study will verify the 4 of the 18 research hypotheses, which are:

H11: There are differences in explicit math attitude between the CSGS and the SGS college students;

H12: There are differences in explicit language attitude between the CSGS and the SGS college students;

H13: There are differences in implicit math/language attitudes between the CSGS and the SGS college students;

H14: The explicit gender stereotypes cannot predict explicit and implicit math/language attitudes, while the implicit gender stereotypes can.

7.3. Participants

See 6.3.

7.4. Instruments

The instruments used in this study were introduced in the previous article and include the following:

- a) Explicit Math Attitude Scale (EMA)
- b) Explicit Language Attitude Scale (ELA)
- c) Explicit Subject Gender Stereotypes Scale (ESGS)
- d) Explicit Math Gender Stereotypes Scale (EMGS)
- e) Explicit Language Gender Stereotypes Scale (ELGS)
- f) IAT of implicit trait gender stereotypes (IAT1)
- g) IAT of implicit subject gender stereotypes (IAT2)

- h) IAT of implicit math/language gender stereotypes (IAT3)
- i) IAT of implicit math/language Attitude stereotypes (IAT4)

7.5. Research procedure

The research process is shown in section 6.5. Additionally, the blocks of IAT4 are supplemented in Table53.

Table53 Task of 7 Blocks in the IAT4

Block	No.of trials	Function	Task	Items assigned to left-key response	Items assigned to right-key response
1	20	Practice	Initial target categories classification	Items of math	Items of language
2	20	Practice	Initial attribute categories classification	Items of negative	Items of positive
3	20	Practice	Initial combined task(compatible)	Items of math Items of negative	Items of language Items of positive
4	40	Test	Initial combined task(compatible)	Items of math Items of negative	Items of language Items of positive
5	30	Practice	Reversed attribute categories classification	Items of positive	Items of negative
6	20	Practice	Reversed combined task(incompatible)	Items of math Items of positive	Items of language Items of negative
7	40	Test	Reversed combined task(incompatible)	Items of math Items of positive	Items of language Items of negative

7.6. Data processing

An Excel program is used to calculate the IAT effect value, also known as D value, following the calculation process outlined in Table4. Data analysis is carried out using SPSS28.0. To test the research hypotheses and examine the data, this study primarily employs one-sample t-tests, one-tailed and two-tailed independent-sample t-tests, one-way ANOVA, multi-way ANOVA, correlation analysis, and multiple linear regression.

7.7. Results

7.7.1. Descriptive statistics of explicit and implicit math/language attitudes

In this study, the explicit math attitude and explicit language attitude were measured using the semantic differentiation scale, which consisted of paired positive and negative words at both ends of the scale. Each scale had five questions, with a lowest score of 5 points, a highest score of 35 points, and a midpoint of 20 points. Scores lower than 20 points indicated a positive attitude towards the test object, while scores higher than 20 points indicated a negative attitude. In the corresponding IAT, the same five pairs of words were also used as attribute categories. A positive D value indicated a negative attitude towards math and a positive attitude towards language, while a negative D value indicated a positive attitude towards math and a negative attitude towards language. The results of all participants in the three tests are shown in Table54.

Table54 Descriptive statistics of college students' explicit and implicit math/language attitudes

	N	Min	Max	Mean	SD
EMA	345	5	35	14.14	8.175
ELA	345	5	35	11.90	6.868
IAT4	161	-2.681	1.953	.10	.362

Note: EMA=Explicit Math Attitude; ELA=Explicit Language Attitude.

7.7.2. Explicit math attitude of the CSGS college students

7.7.2.1. Comparison of explicit math attitude between CSGS and SGS college students

To understand the explicit math attitude of the CSGS college students, the score of explicit math attitude of the CSGS college students and that of the SGS college students were compared. Furthermore, as the median value of the explicit math attitude semantic differentiation scale is 20, indicating neither positive nor negative attitudes towards math, a one-sample t-test on the score of explicit math attitude of the CSGS and the SGS college students were conducted using 20 as the test value. The results are presented in Table55.

Table55 Comparison of explicit math attitude between the CSGS and the SGS college students (M±SD)

	EMA	n	t (median=20)	P	Cohen d
CSGS college Students	11.50±7.164	119	-12.950***	<.001	-1.187
SGS college Students	15.53±8.344	226	-8.052***	<.001	-.536
t	-4.693***				
P	<.001				
Cohen d	-.507				

Note: ***=P<.001.

Table55 shows that the score of the CSGS college students in explicit math attitude is significantly lower than that of the SGS college students ($t=-4.693$, $P<.001$), with an effect size of $-.507$. This indicates that the CSGS college students generally hold a more positive explicit attitude towards math than the SGS college students. Thus, H11 has been confirmed. Additionally, both groups of students scored significantly lower than the median value of 20 in explicit math attitude ($t=-12.950$, $P<.001$; $t=-8.052$, $P<.001$), and the effect size for the CSGS college students was even larger (Cohen $d=-1.187$), suggesting that their explicit math attitude is generally positive.

7.7.2.2. Influence of various variables on explicit math attitude

To investigate the influence of sex, major, residence, and their interaction on participants' explicit math attitude, a multi-way ANOVA was conducted. The results are presented in Table56 and Figure21.

Table56 Multi-way ANOVA of explicit math attitude

	SS	df	MS	F	P	$\eta^2_{partial}$
Sex	28.680	1	28.680	.496	.482	.001
Major	1919.431	1	1919.431	33.192***	<.001	.090
Residence	42.203	1	42.203	.730	.394	.002
Sex*Major	56.111	1	56.111	.970	.325	.003
Sex*Residence	6.748	1	6.748	.117	.733	.000
Major*Residence	17.799	1	17.799	.308	.579	.001
Sex*Major*Residence	6.516	1	6.516	.113	.737	.000

Note: ***=P <.001

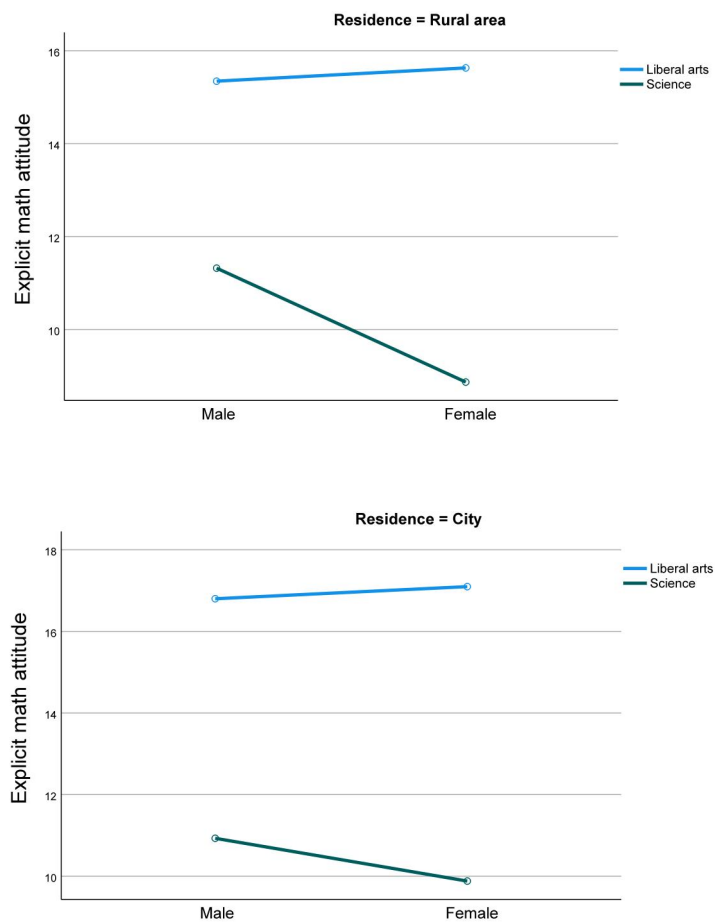

Figure21 Effects of sex, major, residence and their interaction on explicit math attitudes

The results presented in Table56 indicate that the main effect of major is significant ($F=33.192$, $P<.001$, $\eta^2_{\text{partial}}=.090$), while the main effects of sex and residence are not significant. Furthermore, the interaction effect between the three variables is also not significant. As shown in Figure21, college students majoring in science have lower scores than those majoring in liberal arts, regardless of their place of residence. This finding suggests that students majoring in science have a more positive explicit attitude towards math than those majoring in liberal arts. Additionally, it can be observed from Figure21 that there is little difference in the explicit math attitude between male and female majoring in liberal arts, whereas there is a significant difference between male and female majoring in science. Specifically, female majoring in science has lower scores than male, indicating that female majoring in science have a more positive explicit attitude towards math.

7.7.2.3. Further exploration of the Influence of sex and major on explicit math attitude

To further investigate the potential influence of sex and major on explicit math attitudes, the combination of major and sex variables was divided into four groups: liberal arts male, liberal arts female, science male, and science female. The average score of the four groups of college students on the explicit math attitude scale is shown in Figure22. One-way ANOVA and LSD multiple comparisons were conducted on their scores, and the results are presented in Table57 and Table58, respectively.

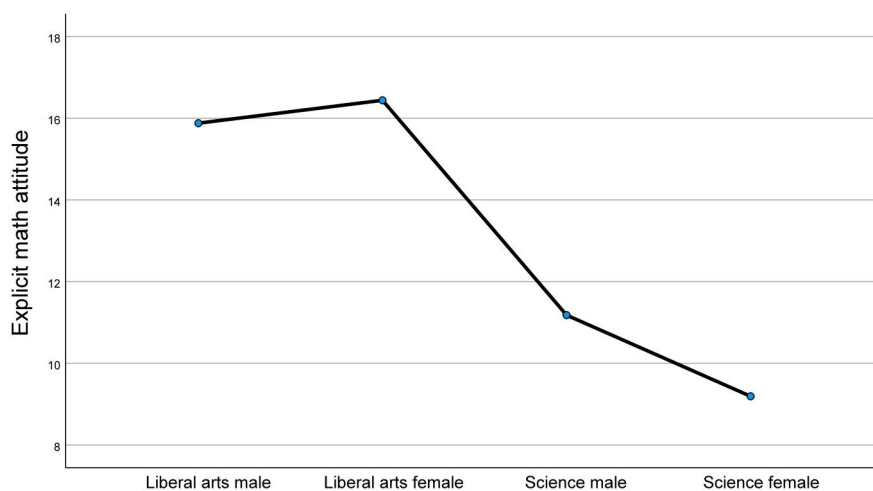

Figure22 Average score of explicit math attitude of four groups college students

Table57 One-way ANOVA of explicit math attitude

	M±SD		SS	df	MS	F	P	η^2
Liberal arts male	15.88±8.177	Between Groups	3363.030	3	1121.010	19.477***	<.001	.146
Liberal arts female	16.44±8.334	Within Groups	19626.292	341	57.555			
Science male	11.18±6.981	Total	22989.322	344				
Science female	9.19±5.321							

Note: ***=P <.001

Table57 shows significant differences in explicit math attitude scores among the four groups of college students (F=19.477, P<.001, η^2 =.146).

Table58 Multiple comparisons of four groups college students' explicit math attitude

		Mean Difference	SE	P
	Liberal arts female	-.560	1.308	.669
Liberal arts male	Science male	4.699*	1.697	.006
	Science female	6.686*	1.463	<.001

	Liberal arts male	.560	1.308	.669
Liberal arts female	Science male	5.259*	1.335	<.001
	Science female	7.246*	1.023	<.001

	Liberal arts male	-4.699*	1.697	.006
Science male	Liberal arts female	-5.259*	1.335	<.001
	Science female	1.987	1.488	.183

	Liberal arts male	-6.686*	1.463	<.001
Science female	Liberal arts female	-7.246*	1.023	<.001
	Science male	-1.987	1.488	.183

Note: *The mean difference is significant at the 0.05 level.

Table58 shows that significant differences exist in explicit math attitude scores between liberal arts male and science male, science female, as well as between liberal arts female and science male, science female. However, the differences in explicit math attitudes between male and female in both liberal arts and science did not reach statistical significance. Thus, it appears that differences in explicit mathematics attitudes mainly occur among different majors, with male and female in science generally holding more positive attitudes towards math than those in liberal arts. Moreover, the lower the score of explicit math attitude, the more positive the attitude is. The four groups of college students are ranked from low to high as follows: science female<science male<liberal arts male< liberal arts female, indicating that female in science exhibit the most positive explicit attitude towards math, while female in liberal arts exhibit the most negative explicit attitude towards math. However, it is important to note that even so, the explicit math attitudes of the four groups of college students have not reached the median value of 20, which indicates that, on the whole, the four groups of college students exhibit a positive attitude towards math.

7.7.3. Explicit language attitude of the CSGS college students

7.7.3.1. Comparison of explicit language attitude between the CSGS and the SGS college students

Table59 Comparison of explicit language attitude between the CSGS and the SGS college students (M±SD)

	ELA	n	t (median=20)	P	Cohen d
CSGS college Students	10.86±6.301	119	-15.829***	<.001	-1.451
SGS college Students	12.45±7.101	226	-15.992***	<.001	-1.064
t	-2.053*				
P	.020				
Cohen d	-.233				

Note: ***=P<.001.

To investigate the explicit language attitudes of the CSGS college students, their scores were

compared to those of the SGS college students. As the median value of the explicit language attitude semantic differentiation scale is 20, indicating that participants have neutral attitudes towards language, this value was used as a test value for conducting a one-sample t-test on the scores of explicit language attitudes of the CSGS and the SGS college students. The results of the test are presented in Table59. It indicates that the CSGS college students have a significantly lower score in explicit language attitude compared to the SGS college students ($t=-2.053$, $P=.020$, Cohen $d=-.233$), suggesting that the CSGS college students generally have a more positive explicit attitude towards language than the SGS college students. Thus, H12 has been confirmed. Moreover, both the CSGS and SGS college students scored significantly lower than the median value of 20 in explicit language attitude ($t=-15.829$, $P<.001$, Cohen $d=-1.451$; $t=-15.992$, $P<.001$, Cohen $d=-1.064$), indicating that their explicit language attitude is generally positive.

7.7.3.2. Impact of various variables on explicit language attitude

To investigate the influence of sex, major, residence, and their interaction on participants' explicit language attitudes, a multi-way ANOVA was conducted. The results are presented in Table60 and Figure23.

Table60 Multi-way ANOVA of explicit language attitude

	SS	df	MS	F	P	$\eta^2_{partial}$
Sex	339.579	1	339.579	7.799**	.006	.023
Major	307.626	1	307.626	7.065**	.008	.021
Residence	37.229	1	37.229	0.855	.356	.003
Sex*Major	433.312	1	433.312	9.952**	.002	.029
Sex*Residence	211.728	1	211.728	4.863*	.028	.014
Major*Residence	60.701	1	60.701	1.394	.239	.004
Sex*Major*Residence	124.717	1	124.717	2.864	.091	.008

Note: *= $P<.05$; **= $P<.01$.

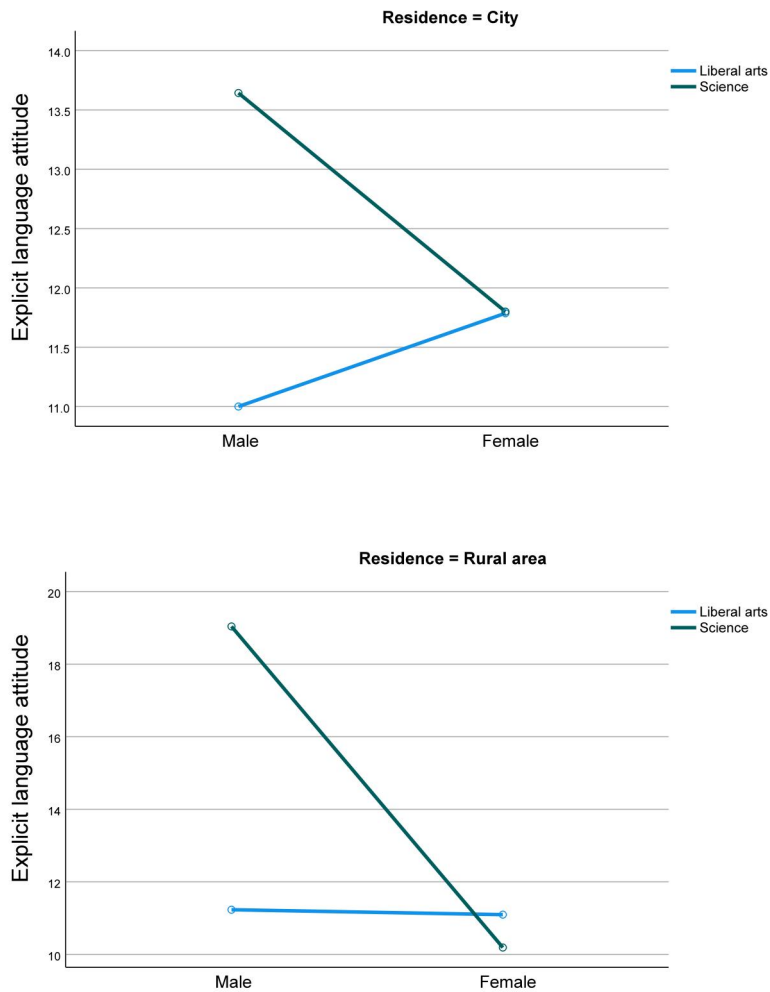

Figure23 Effects of sex, major, residence and their interaction on explicit language attitudes

The results presented in Table60 indicate that the main effects of sex ($F=7.799$, $P=.006$, $\eta^2_{\text{partial}}=.023$) and major ($F=7.065$, $P=.008$, $\eta^2_{\text{partial}}=.021$) are significant, while the main effect of residence ($F=.855$, $P=.356$, $\eta^2_{\text{partial}}=.003$) is not significant. The interaction effects of sex*major ($F=9.952$, $P=.002$, $\eta^2_{\text{partial}}=.029$) and sex*residence ($F=4.863$, $P=.028$, $\eta^2_{\text{partial}}=.014$) are significant, while the interaction effects of major*residence ($F=1.394$, $P=.239$, $\eta^2_{\text{partial}}=.004$) and sex*major*residence ($F=2.864$, $P=.091$, $\eta^2_{\text{partial}}=.008$) are not significant. These findings suggest that female college students have a more positive explicit attitude towards language than male college students and students majoring in liberal arts have more positive explicit attitude towards language than students majoring in science. This aligns with the general trend of women displaying a more positive attitude towards language than men, and liberal arts students displaying a more positive attitude towards language than science students.

Surprisingly, however, women majoring in liberal arts do not display a more positive attitude towards language than women in science. In fact, women in science living in rural areas display a more positive attitude towards language than women in liberal arts who also live in rural areas. Furthermore, women in liberal arts living in city display a more negative attitude towards language than men in liberal arts.

7.7.3.3. Further exploration of the influence of sex and major on explicit language attitude

To further explore the possible impact of sex and major on explicit language attitude, the combination of major and sex variables was divided into four groups, namely liberal arts male, liberal arts female, science male, and science female. The average scores of these four groups of college students on the explicit language attitude scale are presented in Figure24. A one-way ANOVA and LSD multiple comparisons were performed on their scores, as shown in Table61 and Table62.

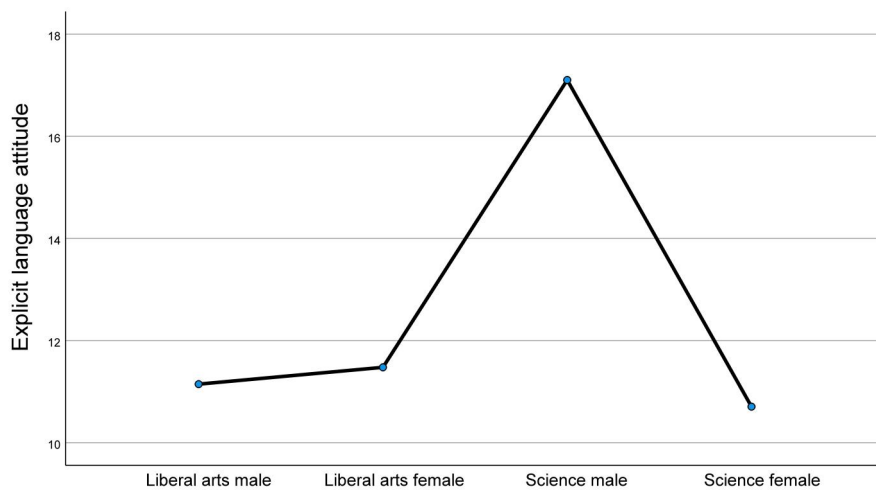

Figure24 Average score of explicit language attitude of four groups college students

Table61 One-way ANOVA of explicit language attitude

	M±SD		SS	df	MS	F	P	η^2
Liberal arts male	11.15±6.616	Between Groups	1223.878	3	407.959	9.273***	<.001	.075
Liberal arts female	11.45±6.263							
Science male	17.10±8.923	Total	16225.449	344				
Science female	10.71±6.167							

Note: ***=P<.001.

Table62 Multiple comparisons of four groups college students' explicit language attitude

		Mean Difference	SE	P
	Liberal arts female	-.330	1.144	.773
Liberal arts male	Science male	-5.956*	1.484	<.001
	Science female	.441	1.279	.730

	Liberal arts male	.330	1.144	.773
Liberal arts female	Science male	-5.627*	1.168	<.001
	Science female	.771	.894	.389

	Liberal arts male	5.956*	1.484	<.001
Science male	Liberal arts female	5.627*	1.168	<.001
	Science female	6.397*	1.301	<.001

	Liberal arts male	-.441	1.279	.730
Science female	Liberal arts female	-.771	.894	.389
	Science male	-6.397*	1.301	<.001

Note: *The mean difference is significant at the 0.05 level.

Table61 reveals significant differences in the scores of explicit language attitudes among the four groups of college students ($F=9.273$, $P<.001$, $\eta^2=.075$). Table62 indicates that the explicit language attitudes between liberal arts male and science male differ significantly, as do between liberal arts female and science male. The explicit language attitudes between science male and the other three groups also show significant differences, as do the explicit language attitudes between science male and science female. The scores of the four groups of college students can be ranked from low to high as follows: science female<liberal arts male<liberal arts female<science male. This suggests that female students in science have the most positive explicit attitude towards language, while male students in science have the most negative

explicit attitude towards language. However, it should be noted that the explicit language attitudes of the four groups of college students have not reached the median value of 20, indicating that the four groups of college students generally have a positive attitude towards language.

7.7.4. Implicit math/language attitudes of the CSGS college students

7.7.4.1. Comparison of IAT4 between the CSGS and the SGS college students

To investigate whether there are differences in implicit math/language attitudes between the CSGS and the SGS college students, their scores on the IAT4 were compared. In addition, the scores of both groups were compared to the median value of 0 on the IAT4.

Table63 Comparison of IAT4 between the CSGS and the SGS college students (M±SD)

	IAT4	n	t (median=0)	P	Cohen d
CSGS college Students	.110±.293	92	3.604***	<.001	.376
SGS college Students	.075±.438	69	1.419	.080	.171
t	.609				
P	.272				
Cohen d	.097				

Note: ***=P<.001.

Table63 confirms that there is no significant difference in IAT4 scores between the CSGS and the SGS students (t=.609, P=.272, Cohen d=.097). Thus, H13 has not been confirmed. However, when compared to the median value of 0, the CSGS students (t=3.604, P=<.001, Cohen d=.376) had significantly higher scores than the middle value of 0, while the SGS students (t=1.419, P=.080, Cohen d=.171) did not show such a difference.

7.7.4.2. Impact of various variables on implicit math/language attitudes

To further investigate the influence of sex, major, residence, and their interaction on participants' implicit math/language attitudes, a multi-way ANOVA was conducted. The results are presented in Table64 and Figure25.

Table64 Multi-way ANOVA of implicit math/language attitudes

	SS	df	MS	F	P	$\eta^2_{partial}$
Sex	.211	1	.211	1.654	.200	.011
Major	.907	1	.907	7.108**	.009	.044
Residence	.001	1	.001	.012	.914	.000
Sex*Major	.298	1	.298	2.336	.129	.015
Sex*Residence	.077	1	.077	.600	.440	.004
Major*Residence	.409	1	.409	3.204	.075	.021
Sex*Major*Residence	.004	1	.004	.030	.863	.000

Note: **= $P < .01$.

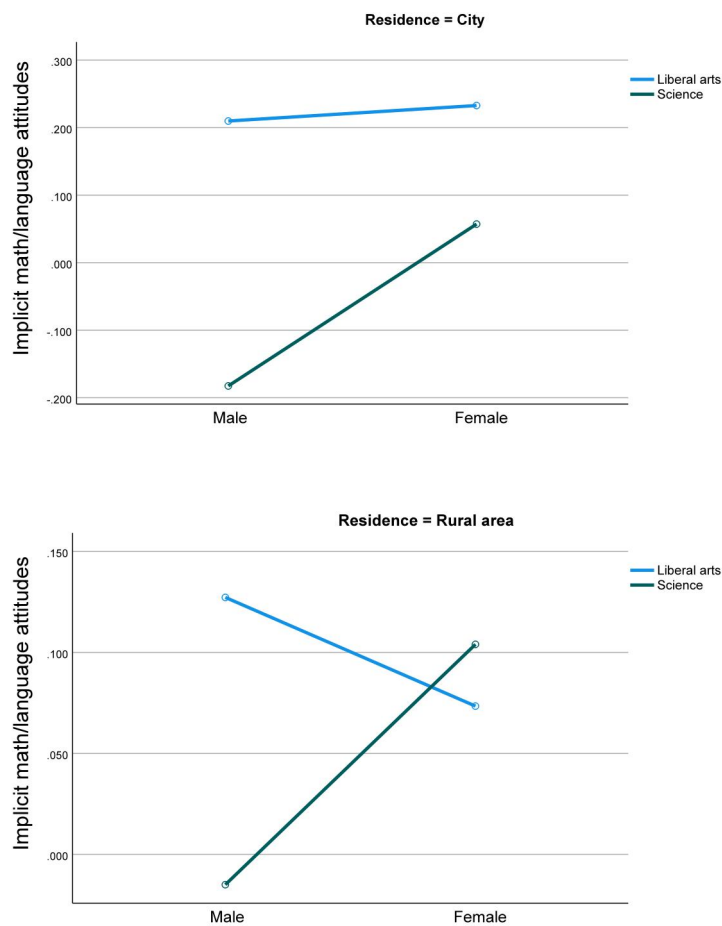

Figure25 Effects of sex, major, residence and their interaction on implicit math/language attitudes

Table64 shows that only the main effect of major ($F=7.108$, $P=.009$, $\eta^2_{partial}=.044$) reached a

significant level, while other variables and interaction effects did not. This means that there was a significant difference in IAT4 scores between liberal arts and science college students, as confirmed by Figure25.

7.7.4.3. Further exploration of the influence of sex and major on implicit math/language attitudes

To further explore the possible impact of sex and major on implicit math/language attitudes, the combination of major and sex variables was divided into four groups, namely liberal arts male, liberal arts female, science male, and science female. The average scores of these four groups of college students on the IAT4 are presented in Figure26. A one-way ANOVA was performed on their scores, as shown in Table65.

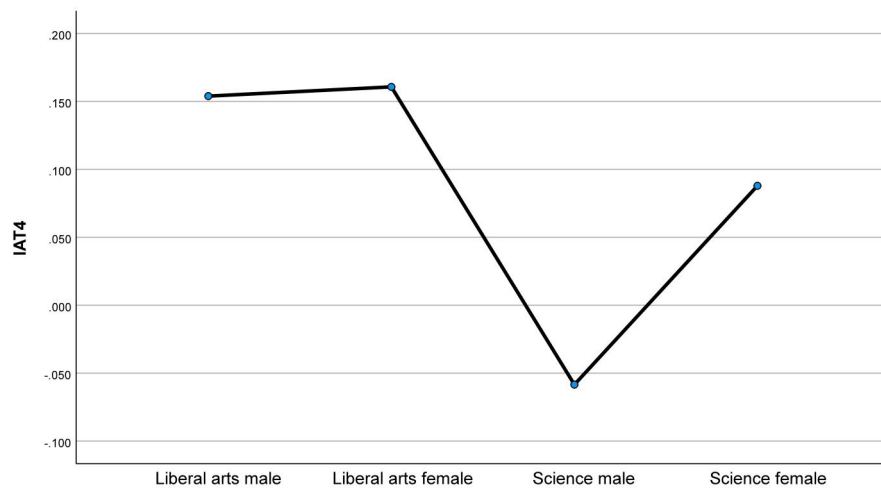

Figure26 Average score of IAT4 of four groups college students

Table65 One-way ANOVA of IAT4

	M±SD		SS	df	MS	F	P	η^2
Liberal arts male	.154±.368	Between groups	.927	3	.309	2.425	.068	.044
Liberal arts female	.161±.493							
Science male	-.058±.299	Within groups	29.012	357	.127			
Science female	.088±.247							
		Total	20.940	160				

Table65 shows that there were variations in the IAT4 scores among the four groups of college students, but these differences were not statistically significant ($F=2.425$, $P=.068$, $\eta^2=.044$).

7.7.5. The relationship between gender stereotypes and math/language attitudes

7.7.5.1. Correlation analysis between gender stereotypes and math/language attitudes of the CSGS college students.

To investigate the relationship between gender stereotypes and math/language attitudes of the CSGS college students, correlation analyses were conducted between the scores of explicit and implicit gender stereotypes and the scores of explicit and implicit math/language attitudes, as shown in Table66. The results indicate that ESMGS, IAT1, AIT2, and IAT3 are all significantly correlated with IAT4. EMGS, IAT1, and EMA are significantly correlated, as well as EMGS, IAT1, and ELA.

Table66 Correlation matrix (CSGS college students)

	ESMGS	ELFGS	EMGS	ELGS	IAT1	IAT2	IAT3	IAT4	EMA	ELA
ESMGS	1	.574**	.181*	-.019	-.005	-.002	-.040	-.293**	.059	.076
ELFGS		1	.140	.295**	-.129	-.059	-.068	-.154	-.059	.045
EMGS			1	.598**	.093	-.194*	-.057	.006	.280**	.187*
ELGS				1	.004	-.253**	-.168	-.094	.140	.132
IAT1					1	.565**	.604**	.397**	.291**	.181*
IAT2						1	.661**	.452**	-.049	.046
IAT3							1	.560**	-.036	.044
IAT4								1	.089	.073
EMA									1	.474**
ELA										1

Note: *= $P<.05$; **= $P<.01$.

ESMGS=Explicit Science Male Gender Stereotypes; ELFGS=Explicit Liberal Arts Female Gender

Stereotypes; EMGS=Explicit Math Gender Stereotypes; ELGS=Explicit Language Gender Stereotypes; EMA=Explicit Math Attitude; ELA=Explicit Language Attitude.

7.7.5.2. Multiple linear regression of gender stereotypes on math/language attitudes of the CSGS college students

Based on the results of the correlation analysis, this study aims to investigate which gender stereotype-related variables have a predictive effect on math/language attitudes of the CSGS college students using stepwise multiple linear regression. All gender stereotype-related variables in the correlation matrix will be used as independent variables, while explicit math attitudes, explicit language attitudes and IAT4 will be used as the dependent variable. The results are presented in Table67, Table68 and Table69.

Table67 Multiple linear regression of gender stereotypes on explicit math attitude

Dependent variable	Variables entered	B	β	t	VIF	F	R ² _{adj}
EMA	EMGS	.349	.312	3.330***	1.034	10.940*** ^a	.253 ^a
	IAT1	9.325	.310	3.324***	1.027		
	IAT3	-5.337	-.197	-2.126**	1.008		

Note: ***=P<.001.

EMGS=Explicit Math Gender Stereotypes; EMA=Explicit Math Attitude.

a: Predictor (Constant, EMGS, IAT1, IAT3)

Table68 Multiple linear regression of gender stereotypes on explicit language attitude

Dependent variable	Variables entered	B	β	t	VIF	F	R ² _{adj}
ELA	EMGS	.258	.252	2.425*	1.000	5.880 ^a	.053 ^a

Note: *=P<.05.

EMGS=Explicit Math Gender Stereotypes; ELA=Explicit Language Attitude.

a: Predictor (Constant, EMGS)

Table69 Multiple linear regression of gender stereotypes on implicit math/language attitudes

Dependent variable	Variables entered	B	β	t	VIF	F	R ² _{adj}
IAT4	ESMGS	-.009	-.241	-2.338*	1.027	5.633**a	.096 ^a
	IAT1	-.198	-.206	-1.998*	1.027		

Note: *= $P < .05$; **= $P < .01$.

ESMGS=Explicit Science Male Gender Stereotypes.

a: Predictor (Constant, ESMGS, IAT1)

Based on the results presented in Table67, the stepwise multiple regression analysis revealed that the final regression model included three independent variables (EMGS, IAT1, IAT3). The VIF values of these variables were all close to 1 (VIF=1.034; VIF=1.027; VIF=1.008), indicating the absence of multicollinearity. The adjusted R-squared value was .253, indicating that the three independent variables accounted for 25.3% of the variance in the dependent variable. Specifically, explicit math gender stereotypes, implicit trait gender stereotypes, and implicit math/language gender stereotypes were found to significantly predict the explicit math attitudes of the CSGS college students ($F=10.940$). The predictive power of these variables, ranked in descending order, was $EMGS(\beta=.312) > IAT1(\beta=.310) > IAT3(\beta=-.197)$.

Table68 shows, in the stepwise regression analysis with explicit language attitude as the dependent variable, only EMGS finally entered the regression model. The adjusted R-squared value was .053, indicating that EMGS accounted for 5.3% of the variance in the dependent variable. Specifically, explicit math gender stereotypes were found to significantly predict the explicit language attitude of the CSGS college students ($F=5.880$).

Table69 shows, in the stepwise regression analysis with IAT4 as the dependent variable, ESMGS and IAT1 finally entered the regression model. The VIF values of these variables were all close to 1 (VIF=1.027; VIF=1.027), indicating the absence of multicollinearity. The adjusted R-squared value is .096, indicating that these two independent variables accounted for 9.3% of the variance in the dependent variable. Specifically, explicit science male gender stereotypes (ESMGS) and implicit trait gender stereotypes are found to significantly predict

the implicit math/language attitudes of the CSGS college students($F=5.633$).

Overall, both explicit and implicit variables of gender stereotypes can predict explicit and implicit math/language attitudes, and there is no phenomenon that variables of implicit gender stereotypes can better predict. Thus, H14 has not been confirmed.

7.8. Discussion

7.8.1. Positive explicit math and language attitudes of college Students

The scores of CSGS college students in their explicit attitudes towards math and language are significantly lower than the median value of 20. This indicates that CSGS college students have a positive attitude towards both math and language. SGS college students exhibit similar tendencies. These findings suggest that, overall, college students have a positive explicit attitude towards both math and language. They generally believe that math and language are enjoyable and lovable.

However, there are significant differences in this positive explicit attitude towards math and language between CSGS and SGS college students, between college students of different genders, and between college students of different majors. Specifically, the CSGS college students have more positive explicit math and language attitudes than SGS college students; The explicit math attitude of science college students is more positive than that of liberal arts college students; The explicit language attitude of liberal arts college students is more positive than that of science college students; Female college students have more positive explicit language attitudes than male college students.

Surprisingly, there are only major differences in explicit math attitudes, but no gender differences, which is inconsistent with some studies. Many studies believe that women are more negative and less confident about math, and believe that this math attitude is an important precursor that leads to differences in math performance and participation rates between men and women(Hyde et al., 1990; Lin & Huang, 2016; Nosek et al., 2002). Although there is no sex difference in achievement, men have a more positive attitude towards math (Else-Quest et al., 2010; Jameson et al., 2022). At the same time, math attitude is also an important predictor of choice of study field (Maple & Stage, 1991). However, the current study does not support sex differences in explicit math attitudes. Although the most negative attitude is expressed by liberal arts female, the most positive attitude towards math is

expressed by science female college students rather than science male college students.

In addition, it should be noted that sex differences in math attitudes are under focus, but few studies have focused on sex differences in language attitudes. In this study, there is sex differences in explicit language attitudes, namely, female college students have a more positive attitude towards language than male college students, which is consistent with some existing studies and people's daily gender stereotypes. Some research has shown that women have more confidence in their language abilities than men, and have higher language-related self-concept, while men do not (Durik et al., 2006; Retelsdorf et al., 2015). Of course, the research results are not consistent, and some studies have shown that there is no difference in language attitudes between men and women (Rachmawaty et al., 2020). In this study, current evidence supports the conclusion that explicit language attitudes have sex differences.

7.8.2. College students' generally negative implicit attitudes towards math

As mentioned earlier, this study found that college students generally have positive explicit attitudes towards math and language. What about implicit math/language attitudes through IAT? As a result, this study found that college students generally have a negative implicit attitude towards math and a positive implicit attitude towards language. Nosek et al. (2002) reported the implicit numerical dislike effect, and in two IAT designed by him and his colleagues, participants both showed surprisingly negative implicit evaluations of digits over letters. Whether this numerical dislike effect is universal and related to the negative implicit attitude towards math in this study is worth further research.

This study also shows that there are major differences in implicit math/language attitudes, with liberal arts college students exhibiting a more negative implicit attitude towards math and a more positive implicit attitude towards language than science college students. However, sex differences have not been detected, which is inconsistent with some previous studies. Some previous studies have found that women exhibit a stronger negative implicit attitude towards math than men (Cvencek et al., 2021; Nosek et al., 2002). If implicit and explicit attitudes are two independent constructs, it is reasonable that participants differ in their explicit and implicit attitudes. As in this study, there are gender and major differences in explicit math and language attitudes, while there are neither gender nor major differences in implicit math/language attitudes, which means that all college students share the same implicit math/language

attitudes. This just shows that explicit math and language attitudes and implicit math/language attitudes are different constructs. College students hold positive explicit attitudes towards math and language, but they consistently hold negative implicit attitudes towards math and positive implicit attitudes towards language.

7.8.3. The predictive effect of explicit and implicit gender stereotypes on math/language attitudes

Many theories of math and language participation and achievement are based on the assumption that gender stereotypes play an important role in shaping math and language attitudes (Steele, 1998). However, this hypothesis is difficult to test because participants often explicitly deny gender stereotypes. This study attempts to test this hypothesis by measuring explicit and implicit gender stereotypes using both direct and indirect methods. As mentioned earlier, there may be an experimental dissociation between explicit and implicit gender stereotypes, which means that participants exhibit different performance in explicit and implicit gender stereotypes. So, are explicit gender stereotypes or implicit gender stereotypes more predictive of math and language attitudes? Study has shown that explicit gender stereotypes have no predictive power on explicit math attitudes, while implicit gender stereotypes do not (Nosek et al., 2002). In this study, a stepwise regression method was used to select variables that can predict explicit and implicit math and language attitudes from a large number of explicit and implicit gender stereotypes. The results showed that both some explicit and implicit gender stereotypes could predict explicit and implicit math and language attitudes, while implicit gender stereotypes did not exhibit better predictive ability. For this contradictory research result, further research is needed to verify it.

7.9. Conclusion

- a) There are differences in explicit math between the CSGS and the SGS college students. H11 has been confirmed.
- b) There are differences in explicit language between the CSGS and the SGS college students. H12 has been confirmed.
- c) There are not differences in implicit math/language between the CSGS and the SGS college students. H13 has not been confirmed.
- d) Both explicit gender stereotypes and implicit gender stereotypes may predict

mathematical/language attitudes. H14 has not been confirmed.

- e) College students generally hold positive explicit math attitudes and language attitudes, and this explicit math and language attitude has gender or major differences.
- f) College students generally hold a negative implicit attitude towards math and a positive implicit attitude towards language, and no major or sex differences were found.

8. The Relationship between Gender Stereotypes and Math/English Performance of the CSGS College Students

8.1. Research purpose

Analyzing the relationship between gender stereotypes and math and English performance, and explore the predictive ability of explicit and implicit gender stereotypes on math and English performance.

8.2. Research hypothesis

This study will verify the 2 of the 18 research hypotheses, which are:

H15: The explicit gender stereotypes cannot predict math performance of the CSGS college students, while the implicit gender stereotypes can.

H16: The explicit gender stereotypes cannot predict English performance of the CSGS college students, while the implicit gender stereotypes can.

8.3. Participants

See 6.3.

8.4. Instruments

The instruments needed in this study have been introduced in the previous text, including the following:

- a) Explicit Subject Gender Stereotypes Scale (ESGS)
- b) Explicit Math Gender Stereotypes Scale (EMGS)
- c) Explicit Language Gender Stereotypes Scale (ELGS)
- d) IAT of implicit trait gender stereotypes (IAT1)
- e) IAT of implicit subject gender stereotypes (IAT2)
- f) IAT of implicit math/language gender stereotypes (IAT3)

8.5. Research procedure

The research process is shown in section 6.5.

8.6. Data processing

The data collected in this study were statistically analyzed with SPSS28.0 software. According to the research hypothesis and data conditions, this study mainly carries out the correlation analysis and multiple linear regression.

8.7. Results

8.7.1. The relationship between gender stereotypes and math/English performance of the CSGS college students

8.7.1.1. Correlation analysis between gender stereotypes and math/English performance of the CSGS college students

To investigate the relationship between gender stereotypes and math/English performance of the CSGS college students, correlation analyses were conducted between the scores of explicit and implicit gender stereotypes and the scores of math/English, as shown in Table70. The results indicate that EMGS($r=-.184$) and IAT1($r=-.242$) are all significantly correlated with MP. This means that explicit math gender stereotypes are significantly negatively correlated with math performance, while implicit trait gender stereotypes are significantly negatively correlated with math performance too. However, none of the explicit and implicit gender stereotype variables are significantly associated with EP.

Table70 The correlation between various variables of gender stereotypes and math/English performance (CSGS)

	ESMGS	ELFGS	EMGS	ELGS	IAT1	IAT2	IAT3
MP	.144	.089	-.184*	-.065	-.242**	-.063	-.120
EP	.072	-.010	-.002	-.039	.037	.045	.037

Note: *= $P<.05$; **= $P<.01$.

ESMGS=Explicit Science Male Gender Stereotypes; ELFGS=Explicit Liberal Arts Female Gender Stereotypes; EMGS=Explicit Math Gender Stereotypes; ELGS=Explicit Language Gender Stereotypes; MP=Math Performance; EP=English Performance.

8.7.1.2. Multiple linear regression of gender stereotypes on math performance of the CSGS college student

Based on the results of the correlation analysis, this study aims to investigate which gender stereotype-related variables have a predictive effect on math performance of the CSGS college students using stepwise multiple linear regression. All gender stereotype-related variables in the correlation matrix will be used as independent variables, while math performance will be

used as the dependent variable. The results are presented in Table71.

Table71 Multiple linear regression of gender stereotypes on math performance (CSGS)

Dependent variable	Variables entered	B	β	t	VIF	F	R^2_{adj}
MP	IAT1	-8.796	-.243	-2.378*	1.000	4.997**a	.083 ^a
	ELGS	-.401	-.216	-2.115*	1.000		

Note: *=P<.05; **=P<.01.

ELGS=Explicit Language Gender Stereotypes; MP=Math Performance.

a: Predictor (Constant, IAT1, ELGS)

Based on the results presented in Table71, the stepwise multiple regression analysis revealed that the final regression model included two independent variables (IAT1, ELGS). The VIF values of these variables were all close to 1(VIF=1.000; VIF=1.000), indicating the absence of multicollinearity. The adjusted R-squared value was .083, indicating that the two independent variables accounted for 8.3% of the variance in the dependent variable. Specifically, explicit language gender stereotypes and implicit trait gender stereotypes are found to significantly predict the math performance of the CSGS college students(F=4.997). The predictive power of these variables, ranked in descending order, is IAT1(β =-.243)>ELGS(β =-.216). Both explicit and implicit gender stereotypes have predictive power on CSGS college students' math performance. Thus, H14 has not been confirmed.

8.7.1.3. Multiple linear regression of gender stereotypes on English performance of the CSGS college student

To investigate which gender stereotype-related variables have a predictive effect on English performance of the CSGS college students, stepwise multiple linear regression is conducted. All gender stereotype-related variables in the correlation matrix will be used as independent variables, while English performance will be used as the dependent variable. Finally, none of the variables entered the regression model. Both explicit and implicit gender stereotypes have no predictive power on CSGS college students' English performance. Thus, H15 has not been

confirmed.

8.7.2. The relationship between gender stereotypes and math/English performance of male college students

8.7.2.1. Correlation analysis between gender stereotypes and math/English performance of male college students

To investigate the relationship between gender stereotypes and math/English performance of male college students, correlation analyses were conducted between the scores of explicit and implicit gender stereotypes and the scores of math/English, as shown in Table72. The results indicate that ESMGS($r=-.287$) and ELGS($r=-.318$) are all significantly correlated with EP. This means that explicit math gender stereotypes and explicit language gender stereotypes are significantly negatively correlated with English performance. However, none of the explicit and implicit gender stereotype variables are significantly associated with MP.

Table72 The correlation between various variables of gender stereotypes and math/ English performance(male)

	ESMGS	ELFGS	EMGS	ELGS	IAT1	IAT2	IAT3
MP	.188	.121	-.015	-.056	-.084	-.004	-.047
EP	-.081	-.138	-.287*	-.318**	.080	-.050	.051

Note: *= $P<.05$; **= $P<.01$.

ESMGS=Explicit Science Male Gender Stereotypes; ELFGS=Explicit Liberal Arts Female Gender Stereotypes; EMGS=Explicit Math Gender Stereotypes; ELGS=Explicit Language Gender Stereotypes; MP=Math Performance; EP=English Performance.

8.7.2.2. Multiple linear regression of gender stereotypes on math performance of male college student

To investigate which gender stereotype-related variables have a predictive power on math performance of male college students, stepwise multiple linear regression is conducted. All gender stereotype-related variables in the correlation matrix will be used as independent variables, while math performance will be used as the dependent variable. As a result, none of

the variables entered the regression model.

8.7.2.3. Multiple linear regression of gender stereotypes on English performance of male college student

To investigate which gender stereotype-related variables have a predictive power on English performance of male college students, stepwise multiple linear regression is conducted. All gender stereotype-related variables in the correlation matrix will be used as independent variables, while English performance will be used as the dependent variable. The results are presented in Table73.

Table73 Multiple linear regression of gender stereotypes on English performance(male)

Dependent variable	Variables entered	B	β	t	VIF	F	R ² _{adj}
EP	ELGS	-1.014	-.408	-3.190**	1.000	10.177**a	.150

Note: **=P<.01.

ELGS=Explicit Language Gender Stereotypes; EP=English Performance.

a: Predictor (Constant, ELGS)

Based on the results presented in Table73, the stepwise multiple regression analysis revealed that the final regression model included only one independent variables (ELGS). The VIF values of ELGS is all close to 1(VIF=1.000), indicating the absence of multicollinearity. The adjusted R-squared value was .150, indicating that the two independent variables accounted for 15% of the variance in the dependent variable. Specifically, explicit language gender stereotypes is found to significantly predict the English performance of male college students(F=10.177).

8.7.3. The relationship between gender stereotypes and math/English performance of female college students

8.7.3.1. Correlation analysis between gender stereotypes and math/English performance of female college students

To investigate the relationship between gender stereotypes and math/English performance of

female college students, correlation analyses were conducted between the scores of explicit and implicit gender stereotypes and the scores of math/English, as shown in Table74. The results indicate that EMGS($r=.142$) is significantly correlated with MP and ELFGS($r=.137$) is significantly correlated with EP. This means that explicit math gender stereotypes are significantly positively correlated with math performance, while explicit liberal arts female gender stereotypes are significantly positively correlated with English performance too.

Table74 The correlation between various variables of gender stereotypes and math/English scores(female)

	ESMGS	ELFGS	EMGS	ELGS	IAT1	IAT2	IAT3
MP	.077	.049	.142*	-.005	-.051	-.101	-.152
EP	.103	.137*	-.045	-.033	.106	.116	.085

Note: *= $P<.05$.

ESMGS=Explicit Science Male Gender Stereotypes; ELFGS=Explicit Liberal Arts Female Gender Stereotypes; EMGS=Explicit Math Gender Stereotypes; ELGS=Explicit Language Gender Stereotypes; MP=Math Performance; EP=English Performance.

8.7.3.2. Multiple linear regression of gender stereotypes on math performance of female college student

To investigate which gender stereotype-related variables have a predictive power on math performance of female college students, stepwise multiple linear regression is conducted. All gender stereotype-related variables in the correlation matrix will be used as independent variables, while math performance will be used as the dependent variable. Finally, none of the variables entered the regression model.

8.7.3.3. Multiple linear regression of gender stereotypes on English performance of male college student

To investigate which gender stereotype-related variables have a predictive power on English performance of female college students, stepwise multiple linear regression is conducted. All gender stereotype-related variables in the correlation matrix will be used as independent

variables, while math performance will be used as the dependent variable. The results are presented in Table75.

Table75 Multiple linear regression of gender stereotypes on English performance(female)

Dependent variable	Variables entered	B	β	t	VIF	F	R^2_{adj}
EP	ESMGS	.482	.246	2.550*	1.000	6.502 ^a	.051

Note: *=P<.05.

ESMGS=Explicit Science Male Gender Stereotypes; EP=English Performance.

a: Predictor (Constant, ESMGS)

Based on the results presented in Table75, the stepwise multiple regression analysis revealed that the final regression model included only one independent variables (ESMGS). The VIF values of ESMGS is all close to 1(VIF=1.000), indicating the absence of multicollinearity. The adjusted R-squared value was .051, indicating that the independent variables accounted for 5.1% of the variance in the dependent variable. Specifically, explicit science male gender stereotypes is found to significantly predict the English performance of female college students(F=6.502).

8.8. Discussion

8.8.1. Correlation between explicit/implicit gender stereotypes and math/English performance

Many studies have found that women perform poorly in mathematics compared to men(Contini et al., 2017; Liu & Wilson, 2009; Tsui, 2007). Similarly, studies also have found that men perform poorly in language compared to women(Brozo et al., 2014; De Gaer et al., 2007). This is consistent with gender stereotypes. Gender stereotypes are considered by researchers to be an important factor in explaining differences in math and language performance between men and women(Alan et al., 2018; Nosek et al., 2009). There have been many studies supporting the correlation between math gender stereotypes and math performance(Bedyńska et al., 2018; Levine & Pantoja, 2021). There are also studies that have found the role of gender in language learning(Becirovic, 2017). The current study continues to

explore the question: What is the relationship between gender stereotypes and academic performance, especially in math and language? The comprehensive measurement of explicit and implicit gender stereotypes (including trait gender stereotypes, subject gender stereotypes, and math/language gender stereotypes) enables the current study to comprehensively examine the relationship between gender stereotypes and math/English performance. The results showed that for CSGS college students, only explicit math gender stereotypes and implicit trait gender stereotypes are significantly negatively correlated with math performance, while the correlation between other variables and math performance is not significant. For English performance, its correlation with all explicit and implicit gender stereotypes is not significant. It can be concluded that for CSGS college students, the correlation between explicit and implicit gender stereotypes and their math/English performance is weak.

Studies have shown that the relationship between gender stereotypes and academic performance varies according to gender(Xie et al., 2022). Therefore, the current study further explored the correlation between gender stereotypes and math/English performance among male and female college students. The results show that all correlation coefficients are weak, with the highest correlation coefficient being only $-.318$. This indicates that the relationship between gender stereotypes and math/English performance is relatively weak for both male and female college students.

Overall, there is a weak correlation between gender stereotypes and math/English performance, regardless of whether it is CSGS college students or male and female college students.

8.8.2. The predictive power of explicit/implicit gender stereotypes on math/English performance

In addition to the correlation between gender stereotypes and math/English performance, the focus of the current study is whether gender stereotypes can predict math/English performance. The current study screened gender stereotype variables that predict math and English performance from numerous explicit and implicit gender stereotype variables, and is not limited to using math gender stereotypes to predict math performance, while language gender stereotypes to predict language performance. A stepwise regression was conducted using the math and English scores of the Chinese college entrance examination as dependent variables, and the variables of explicit and implicit gender stereotypes as independent variables. Finally,

it turns out that some variables of explicit and implicit gender stereotypes can indeed predict math or English performance, but more variables cannot predict math or English performance. Overall, gender stereotypes are not very strong predictors of math or English performance. This is partly consistent with some studies(Xie et al., 2022).

8.9. Conclusion

- a) Explicit and implicit gender stereotypes are generally weakly correlated with math and English performance.
- b) Explicit language gender stereotypes (ELGS) and implicit trait gender stereotypes (IAT1) can predict the math performance of CSGS college students. H14 has not been confirmed.
- c) Explicit and implicit gender stereotypes have no predictive power on the CSGS college students' English performance. H15 has not been confirmed.
- d) Explicit and implicit gender stereotypes have no predictive power on male college students' math performance.
- e) Explicit language gender stereotypes (ELGS) can predict the English performance of male college students.
- f) Explicit and implicit gender stereotypes have no predictive power on female college students' math performance.
- g) Explicit science male gender stereotypes (ESMGS) can predict the English performance of female college students

9. The Role of Math/Language Attitudes in the Relationship between Gender Stereotypes and Math/English Performance

9.1. Research purpose

Exploring whether math/language attitudes play a mediating role in relationship between gender stereotypes and math/English performance of the CSGS college students.

9.2. Research hypothesis

This study will verify the last 2 of the 18 research hypotheses, which are:

H17: Implicit and explicit math attitudes play a mediating role between gender stereotypes and math performance;

H18: Implicit and explicit math attitudes play a mediating role between gender stereotypes and English performance.

9.3. Participants

See 6.3..

9.4. Instruments

The instruments needed in this study have been introduced in the previous text, including the following:

- a) Explicit Math Attitude Scale (EMA)
- b) Explicit Language Attitude Scale (ELA)
- c) Explicit Subject Gender Stereotypes Scale (ESGS)
- d) Explicit Math Gender Stereotypes Scale (EMGS)
- e) Explicit Language Gender Stereotypes Scale (ELGS)
- f) IAT of implicit trait gender stereotypes (IAT1)
- g) IAT of implicit subject gender stereotypes (IAT2)
- h) IAT of implicit math/language gender stereotypes (IAT3)
- i) IAT of implicit math/language Attitude stereotypes (IAT4)

9.5. Research procedure

The research process is shown in section 6.5.

9.6. Data processing

The data collected in this study were statistically analyzed with SPSS28.0 software and Process plug-in. The current study will use the mediating effect test method proposed by Wen

and Ye (2014), with the specific process shown in Figure27. The Bootstrap method has a sample size of 5000, with a 95% confidence interval.

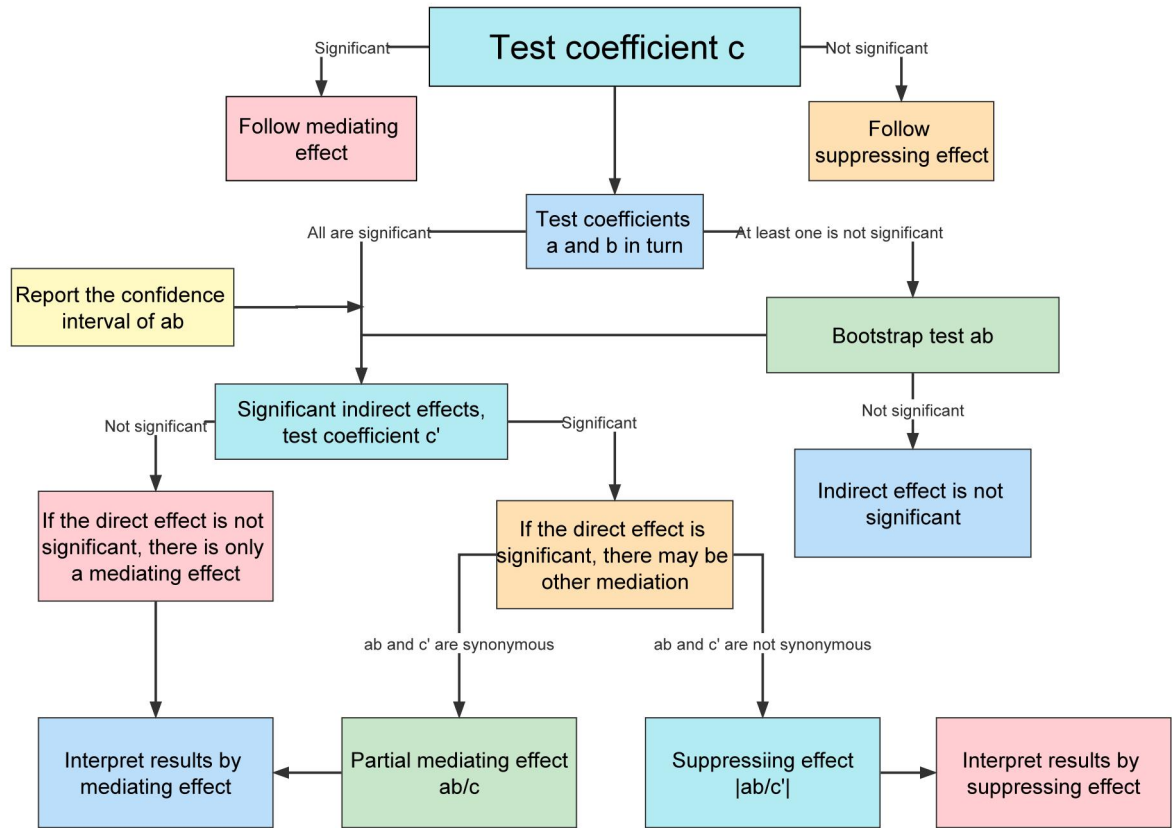

Figure27 Mediating effect test process

Note: This figure is from Wen and Ye (2014), and the researcher of the current study have translated it into English and presented it here.

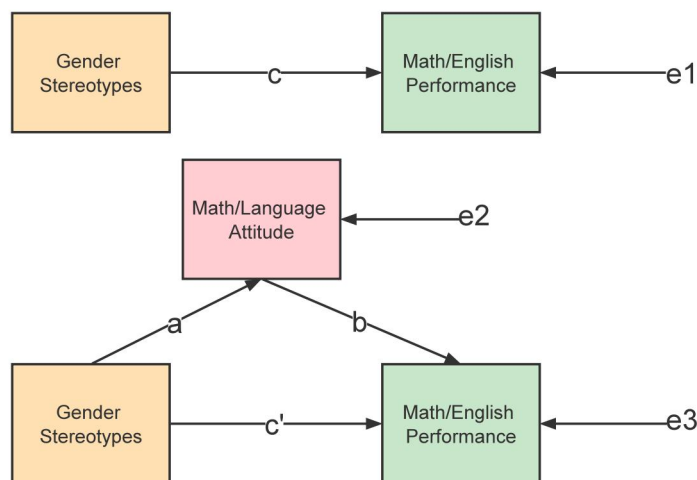

Figure28 Mediating effect model

According to the research hypothesis and data conditions, the current study mainly carries out the test of mediating effect as shown in Figure28. In the figure, c =total effect, c' =direct effect, ab =indirect effect.

9.7. Results

The current study focuses on whether math/language attitudes mediate between gender stereotypes and math/English performance. Therefore, explicit math gender stereotypes, explicit language gender stereotypes, and implicit math/language gender stereotypes are used as independent variables, with math and English scores as dependent variables, and explicit math attitudes, explicit language attitudes, and implicit math/language attitudes as mediating variables. Mediating effect models are established respectively, and then tested.

9.7.1. The mediating role of explicit math attitudes between explicit math gender stereotypes and math/English performance of the CSGS college students

9.7.1.1. The mediating role of explicit math attitudes between explicit math gender stereotypes and math performance of the CSGS college students

To investigate whether explicit math attitudes play a mediating role between explicit math gender stereotypes and math performance, the established mediating model was tested using sequential regression and Bootstrap techniques. The results are shown in Table76, Table77 and Figure29.

Table76 Three regression models for mediating effect of EMA

	Dependent variable	Independent variable	B	β	t	R-sq	F
Model 1	MP	EMGS	-.386	-.184	-2.016*	.034	4.063*
Model 2	EMA	EMGS	.308	.280	2.969**	.071	8.816*
Model 3	MP	EMGS	-.234	-.112	-1.219	.103	6.565**
		EMA	-.492	-.272	-2.966**		

Note: *= $P < .05$; **= $P < .01$.

Table77 Bootstrap results of mediating effect of EMA

	Effect	LLCI	ULCI	%
Total effect	-.386	-.765	-.007	
Direct effect	-.234	-.615	.146	61%
Indirect effect	-.151	-.317	-.042	39%

According to Table76, in Model 1, the independent variable EMGS($t=-2.016$) has a significant impact on the dependent variable MP, indicating a significant total effect (c is significant). In Model 2, the independent variable EMGS($t=2.969$) has a significant impact on the mediating variable EMA (a is significant). In Model 3, the independent variable EMGS($t=-1.219$) has no significant impact on the dependent variable MP (c' is not significant), while the mediating variable EMA($t=-2.966$) has a significant impact on the dependent variable MP (b is significant).

The mediating effect of EMA is tested using the Bootstrap technique. From Table77, it can be seen that the indirect effect value is $-.151$, and the 95% confidence interval is $[-.317, -.042]$, excluding 0 (ab is significant). Therefore, it indicates that the indirect effect is valid, and EMA plays a significant mediating role in the model. The 95% confidence interval for direct effects contains 0, indicating that the direct effect is not valid. By calculations, the indirect effect of EMA accounts for 39%. Furthermore, there is only a mediating effect.

Overall, explicit math attitudes play a mediating role in the impact of explicit math gender stereotypes on math performance, and are the only mediating variable. Thus, H17 has been confirmed.

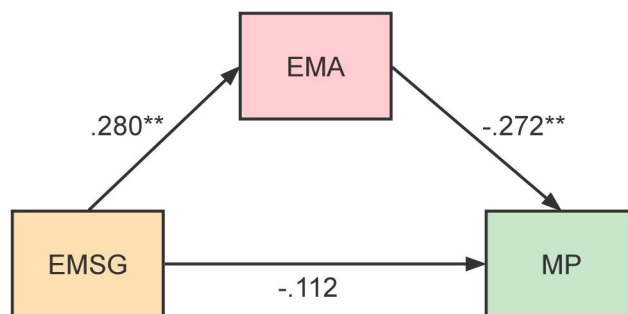

Figure29 The mediating effect model of EMSG, EMA and MP

9.7.1.2. The mediating role of explicit language attitudes between explicit language gender stereotypes and English performance of the CSGS college students

To investigate whether explicit language attitudes play a mediating role between explicit language gender stereotypes and English performance, the established mediating model was tested using sequential regression and Bootstrap techniques. The results are shown in Table78 and Table79.

Table78 Three regression models for mediating effect of ELA

	Dependent variable	Independent variable	B	β	t	R-sq	F
Model 1	EP	ELGS	-.066	-.039	-.418	.002	.175
Model 2	ELA	ELGS	.109	.127	1.378	.016	1.898
Model 3	EP	ELGS	-.043	-.026	-.275	.012	.698
		ELA	-.203	-.103	-1.105		

Table79 Bootstrap results of mediating effect of ELA

	Effect	LLCI	ULCI	%
Total effect	-.066	-.376	.245	
Direct effect	-.043	-.356	.269	×
Indirect effect	-.022	-.120	.020	×

According to Table78, in Model 1, the independent variable ELGS($t=-.418$) does not have a significant impact on the dependent variable EP, indicating no significant total effect (c is not significant). In Model 2, the independent variable ELGS($t=1.378$) does not have a significant impact on the mediating variable ELA (a is not significant). In Model 3, the independent variable ELGS($t=-.275$) has no significant impact on the dependent variable EP (c' is not significant), while the mediating variable ELA($t=-1.105$) has no significant impact on the

dependent variable EP (b is not significant).

The mediating effect of ELA is tested using the Bootstrap technique. From Table79, it can be seen that the indirect effect value is -.022, and the 95% confidence interval is [-.120, .020], including 0(ab is not significant). Therefore, it indicates that the indirect effect is invalid, and ELA does not play a mediating role in the model.

9.7.2. The mediating role of implicit math/language attitudes between implicit math/language gender stereotypes and math/English performance of the CSGS college students

9.7.2.1. The mediating role of implicit math/language attitudes between implicit math/language gender stereotypes and math performance of the CSGS college students

To investigate whether implicit math/language attitudes play a mediating role between implicit math/language gender stereotypes and math performance, the established mediating model was tested using sequential regression and Bootstrap techniques. The results are shown in Table80.

Table80 Three regression models for mediating effect of IAT4

	Dependent variable	Independent variable	B	β	t	R-sq	F
Model 1	MP	IAT3	-3.621	-.118	-1.113	.014	1.240
Model 2	IAT4	IAT3	.388	.561	6.352***	.314	40.345***
Model 3	MP	IAT3	1.297	.042	.338	.070	3.263*
		IAT4	-12.679	-.286	-2.286*		

Note: *= P<.05; ***=P<.001.

According to Table80, in Model 1, the independent variable IAT3(t=-1.113) does not have a significant impact on the dependent variable MP, indicating no significant total effect (c is not significant). In Model 2, the independent variable IAT3(t=6.352) has a significant impact on the mediating variable IAT4(a is significant). In Model 3, the independent variable IAT3(t=.338) has no significant impact on the dependent variable MP (c' is not significant),

while the mediating variable IAT4($t=-2.286$) has significant impact on the dependent variable MP (b is significant).

The coefficient c is not significant, indicating that the impact of implicit math/language gender stereotypes on math performance is not significant. The coefficients a and b are significant, indicating that implicit math/language gender stereotypes have a significant effect on implicit math/language attitudes, and that implicit math/language attitudes have a significant effect on math performance. The non-significance of c' means that the direct effect of implicit math/language gender stereotypes on math performance is not significant when controlling for implicit math/language attitudes. As both coefficients c and c' are not significant, but a and b are significant, and the sign of the indirect effect represented by ab is opposite to that of the direct effect represented by c', with one being positive and the other being negative, it suggests the possibility of a suppression effect(Liu et al., 2021). The suppression effect means that the reason why the impact of implicit math/language gender stereotypes on math performance is not significant is precisely because implicit math/language attitudes play a suppression role.

A bootstrap test is conducted on the suppression effect coefficient ab, and the results are shown in Table81. In this method, if the 95% confidence interval includes 0, then ab is not significant; otherwise, it is significant. The results show that $ab=-4.918$, 95% CI = [-10.395, 1.036], indicating that the suppression effect is not significant.

Table81 Boostrap results of mediating effect of IAT4

	Effect	LLCI	ULCI	%
Total effect	-3.621	-10.083	2.842	
Direct effect	1.297	-6.328	8.922	×
Indirect effect	-4.918	-10.395	1.036	×

9.7.2.2. The mediating role of implicit math/language attitudes between implicit math/language gender stereotypes and English performance of the CSGS college students

To investigate whether implicit math/language attitudes play a mediating role between implicit

math/language gender stereotypes and English performance, the established mediating model was tested using sequential regression and Bootstrap techniques. The results are shown in Table82.

Table82 Three regression models for mediating effect of IAT4

	Dependent variable	Independent variable	B	β	t	R-sq	F
Model 1	EP	IAT3	1.169	.040	.374	.002	.140
Model 2	IAT4	IAT3	.389	.564	6.412***	.318	41.114***
Model 3	EP	IAT3	2.230	.076	.587	.004	.192
		IAT4	-2.725	-.064	-.495		

Note: ***=P<.001.

According to Table82, in Model 1, the independent variable IAT3(t=.374) does not have a significant impact on the dependent variable EP, indicating no significant total effect (c is not significant). In Model 2, the independent variable IAT3(t=6.412) has a significant impact on the mediating variable IAT4(a is significant). In Model 3, the independent variable IAT3(t=.587) has no significant impact on the dependent variable EP (c' is not significant), while the mediating variable IAT4(t=-.495) does not have significant impact on the dependent variable EP (b is not significant).

A bootstrap test is conducted on the mediating effect coefficient ab, and the results are shown in Table83. In this method, if the 95% confidence interval includes 0, then ab is not significant; otherwise, it is significant. The results show that ab=-1.061, 95% CI = [-5.096, 2.808], indicating that the mediating effect is not significant.

Table83 Bootstrap results of mediating effect of IAT4

	Effect	LLCI	ULCI	%
Total effect	1.169	-5.040	7.378	
Direct effect	2.230	-5.324	9.784	×
Indirect effect	-1.061	-5.096	2.808	×

9.7.3. The mediating role of explicit math attitudes between implicit trait gender stereotypes and math/English performance of the CSGS college students

9.7.3.1. The mediating role of explicit math attitudes between implicit trait gender stereotypes and math performance of the CSGS college students

To investigate whether explicit math attitudes play a mediating role between implicit trait gender stereotypes and math performance, the established mediating model was tested using sequential regression and Bootstrap techniques. The results are shown in Table84, Table85 and Figure30.

Table84 Three regression models for mediating effect of IAT1

	Dependent variable	Independent variable	B	β	t	R-sq	F
Model 1	MP	IAT1	-8.778	-.242	-2.380*	.059	5.662*
Model 2	EMA	IAT1	5.683	.278	2.759**	.077	7.612**
Model 3	MP	IAT1	-6.601	-.182	-1.750	.102	5.092**
		EMA	-.383	-.216	-2.077*		

Note: *= P<.05; **=P<.01.

Table85 Bootstrap results of mediating effect of IAT1

	Effect	LLCI	ULCI	%
Total effect	-8.778	-16.106	-1.451	
Direct effect	-6.601	-14.095	.893	75%
Indirect effect	-2.177	-7.003	-.225	25%

According to Table84, in Model 1, the independent variable IAT1($t=-2.830$) has a significant impact on the dependent variable MP, indicating a significant total effect (c is significant). In Model 2, the independent variable IAT1($t=2.759$) has a significant impact on the mediating

variable EMA (a is significant). In Model 3, the independent variable IAT1($t=-1.750$) has no significant impact on the dependent variable MP (c' is not significant), while the mediating variable EMA($t=-2.077$) has a significant impact on the dependent variable MP (b is significant).

The mediating effect of EMA is tested using the Bootstrap technique. From Table85 , it can be seen that the indirect effect value is -2.177 , and the 95% confidence interval is $[-7.003, -.225]$, excluding 0(ab is significant). Therefore, it indicates that the indirect effect is valid, and EMA plays a significant mediating role in the model. The 95% confidence interval for direct effects $[-14.095, .893]$ contains 0, indicating that the direct effect is not valid. By calculations, the indirect effect of EMA accounts for 25%. Furthermore, there is only a mediating effect.

Overall, explicit math attitudes play a mediating role in the impact of implicit trait gender stereotypes on math performance, and are the only mediating variable. Thus, H17 has been confirmed again.

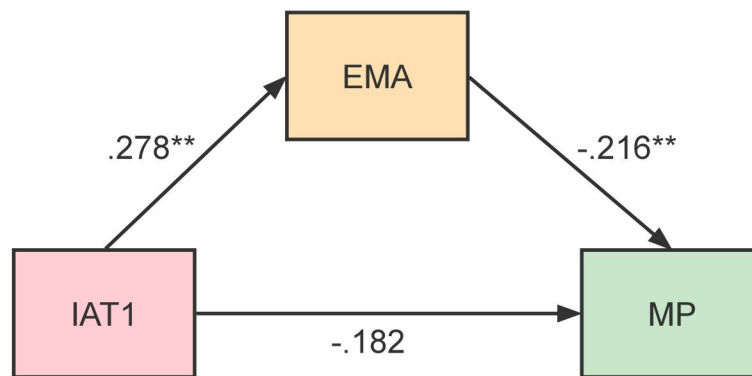

Figure30 The mediating effect model of IAT1, EMA and MP

9.7.3.2. The mediating role of explicit language attitudes between implicit trait gender stereotypes and English performance of the CSGS college students

To investigate whether explicit language attitudes play a mediating role between explicit language gender stereotypes and English performance, the established mediating model was tested using sequential regression and Bootstrap techniques. The results are shown in Table86 and Table87.

Table86 Three regression models for mediating effect of ELA

	Dependent variable	Independent variable	B	β	t	R-sq	F
Model 1	EP	IAT1	1.271	.037	.351	.001	.123
Model 2	ELA	IAT1	3.225	.182	1.767	.033	3.121
Model 3	EP	IAT1	1.982	.057	.538	.014	.624
		ELA	-.220	-.113	-1.060		

Table87 Bootstrap results of mediating effect of ELA

	Effect	LLCI	ULCI	%
Total effect	1.271	-5.925	8.466	
Direct effect	1.982	-5.332	9.296	×
Indirect effect	-.711	-3.224	.764	×

According to Table86, in Model 1, the independent variable IAT1($t=.351$) does not have a significant impact on the dependent variable EP, indicating no significant total effect (c is not significant). In Model 2, the independent variable IAT1($t=1.767$) does not have a significant impact on the mediating variable ELA (a is not significant). In Model 3, the independent variable IAT1($t=.538$) has no significant impact on the dependent variable EP (c' is not significant), while the mediating variable ELA($t=-1.060$) has no significant impact on the dependent variable EP (b is not significant). The mediating effect of ELA is tested using the Bootstrap technique. From Table87, it can be seen that the indirect effect value is $-.711$, and the 95% confidence interval is $[-3.224, .764]$, including 0 (ab is not significant). Therefore, it indicates that the indirect effect is invalid, and ELA does not play a mediating role in the model.

9.8. Discussion

The mechanism through which gender stereotypes can affect math/language performance is a

key concern of this study. The study proposes a hypothetical path in which gender stereotypes affect math/language performance through their influence on math/language attitudes, with math/language attitudes potentially serving as a mediator. The study conducted measurements of gender stereotypes using both explicit and implicit methods, with content covering trait gender stereotypes, subject gender stereotypes, and math/language gender stereotypes. Math/language attitudes were also measured using both explicit and implicit methods, while math/language performance is represented by participants' math and English scores on college entrance exams. The wide range of measurement methods and content provided ample room for model construction. However, unfortunately, the current research results show that only partial mediating models can be established between some variables, and most of the remaining mediating models cannot be established.

Currently, the two established mediating models are EMSG-EMA-MP and IAT1-EMA-MP, indicating that for CSGS college students, their explicit math attitude plays a mediating role between explicit math gender stereotype and math performance, as well as between implicit trait gender stereotype and math performance. Thus, H17 has been confirmed. The results of this study are inconsistent with some previous studies. Xie et al. (2022) found that for both male and female college students, the mediating effect of explicit math attitude between explicit math gender stereotypes and math performance did not exist. However, this study found that for CSGS college students, not only does explicit math attitude mediate between explicit math gender stereotypes and math grades, it also mediates between implicit trait gender stereotypes and math performance. Of course, the difference in results may be due to different participants. After all, this study focused on CSGS college students only. However, other combinations of gender stereotype variables and math/language attitude variables could not construct a mediating model with math performance as the independent variable.

Unfortunately, this study did not successfully establish any mediating model with English performance as the dependent variable. This seems to be a confusing issue. Just like math performance, English performance are also based on college entrance exams, and English is a typical language subject and a compulsory course for every Chinese student. However, in this study, it was found that none of the gender stereotype variables or math/language attitude variables could establish a mediating model with English scores. H18 has been confirmed.

Perhaps, the mechanisms underlying this finding need further research.

9.9. Conclusion

- a) Explicit math attitudes play a mediating role between explicit math gender stereotypes and math performance, H17 has been confirmed.
- b) Explicit math attitudes play a mediating role between implicit trait gender stereotypes and math performance, H17 has been confirmed again.
- c) No mediating model has been established with English performance as the dependent variable, indicating that math/language attitudes do not mediate between gender stereotypes and English performance. H18 has not been confirmed.

10. General Discussion

In the general discussion section, it is necessary to return to the initial research questions and clarify what kind of answers the current studies provide to those questions. The following are the answers that current studies provide to the research questions, but it is not limited to them. It also discusses some more general issues. Additionally, it should be noted that the many following discussion is limited to CSGS college students and cannot be extrapolated to other populations.

10.1. Are CSGS college students really the exception?

An important question for the current studies is whether CSGS college students have particular gender stereotypes compared to SGS college students, given that they have chosen a major that is diametrically opposed to the subject gender stereotype? Or, do CSGS college students identify less with traditional gender stereotypes than SGS college students? Are they really the exception? The researcher was expecting the answer to this question. Thus, in current studies, both explicit and implicit gender stereotypes were measured using both direct and indirect measures, in which explicit trait gender stereotypes, explicit subject gender stereotypes, explicit math gender stereotypes, and explicit language gender stereotypes were measured directly, and implicit trait stereotypes, implicit subject gender stereotypes, and implicit math/language gender stereotypes were measured indirectly. Comparisons were also made between CSGS college students and SGS college students. The results of the studies showed that there were no significant differences between CSGS and SGS college students in all of the explicit or implicit gender stereotypes except for the explicit subject gender stereotypes. Even CSGS college students did not agree with sex egalitarianism more than SGS college students. Only one of the eight measures showed differences, thus the current evidence is difficult to support the fundamental differences in gender stereotypes between CSGS and SGS college students, and is more inclined to believe that although there are some minor differences in gender stereotypes between CSGS and SGS college students, there is no overall difference. This means that, on the whole, CSGS college students are not different from SGS college students in terms of gender stereotypes and gender egalitarianism, and they are not an exception.

10.2. What is unique about CSGS college students?

CSGS college students do not show significant differences from SGS college students in terms of gender stereotypes, and thus did not break gender stereotypes as expected in this study. So where does the uniqueness of CSGS college students lie? In addition to gender stereotypes, this study also examined the mathematics and language attitudes of CSGS college students. The results showed that CSGS college students differ significantly from SGS college students in their explicit math and language attitudes, being more positive towards both. This suggests that CSGS college students have their own unique characteristics. However, there were no differences between CSGS and SGS college students in their implicit attitudes towards math and language, both of which were more negative towards math but more positive towards language. This once again demonstrates that implicit and explicit attitudes are indeed two different constructs.

10.3. Which factor is more important in influencing gender stereotypes?

Since CSGS college students are not the exception, it means that choosing a major that is completely different from subject gender stereotypes is not a very important factor that can affect gender stereotypes. Which factor is really important? Therefore, the current studies analyzed the impact of gender, major, and residence on all explicit and implicit gender stereotypes. The results show that all three factors may have an impact on explicit and implicit gender stereotypes. The main effect of gender is significant in five variables: explicit subject gender stereotypes, explicit math gender stereotypes, explicit language gender stereotypes, and implicit trait gender stereotypes, as well as sex role egalitarianism. In terms of explicit math gender stereotypes and explicit language gender stereotypes, both major and residence have significant main effects. Based on existing evidence, it is difficult for the current studies not to conclude that gender is the most influential factor on gender stereotypes. In general, female college students are more supportive of sex role egalitarianism, and they are less likely to endorse subject gender stereotypes, math gender stereotypes, language gender stereotypes explicitly, and trait gender stereotypes implicitly. Compared to male college students, female college students show a stronger desire for gender equality and a strong resistance to gender stereotypes. A reality in society is that women have long been in a disadvantaged position compared to men, and even now, this disadvantaged position has not fundamentally changed. Even based on interest considerations, women in disadvantaged positions naturally desire

gender equality and are more resistant to existing gender stereotypes. While men are vested interests in society, maintaining traditional gender roles and stereotypes may be more beneficial for them. Therefore, women are more likely to disagree with gender stereotypes, which is also reflected in the current studies.

10.4. Who are the most revolutionary college students in the gender field?

In the current studies, participants were divided into four groups: liberal male, liberal female, science male students, and science female, and their gender stereotypes and math/language attitudes were compared across variables. The results revealed that science female showed a consistent preference across several variables. Among the four groups, science female had the strongest support for sex role egalitarianism, but the least agreement with explicit subject gender stereotypes and explicit math gender stereotypes. Additionally, they were only surpassed by liberal female in their disagreement with explicit language gender stereotypes and implicit trait gender stereotypes. They also displayed the most positive attitudes towards math and language in their explicit attitudes. Based on this evidence, the current studies conclude that science female college students display a significant degree of dissent towards gender stereotypes and a desire for gender role equality, making them the most revolutionary student group in the gender field.

10.5. What is the relationship between explicit gender stereotypes and implicit gender stereotypes?

The relationship between directly measured explicit gender stereotypes and indirectly measured implicit gender stereotypes has been a focus of academic research, but there have been inconsistent findings. In the current studies, multiple methods including correlation analysis, exploratory factor analysis, and confirmatory factor analysis were used to explore the relationship between the two. The results of correlation analysis showed that the correlation between explicit and implicit gender stereotypes was low and mostly negative. The results of exploratory factor analysis revealed that implicit gender stereotypes and explicit gender stereotypes were each associated with different factors. Furthermore, the results of confirmatory factor analysis showed that a model in which the variables of implicit gender stereotypes were listed as a separate factor was superior to a model in which explicit and implicit gender stereotypes were combined into one factor. Taken together, these findings

provide strong evidence for the notion that implicit gender stereotypes are a related yet distinct construct from explicit gender stereotypes.

Actually, the independence of explicit and implicit gender stereotypes was also reflected in two aspects. First, the experimental dissociation of explicit and implicit gender stereotypes was observed. On explicit gender stereotypes, all college students showed a lack of explicit recognition of gender stereotypes. However, on implicit gender stereotypes, all college students demonstrated implicit recognition of gender stereotypes. Second, while gender, major, and place of residence had significant effects on explicit gender stereotypes, differences based on these factors disappeared in implicit gender stereotypes, except for sex differences in implicit trait gender stereotypes. College students implicitly shared consistent gender stereotypes in general.

In conclusion, there is sufficient evidence to support the notion that explicit and implicit gender stereotypes are related yet independent constructs.

10.6. What is the predictive power of gender stereotypes on math/language attitudes?

Based on the correlation matrix, it can be seen that there are significant correlations between the variables of explicit and implicit gender stereotypes and explicit math attitudes, explicit language attitudes, as well as implicit math/language attitudes, although the correlation coefficients are not high. Furthermore, the current studies employed a stepwise regression analysis to explore which explicit and implicit gender stereotype variables could predict math and language attitude. The results showed that explicit math gender stereotypes, implicit trait gender stereotypes, and implicit math/language gender stereotypes significantly predicted explicit math attitudes, while explicit math gender stereotypes also significantly predicted explicit language attitudes. Explicit science male gender stereotypes and implicit trait gender stereotypes significantly predicted implicit math/language attitudes. Based on this evidence, the current studies have to conclude that gender stereotypes can indeed predict attitudes towards math/language, and have a certain predictive ability.

10.7. What is the predictive power of gender stereotypes on math/English performance?

Based on the correlation matrix, it can be seen that for CSGS college students, except for the significant correlation between explicit math gender stereotypes, implicit trait gender stereotypes, and math scores, the correlation between other gender stereotype variables and

math/English scores is not significant. In the regression model established using the stepwise regression method, two variables can predict math performance of CSGS college students, one is the implicit trait gender stereotype, and the other is the explicit language gender stereotype. There were no variables that successfully entered the regression model for predicting English performance of CSGS college students. Based on this evidence, the current studies believe that gender stereotypes have a certain predictive power for the math performance of CSGS college students, but currently do not support effective prediction for English performance. However, this conclusion does not apply to male and female college students.

10.8. Does the mediating effect of math/language attitudes hold true?

The current studies did establish a mediating model with some gender stereotypes as independent variables, math/English performance as dependent variables, and math/language attitudes as mediating variables. However, more mediating models were established unsuccessfully. Based on this evidence, it can be considered that math/language attitudes may indeed be the mediating variables between gender stereotypes and math/English performance, but this possibility is not very high. This suggests that the relationship between gender stereotypes, math/language attitudes, and math/English performance may still need further research. Considering the low correlation between gender stereotypes and math/language performance, it may be worthwhile to investigate whether there are suppression effects of certain variables.

11. General Conclusion

- a) Apart from explicit subject gender stereotypes, there were no differences in other explicit or implicit gender stereotypes between CSGS and SGS college students. Notably, CSGS college students did not demonstrate greater identification with sex role egalitarianism compared to SGS college students. Overall, CSGS college students are not exceptional in terms of gender stereotypes and sex role egalitarianism compared to SGS college students, as there is more similarity than difference between the two groups.
- b) CSGS college students do exhibit differences from SGS college students with regard to their explicit attitudes towards math and language. Specifically, CSGS students hold more positive attitudes towards both math and language in comparison to SGS students. However, there were no notable differences in implicit attitudes towards math and

language between the two groups, as both shared negative implicit attitudes towards math and positive implicit attitudes towards language.

- c) Gender is a significant factor that influences gender stereotypes. Compared to male college students, female college students are less accepting of gender stereotypes and more accepting of sex role egalitarianism, although this difference is mainly manifested in explicit rather than implicit measurements.
- d) Explicit gender stereotypes and implicit gender stereotypes are linked yet distinct constructs.
- e) Gender stereotypes can indeed predict math/language attitude, and have a certain predictive ability.
- f) Gender stereotypes have a certain predictive power for the math performance of CSGS college students, but not for their English performance.
- g) Math/language attitudes may indeed be the mediating variables between gender stereotypes and math/English performance, but this possibility is not very high.

References

- Alan, S., Ertac, S., & Mumcu, I. (2018). Gender stereotypes in the classroom and effects on achievement. *Review of Economics and Statistics*, 100(5), 876-890. https://doi.org/10.1162/rest_a_00756
- Anderson, S. J., & Johnson, J. T. (2003). The who and when of “gender-blind” attitudes: Predictors of gender-role egalitarianism in two different domains. *Sex Roles*, 49, 527-532. <https://doi.org/10.1007/BF00287485>
- Becirovic, S. (2017). The Relationship between Gender, Motivation and Achievement in Learning English as a Foreign Language. *European Journal of Contemporary Education*, 6(2), 210-220. <https://doi.org/10.13187/ejced.2017.2.210>
- Bedyńska, S., Krejtz, I., & Sedek, G. (2018). Chronic stereotype threat is associated with mathematical achievement on representative sample of secondary schoolgirls: The role of gender identification, working memory, and intellectual helplessness. *Frontiers in psychology*, 9, 428. <https://doi.org/10.3389/fpsyg.2018.00428>
- Beere, C. A., King, D. W., Beere, D. B., & King, L. A. (1984). The Sex-Role Egalitarianism Scale: A measure of attitudes toward equality between the sexes. *Sex Roles*, 10, 563-576. <https://doi.org/10.1007/BF00287265>
- Bergen, D. J., & Williams, J. E. (1991). Sex stereotypes in the United States revisited: 1972–1988. *Sex Roles*, 24(7), 413-423. <https://doi.org/10.1007/BF00289331>
- Berkel, L. A. (2004). A psychometric evaluation of the sex-role egalitarianism scale with African Americans. *Sex Roles*, 50, 737-742. <https://doi.org/10.1023/B:SERS.0000027836.51374.a3>
- Bosson, J. K., Swann Jr, W. B., & Pennebaker, J. W. (2000). Stalking the perfect measure of implicit self-esteem: The blind men and the elephant revisited? *Journal of Personality and Social Psychology*, 79(4), 631-643. <https://doi.org/10.1037/0022-3514.79.4.631>
- Broverman, I. K., Vogel, S. R., Broverman, D. M., Clarkson, F. E., & Rosenkrantz, P. S. (1972). Sex - role stereotypes: a current appraisal *Journal of social issues*, 28(2), 59-78. <https://doi.org/10.1111/j.1540-4560.1972.tb00018.x>
- Brozo, W. G., Sulkunen, S., Shiel, G., Garbe, C., Pandian, A., & Valtin, R. (2014). Reading, gender, and engagement: Lessons from five PISA countries. *Journal of Adolescent & Adult Literacy*, 57(7), 584-593. <https://doi.org/10.1002/jaal.291>
- Buchner, A., & Wippich, W. (2000). On the reliability of implicit and explicit memory measures. *Cognitive psychology*, 40(3), 227-259. <https://doi.org/10.1006/cogp.1999.0731>
- Burgess, D., & Borgida, E. (1999). Who women are, who women should be: Descriptive and prescriptive gender stereotyping in sex discrimination. *Psychology, Public Policy, and Law*, 5(3), 665-692. <https://doi.org/10.1037/1076-8971.5.3.665>
- Cai, H. (2003). A review on implicit association test. *Advances in Psychological Science*(03), 339-344.
- Cai, H., Zhou, Y., & Shi, Q. (2001). Implicit Association Test (IAT) and its application in the study of gender stereotypes. *Social Psychological Research*(4), 6-11.
- Castañó, A. M., Fontanil, Y., & García-Izquierdo, A. L. (2019). “Why can’t I become a manager?”—A systematic review of gender stereotypes and organizational discrimination. *International journal of environmental research and public health*, 16(10), 1813. <https://doi.org/10.3390/ijerph16101813>
- Chaffee, K. E., Lou, N. M., & Noels, K. A. (2020). Does stereotype threat affect men in language domains? *Frontiers in psychology*, 11, 1302. <https://doi.org/10.3389/fpsyg.2020.01302>
- Chaffee, K. E., Lou, N. M., Noels, K. A., & Katz, J. W. (2020). Why don’t “real men” learn languages? Masculinity threat and gender ideology suppress men’s language learning motivation. *Group Processes & Intergroup Relations*, 23(2), 301-318. <https://doi.org/10.1177/1368430219835025>

- Charlesworth, T. E., & Banaji, M. R. (2022). Patterns of implicit and explicit stereotypes III: Long-term change in gender stereotypes. *Social Psychological and Personality Science*, 13(1), 14-26. <https://doi.org/10.1177/1948550620988425>
- Chee, K. H., Pino, N. W., & Smith, W. L. (2005). Gender differences in the academic ethic and academic achievement. *College student journal*, 39(3), 604-619.
- Contini, D., Di Tommaso, M. L., & Mendolia, S. (2017). The gender gap in mathematics achievement: Evidence from Italian data. *Economics of Education Review*, 58, 32-42. <https://doi.org/10.1016/j.econedurev.2017.03.001>
- Cvencek, D., Brečić, R., Gacesa, D., & Meltzoff, A. N. (2021). Development of math attitudes and math self - concepts: Gender differences, implicit–explicit dissociations, and relations to math achievement. *Child Development*, 92(5), 940-956. <https://doi.org/10.1111/cdev.13523>
- De Gaer, E. V., Pustjens, H., Damme, J. V., & Munter, A. D. (2007). Impact of attitudes of peers on language achievement: Gender differences. *The journal of educational research*, 101(2), 78-90. <https://doi.org/10.3200/JOER.101.2.78-93>
- De Houwer, J., Teige-Mocigemba, S., Spruyt, A., & Moors, A. (2009). Implicit measures: A normative analysis and review. *Psychological bulletin*, 135(3), 347-368. <https://doi.org/10.1037/a0014211>
- Deaux, K., & Lewis, L. L. (1983). Assessment of gender stereotypes: Methodology and components. *Psychological Documents*, 13, 1-23.
- Deaux, K., & Lewis, L. L. (1984). Structure of gender stereotypes: Interrelationships among components and gender label. *Journal of Personality and Social Psychology*, 46(5), 991-1004.
- Deng, I. (2009). A Probe into Chinese Traditional Confucian Responsibility Ethics Thoughts. *Journal of Qinghai Normal University(Philosophy and Social Sciences Edition)*, 137(06), 37-40. <https://doi.org/10.16229/j.cnki.issn1000-5102.2009.06.020>
- Deng, Z. (2016). *Experimental psychology*. Beijing Normal University Publishing Group.
- Durik, A. M., Vida, M., & Eccles, J. S. (2006). Task values and ability beliefs as predictors of high school literacy choices: a developmental analysis. *Journal of Educational Psychology*, 98(2), 382. <https://doi.org/10.1037/0022-0663.98.2.382>
- Eagly, A. H. (2013). *Sex differences in social behavior: A social-role interpretation*. Psychology Press.
- Else-Quest, N. M., Hyde, J. S., & Linn, M. C. (2010). Cross-national patterns of gender differences in mathematics: a meta-analysis. *Psychological bulletin*, 136(1), 103-127. <https://doi.org/10.1037/a0018053>
- Encyclopedia Britannica*. <https://www.britannica.com/>
- Experimental dissociation. In. (2003). *A Concise Dictionary of Psychology*.
- Fazio, R. H., & Olson, M. A. (2003). Implicit measures in social cognition research: Their meaning and use. *Annual Review of Psychology*, 54(1), 297-327. <https://doi.org/10.1146/annurev.psych.54.101601.145225>
- Fennema, E., & Sherman, J. A. (1976). Fennema-Sherman mathematics attitudes scales: Instruments designed to measure attitudes toward the learning of mathematics by females and males. *Journal for research in Mathematics Education*, 7(5), 324-326. <https://doi.org/10.5951/jresmetheduc.7.5.0324>
- Finnegan, E., Oakhill, J., & Garnham, A. (2015). Counter-stereotypical pictures as a strategy for overcoming spontaneous gender stereotypes. *Frontiers in psychology*, 6, 1291. <https://doi.org/10.3389/fpsyg.2015.01291>
- Fiske, S. T., Cuddy, A. J., Glick, P., & Xu, J. (2002). A model of (often mixed) stereotype content: Competence and warmth respectively follow from perceived status and competition. *Journal of Personality and Social Psychology*, 82(6), 878-902. <https://doi.org/10.1037//0022-3514.82.6.878>
- Fiske, S. T., Xu, J., Cuddy, A. C., & Glick, P. (1999). (Dis) respecting versus (dis) liking: Status and

- interdependence predict ambivalent stereotypes of competence and warmth. *Journal of social issues*, 55(3), 473-489. <https://doi.org/10.1111/0022-4537.00128>
- Good, J. J., Woodzicka, J. A., & Wingfield, L. C. (2010). The effects of gender stereotypic and counter-stereotypic textbook images on science performance. *The Journal of social psychology*, 150(2), 132-147. <https://doi.org/10.1080/00224540903366552>
- Greenwald, A. G. (1990). What cognitive representations underlie social attitudes? *Bulletin of the Psychonomic Society* 28(3), 254-260. <https://doi.org/10.3758/BF03334018>
- Greenwald, A. G., & Banaji, M. R. (1995). Implicit social cognition: attitudes, self-esteem, and stereotypes. *Psychological Review*, 102(1), 4-27. <https://doi.org/10.1037/0033-295x.102.1.4>
- Greenwald, A. G., & Banaji, M. R. (2017). The implicit revolution: Reconceiving the relation between conscious and unconscious. *American Psychologist*, 72(9), 861-871. <https://doi.org/10.1037/amp0000238>
- Greenwald, A. G., Brendl, M., Cai, H., Cvencek, D., Dovidio, J. F., Friese, M., Hahn, A., Hehman, E., Hofmann, W., & Hughes, S. (2022). Best research practices for using the Implicit Association Test. *Behavior research methods*(54), 1161-1180. <https://doi.org/https://doi.org/10.3758/s13428-021-01624-3>
- Greenwald, A. G., & Lai, C. K. (2020). Implicit social cognition. *Annual Review of Psychology*, 71(1), 419-445. <https://doi.org/10.1146/annurev-psych-010419-050837>
- Greenwald, A. G., McGhee, D. E., & Schwartz, J. L. (1998). Measuring individual differences in implicit cognition: the implicit association test. *Journal of Personality and Social Psychology*, 74(6), 1464. <https://doi.org/10.1037/0022-3514.74.6.1464>
- Greenwald, A. G., Nosek, B. A., & Banaji, M. R. (2003). Understanding and using the implicit association test: I. An improved scoring algorithm. *Journal of Personality and Social Psychology*, 85(2), 197-216. <https://doi.org/10.1037/0022-3514.85.2.197>
- Guimond, S., & Roussel, L. (2001). Bragging about one's school grades: gender stereotyping and students' perception of their abilities in science, mathematics, and language. *Social Psychology of Education*, 4, 275-293. <https://doi.org/10.1023/A:1011332704215>
- Haines, E. L., Deaux, K., & Lofaro, N. (2016). The times they are a-changing... or are they not? A comparison of gender stereotypes, 1983–2014. *Psychology of Women Quarterly*, 40(3), 353-363. <https://doi.org/10.1177/0361684316634081>
- Hastie, R. (1984). Causes and effects of causal attribution. *Journal of Personality and Social Psychology*, 46(1), 44. <https://doi.org/10.1037/0022-3514.46.1.44>
- He, Z., & Liu, J. (2007). The empirical research on processing model of gender- subject stereotypes. *Chinese Journal of Clinical Psychology*(06), 577-579. <https://doi.org/10.16128/j.cnki.1005-3611.2007.06.014>
- Heilman, M. E. (2012). Gender stereotypes and workplace bias. *Research in Organizational Behavior*, 32(1), 113-135. <https://doi.org/10.1016/j.riob.2012.11.003>
- Helmreich, R. L. (1982). On the distinction between sex-role attitudes and sex-linked traits and their stability. In P. W. Bermant & E. R. Ramrey (Eds.), *Women: a developmental perspective* (pp. 157-165). Bethesda, Md. : U.S. Dep of Health and Human Serv, Publ Health Serv, Natl Inst of Health.
- Hofmann, W., Gawronski, B., Gschwendner, T., Le, H., & Schmitt, M. (2005). A meta-analysis on the correlation between the Implicit Association Test and explicit self-report measures. *Personality and Social Psychology Bulletin*, 31(10), 1369-1385. <https://doi.org/10.1177/014616720527561>
- Hosoda, M., & Stone, D. L. (2000). Current gender stereotypes and their evaluative content. *Perceptual and motor skills*, 90, 1283-1294. <https://doi.org/10.2466/pms.2000.90.3c.1283>
- Houwer, J. D. (2001). A Structural and Process Analysis of the Implicit Association Test. *Journal of Experimental Social Psychology*, 37(6), 443-451. <https://doi.org/10.1006/jesp.2000.1464>
- Hu, Z. (2005). An implicit study on college students' occupation—sex stereotype. *Psychological Science*(05),

- 1122-1125. <https://doi.org/10.16719/j.cnki.1671-6981.2005.05.024>
- Hyde, J. S., Fennema, E., Ryan, M., Frost, L. A., & Hopp, C. (1990). Gender comparisons of mathematics attitudes and affect: A meta-analysis. *Psychology of Women Quarterly*, 14(3), 299-324. <https://doi.org/10.1111/j.1471-6402.1990.tb00022.x>
- Jacoby, L. L. (1991). A process dissociation framework: Separating automatic from intentional uses of memory. *Journal of memory and language*, 30(5), 513-541. [https://doi.org/10.1016/0749-596X\(91\)90025-F](https://doi.org/10.1016/0749-596X(91)90025-F)
- Jameson, M. M., Sexton, J. M., London, D. R., & Wenner, J. M. (2022). Math attitudes in undergraduate students enrolled in introductory geoscience courses. *Proceedings of the Improving Undergraduate STEM Education Summit, Washington, DC, USA*, 1-3.
- Jia, F. (2013). *A Research of Implicit and Explicit Gender Prejudice of College Students* [PHD, Soochow University].
- Katz, D., & Braly, K. W. (1933). Racial stereotypes of one hundred college students. *Journal of Abnormal & Social Psychology*, 28(3), 280-290. <https://doi.org/10.1037/h0074049>
- Katz, D., & Braly, K. W. (1935). Racial prejudice and racial stereotypes. *Journal of Abnormal & Social Psychology*, 30(2), 175-193. <https://doi.org/10.1037/h0059800>
- King, L. A., & King, D. W. (1990). Abbreviated measures of sex role egalitarian attitudes. *Sex Roles*, 23(11), 659-673. <https://doi.org/10.1007/BF00289254>
- King, L. A., & King, D. W. (1997). Sex-Role Egalitarianism Scale: Development, Psychometric Properties, and Recommendations for Future Research. *Psychology of Women Quarterly*, 21(1), 71-87. <https://doi.org/10.1111/j.1471-6402.1997.tb00101.x>
- Koenig, A. M. (2018). Comparing prescriptive and descriptive gender stereotypes about children, adults, and the elderly. *Frontiers in psychology*(9), 1068. <https://doi.org/10.3389/fpsyg.2018.01086>
- Lane, K. A., Banaji, M. R., Nosek, B. A., & Greenwald, A. G. (2007). Understanding and using the Implicit Association Test: IV: What we know (so far) about the method. In B. Wittenbrink & N. Schwarz (Eds.), *Implicit measures of attitudes* (pp. 59-102). The Guilford Press.
- Levine, S. C., & Pantoja, N. (2021). Development of children's math attitudes: Gender differences, key socializers, and intervention approaches. *Developmental Review*, 62, 100997. <https://doi.org/10.1016/j.dr.2021.100997>
- Li, F. (2016). A IAT study on the implicit subject gender stereotypes of college students. *Journal of Kaifeng Institute of Education*, 36(08), 181-183. <https://doi.org/10.3969/j.issn.1008-9640.2016.08.085>
- Li, F., & Jia, L. (2009). A study on implicit subject-gender stereotype of undergraduates by SEB. *Journal of Shanxi Normal University(Social Science Edition)*, 36(02), 120-123.
- Lin, S.-H., & Huang, Y.-C. (2016). Development and application of a Chinese version of the short attitudes toward mathematics inventory. *International Journal of Science and Mathematics Education*, 14, 193-216. <https://doi.org/10.1007/s10763-014-9563-8>
- Lippmann, W. (2010). *Public Opinion*. Wilder Publications.
- Liu, O. L., & Wilson, M. (2009). Gender differences in large-scale math assessments: PISA trend 2000 and 2003. *Applied Measurement in Education*, 22(2), 164-184. <https://doi.org/10.1080/08957340902754635>
- Liu, X. (2007). *The Psychological Structure and Development of Children's and Adolescents' Gender Stereotypes* [Master, Central China Normal University].
- Liu, X., & Zuo, B. (2006). *The Development of the Gender Stereotype Scale and the Research on the Structure of Teenagers' Gender Stereotypes* 2006 Academic Seminar of Chinese Association of Social Psychology, Anhui, China.
- Liu, Y. (2010). *Attribution Theory & Its Application*. Shanghai Educational Publishing House.
- Liu, Z., Liu, T., & Mu, S. (2021). Statistical analysis framework of suppression effect and its application.

- Psychology: Techniques and Applications*, 9(10), 610-618. <https://doi.org/10.16842/j.cnki.issn2095-5588.2021.10.004>
- Lueptow, L. B., Garovich, L., & Lueptow, M. B. (1995). The persistence of gender stereotypes in the face of changing sex roles: Evidence contrary to the sociocultural model. *Ethology and Sociobiology*, 16(6), 509-530. [https://doi.org/10.1016/0162-3095\(95\)00072-0](https://doi.org/10.1016/0162-3095(95)00072-0)
- Ma, F., & Liang, N. (2006). A study on implicit mathematics gender stereotype by SEB. *Psychological Science*, 29(05), 1116-1118. <https://doi.org/10.16719/j.cnki.1671-6981.2006.05.021>
- Ma, F., & Liang, N. (2008). A study on implicit mathematics gender stereotype by IAT. *Psychological Science*, 31(01), 35-39. <https://doi.org/10.16719/j.cnki.1671-6981.2008.01.010>
- Maple, S. A., & Stage, F. K. (1991). Influences on the choice of math/science major by gender and ethnicity. *American Educational Research Journal*, 28(1), 37-60. <https://doi.org/10.3102/0002831202800103>
- Marcenaro-Gutiérrez, O., Lopez-Agudo, L. A., & Ropero-García, M. A. (2018). Gender differences in adolescents' academic achievement. *Young*, 26(3), 250-270. <https://doi.org/10.1177/1103308817715163>
- Martinot, D., Bagès, C., & Désert, M. (2011). French Children's Awareness of Gender Stereotypes About Mathematics and Reading: When Girls Improve Their Reputation in Math. *Sex Roles*, 66(3-4), 210-219. <https://doi.org/10.1007/s11199-011-0032-3>
- Marx, D. M., & Roman, J. S. (2002). Female role models: Protecting women's math test performance. *Personality and Social Psychology Bulletin*, 28(9), 1183-1193. <https://doi.org/10.1177/01461672022812>
- McGhee, M. R., Johnson, N., & Liverpool, J. (2001). Assessing psychometric properties of the sex-role egalitarianism scale (SRES) with African Americans. *Sex Roles*, 45(11), 859-866. <https://doi.org/10.1023/A:1015648621679>
- Mierke, J., & Klauer, K. C. (2003). Method-specific variance in the implicit association test. *Journal of Personality and Social Psychology*, 85(6), 1180-1192. <https://doi.org/10.1037/0022-3514.85.6.1180>
- Miller, D. I., Eagly, A. H., & Linn, M. C. (2015). Women's representation in science predicts national gender-science stereotypes: Evidence from 66 nations. *Journal of Educational Psychology*, 107(3), 631. <https://doi.org/10.1037/edu0000005>
- Morin-Messabel, C., Ferrière, S., Martinez, F., Devif, J., & Reeb, L. (2017). Counter-stereotypes and images: an exploratory research and some questions. *Social Psychology of Education*, 20(1), 1-13. <https://doi.org/10.1007/s11218-017-9370-5>
- Morrissey, K., Hallett, D., Bakhtiar, A., & Fitzpatrick, C. (2019). Implicit math-gender stereotype present in adults but not in 8th grade. *Journal of Adolescence*, 74, 173-182. <https://doi.org/10.1016/j.adolescence.2019.06.003>
- Nosek, B. A. (2005). Moderators of the relationship between implicit and explicit evaluation. *Journal of Experimental Psychology: General*, 134(4), 565-584. <https://doi.org/10.1037/0096-3445.134.4.565>
- Nosek, B. A. (2007). Implicit-explicit relations. *Current directions in psychological science*, 16(2), 65-69. <https://doi.org/10.1111/j.1467-8721.2007.00477.x>
- Nosek, B. A., Banaji, M. R., & Greenwald, A. G. (2002). Math=Male, Me=Female, therefore Math \neq Me. *Journal of Personality and Social Psychology*, 83, 44-59. <https://doi.org/10.1037/0022-3514.83.1.44>
- Nosek, B. A., Greenwald, A. G., & Banaji, M. R. (2005). Understanding and using the Implicit Association Test: II. Method variables and construct validity. *Personality and Social Psychology Bulletin*, 31(2), 166-180. <https://doi.org/10.1177/01461672042714>
- Nosek, B. A., Greenwald, A. G., & Banaji, M. R. (2007). The implicit association test at Age 7: a methodological and conceptual review. In J. A. Bargh (Ed.), *Automatic Processes in Social Thinking and Behavior* (pp. 265-292).
- Nosek, B. A., & Smyth, F. L. (2007). A multitrait-multimethod validation of the Implicit Association Test:

- implicit and explicit attitudes are related but distinct constructs. *Experimental psychology*, 54(1), 14-29. <https://doi.org/10.1027/1618-3169.54.1.14>
- Nosek, B. A., Smyth, F. L., Hansen, J. J., Devos, T., Lindner, N. M., Ranganath, K. A., Smith, C. T., Olson, K. R., Chugh, D., & Greenwald, A. G. (2007). Pervasiveness and correlates of implicit attitudes and stereotypes. *European Review of Social Psychology*, 18(1), 36-88. <https://doi.org/10.1080/10463280701489053>
- Nosek, B. A., Smyth, F. L., Sriram, N., Lindner, N. M., Devos, T., Ayala, A., Bar-Anan, Y., Bergh, R., Cai, H., Gonsalkorale, K., Kesebir, S., Maliszewski, N., Neto, F., Olli, E., Park, J., Schnabel, K., Shiomura, K., Tulbure, B. T., Wiers, R. W., Somogyi, M., Akrami, N., Ekehammar, B., Vianello, M., Banaji, M. R., & Greenwald, A. G. (2009). National differences in gender–science stereotypes predict national sex differences in science and math achievement. *PANS*, 106(26), 10593–10597. <https://doi.org/10.1073/pnas.0809921106>
- Olson, M. A., & Fazio, R. H. (2003). Relations between implicit measures of prejudice: What are we measuring? *Psychological Science*, 14(6), 636-639. <https://doi.org/10.1046/j.0956-7976.2003.psci.1477.x>
- Osgood, C. E., Suci, G. J., & Tannenbaum, P. H. (1957). *The measurement of meaning*. University of Illinois press.
- Piatek-Jimenez, K., Cribbs, J., & Gill, N. (2018). College students’ perceptions of gender stereotypes: making connections to the underrepresentation of women in STEM fields. *International Journal of Science Education*, 40(12), 1432-1454. <https://doi.org/10.1080/09500693.2018.1482027>
- Plante, I., Theoret, M., & Favreau, O. E. (2009). Student gender stereotypes: Contrasting the perceived maleness and femaleness of mathematics and language. *Educational Psychology*, 29(4), 385-405. <https://doi.org/10.1080/01443410902971500>
- Qian, M., Luo, S., Zhang, G., Chen, P., & Yao, P. (1999). A preliminary survey of gender stereotypes. *Chinese Journal of Applied Psychology*, 5(1), 14-19.
- Qin, Q., & Yu, H. (2001). A survey of gender role stereotypes. *Psychological Science*, 24(5), 2. <https://doi.org/10.16719/j.cnki.1671-6981.2001.05.022>
- Rachmawaty, N., Iswari, W. P., & Astuti, N. (2020). Do Contextual Factors and Gender Influence Students’ Language Attitude in Learning English? 2nd Educational Sciences International Conference (ESIC 2019),
- Ren, Y. (2008). Research on Chinese Traditional Confucian Responsibility Psychology Thought. *Acta Psychologica Sinica*(11), 1121-1228. <https://doi.org/10.3724/SP.J.1041.2008.01221>
- Retelsdorf, J., Schwartz, K., & Asbrock, F. (2015). “Michael can’t read!” Teachers’ gender stereotypes and boys’ reading self-concept. *Journal of Educational Psychology*, 107(1), 186-194. <https://doi.org/10.1037/a0037107>
- Rosenkrantz, P., Vogel, S., Bee, H., Broverman, I., & Broverman, D. M. (1968). Sex-role stereotypes and self-concepts in college students. *Journal of consulting and clinical psychology*, 32(3), 287-295. <https://doi.org/10.1037/h0025909>
- Schimmack, U. (2021). The Implicit Association Test: A method in search of a construct. *Perspectives on Psychological Science*, 16(2), 396-414. <https://doi.org/10.1177/1745691619863798>
- Sekaquaptewa, D., Espinoza, P., Thompson, M., Vargas, P., & von Hippel, W. (2003). Stereotypic explanatory bias: Implicit stereotyping as a predictor of discrimination. *Journal of Experimental Social Psychology*, 39(1), 75-82. [https://doi.org/10.1016/S0022-1031\(02\)00512-7](https://doi.org/10.1016/S0022-1031(02)00512-7)
- Smeding, A. (2012). Women in Science, Technology, Engineering, and Mathematics (STEM): An Investigation of Their Implicit Gender Stereotypes and Stereotypes’ Connectedness to Math Performance. *Sex Roles*, 67(11-12), 617-629. <https://doi.org/10.1007/s11199-012-0209-4>

- Song, S. (2014). *Study on the Mathematical Gender Stereotype and Its Threat Effects*. The World Book Publishing in Guangdong.
- Song, S., Lan, X., & Wu, S. (2012). Subject stereotypes:covert education injustice. *Journal of Teaching and Management*(18), 9-12.
- Spence, J. T. (1984). Gender identity and its implications for the concepts of masculinity and femininity. *Nebr Symp Motiv*, 32(4), 59-95.
- Steele, C. M. (1998). Stereotyping and its threat are real. *American Psychologist*, 53(6), 680-681. <https://doi.org/10.1037/0003-066X.53.6.680>
- Stereotypes. In. (2003). *The Comprehensive Dictionary of Psychology*.
- Tan, L. (2016). *Annual Report on Gender Equality and Women's Development in China(2013-2015)*. social sciences academic press(CHINA).
- Tosi, J. D., Ledesma, R. D., Lázaro, C. M. D., & Poó, F. M. (2020). Implicit attitudes towards risky driving behaviors: Evidence of validity for the implicit association test. *Journal of safety research*, 75, 284-291. <https://doi.org/10.1016/j.jsr.2020.08.008>
- Tsui, M. (2007). Gender and mathematics achievement in China and the United States. *Gender Issues*, 24, 1-11. <https://doi.org/10.1007/s12147-007-9044-2>
- Uhlmann, E. L., Greenwald, A., Poehlmann, A., & Banaji, M. (2009). Understanding and Using the Implicit Association Test: III. Meta-Analysis of Predictive Validity. *Journal of Personality and Social Psychology*, 97(1), 17-41. <https://doi.org/10.1037/a0015575>
- Van Bavel, J., Schwartz, C. R., & Esteve, A. (2018). The reversal of the gender gap in education and its consequences for family life. *Annual Review of Sociology*, 44, 341-360. <https://doi.org/10.1146/annurev-soc-073117-04121>
- Wen, F., Zuo, B., Wang, Y., Wu, Y., Fang, Z., & Ma, S. (2020). The (continuous) nature of perceived gender counter-stereotype: A threshold model of gender stereotype maintenance. *Archives of Sexual Behavior*, 49(7), 2511-2530. <https://doi.org/10.1007/s10508-020-01763-2>
- Wen, Z., & Ye, B. (2014). Analyses of mediating effects: The development of methods and models. *Advances in Psychological Science*, 22(5), 731-745. <https://doi.org/10.3724/SP.J.1042.2014.00731>
- Whitehead, J. M. (1996). Sex stereotypes, gender identity and subject choice at A - level. *Educational research*, 38(2), 147-160. <https://doi.org/10.1080/0013188960380203>
- Wilson, T. D., Lindsey, S., & Schooler, T. Y. (2000). A model of dual attitudes. *Psychological Review*, 107(1), 101-126. <https://doi.org/10.1037//0033-295x.107.1.101>
- Xie, F., Yang, Y., & Xiao, C. (2022). Gender-math stereotypes and mathematical performance: the role of attitude toward mathematics and math self-concept. *European Journal of Psychology of Education*, 1-14. <https://doi.org/10.1007/s10212-022-00631-y>
- Xu, D. (2003). A study on the gender effect of gender stereotypes. *Journal of Psychological Science*(04), 741-742. <https://doi.org/10.16719/j.cnki.1671-6981.2003.04.048>
- Yang, J., Ni, X., Tang, L., & Duan, A. (2016). The impact of sports stereotype's on the sports participation of undergraduate female students. *SPORT SCIENCE AND TECHNOLOGY*, 37(06), 39-40. <https://doi.org/10.14038/j.cnki.tyjk.2016.06.095>
- Ying, G., & Xiangcai, H. (2015). A stereotypic explanatory bias study of college students' occupational gender stereotype. *Canadian Social Science*, 11(3), 141-145. <https://doi.org/10.3968/6468>
- Yu, H., & Liang, N. (2005). Stereotypic Explanatory Bias(SEB):a new index to show people's implicit attitudes. *Psychological Science*(01), 42-44. <https://doi.org/10.16719/j.cnki.1671-6981.2005.01.010>
- Yu, K. (2016). Analysis of gender differences in junior high school students' academic performance based on the data of the secondary school entrance examination. *Journal of Liaoning Normal University(Natural*

- Science Edition*), 39(05), 85-90. <https://doi.org/10.16216/j.cnki.lsxwbk.201605085>
- Yu, Y. (2003). A study on college students' occupational prejudice and Occupation-sex stereotype. *Psychological Science*(04), 672-675. <https://doi.org/10.16719/j.cnki.1671-6981.2003.04.025>
- Zhang, L. (2014). The state and thinking of contemporary college students' gender equality awareness. *Journal of Zhengzhou University(Philosophy and Social Science Edition)*, 47(06), 37-40.
- Zhang, L., Guo, A., & Hou, J. (2002). A comparative study of gender role equality attitudes between chinese and american college students. *Psychological Science*, 25(02), 219-221. <https://doi.org/10.16719/j.cnki.1671-6981.2002.02.028>
- Zhang, Y. (2021). *Inter-group differences of occupational gender stereotypes from both explicit and implicit perspectives* [Master, Tianjin Normal University].
- Zhao, W., & Zheng, X. (2016). A comparative study of regional stereotypes between HongKong and Mainland undergraduates. *Journal of South China Normal University (Social Science Edition)* (02), 85-94.
- Zuo, B. (2015). *Stereotypes Content and Form*. Central China Normal University Press.
- Zuo, B., & Liu, X. (2006). The researches of implicit gender stereotype based on IAT and SEB. *Psychological Development and Education*, 22(4), 7. <https://doi.org/10.16187/j.cnki.issn1001-4918.2006.04.010>
- Zuo, B., & Wen, F. (2011). Occupational stereotype: personal involvement and evaluating bias. *Chinese Journal of Clinical Psychology* 19(2), 149-153. <https://doi.org/10.16128/j.cnki.1005-3611.2011.02.025>

Appendix

I. Instruction and demographic information

Hello, classmate. We are doing a gender related survey, and the following questions need your answers. Please read the questions carefully and do not omit them. At the same time, the survey is anonymous. Please answer truthfully, without fear of privacy disclosure. The collected questionnaire is only for research purposes. Please fill in your basic information first.

The last four digits of the mobile phone tail number: _____

Gender: male female

Age: _____

Grade: _____

Major category: liberal arts science and engineering

Residence: urban rural

Math score of college entrance examination: _____

English score of college entrance examination: _____

Now let's begin to answer the question. Read the following statements carefully and make judgments. Please answer your thoughts truthfully and click the corresponding number. Please don't miss out the questions.

II. Trait Gender Stereotypes Scale

Which five words do you think best describe the characteristics of men:

_____, _____, _____, _____, _____

Which five words do you think best describe the characteristics of women:

_____, _____, _____, _____, _____

III. Sex Role Egalitarianism Scale-BB(SRES-BB)

1. Like female, male also need to take family finance courses.
2. Women are as capable as men of making important business decisions.
3. Qualified female students should be encouraged to engage in technical work after graduation.
4. Both husband and wife are responsible for cleaning the dishes at home.
5. A mother is better suited to baby care than a father.

6. Father has more authority than mother in family education.
7. Mothers are better suited than fathers to prepare for their children's birthday parties.
8. It is the mother's responsibility to take care of children who wake up at night.
9. Men and women should be given equal opportunities for vocational training.
10. Compared with men, women who are drunk are more damaging to their self-image.
11. When preparing for a family party, the wife knows better than the husband who to invite.
12. Women should not enter the traditional male career field.
13. In vocational training, male employees should be allowed to participate in those expensive training programs, rather than women.
14. The man should be the head of the family.
15. Men should not enter the traditional female career field.
16. When faced with career choices, the wife had better let her husband make decisions for her.
17. When dating, women should not act smarter than men.
18. Women love to gossip more than men.
19. A husband should not meddle in his family affairs.
20. A mother is better than a father at changing a baby's diaper.
21. Compared with women, men have a stronger interpersonal network.
22. Like men, women have the ability to manage a company well.
23. When receiving an invitation to a party, the wife, not the husband, should decide whether to attend.
24. When granting student loans, male and female college students should be treated equally.
25. Men and women should be treated equally in vocational training.

IV. Explicit Subject Gender Stereotypes Scale

1. Mathematics is suitable for male.
2. Chemistry is suitable for male.
3. Physics is suitable for male.
4. Biology is suitable for male.
5. Architecture is suitable for male.
6. History is suitable for male.
7. Pedagogy is suitable for male.

8. English is suitable for male.
9. Music is suitable for male.
10. Literature is suitable for male.
11. Mathematics is suitable for female.
12. Chemistry is suitable for female.
13. Physics is suitable for female.
14. Biology is suitable for female.
15. Architecture is suitable for female.
16. History is suitable for female.
17. Pedagogy is suitable for female.
18. English is suitable for female.
19. Music is suitable for female.
20. Literature is suitable for female.

V. Explicit Math Gender Stereotypes Scale

1. Female are as good at math as male.
2. I can hardly believe that a woman can be a math genius.
3. Female and male are equally suitable for learning mathematics.
4. When encountering math problems, female usually need the help of male.
5. I believe that woman can solve important mathematical problems, just like man.
6. I have more confidence in the mathematical answers from male than from female.
7. Woman can also perform as well as man in mathematics.
8. Girls who like math are a little strange.
9. Woman also have enough logical brains to learn mathematics well.
10. In mathematics, boys are no better than girls in essence.
11. Mathematics belongs to male subjects, while language belongs to female subjects.

VI. Explicit Language Gender Stereotypes Scale

1. Male are as good at language as female.
2. I can hardly believe that a man can be a language genius.

3. Male and female are equally suitable for learning language.
4. When encountering language problems, male usually need the help of female.
5. I believe that man can solve important language problems, just like woman.
6. I have more confidence in the language answers from female than from male.
7. Man can also perform as well as woman in language.
8. Boys who like language are a little strange.
9. Male also have enough brains to learn language well.
10. In language, girls are no better than boys in essence.
11. Language belongs to female subjects, while mathematics belongs to male subjects

VII. Explicit Math Attitude Scale

Good	-3	-2	-1	0	1	2	3	Bad
Happy	-3	-2	-1	0	1	2	3	Sad
Pleasure	-3	-2	-1	0	1	2	3	Disgusting
Beautiful	-3	-2	-1	0	1	2	3	Ugly
Love	-3	-2	-1	0	1	2	3	Fear
For male	-3	-2	-1	0	1	2	3	For female

VIII. Explicit Language Attitude Scale

Good	-3	-2	-1	0	1	2	3	Bad
Happy	-3	-2	-1	0	1	2	3	Sad
Pleasure	-3	-2	-1	0	1	2	3	Disgusting
Beautiful	-3	-2	-1	0	1	2	3	Ugly
Love	-3	-2	-1	0	1	2	3	Fear
For male	-3	-2	-1	0	1	2	3	For female

IX. Target categories, attribute categories and items of four IAT

IAT1	Target		Attribute	
Category	Male	Female	Masculine	Feminine
Items	man son father husband boy	women daughter mothers wife girl	independent competitive forthright brave adventurous	dependent weak gentle kind obedient

IAT2	Target		Attribute	
Category	Male	Female	Science	Liberal Arts
Items	man son father husband boy	women daughter mothers wife girl	mathematics chemistry physics biology architecture	history pedagogy English literature music

IAT3	Target		Attribute	
Category	Male	Female	Math	Language
Items	man son father husband boy	women daughter mothers wife girl	algebra equation subtraction geometry square	English grammar poetry sentences Chinese

IAT4	Target		Attribute	
Category	Math	Language	Positive	Negative
Items	algebra equation subtraction geometry square	English grammar poetry sentences Chinese	good happy pleasure beautiful love	bad sad disgusting ugly fear

X. The actual instructions displayed on computer screen for IAT1

From left to right: Welcome page→General instructions→B1→B2→B3→B4→B5→B6→B7→End

Welcome to this study!

Please read the following instructions carefully!

Press SPACEKEY to star.

You will complete a word classification task. The words belonging to each category are listed below. These words will be displayed in the middle of the screen one by one. Your task is to determine which category the word belongs to by pressing the key. This part will take about 7 or 8 minutes.

Category	Males	Females	Masculine	Feminine
Items	man son father husband boy	women daughter mothers wife girl	independent competitive forthright brave adventurous	dependent weak gentle kind obedient

Notice:

- Every word can be classified into a certain category, and most of them are easy to classify.
- If you respond too slowly, the data may lose value. Please try your best to be fast and correct.
- It is normal that a quick response may lead to a small number of errors.
- For best results, avoid distractions and focus.

Press SPACEBAR to start

Male **Female**

Place your forefinger on the E key and the I key of the keyboard (please always use these two fingers). The "male" and "female" on the top of the screen are categories, and the words to be classified will be presented in the center of the screen one by one. When the words presented belong to the left male, press the E key with the left forefinger; When the words presented belong to the right female, press the I key with the right forefinger. *Please respond as quickly and accurately as possible.* Too slow response or too many errors will lead to inaccurate results.

Press SPACEBAR to start

Masculine **Feminine**

Notice: The above categories have changed, and the words to be classified will also change, but the rules will not change. When the words presented belong to the left masculine words, press the E key; When the presented words belong to the right feminine words, press the I key. *Please respond as quickly and accurately as possible.*

Press SPACEBAR to start

Male **Female**
Masculine **Feminine**

Notice: The four categories previously presented separately now appear together. When the words presented belong to the left male or masculine words, please press the E key; When the words presented belong to the right female or feminine words, please press the I key. *Please respond as quickly and accurately as possible.*

Press SPACEBAR to start

Male **Female**
Masculine **Feminine**

According to the previous rules, do it again!

Press SPACEBAR to start

Feminine **Masculine**

Notice: There are only two category above, but the positions are interchanged. Press E key when the words presented belong to the left feminine words. Press the I key when the presented words belong to the right masculine words. *Please respond as quickly and accurately as possible.*

Press SPACEBAR to start

Male **Female**
Feminine **Masculine**

Note: The four categories above appear in a new combination. When the words presented belong to the left male or feminine words, press the E key; When the words presented belong to the right female or masculine words, press the I key. *Please respond as quickly and accurately as possible.*

Press SPACEBAR to start

Male **Female**
Feminine **Masculine**

According to the previous rules, do it again!

Press SPACEBAR to start

Thank you for your participation!

Please take a break and wait for the researcher to arrange!

XI. The actual pages on computer screen for core experimental procedure of B1

From left to right:Instructions→Fixation→Stimulus/Probe→Feedback→Buffer Interval

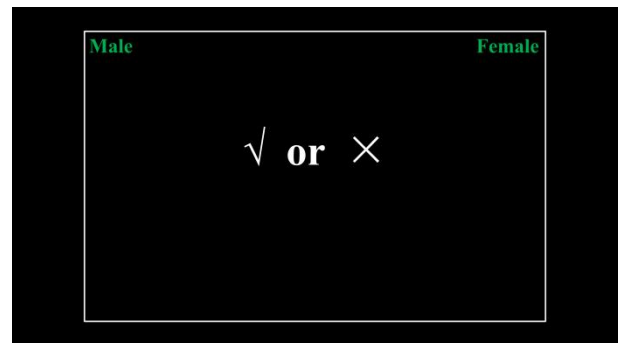
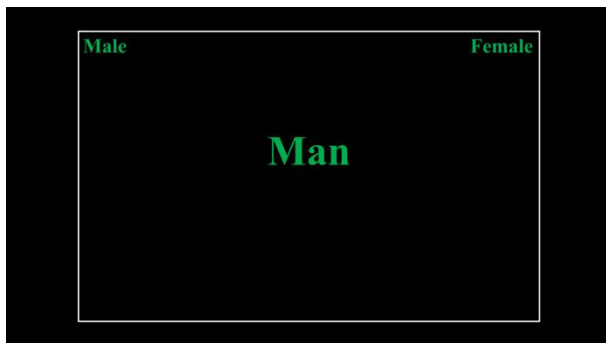
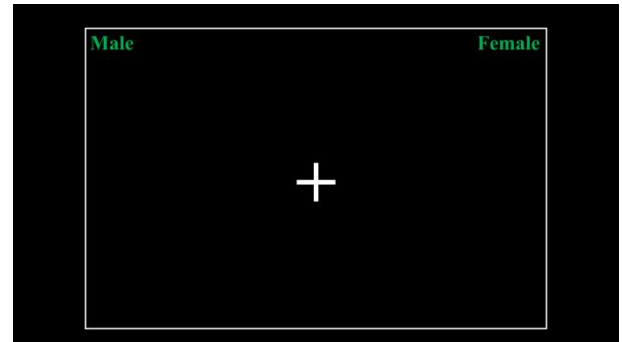
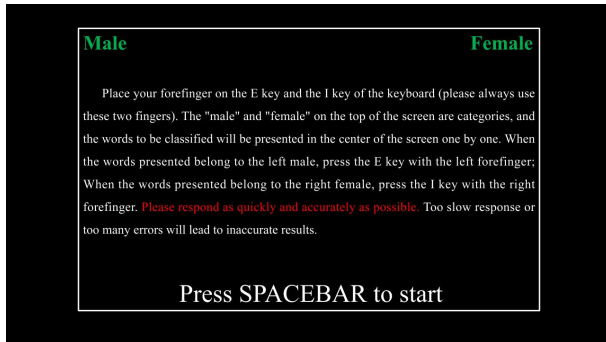

XII. Photos of the research process



Acknowledgment

I begin by expressing my sincere appreciation to the participants of this study, the freshman students majoring in Mathematics and Chinese Language and Literature at Sichuan University of Science and Engineering. Their invaluable support has been critical to the success of this research.

Next, I extend my heartfelt gratitude to my doctoral advisor, Dr. Miroslav Chráska, for his unwavering support and guidance throughout my research journey. His expertise, insights, and dedication have been instrumental in shaping my academic pursuits and helping me to reach my full potential.

I also want to acknowledge the invaluable contributions of Professor Anthony Greenwald (psychology professor at the University of Washington), Professor Brian Nosek (psychology professor at the University of Virginia), and Professor Cai Huajian (psychology professor at the Institute of Psychology at the Chinese Academy of Sciences). Their expert advice and patient responses to my inquiries about various issues related to the IAT have been of immense help in shaping the direction of our research and ensuring its quality.

Furthermore, I am deeply grateful for the support and encouragement extended by several individuals at Sichuan University of Science and Engineering. These include Sun Shan, Director of the Academic Affairs Office, Xie Hua, Dean of the School of Education and Psychology, Zhao Xue, Vice Dean of the School of Education and Psychology, Dong Zhengping, Director of the Student Affairs Office in the School of Humanities, Yang Xinyu, a faculty member in the School of Humanities, and Zhou Peiyixuan, a faculty member in the School of Mathematics and Software Science. Their contributions have been crucial to the success of this research.

I must also express my heartfelt thanks to my family for their unwavering support, encouragement, and patience during this time. Their love and understanding have been a constant source of inspiration and motivation, and I could not have accomplished this without them.

Lastly, I want to acknowledge and thank myself. Despite facing numerous setbacks, I persevered and never gave up on my dreams.