

BRNO UNIVERSITY OF TECHNOLOGY

VYSOKÉ UČENÍ TECHNICKÉ V BRNĚ

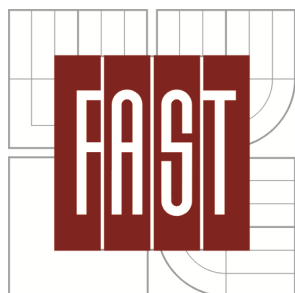

FACULTY OF CIVIL ENGINEERING

INSTITUTE OF BUILDING STRUCTURES

FAKULTA STAVEBNÍ

ÚSTAV POZEMNÍHO STAVITELSTVÍ

EXPERIMENTAL DRYING AND DESALINATION OF BRICKS, SANDSTONES AND MASONRY UNDER AN APPLIED ELECTRIC FIELD

EXPERIMENTÁLNÍ ODVLHČOVÁNÍ A ODSOLOVÁNÍ CIHEL, PÍSKOVců A ZDIVA VLIVEM
ELEKTRICKÉHO POLE

DISSERTATION

Disertační práce

AUTHOR

AUTOR

ING. ONDŘEJ MATYŠČÁK

SUPERVISOR

VEDOUCÍ PRÁCE

PROF. ING. MILOSLAV NOVOTNÝ, CSC.

BRNO 2014

ACKNOWLEDGEMENT

The department of the civil engineering in Brno is acknowledged for the financial support and the possibility to study ph.D course at Brno University of Technology.

Denmark Technical University in Lyngby is acknowledged for the materials, the usage of the experimental laboratories and for its knowledge support.

This dissertation was led by supervisor prof. Ing. Miloslav Novotný, CSc. The results of dissertation were discussed with Lisbeth M. Ottosen who is greatly acknowledged. Further acknowledgement is for Ebba Schnell for the material supply and for all my colleagues who contributed to this dissertation.

Brno, may 2014

Ing. Ondřej Matyščík

ACKNOWLEDGEMENT	3
THE USED SYMBOLS AND UNITS	11
symbol unit description	11
symbol unit description	12
symbol unit description	13
symbol unit description	14
INTRODUCTION.....	15
1 MOISTURE IN THE BUILDING MATTERS.....	16
1.1 General knowledge about the hygric properties of the building matters.....	16
1.1.1 Physical properties of the moisture influence on the building matters	18
Absorption.....	19
Equilibrium moisture content.....	20
Steady-state and the industrial moisture	21
The critical moisture level.....	22
Chemical potential of the moisture (water).....	22
The conductivity of the moisture (water).....	23
The transport of the moisture in the brickwork	24
Capillary attraction.....	24
Diffusion of the water vapour	26
Condensation.....	27
Brickwork chemistry	30
The water transport due to other mechanisms	31
1.2 The methods for the drying of the building materials.....	32
1.2.1 Direct methods.....	33
1.2.2 Supplementary direct methods	33
1.2.3 The indirect methods	33

1.2.4	The supplementary indirect methods.....	33
1.3	The building matters such as the porous materials.....	33
1.3.1	The methods for the dewatering of the building matters and the constructions.....	35
	Equipments for the drying under the influence of the hot air	36
	Radiation panels	37
	The condensing dehumidifiers	38
	Adsorptive dehumidifiers.....	39
	Ventilation–windows, doors	40
	The microwave drying	41
2	SALTS	43
2.1	Transfer of the salts and the moisture	43
2.2	Transport of the moisture and ions.....	43
2.3	The viscosity – the property of a solution	46
2.4	The structure – the influence of the structure on the evaporation.....	47
2.5	The structure – the influence of the relative humidity	47
2.6	The damaging effect of the crystallization.....	47
2.6.1	The crystallization pressure	48
2.6.2	The hydration pressure	49
2.6.3	Other theories.....	49
2.7	The climate and its influence on the salt formation.....	49
2.8	The damaging concentration related to the salt anions.....	50
3	ELECTROKINETICS.....	52
3.1	Electromigration	52
3.2	The problems during the electromigration.....	53
3.3	The migration of the ions and their velocity under an applied electric field.....	54
3.4	Electro-osmosis.....	55

3.5	Electrode processes	56
3.6	The changes of the matrix	57
3.7	The dependence on the material.....	57
3.8	The change of the conditions during the experiments.....	58
4	OSMOTIC METHODS - THE USE IN PRACTICE	59
4.1	The passive electro-osmosis.....	59
4.2	Galvano-osmosis.....	59
4.3	Use of the passive electro-osmosis and galvano-osmosis.....	60
4.4	The active electro-osmosis	60
5	DRYING AND DESALINATION OF THE MATTERS UNDER AN APPLIED ELECTRIC FIELD	62
5.1	The use of electrokinetics for the drying and the desalination of the matters	62
5.2	Poulticing	62
5.2.1	Classic poulticing.....	62
5.2.2	Electrokinetics	64
5.2.3	The use of electrokinetics for the drying of bricks and brickwork	64
5.2.4	The characteristic of the dried and desalinated materials....	64
5.3	Summary of the basic knowledge about the electrokinetics	66
5.3.1	The advantages and disadvantages of electrokinetics for the drying and the desalination	67
6	SPECIFICATION AND THE GOALS OF THE DISSERTATION ...	68
6.1	The specification of the issue.....	68
6.2	The goals of the dissertation.....	69
6.2.1	The optimization of the closed laboratory setup for the dewatering of the tap water saturated bricks due to electro-osmosis using the different types of clay poultices	69

6.2.2	Desalination of the sandstones under the laboratory conditions using one type of clay poultice.....	69
6.2.3	The optimization of the closed laboratory setup for the desalination of the bricks saturated with sodium chloride solution using the different types of clay poultices	70
6.2.4	Desalination of a brickwork in the pilot test.....	70
6.2.5	Desalination of the sandstone wall in the pilot scale test on the basis of laboratory results.....	70
7	THE METHODS USED IN THE DISSERTATION	71
7.1	Theoretical methods.....	71
7.1.1	The study of literature and the consultation with experts....	71
7.2	Experimental methods.....	71
7.2.1	Laboratory methods	71
7.2.2	Methods used in the pilot test	72
7.2.3	The used equipments	72
7.3	The comparative method.....	73
8	EXPERIMENTAL DRYING AND DESALINATION UNDER AN APPLIED ELECTRIC FIELD	74
8.1	EXPERIMENT 1 – To find out the combination of the clay poultices which is the most efficient for the dewatering of the tap water saturated bricks due to electro-osmosis under an applied electric field	74
8.1.1	Introduction.....	74
8.1.2	The goals of the experiment 1	74
8.1.3	The experimental section.....	74
8.1.4	Materials for experiments	75
8.1.5	Analytical.....	75
8.1.6	The experimental setup.....	76
8.1.7	The experimental series	77

8.1.8	Results and discussion	79
8.1.9	The conclusion.....	87
8.2	EXPERIMENT 2 – Desalination of sandstones using clay poultices with an applied electric field	89
8.2.1	Introduction.....	89
8.2.2	The goals of the experiment 2	89
8.2.3	The experimental section.....	89
8.2.4	Materials for experiments	91
8.2.5	The analytical.....	91
8.2.6	The experimental setup.....	92
8.2.7	The experimental series	93
8.2.8	The results and discussion	95
8.2.9	The conclusion.....	104
8.3	The additional experiment to experiment 2.....	106
8.3.1	The main goals of the additional experiment	106
8.3.2	The experimental section.....	106
8.3.3	Materials for experiments	108
8.3.4	The analytical.....	108
8.3.1	The experimental setup.....	109
8.3.2	The experimental series	110
8.3.3	The results and discussion	111
8.3.4	The conclusion.....	118
8.4	EXPERIMENT 3 – Desalination of the bricks contaminated with the sodium chloride under an applied electric field.....	119
8.4.1	Introduction.....	119
8.4.2	The goals of the experiment 3	119
8.4.3	The experimental section.....	120
8.4.4	Materials for experiments	120

8.4.5	The analytical.....	120
8.4.6	The experimental setup.....	121
8.4.7	The experimental series	122
8.4.8	The results and discussion	122
8.4.9	The conclusion.....	127
8.5	EXPERIMENT 4 – Desalination of a masonry in the pilot test under an applied electric field.....	128
8.5.1	Introduction.....	128
8.5.2	The goals of the experiment 4	128
8.5.3	The experimental section.....	128
8.5.4	The materials for experiment.....	129
8.5.5	The analytical.....	130
8.5.6	The experimental setup.....	130
8.5.7	The experimental series	130
8.5.8	The results and discussion	132
8.5.9	The conclusion.....	135
9	CONCLUSION AND FINDINGS OF SCIENTIFIC KNOWLEDGE	136
9.1	The optimization of the closed laboratory setup for the dewatering of the tap water saturated bricks due to electro-osmosis using different types of the clay poultices	136
9.2	Desalination of the sandstones under the laboratory conditions using one type of clay poultice.....	136
9.3	The optimization of the closed laboratory setup for the desalination of the bricks contaminated with sodium chloride using the different types of clay poultices.....	137
9.4	The use of the electrokinetics for the desalination of constructions such as brickwork and sandstone walls	137
9.4.1	The choice of the suitable type of the clay poultice	138

9.4.2	The recommended setup for the desalination of the brickwork with the plaster when an electric field is applied	138
9.4.3	The recommended setup for the desalination of the sandstone wall under an applied DC field using the clay poultices	142
9.5	Assumption for the next experimental work based on the results from the dissertation	145
	ČESKÝ ABSTRACT	147
	BIBLIOGRAPHY	148
	PUBLICATION FROM AUTHOR.....	153
	APPENDICES	154

THE USED SYMBOLS AND UNITS

symbol	unit	description
b	[m]	the thickness of the brickwork,
c	[mol·l ⁻¹]	the concentration of ions in the water,
C	[mol·l ⁻¹]	the saturation concentration inside the pore,
C _o	[mol·l ⁻¹]	the concentration of the ions in the bulk solution,
d	[m]	the thickness of the layer of the plaster or paints on the facades or their sprays,
d _μ	[m]	the diffusion resistance,
d _{μoverall}	[m]	the overall diffusion resistance,
Σd _{μ,i}	[m]	the sums of the partial diffusion resistances,
D(θ)	[m ² ·s ⁻¹]	the isothermal moisture diffusivity,
D _c	[m ² ·s ⁻¹]	the coefficient of ion diffusion,
D _{eff}	[m ² ·s ⁻¹]	the effective diffusion,
D _o	[m ² ·s ⁻¹]	the traditional diffusion,
F	[C·mol ⁻¹]	the Faraday constant,
G	[J]	free enthalpy,
h _a	[-], [%]	the relative humidity of the air,
h _l	[-], [%]	the relative humidity of the air/liquid inside the porous material,
H _v	[-]	the level of hydrophobization,
I	[A]	the current,
k _B	[J·K ⁻¹]	the Boltzmann constant,
k	[-]	the coefficient of the evaporation,
L	[m]	the length of a sample,
L	[mol ⁻¹]	the Avogadro constant,

symbol	unit	description
m_w	[kg]	a mass of the water,
m_i	[kg]	a mass of a matter,
m	[kg]	a weight of a material,
M	[kg·mol ⁻¹]	the molar mass,
n	[-]	the number of ions in the salt,
NV_{ws}	[%]	absorption under the boiling on the water surface,
$NV_{ws,f}$	[%]	absorption under the boiling with the forced submersion,
NV_{fs}	[%]	absorption under the forced submersion,
NV_v	[%]	the volumetric absorption,
NV	[%]	absorption,
$NV_{ws,h}$	[%]	the absorption due to the boiling on the water surface of the hydrophobic matter,
p	[Pa]	the pressure,
p	[%]	the porosity,
p_v	[Pa]	the partial pressure of the water vapour,
$p_{v,sat}$	[Pa]	the partial pressure of the water saturated vapour,
p_c	[Pa]	the capillary pressure,
P_c	[Pa]	the crystallization pressure,
pH	[-]	pH of material,
P_e	[-]	the Peclet's number
Q	[C]	the charge,
$q_{mt,1}$	[kg·m ⁻² ·s ⁻¹]	the density of a mass flow of liquid water by transmission,
$q_{mt,2}$	[kg·m ⁻² ·s ⁻¹]	the density of a mass transport of the liquid water by transmission,
q_v	[m·s ⁻¹]	the water flow,

symbol	unit	description
R	$[\text{J}\cdot\text{mol}^{-1}\cdot\text{K}^{-1}]$	the gas constant,
R	$[\text{mol}\cdot\text{l}^{-1}\cdot\text{s}^{-1}]$	the rate of the crystallization,
r_m	$[\text{m}]$	a radius of the pore,
t	$[\text{°C}]$	the ambient temperature of the air,
T	$[\text{K}]$	thermodynamic temperature,
T	$[\text{days}]$	the time necessary for the drying up of a building matter,
t	$[\text{s}]$	the time,
t_w	$[\text{°C}]$	the temperature of dew point,
U	$[\text{m}\cdot\text{s}^{-1}]$	the velocity of the water,
u	$[\text{m}^2\cdot\text{s}^{-1}\cdot\text{V}^{-1}]$	the ionic mobility,
V_w	$[\text{m}^3]$	the volume of the water,
V_t	$[\text{m}^3]$	the total volume of a porous matter (soil volume+water volume+air space),
V	$[\text{m}^3]$	a volume of a material,
V_v	$[\text{m}^3]$	the volume of void space,
V_s	$[\text{m}^3]$	the volume of solids,
v_c	$[\text{m}^3\cdot\text{l}^{-1}]$	the molar volume of the salt,
w	$[\%]$	the mass (gravimetric) water content of a matter,
w_w	$[\%]$	the mass of a sample before drying up,
w_d	$[\%]$	the mass of a sample after drying up,
w_{mc}	$[\%]$	a mass equilibrium moisture content,
Z	$[\text{C}\cdot\text{mol}^{-1}]$	the unit charge,
β	$[\text{kg}\cdot\text{m}^2\cdot\text{s}^{-1}]$	the mass transfer coefficient,
ρ_d	$[\text{kg}\cdot\text{m}^{-3}]$	the volumetric mass density of dried up sample,
ρ_w	$[\text{kg}\cdot\text{m}^{-3}]$	the volumetric mass density of the water,
ρ_s	$[\text{kg}\cdot\text{m}^{-3}]$	the volumetric mass density of a matter,

symbol	unit	description
θ_w	[°C]	the dew point,
θ	[%]	the volumetric water content,
θ_c	[-]	the total amount of the salt content in the porous matter (material),
τ	[s]	the time,
μ_u	[J·kg ⁻¹]	the chemical potential of the water contained in the material,
μ	[-]	the diffusion resistance factor,
κ_m	[m ² ·s ⁻¹]	coefficient of the moisture conductivity during the moisture gradient,
φ	[-], [%]	the relative humidity of the air,
γ	[N·m ⁻¹]	the tension of the surface - liquid/vapour interface.
φ	[°]	the contact angle - liquid/air and liquid/soil interface,
τ	[-]	the tortuosity factor,
ε	[-]	the constrictivity,
κ_t	[K ⁻¹]	coefficient of the moisture conductivity during the temperature gradient,

INTRODUCTION

The removal of the moisture from the building constructions and the desalination is currently discussed topic in the civil engineering. At the present time different methods are used both for the dewatering and for the desalination of the building materials. The existing methods are efficient for the dewatering and for the desalination but it is necessary not only to improve them for the higher efficiency but also to develop new ones. The problematic of the moisture and the salts in the building constructions is important because the moisture and salts dissolved in it can considerably change as the mechanical as the physical properties of the building materials. These properties influence the suitability of the used building materials and matters in the engineering practice. Basic demands for the used methods are the velocity, the efficiency and the economic factor both for the operation and for the cost of the used equipments. Time for the dewatering and the desalination may be long, moreover, the application of the methods is different in relation to the types of the building materials. The main problem of the desalination is that much knowledge in the area of the salts is needed to understand the whole process of the crystallization and its treatment. Within the frame of my dissertation I tried to dewater and to desalinate the bricks and the sandstones. Together with these issues, one of the main goals was to improve the laboratory setup which used the clay poultices for the dewatering and the desalination when an electric field was applied.

In the first part of the thesis, the basic theoretical principles about moisture and salts are described. In the second part, the results of my experimental work related to the dewatering and the desalination under an applied DC field are presented.

1 MOISTURE IN THE BUILDING MATTERS

The moisture is an important factor in the civil engineering. The moisture is the technical-physical quantity which has the influence on the majority of mechanical and physical properties of the building matters and constructions (brickwork). The moisture as quantity describes the state of the building matter (brickwork), construction in relation to the volume of the water in any state. Among the mechanical properties the moisture has influence on the fabrication, strength, cold resistance and lifetime of the building matters. Among the physical properties it influences mainly thermal-technical properties, which have a huge impact on the environment. Wet building matters can also suffer from the biological corrosion (fungi).

1.1 General knowledge about the hygric properties of the building matters

Building materials are rarely completely dried up because the water can penetrate into the materials during the production, storage etc. The climate influences the materials as well. The water in the matters can be transported by diffusion of the water vapour, transmission, capillarity, absorption or sorption.

In the engineering practice, the water can occur in three phases, e.g. the solid phase as ice, the liquid phase as the water and the gas phase as the water vapour. The building constructions such as outside walls, roofs, foundations are influenced by these phases mostly. The least influenced building constructions are the constructions with the lowest temperature and the moisture gradient and without the direct source of the moisture. From the view of the practice the most important properties for the moisture are sorption, absorption, capillarity, diffusion of the water vapour and the conductivity of the water. From the view of the rehabilitation of the existing buildings and constructions, it is necessary to know principles and behaviour of the water in these buildings and constructions. The moisture describes the state of the building matters (masonry), construction from the view of the water content in the matter in any phase.

The water (moisture) content is possible to calculate from the following equation:

$$w = \left(\frac{w_w - w_d}{w_d} \right) \cdot 100 \quad [\%] \quad (1.1)$$

where wa water (moisture) content [%]
 w_wthe mass of a sample before drying up [kg]
 w_d the mass of a sample after drying up [kg]

The following Table 1 shows the levels of the moisture in the brickwork. There are several levels of the moisture:

Table 1 The levels of the moisture in the brickwork. [1]

Levels of the moisture	Water content w [%]
Very low	$w < 3.0$
Low	$3.0 \leq w < 5.0$
Increased	$5.0 \leq w < 7.5$
High	$7.5 \leq w < 10.0$
Very high	$10.0 >$

The moisture of the building matter (brickwork) is affected by its own moisture of the building matter and by the relative humidity of indoor and outdoor climate during the lifetime.

If the temperature and humidity are in a constant stance, equilibrium between the moisture of a building matter and the humidity of the surrounding air is obtained. This stance is called equilibrium moisture content.

The moisture of the building matters is affected during the lifetime of the building matters by many aspects and is therefore variable. The moisture of the building matter until the end of the industrial process is called the industrial moisture. From then the industrial moisture gradually decreases or increases according to the surrounding climatic and the internal conditions until the moisture gets levelled off content. This stance of the moisture is called stable moisture.

[2]

1.1.1 Physical properties of the moisture influence on the building matters

The basic characteristics of the moisture influence on the building matters which have been investigated for many years in laboratories and testing rooms are porosity, absorption, capillarity and the equilibrium moisture content. Other physical properties of the water as the diffusion of the water vapour and the capillary conductivity of the water in the porous materials are also in the aim of the interest. Among the newest investigated physical properties belong the chemical potential of the moisture and the critical moisture content. [2] [3] [4]

The porosity

It is the overall percentage amount of a free space which is not filled with the solid particles. For the determination of the porosity p the following equation is used:

$$p = \left(\frac{V_v}{V_s} \right) \cdot 100 \quad [\%] \quad (1.2)$$

where V_vthe volume of void space [m³]

V_sthe volume of solids [m³]

The brickwork is characterized as a very porous material composed of a ceramic shard and a mortar. During the sanitation of the brickwork, it is necessary to take into account not only the porosity of the brickwork from which the amount of the water can be found out but also the distribution of the pores in the brickwork. In the practice, the pores of the brickwork are distributed non-uniformly. The shapes of the pores are simplified as the shapes of the cylinders about the definite radius. Thus the effective value of the pores radius has to be determined. The porous structure of the building matters contains the radius of the pores about different sizes from the smallest sizes as the sizes of the water molecules are up to the pores of the macroscopic sizes. According to Dubinin the pores are divided into three groups.

- 1st group – macroscopic pores about effective radius more than $2 \cdot 10^{-7}$ m;

- 2nd group – transitional pores about effective radius $2 \cdot 10^{-7} - 1.5 \cdot 10^{-9}$ m;
 - 3rd group – microscopic pores about effective radius less than $1.5 \cdot 10^{-9}$ m;
- [2] [3] [4]

Absorption

Absorption is characterised by the mass moisture which expresses the partial amount of the water which is absorbed by the dried up building matter when it is submerged in the water for some fixed time together with the conditions specified in the norm. From the absorption we can find out the overall amount of so-called open pores.

For the determination of absorption NV from the mass water contents the following equation is used:

$$NV = \left(\frac{w_w - w_d}{w_d} \right) \cdot 100 \quad [\%] \quad (1.3)$$

The volumetric absorption is recalculated from the following equation:

$$NV_v = \frac{NV \cdot \rho_d}{\rho_w} \quad [\%] \quad (1.4)$$

where w_w the mass of a sample before drying up [kg]
 w_d the mass of a sample after drying up [kg]
 ρ_d the volumetric mass density of dried up sample
 [kg·m⁻³]
 ρ_w the volumetric mass density of the water [kg·m⁻³]

In addition to the normalized methods, the absorption may be specified:

- under the cold conditions NV;
- under the cold conditions with the forced submersion NV_f;
- under boiling on the water surface NV_{ws};
- under boiling with the forced submersion NV_{ws,f};

The absorption of the building matters is affected by hydrophobic and hygroscopic properties of the building matters. Hydrophobic surface coating is

the treatment of the building matters with a matter or some cover which is hydrophobic. When this matter is used the absorption of the building matters is decreased. The level of the hydrophobization indicates how many times the absorption of thus hydrophobic matter is decreased in comparison with the initial state.

$$H_v = \frac{NV_{ws}}{NV_{ws,h}} \tag{1.5}$$

- where H_v the level of the hydrophobization
- NV_{ws} the absorption due to the boiling on the water surface of the non-hydrophobic matter [%]
- $NV_{ws,h}$ the absorption due to the boiling on the water surface of the hydrophobic matter [%]

If the brickwork contains salts the other property called hygroscopicity of the building matters takes place. This is the property of the salts. Hygroscopicity may be characterised as the property for the taking water spontaneously from the air in the surrounding. In the case of the brickwork, the absorption increases and in many cases the water content in the brickwork is multiplied in comparison with the brickwork without salts. [2] [3] [4]

Equilibrium moisture content

The equilibrium moisture content is the moisture which the matter takes from the ambient air during the steady temperature and humid conditions. In the case, the water has the influence on the porous building matters, the moisture absorbing from the ambient air on the touch between two layers under the influence of the intermolecular and surface forces, the term sorption is used. It is the expression for the absorption, adsorption together with the chemisorption. In the practice, the water vapour is the most important absorbent. If the partial air pressure in the object is lower than in the air which is in the surrounding, the

object takes the water vapour from the air. This physical process is called sorption.

If the partial air pressure in the object is higher than in the air which is in the surrounding, the object takes the water vapour away. This physical process is called desorption. If the temperature and the humid conditions are steady the equilibrium between the moisture in the object and the moisture in the ambient air gets the equilibrium state of the moisture. Equilibrium moisture content is characterized as the zero increment of the moisture and the temperature in the time under the condition:

$$\left| \frac{\partial w}{\partial r} \right|_{\tau \rightarrow \infty} \rightarrow 0 \quad \left| \frac{\partial t}{\partial \tau} \right|_{\tau \rightarrow \infty} \rightarrow 0 \tag{1.6}$$

Because this condition is practically unrealizable, the equilibrium moisture content is expressed from the dependence:

$$w_{mc} = f(\varphi) \text{ for } t = \text{constant} \tag{1.7}$$

- where w_{mc}a mass equilibrium moisture content [%]
- wa water (moisture) content [-], [%]
- t the ambient temperature of the air [°C]
- τ time [s]
- φ the relative humidity of the air [-], [%]

The equilibrium moisture content of the air is dependent on the temperature, the relative humidity of the air and on the atmospheric pressure. If the atmospheric pressure is constant the equilibrium moisture content of the air is dependant only on the temperature and the relative humidity of the ambient air.

Steady-state and the industrial moisture

The steady-state moisture is the moisture of the building matter or a construction which is stabilized during the use of the building matters or materials during a longer period of time. The industrial moisture is the moisture

which has the building matter just after its production. This type of the moisture is gradually decreasing under the influences of the climatic conditions and the internal conditions to the value of the steady-state moisture. [2] [3]

The critical moisture level

The critical moisture level is the maximal amount of the moisture acceptable in the building matter with which the building matter may be used in the practice. If the value of the critical moisture level is exceeded the changes in the building matter are extreme. The mechanical and the physical properties of the building matters are changed so significantly that the use of such matters or building materials in the practice is not recommended or might be even dangerous because the guaranteed properties such as strength, heat conductivity, chemical properties etc. are different. Its value is specified for the individual building matters according to the norms. [2] [3]

Chemical potential of the moisture (water)

Chemical potential of the moisture (water) is a thermodynamic potential of the water transport. Its gradient is an agent of the main transport process of the moisture. It is defined as a partial enthalpy change G according to the amount of the moisture content w under the constant pressure, temperature and the amount of other parts.

$$\mu_u = \left. \frac{\partial G}{\partial m_w} \right|_{p, T, m_i \neq m_w} \quad [\text{J} \cdot \text{kg}^{-1}] \quad (1.8)$$

- where μ_u the chemical potential of the water contained in the material [$\text{J} \cdot \text{kg}^{-1}$]
 G free enthalpy [J]
 p pressure [Pa]
 T thermodynamic temperature [K]
 m_i a mass of a matter [kg]
 m_w a mass of the water [kg]

$m_i \neq m_w$It signifies that the process occurs under the constant masses of all parts of the system m_i except the mass of the water contained in the matter m_w . The significance of the chemical potential is that it is possible to specify the moisture in the different position of the building matter (construction) and thus to estimate sources of the moisture. According to the law of thermodynamics the transport of the moisture is from the position with the higher chemical potential toward the position with the lower chemical potential. On the basis of this knowledge, it is possible to specify the direction of the moisture (water) transport. [2] [3]

The conductivity of the moisture (water)

The conductivity of the moisture also called transmission is the property of a material to transport the moisture in the liquid phase towards its surface from where the moisture is evaporated or diffused. It is actually capillary transport of the water in the continuous thin canals.

The transport of the moisture takes place if the moisture gradient is obtained (the gradient of the moisture during the difference of the temperature 0 °C) or if the gradient of the temperature is obtained (together with the actual gradient of the moisture). During the gradient of the moisture and zero gradient of the temperature the Lykov's law may be expressed by the following equation. That is for the calculation of density of a mass flow of liquid water by transmission.

$$q_{mt,1} = -\kappa_m \cdot \rho_d \cdot \frac{dw}{dx} \quad [\text{kg} \cdot \text{m}^{-2} \cdot \text{s}^{-1}] \quad (1.9)$$

where $q_{mt,1}$ the density of a mass flow of liquid water by transmission $[\text{kg} \cdot \text{m}^{-2} \cdot \text{s}^{-1}]$
 κ_m coefficient of the moisture conductivity during the moisture gradient $[\text{m}^2 \cdot \text{s}^{-1}]$
 ρ_d the volumetric mass density of the material in the dried up state $[\text{kg} \cdot \text{m}^3]$
 $\frac{dw}{dx}$ the moisture gradient $[\text{m}^{-1}]$

If the transport of the moisture takes place even during the gradient of the temperature then the movement in the capillaries is specified by the following equation:

$$q_{mt,2} = -\kappa_m \cdot \rho_d \cdot \kappa_t \cdot \frac{dt}{dx} \quad [\text{kg} \cdot \text{m}^{-2} \cdot \text{s}^{-1}] \quad (1.10)$$

where $q_{mt,2}$ the density of a mass transport of the liquid water by transmission $[\text{kg} \cdot \text{m}^{-2} \cdot \text{s}^{-1}]$
 κ_t coefficient of the moisture conductivity during the temperature gradient $[\text{K}^{-1}]$
 $\frac{dt}{dx}$ the temperature gradient $[\text{s} \cdot \text{m}^{-1}]$

In the building practice, the both gradients take effect together therefore the overall density of a mass flow of the moisture by transmission is expressed as:

$$q_{mt} = q_{mt,1} + q_{mt,2} \quad [\text{kg} \cdot \text{m}^{-2} \cdot \text{s}^{-1}] \quad (1.11)$$

[2] [3]

The transport of the moisture in the brickwork

The transport of the moisture in the brickwork is under the influence of the different physical processes. The following are the main:

- capillary attraction;
- the diffusion of the water vapour;
- condensation of the water vapour and the capillary condensation of the water vapour;
- sorption;
- the transport of the water by other mechanisms;

Capillary attraction

Capillary attraction is an increase of the water in the porous matter as a result of the capillary elevation (capillary lift) above the level of the water surface in

the surrounding if the matter is connected with the moisture. For the lifts, the shape, size of the pores and their connections each other are very important. The higher the moisture is being lifted, the smaller diameter of the capillary is. The average diameter of the capillaries in the brickwork (brick + mortar) is about 0.01 mm. These capillaries can lift the moisture up to 1.49 m. The older buildings have a lot of problems with the waterproofing membranes. The height (1.49 m) corresponds with the practice because these buildings show the wet maps on the facade up to the height of 1.5 m when the waterproofing membranes are missing or are badly done. The development of the capillary attraction was observed for many building materials.

In the practice, the salts are dissolved in the water. These salts increase the surface tension and the weight of the liquid. The real shape of the capillary (grooved walls of cavity) differs considerably from the continuous capillary of the circle diameter and thus even the height of the lift is different.

The water transport in the pores of the brickwork is shown in Fig. 1. The water, which is lifted up in the capillary, does not get through the pore of the large diameter (cavity). Nevertheless, the transport of the moisture is not stopped. The water at the end of the capillary evaporates and diffuses to the next wall of the cavity where the water vapour condenses and in the liquid phase is lifted by the capillaries higher. Except the free water also the water bonded in the thickness of few molecules is lifted up slowly on the walls of the capillaries. Thus on the walls of the capillaries the stiff film is created. This bounded water does not freeze at 0 °C and it is not possible to evaporate it at the temperatures above 100 °C. Under the normal conditions the water changes its phase from the liquid to the gas and thus the evaporation is obtained. The share of the rising water in the construction is dependent on the hydro-geological properties of the subsoil. The gravel subsoil may transport the water only about 100 mm above the groundwater. The subsoil from the clay may transport the water even few meters above. [2] [3]

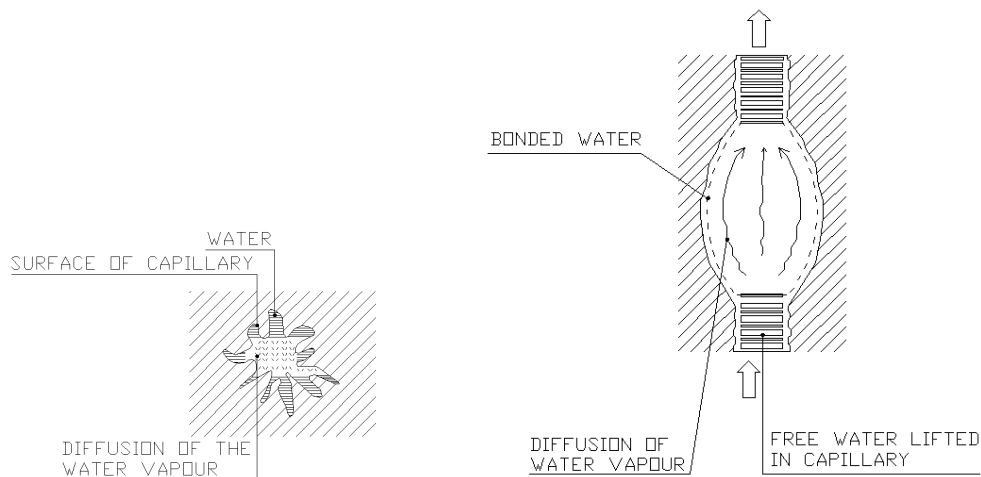

Fig. 1 Sections of the pore with the grooved surface and cavity.

Diffusion of the water vapour

Diffusion of the water vapour occurs due to the differences of the partial pressures of the water vapour in the soils, constructions and in the air between the outdoor and the internal environment. The gas or the water vapour diffuse in every porous matter if the pores are larger than the average free track of the thermal motion of the gas molecules or the molecules of the water vapour. The average free track of the water molecules H_2O is $2.78 \cdot 10^{-10}$ m. There are micro-capillaries or macro-capillaries in the building matters. In macro-capillaries about dimension $d \gg 10^{-7}$ m the capillary condensation does not occur. The water vapour is transported under the law of the diffusion because the free track of the molecules of the water vapour is shorter than the diameters of the porous matter. In micropores about dimension $d \ll 10^{-7}$ m the capillary condensation occurs and the motion of the water vapour is under the law of effusion because the free track of the molecules of the water vapour is either the same or longer than the diameter of a porous matter. The water vapour, which diffuses, moves from the place with the higher partial pressure (higher concentration of the water, higher temperature) towards the place with the lower partial pressure. Under the specific temperature and the pressure conditions, the water vapour may condensate in the matter and construction. The condensation of the water vapour may occur even at the homogeneous and single-layer constructions but its influence is generally neglected. At the more layered constructions, the

condensation is more dangerous and may lead to the degradation of the construction.

The diffusion resistance factor μ defines how many times the diffusion resistance factor of the building construction is higher than the diffusion resistance factor for the same layer of the air (dimensionless quantity). The diffusion resistance represents the transmission of the water vapour through the surface and is given as:

$$d_{\mu} = \mu \cdot d \quad [\text{m}] \quad (1.12)$$

where d the thickness of the layer of the plaster or paints on the facades and their sprays [m],

The overall diffusion resistance of the building construction $d_{\mu\text{overall}}$ is calculated from the sums of the partial diffusion resistances:

$$d_{\mu\text{overall}} = \sum d_{\mu,i} \quad [\text{m}] \quad (1.13)$$

For the ordinary use of the building, it is suitable for the diffusion resistance of a single layer being lower towards the outside. Otherwise the condensation of the water vapour may occur between the layers. For the longest period of the year the motion of the water vapour is from the inside towards the outside of the building. The diffusion of the water vapour may be reversed for a short period of time during the summer, however, that moment has only little importance because the differences between the outside and the inside surface of the brickwork are little. Generally in practice, it is advised that the plaster on the facade should have a lower diffusion resistance than the brickwork and the paints should have a lower diffusion resistance than a plaster. [2]

Condensation

The condensation means that the water vapour is condensed either on the surface or inside an object. The air may contain only the partial amount of the water vapour. If the partial pressure of the water vapour gets a specific maximal

value $P_{v,sat}$ then the air gets saturated with the water vapour. The air gets so-called the dew point. If the additional air gets in thus saturated state of the air, it results in so-called condensation of the water vapour. The condensation is shown as mist, drops of the water (dew) etc. All these cases are called the condensation of the water vapour on the surface. That effect is due to the changes of the temperature. If the temperature on the surface of an object is lower than the dew point, the condensation on the surface occurs. The proportion of the partial pressure of the water vapour P_v and the partial pressure of the water saturated vapour $P_{v,sat}$ is called the relative humidity:

$$\varphi = \left(\frac{P_v}{P_{v,sat}} \right) \cdot 100 \quad [\%] \quad (1.14)$$

The water content in the air is expressed either as [%] or as the absolute moisture [$\text{g}\cdot\text{m}^{-3}$]. The percentage of the air saturation with the water vapour is the function of the temperature. The relative humidity is thus different for the specific value $P_{v,sat}$ at the different temperature of the air.

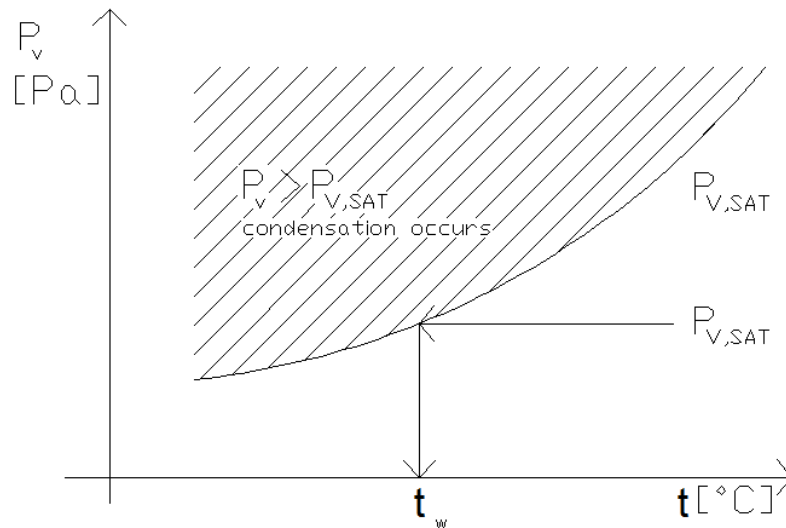

Fig. 2 The dependence of the $P_{v,sat}$ on the air temperature.

Table 2 The dew point. [5]

The air temperature	[°C]	-20	-10	0	10	20	30
Max. amount of the water vapour in the air	[g·m ⁻³]	0.9	2.2	4.8	9.4	17.3	30.3

Table 3 Amount of the water vapour in the air at the different relative humidity. [5]

The relative humidity of the air	Amount of the water vapour in the air [g·m⁻³] during the air temperatures [°C]						
	φ [%]	-20	-10	0	10	20	30
30		0.3	0.7	1.4	2.8	5.2	9
40		0.35	0.9	1.9	3.8	6.9	12
50		0.45	1.1	2.4	4.7	8.7	15
60		0.54	1.3	2.9	5.6	10	18
70		0.63	1.5	3.4	6.6	12	21

The condensation in the capillaries occurs in the pores with the diameters larger than $0.5 \cdot 10^{-6}$ mm because the diameter of the water molecule is 10^{-7} mm. In the pores with the smaller diameters the diffusion of the water vapour does not occur. At the tortuous surfaces with the diameter smaller than 10^{-4} mm the condensation of the water vapour occurs much faster than the condensation on a surface. In the building practice that means if the humid and temperature conditions and the same volume of the pores are achieved then the same two matters will be diversified by the internal moisture content if they have the pores of the different diameters.

The capillary condensation is the reason why the fine porous stones and a cement mortar have the higher moisture content under the same temperature. The places fixed with the cement mortar or the cement plaster in the wet cellars have the higher moisture content for the life time of the construction contrary to the building materials with the larger pores which stay dry. The similar case is at new and old brickwork. The old brickwork has already soaked salts up. That results in the changes of the capillary attraction therefore the brickwork has the higher water content.

[2] [3] [4] [5]

Brickwork chemistry

In the building materials, there are a lot of different chemical reactions. The chemical processes of the degradation occur mostly due to the chemical reactions of less stabilized elements as calcium carbonate CaCO_3 with the solutions of the weak acids. The results of the chemical reactions are salts which have the influence on the properties such as porosity, hygroscopicity, absorption, electrical conductivity, electrical potential etc. On the surfaces of the building materials and constructions, the coloured salts are seen mostly on the boundary between wet and dry part of the material. That effect is called efflorescence. These salts have a negative effect mostly from the aesthetic view on the construction. The efflorescence is shown as spots of powder, crystals or crust on the walls. The salts which are dissolved in the moisture are transported towards the surface of the plaster and after the evaporation of the water these salts may crystallize.

In addition to efflorescence created on the surface, the salts can crystallize even between the layers of the plaster and the brickwork. That is called subflorescence. That case has much more damaging effect for a construction. The important property of the salts is their hygroscopicity. Due to this property the salts increase the amount of the water in the building construction. During the crystallization very high internal pressures occur together with the increases in the volume. The crystallization pressure may be up to 200 MPa. Except the efflorescence and subflorescence even the water may have negative influence as a result of the chemical reactions. According to the chemical properties, the rainwater, groundwater and operative water cause the higher water content in the construction. The water may be classified into three groups:

- 1st group – the acidic water;
- 2nd group – the water which contains sulphates;
- 3rd group – the water with lack of minerals;

[2] [3] [6]

The water transport due to other mechanisms

The shape, polarity and the gradient of an electric field in the wet brickwork are related to the direction, speed, amount of the moisture which is transported in the brickwork and to its chemical composition.

The electric field may be created in the brickwork as a result of the different mobility of ions of dissoluble salts in the rising water which are massed at the border of the evaporation. From here ions penetrate back towards the bottom part of the foundations into the zone with a solution of less concentration. The mobility of cations and anions is different. Therefore the positive pole at the wet brickwork is found out generally in the evaporation zone and the negative pole at the bottom of the brickwork or close to the terrain surrounding.

The other chemical processes may occur when a building material is in the connection with the different material. That may influence electrical voltage between these materials. The material with the higher value of the electrical voltage transfers the electrical voltage to the material with the lower value of the electrical voltage. The metallic parts which are fitted in the wet brickwork and are under the process of the degradation are the sources of the galvanic cell which influence the water transport. These voltages may be even above 1000 mV. The moisture in the brickwork moves even in the cross direction. From the wall with the higher temperature or from the place with the higher partial pressure of the water vapour the diffusion starts towards the place with the lower pressure. Diffusion occurs only in the capillaries and the pores filled with the air and in the capillaries and pores which are not fully filled with the water. The second force which operates in this direction is thermo-osmosis (TO). That phenomena transports the water towards the location with the higher temperature. It operates in the opposite direction than diffusion does under the condition that the capillaries or pores have to be fulfilled with the water. In general, the diffusion occurs mostly in the capillaries and pores with the larger diameters and the thermo-osmosis in the thinner capillaries. These both kinds of the water transport are summed up. The prevailing from the both processes

establishes the final direction of the moisture movement either towards the outer or inner surface. The electric field in the building constructions is influenced with so-called stray currents which are created for example around the electrified rails or in the cities around the trolley-lines. [2] [3]

1.2 The methods for the drying of the building materials

The sanitation of the brickwork means the process which results in a high and a permanent decrease in the water contents both in the constructions which are underground and above the ground. The excessive moisture content in the building construction may be as the result of many factors because the water can penetrate into the building matters in the phase of the liquid and the water vapour in many ways. The following kinds of the water are among these causing the excessive dampness in the constructions:

- rain water;
- capillary water;
- condensed water;
- ground water which causes the pressure;
- the water which penetrates into the construction as a result of the failure of the water installations;

It is important to realize that after the sanitation of the wet brickwork, the water content in the brickwork will not decrease suddenly below the limiting values but the significant decreases should be obtained. The decreases of the water contents depend on the properties of the materials or brickwork, temperature and the relative humidity. This stance of the moisture is called hygroscopic equilibrium moisture content. From the practice, it was found out that to dry out a new built house from the bricks took about two years.

The methods for the sanitation of the wet brickwork according to the norm ČSN P 73 0610 are divided into groups:

1.2.1 Direct methods

- Mechanical;
- Chemical;
- Electroosmotic;
- Magnetokinetic;
- Air-isolating;

1.2.2 Supplementary direct methods

- Hydrophobic mediums;
- Outer paints, spraying and sealing of seam;

1.2.3 The indirect methods

- Drainage of the terrain and landscaping;
- The functionality of the sanitation;
- The adaption of the terrain in surrounding;
- Heating in the building;
- Ventilation of the internal rooms;
- The drying methods;

1.2.4 The supplementary indirect methods

- The system of the sanitation plasters.

The effective sanitation of the wet brickwork consists of a complex design and a combination between both direct and indirect methods. At the present dissertation, I focused on the building materials such as bricks and sandstones and on the direct electroosmotic methods. [1] [2]

1.3 The building matters such as the porous materials

The most of the building materials contain except the solid phase also other two phases in some volumes. The spaces, which are filled with liquid and gas phase and are much smaller in their size than the dimension of an object, are called pores. The matter is defined as porous if the pores in the matter are distributed in the way that the system can be specified in its continuum i.e. the

representative volume of an object can be defined. The water usually fills these pores either partially or fully. The materials contain rarely no water. The water contained in the pores is not chemically pure and contains much or less amount of the different dissoluble matters in it. If these concentrations are low the dissoluble matters may be neglected. The water amount related to a unit of mass or a unit of volume is called the moisture of a matter.

A **mass water content** w is a proportion of a mass of a sample before the drying up w_w and a mass of a sample after the drying up w_d (see the equation 1.1). The volumetric water content θ is a proportion of the volume of the water V_w to the volume of a porous matter V_T from the following equation:

$$\theta = \frac{V_w}{V_t} \cdot 100 \quad [\%] \quad (1.15)$$

- where θ the volumetric water content [%]
- V_wthe volume of the water [m³]
- V_tthe total volume of a porous matter (soil volume + water volume + air space) [m³]

The volumetric water content is preferred when the aim is to quantify the overall amount of the water in the porous matter or to specify the level of the water filled in the pores. Because the specification of the volumetric water content in the building material is quite difficult contrary to a mass water content, the volumetric water content is determined from the following equation:

$$\theta = \frac{w \cdot \rho_s}{\rho_w} \quad [\%] \quad (1.16)$$

- where θ the volumetric water content [%]
 - wa mass water content of a matter [%]
 - ρ_s the volumetric mass density of a matter [kg·m⁻³]
 - ρ_wthe volumetric mass density of the water [kg·m⁻³]
- [2] [5]

1.3.1 The methods for the dewatering of the building matters and the constructions

The moisture problems occur usually at the older buildings in which the waterproof membrane was badly done but also at the new buildings which suffered from the floods etc. The flooded brickwork is wet for a long time even when it seems to be dry on the surface, however, in the brickwork a high water content remains. We can assume that the brickwork may be saturated with the water content about 20 % at the specific weight $1800 \text{ kg}\cdot\text{m}^{-3}$. Then the water content in 1 m^3 of the brickwork is about 360 l-1 m^2 of the brickwork about 450 mm thickness may contain up to 160 l of the water. If we want to estimate time in which the brickwork will be dried up spontaneously to the water content about 3 % the following Cadiergue's equation may be used:

$$T = k \cdot b^2 \quad \text{[days]} \quad (1.17)$$

where T..... the time necessary for the drying up of a building matter [days]
k..... the coefficient of the evaporation (brickwork 0.28) [-]
b..... the thickness of the brickwork [cm]

The spontaneous drying of the brickwork in thickness of 45 cm would take under the normal conditions about 1.5 years. It is necessary to take into account the changes of the seasons mostly wet, rainy days and thus the time for the drying is prolonged. At the brickwork with the thickness of 60 cm the duration for the drying under the optimal conditions would be about 3 years.

The speed of the evaporation is therefore influenced by many factors. Except of the speed of the air flow also the relative humidity and the air temperature are significant. During the summer the relative humidity is higher than in the winter and the spontaneous evaporation is thus much slower. The drying is moreover influenced by the air permeability of the surface of the brickwork. The materials with lower air permeability as some paints, ceramic facing (bath-rooms, kitchens

etc.) but also the cement plasters slow down or stop the spontaneous drying process. The evaporation coefficient for the cement plaster is 2.5. In the practice, that generally means the stop for the drying process. [2]

Equipments for the drying under the influence of the hot air

The drying process with the heaters

The water saturated wall gets warmer due to the influence of the circulating air from the heaters. In addition, the relative humidity of the circulating air is the lower (positive effect), the colder air from the outside gets into the system. The wet wall is gradually warmed up and the circulating air enables faster exhaust of the water vapour from the wet brickwork. The speed of the drying or the final drying depends on the temperature with which the wet wall is being warmed up. Another factor is the intensity of the circulation and the duration which is necessary for the wall being warmed up. The last factor is the humidity of the circulating air. The heaters belong to the easiest option for the drying of the building constructions. At the present time, the new electrical heaters may be also classified to this group.

The possible use of the heaters:

- The rooms where the use of the condensing dehumidifiers is not appropriate the use of the heaters is a suitable option;
- spaces without the possibility to close (halls etc.);
- too big rooms;

The recommendations for the proper use of the heaters:

- The heaters are not allowed to radiate on the brickwork in the distance less than 70 cm to be efficient;
- The ventilation to the outer space is necessary during the drying process;
- It is not recommended to use heaters together with the condensing dehumidifiers with the open fire because during the drying the water vapour is created and accumulated in the closed room which is being dried up;

- The sudden decrease in the humidity has to be checked because under some circumstances that might lead to the failure of the static;
- The places, where the electrical and water installations are, have to be dry with the care especially parts where the water in the plastic pipes is;

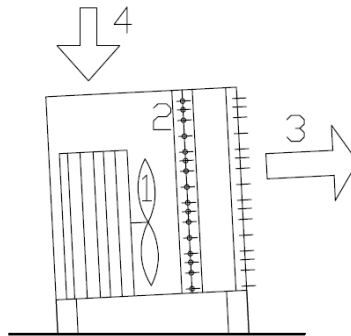

Fig. 3 Figure of a heater: 1 – a fan, 2 – electrical heater, 3 – a hot air, 4 – a cold air.

Radiation panels

The drying process with the radiation panels

During the convective heating, the air is being warmed with the heaters. Then the hot air transmits the heat by the heat flow to the surfaces of the warmed objects (walls, furniture etc.). From the energy point of the view, the radiate part is minimal. During the heating with the radiation panels this proportion is reversed. It means that the radiation do not warm the air but freely passes through it. The sharing heat is mostly due to the radiation. The radiation flow after the fall on the objects (wall, floor, furniture) is partially reflected about 15 % and its 85 % is absorbed in the objects on which the radiation felt. From this point, the radiation energy is transformed in the heat energy and the objects are being warmed up. This principle is called infra heating.

The possible use of the radiation panels:

- The use of the panels is suitable for the heating of any spaces;
- The lower costs of the energy in comparison with the convective heating;
- To reduce the possible condensation on the wall surfaces because the air humidity does not increase significantly;

- The wall from the panels and a concrete wall - it is possible to dry up a concrete wall about 30 cm of thickness and 1.3 m of height which is fully water saturated after 24-48 hours when an appropriate radiation panel is used;

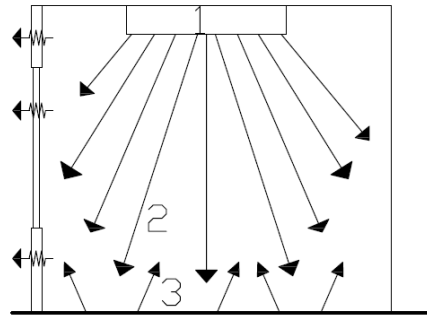

Fig. 4 Radiation panel: 1 – a radiation panel, 2 – a radiation flow, 3 – a reflected radiation flow.

The condensing dehumidifiers

The drying process with the condensing dehumidifiers

During the use of the dehumidifiers, the condensation of the moisture which is contained in the air occurs therefore it is necessary to keep rules for their use otherwise the efficiency of the dehumidifiers might be decreased. The moist air gets into the dehumidifier where the air is cooled. The condensed water flows into the storage or directly into the drainage.

The possible use of the dehumidifiers:

- To dry out cellars, halls and archives after floods;
- To dry out wet rooms and the buildings without facilities;

The recommendations for the proper use of the dehumidifiers:

- It is necessary to remove any dirt, salts from the surface. If the plaster is deteriorated it has to be removed before the drying process;
- The dehumidifiers have to be used in the right quantity because there are many dehumidifiers with the different capacities. If the quantity of the dehumidifiers is not sufficient, the condensation may occur on the walls and windows. If the dehumidifiers were more, the more energy would be consumed;

- The access of the air from the different rooms or outside should be avoided;
- To cover every gap in the drying-out room;
- The temperature of the air in the drying-out room should be kept between 20-30 °C (the higher temperature, the quicker evaporation of the moisture from the brickwork);
- The ventilation is not allowed. The access to the room is allowed only to empty the storage with the water;
- The dehumidifiers should be kept running in the room until the water content decreases to the state of 3 % called as a very low level of the moisture. Then it is possible to move the dehumidifiers into the other room. The moisture may be checked with the humidity meters;

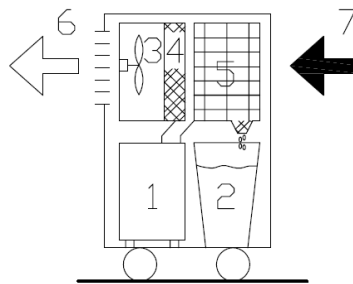

Fig. 5 A figure of a dehumidifier drier: 1 – a compressor, 2 – a storage for the water, 3 – a fan, 4 – a condenser, 5 – an evaporator, 6 – dry air, 7 – moist air,

Adsorptive dehumidifiers

The drying process with adsorptive dehumidifiers

Adsorption is a property of the solids to concentrate gases and liquids on their surfaces. The adsorption is a physical process which occurs on the interfaces of the liquid–solid phase or gas–solid phase. During this process the concentration of either gas or liquid compounds appears on the surface of an adsorbent (solid substance). The adsorptive dehumidifiers draw the water directly from the absorbed air on the basis of the hygroscopic adsorption. The air for the dehumidification gets into the system with a fan through a filter and continues over the slowly rotating sorption wheel where the water molecules are bonded to a sorbent etc. gelatinous silica gel.

The possible use of the dehumidifiers:

- To dry out the buildings and the storage spaces;
- To dry out the places which have already been dried to the very low moisture level;

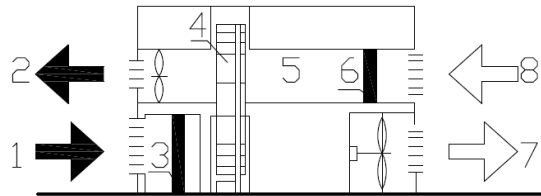

Fig. 6 A figure of the adsorptive dehumidifier: 1 – an input of the process air, 2 – an output of the regenerative air, 3 – a filter for the input air, 4 – a adsorptive rotor, 5 – heater of the regenerative air, 6 – a filter of regenerative air, 7 – an output of the dehumidified air, 8 – an input of the regenerative air,

Ventilation–windows, doors

The drying process with the ventilation

The ventilation is one of the way how to dry out a room. It is based on the natural air flow through the open windows or doors. To speed-up the ventilation, different types of fans may be used.

The possible use of the ventilation:

- To dry out the rooms;
- To regulate the stuffy air–the air exchange;
- To regulate the temperature;
- The air is needed for burning boiler, stove etc.;

Two main types of the ventilation:

a) Natural ventilation

- ventilation in joints,
- ventilation through windows, doors,
- ventilation in shafts,

b) Forced air ventilation

- the equipment for the ventilation,
- air conditioning,

The microwave drying

The drying process with microwaves

The principle of microwave drying is based on the vibrations of the water molecules when the microwaves are applied into the brickwork. This movement and the friction generate the heat energy. This generated energy transforms the water molecules in the water vapour which is ventilated. The vibration of the water molecules is the primary action in this process. The water molecules are able to get rid of their energetic potential which bonds them to the capillaries in the building materials and makes them impossible to evaporate. It is not possible to get this stance only due to the water heating. The pressure of the water vapour is created from the vibration of the water molecules under applied microwaves. That pressure comes from the middle of a material and continues to the outer surface of a material but at the basement only to the interior (slower process). The microwaves cause the heat of an object in its whole mass and that is the main difference against the heaters. The dependence of an absorbed amount of the energy is on the properties of the materials and the characteristics of the radiation such as the frequency of the microwave field, permittivity, dielectric dissipation factor and the intensity of an electric field in the material. For the drying process of the materials and for the removal of the pests in it, the frequency 2450 MHz is generally used. This corresponds to the wave length of 12.5 cm. This frequency is chosen because it influences the water molecules the most. The duration of the drying depends on the factors such as the wall thickness, type of a material and the level of the water content in the brickwork.

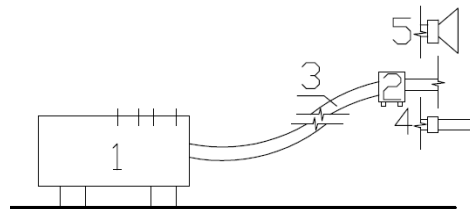

Fig. 7 A device for drying with microwaves 1 – microwave supply, 2 – a generator of microwaves, 3 – a waveguide antenna, 4 – a sticked shaped antenna, 5 – a horn shaped antenna,

The possible use of the microwave drying:

- To dry out quickly the buildings after floods;
- To dry out wooden parts;
- To remove pests and fungi;
- To dry out only the specific parts of the building constructions;

The electroosmotic drying

The drying due to electro-osmosis is described in the chapter (3 ELECTROKINETICS)

[2] [7] [8] [9] [10] [11]

2 SALTS

Soluble salts are considered as the most common source of the building damage in the building constructions mainly in the lower parts of the buildings. The sources in the building matters are different. Types and the amount of the salt concentrations in the building matters depend on the physical properties of the salts, the used materials, the amount of the moisture in the material, the way of its contamination and on many other factors related to the environment.

2.1 Transfer of the salts and the moisture

- To understand how and which mechanism of the damage is created;
- To choose and to design the right intervention and to estimate the efficiency of the outcome;
- To predict the future evolution of the damage;

The final distribution of the salts balances and depends on the three processes:

- The rate of the moisture loss through the evaporation;
 - The rate of the moisture supply by the capillary flow;
 - The rate of ion back diffusion due to the concentration gradient established within the salt solution;
- [6]

2.2 Transport of the moisture and ions

There are two main types of the transport mechanisms for the salts induced by the water in the matters-diffusion and advection. In the first stage of the drying of the building matters, the advection takes a major role. It means that the ions accumulate at the surface of an object during the drying from the beginning and their concentration increases following the water evaporation from the surface. The first stage is in the liquid phase. That evaporation process occurs until the amount of the moisture supplied to the surface is higher or equal to the amount of the evaporated moisture. The drying phase is influenced by the environmental conditions such as the relative humidity, temperature, air speed and many

factors such as the porosity of the material, the area and the surface of the material and the level of the saturation in the pores. [6]

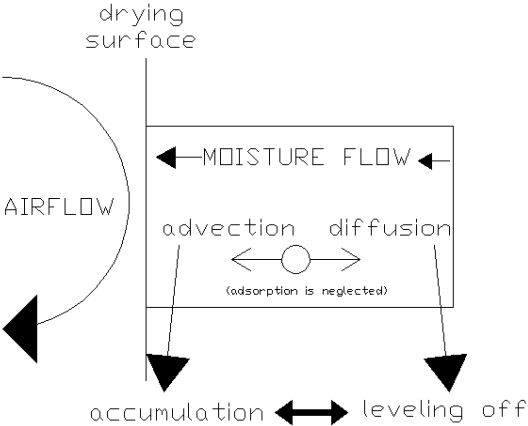

Fig. 8 A scheme of one-sided drying sample which is saturated with a salt solution.

The diffusion as the second main transport mechanism is influenced mostly by the porous structure in the connection with the capillary forces. The moisture flows preferentially into the micropores due to the pressure gradient. That action results in a lack of the water inside the macropores and thus the isolated clusters are created. The discontinuity of the moisture flow occurs and the moisture transport is provided through the vapour phase. The isolated clusters are evaporated due to the high difference of the relative humidity between the air around the clusters and the relative humidity at the surface of the matter or a material. During the drying process, the air moves into the largest pores, where the capillary pressure (P_c) is the lowest. The following equation describes that process as:

$$p_c = \frac{2\gamma}{r_m} \cos(\varphi) \quad [\text{Pa}] \quad (2.1)$$

- where r_m a radius of the pore [m]
- γthe tension of the surface - liquid/vapour interface
[N·m⁻¹]
- φ the contact angle - liquid/air and liquid/soil interface
[°]
- ρ_wthe volumetric mass density of the water [kg·m⁻³]

The following equation describes the moisture transport during the drying process. The gravity is neglected. The mechanisms as the liquid flow and the diffusion of the vapour are in the combination called as the moisture diffusivity. The following model does not include the moisture transport due to the salt gradient.

$$\frac{\partial \theta}{\partial t} = \frac{\partial}{\partial x} \left(D(\theta) \frac{\partial \theta}{\partial x} \right) \quad (2.2)$$

where θthe volumetric liquid moisture content [$\text{m}^3 \cdot \text{m}^{-3}$]
 $D(\theta)$ the isothermal moisture diffusivity [$\text{m}^2 \cdot \text{s}^{-1}$]

In the following equation the influence of the salts is included:

$$\frac{\partial (\theta_c)}{\partial t} = - \frac{\partial}{\partial x} \left(\theta (D_c \frac{\partial c}{\partial x} - cU) \right) - R \quad (2.3)$$

where cthe concentration of ions in the water [$\text{mol} \cdot \text{l}^{-1}$]
 D_cthe diffusion coefficient of the ions in the moisture inside the porous medium [$\text{m}^2 \cdot \text{s}^{-1}$]
 Uthe velocity of the water [$\text{m} \cdot \text{s}^{-1}$]
 Rthe rate of the crystallization [$\text{mol} \cdot \text{l}^{-1} \cdot \text{s}^{-1}$]
 θ_c the total amount of the salt content in the porous matter (material) [12] [13] [14]

As it has been written two main mechanisms the advection and diffusion are responsible for the moisture transport connected with the salt transport. The Fig. 9 shows these two mechanisms during the drying of a sample of the fired-clay brick contaminated with the 3 M(NaCl) solution. The measurements of ions were conducted with the nuclear magnetic resonance. From the beginning of the experiment, a quick and a high increase of ions at the surface of the sample is seen. That quick increase at the surface was due to the advection—the first stage. When the concentration of ions at the surface gets its saturated value the additional advection may lead to the crystallization—the crystals may be seen on the surface. When the surface changes due to the salts, efficiency of the

advection decreases. Diffusion (second stage) starts its importance from that point. The concentration of ions is being levelled off in the cross section of the whole material during the next days until the concentration of ions in the sample of brick gets saturated value 6 M. The relation between the advection and the diffusion may be expressed as the Peclet's number P_e :

$$P_e \equiv \frac{UL}{D_c} \tag{2.4}$$

where L the length of a sample [m]
 D_cthe coefficient of ion diffusion [$m^2 \cdot s^{-1}$]
 Uthe velocity of the water [$m \cdot s^{-1}$] [6] [12] [14]

If the $P_e \ll 1$ the diffusion prevails. If the $P_e \gg 1$ the advection dominates. From the Fig. 9 it is clear when the diffusion and advection are dominant.

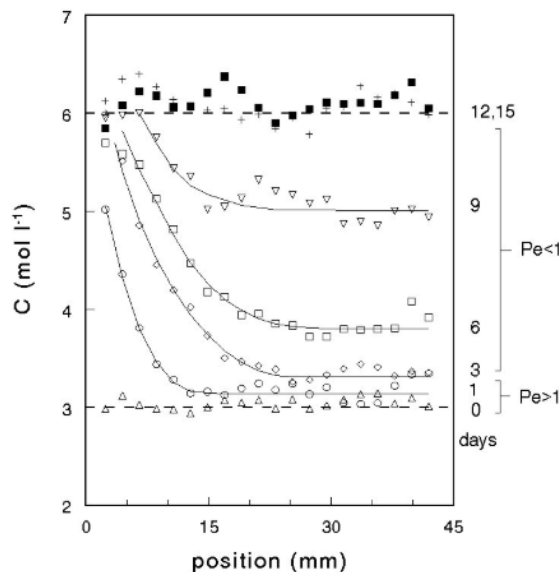

Fig. 9 The profile of NaCl concentration measured during the drying of a fired-clay brick sample of 45 mm length after 0, 1, 3, 6, 9, 12, and 15 days. The drying surface is at 0 mm. [6] [12]

2.3 The viscosity – the property of a solution

The viscosity of the liquid is a very important property and may influence the capillary flow significantly. The accumulation of the ions which results in the high concentration at the surface may slow down the capillary flow and the

evaporation rate which was demonstrated in the study [15]. It was shown that the different types of salts influence the capillary flow differently. [6] [12]

2.4 The structure – the influence of the structure on the evaporation

It was observed that the damage by salts in the material structure may be transported from one layer into the other by the advection. The different size of the pores is important because in the pores of the small sizes (fine pores) it was proved that these held the moisture longer due to the higher capillary pressure. That results in the drying of the larger pores firstly. [6] [16]

2.5 The structure – the influence of the relative humidity

Another important condition for the water flow is the relative humidity which may also influence the crystallization significantly. The following equation expresses the connection of the surfaces air/material interface:

$$q_v = \beta(h_a - h_l) \quad (2.5)$$

where βthe mass transfer coefficient [$\text{kg}\cdot\text{m}^2\cdot\text{s}^{-1}$]
 h_a the relative humidity of the air [%], [-]
 h_lthe relative humidity of the air/liquid inside the porous material [%], [-]

Nevertheless, the β coefficient may be influenced by many factors such as the velocity of the air, the thickness of the drying surface, the porosity of the material etc. If the salts are presented in the moisture, the situation becomes even much more complicated. The relative humidity is one of the most important factor for the crystallization. [6] [12]

2.6 The damaging effect of the crystallization

The salts can cause serious damages in the building constructions. The damages are due to the changes in the mechanical and physical properties of the salts in the building matters. During the changes of the salt properties, the high

pressures occur. These pressures are much higher than the tensile strength of the building materials. Generally, the main responsible mechanisms for these damages in the matters caused by the salts are:

- the crystallization pressure;
- the hydration pressure;
- other theories exist; [17]

2.6.1 The crystallization pressure

The salts have different chemical and physical properties. Their combinations and the salt mixtures can be created. In addition, the different salts and their mixtures crystallize at the different relative humidity. Thus it is very difficult to predict the crystallization. The mathematical model for the crystallization pressure was defined by Correns. It was proved that the crystals of the salts had to be in a supersaturated state to derive the crystallization pressure [18]. The following equation describes the pressure:

$$P_c = \frac{nRT}{v_c} \ln\left(\frac{C}{C_o}\right) \quad [\text{Pa}] \quad (2.6)$$

- where
- P_c the crystallization pressure [Pa]
 - C the saturation concentration inside the pore [$\text{mol}\cdot\text{l}^{-1}$],
 - C_o the concentration of the ions in the bulk solution [$\text{mol}\cdot\text{l}^{-1}$]
 - R the gas constant [$\text{J}\cdot\text{mol}^{-1}\cdot\text{K}^{-1}$]
 - T the thermodynamic temperature [K]
 - v_c the molar volume of the salt [$\text{m}^3\cdot\text{l}^{-1}$]
 - n the number of ions in the salt

In the recent years, this equation has been only refined and it was found out that the equation was appropriate only for calculation of the high pressures in very small pores (< 10 nm). Thus the problematic of the crystallization at the historic buildings and building materials is very difficult because the historic buildings are built with the different materials which may contain even larger

pores. Moreover the building constructions are built from many layers of the materials and the different salts have different properties in relation to the crystallization pressure. Therefore the mathematical model which might solve the problematic of the crystallization pressure has not been found out so far.

2.6.2 The hydration pressure

The crystallization of the salts may be repeated many times due to the changes of the relative humidity. During the crystallization and re-crystallization a low hydrate may be changed to the higher hydrate in conjunctions with the high pressures called as the hydrate pressures [19]. [6] [12] [17]

2.6.3 Other theories

In the previous study it was proved that the crystallization pressure was dependent on the type of the salt. Not every salt can create such a high pressure to cause the damage in the material. For example the sodium chloride does not create such a high pressure [20]. The pressure depends on many factors such as the material porosity, RH, the water content and many others. [17]

2.7 The climate and its influence on the salt formation

The influence of the climate on the salts is a crucial factor. The different types of the salts and their formations crystallize due to the different relative humidity. Table 4 shows the deliquescence points of some salts.

Table 4 Deliquescence point for some salts. [17]

	The deliquescence point [% RH]
$\text{MgCl}_2 \cdot 6\text{H}_2\text{O}$	33
$\text{Ca}(\text{NO}_3)_2$	50
$\text{NaNO}_3 \cdot 4\text{H}_2\text{O}$	74
NaCl	75
Na_2SO_4	82
$\text{Na}_2\text{SO}_4 \cdot 10\text{H}_2\text{O}$	91
$\text{CaSO}_4 \cdot 2\text{H}_2\text{O}$	100

The increases in the relative humidity from below to above the deliquescence point cause the dissolution of the salts which are precipitated contrary to the decreases in the relative humidity from above to below the deliquescence point where the precipitations of the salts occur. The changes of the relative humidity is only a partial condition for the dissolution/precipitation effect. The other important factor is the temperature because some types of the salts are dependent on the temperature therefore the prediction of the salt behaviour is complex and complicated. [17]

2.8 The damaging concentration related to the salt anions

Currently, only few countries have a threshold for the limits of the concentrations of the most common salt anions. Critical amount of the salts in the building matters are different in accordance with the type of the material, characteristic of the salt, amount of the moisture etc. Generally, to find out the limiting amount of the salts in the building construction is difficult. In the present dissertation, the threshold values according with ÖNORM 3355-1 [21] are taken into account. The used thresholds are related solely to the anions of chlorides (Cl⁻), nitrates (NO₃⁻) and sulphates (SO₄²⁻). [17]

Table 5 Threshold values for chloride anions from ÖNORM 3355-1. [21]

anion	water content w [%]	[g·kg ⁻¹]	solution
chlorides (Cl ⁻)	< 0.03	< 0.3	without risk
	0.03-0.10	0.3-1.0	individual evaluation necessary
	> 0.10	> 1.0	active salt removal is advised

Table 6 Threshold values for nitrate anions from ÖNORM 3355-1. [21]

anion	water content w [%]	[g·kg ⁻¹]	Solution
nitrates (NO ₃ ²⁻)	< 0.05	< 0.5	without risk
	0.05-0.15	0.5-1.5	individual evaluation necessary
	> 0.15	> 1.5	active salt removal is advised

Table 7 Threshold values for sulphate anions from ÖNORM 3355-1. [21]

anion	water content w [%]	[g·kg⁻¹]	solution
sulphates (SO₄²⁻)	< 0.10	< 1.0	without risk
	0.10-0.25	1.0-2.5	individual evaluation necessary
	> 0.25	> 2.5	active salt removal is advised

3 ELECTROKINETICS

Electrokinetics may be also called electrokinetic remediation. These methods offer a high efficiency in the decontamination of the fine pores soil. When an electric field is applied across the porous material, the movement of ions in a solution starts. Minimally two electrodes are needed for such ion transport (see Fig. 10). Due to thus obtained electrokinetic process, radio-nuclides, heavy metals and other organic compounds or their mixed inorganic matters can be removed from the different porous matters. The method for the remediation of the soil was described in the previous studies [22] [23] [24] [25].

Electrokinetic processes consist of two main parts: electromigration and electro-osmosis. The following chapters are related to the use of the electrokinetic phenomena in the porous building materials.

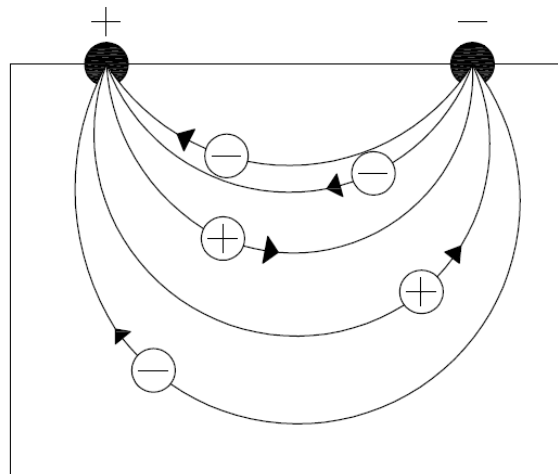

Fig. 10 Scheme of migration of ions towards the electrodes of the opposite polarity under an influence of electric field.

3.1 Electromigration

The transport of the dissolved salts is connected with the movement of the moisture. When an electric field is applied to a moist porous material the electric field is carried by ions in the pore solution. This process is called electromigration. Electric current is carried by electrons in the metallic electrodes. Processes, which transform electric current carried by electrons to the current carried by ions and vice-versa, are called “electrode processes”.

These processes are dependent on the material of the electrodes, the applied potential and on the type of the electrolyte solution. Oxidation and reduction processes will occur at the anode and cathode, respectively. In addition to these processes, around the electrodes, where the dried place is, the ions can precipitate. Electromigration was described in the previous study [26] by the following equation:

$$D_o = \frac{k_B T u L}{F |z|} \ln \left(\frac{C}{C_o} \right) \quad (3.1)$$

where k_B the Boltzmann constant [$1.3807 \cdot 10^{-23} \text{ J} \cdot \text{K}^{-1}$]
 T the temperature [K]
 u the ionic mobility [$\text{m}^2 \cdot \text{s}^{-1} \cdot \text{V}^{-1}$]
 L the Avogadro constant [$6.022 \cdot 10^{23} \text{ mol}^{-1}$]
 F the Faraday constant [$96485 \text{ C} \cdot \text{mol}^{-1}$]
 z the unit charge

Electromigration in the bricks was further described in the study [17].

3.2 The problems during the electromigration

When an electric field is applied into the brickwork the transport of the current by ions may be interrupted from the different reasons. One of the reasons might be the stray current effects. There are many building which have some metallic parts in the walls. These parts may be responsible for those interruptions. Therefore some forms of the protections are necessary. The following solutions are given:

The cathodic protection:

- The connection with the metal which has in the environment spontaneously more negative potential than the protecting potential of the metal which is aimed—the anode is given up;
- The connection of the protective metal with the negative pole of the direct current—the outer direct current supply;

Others:

- The changes of the metallic parts for resin-anchoreess;
- Electrical isolation around discontinuous metallic parts;

3.3 The migration of the ions and their velocity under an applied electric field

The velocity of ion migration varies in different materials. Generally, if the ion concentration is the same, the ion with the highest velocity is transported firstly. From the experiments with the porous bricks the following velocities were calculated:

Table 8 Mobility for the relevant anions [$u/10^{-8} \cdot m^2 \cdot s^{-1} \cdot V^{-1}$]. [27] [28]

	OH^-	Cl^-	$^{1/2}NO_3^-$	$^{1/2}SO_4^{2-}$	$^{1/2}CO_3^{2-}$
Mobility of ions	20.64	7.91	5.49	4.15	3.73

Table 9 Mobility for the relevant cations [$u/10^{-8} \cdot m^2 \cdot s^{-1} \cdot V^{-1}$]. [27] [28]

	H^+	K^+	Na^+	$^{1/2}Ca_2^+$	$^{1/2}Mg_2^+$	$^{1/2}Fe_2^+$	$^{1/3}Fe_3^+$
Mobility of ions	36.23	7.62	5.19	3.09	2.75	2.74	2.39

Migration of ions is related to the one valence electron which is transported between the electrodes. If the ions are dissolved in the electrolyte the order of the electromigration is following:

Anions:

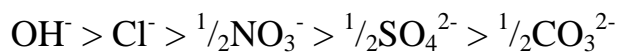

Cations:

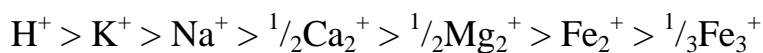

Nevertheless, the velocity of anions is limited by the velocity of the fastest cation because the neutrality has to be maintained. In the previous research, it was found out that the velocity for Na^+ was lower in a $NaCl$ solution than in a Na_2SO_4 due to the different velocities of Cl^- and SO_4^{2-} . [17]

3.4 Electro-osmosis

After the application of the voltage into a fine-grained or porous material, ions which are in the solution (electrolyte) start to move by the electrical migration and this migration induces movement of the water in the direction to the positive or negative electrode in relation to the whole charge of the interface of a fine-grained or a porous material. In the case of the bricks, the internal surface has a negative charge. The internal surfaces will be polarized with the charges of the opposite polarity and then the chemical equilibrium will be maintained (see Fig. 11). Ions with the same charge as the charge of the internal surface are called co-ions. Opposite ions are called counter-ions. From this equilibrium double electric layer is created. Co-ions are presented much less in this double layer than the counter-ions. Application of the voltage causes the movement of the counter ions and co-ions towards the electrodes with the opposite signs. Because counter-ions are dominant against the co-ions inside the double electric layer, the water molecules around the counter-ions are dragged to the cathode electrode together with the counter-ions [29].

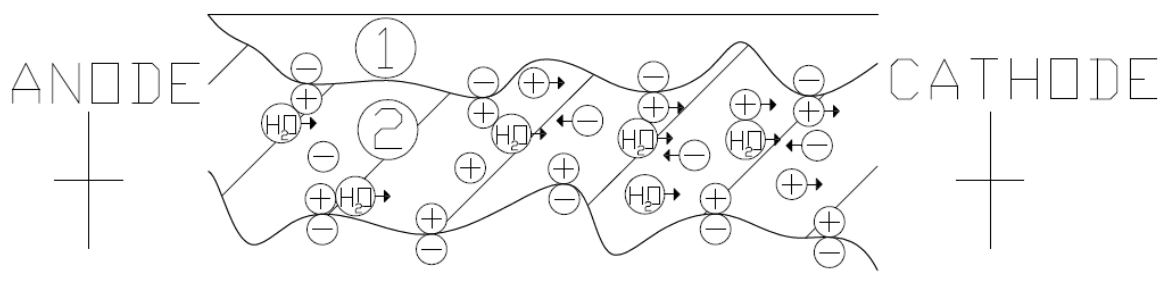

Fig. 11 The scheme of the internal surface of a porous material (brick). 1 – the internal surface (negative charge in the case of the porous bricks); 2 – the solution (positive ions – counter-ions) and (negative ions – co-ions), hatch – a solution (electrolyte).

The water movement towards the cathode was seen in most of the porous materials. The following theory from Helmholtz and Smoluchowski describes the velocity of the water movement as:

$$U = \sigma \cdot \frac{\delta}{\eta} \cdot \frac{\Delta E}{\Delta L} \quad (3.2)$$

where σ the surface current density [$C \cdot m^{-2}$]
 δthe thickness of the electric double layer [m]
 η the viscosity [$kg \cdot m^{-1} \cdot s^{-1}$]
 $\Delta E/\Delta L$the size of the applied electric field per area [17]

The surface current density depends on the used material. In the experiments with the bricks the surface current density varied between bricks of the different colours [17]. The thickness of the double layer is dependent on the ionic concentration in the electrolyte. The increase in the electrolyte concentration results in the decrease in thickness of the double layer. The viscosity is connected to the compound of an electrolyte in the pores.

3.5 Electrode processes

The current transported by electrons is changed to the current carried by ions in the pore solution (electrolyte). The chemical processes occur at the electrodes. If the inert electrodes are used in the experiment and the low concentration of ions is obtained in the solution (electrolyte) the following primary reactions occur:

Cathode (electrolysis)



Anode (electrolysis)



Chloride oxidation



Reactions (1) and (3) influence the changes of pH. In the case of the inert electrodes covered with the platinum (laboratory experiments in the presented work) reactions (2) and (3) will prevail at the anode. The creation of H^+ ions at the anode (3) results in the acidification contrary to the reaction at the cathode

(1) where the OH⁻ ions are created. The base front is thus developed. The amount of the acid and base fronts is dependent on the duration and the total current passed through the set up. If the used electrodes are non-inert and there is a presence of chlorides other reactions may occur. That may result in the changes of the colour around the electrodes together with the corrosion. There may be created plenty of other reactions in the vicinity of the electrodes. The examples of reactions which may occur:



3.6 The changes of the matrix

The pH of the material or structures changes during the lifetime. The development of H⁺ ions from the electrode processes results in the gradual decreases in pH. Generally, the acidification is unwanted in the structures because it causes the deterioration. Therefore it is necessary to hinder this acidification of the brickwork and the structures during the treatment (dewatering and desalination). Thus the setup for any treatment should have the possibility to control the pH during the duration of the treatment. The electrokinetics allows this possibility of the controlled pH. [17]

3.7 The dependence on the material

The transport of the ions in a porous material is dependent on the factors such as the distribution of the pores, their structure and site. The degrees of the saturation and the concentration of ions in an electrolyte are also important. The factor of the traditional diffusion in the liquid was found out 10⁵ higher than in a saturated brick. The ion transport that is in a porous material under steady-state conditions is called effective diffusion (D_{eff}). It is suggested that there is a link between the traditional diffusion (D_o) that is actual in a free solution and the second kind of diffusion called effective diffusion (D_{eff}) that is in a porous material.

$$D_{eff} = p \frac{\varepsilon}{\tau} D_o \quad (3.3)$$

where p..... the porosity of a material [%]
 τ..... the tortuosity factor [-]
 ε..... the constrictivity [-]
 D_{eff}..... the effective diffusion [m²·s⁻¹]
 D_o..... the traditional diffusion [m²·s⁻¹] [17]

3.8 The change of the conditions during the experiments

There are many conditions which may influence the efficiency in the laboratory scale experiments aimed at the migration of the ions. One of the most important is the applied current strength. The strength of the applied current was optimized for the highest removal efficiency of the heavy metals from the fly ashes. The laboratory optimization is dependent on the type of the material or the mixture and the aim of the treatment. Such increase in the constant current strength results in the increase of the voltage based on the Ohm's law ($U = R \cdot I$). This increase seems to be a limiting factor for the removal of the salts or any ions due to the electromigration. The problematic with the high resistance is discussed in the dissertation (read the experimental part). [17]

4 OSMOTIC METHODS - THE USE IN PRACTICE

During the moisture flow through the capillary, the double electric layer is created on the interface between the capillary and the liquid. For the sanitation practice, the positive zeta potential and the positive particles close to the surface of the capillary are important. If the direct current is applied into the layer the positive charges start to move together with the water molecules towards the cathode. The drying methods based on the electroosmotic principle are technically suitable for every type of the material and constructions with the porous structure in which the water movement occurs due to the capillary forces.

4.1 The passive electro-osmosis

The setup of the electrodes consists of the electrodes built in the moist brickwork and the electrodes underground. The electrodes in the brickwork and in the soil are from the same material (copper, steel) and these are connected in a short distance. The electric field during the passive electro-osmosis is created between the steel electrodes put in the mortar bed (pH = 12-14) and the steel grounding electrodes in the soil with the pH around 6. The created voltage is small (0.2–0.5 V) and takes place until the point in which the mortar around the electrodes in the wall gets carbonized. The durability of the setup is between 1–3 years. Moreover the installation is sensitive to other induced voltage which may change the polarity of the electrodes and thus the moisture gets higher amount.

[4]

4.2 Galvano-osmosis

The galvano-osmosis differs from the passive electro-osmosis in the electrodes that are made from the materials with the different conductivity. These two materials and the moisture in the brickwork create the voltage supply resulting in the desirable electroosmotic water transport. The intensity of the electric current is very low, the electrodes undergo corrosion, the interaction is caused by the stray currents and induced voltage from the traction. That results in the shorter durability.

[4]

4.3 Use of the passive electro-osmosis and galvano-osmosis

The passive electro-osmosis and the galvano-osmosis are not suitable methods especially due to the short durability and therefore these methods are not used at the present time any more. [4]

4.4 The active electro-osmosis

The problems of the passive electro-osmosis are solved with the active electro-osmosis (AEO). At the active electro-osmosis, an electric field from the power supply forces directly against the capillary water. The electric field in the brickwork is created with the gradient which cannot be interrupted with the induced voltage from the surrounding.

At the setup of AEO, the electrodes built in the brickwork are connected to the positive pole of the power supply and the negative pole to the grounding electrodes. The positive electrodes are electrochemically influenced and their operating life depends on the anodic dissolution of the material from which the electrodes are made. At the present time, the use of the electrodes made from the modified carbon are the most common.

The electrodes in the brickwork are set up mostly as the strips conductors either on the one or both sides. These conductors are called strips electrodes and may have a different width. These electrodes may be set up also in the form of the conductive paints or the plastic conductive strips (both with the admixed carbon). Other types of the electrodes have stick or bow shapes. These are put in the holes in the brickwork drilled before. The solutions are shown in the Fig. 12.

[4]

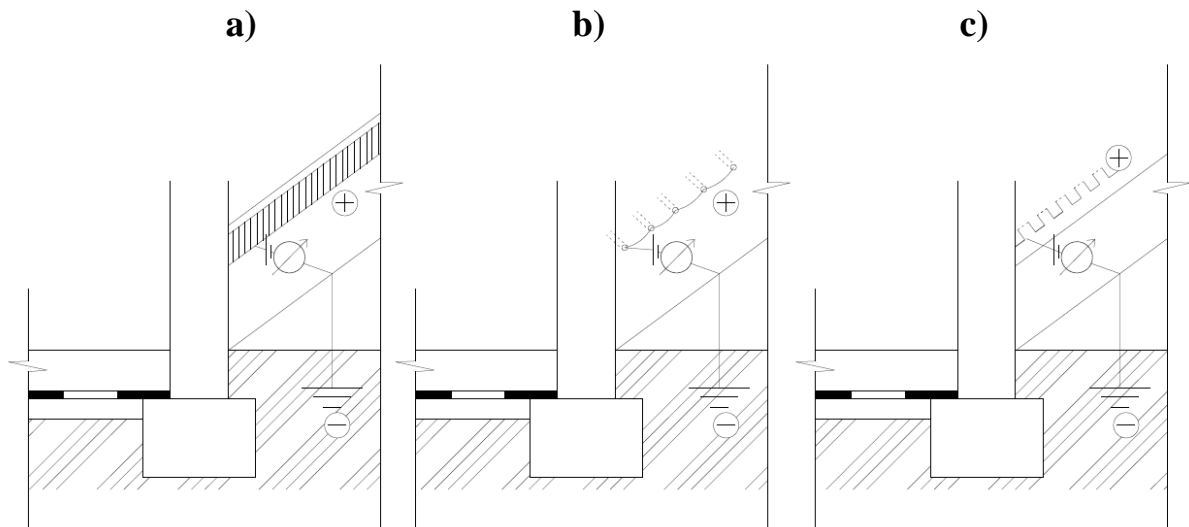

Fig. 12 The variation of the electrodes in the brickwork. a) stripe electrodes, b) stick electrodes, c) bow electrodes. [4]

5 DRYING AND DESALINATION OF THE MATTERS UNDER AN APPLIED ELECTRIC FIELD

5.1 The use of electrokinetics for the drying and the desalination of the matters

At the present time, the electrokinetics is used as the advanced option for the dewatering and the desalination of the building constructions. That technique in the field of the civil engineering was tested for the dewatering and desalination of many buildings materials. It is necessary to do an initial exploration of the construction of the interest. If some metallic parts are found out in the construction it is necessary to protect this parts (read chapter 3.2) otherwise the technique may not be efficient enough.

5.2 Poulticing

This term "poulticing" has origin in medicine, where poultices such as different mixtures were placed on the body in order to reduce pneumonia or to reduce pain.

5.2.1 Classic poulticing

At the present time, the use of the poultices is the most common method for the desalination of a brickwork. For the purposes of desalination, poultices are applied on the outer side of the brickwork. The consistency of the poultices may be different such as mixture of cellulose, clay etc. The desalination is obtained by (i) diffusion of salts into the poultices in consequence of different concentrations and/or by (ii) advection in consequence of evaporation of vapour from the poultice into the surrounding and by the following capillary transport of salts from the object into the poultice. The desalination by diffusion is a very long process, which may take weeks, months to obtain the desired level of desalination. Advection is relatively a quick process of desalination contrary to diffusion. The desired desalination can be obtained in few days. Nevertheless, this process is limited with the size of pores of poultice and the substrate. The

efficient desalination by advection is obtained when the poultices contain many more pores of smaller size than the pores of substrate. Therefore this limitation for the desalination by advection is only for desalination of materials with big pores such as bricks, whereas advection is not efficient for the desalination of materials with relatively small pores such as concrete and mortars.

During the drying, the size of the pores in poultices varies in relation with the changes of a mass water content. The size of the pores diminishes in volume. Therefore it is difficult to adapt the size of pores for the highest efficiency of desalination. The other limitation for desalination using poultices may be the depth of building material in which the material should be desalinated. In the case of bricks, the depth where the desalination is efficient is about 20 mm from the surface. Moreover the use of poultices is difficult because the poultice has to be applied on the whole surface of a wall which is supposed to be desalinated. For the desalination by diffusion, it is necessary to change the poultices to keep the concentration gradient. Thus the salts can move into the poultice. [30]



Fig. 13 Application of poultice on the brickwork. [30]

5.2.2 Electrokinetics

The previous limitations are solved with the electrokinetic methods based on migration of ions (see Fig. 10). This method is currently the most used. Many electrokinetic experiments have been focused on the removal of chlorides from the concrete so far.

Electrokinetic methods have few advantages contrary to the classic application of poultices such as (i) the electrokinetic methods can be used for desalination of many materials regardless the size of the pores and their distribution, (ii) the electric field applied into the electrodes has better influence into the higher deep of the material, (iii) this technique can be used regardless the temperature and humid conditions, (iv) only few sets of electrodes can be used for the desalination contrary to the classic poultices where the whole wall has to be covered. [30]

5.2.3 The use of electrokinetics for the drying of bricks and brickwork

There have been many works so far which are aimed at the drying of the bricks by electro-osmosis. Firstly, the experiments were successfully tested in the laboratories where the decreases in the water contents were obtained. The pilot tests followed. At the pilot scale tests, it was possible to decrease the water contents in the walls and in the basement of a semi-detached house. The dewatering due to electro-osmosis is a long established method and is used mostly in Germany, Denmark, Austria. The technique was tested even in Czechoslovakia where the method called PU 10 based on electro-osmosis was developed.

5.2.4 The characteristic of the dried and desalinated materials

Generally, it is possible to say that the electrokinetics which uses an applied electric field is influenced by many factors such as the internal structure of a material (density), by the amount of the water in the pores and the ion concentration in an electrolyte. The drying and desalination under an applied field was successfully tested on different materials such as:

- wooden parts of the constructions;
- the ceramic materials with the filled structure–bricks of different types;
- the bricks together with a mortar;
- the sandstones;
- the limestones;
- the ceramic tiles and the different types of paints;
- concretes;

The examples for the use of electrokinetics in the field of civil engineering are shown in the following table:

Table 10 An overview where the electrokinetics is used in the civil engineering. [31]

Areas of electrokinetic application	The description of the treatment
Salt removal from concrete	The chloride ions are removed from the concrete under an applied DC field.
The re-alkalization of the concrete	The alkalinity which is important in concrete science may be established during electromigration due to the electrode processes.
The closure of the crack in the concrete	The special compounds of CaCO_3 and Mg(OH)_2 may be filled into the cracks by the electromigration.
Application of the different inhibitors against corrosion in the concrete	The degradation of concrete may be slowed down significantly due to the inhibitors such as amino compounds.
The cover as impregnation on the wooden structures	The special compounds of boron may cover and prevent degradation of the wooden constructions.
The salt removal from the brickwork	The concentration of the salts in the bricks may be decreased up to very low concentrations after the treatment.

Electrokinetics is used not only for the dewatering and the desalination of the materials but also in other fields. The examples for the use in the field of the environmental engineering are shown in the following table:

Table 11 An overview where the electrokinetics is used in the environmental engineering. [31]

Areas of electrokinetic application	The description of the treatment
Removal of the different heavy metals from the soil, sludge, fly ashes and sediments.	The electrokinetics offers the environmental friendly removal of heavy metals in connection with the pollutants from soils with the different grains.
Remediation of the groundwater	The effective removal of the pollutants from the water with the use of a passive membrane.
Removal of the organic contaminants from the soil	The organic element as phenol may be removed due to the electromigration.
The salt removal from the soil.	The salts which may cause the degradation of soils and lands may be removed due to the electromigration.
Removal of the radioactive elements from the concrete structures.	The power plant or concrete in general may be contaminated with some types of radio-nuclides that may be removed.

The experimental drying and desalination under an applied electric field in the presented dissertation was carried out on:

- the simple bricks of Danish format which were tap water saturated;
- the simple bricks of Danish format saturated with the sodium chloride solution;
- the sandstones from a warehouse;
- the pilot test was carried out on a brick wall of a stable;

The additional descriptions of the used materials are in the experimental part of the thesis.

5.3 Summary of the basic knowledge about the electrokinetics

It is possible to say that the drying and the desalination due to the influence of an electric field is efficient and quick. The advantages and disadvantages are described in more details in the following chapter:

5.3.1 The advantages and disadvantages of electrokinetics for the drying and the desalination

Among the basic advantages of electrokinetics belong:

- The method is non-destructive;
- It is possible to dry out only local areas which are more water saturated or salt contaminated and need to be treated. The drying of the specific places is not possible with other dehumidifiers;
- The technique does not have negative influences on people or any other organisms;
- The drying with electrokinetic technique is easy for the service;
- To dry out the area of interest together with the salt removal;

Among the basic disadvantages of electrokinetics belong:

- If a wall contains a lot of space (air room) between the brick and the mortar, the current flow cannot get through the whole material or a wall and stops in this place. Thus the water movement with the movement of the salts is limited;
- In the case of the desalination, it is necessary to put the samples to the laboratory for the analysis by chemists;
- The efficiency for the water removal is not as high as at the other dehumidifiers. There has been still much research left for upgrades of the setup units;
- The existing metallic parts in the wall have to be covered or the current interactions may occur;
- Higher energy costs;
- Too high density of current applied can create cracks in the material;

6 SPECIFICATION AND THE GOALS OF THE DISSERTATION

The dissertation deals with the extension of both theoretical and practical knowledge with the use of the electrokinetics in the field of civil engineering. The dissertation is focused on the sanitation of the building materials such as bricks, sandstones in relation to the moisture and the concentration of the most common salts. The issues of the moisture and the salts are wide enough and contain much knowledge from the fields as chemistry and physics.

6.1 The specification of the issue

The dampness and a high concentration of different types of salts in the basement is the problem especially at the older buildings where the precautions such as the waterproofing membranes against the water are completely missing or badly done.

The dissertation interconnects issues of the moisture and the salts. The theoretical part of dissertation (chapter 1-5), describes the problematic of the moisture, salts, electrokinetics and their relations to the building matters.

The important parts of the fundamental knowledge are the initial conditions which are different in the laboratory and on the building site. The amount of the water and the distribution of the salts in some laboratory experiments are supposed to be uniform contrary to the water contents and distribution of salts in the pilot tests. Thus it is difficult to evoke the similar conditions in the laboratories as the initial conditions on the building sites are. In the experimental part of the dissertation, the electrokinetic methods for the dewatering and desalination are tested with the materials such as bricks and sandstones.

The dissertation is focused on the experimental findings from the laboratory experiments and pilot tests. These findings are connected with the overall distribution of the moisture, pH and salt concentration in the tested materials. The pilot test is focused on the verification of the obtained results from the laboratory experiments. Many experimental works have been running so far and

many problems have been still unsolved. The results in the dissertation are unique and therefore it is difficult to verify them.

6.2 The goals of the dissertation

The main goals are in the complex experimental and the theoretical analysis of the dewatering and the desalination of the porous materials such as bricks, sandstones under the laboratory conditions and of the brickwork in the pilot test under an applied electric field. The final recommendations are based on these findings and analysis both from the laboratory and the pilot test.

6.2.1 The optimization of the closed laboratory setup for the dewatering of the tap water saturated bricks due to electro-osmosis using the different types of clay poultices

- To demonstrate electroosmotic flow and to find out which combination of the clay poultices is the most suitable and has the highest efficiency in relation to the dewatering of the bricks which were tap water saturated.
- To find out the overall changes of pH in the closed laboratory setup.

6.2.2 Desalination of the sandstones under the laboratory conditions using one type of clay poultice

- To desalinate the sandstones under an applied electric field to levels meeting the safety limits where no damaging risk is expected.
- To find out an overall charge, the efficiency of the desalination as the removal of mass and removal rate of chlorides, nitrates and sulphates.
- To verify whether electro-osmosis takes place in the closed laboratory setup and how much.
- To find out whether the placement of the sandstones (original outer surface) in relation to the electrodes has any significant influence on the efficiency of the desalination.
- To verify the suitability of the mixture used as the clay poultices in relation to pH changes.

6.2.3 The optimization of the closed laboratory setup for the desalination of the bricks saturated with sodium chloride solution using the different types of clay poultices

- To find out which combination of the clay poultices has the highest efficiency in decreases of the chloride concentration.
- To find out which combination has the highest decreases in the water contents inside the bricks at the end of the experiments.
- To find out the overall changes of pH in the closed laboratory setup.

6.2.4 Desalination of a brickwork in the pilot test

- To find out the efficiency of the desalination as the removal of mass and removal rate of chlorides, nitrates and sulphates when the specific constant current is applied.
- To use the obtained experience from the test for the recommendations how to desalinate the brickwork with the highest efficiency.

6.2.5 Desalination of the sandstone wall in the pilot scale test on the basis of laboratory results

- To give recommendations for the high efficiency of desalination of the sandstone wall, on the basis of results from the laboratory experiments.

7 THE METHODS USED IN THE DISSERTATION

In the dissertation, few basic methods were used for data analysis. The dissertation is based on the analogy method. This methodology helps for the exploring of the new findings. The analogy is based on already published scientific studies and on obtained results from the present experiments.

7.1 Theoretical methods

7.1.1 The study of literature and the consultation with experts

Theoretical knowledge was obtained mainly from the literature abroad, internet and from the cooperation with Denmark Technical University in Lyngby (DTU), Denmark. The theoretical knowledge and findings were discussed with the experts for the dewatering and the desalination at DTU in Lyngby, Denmark.

7.2 Experimental methods

7.2.1 Laboratory methods

Every laboratory experiment was conducted at Denmark Technical University in Lyngby in the cooperation with the department of the materials. With the use of abstraction method, the real constructions were replaced with the simplified models such as simple bricks and sandstones. In these models, the simplified conditions were evoke mainly because of easier implementation for the dewatering and the desalination.

The following materials were used as simplified models:

- the yellow bricks of Danish format $22.8 \cdot 10.8 \cdot 5.4$ cm,
- Obernkirchen sandstones with the different levels of the salt concentrations and porosity (16–21 %) and the dimensions approximately $50 \cdot 10 \cdot 7$ cm,

In the laboratory experiments the following data were collected and calculated:

- The water contents at the beginning and at the end of the experiments – the gravimetric method,
- The changes of pH at the beginning and at the end of the experiments – pH meter,
- The changes of the voltage during the duration of the experiments,
- The initial and the final concentration of chlorides – titration,
- The initial and the final concentration of the salt anions (chlorides, nitrates, sulphates) – the ion chromatography,

7.2.2 Methods used in the pilot test

The dewatering and desalination of a real wall when an electric field was applied was also conducted. Firstly, the initial examination of the water contents and concentrations of salts from the samples taken from the wall of interest was done. On the basis of the evaluation of the initial water contents, concentration of salts and the historic facts, it was found out which salts damaged the wall and the plaster mostly. After the application of the clay poultices on the part of the wall, which was the aim of the desalination treatment, electric field was applied into these clay poultices.

In the pilot experiment the following data were collected and calculated:

- The initial and the final water contents from the samples – the gravimetric method,
- The voltage during the duration of the pilot test,
- The initial and the final concentration of salt anions (chlorides, nitrates, sulphates) – the ion chromatography,

7.2.3 The used equipments

- Digital weight Sartorius CP3202S;
- Membran – Vakuumpumpe ME;
- PHM220 Lab pH meter;
- 716 DMS Titrino 727 Ti Stand;
- The mechanical mortar and the oven;

- Ion chromatography device;
- DC power supply Hewlett Packard E3612A;

7.3 The comparative method

The comparative method was used both for the experiments in the laboratory and in the pilot test. The results from the laboratory experiments were compared with each other. The results from the present pilot test were compared with the results from the previous pilot tests to get the final conclusions.

8 EXPERIMENTAL DRYING AND DESALINATION UNDER AN APPLIED ELECTRIC FIELD

8.1 EXPERIMENT 1 – To find out the combination of the clay poultices which is the most efficient for the dewatering of the tap water saturated bricks due to electro-osmosis under an applied electric field

8.1.1 Introduction

The electro-osmosis may be influenced significantly by the composition of the clay poultices together with the changes of pH during the electroosmotic flow. Therefore the following findings in the laboratory experiments might contribute to the improvement of the dewatering under an applied electric field. The experiment tightly follows the previous study [32].

8.1.2 The goals of the experiment 1

The experiment 1 focuses on:

- (1) to demonstrate the electroosmotic flow in the closed laboratory setup with the combination of two types of the clay poultices,
- (2) to find out which combination of the clay poultices is the most suitable and has the highest efficiency in relation to the dewatering of the bricks which were tap water saturated,
- (3) to find out which combination of the clay poultices creates the least amount of OH^- ions inside the bricks and inside the clay poultices,

8.1.3 The experimental section

The bricks used for the laboratory experiments were taken from Wienerberger's brickfield. Danish yellow bricks of dimensions $22.8 \cdot 10.8 \cdot 5.4$ cm were used in every laboratory experiment (see Fig. 14). The porosity of these yellow bricks was about 28.0 % (given from a factory). Every experiment was conducted with 2 halves of the brick. In the laboratory experiments, two types of the clay poultices were used (see Fig. 14).

- a mixture of (calcite, distilled water or tap water and kaolin) – the tap water contains a lot of free ions and therefore these free ions could influence the conductivity of the clay poultice. The conductivity of the tap water was measured between $0.7\text{--}0.8 \text{ mS}\cdot\text{cm}^{-1}$;
- the brick clay – it contains approximately 17.0–18.0 % carbonates (data from Wienerberger’s brickfield);



Fig. 14 The used yellow bricks, the clay poultices – the mixture (white), the brick clay (brown); [33]

8.1.4 Materials for experiments

- the yellow Danish bricks;
- the rubber stoppers, the rubber tape band;
- an adhesive tape;
- the plastic lids, vials, cylinders and a plastic film;
- the electrode platinum covered from Permascand;

8.1.5 Analytical

In the present experiment 1, the water soluble fraction in the distilled water is relevant for the measurements. Before analysis, the halves of bricks were segmented to 4 pieces and the clay poultices were segmented to 4 slices on the both sides (see Fig. 16). Inside these slices the water contents and pH were measured. The water content was found by the weigh and dry method (drying for 24 hours at $105 \text{ }^\circ\text{C}$) and calculated as $(\text{water/dry mass}) \cdot 100 \%$. The dried samples of the clay poultices were powdered in a mortar by hand and the bricks in a mechanical mortar. The fine powder was suspended – 10 g of powder in 25

ml of the distilled water in the plastic vials, which were placed on an agitating table for 24 hours. After this pH (PHM 220 Lab pH Meter) was measured with electrodes directly in the suspensions.

8.1.6 The experimental setup

At the beginning of the experiments, the whole brick was put into the oven to dry up over the night. The next day, the whole dried brick was segmented with a hammer and a chisel by hand to 2 similar halves. These dried halves were weighed and then submerged into the tap water to evoke similar conditions, which are on the building site because the water which can get inside the walls is not clear like distilled water which does not contain any minerals. After 2 hours of submersion the two halves were weighed again. Every experiment was conducted with 2 such water saturated halves of the brick (see Fig. 17).

Plastic cylinders; 5 cm long and with an internal diameter of 10 cm were used as the electrode compartment. The cylinders had open bottoms which were closed with the plastic lids. Each cylinder had 2 holes (diameter 1 cm). These holes were closed with the rubber stoppers. On the edge of the cylinders facing the brick the rubber tape band was placed for better contact with the brick. So prepared cylinders were filled with the mixture or brick clay up to the edges of the rubber tape band. The halves of the bricks were placed between the cylinders.

Then the grabs were used to press the setup together. One stopper was put out of the cylinder on each side to the mixture or the brick clay could go out from the cylinder during tightening the grab. After this procedure the electrodes were placed with the stoppers in the outer holes. The electrodes reached 7 cm into the electrode compartment. Every half of brick was wrapped with a plastic film to minimize the evaporation from the setup during the duration of the experiment. Finally, a constant voltage was applied to the electrodes by a DC power supply (Hewlett Packard E3612A). The laboratory setup is shown in Fig. 15.

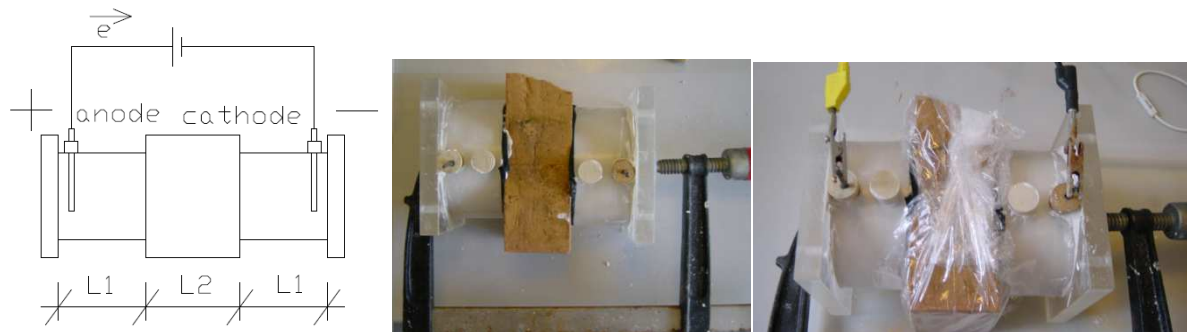

Fig. 15 The closed laboratory setup of the electrodes connected to the power supply.
 L1 – the clay poultice; L2 – a half of the brick; [33]

8.1.7 The experimental series

Overall eleven electrokinetic experiments were conducted. Every experiment was done with two halves of the brick. The experiments are outlined in the Table 12 by the experimental conditions. The experiments had different duration and an applied constant voltage was between (30.1–30.4 V). The changes in the current were monitored within the day from 9 a.m. till 5 p.m. an every hour during the duration of the experiments.

Table 12 The experimental initial conditions for the experiments – type of the poultice, the duration, the initial current, the initial constant voltage, the weight of dried halves of the bricks, the initial water contents of halves of bricks. DW – distilled water; TW – the tap water; BR.1 – half 1; BR.2 – half 2; KAOL. – kaolin; [33]

Exp.	Poultice ANODE	Poultice CATHODE	Duration [h]	Current [mA]	Volt. [V]	Weight of dried bricks [g]	Water contents [%]
1	(CaCO ₃ + DW + KAOL.)	(CaCO ₃ + DW + KAOL.)	BR.1 = 72 BR.2 = 49	12.0; 9.0	30.2; 30.1	1381.5; 853.9	13.7; 13.7
2	(CaCO ₃ + TW + KAOL.)	(CaCO ₃ + TW + KAOL.)	BR.1 = 116 BR.2 = 116	19.0; 18.0	30.4; 30.2	1216.8; 1001.1	14.7; 14.1
3	BRICK CLAY	BRICK CLAY	BR.1 = 142 BR.2 = 142	21.0; 23.0	30.4; 30.4	1113.2; 10906	15.4; 13.8
4	(CaCO ₃ + DW + KAOL.)	BRICK CLAY	BR.1 = 142 BR.2 = 142	23.0; 23.0	30.2; 30.2	1269.5; 1266.3	16.1; 15.9
5	BRICK CLAY	(CaCO ₃ + DW + KAOL.)	BR.1 = 142 BR.2 = 142	23.0; 23.0	30.3; 30.3	1331.0; 1232.3	16.0; 16.3
6	(CaCO ₃ + DW + KAOL.)	(CaCO ₃ + DW + KAOL.)	BR.1 = 162 BR.2 = 162	14.0; 14.0	30.3; 30.3	1221.9; 978.1	15.4; 14.9
7	(CaCO ₃ + DW + KAOL.)	(CaCO ₃ + DW + KAOL.)	BR.1 = 242 BR.2 = 242	18.0; 15.0	30.3; 30.4	11307; 1068.3	16.6; 14.9
8	(CaCO ₃ + TW + KAOL.)	(CaCO ₃ + TW + KAOL.)	BR.1 = 260 BR.2 = 260	23.0; 22.0	30.3; 30.3	1110.1; 1070.1	16.2; 17.0
9	BRICK CLAY	BRICK CLAY	BR.1 = 204 BR.2 = 204	20.0; 20.0	30.3; 30.3	1221.9; 978.1	13.9; 14.7
10	(CaCO ₃ + DW + KAOL.)	BRICK CLAY	BR.1 = 214 BR.2 = 214	21.0; 22.0	30.3; 30.3	1118.4; 1095.1	16.1; 17.2
11	BRICK CLAY	(CaCO ₃ + DW + KAOL.)	BR.1 = 233 BR.2 = 233	25.0; 15.0	30.4; 30.4	1182.0; 1000.4	17.1; 17.0

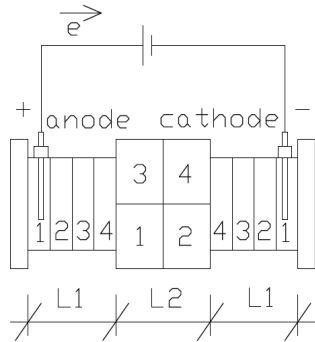

Fig. 16 The segmented parts, where the water contents and pH were measured.
L1 – the clay poultice, L2 – half of the brick;

8.1.8 Results and discussion

In the experiments, the changes in the water contents and pH were measured. Because there were many samples in the closed laboratory setup the average values were calculated together with their standard deviations. The average percentage decreases or increases of these values were related to the average values.

The reference bricks

It must be taken into account that the differences in the initial water contents inside the halves of the bricks were measured even when the bricks were taken from the same batch. In the experiments, the initial water contents of the bricks were measured between the numerical values (13.7–17.2 %; see Table 12). Table 13 shows the changes in the water contents in the small additional experiment in which two halves of the brick were submerged into the tap water for few days. The deviations in the water contents were measured. In general, the longer submersion of the two halves was, the less deviation in the water content between the two halves was.

When the initial values of pH were measured the deviations were also seen. The reference pH for the bricks was calculated from five brick samples which were taken from five various yellow Danish bricks. The average numerical value and the standard deviation of pH was then calculated (10.5 ± 0.03). This numerical value of pH was taken as reference pH for the bricks in the experiments.



Fig. 17 The halves of the brick submerged in the tap water for two hours.

Table 13 The changes in the water contents inside the two halves of the brick - the initial weight of the dried halves, the water contents during the submersion and the differences in the water contents between the two halves in relation to the time; [33]

Date	Time	Half 1 during [g]	Water content 1 [%]	Half 2 during [g]	Water content 2 [%]	Difference in the water content [%]
8.12.	10:00	1182.25	< Initial weight >	1000.69		
	11:00	1388.52	17.45	1172.41	17.16	0.29
	12:00	1389.25	17.51	1172.57	17.18	0.33
	13:00	1389.90	17.56	1174.15	17.33	0.23
	15:00	1390.83	17.64	1174.86	17.40	0.24
9.12.	9:00	1392.93	17.82	1176.65	17.58	0.24
11.12.	14:30	1398.85	18.32	1182.05	18.12	0.20
12.12.	10:00	1400.54	18.46	1183.79	18.30	0.17
	14:00	1400.66	18.47	1183.98	18.32	0.16
13.12.	9:00	1401.78	18.57	1185.01	18.42	0.15
	11:00	1182.25	18.58	1185.25	18.44	0.14
	13:00	1388.52	18.59	1185.35	18.45	0.14
14.12.	9:00	1389.25	18.73	1186.70	18.59	0.14
	13:00	1389.90	18.83	1187.76	18.69	0.13

Electro-osmosis inside the bricks and the clay poultices

In every experiment the water transport was clearly seen since the clay poultices at the anode side had lower water contents than the poultices at the cathode side in every experiment (see Table 14) and moreover water (about 10-15 ml) was also seen under the clay poultices on the underlay at the cathode side but never under the anode side.

The pattern of the water contents inside the halves of the bricks were unclear in the experiments 1–6. The decreases in the water contents inside the bricks were expected higher inside the anode halves of bricks since the water movement was towards the cathode. The overall changes in the water contents in the experiments 1–6 are shown in Fig. 18 and Fig. 19. Possibly, the main reason for the unclear patterns and non-successful decreases in the water contents inside the bricks in the experiments 1–6 was in the short duration. Therefore the experiments were repeated with the longer duration.

After the repetition of the experiments with the longer duration, the average decreases of the water contents inside the bricks were only in the repeated experiments 9, 10 and 11. The combinations where the mixture as the clay poultice was used on the both sides showed the increases or unexpected pattern even with the longer duration of the experiments. The overall changes in the water contents in the bricks and in the clay poultices are shown in the Fig. 20, Fig. 21 and in Table 14.

Electro-osmosis inside the bricks – the experiments with the shorter duration

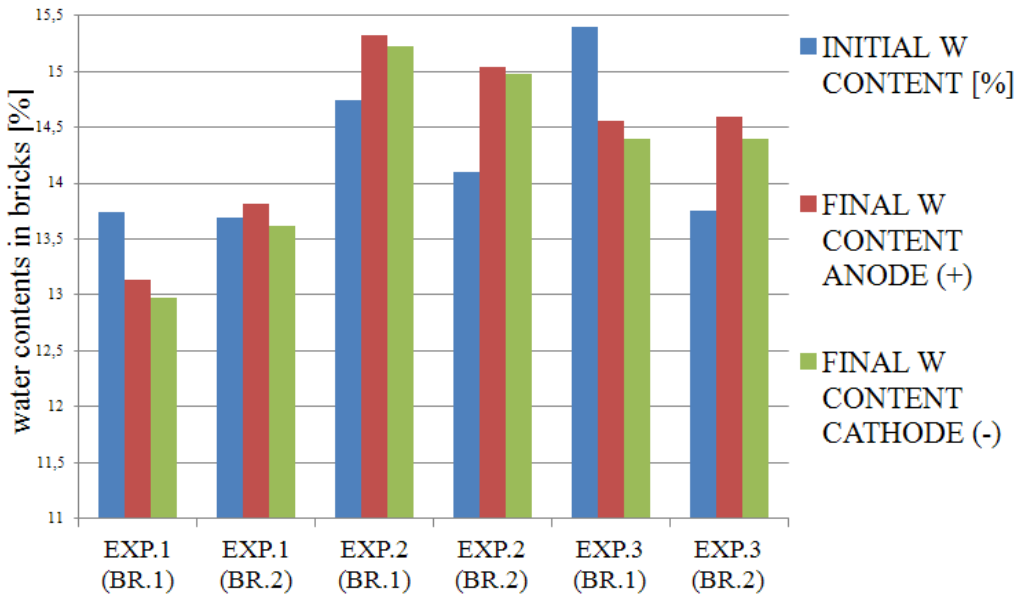

Fig. 18 The changes in the water contents inside the halves of the bricks at the of experiments 1, 2 and 3. BR.1 – half 1; BR.2 – half 2; [33]

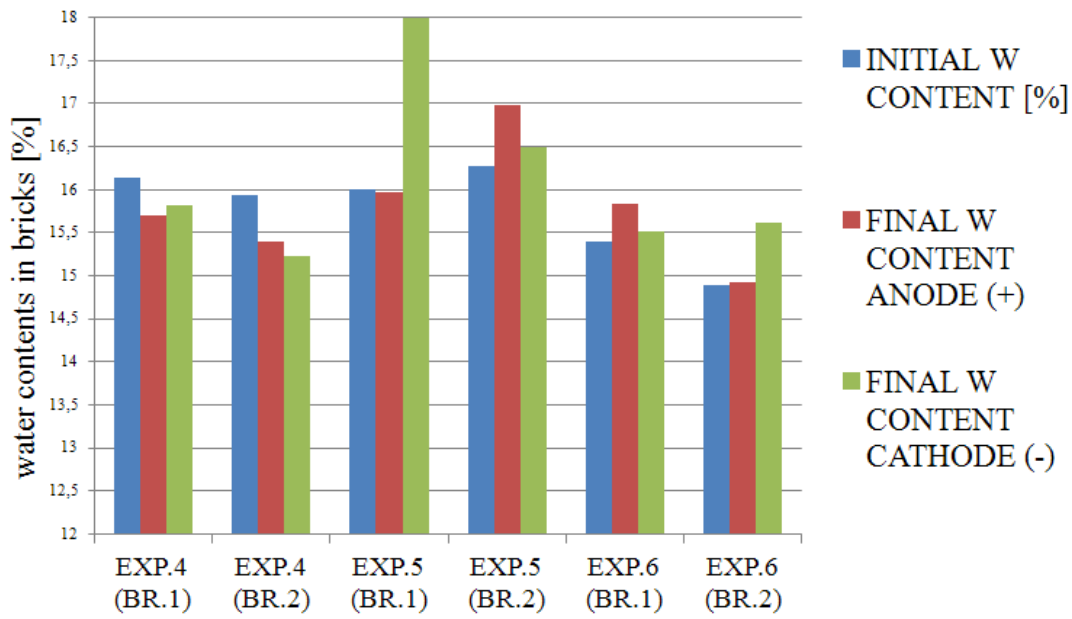

Fig. 19 The changes in the water contents inside the halves of the bricks at the end of experiments 4, 5 and 6. BR.1 – half 1; BR.2 – half; [33]

Electro-osmosis inside the bricks – experiments with longer duration

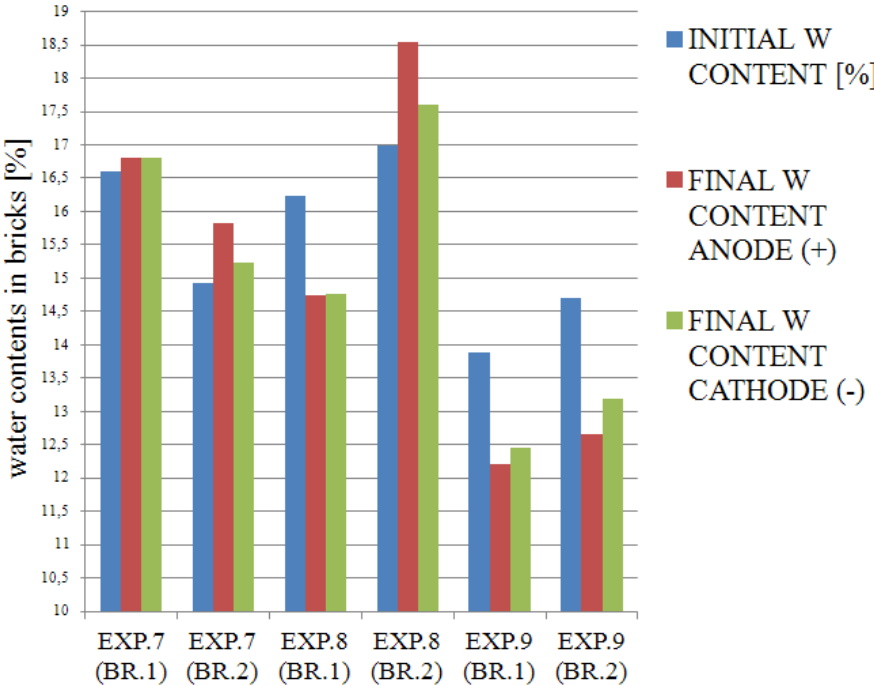

Fig. 20 The changes in the water contents inside the halves of the bricks at the end of experiments 7, 8 and 9. BR.1 – half 1; BR.2 – half 2; [33]

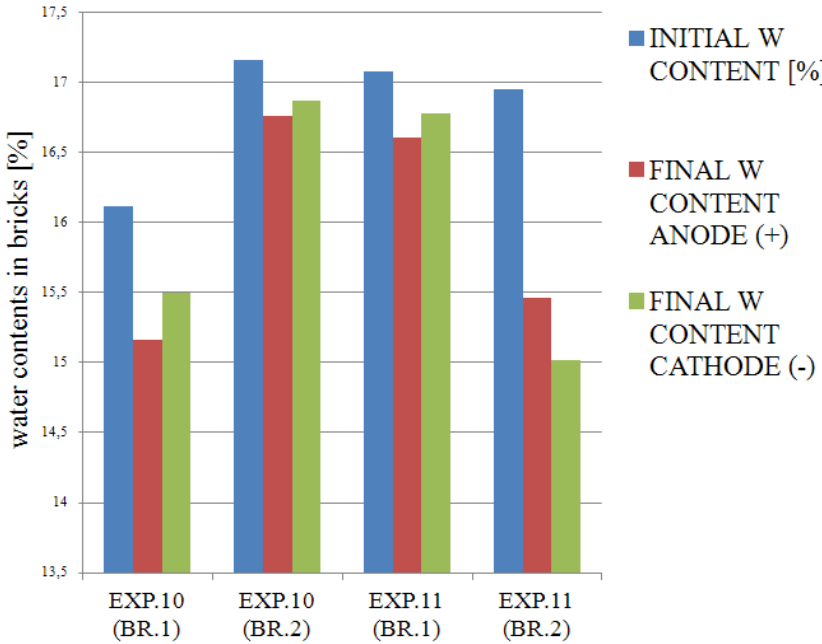

Fig. 21 The changes in the water contents inside the halves of the bricks at the end of experiments 10, 11. BR.1 – half 1; BR.2 – half 2; [33]

Table 14 The type of the used poultices, the initial water contents of the poultices, the final water contents inside the anode and cathode poultices at the end of the experiments. DW – the distilled water; TW – the tap water; KAOL. – kaolin; [33]

Poultice type	Initial water contents [%]	Poultice ANODE [%]	Poultice CATHODE [%]
Brick clay	21.0-24.9	14.6-19.0	17.1-21.3
mixture (CaCO ₃ + KAOL. + DW)	42.9-45.0	32.6-36.7	35.2-40.0
mixture (CaCO ₃ + KAOL. + TW)	42.3-46.3	33.1-35.7	35.9-39.0

The changes in pH inside the bricks

Before the experiment started it was expected that the pH in the bricks would be lower close to the anode poultice because of the electrode reaction from which H⁺ ions are created contrary to the cathode where the electrode reaction creates OH⁻ ions. In the experiments 1–5 with the shorter duration that expected pattern was not clear (see Fig. 22). In the experiments 6–11 where the duration was longer the expected pattern was obtained in more cases (see Fig. 23 and Fig. 24).

pH changes in the anode clay poultice (see Table 15)

The highest average percentage decreases in pH were measured in the experiment 10. The least average percentage increases in pH at the anode side of the clay poultices were measured in the experiment 3 only about (1.9–1.6 %) contrary to the initial value of pH (8.1) and see Table 16.

pH changes in the cathode clay poultice (see Table 15)

The lowest average percentage increases in pH in the cathode clay poultice at the end of the experiments were measured in the experiment 3 (5.3–1.9 %) and in the experiment 9 (7.4–7.8 %) contrary to the initial value of pH (8.1) and see Table 16. Generally, increases of pH were measured higher at the cathode side of the clay poultices than at the anode side of the clay poultices.

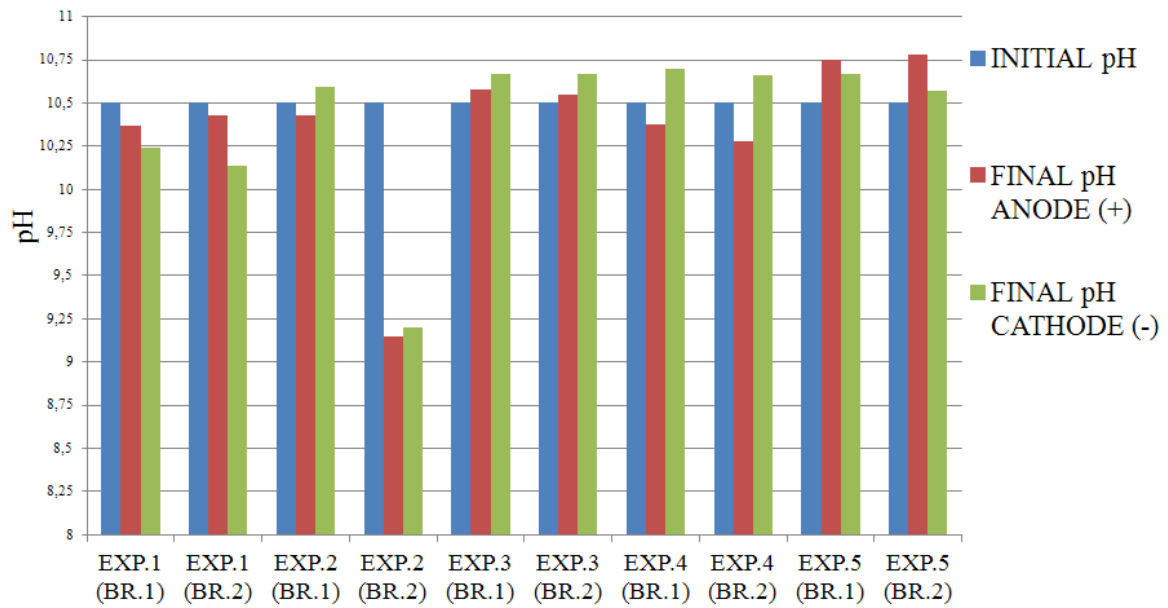

Fig. 22 The changes in pH in the bricks related to the initial pH value (10.5 ± 0.03) at the end of experiments 1–5. BR.1 - half 1; BR.2 - half 2; [34]

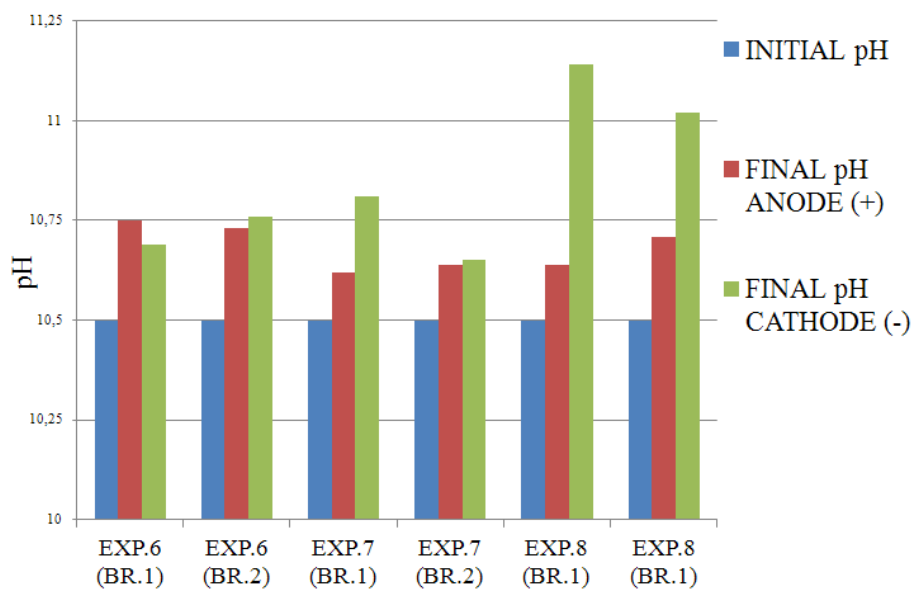

Fig. 23 The changes in pH in the bricks related to the initial pH value (10.5 ± 0.03) at the end of experiments 6–8. BR.1 - half 1; BR.2 - half 2; [34]

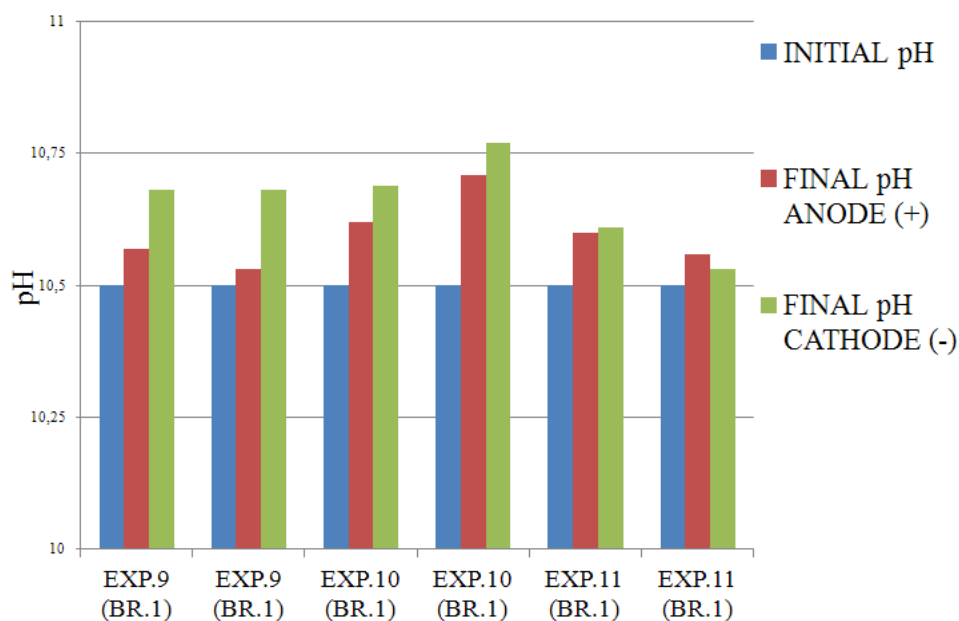

Fig. 24 The changes in pH in the bricks related to the initial pH value (10.5 ± 0.03) at the end of experiments 9–11. BR.1 - half 1; BR.2 - half 2; [34]

Table 15 The initial pH inside the clay poultices. The final pH inside the anode and cathode clay poultices at the end of the experiments. DW – the distilled water; TW – the tap water; KAOL. – kaolin; [34]

Poultice type	Initial pH	pH in the anode poultice	pH in the cathode poultice
Brick clay	8.0-8.1	8.1-8.5	8.8-10.5
mixture (CaCO_3 + KAOL. + DW)	8.6-8.8	8.1-8.3	9.0-11.0
mixture (CaCO_3 + KAOL. + TW)	7.3-7.7	8.2-9.0	10.2-10.6

Table 16 The percentage changes in pH in the clay poultices on the anode and cathode sides related to the initial pH of every clay poultice at the end of the experiments. BR.1 - half 1; BR.2 - half 2; DEC. – the average percentage decrease; INC. – the average percentage increase; [34]

		ANODE POULTICE				CATHODE POULTICE			
		BR.1	BR.2			BR.1	BR.2		
exp.1	DEC.	0.8	0.8	DEC.	INC.	7.8	3.8	INC.	
exp.2	INC.	12.4	4.3	INC.	INC.	40.1	45.5	INC.	
exp.3	INC.	1.9	1.6	INC.	INC.	5.3	1.9	INC.	
exp.4	DEC.	4.6	6.6	DEC.	INC.	14.6	14.6	INC.	
exp.5	INC.	4.0	3.9	INC.	INC.	24.0	23.4	INC.	
exp.6	DEC.	3.9	5.5	DEC.	INC.	15.4	18.5	INC.	
exp.7	INC.	3.8	4.7	INC.	INC.	24.6	20.9	INC.	
exp.8	INC.	23.8	13.6	INC.	INC.	52.6	40.9	INC.	
exp.9	DEC.	3.3	2.3	DEC.	INC.	7.4	7.8	INC.	
exp.10	DEC.	7.7	7.5	DEC.	INC.	12.2	11.9	INC.	
exp.11	INC.	4.2	3.5	INC.	INC.	26.9	16.5	INC.	

8.1.9 The conclusion

The experiments were conducted with one type of yellow bricks which were tap water saturated and with two types of poultices.

- (1) The demonstration of the electroosmotic flow was found out because the decreases of the water contents were higher at the anode clay poultice than at the cathode clay poultice in the every case (see Table 14).

Generally, the water contents in the bricks decreased in comparison with the initial water contents only at the combination, where the brick clay as the poultice was used at least on the one side of the closed laboratory setup within 10 days.

- (2) The combination of the poultices where the brick clay was used on the both sides of the closed laboratory setup showed that the brick clay was dried the least on the anode side from all experiments (see Table 14). In addition, the same combination (experiments 3, 9) showed even the highest decreases in the water contents inside the bricks from all experiments from the initial water contents (15.4–14.7 %) to the final water contents (14.5 and 12.7 %; see Fig. 18 and Fig. 20).

This detection might have been useful especially for the pilot test since the use of this combination could have led to less changes of dried brick clay and it could have saved both money for the clay and the time for the change.

- (3) The combination where the brick clay was used on the both sides showed only the slight average increases in pH in relation to the initial values of pH inside the bricks from the initial values (10.5 ± 0.03) to values (10.6–10.7; see Fig. 22 and Fig. 24).
- The lowest increase in pH was also measured at the cathode clay poultice from the initial pH of the brick clay (8.1) to values (8.5–8.2) in the experiments 3 and 9 (see Table 15 and Table 16).

Low increase in pH at the cathode side is expected to be useful because it is clear that the amount of created OH^- ions is not so high and the low amount of OH^- ions may have better influence on the efficiency of electro-osmosis and desalination. In every experiment, the clay poultices buffered to decrease pH below 7 which would mean unwanted acidification because the clay poultice contained a high amount of carbonates.

The consistency of the mixture used as poultice seems to be inconvenient for the electroosmotic dewatering of bricks because it contains a high water amount and that was probably the main reason for the unsuccessful dewatering under the laboratory conditions. Also the bad contact during the experiments as a consequence of too much dry clay poultice at the anode side might have influenced the efficiency of electro-osmosis negatively. The bad contact was especially in the experiments where the mixture was used as the clay poultice. The pressure/suction effect between the bricks and the clay poultices might have been another reason for the unsuccessful dewatering.

In the future, that problem might be solved with the use of the meshed electrodes on the anode side because that side was dried up more at the end of the experiments. Also the investigation of a new mixture especially its consistency might be a good solution how to improve the electroosmotic flow.

8.2 EXPERIMENT 2 – Desalination of sandstones using clay poultices with an applied electric field

8.2.1 Introduction

The present experiment 2 was conducted with the sandstones which were removed during the renovation from a historic warehouse. The sandstones contain chlorides, nitrates, sulphates and the work was focused on decreasing in the concentrations of all those, as they can cause irreversible damage. The technique of the poultices was used. The present experiment follows the previous studies [35] [36].

8.2.2 The goals of the experiment 2

The experiment 2 focuses on:

- (1) to see whether it is possible to desalinate the sandstones to levels meeting safety limits where no damaging risk is expected,
- (2) to verify whether electro-osmosis (the water movement under an applied DC field) takes place,
- (3) to find out whether the placement of the sandstones (original outer surface) in relation to the electrodes has any influence on the efficiency of desalination,
- (4) to verify the suitability of a mixture used as a poultice in relation to the pH changes and water contents,
- (5) to find out the removal rate, removed mass for chlorides, nitrates and sulphates when the constant current is applied,

8.2.3 The experimental section

The sandstones for the experiments

Two sandstones used in the laboratory experiments were taken from the main entrance gate of the historic warehouse Eigtued Parkhus on Strandgade in Copenhagen, Denmark. They were cut out from a larger stone which was damaged by the salts. The sandstones were about 0.5 m long and 5 to 7 cm

thick. They had gray colour (see Fig. 25 and Fig. 26). A relatively smooth surface of the sandstones had been the original outer surface and the rough surface had been facing towards the wall. Lighter and darker areas were clearly seen (see Fig. 25) on the smooth surfaces of the stone 1. There were not found any darker areas on the surface of the stone 2 (see Fig. 26). The stones contained unknown amount of the salt concentration but it was expected that these white and dark areas contained high concentration of salts. The two experimental stones (1 and 2) were weighed and further segmented with a hammer and a chisel by the hand to 4 segments each (Fig. 25 and Fig. 26). For the segmentation of the stones sawing was not used because this would add extra water to the stone segments which could cause unwanted redistribution of the salts. After the segmentation, the desalination experiments were conducted with these stone segments.

In the laboratory experiments, one type of the poultice was used:

- a mixture of (calcite, distilled water and kaolin) and (see Fig. 14);

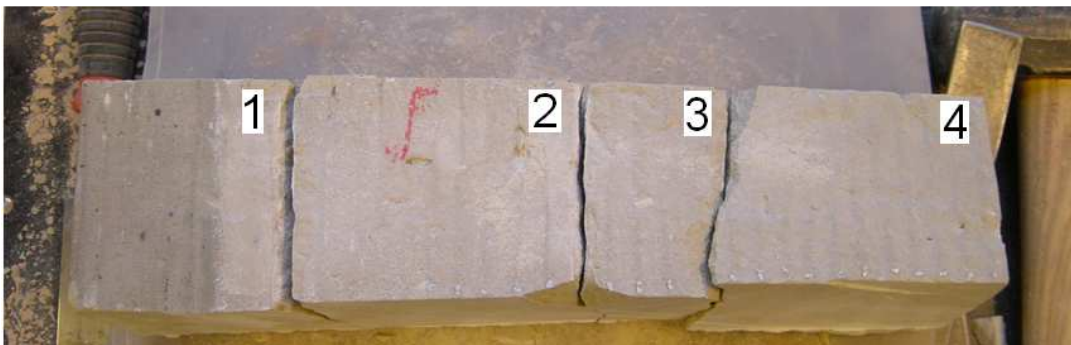

Fig. 25 Four segments of the stone 1. The stone segment 3 was used as the reference.

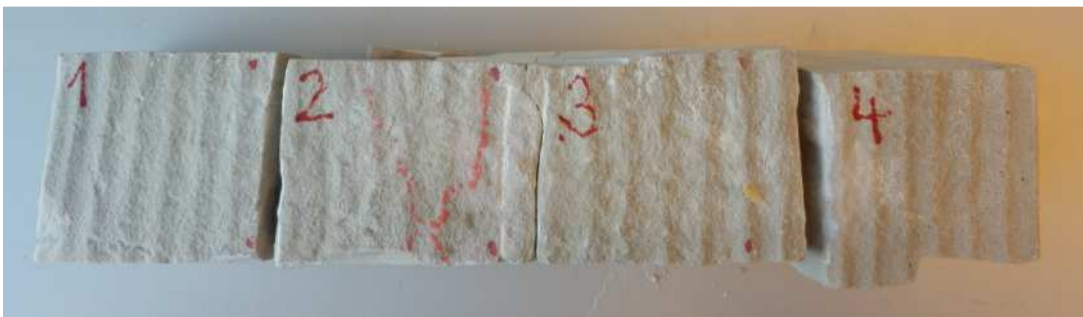

Fig. 26 Four segments of the stone 2. The stone segment 3 was used as the reference.

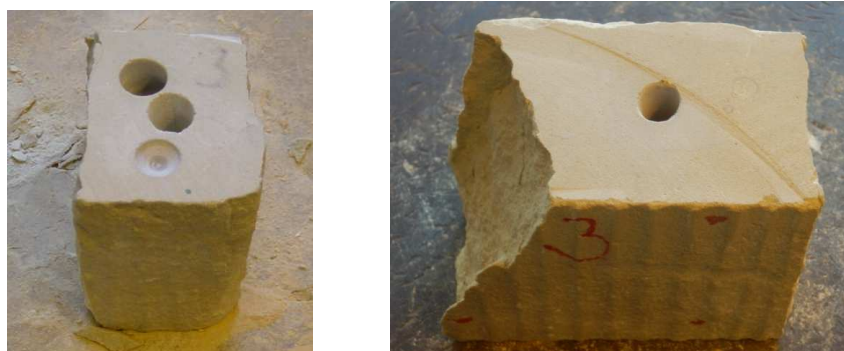

Fig. 27 The reference stone segment 3 (on the left) from the stone 1 was used as reference for the experiments 1, 2 and 3. The reference stone segment 3 (on the right) from the stone 2 was used as reference for the experiments 4, 5 and 6.

8.2.4 Materials for experiments

- the sandstones (Obernkirchen Sandstones);
- the rubber stoppers, the rubber tape bands;
- an adhesive tape;
- the plastic lids, vials, cylinders, the plastic film for wrapping;
- the electrode platinum covered from Permascand;

8.2.5 The analytical

Prior to the chemical analysis of Cl^- , NO_3^- , SO_4^{2-} the stone segments were segmented to 4 pieces and the clay poultices were segmented to 4 slices on the both sides (see Fig. 28). The reference stone segments were segmented the same way (see Fig. 29). Inside these segments and slices the water contents were measured. The water contents were found by the weigh and dry method (drying for 24 hours at 105°C) and calculated as $(\text{water/dry mass}) \cdot 100\%$.

Then the extractions were made with 10 g of dried powdered sandstone (powdered in a mechanical mortar) or 10 g of dried clay (powdered by hand) and 25 ml distilled water. The suspension was placed on an agitating table for 24 hours. After this time, pH was measured with the electrodes directly in the suspension by a PHM 220 Lab pH Meter. After the filtration through $0.45\ \mu\text{m}$ under vacuum, the concentration of chlorides, nitrates and sulphates was measured in the segmented parts of the laboratory setup and reference segments with the ion chromatography (see Fig. 28 and Fig. 29).

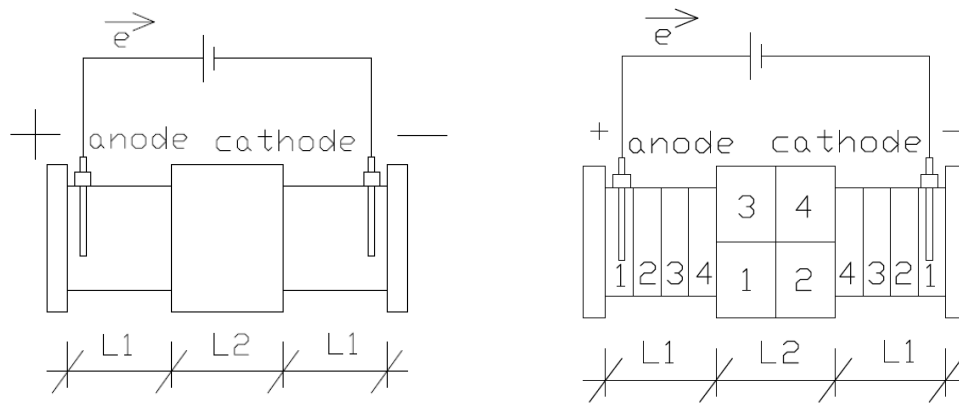

Fig. 28 The laboratory closed setup (left) used in the experiments, the segmented parts of each laboratory compartment where the water contents, pH and the concentration of the salts were measured (right). L1 – the clay poultice, L2 – sandstone;

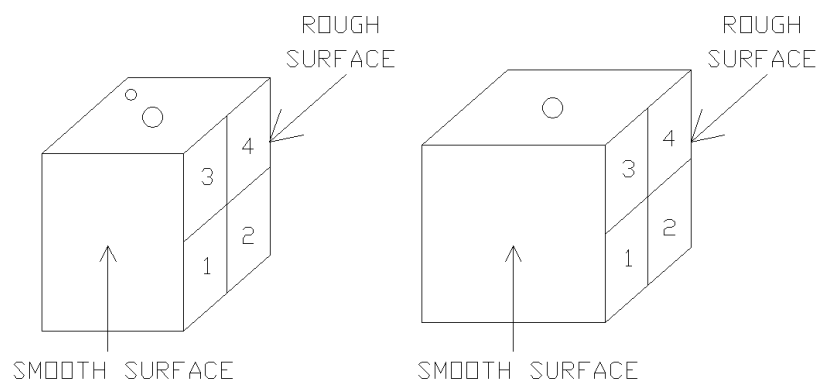

Fig. 29 The reference stone segments from the stone 1 and 2. The reference stone segment 3 (on the left) was used for the experiments 1, 2 and 3. The reference stone segment 3 (on the right) was used for the experiments 4, 5 and 6. The numbers show the segmented parts of the reference stones where the water contents, pH and the concentration of salts were measured.

8.2.6 The experimental setup

The laboratory setup for the electrokinetic desalination experiments is shown in Fig. 30. After the segmentation (see Fig. 25 and Fig. 26) a known quantity of tap water was sprayed on the stone segments to supply the moisture to the pores except the reference stone segments. The tap water for spraying had the conductivity between $0.7\text{--}0.8 \text{ mS}\cdot\text{cm}^{-1}$. Submersion the stone segments in the water was not an option since the salts could have been washed out.

Plastic cylinders; 5 cm long and with an internal diameter of 5 cm were used as the electrode compartments. The cylinders had open bottoms which were closed with the plastic lids. Each cylinder had 2 holes (diameter 1 cm). These

holes were closed with the rubber stoppers. On the edge of the cylinders facing the stone segment the rubber tape band was placed for better contact with the segmented stones. So prepared plastic cylinders were filled with the mixture (see Fig. 14). The stone segments were placed between the two filled cylinders. The grabs were used to press the setup together. One stopper was put out of the cylinder on each side to mixture could go out from the cylinders during tightening the grab. It was a sign that no room was in the cylinders. The placement of the smooth and the rough sides of the stone segments in relation to the electrodes (see Fig. 31) was taken into account. Electrodes were placed in the stoppers in the outer holes. The electrodes reached 3 cm into the electrode compartment and were platinum covered with a diameter of 3 mm. The stone segments were wrapped in the plastic film to hinder the evaporation during the desalination experiments (see Fig. 30). A constant current of 2 mA was applied to the electrodes by a DC power supply (Hewlett Packard E3612A).

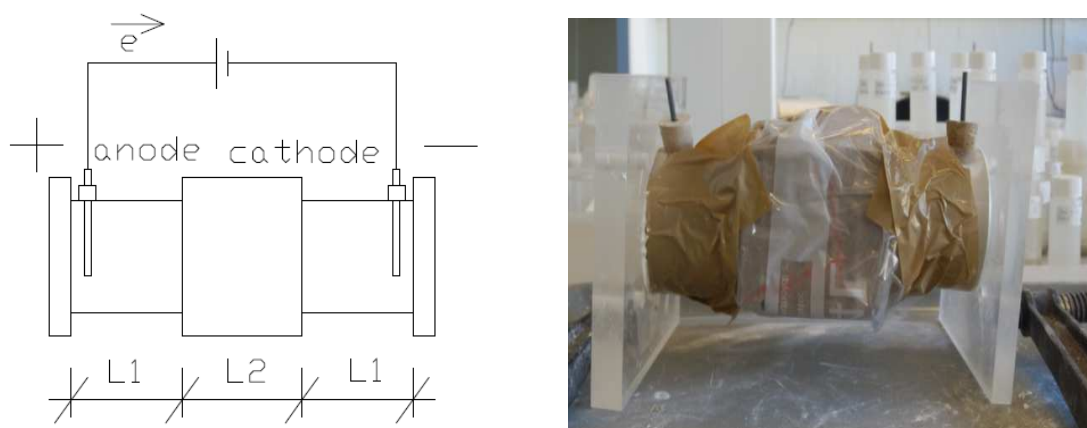

Fig. 30 Laboratory closed se up of the electrodes connected to the power supply.
L1 – the clay poultice, L2 – the segmented stone;

8.2.7 The experimental series

Six electrokinetic desalination experiments were conducted. The experiments are outlined in Table 17 by the experimental conditions and by the placement of the stone segments in relation to the electrodes (see Fig. 31). All experiments were conducted with the constant current of 2 mA and the voltage had been followed. A good contact during the lasting of the experiments was not maintained (read The results and discussion).

Table 17 The experimental conditions for the desalination experiments – duration, the initial current, the initial voltage, weight of the dried stone segments, the initial water contents, the placement of the stone segments (see Fig. 31);

Exp.	Duration [h]	Current [mA]	Initial Voltage [V]	Weighted dried sandstone [g]	Initial water content [%]	Placement of stone segments (Fig. 31)
1	120	2	14.8	936.6	1.9	(a)
2			9.7	1022.4	2.0	(a)
3			14.8	916.4	1.5	(b)
4	240	2	13.9	693.9	1.3	(a)
5			12.9	881.4	1.6	(b)
6	264		12.5	746.8	1.7	(b)

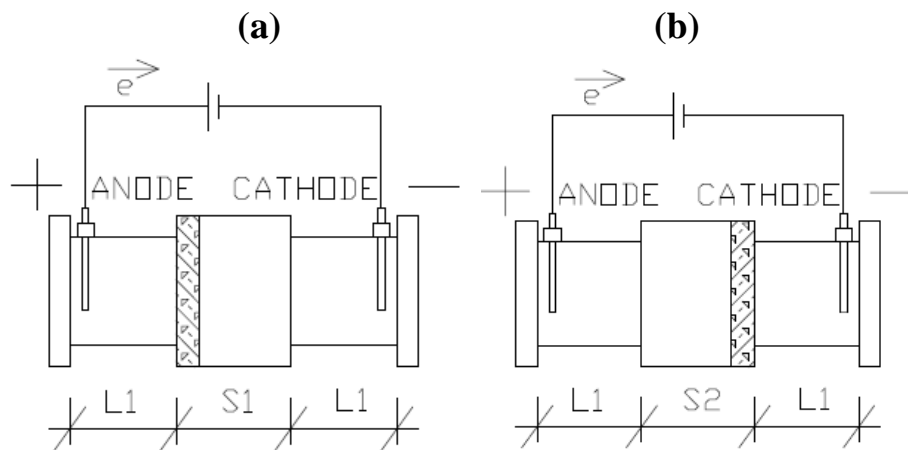

Fig. 31 The placement of the stone segments in relation to the electrodes.

- a) Original outer surface towards the cathode;
 b) Original outer surface towards the anode; L1 - the clay poultice; S1, S2 - the stone segment;

The reference stone segments

Because the stones are from a non-homogeneous natural material, the differences were expected even though the stones were taken from the same area. From the evaluation of the chlorides, nitrates and sulphates under an applied electric field it was necessary to know the variation of the salt concentrations in the two reference stone segments. No water was added or DC field applied into the reference stone segments.

The water contents, pH and salt concentration were measured in the segments to the outer surface 1 and 3 and to the masonry surface in the segments 2 and 4 (see Fig. 29). The profile of salt concentration of chlorides and nitrates was measured higher in the outer (smooth) surface as expected. Sulphates showed a

different pattern than chlorides and nitrates as the sulphate concentration was high only at the original outer smooth surface. The reference (initial) concentrations were taken as the mean values of the concentrations from 1 and 3 segments and 2 and 4 segments for each reference stone.

Table 18 The initial salt concentrations, pH and water contents in the anode and cathode halves of the reference stone segments.

Reference stone segment	Outer (smooth) surface	Masonry (rough) surface	Outer (smooth) surface	Masonry (rough) surface	Outer (smooth) surface	Masonry (rough) surface
1	chlorides Cl^- [$\text{mg}\cdot\text{kg}^{-1}$]		pH		w [%]	
	1670±290	1190±50	7.2±0.8	6.9±0.9	0.3±0.0	0.3±0.1
	nitrates NO_3^- [$\text{mg}\cdot\text{kg}^{-1}$]					
	1140±80	880±80				
	sulphates SO_4^{2-} [$\text{mg}\cdot\text{kg}^{-1}$]					
890±40	90±14					
2	chlorides Cl^- [$\text{mg}\cdot\text{kg}^{-1}$]		6.9±0.4	6.7±0.0	0.2±0.0	0.2±0.0
	420±105	360±85				
	nitrates NO_3^- [$\text{mg}\cdot\text{kg}^{-1}$]					
	1000±240	660±115				
	sulphates SO_4^{2-} [$\text{mg}\cdot\text{kg}^{-1}$]					
540±370	20±10					

8.2.8 The results and discussion

The removal of the salts (chlorides, nitrates, sulphates) from the sandstones

From the initial concentration of salts (see Table 18) in the reference stone segments it is clear that the salt concentration significantly exceeded the limiting values from ÖNORM B 3355-1 [21] (see Table 5 to Table 7). Chlorides, nitrates and sulphates migrated towards the anode electrode by the electromigration. So the pattern of salt decreases was expected higher in the anode halves of the stone segments. At the end of the experiments 1, 2 and 3 the deviations in the efficiency of desalination were seen and the expected pattern was not obtained (see Fig. 32 to Fig. 34). Possibly non-homogeneous pore structure, uneven

distribution of the salts and short duration could have caused these deviations in the final concentrations.

Therefore the experiments were repeated with a longer duration. The repeated experiments 4, 5 and 6 showed the decreases in the salt concentrations related to the concentrations of the reference stone segment 2 after 10-11 days of an applied current and the expected patterns in consequence of the electromigration were obtained. The decreases of chloride, nitrate and sulphate concentrations reached to the low or below limiting values from the ÖNORM B 3355-1 [21]. The overall results from the experiments 4, 5 and 6 are shown in Fig. 35 to Fig. 37.

The average percentage decreases in the chloride, nitrate concentrations were higher in the anode halves in experiments 3, 5 and 6 in relation to the initial concentrations. In these experiments, the placement of the smooth (outer) surfaces of the stone segments with the higher salt concentrations was to the anode electrode, however, in the experiment 3 the decrease in the nitrate concentration was not high.

The deviation in the sulphate concentration could have been connected with an uneven distribution of the sulphates in the stones or with the inaccuracy of measurements. The sulphates have also different chemical and physical properties and therefore different results in the removal efficiency were expected. The initial sulphate concentration in the experiments 4, 5 and 6 were very low below limiting values from the ÖNORM B 3355-1 [21].

The transferred charge in the experiments 1, 2 and 3 was 864 C, in the experiments 4, 5 and 6 the transferred charge was 1728–1900 C. It was about 4–8 times less than in the previous experiments of the desalination conducted with the sandstones using the same clay poultice [36]. The transferred charge was insufficient and thus the increases might have helped for higher decreases in the salt concentrations.

Experiments 1, 2, 3 – duration 120 hours

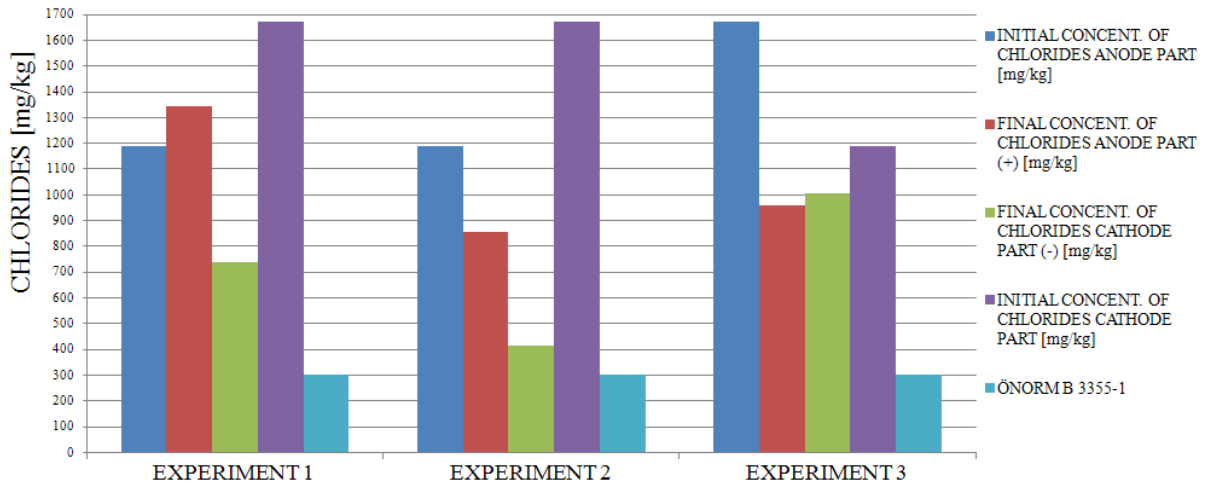

Fig. 32 The changes in the chloride concentration at the end of experiments 1, 2, 3.

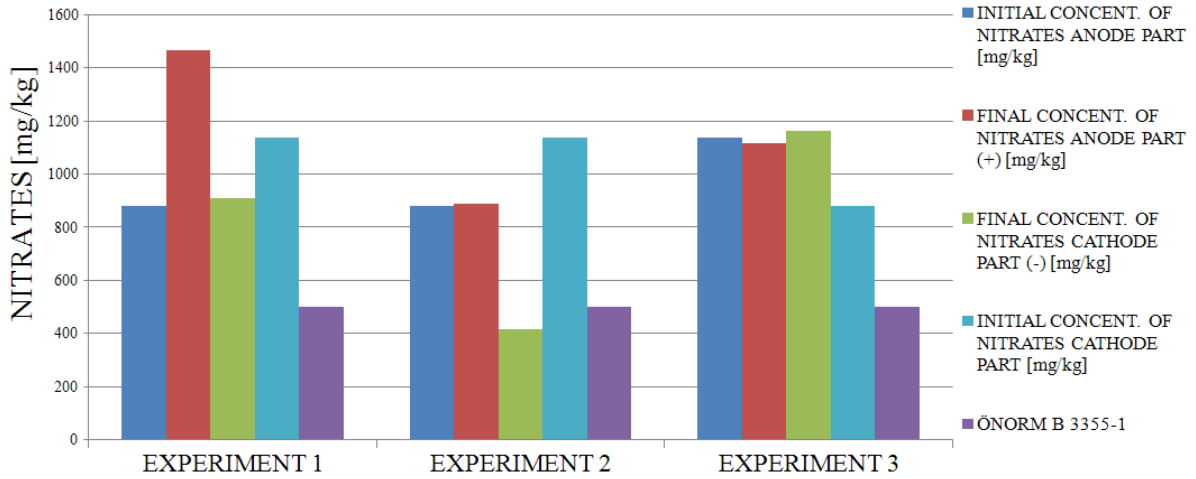

Fig. 33 The changes in the nitrate concentration at the end of experiments 1, 2, 3.

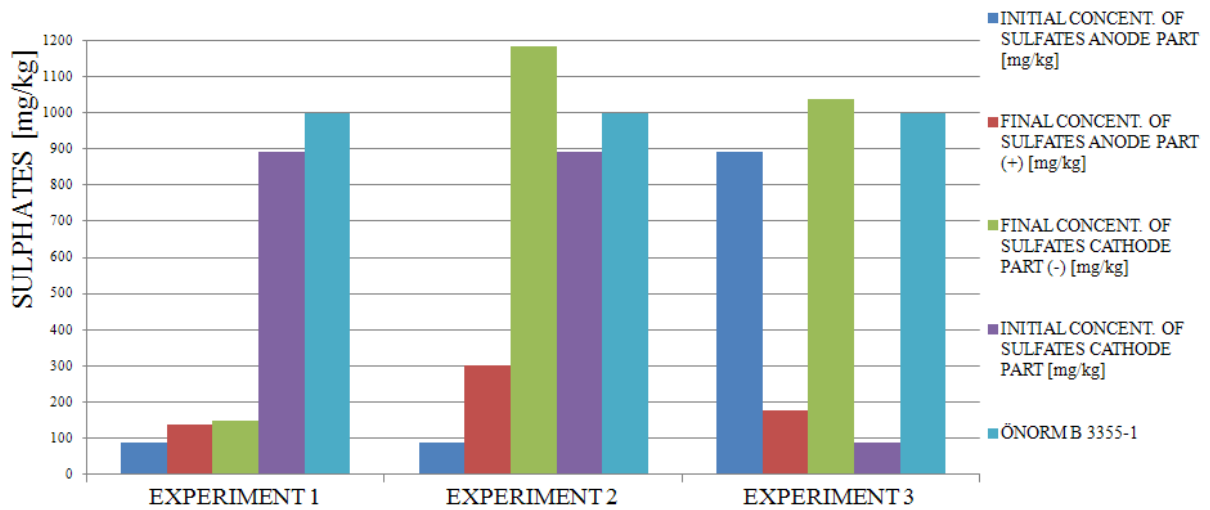

Fig. 34 The changes in the sulphate concentration at the end of experiments 1, 2, 3.

Experiments 4, 5, 6 – duration 240 and 264 hours

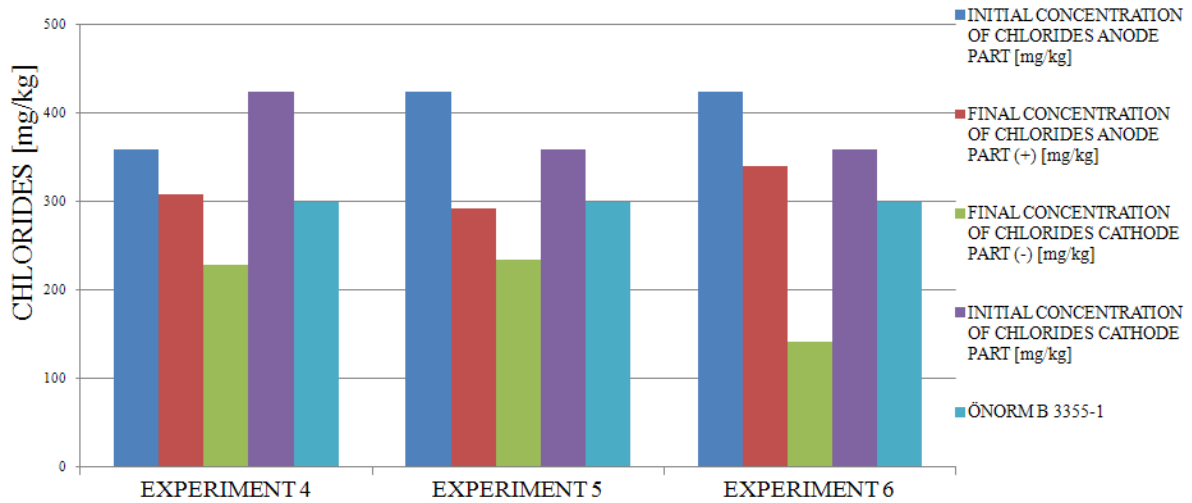

Fig. 35 The changes in the chloride concentration at the end of experiments 4, 5, 6.

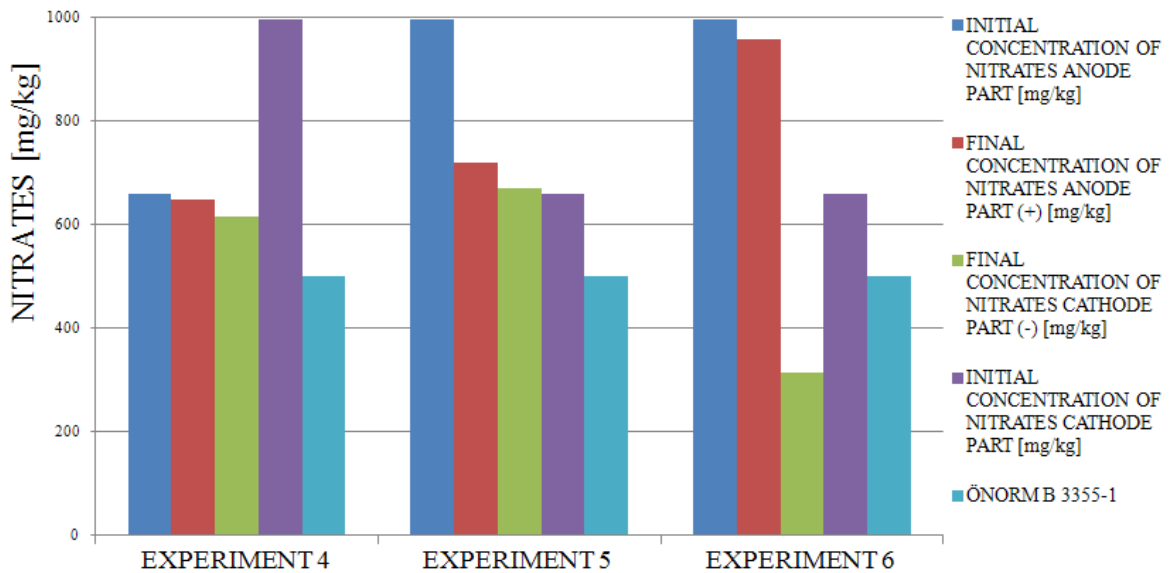

Fig. 36 The changes in the nitrate concentration at the end of experiments 4, 5, 6.

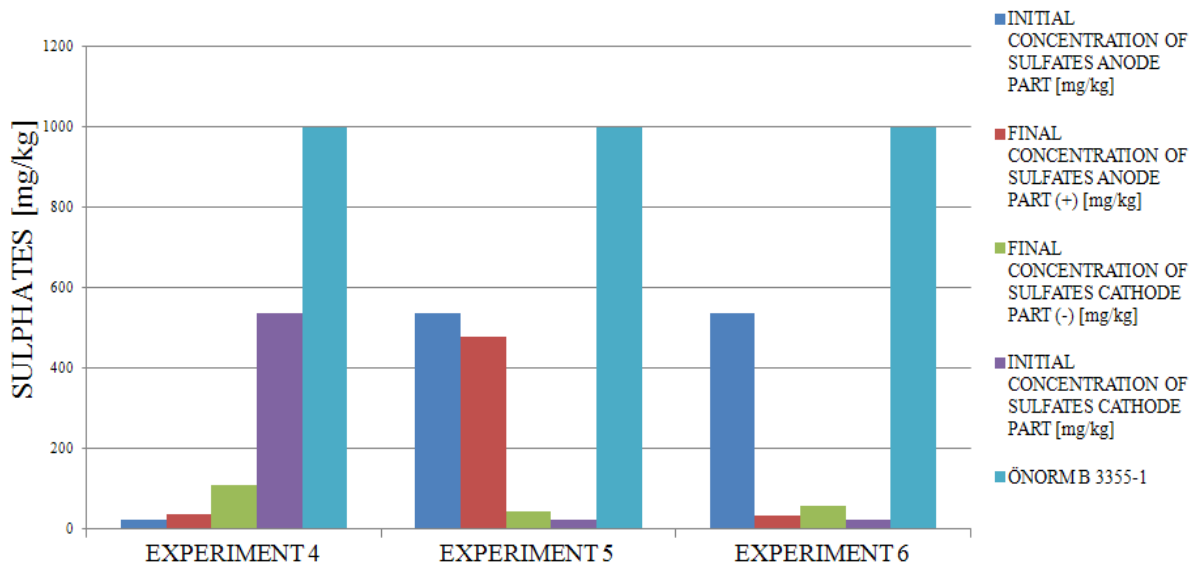

Fig. 37 The changes in the sulphate concentration at the end of experiments 4, 5, 6.

The salt concentration in the anode clay poultices

The Fig. 38 to Fig. 40 show the overall concentration of chlorides, nitrates and sulphates in the slices of poultices on the anode sides at the end of the experiments. The concentrations of salts in the cathode poultices are not shown because the concentrations were very little as the salt anions electromigrated towards anode.

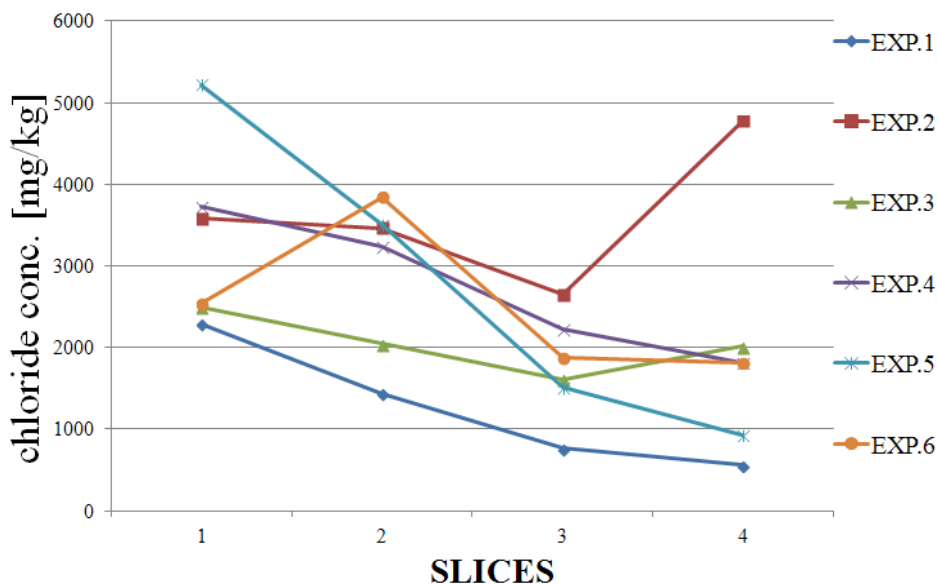

Fig. 38 The changes in the chloride concentration in the anode clay poultice at the end of experiments 1, 2, 3, 4, 5 and 6.

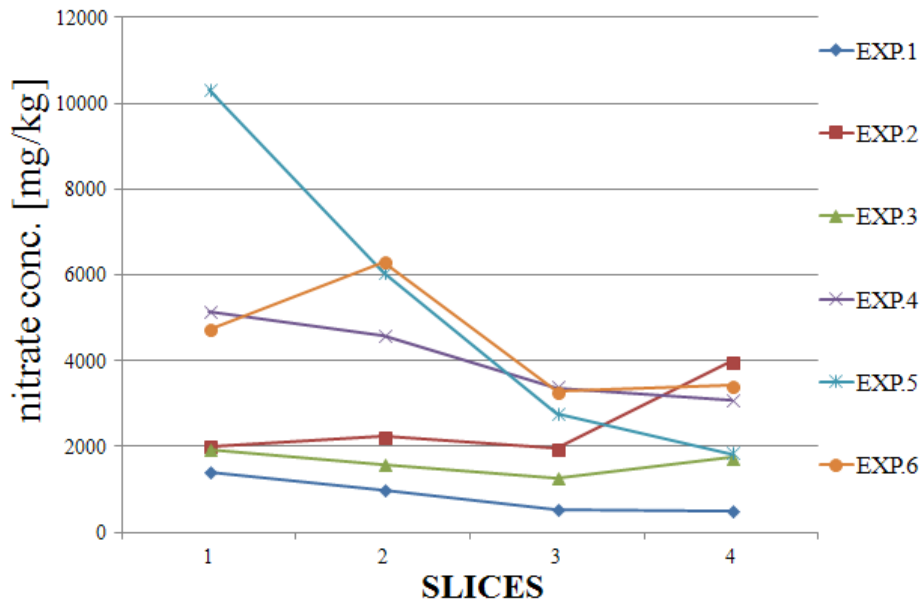

Fig. 39 The changes in the nitrate concentration in the anode clay poultice at the end of experiments 1, 2, 3, 4, 5 and 6.

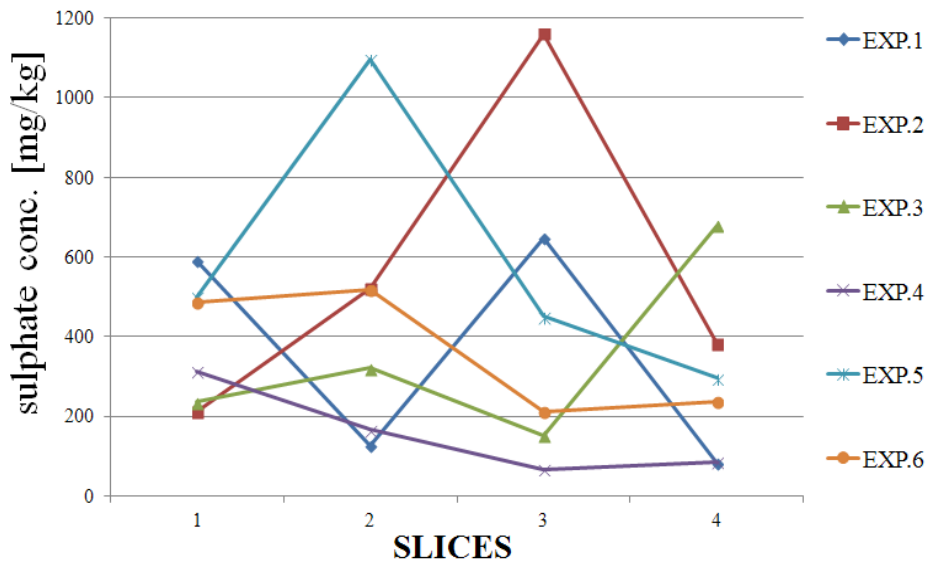

Fig. 40 The changes in the sulphate concentration in the anode clay poultice at the end of experiments 1, 2, 3, 4, 5 and 6.

Table 19 The anions of salts – removed mass, removal rate.

Exp.	Salts anions	Removed [g]	Removal rate [g·day ⁻¹]	Exp.	Salts	Removed [g]	Removal rate [g·day ⁻¹]
1	Cl ⁻	0.12	0.02	4	Cl ⁻	0.22	0.02
	NO ₃ ⁻	0.10	0.02		NO ₃ ⁻	0.33	0.03
	SO ₄ ⁻²	0.03	0.01		SO ₄ ⁻²	0.01	0.00
2	Cl ⁻	0.29	0.06	5	Cl ⁻	0.23	0.02
	NO ₃ ⁻	0.21	0.04		NO ₃ ⁻	0.42	0.04
	SO ₄ ⁻²	0.05	0.01		SO ₄ ⁻²	0.05	0.00
3	Cl ⁻	0.17	0.03	6	Cl ⁻	0.21	0.02
	NO ₃ ⁻	0.14	0.03		NO ₃ ⁻	0.37	0.03
	SO ₄ ⁻²	0.03	0.01		SO ₄ ⁻²	0.04	0.00

The resistivity and the duration of desalination

The duration of the experiments with the stone segments from the stone 2 was increased (10–11 days) compared to the experiments with the stone segments from the stone 1. Fig. 41 shows the overall changes in the voltage during the duration of the experiments 4, 5 and 6. At the beginning, the voltage differed slightly (between 12.5 V and 13.9 V). The voltage increased during the first day of these experiments but from the second day it had a decreasing tendency. During the third and the fourth day strong peaks of the voltage were measured in the experiments 4 and 5. It was caused by the problems with the contact. After the re-establishment of the anode electrode by hand, the voltage decreased significantly. Since then the voltage had an increasing tendency till the end of the experiments.

The longest experiment 6 had the problems with the contact in the seventh and the tenth day. The increasing tendency of the voltage demonstrated the Ohm's law. The resistance increased due to the increasing voltage. The increase in the voltage might have been result of the changes occurring on the electrodes during the experiments and because of drier anode clay poultice (read Electro-osmosis inside the clay poultices and the sandstones) but it might have been still possible to continue the experiments since the maximum voltage of the used power supply (Hewlett Packard E3612A, DC power supply) was not exceeded.

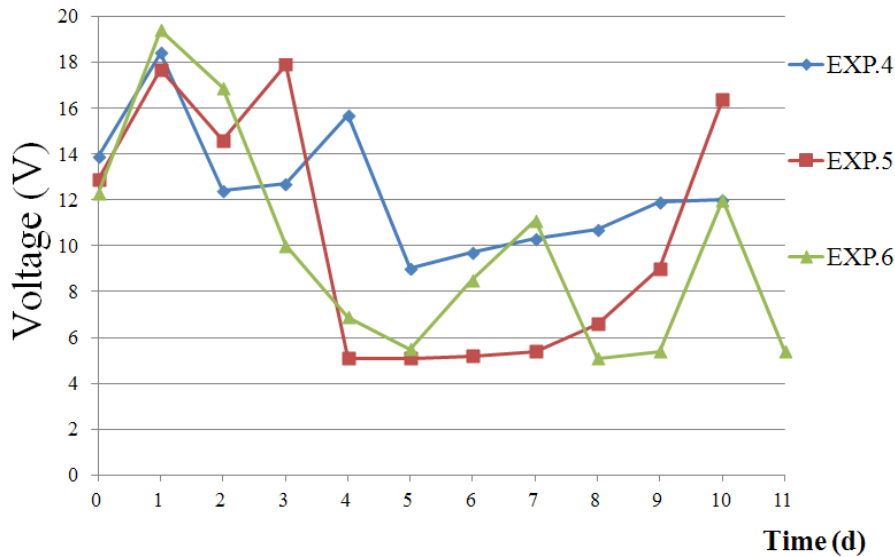

Fig. 41 The changes in the voltage during the experiments 4, 5 and 6 with the constant current 2 mA.

Electro-osmosis inside the clay poultices and the sandstones

The water contents in the clay poultice decreased at both anode and cathode side (see Table 20). In every experiment the clay poultice at the anode side had a lower water content than the clay poultice at the cathode (the difference was in the range of few percentages). The water (about 10 ml) was also seen under the clay poultices leaked to the underlay at the cathode side but never under the anode side. The drier anode clay poultice caused the increases in the resistance in the closed laboratory setup. The water contents of the two sides of the stones are very similar, however, a slightly higher water content was seen in the cathode part of some of the stones if not the same in both parts.

The overall tendency thus seems to be the water transport from the anode side to the cathode side. This may indicate electro-osmosis which is the movement of the water in a porous material under an applied electric field. The initial water contents in the reference stone segments were very low (see Table 18).

Table 20 The initial and final water contents in the stone segments and in the clay poultices at the end of the experiments.

Exp.	Init. water contents in the sandstones [%]	Final water content in sandstones		Initial water contents in the clay poultices [%]	Final water contents in the anode poultice [%]	Final water contents in the cathode poultice [%]
		Anode [%]	Cathode [%]			
1	1.9	1.8±0.1	2.1±0.2	45.0±0.3	31.6±0.2	33.1±1.4
2	2.1	2.1±0.1	2.1±0.1		29.9±0.34	33.2±0.4
3	1.5	1.4±0.2	1.7±0.0		32.2±0.07	36.0±0.5
4	1.3	1.1±0.1	1.1±0.1	43.0±0.4	25.0±0.9	27.0±1.5
5	1.6	1.5±0.1	1.5±0.0		31.0±1.2	31.7±0.5
6	1.7	1.5±0.2	2.2±0.1		30.0±2.1	34.0±0.2

The pH in the sandstones and in the clay poultices

An interesting finding was that the mixture used as poultice buffered the acidification from the anode process (read Electrode processes and Table 21) and thus it showed the suitability as poultice for the desalination processes. The initial pH of the reference stones without an applied electric field (see Table 18) were lower than pH in the segmented stone segments in every case at the end of the experiments.

The increased pH in the cathode halves of the stone segments was due to electrolysis at the cathode which resulted in OH⁻ production from the process (read 3.5 Electrode processes). The transport of OH⁻ through the stone segments by electromigration increased pH in the stone segments. The lower pH at the anode halves resulted in H⁺ production from the anode process (read 3.5 Electrode processes).

The changes in pH are dependent on the charge transfer and the duration of the experiments if the other conditions are the same as clear from the Table 21. Generally, the longer duration the higher increases in OH⁻ in the cathode halves of the stone segments and in the cathode clay poultices.

Table 21 Initial and final pH inside the stone segments and inside the clay poultices.

Epx.	Initial pH in the stone segments	Final pH in the stone segments		Initial pH in the clay poultices	Final pH in the anode poultice	Final pH in the cathode poultice
		Anode	Cathode			
1	7.2	7.8±0.1	7.6±0.1	8.7	8.2±0.1	10.8±0.1
2		8.0±0.2	8.7±0.1		8.4±0.2	10.8±0.2
3		7.9±0.1	7.4±0.2		8.3±0.1	11.0±0.0
4	7.1	7.9±0.1	9.2±0.3	8.8	8.1±0.1	11.3±0.2
5		7.7±0.2	9.8±0.2		8.0±0.1	11.2±0.1
6		8.1±0.2	10.0±0.1		8.3±0.1	11.2±0.2

8.2.9 The conclusion

The experiments were conducted with the salt contaminated sandstones from the historic warehouse. The concept of the electrokinetic desalination showed that the salt concentration could be reduced to the low concentrations.

- (1) In the segmented stones, the initial concentrations of chlorides (1670 and 425 mg·kg⁻¹) were reduced to values (410 and 140 mg·kg⁻¹); for nitrates from (1140 and 990 mg·kg⁻¹) to values (415 and 310 mg·kg⁻¹); for sulphates from (890 and 540 mg·kg⁻¹) to values (175 and 30 mg·kg⁻¹). The decreases in salt concentrations were within 5–11 days with 2 mA applied constant current, however, the concentrations were not decreased below limiting values in every case.
- (2) Electro-osmosis (movement of water) was proven, however, only in the clay poultice where the final water contents were significantly lower in the anode clay poultices than the final water contents in the cathode clay poultices. Inside the stone segments, the final water contents were similarly flat. These findings are in correspondence with the previous study [36]. Thus the used mixture as poultice showed the unsuitability for the dewatering of the segmented stones.

There might have been a slight flow of water through the sandstone caused by electroosmotically driven pressure from clay poultice to stone at the anode side and suction from the segmented stone to clay poultice at the cathode.

Too high initial water contents of the clay poultice might have been another problem for the dewatering of the segmented stones under the laboratory

conditions. The increases in the water contents in the sandstones may have also been caused by the amount of the water sprayed over the stones before the beginning of the experiments. Thus the tests of the clay poultices with the lower initial water contents might have been more efficient for the dewatering purpose.

- (3) The placement of the stone segments showed its importance in these desalination experiments.

At the end of the experiments the decreases in the salt concentrations were higher in the anode halves of the stone segments where the smooth surfaces of the stone segments were placed towards the anode. The shorter path for the salt anions towards the anode electrode might be an explanation for the higher decreases in the salt concentrations at the anode halves of the segmented stones but more experiments are needed to be done to verify these results.

- (4) The pH was lower in the reference stone segments than pH in the segmented stones at the end of the experiments (see Table 18 and Table 21). The used mixture as poultices showed suitability for desalination in relation to the pH changes and successfully neutralized the acidic front at the anode from electrolysis. The alkaline front at the cathode was high as a function of time.

Electromigration of OH^- from the cathode into the stone segments may be unwanted because it can influence the transport numbers of the targeted anions. Such decrease was seen in the electrochemical extraction of Cl^- from the concrete where OH^- ions from the cathode process became the main charge carriers [37]. Therefore the development of a clay poultice for the neutralization of the hydroxyl ions produced from the cathode reaction may increase the effectiveness of the desalination.

- (5) The removal rate and removed mass for chlorides, nitrates and sulphates were found out (see Table 19). These findings might have been useful for the further application in the future pilot test.

In general, the bad contact between the electrodes and the clay poultices was the main problem during the longer experiments therefore for the future tests it

would be necessary to improve the contact especially at the anode electrodes which were dried up.

8.3 The additional experiment to experiment 2

8.3.1 The main goals of the additional experiment

The main focus of the additional experiment is on:

- (1) to find out whether the higher constant current together with the more charge passed through the closed laboratory setup have any influence on the removal rate and removed mass of chlorides, nitrates, sulphates and thus on the decreases of the chloride, nitrate and sulphate concentrations in the sandstones,
- (2) to verify whether electro-osmosis (the water movement under an applied DC field) takes place more significantly when the stronger electric field is applied,
- (3) to confirm whether the placement of the sandstones (original outer surface) in relation to the electrodes has influence on the efficiency of the desalination when the stronger current is applied,
- (4) to find out the removed mass and removal rate for chlorides, nitrates and sulphates when the constant current is applied and to verify the suitability of the mixture used as the poultice in relation to pH changes.
- (5) from the obtained results to give recommendations for the application in the pilot test (read 9.4.3 The recommended setup for the desalination of the sandstone wall under an applied DC field using the clay poultices),

8.3.2 The experimental section

The sandstones for experiments

Two sandstones used in the laboratory experiments were taken from the same place as in the previous experiment 2. They were cut out from a larger stone which was damaged by the salts. The sandstones were about 0.5 m long, 5-7 cm thick and 10 cm high. They had grey colour (see Fig. 42 to Fig. 44). A relatively smooth surface of the sandstones had been the original outer surface and the

rough surface had been facing towards the wall. Lighter areas were clearly seen on the smooth surfaces of the stones 1, 2 (see Fig. 43 and Fig. 44). The stones were contaminated with unknown amount of the salt concentration. The two experimental stones (1 and 2) were weighed and the segmentation of the stones was done the same way as in the previous experiment (see Fig. 43 and Fig. 44). For the segmentation of the stones sawing was not used because this would add extra water to the stone segments which could cause a redistribution of the salts. After the segmentation, the desalination experiments were conducted with these stone segments.

In the laboratory experiments, one type of the clay poultice was used:

- a mixture of (calcite, kaolin and distilled water);



Fig. 42 Two stones used in experiments.



Fig. 43 Three segments of the stone 1. The stone segment 2 was used as reference.



Fig. 44 Three segments of the stone 2. The stone segment 1 was used as reference.

8.3.3 Materials for experiments

- the sandstones (Obernkirchen Sandstones);
- the rubber stoppers, the rubber tape bands;
- an adhesive tape;
- the plastic lids, vials, cylinders, the plastic film for wrapping;
- the electrode platinum covered from Permascand;

8.3.4 The analytical

The samples for the chemical analysis were prepared the same way as in the previous experiment 2. Fig. 45 shows the segmented parts of the closed laboratory setup where the water contents, pH and salt concentrations were measured. The reference stone segments were segmented into four pieces with which the same extractions as in the previous experiment 2 were done (see Fig. 45).

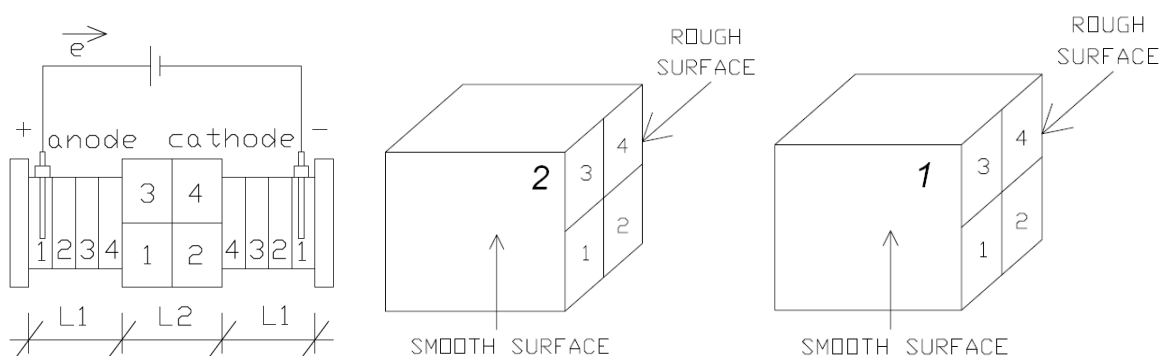

Fig. 45 The segmented parts of each laboratory compartment where the water contents, pH and the concentration of salts were measured. The reference stone segment 2 (fig. in the middle) was used for the experiments 1, 2. The reference stone segment 1 (fig. on the right) was used for the experiments 3, 4. Small numbers on the sides of the reference stones show the parts where the water contents, pH and salt concentrations were measured.

The reference stones

Because the stones are from a non-homogeneous natural material differences were expected. For the evaluation of the chlorides, nitrates and sulphates removal when an electric field was applied it was necessary to know the variation in the salt concentrations in the two reference stones. No water was added or DC field applied on the reference stone segments.

The water contents, pH and salt concentration were measured in the segments to the outer (smooth) surface 1 and 3 and to the masonry (rough) surface in the segments 2 and 4 (see Fig. 45). The profile of salt concentration of chlorides and nitrates was measured higher in the outer (smooth) surface as expected. Sulphates showed a different pattern contrary to the previous experiment as in the reference stone segment 2 the concentration of sulphates was similar in the outer (smooth) and masonry (rough) halves. The reference (initial) concentrations were taken as the mean values of the concentrations from 1 and 3 segments and 2 and 4 segments for each reference stone.

Table 22 The initial concentrations of the salts and the initial pH in the anode half and cathode half of the reference stone segments.

Reference stone segment	Outer (smooth) surface	Masonry (rough) surface	Outer (smooth) surface	Masonry (rough) surface	Outer (smooth) surface	Masonry (rough) surface
1	chlorides Cl^- [$\text{mg}\cdot\text{kg}^{-1}$]		pH		w [%]	
	1800±200	1560±90	7.8±0.2	8.4±0.5	0.12±0.0	0.19±0.1
	nitrates NO_3^- [$\text{mg}\cdot\text{kg}^{-1}$]					
	1650±210	1380±40				
	sulphates SO_4^{2-} [$\text{mg}\cdot\text{kg}^{-1}$]					
1680±40	160±20					
2	chlorides Cl^- [$\text{mg}\cdot\text{kg}^{-1}$]		7.4±0.2	7.9±0.2	0.1±0.0	0.1±0.0
	1650±540	1460±330				
	nitrates NO_3^- [$\text{mg}\cdot\text{kg}^{-1}$]					
	1150±310	1330±420				
	sulphates SO_4^{2-} [$\text{mg}\cdot\text{kg}^{-1}$]					
640±830	510±690					

8.3.1 The experimental setup

The laboratory closed setup for the electrokinetic desalination experiments is shown in Fig. 30. The two experimental sandstones were weighed and

segmented the same way as in the previous experiment to three segments each (see Fig. 43 and Fig. 44). After the segmentation, a known quantity of tap water was sprayed on the stone segments to supply the moisture to the pores. The reference stones were without any additional water. Submersion the stone segments in the water was not an option since salts could have been washed out.

The same experimental setup as in the previous experiments using the plastic cylinders was used. The difference in the laboratory setup was in the use of constant current which was set up 10 mA by a DC power supply (Hewlett Packard E3612A).

8.3.2 The experimental series

Four additional electrokinetic desalination experiments were conducted. The experiments are outlined in the Table 23 by the experimental conditions and by the placement of the stone segments in the relation to the electrodes (see Fig. 46). All experiments were conducted with the constant current of 10 mA except the experiment 1 where the initial constant current of 10 mA was changed for 2 mA after a day. The change in voltage was followed. A good contact during the duration of experiments was not maintained (read The results and discussion).

Table 23 The experimental conditions for the desalination experiments – duration, initial constant current, initial voltage, weight of the dried stone segments, initial water contents, placement of the stone segments (see Fig. 46).

Exp.	Duration [h]	Initial constant current [mA]	Initial voltage [V]	Weighted dried sandstone [g]	Initial water content [%]	Sandstone placement (Fig. 46)
1	360	10-2*	40.7	950.7	1.0	a)
2	217	10	38.1	1062.7	1.0	b)
3	238		50.3	1553.2	1.0	b)
4	260		57.7	878.4	1.0	a)

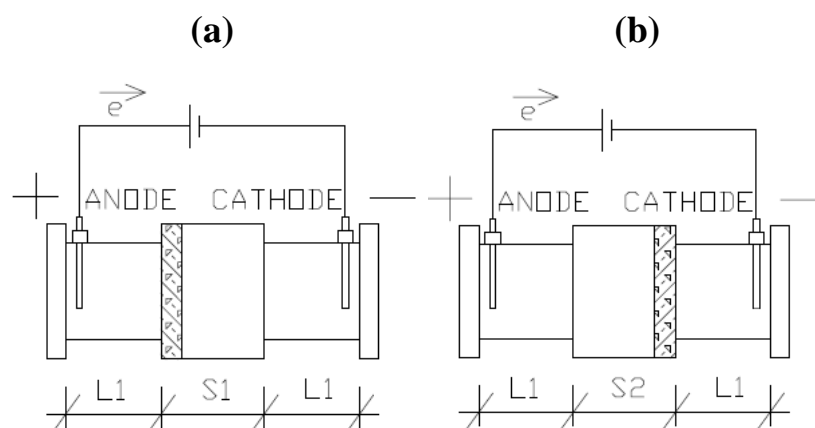

Fig. 46 The placement of the stone segments in relation to the electrodes.

- a) Original outer (smooth) surface towards the cathode; b) Original outer (smooth) surface towards the anode; L1 - the clay poultice; S1, S2 - the stone segments;

8.3.3 The results and discussion

Removal of the salts (chlorides, nitrates, sulphates) from the sandstones

From the initial concentration of salts (see Table 22) in the reference stones it is clear that the salt concentration significantly exceeded the limiting values from ÖNORM B 3355-1 [21]. At the end of the experiments 1, 2, 3 and 4 deviations in the desalination efficiency were seen. The decreases in chloride, nitrate and sulphate concentrations were high. In the experiments 1, 2 the average percentage decreases in chloride and nitrate concentrations in relation to the reference values were higher even when the overall charge that passed through the segmented stones was lower than in the experiments 3, 4. The overall results from the experiments 1–4 are shown in the Fig. 47 to Fig. 52.

Contrary to the previous experiments the higher mass of removed chloride and nitrate anions was measured in every of the additional experiment 1, 2, 3 and 4 (see Table 24). In the experiments 2, 3 and 4 the constant current of 10 mA was applied during the duration of the experiments. In the case of sulphates the removed mass was similar to the previous experiments.

The overall transferred charge in the experiments 1 was 3200 C, in the experiments 2, 3 – 7810, 8570 C and in the experiment 4 – 11800 C. The placement of the stone segments confirmed its importance from the previous experiment because the biggest mass of chlorides was removed in the

experiments 2 and 3 and the biggest mass of nitrates in the experiment 3 (see Table 24). The removal rate showed the velocity of migrated ions and confirmed the fact from the previous experiment (see Table 24). The velocity of sulphates was measured the least as expected.

Experiments 1,2,3,4

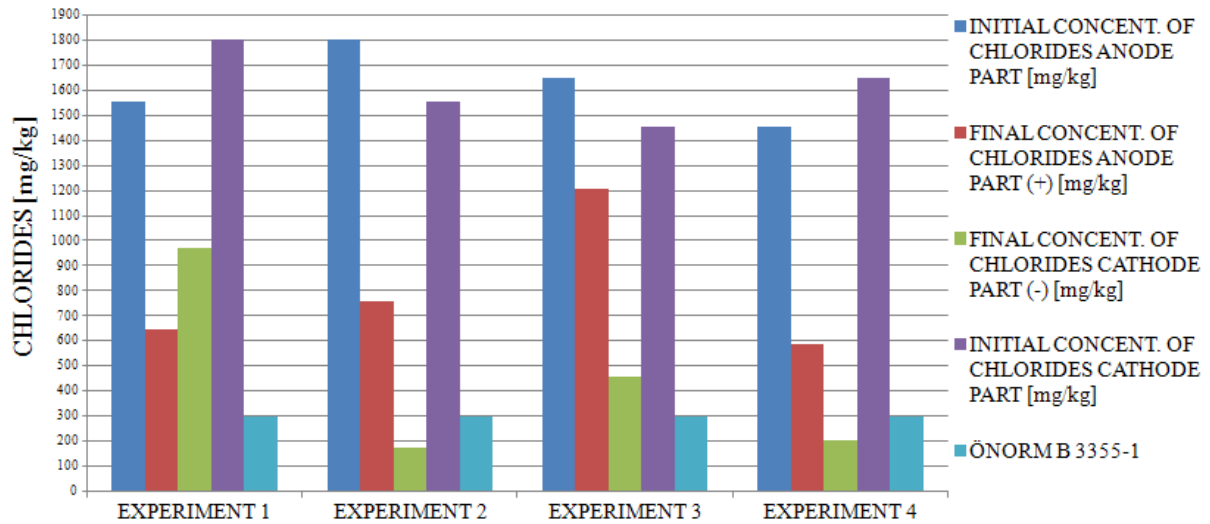

Fig. 47 The changes in the chloride concentration at the end of experiments 1, 2, 3, 4.

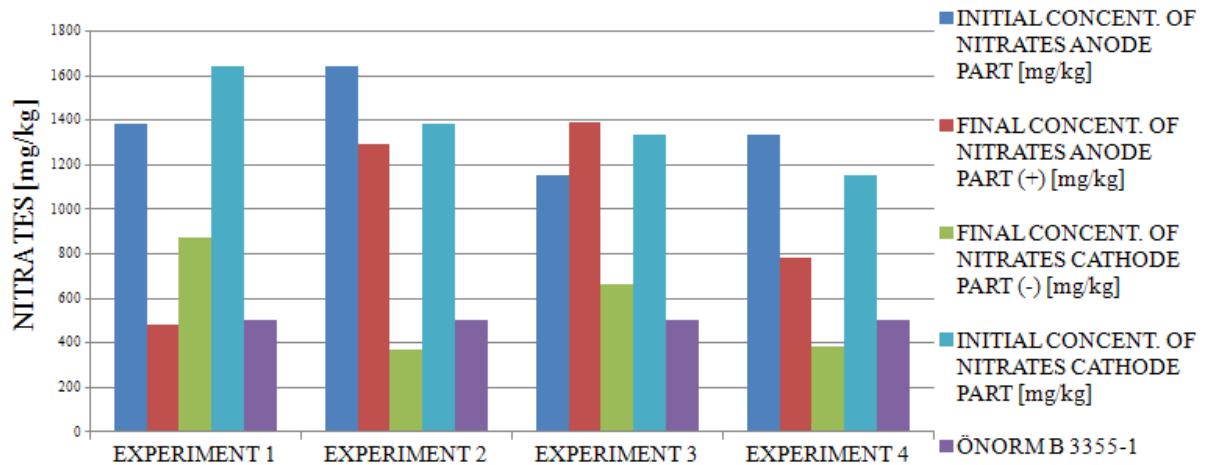

Fig. 48 The changes in the nitrate concentration at the end of experiments 1, 2, 3, 4.

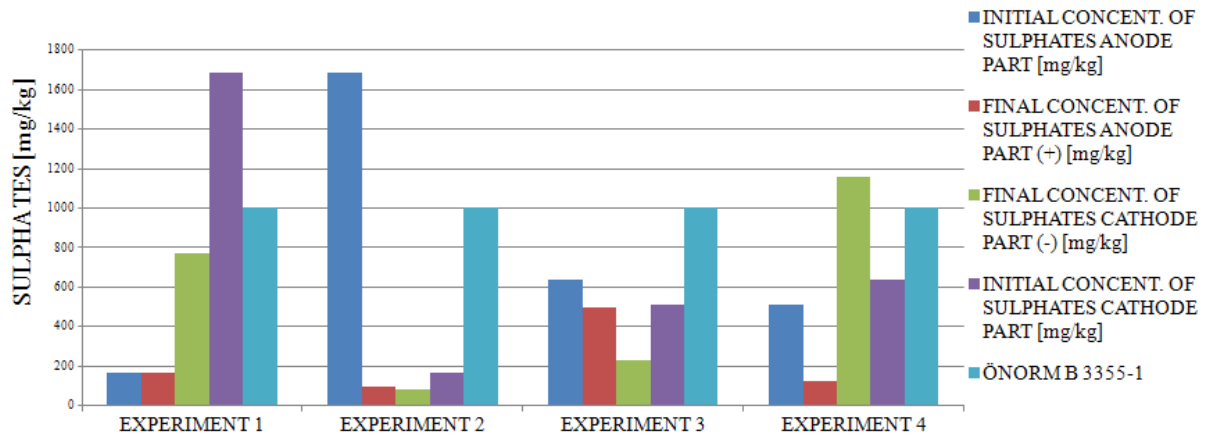

Fig. 49 The changes in the sulphate concentration at the end of experiments 1, 2, 3, 4.

The salt concentration in the anode clay poultices

The Fig. 50 to Fig. 53 show the overall concentration of chlorides, nitrates and sulphates in the slices of poultices on the anode sides at the end of the experiments. The concentrations of salts in the cathode poultices are not shown because the concentrations were very little as the salt anions migrated towards anode.

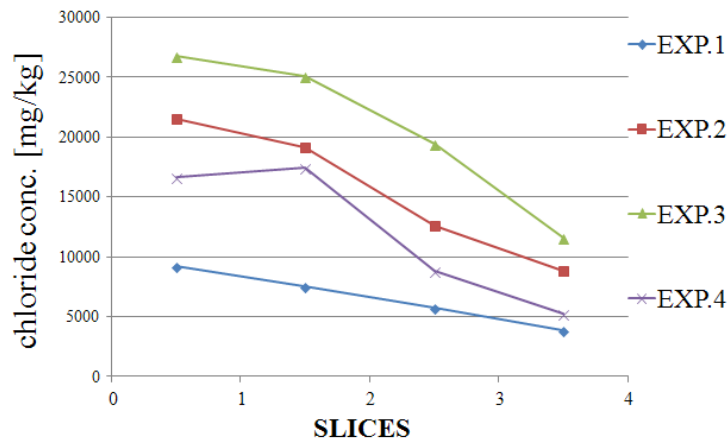

Fig. 50 The changes in the chloride concentration in the anode clay poultice at the end of experiments 1, 2, 3, 4.

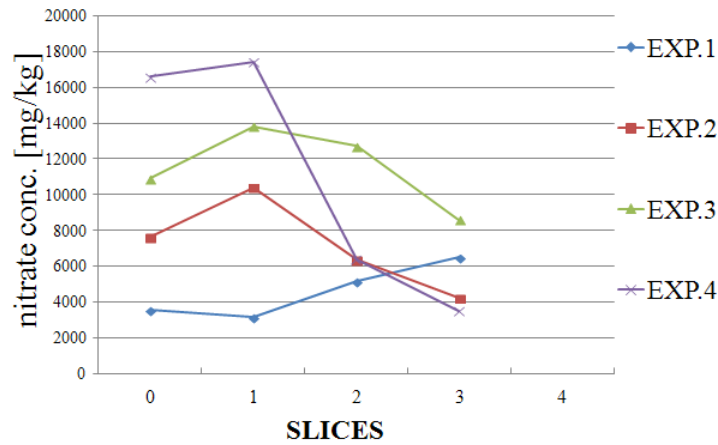

Fig. 51 The changes in the nitrate concentration in the anode clay poultice at the end of experiments 1, 2, 3, 4.

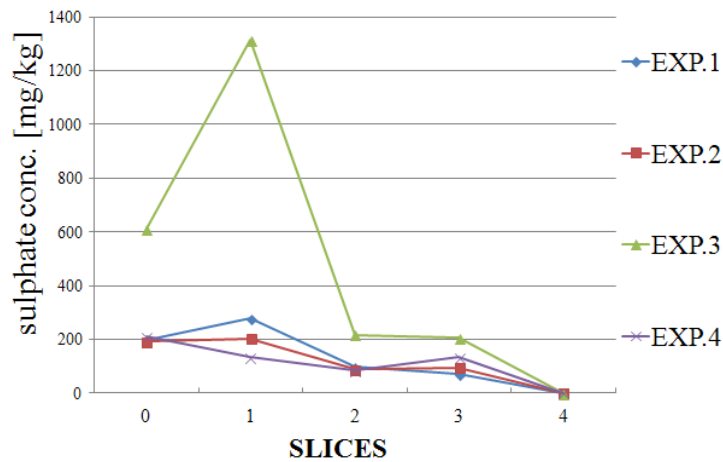

Fig. 52 The changes in the sulphate concentration in the anode clay poultice at the end of experiments 1, 2, 3, 4.

Table 24 The removed mass and the removal rate of chlorides, nitrates, sulphates at the end of experiments.

Exp.	Salt anions	Removed [g]	Removal rate [g·day ⁻¹]	Exp.	Salt anions	Removed [g]	Removal rate [g·day ⁻¹]
1	Cl ⁻	0.81	0.05	3	Cl ⁻	1.66	0.17
	NO ₃ ⁻	0.52	0.10		NO ₃ ⁻	0.93	0.09
	SO ₄ ⁻²	0.07	0.01		SO ₄ ⁻²	0.05	0.00
2	Cl ⁻	1.25	0.14	4	Cl ⁻	0.97	0.09
	NO ₃ ⁻	0.58	0.06		NO ₃ ⁻	0.58	0.05
	SO ₄ ⁻²	0.01	0.00		SO ₄ ⁻²	0.01	0.00

The resistivity and the duration of the desalination

The duration of the experiments with the stone segments from the stones 1, 2 was (9–15 days). Fig. 53 shows the changes in the voltage during the duration of the experiments 1, 2, 3 and 4.

At the beginning of the experiments, the voltage differed between 38 V and 58 V. The voltage in the experiment 1 increased after the first day to the maximum voltage of the power supply so it was decided to decrease the constant current from 10 mA to 2 mA. Then the voltage decreased to 58.3 V. The following day the problem with too high resistance occurred and the electrodes had to be fixed by hand to establish a good contact again. The experiment 1 operated maximally for five days in a row without any necessary correction of contact. However, the maximum value of voltage was reached at the end of experiments thus the experiment was stopped.

The experiment 2 was influenced by the bad contact from the second day of the experimental duration and from then the contact had to be established every day at least once. In the experiment 3 the problem with the bad contact started from the second day of the experimental duration and the longest duration without any correction was three days in a row.

The longest experiment 4 had the problems with the contact from the third day of the experimental duration. Then the problems with the bad contact occurred every day till the end of the experiment. The increase in the voltage might have been due to changes occurring on the electrodes during the experiments and also because of drier anode clay poultice (read Electro-osmosis inside the clay poultices and sandstones). It was possible to continue the experiments since the maximum voltage of the used DC power supply (Hewlett Packard E3612A) was not exceeded at the end of the experiments.

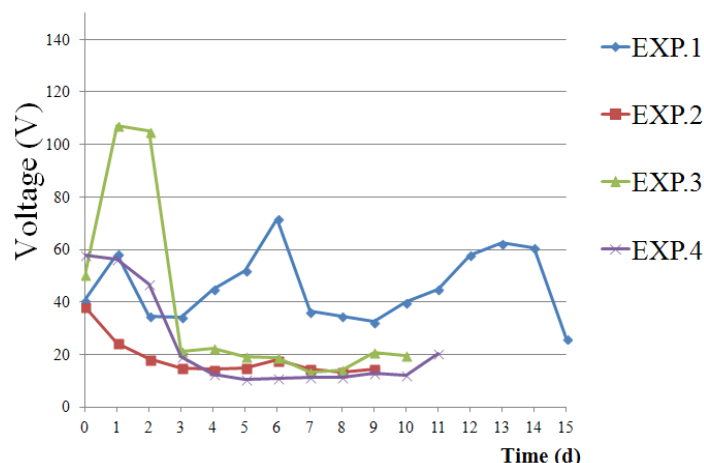

Fig. 53 The changes in the voltage during the experiments 1, 2, 3 and 4 with a constant current.

Electro-osmosis inside the clay poultices and in sandstones

The water contents in the clay poultices decreased in both anode and cathode clay poultice (see Table 25). In every experiment the clay poultice had a lower water content at the anode side than poultice at the cathode at the end of experiments.

The initial water contents in the reference stone segments were very low (see Table 22). The final water contents of the two halves of the segmented stones are very similar, however, a slightly higher water content was seen in the cathode part if not the same in both parts at the end of experiments (see Table 25). The overall tendency thus seems to be the transport of water from the anode side to the cathode side. These findings are in correspondence with the previous experiments. The increases in the water contents in the stone segments may have been caused by the amount of the water sprayed over the stones before the beginning of the experiments and by the water from the mixture which contained a lot of water.

Table 25 The Initial and final water contents in the stone segments and in the clay poultrices.

Exp.	Initial water content in the sandstones [%]	Final water content in the sandstones [%]		Initial water contents in the clay poultrices [%]	Final water contents in the anode poultrice [%]	Final water contents in the cathode poultrice [%]
		Anode	Cathode			
1	1.0	1.7±0.3	1.7±0.1	44.2±0.1	21.4±0.6	31.7±0.9
2	1.0	1.6±0.1	2.0±0.1		30.6±0.7	34.1±0.4
3	1.0	1.9±0.1	2.1±0.3	44.1±0.1	29.2±1.1	33.7±0.5
4	1.0	2.0±0.1	2.2±0.1		30.5±0.8	33.7±0.5

The pH in the sandstones and in the clay poultrices

As in the previous experiments, the mixture used as the clay poultrice buffered the acidification from the anode process (read 3.5 Electrode processes and Table 26). The initial pH of the reference stones without an applied electric field (see Table 22) were lower than pH in the segmented stones in every case at the end of experiments. The increased pH in the cathode halves of the stone segments was due to electrolysis at the cathode which resulted in OH⁻ production from the process (read 3.5 Electrode processes - cathode electrolysis). The transport of OH⁻ through the stone segments by electromigration increased pH in the stone segments. The lower pH at the anode halves resulted in H⁺ production from the anode process.

Table 26 The initial and final pH inside the stone segments and inside the clay poultrices.

Exp.	Initial pH in the segmented stones	Final pH in the segmented stones		Initial pH in the clay poultrices	Final pH in the anode poultrice	Final pH in the cathode poultrice
		Anode	Cathode			
1	8.1±0.1	7.9±0.0	8.8±0.6	8.6±0.1	8.0±0.1	11.6±0.2
2		8.4±0.6	10.2±0.1		8.5±0.2	11.6±0.2
3	7.7±0.3	8.5±0.7	10.6±0.0	8.9±0.1	8.3±0.1	11.0±0.0
4		9.3±0.7	10.6±0.2		8.1±0.1	11.3±0.2

8.3.4 The conclusion

The additional experiments were conducted with the salt contaminated sandstones from a historic warehouse. The concept of the electrokinetic desalination of problematic salts followed the previous experiment with sandstones. Electrokinetic treatment showed that the concentration could be reduced to the low concentrations. During the experiments with duration from (9 to 15 days) the initial concentration of chlorides, nitrates and sulphates were decreased significantly to the low concentrations and in the cases of sulphates, the decreases were below limiting values of concentrations from ÖNORM B 3355-1 [21].

- (1) In the stone segments, the initial concentrations of chlorides (1800 and 1550 mg·kg⁻¹) were reduced to values between (1200 and 175 mg·kg⁻¹); for nitrates from (1650 and 1150 mg·kg⁻¹) to values between (1390 and 370 mg·kg⁻¹); for sulphates from (1680 and 510 mg·kg⁻¹) to values between (170 and 95 mg·kg⁻¹). The decreases in the salt concentrations were within 9–15 days with 10 mA applied constant current and in the experiment 1 with 2 mA.
- (2) The movement of the water was clearly seen, however, only in the clay poultice the water movement was significant. The highest difference in the water decreases was in the experiment 1 that had the longest duration.

The used mixture as the clay poultice showed the unsuitability for the dewatering in the segmented stones because the decreases in the water contents clearly do not indicate electro-osmosis within the segmented stones at the end of experiments. The wrapping of the segmented stones with the plastic film was possibly one of the limiting factors for more significant dewatering as in the previous experiment.

- (3) The placement of the stone segments confirmed its importance from the previous results because the biggest mass of chlorides (1.3–1.7 g) was

removed in the experiments 2, 3 and in the case of nitrates, the removed mass was the biggest in the experiment 3 (0.9 g).

- (4) The removal rates of salt anions were found out and confirmed the supposed velocity of migrated ions (see Table 24).

Even when the experiments 2, 3 did not have the longest duration and the highest amount of charge passed through, the removal rate for chlorides and nitrates was the highest. Possibly, the relatively good contact during the duration of experiments contributed to these results. Also shorter path for salt anions towards the anode electrode from the place with the higher concentration of salts might be the explanation for the higher removal rate of certain salts. The used clay poultices confirmed their suitability in relation to the pH changes and successfully neutralized the acidic front at the anode from electrolysis.

- (5) The encourage results of desalination (removal rates of chlorides and nitrates) were used in the following recommendations for the desalination of the sandstone wall.

8.4 EXPERIMENT 3 – Desalination of the bricks contaminated with the sodium chloride under an applied electric field

8.4.1 Introduction

The experiment 3 was aimed at the desalination of the bricks contaminated with the sodium chloride solution. The experiment 3 was conducted with the use of technique of clay poultices placed externally with the use of electric field. Two types of clay poultices were tested in the combinations with the halves of bricks. The experiment tightly follows the previous work [38].

8.4.2 The goals of the experiment 3

The experiment 3 was focused on:

- (1) to find out which combination of the clay poultices has the highest efficiency in decreases of the chloride concentration,
- (2) to find out which combination of tested clay poultices has the highest decreases in the water contents inside the bricks at the end of experiments,

- (3) to find out which combination of the clay poultices creates the least amount of OH⁻ ions in the cathode clay poultice,

8.4.3 The experimental section

The same type of Danish yellow bricks of the dimensions 22.8 cm · 10.8 cm · 5.4 cm were used in the present laboratory experiments (see Fig. 14). These were taken from Wienerberger's brickfield. The porosity of these bricks was about 28.0 % as in the previous experiment 1. Every experiment was conducted with 2 halves of a brick. In the laboratory experiments, two types of clay poultices were used (see Fig. 14).

- a mixture of (calcite, kaolin and distilled water or tap water) – the tap water was used only in the experiment 2;
- the brick clay – it contained approximately 17.0 – 18.0 % of carbonates (date from Wienerberger's brickfield);

8.4.4 Materials for experiments

- the yellow Danish bricks;
- the rubber stoppers, the rubber tape bands;
- an adhesive tape;
- the plastic lids, vials, cylinders, the plastic film for wrapping;
- the electrode platinum covered from Permascand;

8.4.5 The analytical

In the present work, the water soluble fraction in the distilled water is relevant for the measurement. Before analysis, the halves of bricks were segmented the same way as in the previous experiment 1 (see Fig. 16).

Inside these segmented slices the water contents and pH were measured. The water content was found by the weigh and dry method (drying for 24 hours at 105 °C) and calculated as (water/dry mass) · 100 %. The dried samples of the clay poultices were powdered in a mortar by hand and the bricks in a mechanical mortar. The fine powder was suspended – 10 g of the powder in 25 ml of the

distilled water in the plastic vials, which were placed on an agitating table for 24 hours. After this pH was measured with electrodes directly in the suspensions with pH meter (PHM 220 Lab pH Meter). The suspensions were then filtered through 0.45 μm filter under vacuum. The concentration of chlorides was then measured with titration method (716 DMS Titrino). The mean values of the water contents, pH and the chloride concentration inside the bricks and inside the clay poultices were calculated with the standard deviations.

8.4.6 The experimental setup

At the beginning of the experiment, the whole brick was put into the oven for drying overnight. The next day, the whole dried brick was segmented with the hammer and the chisel by hand to 2 similar halves. Every half of the brick was completely submerged into the NaCl solution for 4 days (see Fig. 54). The solution contained 52.5 g of NaCl in 3.5 L of the distilled water (0.26 M NaCl). After the submersion, the two halves of the brick were weighed again. Every experiment was conducted with 2 such saturated halves of the brick.

The laboratory setup with the use of the plastic cylinders filled with clay poultices was set up the same way as in the experiment 1 (read 8.1.6 The experimental setup). Finally, a constant current was applied to the electrodes by a DC power supply (Hewlett Packard E3612A). The laboratory closed setup is shown in Fig. 54.



Fig. 54 The used yellow brick contaminated with NaCl solution (left) and the used closed laboratory setup (right). The wrapping is not shown. [39]

8.4.7 The experimental series

Overall five electrokinetic experiments were conducted. Every experiment was conducted with two halves of the brick. The experiments are outlined in Table 27 by the experimental conditions.

Table 27 The initial conditions of the experiments: the combinations of poultices, the duration, the initial constant current, the initial voltage, the weight of dried halves of the bricks, the initial water contents of halves of bricks. TW - the tap water; DW – the distilled water; BR1 - half 1; BR2 - half 2; KAOL. - kaolin; [39]

Exp.	Poultice ANODE	Poultice CATHODE	Duration [h]	Current [mA]	Voltage [V]	Weight of dried brick [g]	Water contents [%]
1	(CaCO ₃ + DW + KAOL.)	(CaCO ₃ + DW + KAOL.)	240	10	BR1 = 9.1; BR2 = 9.1	1173.8; 1084.9	16.5; 16.2
2	(CaCO ₃ + TW + KAOL.)	(CaCO ₃ + TW + KAOL.)			BR1 = 7.9; BR2 = 7.9	1203.7; 1045.4	17.5; 17.1
3	BRICK CLAY	BRICK CLAY			BR1 = 7.0; BR2 = 7.0	1116.6; 1073.6	18.9; 19.0
4	(CaCO ₃ + DW + KAOL.)	BRICK CLAY			BR1 = 7.8; BR2 = 7.8	1109.4; 1071.9	16.9; 17.7
5	BRICK CLAY	(CaCO ₃ + DW + KAOL.)			BR1 = 8.3; BR2 = 8.3	1125.6; 1083.7	17.3; 16.4

8.4.8 The results and discussion

The reference bricks

It must be taken into account that the differences in the initial water contents inside the halves of the bricks were measured even though bricks were taken from the same batch. It is seen from the initial water contents inside the halves of the bricks after submersion for 4 days into the sodium chloride solution (see Table 27).

For measurements of chloride concentration, two dried halves of the brick were submerged for 4 days into the NaCl solution. After this period of submersion, the chloride concentration inside the halves of the brick was measured. These values of the concentration were taken as the reference for the

chloride measurements (see Table 28). The reference bricks were without application of DC electric field.

Table 28 The reference blind halves of the brick submerged for 4 days into the NaCl solution: the reference initial concentration of chlorides, the initial pH, the initial conductivity; BR.1,2 – the halves of the brick; [39]

Halves of brick	chloride concentration [mg·kg ⁻¹]	pH	conductivity [μS·cm ⁻¹]
BR.1	1130	10.7	1390
BR.2	1000	10.6	1000

The removal of chlorides from the bricks

From the initial reference blind halves of the brick (see Table 28), it is clear that the chloride concentration exceeded the limiting values from ÖNORM B 3355-1 [21] significantly.

The initial chloride concentration (1130 and 1000 mg·kg⁻¹) was reduced the most significantly to below limiting values in the experiments 1, 2 (see Fig. 55). This corresponds to the mean chloride decreases inside the bricks about (95–100 %) in the experiment 1 and about (80–94 %) in the experiment 2. The decreases in the chloride concentration were high in the experiment 3 as well. Inside the half 1 of the brick, the mean chloride decrease was even 100 %, however, inside the half 2 the mean chloride decrease was only about 70 %, moreover, the decrease of chloride concentration inside the anode half of the brick was not to below the limiting values (see Fig. 55). The similar pattern of the deviation was seen also in experiments 4, 5 (see Fig. 55). The segmented samples of the anode sides of the bricks were re-measured but even after the repetition of the measurements the deviations were confirmed. [39]

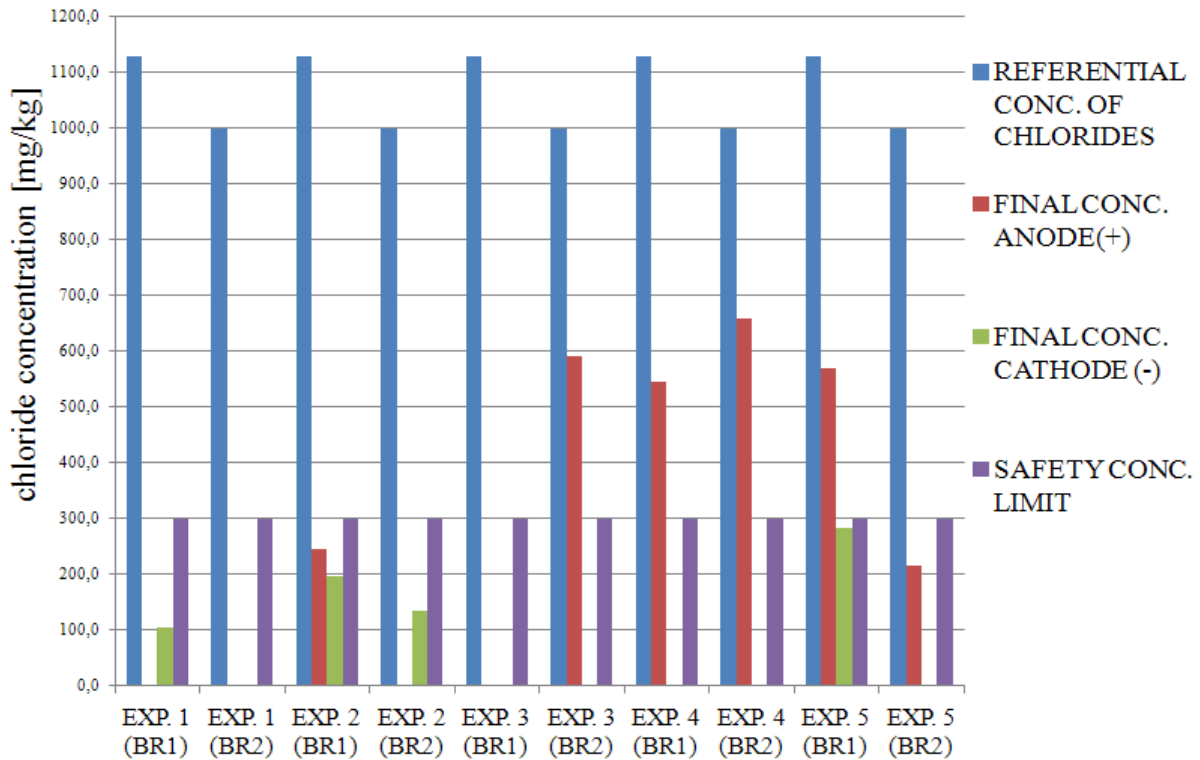

Fig. 55 The changes in the chloride concentration inside the halves of the bricks at the end of the experiments. [39]

Electro-osmosis inside the bricks and in the clay poultrices

In every experiment the transport of the water was clearly seen since the higher water contents were obtained in the cathode halves of the bricks (see Fig. 56 and Fig. 57), moreover, the clay poultrices at the anode side had a lower water contents contrary to the poultrices at the cathode side in every experiment (see Table 29). The leaked water (about 10 ml) was also seen under the cathode clay poultrices on the underlay but never under the anode side. These signs clearly indicate the electroosmotic flow inside the laboratory setup. Table 29 shows the overall changes in the water contents inside the clay poultrices in all experiments.

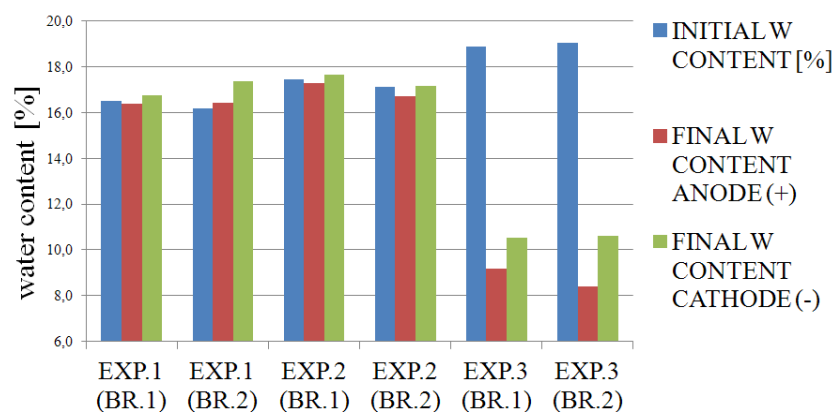

Fig. 56 The changes in the water contents inside the halves of the bricks at the end of experiments 1, 2 and 3. BR.1 – half 1; BR.2 – half 2; [40]

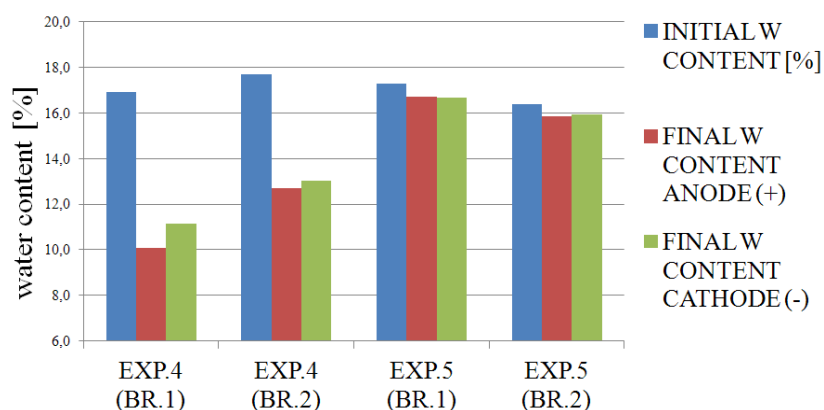

Fig. 57 The changes in the water contents inside the halves of the bricks at the end of experiments 4, 5. BR.1 – half 1; BR.2 – half 2; [40]

Table 29 The changes in the water contents inside the clay poultices: the initial water contents, the final water contents on the anode and cathode sides. DW – distilled water; TW – tap water; KAOL. – kaolin; [40]

Poultice type	Initial water contents [%]	Poultice ANODE [%]	Poultice CATHODE [%]
Brick clay	19.3–21.5	13.6–18.0	21.0–21.2
mixture (CaCO ₃ + KAOL. + TW)	43.4–44.5	34.0–36.4	37.4–38.7
mixture (CaCO ₃ + KAOL. + DW)	42.5–44.8	30.5–36.4	36.3–39.0

The pH inside the bricks and in the clay poultices

In every experiment, the clay poultices buffered successfully to decrease the pH below 7 which means acidification (see Fig. 58 and Fig. 59). Generally, the pH was lower at the anode poultice than at the cathode poultice in every experiment. These facts support the suitability of the tested clay poultices for the

electrokinetic desalination. Table 30 shows the overall changes in pH inside the clay poultices at the end of experiments.

The pH changes inside the bricks

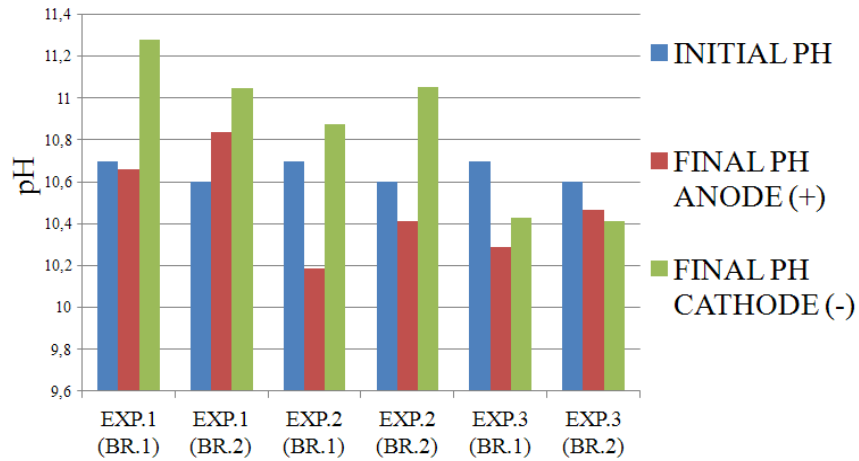

Fig. 58 The changes in pH inside the halves of the bricks at the end of the experiments 1, 2 and 3. BR.1 – half 1; BR.2 – half 2; [40]

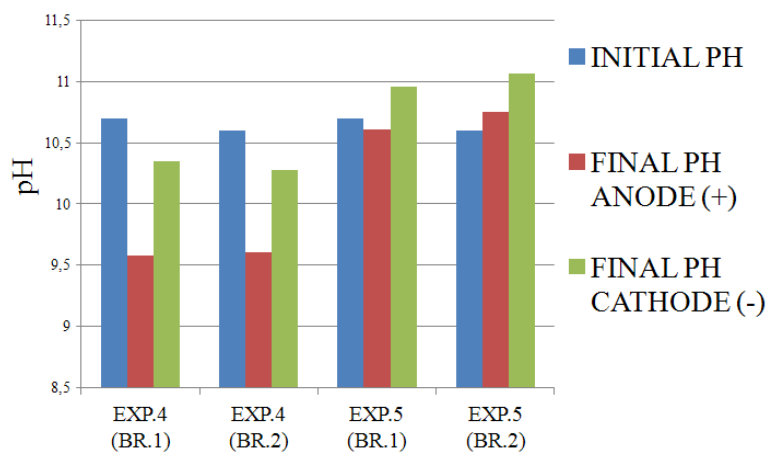

Fig. 59 The changes in pH inside the halves of the bricks at the end of the experiments 4 and 5. BR.1 – half 1; BR.2 – half 2; [40]

Table 30 The changes in pH inside the clay poultices: the initial pH, the final pH at the anode and cathode sides. TW – the tap water; DW – the distilled water; KAOL. – kaolin; [40]

Poultice type	Initial pH	Poultice ANODE	Poultice CATHODE
Brick clay	7.9–8.2	7.2–7.4	10.7–11.0
mixture (CaCO ₃ + KAOL. + TW)	7.5–7.8	7.9–8.0	10.9–11.0
mixture (CaCO ₃ + KAOL. + DW)	8.8–8.9	8.3–9.0	10.9–11.3

8.4.9 The conclusion

The experiments were conducted with one type of yellow bricks which were submerged in the sodium chloride solution for 4 days. The initial concentration of chlorides was decreased significantly to very low concentration under an applied electric field within 10 days.

- (1) The combination with the mixture as clay poultices used on the both sides showed the highest decreases in the chloride concentration between (80–99 %) in relation to the initial concentration of chloride. The final decreases in chloride concentration were below to limiting value.

Other combinations showed the deviations in the decreases of the chloride concentrations and thus the unsuitability for the use. The solution how to avoid these deviations and to improve the decreases in the chloride concentration with these combinations might have been in changes of the clay poultices after some period of time. That action might have removed the chlorides soaked into the poultices and helped to re-establish good contacts at electrodes which are needed for the current flow and thus for the process of desalination.

- (2) The combination with the brick clay as the clay poultices on the both sides showed the highest decreases in the water contents inside the bricks from the initial water contents (18.9 and 19.0 %) to the final average water contents (9.9 and 9.5 %).

The mixture used as the clay poultices contained a lot of water and that was probably the main reason, why the water contents did not decrease below the initial water contents in the experiments 1 and 2. The pressure/suction effect could have influenced the electro-osmosis as well.

- (3) The combination with the brick clay on the anode sides and the mixture on the cathode side showed the lowest increases of pH in the cathode poultice (24.3–24.6 %) in relation to the initial value of pH (8.8) of the clay poultice.

Every tested combination of the clay poultices buffered the acidification successfully.

8.5 EXPERIMENT 4 – Desalination of a masonry in the pilot test under an applied electric field

8.5.1 Introduction

The present pilot test follows tightly the previous studies [32] [41] where the similar electrode units were tested for the purpose of electrokinetic desalination. The results from the previous study showed encourage results in the decreases of chloride concentration but the electrode units were quite unpractical because of making other useless holes into the masonry when they were applied on a wall. Therefore it was difficult to change the clay poultices for the new ones. The present investigation is conducted with new utilized electrode units (see Fig. 61). Desalination of masonry is aimed at three the most common type of salts: chlorides, nitrates and sulphates. The electrode units filled with the brick clay were used externally putting on the wall of an old stable.

8.5.2 The goals of the experiment 4

The main goals of the pilot scale test are:

- (1) to find out the efficiency of the desalination such as the removal rate, removed mass of chlorides, nitrates and sulphates when the clay poultices and the constant current were applied,
- (2) from the obtained results to give recommendations for the application in the pilot test (read 9.4.2 The recommended setup for the desalination of the brickwork with the plaster when an electric field is applied),

8.5.3 The experimental section

The stable for the pilot test

The pilot scale test was conducted on the wall of the old stable. It was seen that the wall of the stable was suffering from the plaster peeling because the fixed areas of the plaster were seen (see Fig. 60). It was expected that the stable was build from the Danish bricks connected with the lime-cement mortar and the lime-cement plaster with the different thickness.



Fig. 60 The reference old stable for the pilot test.

8.5.4 The materials for experiment

- the rubber tape bands;
- an adhesive tape;
- the metal net electrodes;
- the brick clay from Wienerberger's brickwork with approximately 17.0–18.0 % of carbonates;
- wood;

Electrode units – specification

The electrode units consist of white plastic casings, movable plastic bottom, metal net electrodes, metal springs, plastic heads, (see Fig. 61), power supply (Hewlett Packard E3612A, DC power supply) and wooden support construction (see Fig. 63). The rubber tape band was placed on the edges of the plastic casings.



Fig. 61 The electrode unit – the movable bottom, the mesh electrode, the springs, the plastic heads, the rubber tape band.

8.5.5 The analytical

Before the chemical analysis, the initial masonry samples taken from the wall were examined for the water contents and concentration of salts. The water contents were found by the weigh and dry method (drying for 24 hours at 105 °C) and calculated as $(\text{water/dry mass}) \cdot 100 \%$. Then the dried powder was suspended – (dry mass) 10 g of powder in 25 ml of distilled water in the plastic vials, which were placed on an agitating table for 24 hours. The suspensions were then filtered through 0.45 μm filter under vacuum. The concentrations of chlorides, nitrates and sulphates were measured with the ion chromatography in the laboratory. The same procedure was done with every examined sample.

8.5.6 The experimental setup

The mesh metal electrodes were put on the movable bottom inside the plastic casings (see Fig. 61). These two plastic casings serve further as electrode units. The rubber tape bands were pasted on the edges of the boxes. That prepared casings were filled with the brick clay up to the edges of the rubber tape bands. One electrode unit served as the anode the other as the cathode. The wooden support construction was used because the plastic casings did not have any holes for screws and therefore the construction had to support them. That was the difference in comparison with the casings used in the previous study. The plastic casings were put into the wooden construction and pressed to the wall (see Fig. 62 and Fig. 63). After pressing, the metallic springs were put outside the casings and the plastic heads screwed these springs inside. This action pressed the brick clay which was filled in the plastic casings tightly to the masonry. Thus a good contact between the brick clay and the masonry was maintained. A good contact is essential for electrokinetics. Finally, the constant current was set up (Hewlett Packard E3612A, DC power supply).

8.5.7 The experimental series

The initial samples were drilled from the different heights (30, 60, 90, 120, 150 cm) above the ground between the supposed placement of the electrode units.

After drilling, the electrode units were placed on the wall. For the intention of the desalination the constant current was adjusted. The distance between the electrodes was 1 m from the beginning but it was changed to 0.5 m. The upper edge of the electrode units was at the height 150 cm above the ground. The values of current and voltage were followed every day of the pilot test. At the beginning of the pilot test, the problem with so fast voltage increases was found out. The voltage had such a quick increasing tendency in consequence of the masonry resistance because the wall was dry too much. Therefore the tap water was sprayed on the wall. The voltage decreased suddenly in consequence of the lower resistance. The area around the electrode units was then wrapped with a plastic to hinder evaporation of the water (see Fig. 62). It helped to prolong the duration of the brick clay as poultice to be changed. When the voltage got maximum of the power supply (Hewlett Packard E3612A, DC power supply) the brick clay was changed for a new one. After every change, the brick clay was segmented to 3 parts on the anode side and on the cathode side (see Fig. 63) in which the concentration of salts was measured.



Fig. 62 The placement of the electrode units on the wall, wooden construction and the area of the wrapping in the second stage.

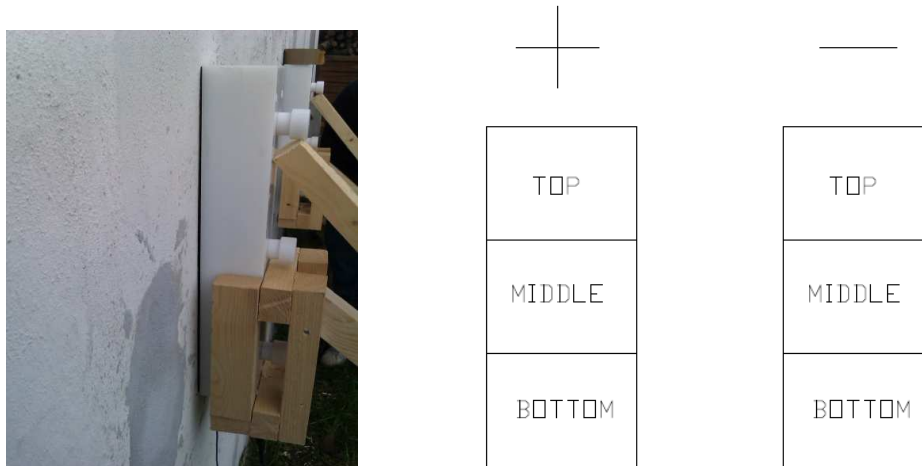

Fig. 63 The detail of the setup on the wall and the segmented parts of the units, where the concentration of salts was measured after every change of the brick clay.

8.5.8 The results and discussion

The removal of the salts (chlorides, nitrates, sulphates) from the masonry

From the initial concentration of salts (see Table 31), it is clear that the salt concentration significantly exceeded the limiting values from ÖNORM B 3355-1 [21]. The utilized electrode units decreased the concentration of chlorides, nitrates and sulphates in the masonry at one location. The brick clay inside the units was changed 8 times during the pilot test. The new brick clay was placed on the same place and the experiment continued. The longest period with the same brick clay was a month, however, the problems with a high masonry resistance occurred in this period. The overall transferred charge was 88 900 C at the end of the pilot test. It corresponds to 10 mA current applied into the wall within 3.5 months. Every change of the clay poultices is shown in the Fig. 64 to Fig. 66 together with the removed mass of chlorides, nitrates, sulphates and the transferred charge. Another problem was during the winter. The temperatures decreased below zero and the pilot test had to be stopped for 2.5 months because the brick clay was frozen and thus the maximum voltage was reached quickly due to the high resistance of the frozen clay. The whole duration of pilot test was thus 6 months. The overall results of the water contents and salt concentrations from the pilot test are shown in the Table 31 to Table 33.

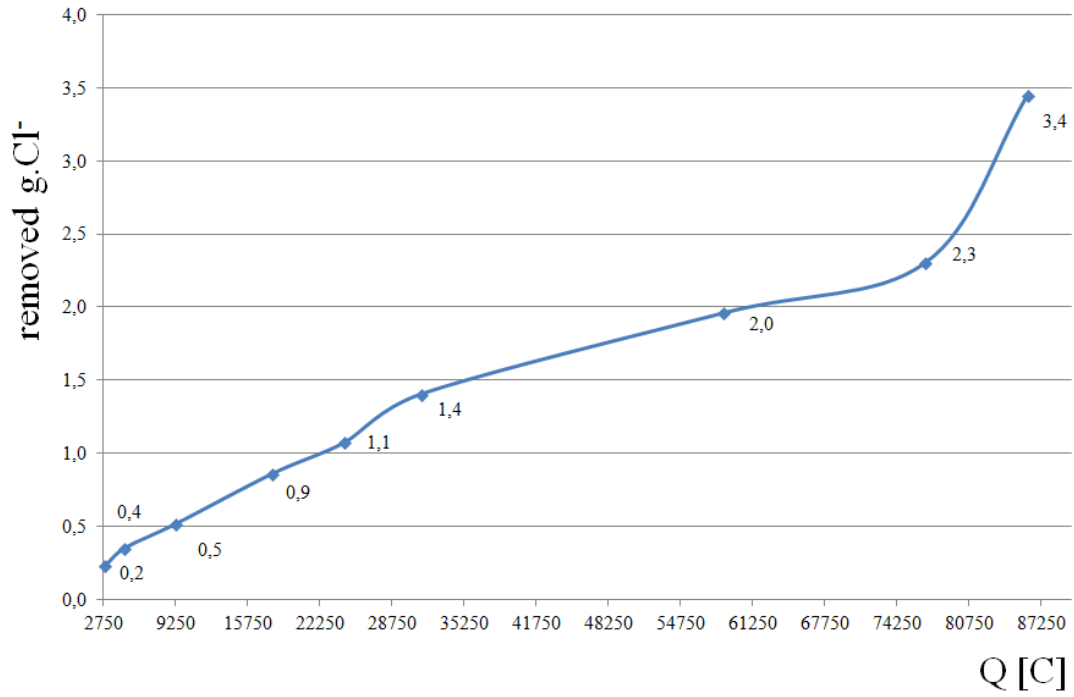

Fig. 64 The removed grams of chlorides after every change of the clay poultice.

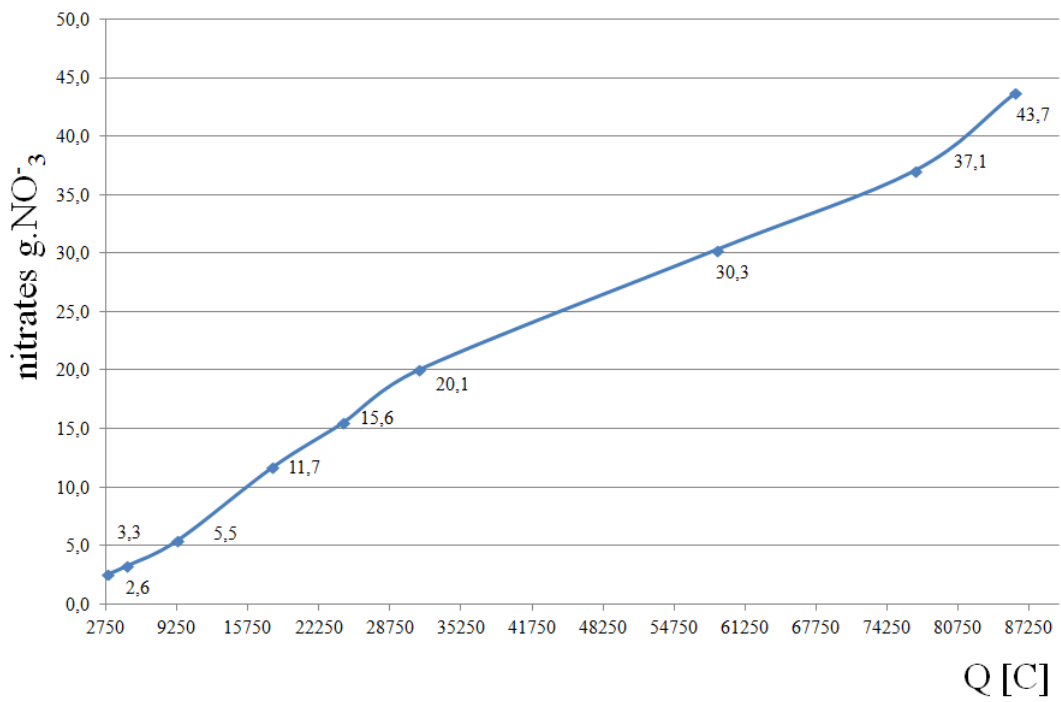

Fig. 65 The removed grams of nitrates after every change of the clay poultice.

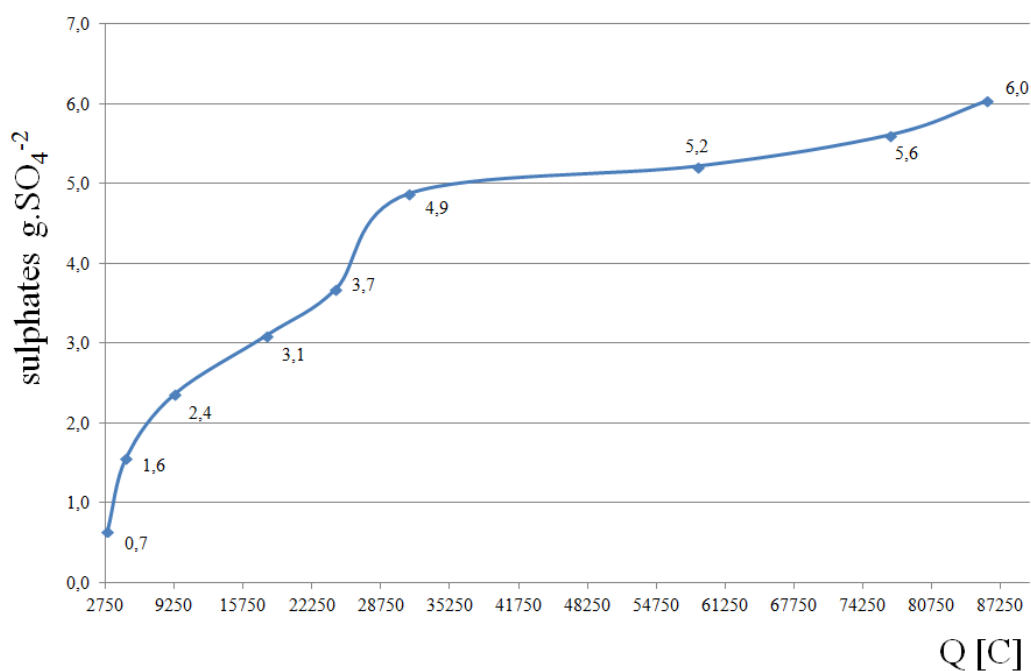

Fig. 66 The removed grams of sulphates after every change of the clay poultice.

Table 31 The mean initial concentration of chlorides, nitrates and sulphates in the masonry based on the salt concentrations examined from the initial samples, the duration of the constant current applied to the set of the electrodes.

Salt anions	Initial concentration [mg·kg ⁻¹]	Duration [months]	Current [mA]
Cl ⁻	700±360	3.5	10
NO ₃ ⁻	19600±9050		
SO ₄ ⁻²	1600±1130		

Table 32 The removed mass of chlorides, nitrates, sulphates, the mean final concentration in the wall and the removal rate of chlorides, nitrates, sulphates.

Salt anions	Removed [g]	Final concentration [mg·kg ⁻¹]	Rate [g·day ⁻¹]
Cl ⁻	3.4	420±160	0.03
NO ₃ ⁻	43.7	16000±7800	0.40
SO ₄ ⁻²	6.0	640±570	0.05

Table 33 The initial and the final water contents in the initial samples measured in the different heights above the ground.

Samples (height)	Initial water content w [%]	Final water content w [%]
30 cm	4.4	1.9
60 cm	1.8	6.5
90 cm	3.9	7.3
120 cm	5.3	7.3
150 cm	4.6	5.4

8.5.9 The conclusion

The pilot test and tested utilized electrode units showed that the electrokinetic method worked in relation to the decreases of salt concentrations. The problems with too high resistance of the masonry were solved by spraying the tap water on the wall and wrapping the area around the electrode units with the plastic.

Nevertheless, the addition of extra water inside the wall is unwanted. It is seen that the water contents of the samples taken at the end of the pilot scale test were higher contrary to the initial water contents at the beginning especially in the heights (90, 120, 150 cm) between the electrode units (see Table 33).

- (1) The efficiency of the desalination was found out. At the end of the pilot test, the initial concentration of chlorides ($700 \text{ mg}\cdot\text{kg}^{-1}$) was reduced to the value ($420 \text{ mg}\cdot\text{kg}^{-1}$), the initial concentration of nitrates ($19600 \text{ mg}\cdot\text{kg}^{-1}$) to value ($16000 \text{ mg}\cdot\text{kg}^{-1}$) and the initial concentration of sulphates from ($1600 \text{ mg}\cdot\text{kg}^{-1}$) to the value ($640 \text{ mg}\cdot\text{kg}^{-1}$). The removed mass and removal rates are shown in Table 32.

In the case of sulphates, it was successful to decrease the initial concentration below the limiting value which means no damage, however, the duration of the experiment was too short to obtain sufficiently lower concentration of chlorides and nitrates.

- (2) From the obtained results following recommendations for the application in the pilot test are given.

9 CONCLUSION AND FINDINGS OF SCIENTIFIC KNOWLEDGE

9.1 The optimization of the closed laboratory setup for the dewatering of the tap water saturated bricks due to electro-osmosis using different types of the clay poultices

On the basis of the experimental drying of the tap water saturated bricks under the laboratory conditions the most suitable combination of the clay poultices for the dewatering due to electro-osmosis was found out.

- The tested combination of the clay poultices where the brick clay as poultice was used on the both sides showed the highest decreases in the water contents at the end of the laboratory experiments (read 8.1.9 The conclusion).
- The same combination showed the lowest increases in pH in the cathode clay poultice (read 8.1.9 The conclusion).
- The both types of tested clay poultices showed their buffering capacity in relation to the changes of pH in every experiment (read 8.1.9 The conclusion).

9.2 Desalination of the sandstones under the laboratory conditions using one type of clay poultice

On the basis of the experimental electrokinetic desalination of sandstones under the laboratory conditions, the efficiency of desalination was found out, moreover, the suitability of the used clay poultices for desalination was verified.

- The tested clay poultices in which the mixture (CaCO_3 + kaolin + distilled or tap water) was used on the both sides showed significantly high decreases in the chloride, nitrate and sulphate concentrations at the end of the desalination experiments (read 8.2.9, 8.3.4 The conclusions).
- The tested mixture buffered the acidification in every experiment with the sandstones (read 8.2.9, 8.3.4 The conclusions).

- The placement of the electrodes in relation to the sandstone surfaces with the different salt concentration showed its importance. The higher removed mass and removal rates of chlorides and nitrates were calculated when the anode electrodes were placed towards the sandstone surface with the higher concentration of salts. The importance of the placement was confirmed in the additional experiment where the stronger current was applied into the electrodes (read 8.3.4 The conclusion).

9.3 The optimization of the closed laboratory setup for the desalination of the bricks contaminated with sodium chloride using the different types of clay poultices

On the basis of the experimental desalination of the bricks contaminated with the sodium chloride under the laboratory conditions the most suitable combination of the clay poultices for the desalination was found out.

- The tested combination of clay poultices where the mixture (CaCO_3 + kaolin + distilled or tap water) was used on the both sides showed the highest decreases in the chloride concentration in the bricks at the end of the laboratory experiments (read 8.4.9 The conclusion).
- The combination with the brick clay on the both sides showed the highest decreases in the water contents inside the bricks (read 8.4.9 The conclusion).
- The both types of the tested clay poultices showed their buffering capacity in relation to pH changes in every experiment (read 8.4.9 The conclusion).

9.4 The use of the electrokinetics for the desalination of constructions such as brickwork and sandstone walls

In the present building practice, the electrokinetics as the method for the dewatering and desalination of the building matters and construction is successfully used. The method of dewatering due to electro-osmosis has been used mainly in Germany, Austria, Denmark for decades and many of the equipments in these countries have been already certified, however, the method

for drying and desalination may be sorted as an expensive because of the rising prices of energy. The last chapters are written on the basis of laboratory results and results from the pilot tests.

9.4.1 The choice of the suitable type of the clay poultice

The choice of the suitable type of the clay poultice is an essential for the dewatering and desalination. The right choice influences the efficiency of the dewatering significantly.

The dewatering of the bricks and the brickwork

- For dewatering of bricks and brickwork, the brick clay used as the clay poultice showed the highest decreases in the water contents from the water saturated bricks. The used brick clay should contain approximately 17.0–18.0 % of carbonates.
- The setup of the constant voltage and good contact should be maintained.

9.4.2 The recommended setup for the desalination of the brickwork with the plaster when an electric field is applied

From the experiment 4 (read 8.5 EXPERIMENT 4 – Desalination of a masonry in the pilot test under an applied electric field) and from the previous pilot scale test [42] the approximate effectiveness in the desalination of the two types of clay poultices was found out.

The following recommendations for desalination are based on the results from the pilot scale tests and the experience obtained from them. The specific conditions such as the initial water contents, initial concentration of salts and the outer temperature have to be taken into account.

The following points describe the way how to set up electrode units for the desalination of the brickwork properly in order to get the highest efficiency for desalination:

- To have the visual survey and the knowledge from the history of the building – to find out the sources of the moisture and salts,
- To design a solution which avoids moistening of the construction,

Fig. 67 shows the area of a wall which should be desalinated.

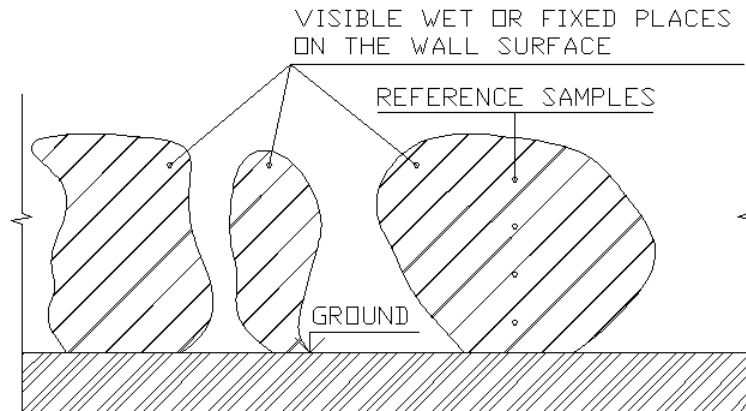

Fig. 67 The simplified scheme of a part of a wall which has to be desalinated.

- To think about the future placement of the electrode units. The same type of the electrode units as in the experiment 4 are supposed to use for the desalination purpose,
- The supposed placement of the electrode units on the brick wall (see Fig. 68 and Fig. 69),

A.....the recommended distance between the used electrode units (350–500 mm) given from the experimental results,

B..... the height of the used electrode units (500 mm),

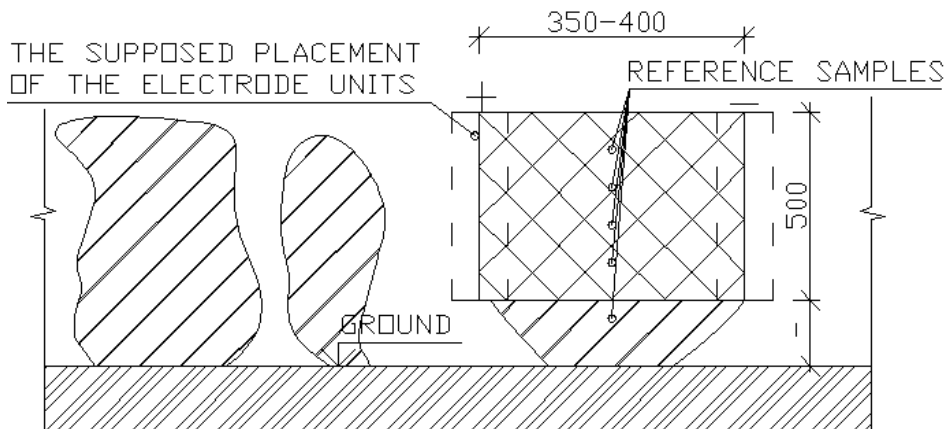

Fig. 68 The area from where the initial (reference) samples were taken (drilled).
Dashed lines – the supposed placement of the electrode units;

- To take the initial (reference) samples from the wall between the supposed placement of the electrode units (see Fig. 68),

- To take the reference samples by drilling in the brickwork from the different heights above the ground and to analyse the initial water contents and the initial salt concentrations. The samples should be taken from the whole depth of the brickwork. In general, it is supposed that the salts are distributed in higher concentrations at the outer surface of the brickwork between the layer of a plaster and bricks,
- The finding of the salt concentrations in the whole cross section of the wall may be useful for better placement of the electrode units and thus for the improvement of the efficiency of desalination,
- From the ion chromatography, the initial concentration of chlorides, nitrates and sulphates may be calculated:

The initial concentration of Cl^- [$\text{mg}\cdot\text{kg}^{-1}$]
 The initial concentration of NO_3^- [$\text{mg}\cdot\text{kg}^{-1}$]
 The initial concentration of SO_4^{2-} [$\text{mg}\cdot\text{kg}^{-1}$]

- The next step is the placement of the electrode units on the wall and set up of constant current. The electrode units should be placed on the same side of the brick wall where the higher concentration of salts is. The Fig. 69 shows the suitable placement of the electrode units on the brickwork,

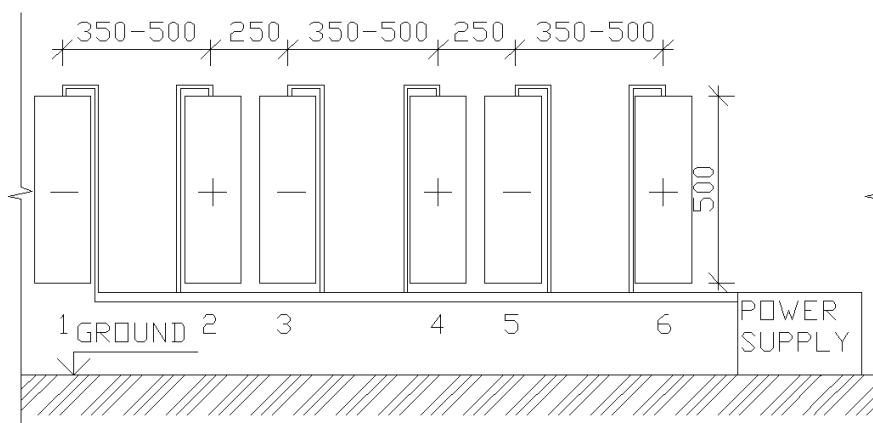

Fig. 69 The view on the electrode units and their recommended placement on the brick wall from the outer wall surface.

- The closer the electrode units are placed the higher current is possible to set up. The distance 350 and 500 mm between electrode units is recommended,

- To spray the distilled water on the brickwork in the case of too high resistance,
- To wrap a part of a wall which is being desalinated (see Fig. 62),
- To keep the clay poultices on the place until the voltage of the power supply gets its maximum,
- The process of desalination should be running until the removed grams of chlorides, nitrates and the sulphates gets steady pattern as clear in the Fig. 70,
- During the tests, it is suitable to take samples which may show the efficiency of the desalination so far.

The following equation expresses the overall charge which passes through the setup of the pilot test at the end of the test.

$$Q = t \cdot I \tag{9.1}$$

where Q.....an overall charge [C]
 I..... the constant current set up for the desalination [A]
 t..... the overall time after the test [s]

- At the end of the desalination treatment, to take the final samples and to compare the concentrations with the concentration at the beginning and with the norm ÖNORM B 3355-1 [21].

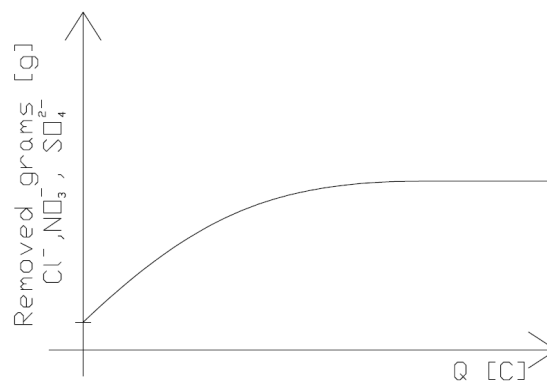

Fig. 70 The supposed pattern of the complete desalination based on a mass removal of salt anions and transferred charge.

9.4.3 The recommended setup for the desalination of the sandstone wall under an applied DC field using the clay poultices

The laboratory experiments were aimed at the desalination of the sandstones under an applied electric field with the use of the clay poultices. From the series of experiments the removed mass and removal rates of chlorides, nitrates and sulphates together with the suitable placement of the electrodes were found out.

The following recommendations are based on the encouraged laboratory results which can be useful for the future desalination of a sandstone wall. The specific conditions such as the initial water contents, initial concentration of salts and the outer temperature have to be taken into account.

The following points describe the way how to set up electrode units for the desalination of a sandstone wall properly in order to get the highest efficiency for desalination:

- The visual survey and the knowledge from the history of the building – to find out the sources of the moisture and the salts,
- To design a solution which avoids moistening of the construction,

Fig. 67 shows the area of a wall which should be desalinated.

- To think about the future placement of the electrode units. The same type of the electrode units as in the experiment 4 are supposed to use for the desalination purpose.
- The supposed placement of the electrode units on the sandstone wall (see Fig. 71, Fig. 72 and Fig. 73).

A.....the recommended distance between the used electrode units (350–500 mm) given from the experimental results,

B..... the height of the used electrode units (500 mm),

C..... the thickness of the sandstone wall (70 mm – a fixed value based on the laboratory experiments),

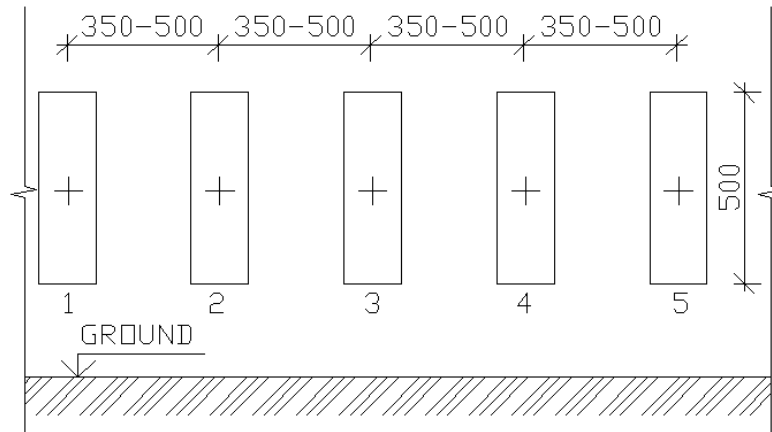

Fig. 71 The front view on the electrode units and their recommended placement on the outer surface of the sandstone wall. The connection to the power supply is not shown.

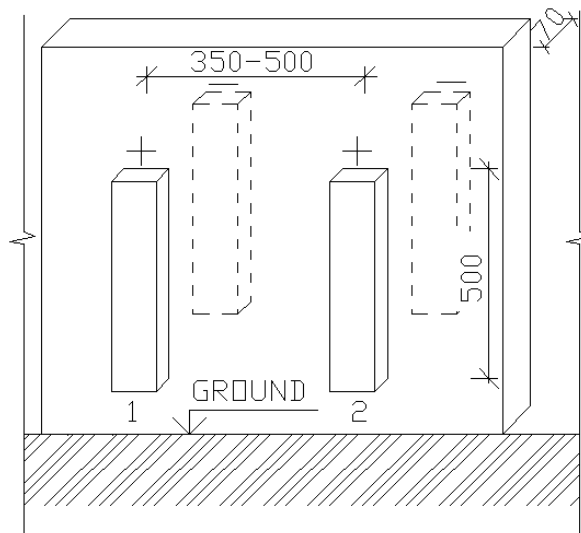

Fig. 72 The scheme of the placement of the electrode units in the axonometric projection on the part of the sandstone wall. The electrode units are placed exactly on the opposite sides and connected to the power supply (not shown). The dashed line – the electrode units on the opposite side (interior).

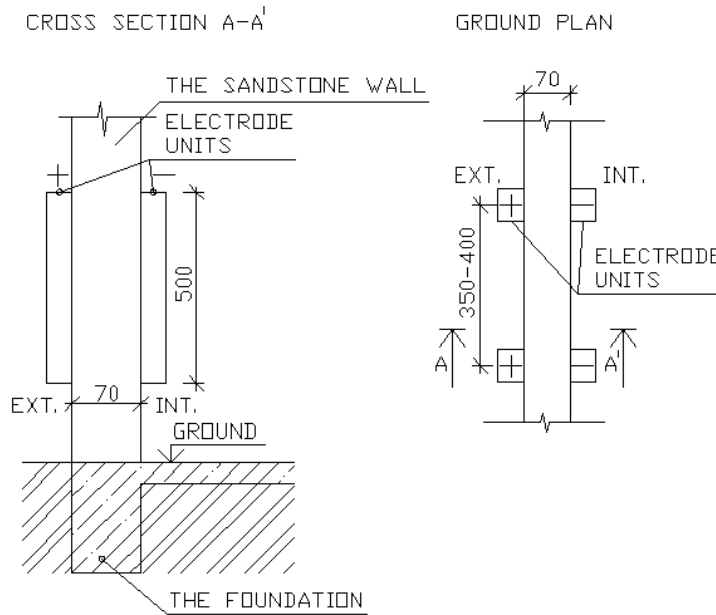

Fig. 73 The scheme of the placement of the electrode units and the distance between them. On the left (the cross section), on the right (the ground plan). EXT. - exterior, INT. - interior;

- To take the initial (reference) samples from the wall between the supposed placement of the electrode units (see Fig. 68).
- To take the reference samples by drilling in the sandstone wall from the different heights and to analyse these samples for the initial water contents and initial salt concentrations. The samples should be taken from the different depth of the wall because the significantly high concentration of the salts may be measured even towards the internal surface of the sandstone wall. This was found in the laboratory experiment 2.
- The finding of the salt concentrations in the whole cross section of the wall may be useful for better placement of the electrode units and thus for the improvement of the efficiency of desalination,
- From the ion chromatography, the initial concentration of chlorides, nitrates and sulphates may be calculated:

The initial concentration of Cl^- [$\text{mg}\cdot\text{kg}^{-1}$]

The initial concentration of NO_3^- [$\text{mg}\cdot\text{kg}^{-1}$]

The initial concentration of SO_4^{2-} [$\text{mg}\cdot\text{kg}^{-1}$]

- To place the electrode units filled with the mixture or brick clay on a sandstone wall and to set up the constant current. The electrode units should be placed on the sandstone wall in the following order (see Fig. 71 to Fig. 73). The closer the electrode units are placed the higher current is supposed to be to set up. The distance 350 and 500 mm between electrode units is recommended,
- To spray the distilled water on the sandstone wall in the case of too high resistance,
- To wrap a part of a wall which is being desalinated (see Fig. 62),
- To keep the clay poultices on the place until the voltage of the power supply gets its maximum,
- The desalination process should be running until the removed grams of chlorides, nitrates and sulphates gets steady pattern as clear in the Fig. 70,
- During the tests, it is suitable to take samples which may show the efficiency of the desalination so far.
- At the end of the desalination treatment, to take the final samples and to compare the concentrations with the concentration at the beginning and with the norm ÖNORM B 3355-1 [21].

9.5 Assumption for the next experimental work based on the results from the dissertation

The future experimental work should be aimed at the extension of the theoretical and the practical knowledge of the processes during the dewatering and the desalination when an electric field is applied. The changes which occur during the electrolysis on the electrodes seem to be limiting factors as for the efficiency of the dewatering due to electro-osmosis as for desalination. The following points might be investigated in the future:

- To analyze the changes at the anode electrode as H_2 is created from the chemical reaction at the anode. The gas might have been taken away directly from the closed laboratory setup. That action might have improved and increased the efficiency of dewatering and desalination.

- The pH influence the dewatering and the desalination significantly therefore it might have been useful to find out and to test the mixtures which can buffer the increases in OH^- ions at the cathode electrode.
- To test the materials which were desalinated by applied electric field for the mechanical properties as the compressive strength, bend strength etc..

ČESKÝ ABSTRACT

Odvlhčování a odsolování stavebních konstrukcí je v současné době velmi diskutované téma. V současnosti jsou používány různé způsoby jak pro odvlhčování tak pro odsolování stavebních konstrukcí. Existující metody jsou účinné, ale je nezbytné vyvíjet stále nové případně starší metody vylepšovat. Problematika vlhkosti ve stavení konstrukci je spojená se solemi, které v ní mohou být rozpuštěny a společně pak v konstrukci dále putovat. Tyto soli pak mohou působit škody v konstrukcích a měnit jak mechanické tak fyzikální vlastnosti stavebních materiálů.

Základní požadavky pro vysoušecí a odsolovací techniky jsou rychlost, účinnost a ekonomický faktor. Presentovaná práce se zabývá odvlhčováním a odsolováním použitím elektrokinetických metod společně s technikou příložených prvků. V první části disertační práce jsou popsány základní teoretické principy v oblasti vlhkosti a solí. V druhé části (experimentální) byly provedeny série měření v laboratoři a v in situ.

V experimentální části disertační práce jsem odvlhčoval a odsoloval cihly, pískovce vlivem účinku elektrického pole. Snažil jsem se optimalizovat laboratorní nastavení, aby odvlhčení a odsolení cihel a pískovců vlivem účinku elektrického pole bylo co největší. Další měření bylo provedeno v in situ, kde byla také použita technika příložených prvků společně s aplikací elektrického pole. V testu bylo dosaženo snížení koncentrace solí. Z experimentálních výsledků je možné dát návod, jak správně postupovat při odsolování.

BIBLIOGRAPHY

- [1] Č. n. i. Praha, ČSN P 73 36 10. Hydroizolace staveb sanace vlhkého zdiva, základní ustanovení., Praha: Český normalizační institut Praha.
- [2] K. Šuhajda, Sanace vlhkého zdiva staveb, Využití tyčové antény při mikrovlnném vysoušení zdiva, PhD thesis, Brno, 2006.
- [3] F. Mrlík, Vlhkostní problémy stavebních materiálů a konstrukcí, Alfa, Bratislava, 1985.
- [4] P. Beneš, Sanace a adaptace budov, Brno: Vysoké učení technické v Brně, fakulta stavební., 2007.
- [5] D. Čuprová, Tepelná technika budov, Brno: Vysoké učení technické v Brně, fakulta stavební, Teoretické základy stavební tepelné techniky.
- [6] A. Sawdy, A. Heritage a L. Pel, „A review of salt transport in porous media, assessment methods and salt reduction treatments,“ in Salt weathering on buildings and stone sculptures, Copenhagen, 2008.
- [7] [Online]. Available: <http://www.centrex.cz>.
- [8] [Online]. Available: www.rea-cz.cz.
- [9] [Online]. Available: www.tzb-info.cz .
- [10] [Online]. Available: www.usporim.cz.
- [11] [Online]. Available: www.odvlhcovani.cz.
- [12] B. Tournier, D. Jeanette a C. Destrigneville, „Stone drying: an approach of effective evaporating surface area, in F Vassina,“ v Proceedings of the 9th International Congress on Deterioration and Conservation of Stone, 1 editor, Amsterdam, The Netherlands: Elsevier Science, 2000.
- [13] J. Bear a Y. Bachmat, Introduction to Modeling of Transport

- Phenomena in Porous Media, Dordrecht: Kluwer Academic Publishers, 1990.
- [14] H. P. Huinink, L. Pel a Michels, „How ions distribute in a drying porous medium: A simple model,“ March 2002.
- [15] E. Ruiz-Agud, F. Mees a P. Jacobs, „The role of saline solution properties on porous limestone salt weathering by magnesium and sodium sulfates,“ Environmental Geology, 2007.
- [16] J. Petkovic, H. P. Huinink, L. Pel, K. Kopinga a v. Hees, „Salt transport in plaster/substrate layers,“ Materials and Structures, pp. 475-490, 2007.
- [17] I. Rörig-Dalgaard, Preservation of murals with electrokinetic - with focus on desalination of single bricks, Lyngby, Denmark: Technical University of Denmark, Department of Civil Engineering, 2008.
- [18] C. W. Correns, „Growth and dissolution of crystal under linear pressure,“ Discussions of the Faraday Society, pp. 267-271, 1949.
- [19] E. M. Winkler a E. J. Wilhelm, „Salt Burst by Hydration Pressures in Architectural Stone in Urban Atmosphere,“ v The Geological Society of America, The Geological Society of America, Inc. Copyright is not claimed on any material prepared by U.S. government employees within the scope of their employment., 1970, pp. 567-572.
- [20] B. A. Lubelli, Sodium chloride damage to porous building materials. Ph.d. thesis, Delft: Technical University Delft, 2006.
- [21] ÖNOR.M.B. 3355-1, Trockenlegung von feuchtem Mauerwerk - Teil 1: Bauwerksdiagnose und Planungsgrundlagen Berlin. ASI Austrian Standards Institute Österreichisches Normungsinstitut (Herausgeber) Deutschland, Bundesrepublik, Beuth Verlag, 2006.
- [22] A. N. Alshawabkeh, A. T. Yeung a M. R. Bricka, „Practical aspects of

- in-situ electrokinetic extraction,“ in Journal Of Environmental Engineering, 1999, pp. 27-35.
- [23] L. M. Ottosen a P. E. Jensen, „Electro-remediation of heavy-metal contaminated soil,“ v Soil and Sediment Remediation: Mechanisms, technologies and applications, 1 editor, IWA Publishing, 2005, pp. 264-288.
- [24] C. D. Ferreira, P. Jensen, L.M. Ottosen and A. Ribeiro, „Preliminary treatment of MSW fly ash as a way of improving,“ Journal of Environmental Science and Health Part A, č. 43, pp. 837-843, 2008.
- [25] A. J. Pedersen, L. M. Ottosen a A. Villumsen, „Electrodialytic removal of heavy metals from different fly ashes. Influence of heavy metal speciation in the ashes,“ Journal of Hazardous Material, pp. 65-78, 2003.
- [26] K. J. Laidler, J. H. Meiser a B. C. Sanctuary, Physical Chemistry, 4 editor, Houghton Mifflin company, 2003, pp. 269-293.
- [27] [Online].Available:
http://web.med.unsw.edu.au/phbsoft/mobility_listings.htm.
- [28] P. W. Atkins, Physical Chemistry, 5. editor, Oxford university press, 1994.
- [29] L. M. Ottosen, I. Rörig-Dalgaard, P. K. Larsen, I. Brajer, P. Bollingstoft, M. Marciniak a M. Svane, Salt Weathering on Buildings and Stone Sculptures, Copenhagen: Technical University of Denmark - Department of Civil Engineering, Brovej, Building 118, 2800 Kgs. Lyngby, Denmark, 2008.
- [30] K. Kamran, Electrokinetic desalination of porous building materials, Eindhoven: Eindhoven University of Technology, PhD thesis, 2012.
- [31] L. M. Ottosen, I. V. Christensen, I. Rörig-Dalgaard, P. E. Jensen a K.

- H. Hansen, „Utilization of electromigration in civil and environmental engineering - Processes, transport rates and matrix changes,“ *Journal of Environmental Science and Health. Part A: Toxic Hazardous Substances and Environmental*, č. 43, 2012.
- [32] M. L. Ottosen a I. Rörig-Dalgård, „Drying brick masonry by electro-osmosis,“ in *Proceedings of the Seventh International Masonry Conference*, London, 2006.
- [33] O. Matyšček, L. Ottosen a I. Rörig-Dalgaard, „Vysoušení cihel pomocí elektrického pole,“ *Stavební obzor*, č. 10, pp. 187-191, červen 2013.
- [34] O. Matyšček, L. Ottosen a I. Rörig-Dalgaard, „Změny pH v cihlách a příložených prvcích využitím elektrického pole,“ *Stavební obzor*, č. 10, pp. 202-204, červenec 2013.
- [35] G. Skibsted, L. M. Ottosen a P. E. Jensen, „The possibility for using electrokinetics for desalination of sandstone with low porosity,“ *8th fib International PhD Symposium in Civil Engineering*, pp. 455-460, 20-23 June 2010.
- [36] L. M. Ottosen a I. V. Christensen, „Electrokinetic desalination of sandstones for NaCl removal - Test of different clay poultices at the electrodes,“ *Electrochimica Acta*, pp. 192-202, 2012.
- [37] M. Castellote, C. Andrade a C. Alonso, „Measurement of the steady and non-steady-state chloride diffusion coefficients in a migration test by means of monitoring the conductivity in the anolyte chamber. Comparison with natural diffusion tests,“ č. 31, pp. 1411-1420, 2000.
- [38] L. M. Ottosen a I. Rörig-Dalgaard, „Desalination of a brick by application of an electric DC field,“ *Materials and Structures*, pp. 961-971, 15 October 2009.

- [39] O. Matyščík, L. Ottosen a I. Rörig-Dalgaard, „Odsolování cihel kontaminovaných v roztoku chloridu sodného účinkem elektrického pole.,“ *Stavební obzor*, č. 11, pp. 38-40, leden 2014.
- [40] O. Matyščík, L. Ottosen a I. Rörig-Dalgaard, „Změny vlhkosti a pH při odsolování cihel účinkem elektrického pole.,“ *Stavební obzor*, č. 11, pp. 15-16, březen 2014.
- [41] L. M. Ottosen, I. V. Christensen, G. Pedersen a J. M. Paz-García, „Development of electrode units for electrokinetic desalination of masonry and pilot scale tests at three locations for removal of chlorides.,“ *Scientific Advances and Innovative. The 9th Symposium on Electrokinetic Remediation*, pp. 129-130, 27-30 June 2010.
- [42] L. M. Ottosen, I. Rörig-Dalgaard a A. Villumsen, „Electrochemical removal of salts from masonry - Experiences from pilot scale,“ *Salt Weathering on Buildings and Stone Sculptures : Proceedings from the international conference*, pp. 341-350, 2008.

PUBLICATION FROM AUTHOR

Matyšček, O., Ottosen L., Rørig-Dalgaard I., Vysoušení cihel pomocí elektrického pole. Stavební obzor, 10, 2013, č. 7, p. 187 - 191. ISSN 1805-2576 (Online)

Matyšček, O., Ottosen L., Rørig-Dalgaard I., Změny pH v cihlách a příložných prvcích využitím elektrického pole. Stavební obzor, 10, 2013, č. 8, p. 202 - 204. ISSN 1805-2576 (Online)

Matyšček, O., Ottosen L., Odsolování cihel kontaminovaných v roztoku chloridu sodného účinkem elektrického pole. Stavební obzor, 11, 2014, č. 1, p. 38 - 40. ISSN 1805-2576 (Online)

Matyšček, O., Ottosen L., Změny vlhkosti a pH při odsolování cihel účinkem elektrického pole. Stavební obzor, 11, 2014, č. 3, p. 15 - 16. ISSN 1805-2576 (Online)

Matyšček, O., Vahalová, E., Nedestruktivní možnosti odsolování a odvlhčování, Brno 2014, sborník z konference Juniorstav 2014. ISBN 978-80-214-4851-3

Vahalová, E., Matyšček, O., Vahala, J., Arnautu, D., Pressure test on treated and untreated Spruce, Brno 2014, sborník z konference Juniorstav 2014. ISBN 978-80-214-4851-3

APPENDICES