

Palacký University in Olomouc

Faculty of Science

Department of Organic Chemistry



Univerzita Palackého
v Olomouci

**Benzo[*d*]thiazole-2-sulfonamides: Their Synthesis and
applications in the field of synthetic method development**

Mgr. František Zálešák

Ph.D. Thesis

Supervisor: doc. RNDr. Jiří Pospíšil, Ph.D.

Academic Year: 2020/2021

Bibliografická identifikace

Jméno a příjmení autora	Mgr. František Zálešák
Název práce	Benzo[<i>d</i>]thiazol-2-sulfonamidy: Syntéza a aplikace ve vývoji syntetických metod
Typ práce	Disertační
Pracoviště	Katedra Organické chemie Přírodovědecká fakulta, Univerzita Palackého v Olomouci
Vedoucí práce	doc. RNDr. Jiří Pospíšil, Ph.D.
Abstrakt	Předkládaná disertační práce je zaměřena na syntézu <i>N</i> -substituovaných a <i>N,N</i> -disubstituovaných benzothiazol (BT) sulfonamidů a jejich aplikaci v kontextu organické syntézy. Vyvinuté přístupy využívají rozdílné strategie, které jsou založeny na vzniku N-S, N-C a C-S vazeb a jsou aplikovány na různé substráty. BT-sulfonamidy jsou pak dále modifikovány pomocí stereoselektivních a chemoselektivních doposud nepopsaných transformací.
Klíčová slova	benzothiazol, sulfonamidy, SuFEx, HBD katalýza, boehmenany, neolignany, syntetické metody, aminokyseliny
Počet stran	161
Počet příloh	9
Jazyk	Anglický

Bibliographical identification

Author's first name and surname	Mgr. František Zálešák
The title	Benzo[<i>d</i>]thiazole-2-sulfonamides: Their Synthesis and applications in the field of synthetic method development
Type of thesis	Doctoral thesis
Department	Department of Organic chemistry Faculty of Science, Palacký University in Olomouc
Supervisor	Assoc. prof. Jiří Pospíšil, Ph.D.
Abstract	Presented Ph.D. thesis focuses on the synthesis of <i>N</i> -substituted and <i>N,N</i> -disubstituted benzothiazole (BT) sulfonamides and their application in the context of organic synthesis. Developed approaches exploit several different strategies based on N-S, N-C and C-S bond formation and they are applied to various substrates. BT-sulfonamides are further used in several modifications, including stereoselective and chemoselective previously undescribed transformations.
Keywords	benzothiazole, sulfonamides, SuFEx, HBD catalysis, boehmenans, neolignans, synthetic methods, aminoacids
Number of pages	161
Number of appendixes	9
Language	English

I hereby declare that I have elaborated this Thesis independently and that I have listed all literature sources and other sources of information that I used. Neither this work nor a substantial part of it has been submitted for another or the same academic degree.

In Olomouc,

František Zálešák

It is my pleasure to thank people who helped me during my PhD study. First, I would like to thank my supervisor doc. RNDr. Jiří Pospíšil, Ph.D. for his advice and continuous support. I would like to thank Prof. Cristina Nevado for the internship opportunity in her research group. Many thanks to RNDr. Adam Přebylka, Ph.D., for HRMS, pK_a measurements and chiral separations. Additionally, I would like to thank all members of our research group, as well as the members of the Department of Organic Chemistry, for creating a friendly and inspiring work environment. Furthermore, every research needs financial support; therefore, I would like to acknowledge IGA_PrF_2021_011 for generous support.

Aim of the thesis

Part I: Benzothiazole – sulfones and sulfonamides

Over the past decade, our research group has been focused on the chemistry of benzothiazole (BT) sulfone and its derivatives. It was observed that benzothiazole and its adjacent sulfone group is responsible for the different chemical behaviour of such substrates, when compared to phenyl sulfones. As an example of this statement, we took an advantage of double activation of methylene group (by BT sulfone and carbonyl) and we use it as a powerful C nucleophile in Mitsunobu alkylation. Such use led to the development of one and two-carbon homologation protocol of alcohols (Scheme 1).¹

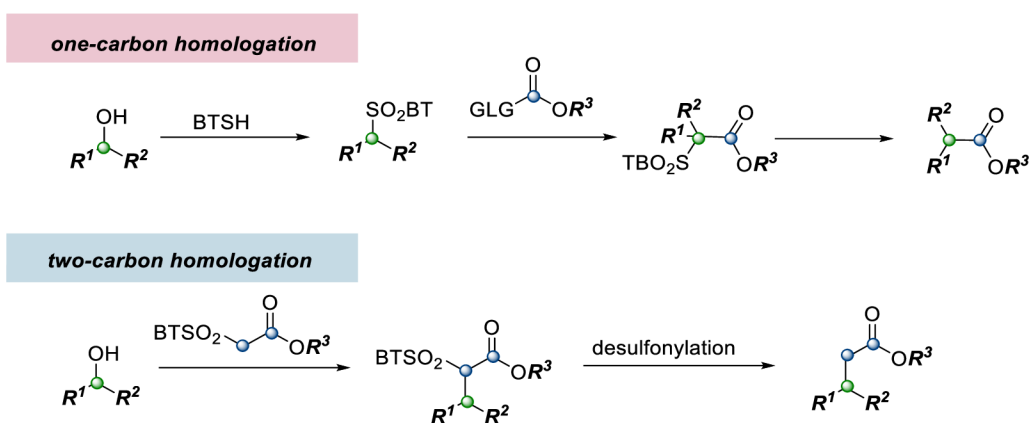

Scheme 1 – Homologation of alcohols

Next, the real power of benzothiazole sulfone derivatives was revealed by the generation of the pluripotent reagent described in a publication of our group,² where Knoevenagel condensation of BT sulfones and aldehydes led to a preparation of trisubstituted highly reactive olefins. Such substrates can be converted into various acyclic, cyclic, or polycyclic scaffolds (Scheme 2).

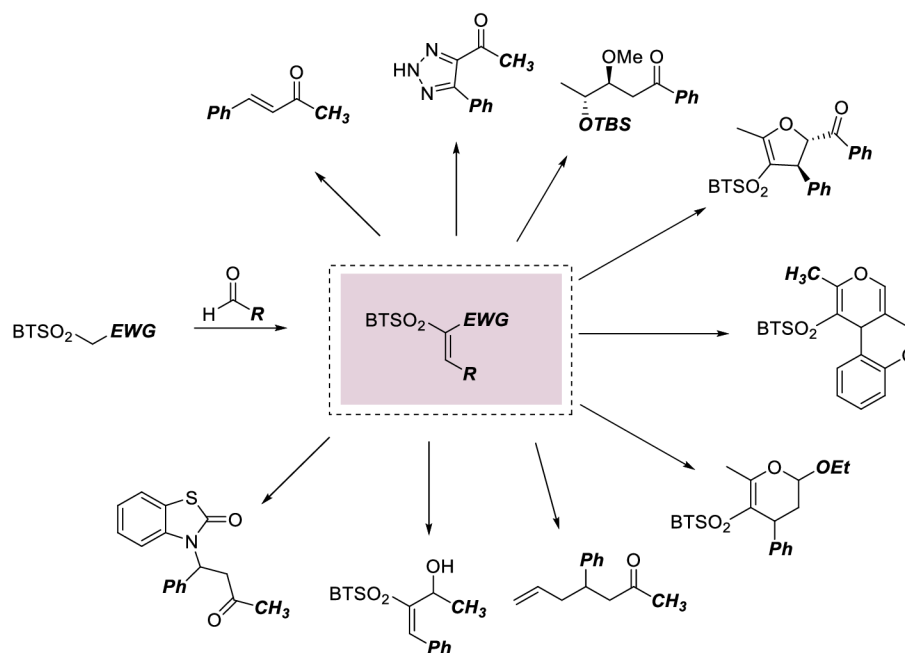

Scheme 2 – Application of BT-olefins in diversity oriented synthesis

Having in hands such achievements, we were obviously curious what would happen if we move into the field of BT-sulfonamides. Unfortunately, the literature search quickly revealed that the synthesis of BT-sulfonamides has been scarcely reported. Therefore, we had to focus on their preparation first. The route towards benzothiazole sulfonamides preparation together with their subsequent modification and their physical-chemical properties is covered in the first part of the thesis (Scheme 3).

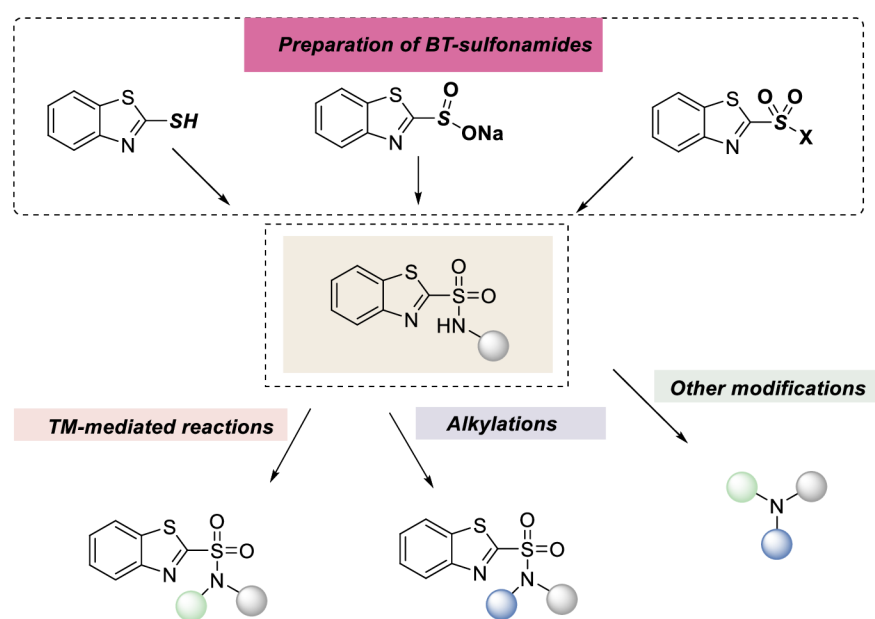

Scheme 3 – General scheme of sulfonamide preparation and their modification

Part II: Plant secondary metabolites (Lignans and neolignans)

Our research group has a long-time interest in a biological activity arising from the field of plant secondary metabolites. In particular, we are interested in the preparation of neolignan derivatives. Our main interest in this field is to prepare and evaluate these compounds against trypanosomes (*Leishmania*) and nematodes (*Caenorhabditis elegans*). The second part of the thesis builds on the previous research activity in the area of phenylpropanoids (dihydrobenzofurans) and covers the pursuit of their preparation I was involved in (Scheme 4).³

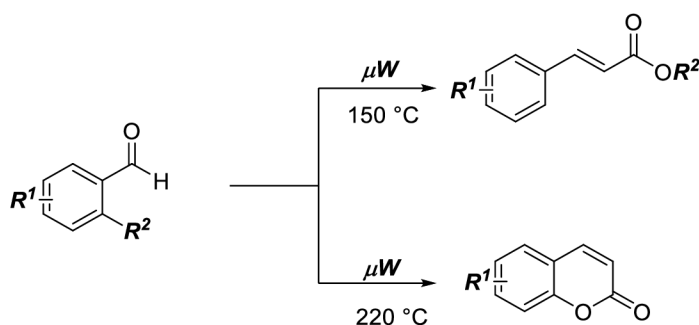

Scheme 4 – Microwave promoted preparation of phenylpropanoids

In particular, the second part of the Thesis describes preparation of neolignan derivatives containing a dihydrobenzofurane core. Our main goal is to develop a general and versatile synthetic route to “non-symmetrical” dihydrobenzofurans (Scheme 5).

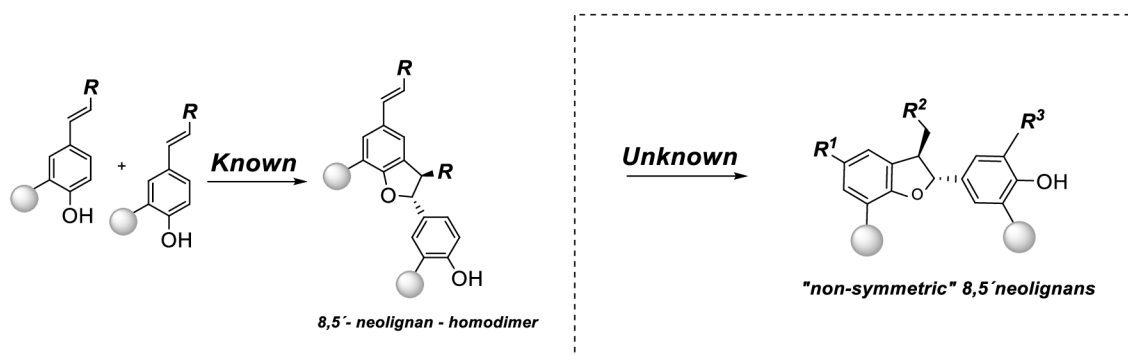

Scheme 5 – General approach towards symmetric and non-symmetric neolignans

Table of contents

Aim of the thesis	6
Table of contents.....	9
List of abbreviation	11
1 Introduction	13
2 Overview of the literature.....	14
2.1 Sulfonamides – biological activity.....	14
2.1.1 History	14
2.1.2 Primary sulfonamides	15
2.1.3 Secondary sulfonamides	15
2.1.4 Tertiary sulfonamides	16
2.2 Sulfonamides - Bioisosters.....	17
2.3 Sulfonamide synthesis.....	18
2.3.1 Synthesis starting from sulfonic acid derivatives – key reagents for Pathway A	18
2.3.2 Sulfonamide synthesis via oxidative coupling (S-N bond formation) – Pathway B.....	25
2.3.3 Sulfonamide synthesis from thiols.....	36
2.4 Sulfonamides in organic synthetic methodology	39
2.4.1 The use of sulfonamides in the transition metal catalysed reactions	40
3 Plant secondary metabolites	41
3.1 Phenylpropanoic compounds - lignans and neolignans	41
3.1.1 Phenylpropanoid biosynthesis	41
3.1.2 Lignans and neolignans	42
3.2 (Dihydro)benzofuran formation (C ₈ , C _{5'}) dimerization - neolignans.....	43
3.2.1 Biomimetic (radical) synthesis of dihydrobenzofurans	44
3.2.2 Synthetic approaches towards substituted (dihydro)benzofurans.....	45
4 Results and discussion.....	52

4.1	Benzothiazolesulfonamides.....	52
4.1.1	Preparation of sulfonamides from sulfonyl halides	52
4.1.2	Oxidative coupling method.....	57
4.1.3	BT-sulfonamide synthesis via S-N coupling followed by oxidation.....	66
4.2	Properties of BT-sulfonamides	72
4.2.1	pK _a of BT sulfonamides.....	72
4.3	Further modification of sulfonamides	73
4.3.1	Alkylation of BT sulfonamides.....	73
4.3.2	Transition metal promoted reactions	77
4.3.3	Smiles rearrangement	88
4.3.4	BT-sulfonamides as <i>N</i> -protecting groups	91
4.4	Use of BT-sulfonamides as H-donors	92
4.4.1	Introduction.....	92
4.4.2	Sulfonamide based HBD catalysts –synthesis and evaluation.....	94
4.5	Boehmenans – Neolignans of benzofurane family	103
4.5.1	Boehmenans – an introduction	103
4.5.2	Biological activity.....	103
4.5.3	Retrosynthesis.....	103
4.5.4	Homocoupling approach.....	104
4.5.5	Cross dehydrogenative coupling (CDC).....	105
5	Summary and perspective.....	108
6	Literature	110
7	Experimental part	128

List of abbreviation

AIDS	Acquired immunodeficiency syndrome
ATP	Adenosine triphosphate
BA	Bronsted acid
BHT	Dibutylhydroxytoluene
BT	Benzothiazole
BTMG	2- <i>tert</i> -Butyl-1,1,3,3-tetramethylguanidine
BTSH	2-Mercaptobenzothiazole
CDC	Cross-dehydrogenative coupling
COX-2	Cyclooxygenase-2
DABCO	1,4-Diazabicyclo[2.2.2]octane
DABSO	1,4-Diazabicyclo[2.2.2]octane bis(sulfur dioxide) adduct
DBU	1,8-Diazabicyclo(5.4.0)undec-7-en
DCDMH	1,3-Dichlor-5,5-dimethyl-hydantoin
DCE	1,2-Dichlorethan
DCG	Dehydrodiconiferyl alcohol glucoside
DCM	Dichloromethane
DFT	Density-functional theory
DHPS	Deoxyhypusine Synthase (enzyme)
DHP	3,4-Dihydropyran
DEAD	Diethyl azodicarboxylate
DIAD	Diisopropyl azodicarboxylate
DIPEA	<i>N,N</i> -diisopropylethylamine
DMAP	4-Dimethylaminopyridine
DMF	<i>N,N</i> -Dimethylformamide
DMSO	Dimethylsulfoxide
dr	Diastereomeric ratio
EGFR	Epidermal growth factor receptor
ETH	Eidgenössische Technische Hochschule
EWG	Electron-Withdrawing Group

er	Enantiomeric ratio
FDA	U.S. Food and Drug Administration
FMA	Fukuyama-Mitsunobu alkylation
HBD	Hydrogen bond donor
HIV	Human Immunodeficiency Virus
HPLC	High-performance liquid chromatography
HRP	Horseradish peroxidase
KHMDS	Potassium bis(trimethylsilyl)amide
LUMO	Lowest Unoccupied Molecular Orbital
<i>m</i>CPBA	<i>meta</i> -chloroperoxybenzoic acid
NBS	<i>N</i> -Bromosuccinimide
NCS	<i>N</i> -Chlorosuccinimide
NIS	<i>N</i> -Iodosuccinimide
NMR	Nuclear magnetic resonance spectroscopy
PBS	Phosphate-buffered saline
SMD	Solvatation model based on density
SuFEx	Sulfur-Fluoride exchange
TBAI	Tetra- <i>N</i> -butylammonium iodide
TBAB	Tetra- <i>N</i> -butylammonium iodide
TBHP	Tert-Butyl hydroperoxide
TEA	Triethylamine
THF	Tetrahydrofuran
THP	Tetrahydropyran
TMEDA	Tetramethylethylenediamine
TEMPO	2,2,6,6-(Tetramethylpiperidin-1-yl)oxyl

1 Introduction

The organic synthesis has a tremendous impact on the human life and therefore it plays an important role in a human history. The origins of organic synthesis of naturally occurring substances as we know today, dates back to 19th century. However, it was not until 1950s when the development of more powerful spectroscopic method allows to determine and to characterize chemical structures present in nature. Until that time, the synthesis of natural products was together with degradative investigations, the main method of structure determination. For some, this was the turning point where the organic synthesis lost its justification.^{4,5}

However, there were others, who realized the great opportunity for tackling new synthetic challenges and “free themselves” from restrictions and familiar reactions of structural degradation. This was the start of the golden era of organic synthesis and many famous and important chemical transformations were developed *en route* to complex natural products. The names like Overman, Corey, Stork layed a groundwork of organic chemistry as we know today.^{6,7} One of the biggest accomplishments achieved in those days was the synthesis of B₁₂ (Woodward – Harvard, Eschenmosher – ETH). This achievement was not only the synthesis complex B₁₂ structure, but also the discovery of so-called Woodward-Hoffmann rules that boosted the orbital-based theoretical approach in organic chemistry.^{8,5} The highest peak of that era is considered the synthesis of Palytoxin, described as “the Mount Everest of organic synthesis” (Kishi).⁹

Since that time, the organic synthesis went through a long journey, and now we do consider the field of novel transformation development and the field of natural product synthesis as two distinct fields. The main goal of modern methodology development area is not only to describe a new reactions but also to come with a convenient, broadly applicable method with reasonable atom, step and redox economy.¹⁰⁻¹²

The aim of this Thesis is to guide the reader through the endeavor to solve a long-standing problem in the chemistry of heterocyclic sulfonamide preparations. Sulfonamides, where the “traditional” synthetic methods fail to deliver the targeted structures in good yields. The goal was to investigate their synthesis and to describe and understand their unique position among other sulfonamidic derivatives.

2 Overview of the literature

The first part of this chapter focuses on the brief introduction into the biological activities of compounds with sulfonamide functionalities. It also describes the unique position of sulfonamides among pharmaceuticals. Next, the comprehensive summary of the synthetic routes towards sulfonamides and methods of their preparation is described. The second part is introducing phenylpropanoid structural pattern (plant secondary metabolites) together with biomimetic and synthetic approaches toward (dihydro)benzofuran skeleton.

2.1 Sulfonamides – biological activity

The following text covers biological activity of representative examples of structures with sulfonamide moiety. Many of these compounds have been on a pharmaceutical market for several years and their position is irreplaceable (>100 FDA-approved compounds). Their biological activity area is large and ranges from antibiotic and diuretic properties to antiviral and anti-retroviral.¹³

2.1.1 History

The first mention about sulfonamides among synthetic drugs dates back to 1930s, when German scientists described anti-microbial properties of compound named Prontosil **2-1**. First, the scientists attributed these properties to azo functionality that Prontosil **2-2** also contains, however, later it was found, that this compound is only a pro-drug. The active compounds is released only after the reduction of azo to amino group in human body (Figure 1). Such discovery was a huge breakthrough in medicine, because there was still lack of antimicrobial drugs that could be safely used in human bodies and it has started the modern era of chemotherapeutics. How important this discovery was, is best represented by the Nobel prize which was awarded to Gerhard Domagk “for the discovery of the antibacterial effects of Prontosil” in 1939.¹⁴

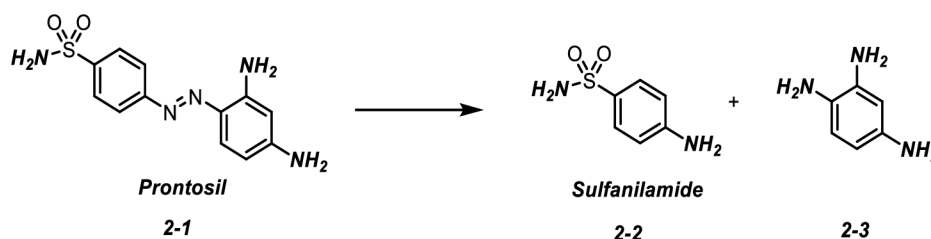

Figure 1– Metabolism of Prontosil in a human body

Since then, many more potent and even safer alternatives to “sulfa drug” (common name of Prontosil) have been synthesized. Their anti-microbial properties are the results of

inhibition of dihydropteroate synthase (DHPS), that catalyses the conversion of *para*-amino benzoate to dihydropteroate.¹⁵ This key step in folate synthesis prevents cells from dividing. However, the sulfonamide derivatives do not possess only antimicrobial properties. Their additional biological activities together with examples will be briefly discussed in the following subchapters that are organised according to their substitution patterns.

2.1.2 Primary sulfonamides

Celecoxib **2-5**, as an example of primary sulfonamide, is a nonsteroidal anti-inflammatory drug (COX-2 inhibitor), and it is used for the treatment of rheumatoid arthritis and acute pain.¹⁶ It could also be used to decrease a risk of colorectal adenomas.¹⁷ Moreover, in recent years some evidences have been linking Celecoxib **2-5** with the possible treatment of mental health disorders such as depression, bipolar disorder and schizophrenia.^{18,19} Furosemide (Laxis®) **2-4** is another primary sulfonamide used in a treatment of edema. It is usually the first-choice chemotherapeutics to treat edema caused by congestive heart failure. Like other loop diuretics, it inhibits Na-K-Cl cotransporters in the thin ascending limb of the loop of Henle, where it binds to the chloride transport channel (Figure 2).²⁰

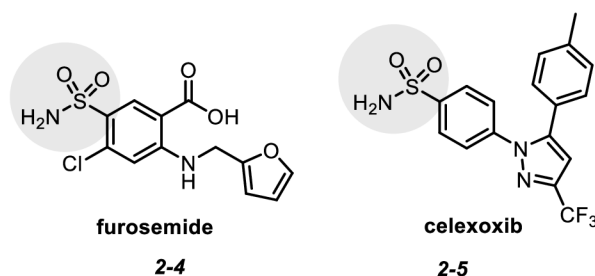

Figure 2 - Examples of compounds with primary sulfonamidic group

2.1.3 Secondary sulfonamides

Sulfomethaxole **2-7** is a very important drug used to treat urinary tract infections. It shows synergistic effect with Trimethoprim also known as co-trimoxazole (In a ratio of 20:1, Sulfomethaxole:Trimethoprim). It is used for both, treatment and prevention of pneumocystis pneumonia or toxoplasmosis. Its mode of action is like other sulfonamide antibiotics that is the inhibition of dihydropteroate synthase (DHPS). One of the biggest drawbacks of using sulfonamidic antibiotics is a possible risk of body response called sulfa allergy (symptoms - skin rash, itchy eyes etc.) that could lead to serious complications.²¹

Sulfasalazine **2-7** as another example of primary sulfonamides is used to treat ulcerative colitis²² and Crohn's disease.²³ After uptake, sulfasalazine **2-7** is metabolized in colon by bacteria (the azo group is reduced to free amino group) and generated amine is the actual active substance.²⁴ Additionally, sulfonamidic compounds have also anti-diabetic properties (Carbutamide **2-8** and Glibencamide **2-9**). Glibencamide is a type 2 diabetes drug that acts as inhibitor of the ATP-sensitive potassium channels in pancreatic beta cells (Figure 3).²⁵

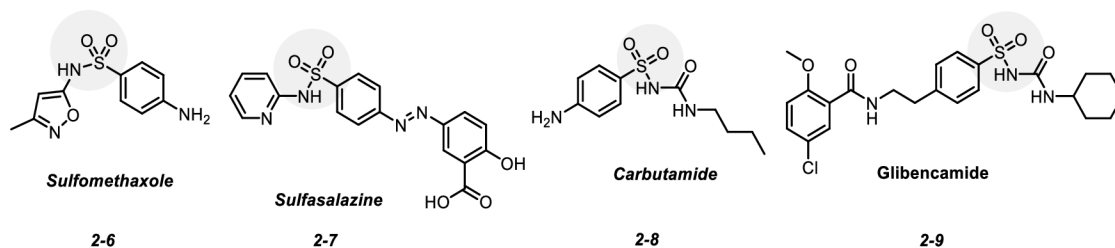

Figure 3- Examples of compounds with secondary sulfonamidic group

2.1.4 Tertiary sulfonamides

An example of the tertiary sulfonamide is a compound called Darunavir **2-10**. It is an anti-retroviral compound that is used to treat HIV/AIDS. The mechanism of action is based on the inhibition of HIV-1 protease (FDA 2006).²⁶ Probenecid **2-11**, *N,N*-dipropyl sulfonamide, was primarily developed for a treatment of gout and hyperuricemia. In addition, it is sometimes used in a combination with other antibiotics to prolong the effect of those, and to protect the kidneys.²⁷ Unfortunately, it is sometimes misused by athletes as a masking agent to prohibited substances during anti-doping tests (Figure 4).²⁸

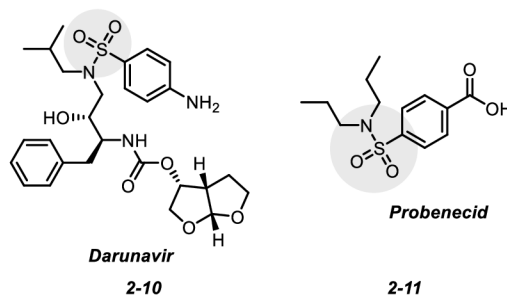

Figure 4 - Examples of compounds with tertiary sulfonamidic group

2.2 Sulfonamides - Bioisosters

Sulfonamide moiety was identified as one of the first bioisoster of the carboxylic acid functionality. Even though, the acidity of sulfonamide group is in general several orders of magnitude lower ($pK_a = 10$ vs $pK_a = 6.5$), the sulfonamide group can adopt similar orientation towards hydrogen bond donor, when compared to carboxylate. Such behaviour is attributed to the same distance between two oxygens of the sulfonyl moiety when compared to the distance between oxygens of carboxylic group.²⁹ When EWG group onto sulfonamidic nitrogen is added (e.g. carbonyl), the acidity of *N-H* proton rises considerably (from $pK_a = 10$ to 4.5). The pK_a value, which is now in the same range as carboxylic acids can lead to an improvement in pharmacological properties in comparison to carboxylic functionalities, as was reported on occasion.^{30,31} Recently, Kim et al. described bioisosteric properties of methylsulfonamidic group **2-12** to methoxy **2-13** that resulted into better solubility and even improved inhibition of human cancer cell growth (Figure 5).³²

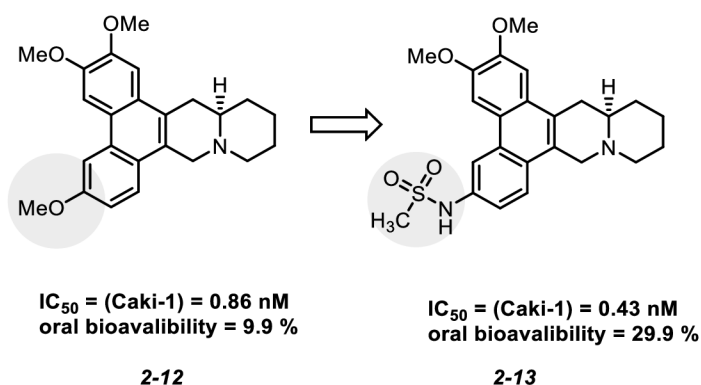

Figure 5 - Sulfonamides as bioisosters

2.3 Sulfonamide synthesis

There are three general retrosynthetic approaches towards sulfonamide moiety. The first two are based on the oxidation of sulfur from its lower oxidation state prior to formation S-N bond (Figure 6). The most classical approach is based on the halide substitution and explores readily available synthesis of starting materials (Figure 6, **Pathway A**). Although, this approach is well established, it struggles in combination with more complex molecules due to the poor functional group tolerance. Still, it remains as the choice number one, when the retrosynthetic analysis of sulfonamides is considered. The problems with incompatibility of this approach in case of oxidation of sulfide moiety were partially overcome by the oxidative coupling approach (Figure 6, **Pathway B**). This approach usually starts with “sulfur” in oxidation state +IV. Finally, as mentioned earlier, the opposite approach could be also applied (Figure 6, **Pathway C**). In this case, a sulfur-nitrogen bond is formed and after that, the generated sulfenamide is oxidized to corresponding sulfonamide. It is fair to say that this approach is underdeveloped and there are only limited procedures describing this transformation.

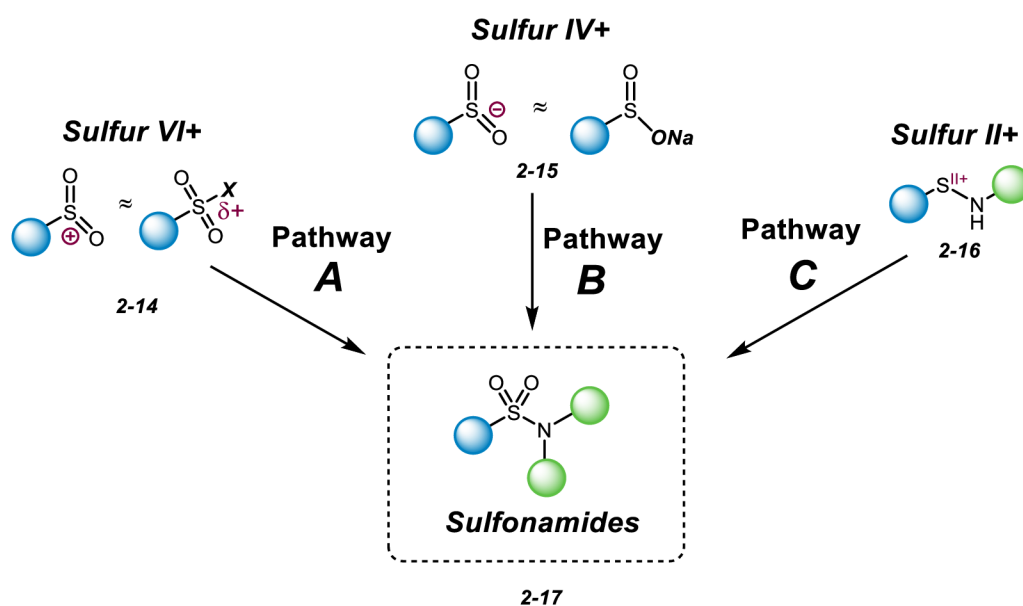

Figure 6 – Retrosynthetic approaches towards sulfonamides

2.3.1 Synthesis starting from sulfonic acid derivatives – key reagents for Pathway A

In this chapter, general methods towards the sulfonamide **2-17** synthesis starting from sulfonic acid halides **2-14** are discussed. Despite several limitations, this approach is used as the golden standard for the preparation of sulfonamides. The reaction of amine and sulfonyl halide **2-14** under basic conditions is the “classic” approach, familiar from the introductory organic chemistry courses (Figure 7).

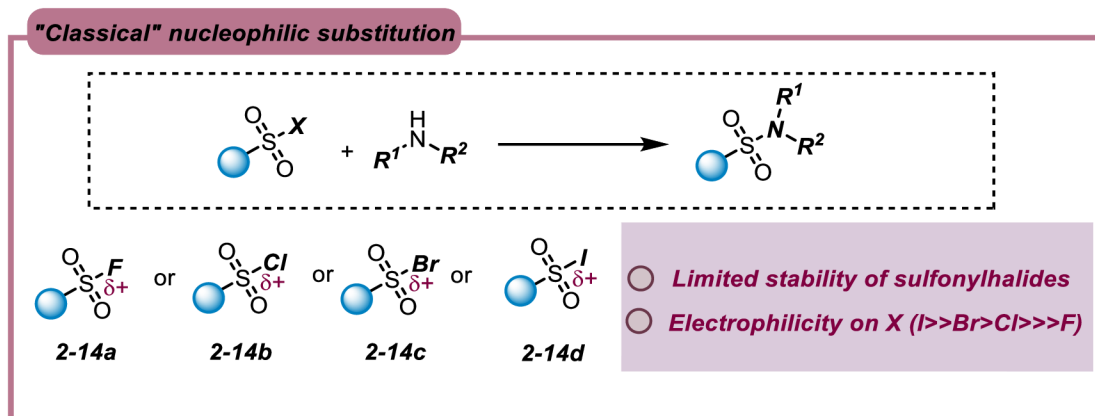

Figure 7 – Sulfonylhalides as the main precursors

In general, sulfonyl chlorides **2-14b** are used as the starting material due to their simple preparation and good balance between stability and reactivity. Sulfonyl fluorides **2-14a** are less reactive and more stable than the corresponding chlorides **2-14b**. On the other hand, sulfonyl bromides **2-14c** and iodides **2-14d** lack thermal stability and they are highly reactive. From that reasons, they are usually generated in situ and trapped by amine immediately after their generation. For clarity such methods (in situ generation of sulfonyl bromides and iodides) are discussed in the chapter **2.3.2 - Sulfonamide synthesis via oxidative coupling (S-N bond formation) – Pathway B**.

If we omit several limitations linked to the functional group tolerance, the main drawback of the sulfonyl halide-based approach is the presence of relative electrophilic halide atom connected to sulfonyl moiety. The electrophilicity of the atom can be of such magnitude, that the sulfonyl halide can serve as halogenation reagent. Thus, the reaction can lead to fairly different products than towards desired sulfonamides. To better demonstration of the halogen-tied electrophilicity, LUMO maps of all four possible benzenesulfonyl halides are shown in Figure 8. The absolute energy values (e/au^3) are used for the quantification of the electrophilic areas (Å^2) present on halogen atom. The increasing electrostatic potential values together with the increasing areas nicely represent the electrophilic properties. The electrostatic potential value and the most electrophilic area increases from benzenesulfonyl fluoride (**A**) towards benzenesulfonyl chloride (**B**), bromide (**C**) and iodide (**D**), respectively (Figure 8). The LUMO map surfaces and energy values were obtained from Spartan Molecular Database (SMD – calculated for equilibrium geometry; DFT ω B97X-D, 6-31G*).

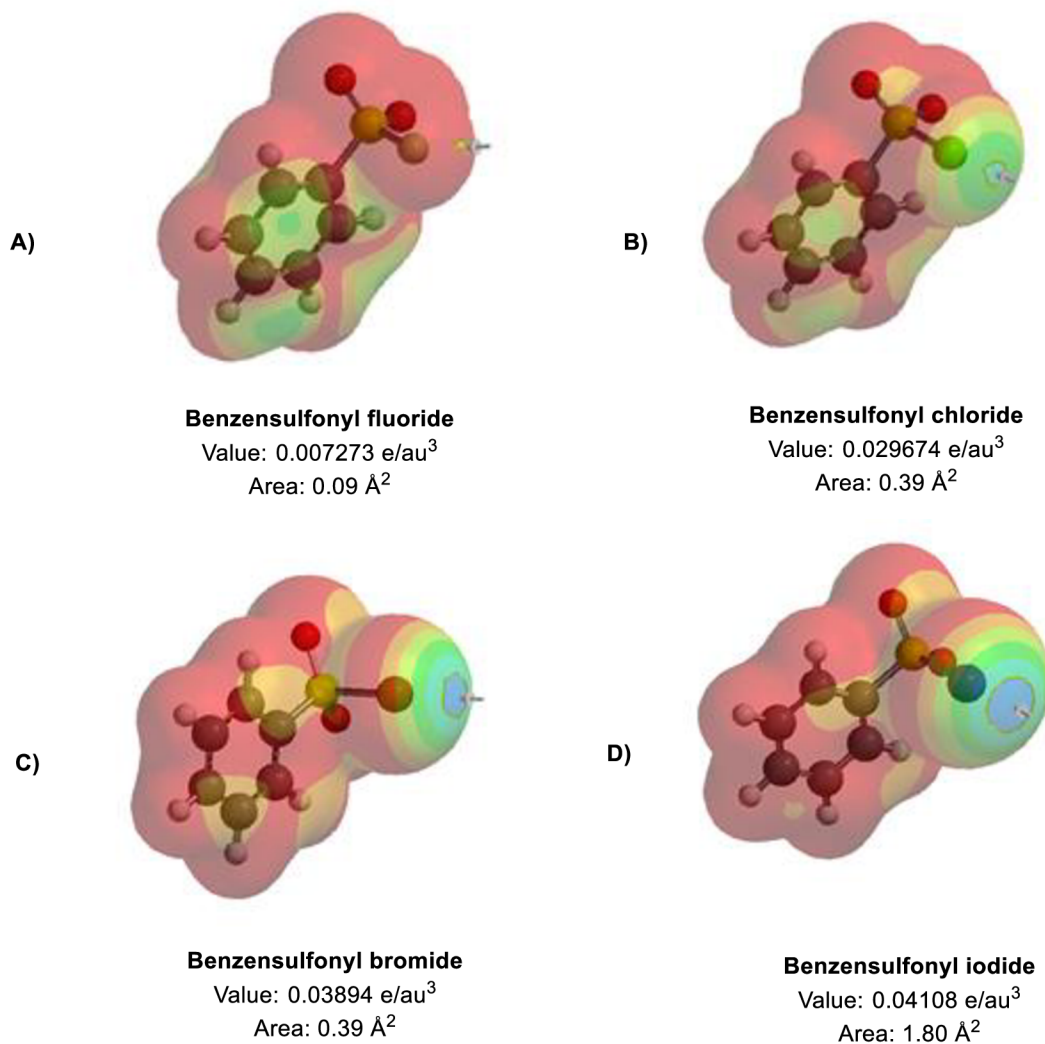

Figure 8 – LUMO maps of benzensulfonyl halides

2.3.1.1 Preparation of sulfonamides from sulfonyl fluorides

Sulfonyl fluorides **2-14a** are stable equivalents of the corresponding sulfonyl chlorides **2-14b**. Their reactivity substantially differs, since in the most cases they are not hydrolyzed in water. This advantage of such behaviour was taken by Sharpless et al. and used in so-called SuFEx method.³³ As the main advantage, sulfonyl fluorides **2-14a** barely undergoes undesired competitive nucleophilic attack towards fluorine atom of the homolytic S-F cleavage.³⁴ As mentioned previously, sulfonyl fluorides **2-14a** are also much stable towards hydrolysis, due to the thermodynamic stability of S-F bond, in comparison to S-Cl bond (ca 40 kcal . mol⁻¹).³⁵ What makes SuFEx approach unique is the special fluoride-proton interaction. The strong interaction of F⁻ with H⁺ or R₃Si⁺

makes this process controllable and brings various possibilities how to suppress undesired reaction pathways.³⁶

The sulfonyl fluoride **2-14a** synthesis then can be achieved from various synthons in different oxidation states of sulfur (S^{VI} , S^{IV} or S^{II}). In the Scheme 6, several synthetic approaches towards sulfonyl fluorides **2-14a** are covered. Namely from sulfonic acids **2-22**,^{37,38} hydrazides **2-18**,³⁹ sulfinic acid salts **2-15**,⁴⁰ arylhalides **2-19**,^{41,42} heteroaryl thiols **2-20**,⁴³ disulfides **2-21**⁴⁴ and sulfonylchlorides **2-14b** (Scheme 6).⁴⁵⁻⁴⁷

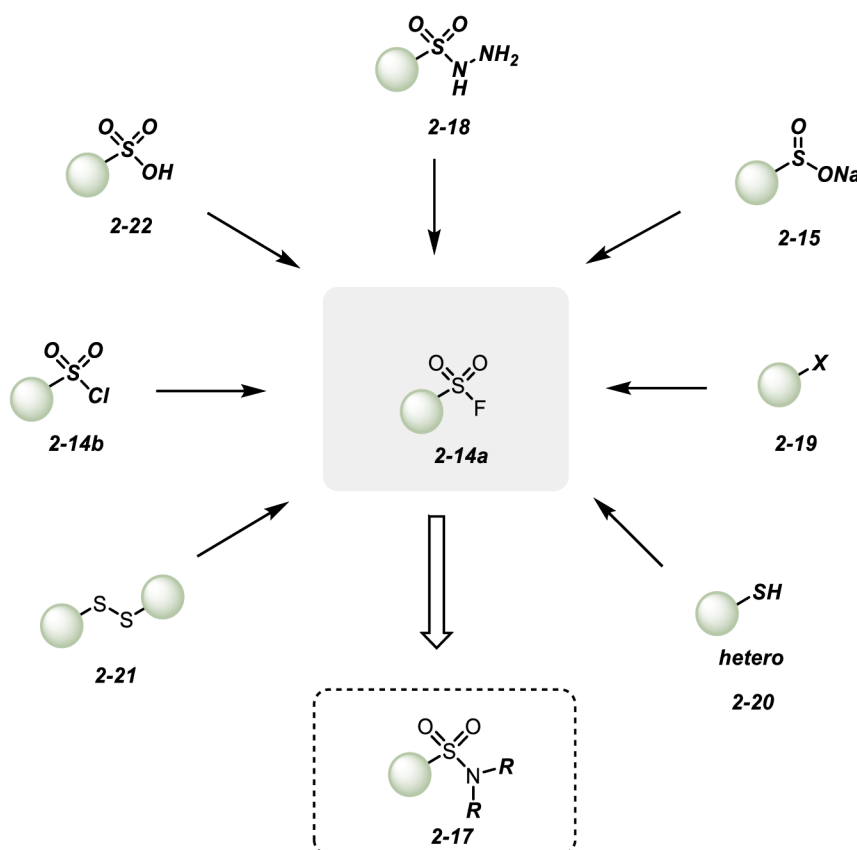

Scheme 6 – Possible approaches towards sulfonyl fluorides

Once sulfonyl fluoride **2-14a** is prepared, the synthesis of sulfonamide **2-17** proceeds upon the addition of amines in the presence of base (DIPEA, TEA, DMAP or pyridine). The choice of solvent is virtually limitless and ranges from DCM, DMSO and MeCN to alcohols (*t*BuOH, MeOH) and even water. Since the experimental procedures vary only little from substrate to substrate, only a representative protocol readily applicable on most of the substrates are shown within this chapter. For example, the combination of DMAP

and pyridine is used when various sulfonamides **2-25** are targeted as products (Scheme 7).⁴⁸

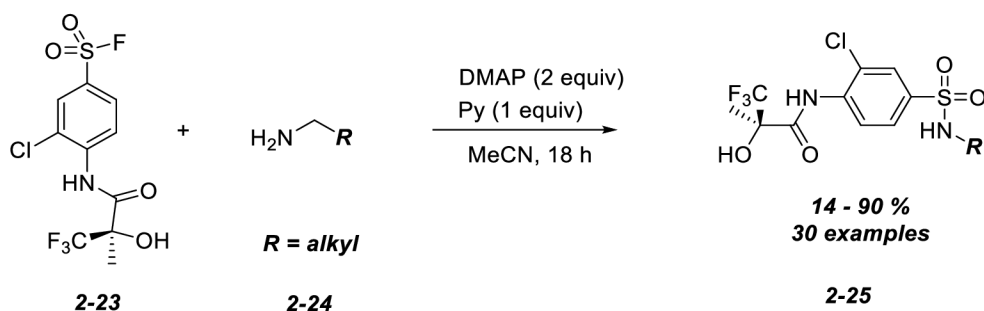

Scheme 7 – Most common sulfonamide synthesis protocol based on fluorine- nitrogen exchange

If the starting sulfonyl fluoride **2-26** is activated for nucleophilic substitution (e.g. EWG, F in α position to sulfone) the reaction proceeds even without the additional activation (Scheme 8).⁴⁹

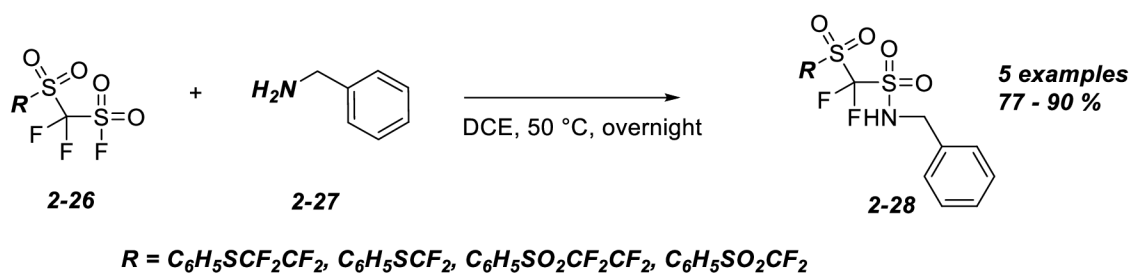

Scheme 8 – Example of fluorine- nitrogen exchange vol.2

D. Ball et al. reported interesting solution for less reactive sulfonyl fluorides **2-29** where temperatures exceeding 100 °C are needed. In this case, the addition of Lewis acid activates the sulfonyl group (coordination to sulfonyl oxygens) and at the same time activate the leaving group by the coordination to fluorine atom. After the screening of several Lewis acids, bidentate $\text{Ca}(\text{NTf})_2$ provided the desired sulfonamides **2-30** in best yields. In addition, if the solvent can stabilize the leaving group by hydrogen bonding, the synergistic effect with $\text{Ca}(\text{NTf})_2$ was observed (Scheme 9).⁵⁰

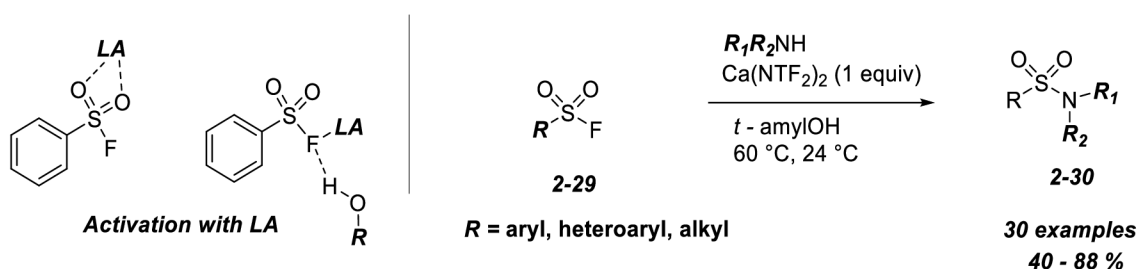

Scheme 9 – The use of $\text{Ca}(\text{NTf})_2$ as an activator in sulfonamides synthesis

The real power of SuFEx chemistry is its applicability in the context of so-called “Click chemistry”. The chemistry that requires high-yielding, chemoselective, simple, efficient, and water-tolerant transformations. A wide range of chemoselective attachments of probes to the substrate of interest (chemistry of bioconjugates) is the key weapon in the biological process monitoring and in the determination of mechanisms of actions. For example see synthesis of calixarene-based glycocluster (Scheme 10).⁵¹

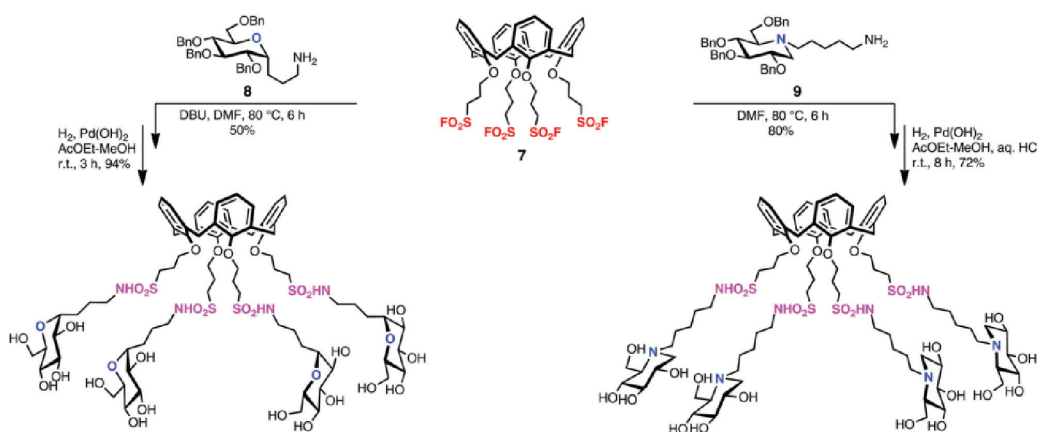

Scheme 10 – SuFEx protocol in context of calixarene chemistry (The Scheme was adopted from <https://pubs.rsc.org/en/content/articlepdf/2017/ob/c6ob02458k>)

2.3.1.2 Preparation of sulfonamides from sulfonyl chlorides

The traditional protocols use sulfonyl chlorides **2-14b** as the main synthons that are easily accessible by various methods. Sulfonyl chlorides **2-14b** are in general obtained by chlorosulfonation of aromatic compounds and heterocycles,^{52,53} a sulfochlorination of aliphatic hydrocarbons,⁵⁴ or by oxidation of thiols⁵⁵ to sulfonic acids that are converted to sulfonyl chlorides (Figure 9).⁵⁶ As a drawback, all those methods proceed under harsh conditions, in general. This fact disqualifies such procedures from late-stage functionalization steps.

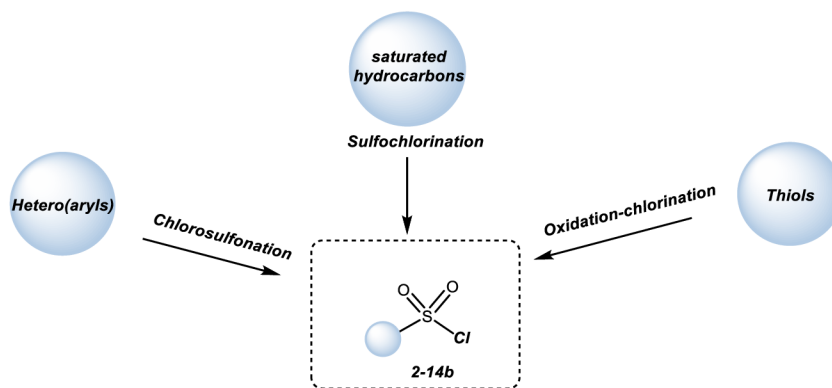

Figure 9 – Key retrosynthetic steps

The sulfonyl chlorides **2-14b** then can be readily converted to sulfonamides **2-17** in the presence of an excess of the amine (Figure 10).^{57–64} The major limitation of this approach is the thermal instability of generated sulfonyl chlorides **2-14b** that is especially apparent in the case of sulfonyl chlorides **2-14b** substituted with heterocycles. Majority of conditions used for sulfonyl chloride **2-14b** to sulfonamide **2-17** conversion, are the same as those used for sulfonyl fluorides **2-14a**. However, due to greater reactivity towards nucleophilic attack on sulfur centre, milder conditions are usually required.

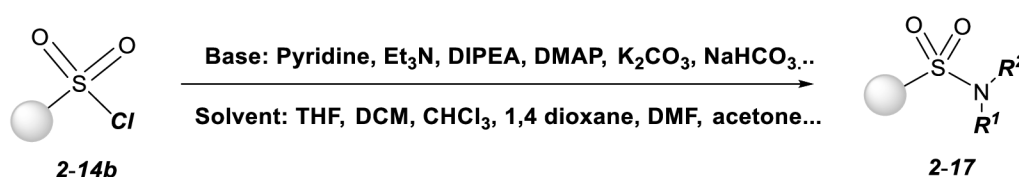
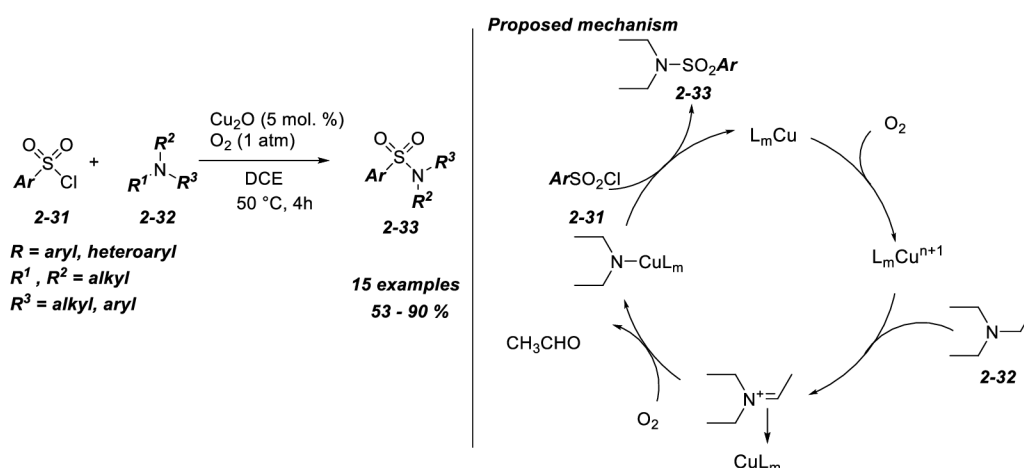

Figure 10 - Typical conditions used for sulfonamide synthesis

If basic conditions are a problem (substrate/functional group tolerance), then sulfonyl chlorides **2-31** can be transformed to sulfonamides **2-33** in the means of copper catalyzed oxidative C-N bond cleavage/S-N bond formation protocol. In this case, tertiary amines **2-32** undergo a reaction with sulfonyl chlorides **2-31** in the presence of Cu^{II} and O_2 to the desired sulfonamides **2-33** in good to excellent yields. The plausible mechanism proceeds via iminium ion that is generated from amine by high-valent copper. After the elimination of aldehyde, amine **2-32** reacts with sulfonyl chloride **2-31** and provides sulfonamide **2-33** (Scheme 11).⁶⁵



Scheme 11 – Cu^{II} promoted oxidative coupling of RSO_2Cl

Interestingly, when cyclic amines **2-35a**, **2-35b** were reacted under the same reaction conditions, the product of ring opening and a chlorination was observed (Scheme 12).

Such result is therefore not compatible with the reaction mechanism shown in Scheme 11 and more likely suggests the radical mechanistic pathway. On the other hand, the addition of radical scavengers do not spoil the reaction outcome and the mechanism remains unclear.⁶⁵

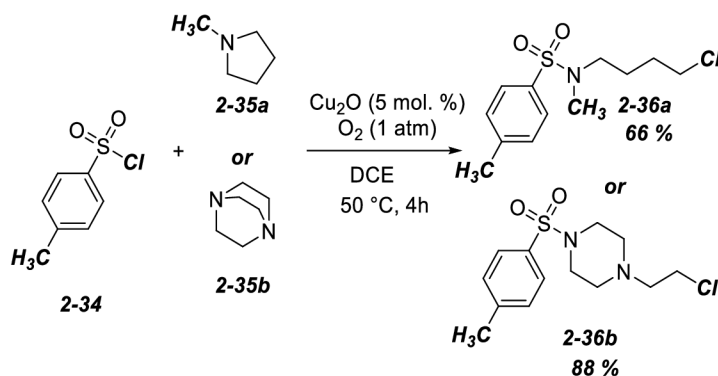

Scheme 12 – Cu^{I} -promoted oxidative coupling of cyclic tertiary amines

2.3.2 Sulfonamide synthesis via oxidative coupling (S-N bond formation) – Pathway B

In recent years, oxidative coupling processes proved to be a powerful synthetic method. However, the focus was in general aimed on the *carbon-carbon* bond and *carbon-heteroatom bond* (O, S, N, P) formation. Overwhelming potential of sulfonamides and their derivatives as promising biologically active compounds increased the requirement of novel synthetic routes towards *sulfur-nitrogen* bond formation. Recently developed oxidative coupling methods usually use combinations of dihalogen (I_2 , Br_2 or their sources) and oxidizing agents (peroxides or oxygen). This protocol generates in situ sulfonyl halide that is immediately trapped by amine (Figure 11).

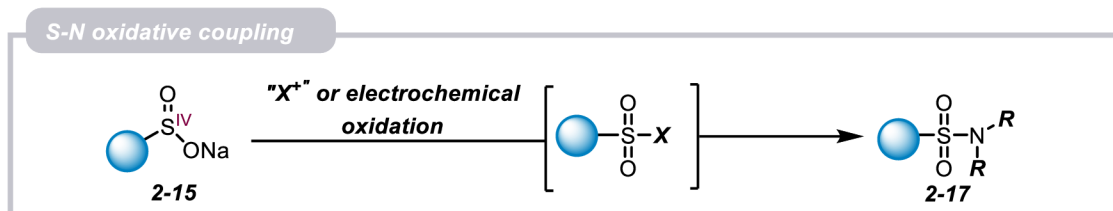
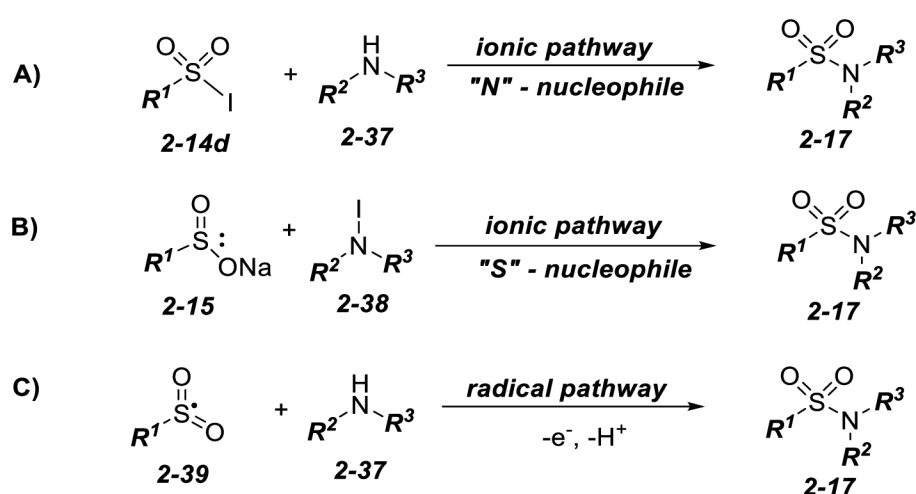

Figure 11 - S-N oxidative coupling based on the use of RSO_2Na

2.3.2.1 Synthesis of sulfonamides from sulfinic acid salts

The preparation of sulfonamides via oxidative coupling starts from sodium sulfinates, readily available sulfur-base derivative. Their synthesis proceeds under mild and air

stable conditions and these compounds possess great thermal stability. The common feature of all described methods is the in situ generation of sulfonyl halides that are subsequently converted into sulfonamides. Dihalogens (mostly I₂ or Br₂) are responsible for the oxidation step. The oxidizing agent can be also used in combination with an external oxidant that allows the use of dihalogen (or equivalent) in substoichiometric amounts. There are two main mechanisms that could be applied during the targeted transformation. The ionic mechanisms that is exploring the electrophilic nature of sulfur in sulfonyl halide (**A**) or *N*-haloamine (**B**). The radical pathway (**C**) then refers to the homolytic cleavage of labile sulfur-halogen bond (Scheme 13).⁶⁶



Scheme 13 – Three ways how sulfonamides can be prepared from sulfinic salts

Oxidative coupling where sulfur(+IV) is oxidized to sulfur(+VI) was investigated by Zhao et al.⁶⁷ In this approach, sulfinate salt **2-40** was oxidized by I₂, that was generated from TBAI in the presence of TBHP (Scheme 14). The authors observed that electronic effect on the sulfinic salt **2-40** has a significant impact on the yield of the reaction. When a salt bearing a substituent with M⁺ effect on the aromatic ring was used, yields were nearly quantitative. However, when salts **2-40** with electron withdrawing substituents were used (R¹ = ArCF₃) the yield decreased considerably (Scheme 14).

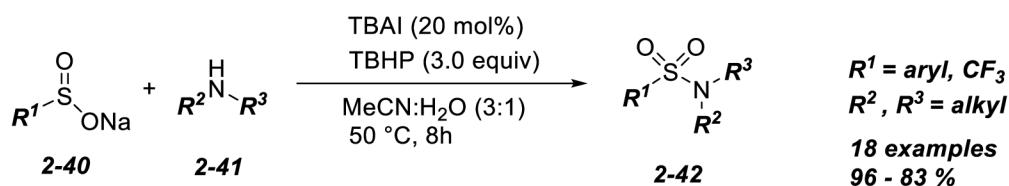

Scheme 14 – Sulfonamide synthesis based on S(+IV) oxidation

The combination of sodium percarbonate, as a solid carrier of hydrogen peroxide, with substoichiometric amount of molecular iodine, resulted in another convenient alternative of oxidative coupling synthesis of sulfonamides **2-45** (Scheme 15). However, it was demonstrated, that the addition of radical scavengers (TEMPO, BHT) retarded the formation of desired products, suggesting, the reaction proceeds via radical mechanism. Also, it was shown that such conditions are not compatible with the use of anilines (Scheme 15).⁶⁸

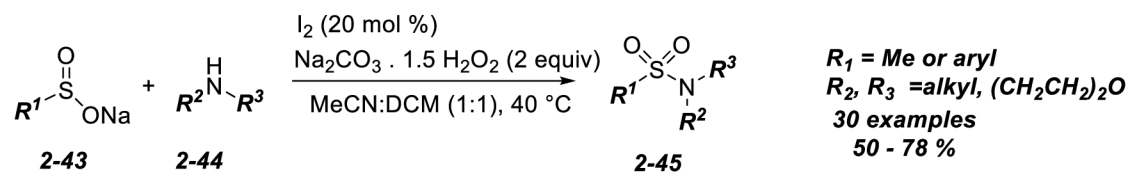

Scheme 15 – Sulfonamide synthesis – radical pathway

This method proved to be suitable for the *N*-sulfonylation of 1,2,4-triazoles **2-46** and benzotriazoles. On the contrary, substoichiometric amount of iodine had to be used and dioxygen then played the role of the external oxidizing agent (Scheme 16).⁶⁹

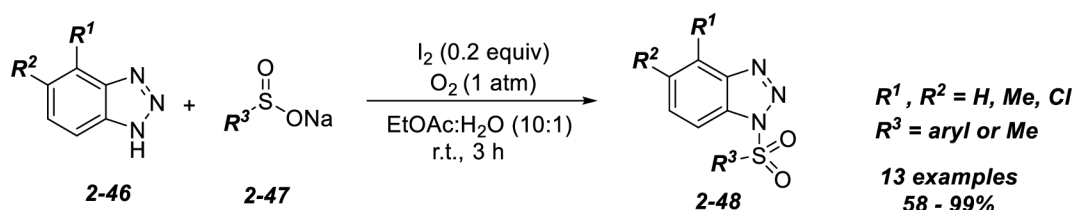

Scheme 16 – Synthesis of benzotriazole sulfonamides

Lai et al. reported very interesting approach to sulfonamides **2-55**, **2-59** based on the reaction with sodium *p*-toluenesulfinate **2-54** with tertiary amines **2-49**. Treatment of those with I₂ in the presence of TBHP in H₂O and *t*BuOH, *N,N*-disubstituted sulfonamides **2-55** were obtained. Interestingly, when the reaction was carried out in DMSO, β -arylsulfonyl enamine **2-55** was the product of the reaction. Since the addition of TEMPO inhibits the reaction, it is believed, it proceeds via radical mechanism. The authors proposed the I₂/I⁻ catalytic redox cycle based on the additional mechanistic studies. Under those conditions, tertiary amine **2-49** is oxidized to iminium cation **2-51** that is hydrolysed in the presence of water to aldehyde **2-52** and secondary amine **2-53**. Secondly, amine **2-53** then reacts with sulfonyl radical **2-54** to yield the sulfonamide **2-55** (Scheme 17, **Path A**). If iminium cation **2-51** can not be hydrolysed (DMSO),

generated enamine **2-56** then undergoes the addition of sulfonyl radical **2-54** and yields β -arylsulfonyl enamines **2-59** (Scheme 17, **Path B**).⁷⁰

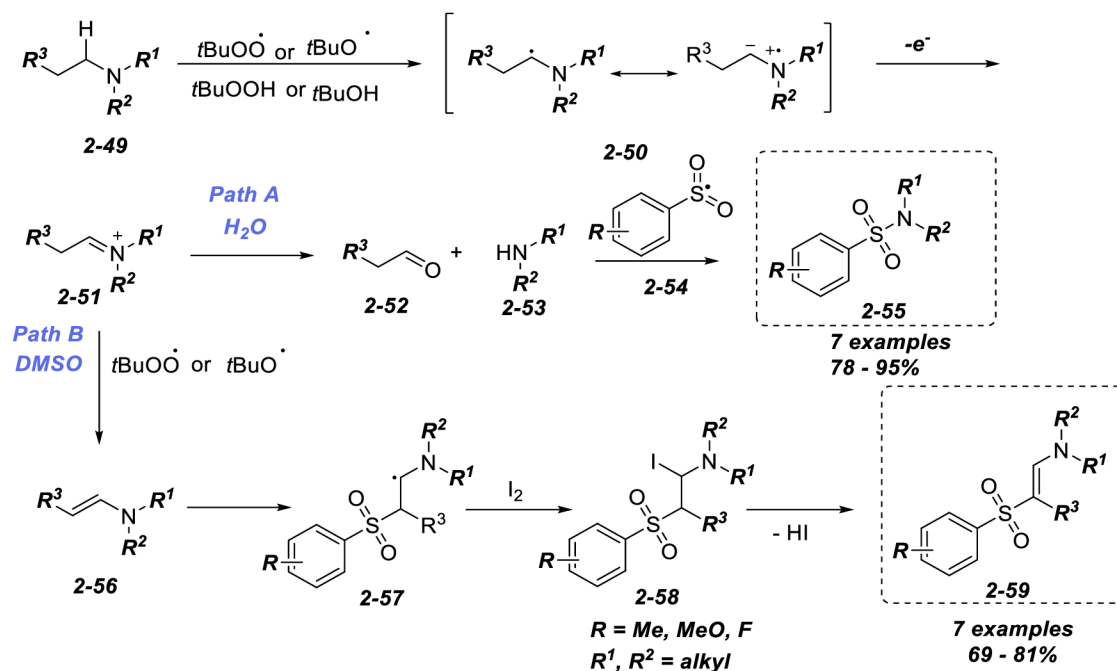

Scheme 17 – Plausible reaction mechanism of the sulfonamide formation that rationalize the role of solvents

If we consider the reaction mechanism of the TBAB/*m*CPBA system,⁷¹ based on the control experiments, the authors claim that the reaction is not proceeding via radical mechanism. Such observation is valuable because it is increasing the scope of the transformations to the radical-susceptible substrates (Scheme 18).

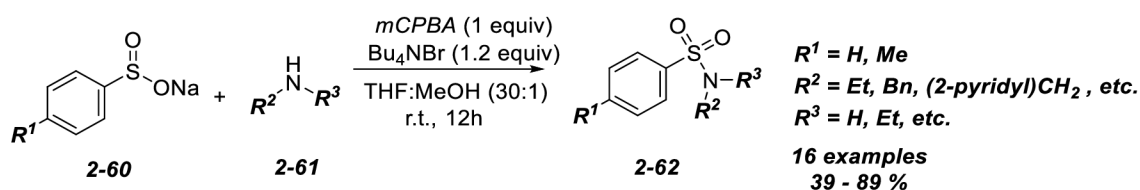

Scheme 18 – Oxidative coupling carried out by *m*CPBA and TBAB

Sulfonylation of benzimidazoles **2-63**, pyrazoles **2-66** was performed using NBS as an oxidizing agent. In case of benzimidazoles **2-63**, the desired products were formed in excellent yields and broad scope. However, in a combination with pyrazoles **2-66**, the reaction conditions led to the C₄ halogenation (I, Br) along with the sulfonamide **2-68** formation (Scheme 19).⁷²

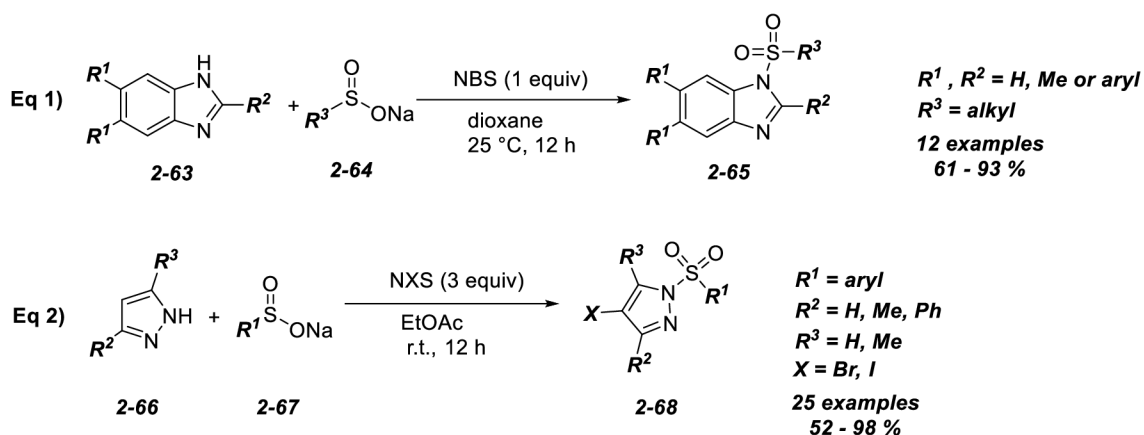

Scheme 19 – Reactivity of benzimidazoles in oxidative coupling reactions

Tang et al. developed another interesting CuBr_2 -mediated procedure for sulfonylation of amines **2-69**.⁷³ The proposed mechanism is based on the Cu(II) insertion to sulfur-bromine bond that undergoes the homolytical cleavage, resulting into free radical species **C**. In parallel, Cu(II) induces “ligand exchange” and formed $\text{R}_2\text{N-Cu-Br}$ intermediate **B**, that upon the reaction with sulfinate radical **C** yields the desired sulfonamide **2-71** (Scheme 20).

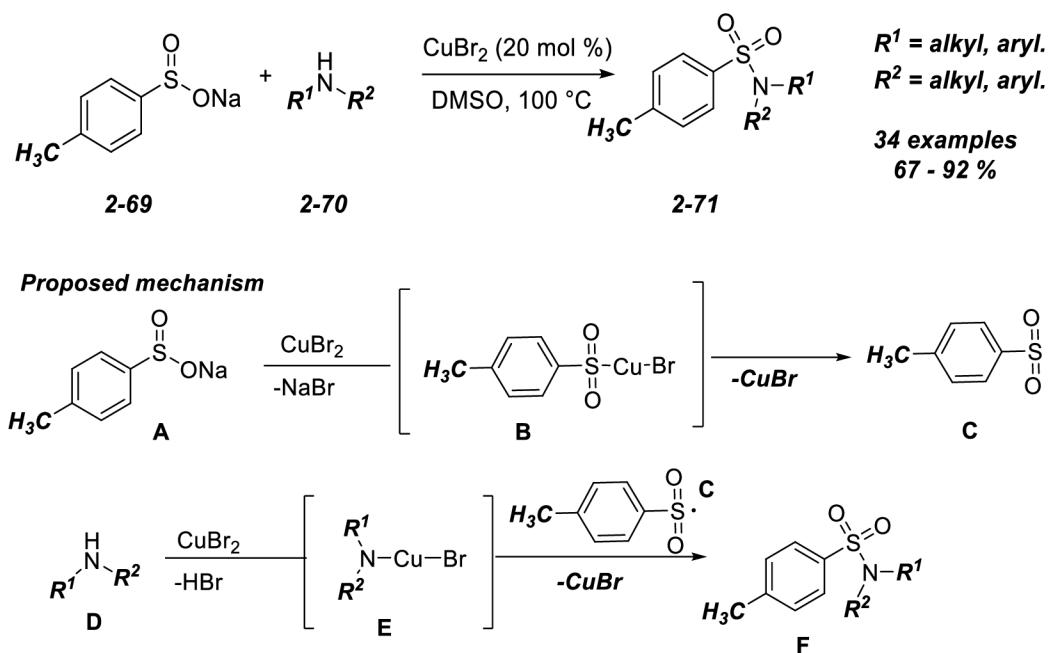
Scheme 20 – Plausible mechanism for CuBr_2 mediated reaction

Iron catalyzed coupling of nitroarenes **2-73** and sodium arylsulfinate **2-72** developed by Zhang et al. provided a novel route to sulfonamides **2-74**. The reaction is catalysed by Fe(II) ions and NaHSO_3 played a role of a reductant. Proposed reaction mechanism of the transformation is shown in Scheme 21.⁷⁴

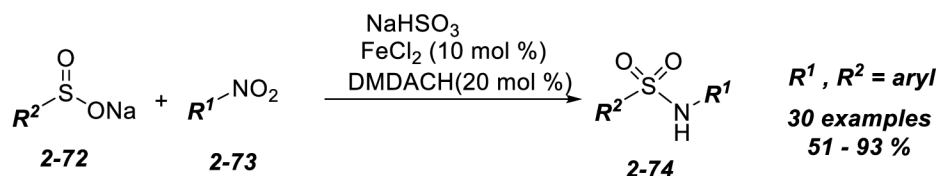
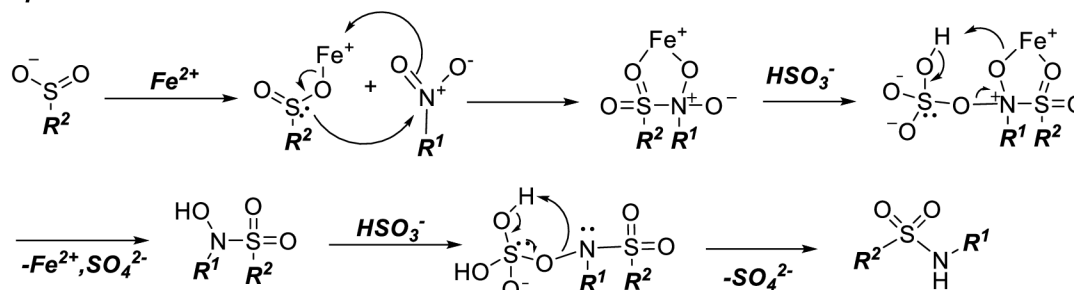
**Proposed mechanism**

Scheme 21 – Reactivity of nitro compounds in iron catalysed sulfonamides preparations

Similarly, sulfinic salt can be in situ generated from arylboronic acid **2-75** and pyrosulfite. If copper(I) and nitroaryl **2-76** is present, sulfonamides **2-77** are formed (Scheme 22).⁷⁵

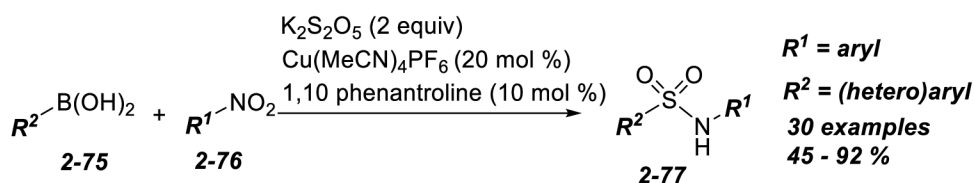
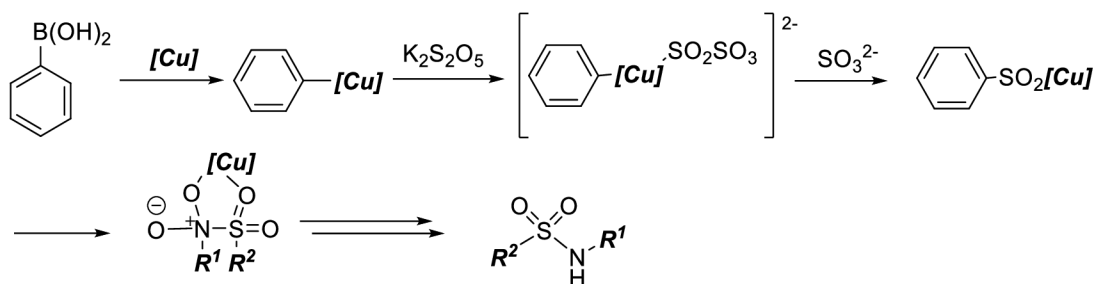
**Proposed simplified mechanism**Scheme 22 – Reactivity of boronic acids in $\text{K}_2\text{S}_2\text{O}_5$ /[Cu] catalysed sulfonamide preparation

In recent years, the chemistry synthesis has put a higher impact on the safety and ecological questions. From that perspective, electrochemical oxidation/reduction protocols might be a great solution towards sustainable and “safer” world. In general, electrochemistry-based methods are usually broadly substrate-tolerant and provide transformations with an excellent atom economy. E.g. electrochemical oxidation of 2,5-diethoxy-4-morpholinoaniline **2-78** that proceeds in the presence of arylsulfinic acids provides sulfonamides **2-80** in moderate yields (Scheme 23).⁷⁶

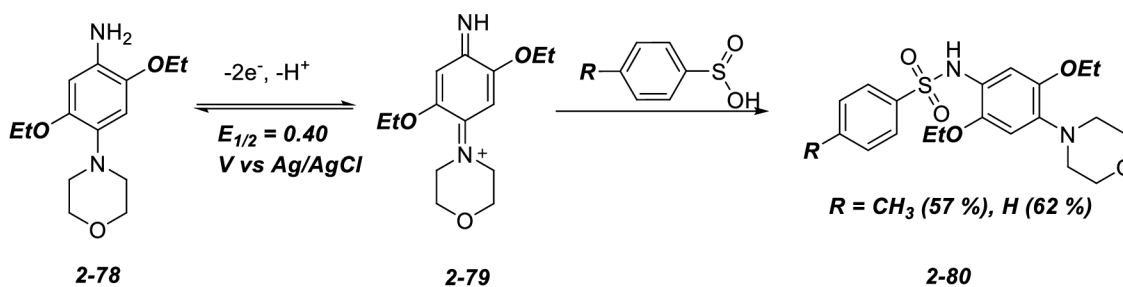

Scheme 23 – Electrochemistry-based oxidative coupling of anilines and sulfinic salts

Using this method, a wide range of sulfonamides **2-83** can be prepared.⁷⁷ The coupling proceeds in an undivided cell with methanol and in the presence of NH_4I that plays a role of supporting electrolyte and redox catalyst. Such protocol is using current density of 5 mA/cm^2 and is useful for oxidative aminations of primary aliphatic amines **2-82**. The proposed mechanisms of the transformations are comparable with the previously mentioned methods and differ only in the “oxidizing agent” - graphite anode (Scheme 24).

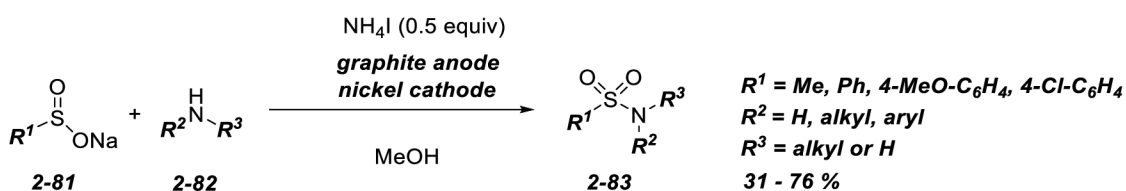

Scheme 24 – Electrochemical oxidative coupling of sulfinic salts and amines

Similar conditions for sulfinic salts and amines coupling were used by Terent'ev et al.⁷⁸ NH_4Br was used as supporting electrolyte and the redox catalyst in a combination with iron cathode in an undivided cell. Additionally, simple access to sulfonamides **2-87** use a one-pot reaction of Rongalite®. The reaction provides sulfonamides via sulfinic salt **2-86** generation and its subsequent oxidation with DCDMH in the presence of amines (Scheme 25).⁷⁹

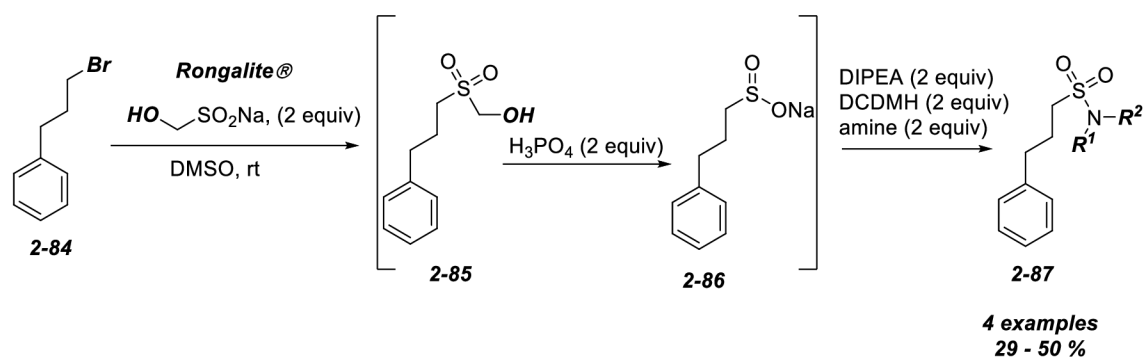

Scheme 25 – Oxidative coupling using Rongalite®

Finally, enzymatic oxidative coupling promoted by Laccase was reported by Rahimi and co-workers.⁸⁰ These copper-based polyphenol oxidases promote oxidative coupling of 4-substituted urazoles **2-88** and sodium sulfonates (Scheme 26).

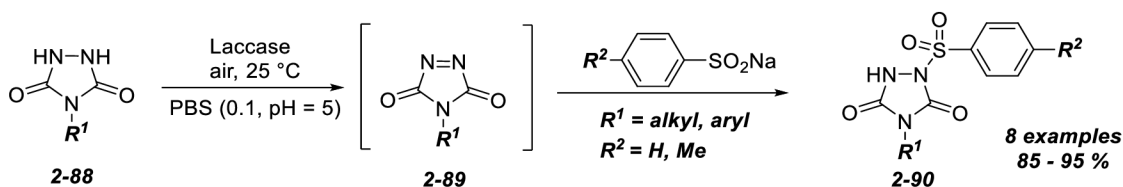

Scheme 26 – Enzymatic oxidative coupling

2.3.2.2 Synthesis of sulfonamides from sulfonylhydrazides

Sulfonylhydrazides proved to be useful starting materials in sulfonamide synthesis. The main strength of sulfonylhydrazides is their air and moisture stability while preserving its high reactivity towards desirable transformations. The transformation of hydrazide species **2-91** into sulfonamides **2-93** proceeds via radical pathway with help of TBHP oxidant and substoichiometric amount of iodine or NH_4I ⁸¹ in DCE⁸² or without solvent.⁸³ The important step is the generation of arylsulfonyl radical that after dinitrogen elimination reacts with iodine. Generated sulfonyl iodide then reacts with amine that allows the preparation of *N*-aliphatic as well as *N*-aromatic sulfonamides **2-93** (Scheme 27).

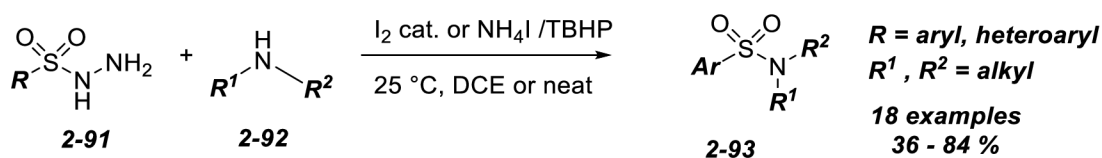

Scheme 27 – Iodine-based oxidative coupling of sulfonylhydrazides with amines

Terent'ev and co-workers adopted sulfonylhydrazide-based **2-94** synthesis to be compatible with electrochemical preparation of sulfonamides from sulfinic salts. In such case, the oxidative coupling was carried out in an undivided cell in the presence of NH_4Br or KBr as supporting electrolytes and provided excellent yields of *N*-aliphatic sulfonamides **2-96** (Scheme 28).⁷⁸

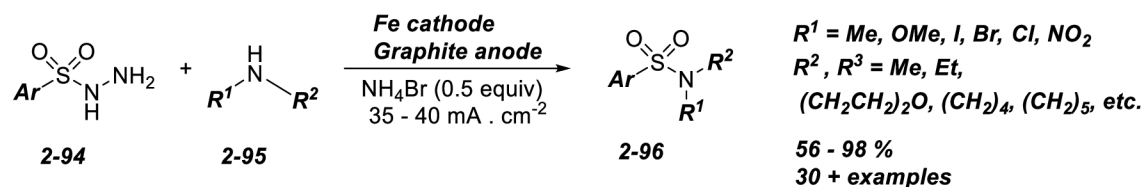

Scheme 28 – Electrochemical oxidative coupling of sulfonylhydrazides

Sulfonamides **2-99** were also accessed by electrochemical oxidation of sulfonyl hydrazides **2-97** in the presence of tertiary amines **2-98**. Mechanistic studies showed that Et_3N in a combination with sulfonyl hydrazide **2-97** were the electroactive substances. A hydrolysis of iminium cation, which is the product of the oxidation, produced secondary amine that underwent substitution with sulfonyl chloride and yielded the targeted sulfonamide **2-90** (Scheme 29).⁸⁴

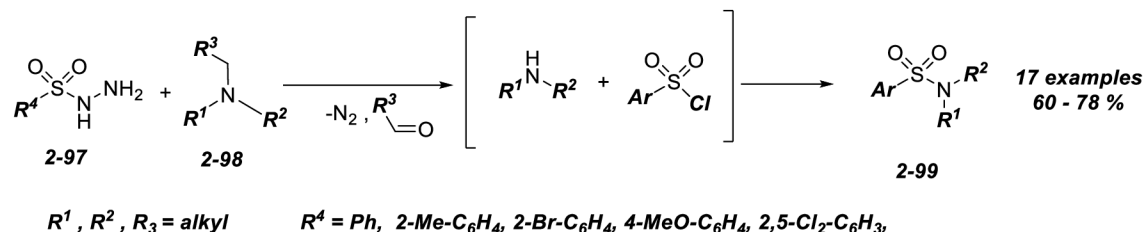

Scheme 29 – Oxidative coupling of sulfonyl hydrazides and tertiary amines

2.3.2.3 SO₂ direct insertion methods

Direct sulfonyl group incorporation into *carbon-nitrogen* bond has found an important place among the synthetic routes leading to sulfonamides. This method is popular because it explores the use of non-toxic alternative of SO_2 . Among bench stable solid surrogates of SO_2 1,4-diazabicyclo[2.2.2]octane-bis(sulfur dioxide) is the most exploited $\text{SO}_{2(\text{g})}$ alternative (Figure 12).⁸⁵ Since recently, many new synthetic methods have become to use this reagent that leads to exploring its full potential.

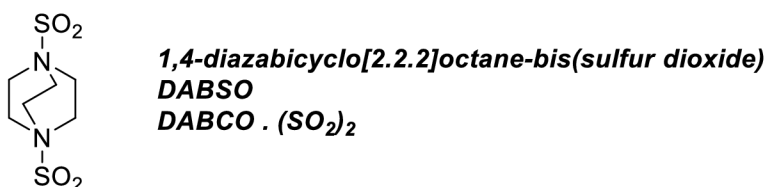
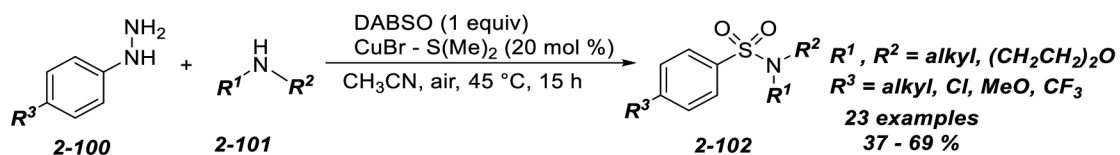
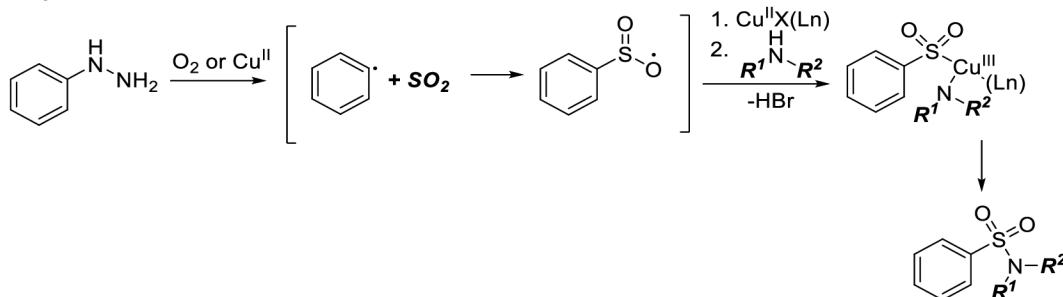
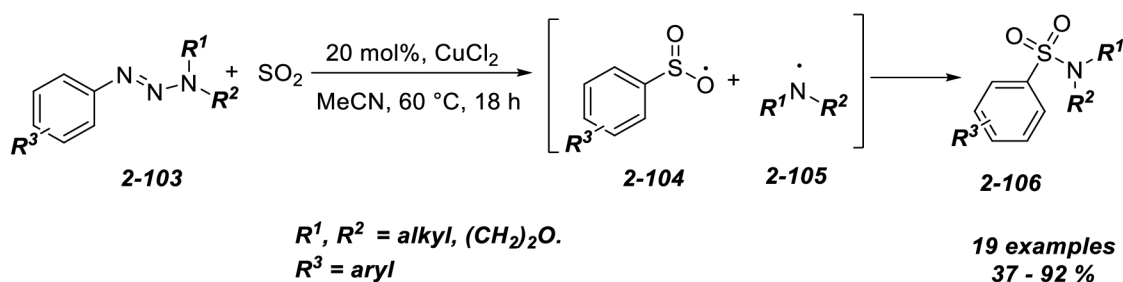

Figure 12 - Structure of DABSO

Very useful approach to sulfonamides based on the use of DABSO starts with the chemoselective transformation of phenyl hydrazines **2-100** that are in the presence of copper catalyst transformed to sulfonamides **2-101**. Based on the brief mechanism examination, authors proposed that phenyl radical is generated first and reacts with SO₂ to form arylsulfonyl radical. Generated radical triggers the formation of Cu(III) complex that after amine/Br⁻ ligand exchange and reductive elimination yields the desired sulfonamide (Scheme 30).⁸⁶

**Proposed mechanism**Scheme 30 – DABSO-based sulfonamide synthesis catalysed by CuBr.S(Me)₂

Li and co-workers developed Cu(II) catalysed de-nitrogen/sulfonylation reaction that is based on the transformation of triazenes **2-103** (sources of amino **2-105** and aryl radicals) that after incorporation of SO₂ reaction with presented amine yielded sulfonamides **2-106**. In contrast with previously described methods, a solution of SO₂ in MeCN was used as the source of sulfur dioxide (Scheme 31).⁸⁷

Scheme 31 - CuCl₂ catalysed synthesis of sulfonamides

Sulfonamide synthesis based on the use of organometals was reported by Deeming et al.⁸⁸ At this point, generated organometallic reagent **2-107** (Zn, Mg, Li) were reacted with DABSO and *N*-chloroamines **2-110**. Anilines and amino acids **2-109** are suitable substrates for this transformation. In contrast with above-mentioned proposed mechanism (via sulfonyl chloride), in this case, the authors considered in situ formation of *N*-chloramine that reacted with sulfinic salt **2-108**. The expected mechanism was not explicitly proven, moreover, reactions with individually prepared *N*-chloramine were not successful (Scheme 32).

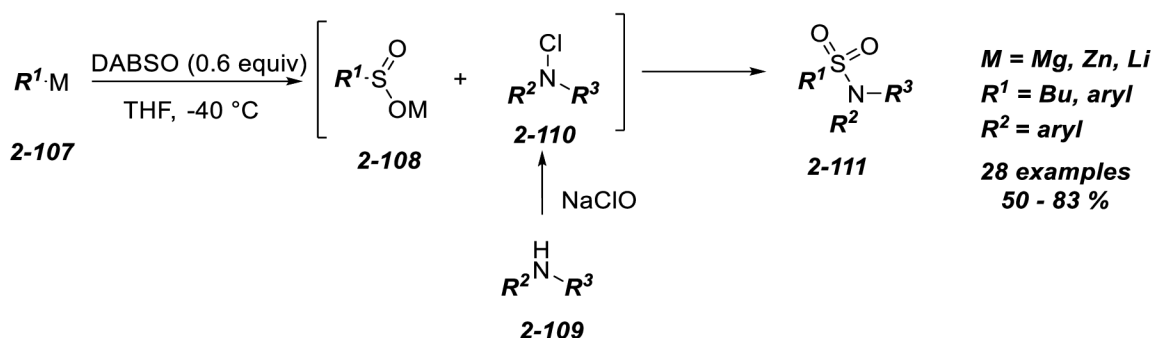

Scheme 32 – Organometallic reagent based sulfonamide preparation

In 2016, the metal-free DABSO-based transformation of hydrazones **2-112** was described.⁸⁹ The cyclic secondary amines yielded the sulfonamides **2-113** in high yields, on the contrary, anilines provided sulfonamides **2-113** only in traces (Scheme 33).

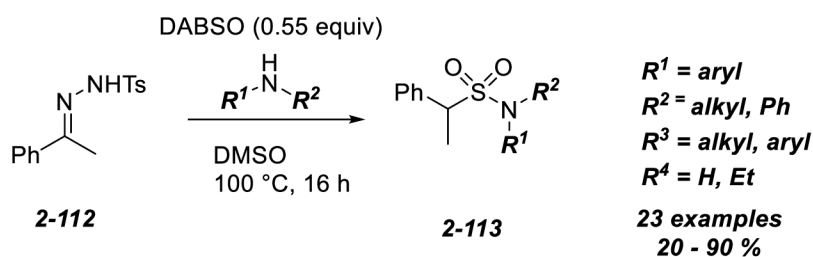

Scheme 33 – Preparation of sulfonamides from tosyl hydrazones

Elucidation of the reaction mechanism suggested that radical pathways are improbable. The authors then proposed three probable ionic pathways. **Path A** is based on the nucleophilic properties of diazo species **2-115** and electrophilic properties of “SO₂”. The reaction then leads to sulfene **2-117** intermediate that is then trapped by amine. **Path B** then expects the protonation of diazo species **2-115** and nucleophilic displacement in SO₂-amine complex **2-119**. The last option (**Path C**) is based on the ene reaction between aryl hydrazone **2-112** and SO₂, that after decarboxylation provides sulfene **2-117** that reacts with amine (Scheme 34).⁸⁹

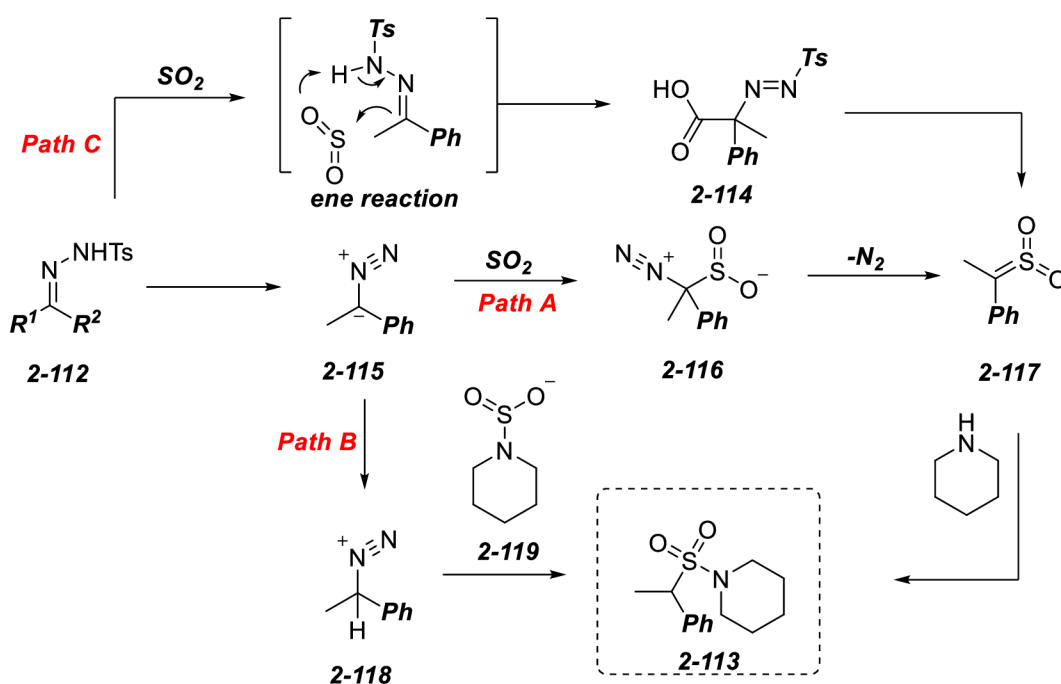

Scheme 34 – Three plausible ionic pathways of tosylhydrazone – sulfonamide transformation

2.3.3 Sulfonamide synthesis from thiols

Since previously mentioned methods are so broadly applicable, thiol-based synthesis was explored in the literature only in very limited number of examples. However, in recent years it has gathered some attention from medicinal chemists. The formation of S-N bond prior the oxidation to sulfonamide **2-117** is very convenient and high-yielding in case of aliphatic amines. Unfortunately, the oxidation step allows only limited possibilities when available reagents are considered. This step is thus the main limitation of this approach. The *sulfur-nitrogen* bond is available from the reaction of thiol **2-120** with free amine and ideal oxidant, usually *N*-halosuccinimide.⁹⁰ Alternatively, sodium hypochlorite,^{91,92} gaseous chlorine⁹³ or electrochemical oxidation⁹⁴ can be used to achieve such

transformation and the oxidation is usually carried out with *m*CPBA, KMnO_4 or Ru-based oxidants (Figure 13).

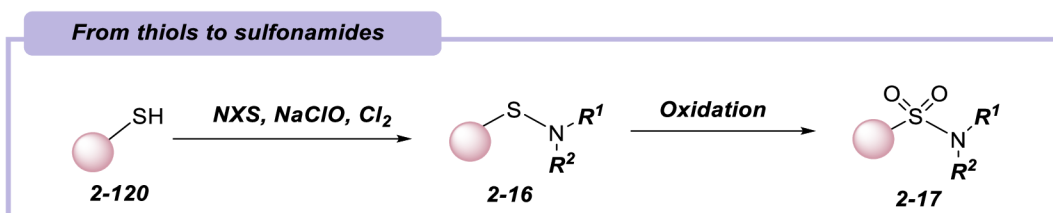
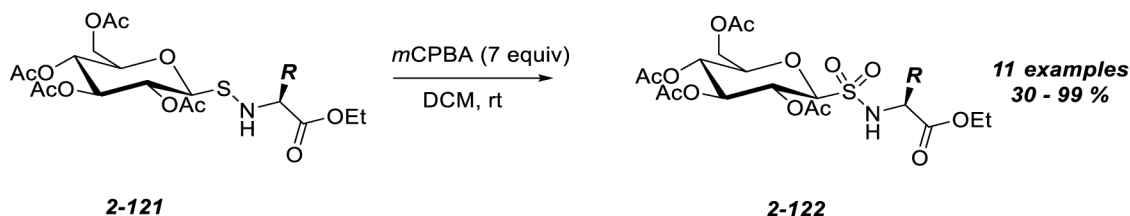

Figure 13 – Thiol-based sulfonamide synthesis that proceeds via sulfenamide

In the following example, Poulsen et al. used such approach in the synthesis of amino acid building blocks.⁹⁵ *m*CPBA was used as the oxidant and provided sulfonamides **2-122** in great yields (for most derivatives >80 %) (Scheme 35).



Scheme 35 – α -aminoacid sulfonamide derivatives synthesis

Using similar procedure, pyridazinone heterocycle-containing sulfenamides **2-123** were oxidized to the corresponding sulfonamides **2-124**. Obtained compounds were tested as CB_1 receptor ligand antagonists (Scheme 36). Again, *m*CPBA provided very chemoselective oxidation that resulted in sulfonamide **2-124** formation in 40 – 71 % yield (Scheme 36).⁹¹

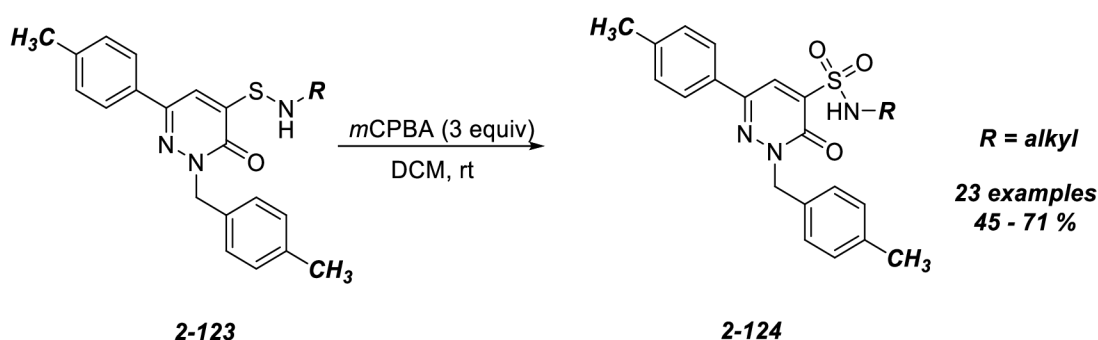

Scheme 36 – *m*CPBA-based oxidation of pyridazinone derivatives

Another widely used oxidative conditions are based on the use of RuCl_3 and NaIO_4 . The sulfenamide **2-125** oxidation was accompanied with oxidative cleavage of double bond (Scheme 37).⁹⁶

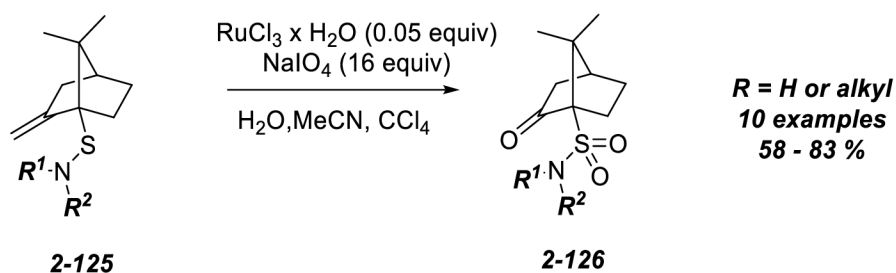

Scheme 37 – Ru-based sulfenamide oxidation

Finally, the oxidation can be carried out either in the presence of $\text{KMnO}_4/\text{CuSO}_4$ system (Eq 1, Scheme 38).⁹⁸

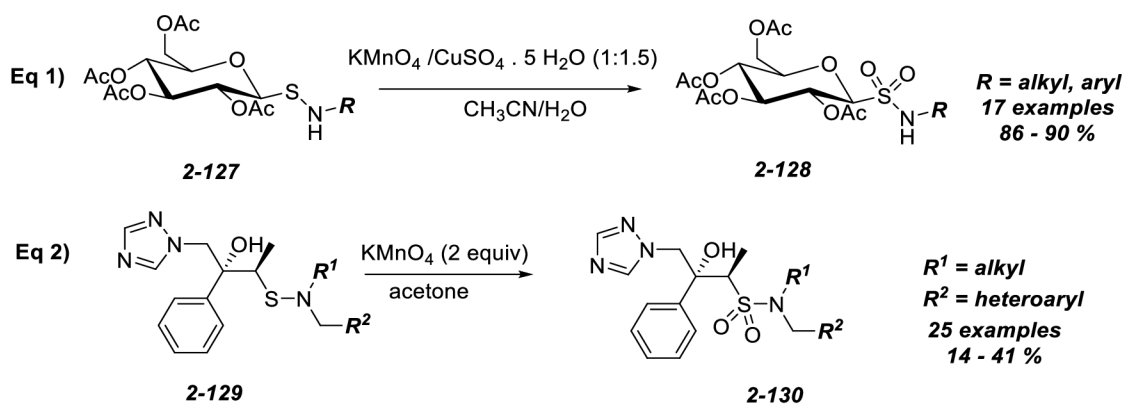
Scheme 38 – Oxidation of sulfenamides with KMnO_4 and $\text{KMnO}_4/\text{CuSO}_4 \cdot 5\text{H}_2\text{O}$

2.4 Sulfonamides in organic synthetic methodology

Sulfonamide functionality does not have only strong position among biological active compounds; they are also important starting motive for several synthetic transformations. Due to relatively high acidity of sulfonamidic proton ($pK_a < 8$), the sulfonamidic nitrogen can serve as the nucleophile in the well-known Fukuyama-Mitsunobu alkylation (Scheme 39). It is a well-known concept with literary hundreds of examples.⁹⁹

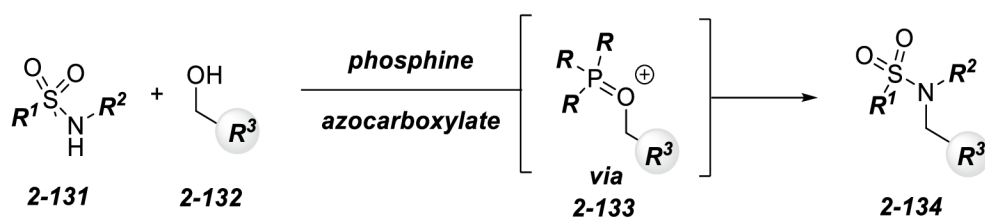

Scheme 39 – General scheme for Fukuyama-Mitsunobu alkylation

A Mitsunobu-like reaction, that transforms activated ketones to sulfonamides was reported by Maloney et al.¹⁰⁰ The reaction proceeds in the presence of phosphine and non-nucleophilic base and yields imines **2-139** and sulfinates **2-138**. Both products can be readily derivatized. This approach interestingly changed the conventional view on sulfonamides as a terminal functional group (Scheme 40).

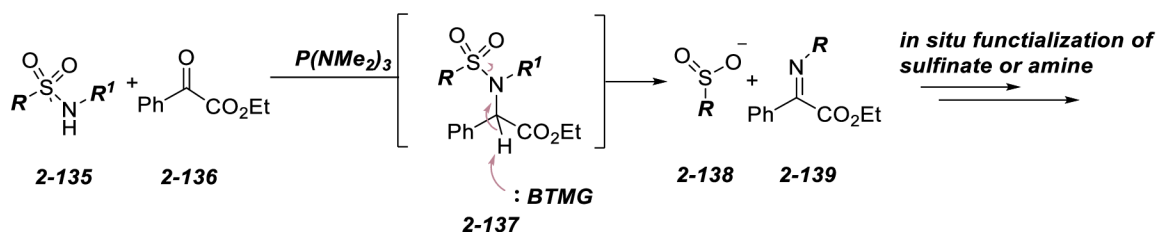

Scheme 40 – Utilization of sulfonamides as powerful reagents in further functionalization

Sulfonamides **2-140** can be used in the boron Mannich multicomponent reaction (The Petasis reaction) where sulfonamides **2-140** react with carbonyl compounds **2-141** in the presence of boronic acids **2-142**. Eventhough, the method is well established, the reaction mechanism is still uncertain and awaits for detailed investigation (Scheme 41).^{101,102}

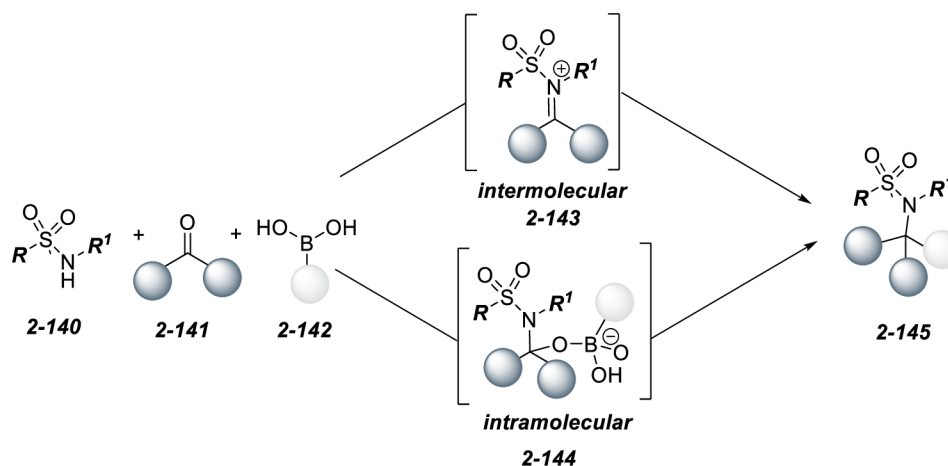

Scheme 41 – General scheme for Petasis reaction

2.4.1 The use of sulfonamides in the transition metal catalysed reactions

There are several reports of palladium and copper catalysed reactions, where *N*-alkylated sulfonamides **2-147** play a role of a substrate by reacting with boronic acid (Chan-Evans-Lam reaction)^{103,104} or arylhalides (Buchwald-Hartwig reaction).^{105,106} Compared to copper and palladium cross coupling reactions, nickel catalysed reactions of sulfonamides remain underdeveloped. The biggest obstacle for that is presumably the rate-limiting reductive elimination step from “Ni” intermediate. However, this limitation was recently overcome by photochemical approach by MacMillan¹⁰⁷ and Roizen.¹⁰⁸ The rapid energy transfer to Ni(II) intermediate occurs, and a formation of triplet-excited-state species induces the rapid reductive elimination. The reductive elimination step was also achieved if sterically demanding and modestly electron donating biphosphines (**DalPhos**) were used as a Ni-catalyst ligands (Scheme 42).¹⁰⁹

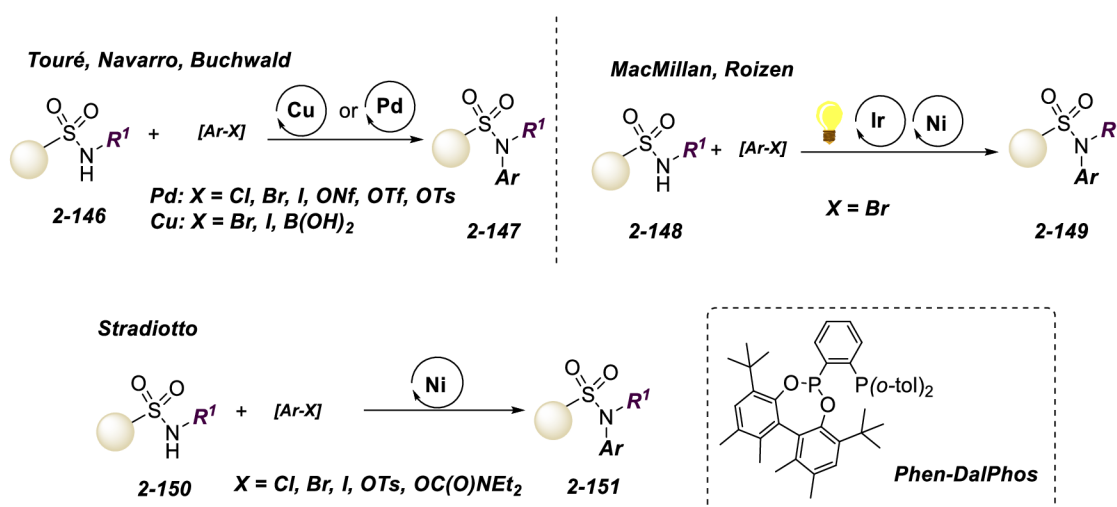

Scheme 42 – Application of sulfonamides in transition-metal catalysed coupling reaction

3 Plant secondary metabolites

Plant secondary metabolites are a heterogeneous group of natural metabolic products that are not essential for the life functions of plants but has a tremendous effect on the quality of their life. The production influences survival functions e. g. competitive weapons against bacterias, fungi, insects, metal transporting agents, sexual hormones or agents for symbiosis between microbes and plants, nematodes, insects etc.¹¹⁰ Up to date, there are known over 2 million of secondary metabolites, but only part of these were properly characterized. These metabolites are divided into classes based on their structure, function, and biosynthetic origins. Among the main classes of secondary metabolites belongs alkaloids, phenolic compounds, terpens and fatty acid-derivatives.¹¹¹

3.1 Phenylpropanoic compounds - lignans and neolignans

Phenylpropanoids are the largest group of plant secondary metabolites produced by higher plants. The name of this group is derived from aromatic phenyl group and the three carbons of the propyl chain. To this vast family belongs along with lignans and neolignans also flavonoids, coumarins, stilbenes and phenolic acids.¹¹²

3.1.1 Phenylpropanoid biosynthesis

Phenylpropanoid biosynthesis starts at the end of the plant shikimate pathway with non-oxidative deamination of phenylalanine **3-1** to *trans*-cinnamic acid **3-2**, catalysed by phenylalanine ammonia lyase and tyrosine ammonia lyase. The following step contains hydroxylation, catalysed by cinnamate 4-hydroxylase. This step is followed with generation of SCoA thioester of coumaric acid **3-4**, catalysed by 4-coumaroyl CoA ligase. This intermediate is the starting compound for further derivatization of coumaric acid derivative into monomeric phenylpropanoid subunits (e.g. sinapyl alcohol **3-12**, *p*-coumaryl alcohol **3-5**, coniferyl alcohol **3-10** etc.). These compounds are the main building blocks used in the generation of more complex lignans and neolignans units (Scheme 43).¹¹³

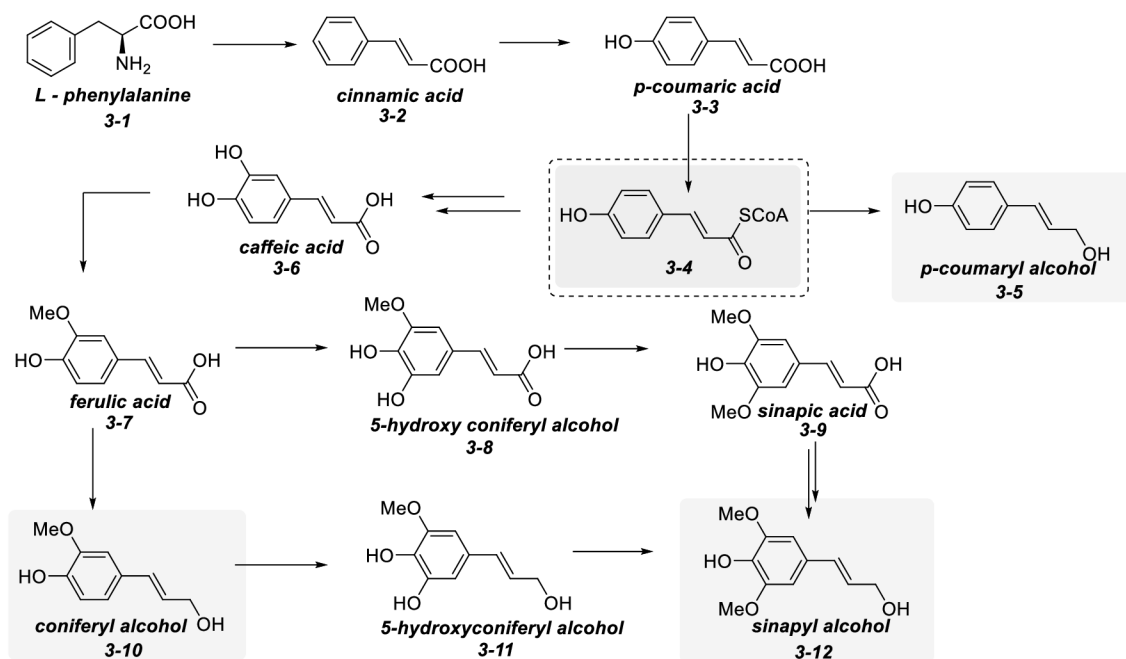

Scheme 43 – Simplified phenylpropanoids biosynthesis

3.1.2 Lignans and neolignans

Lignans and neolignans are phenylpropanoid dimers. The classification into the class of lignan or neolignan is based upon their coupling pattern. Dimers that are generated from C₈ and C_{8'} coupling process, with respect to the phenylpropanoid monomer, are called lignans. Any other possible products of the dimerization, are called neolignans (Figure 14).¹¹⁴

Lignans - basic structural motives

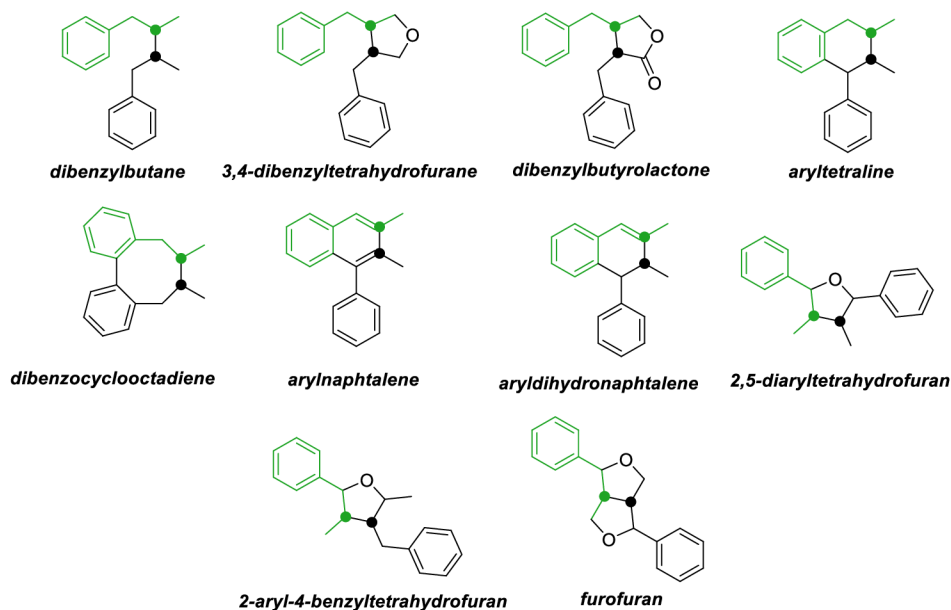

Neolignans - basic structural motives

Figure 14 – Basic structural motives of lignans and neolignans

The dimerization process proceeds via a radical mechanism mediated by laccases and peroxidases.¹¹⁵ The dimerization is initiated by an abstraction of a proton and an electron (redox process). Newly generated phenylpropanoid radical then, based on the substitution pattern, can readily dimerize via homocoupling process. Recombination that can occur in the position C₈ (*lignans*) or C₃ (C₅ if C₃ occupied – *neolignans*) (Figure 15).¹¹⁶

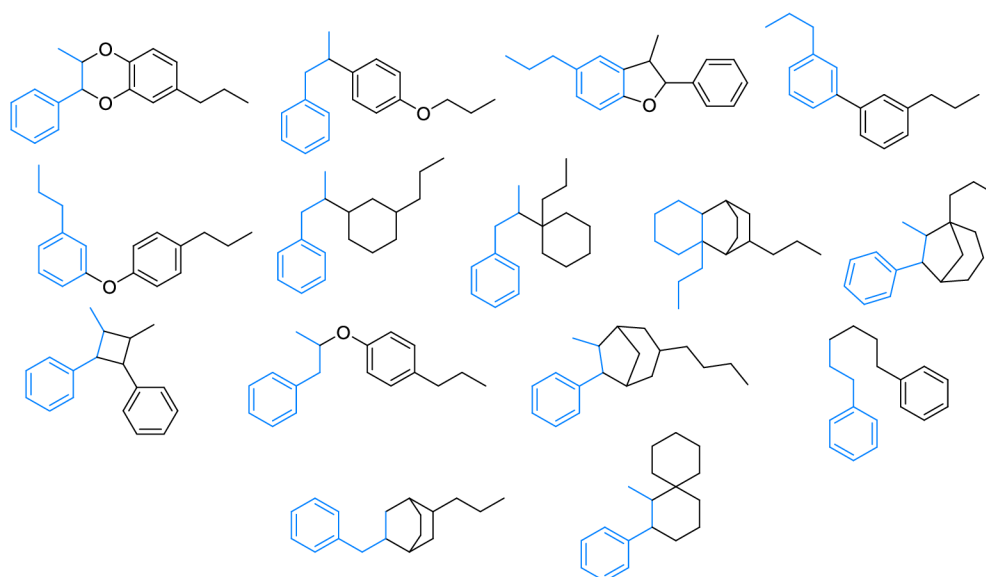
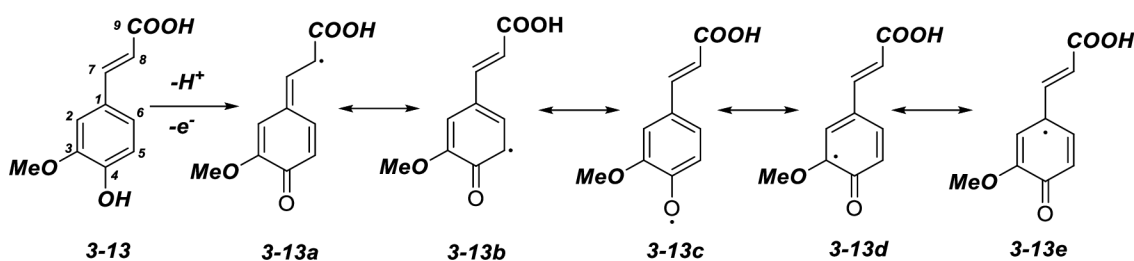
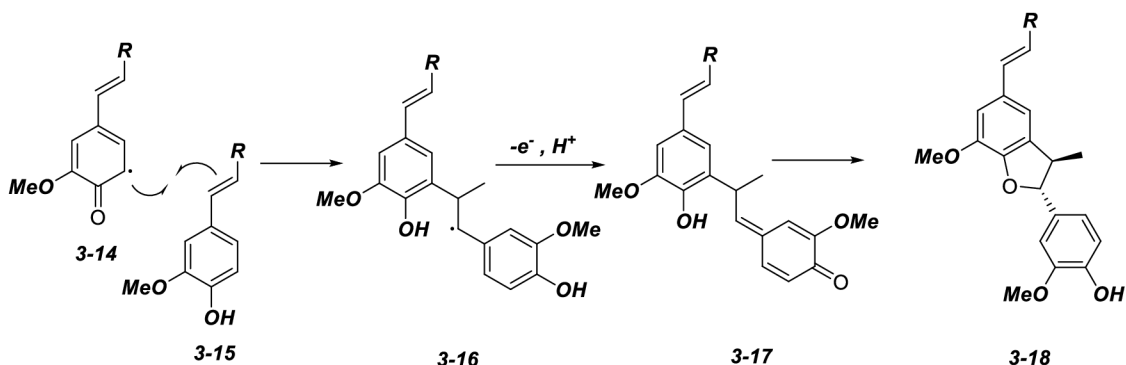

Figure 15 – Resonance structures of phenylpropanoid free radical (3-13)

3.2 (Dihydro)benzofuran formation (C₈, C_{5'}) dimerization - neolignans

Benzofuran core containing neolignans are one of the most abundant structural motives in nature. The reason behind their vast presence among many phenylpropanoid metabolites is presumably the mechanism of their biosynthesis. The reactive radicals **3-14** are generated at low concentrations, thus the addition to the double bond of phenylpropene is more probable than the radical recombination (C₈-C_{8'}). In addition, the

formation of a thermodynamically stable benzylic radical **3-16** drives the reaction towards benzofuran **3-18** formation as well (Scheme 44).¹¹⁷



Scheme 44 – Homocoupling of phenylpropanoid units

3.2.1 Biomimetic (radical) synthesis of dihydrobenzofurans

In vivo synthesis of benzofuran neolignans inspired scientist towards the development of biomimetic approach. Several biomimetic approaches based on various radical initiators were thus described. As is depicted on the dimerization mechanism, the phenolic group in *para* position is mandatory to achieve dimerization. As a consequence, only a few phenylpropene derivative can be used as substrate (e.g. ferulic, coumaric or caffeic acid). There are two main classes of “oxidants” that are used to promote dimerization coupling. The first one is based on the use of enzymatic oxidants (peroxidases,¹¹⁸ laccases¹¹⁹). The second one explores the use of metal base oxidants such as Ag₂O, FeCl₃.^{120,121} The main drawback that hammers the expensive use of these two approaches is the reproducibility (also based upon our experience), low reaction yields and the formation of several side products. In addition, the formation of oligomers increases the difficulties in terms of purification of the desired products. Considering C₈-C_{5'} neolignan **3-18** synthesis, the main sideproducts of the reaction are 8-*O*-4' **3-19** and 8,8' neolignans **3-20**. The dimers, that formation can be readily rationalized via the radical stability of reaction intermediates. To exemplify this situation, the biomimetic reaction conditions, yields and the ratio between the products are depicted in the Table 1.

Table 1 – Biomimetic approach to isoeugenol

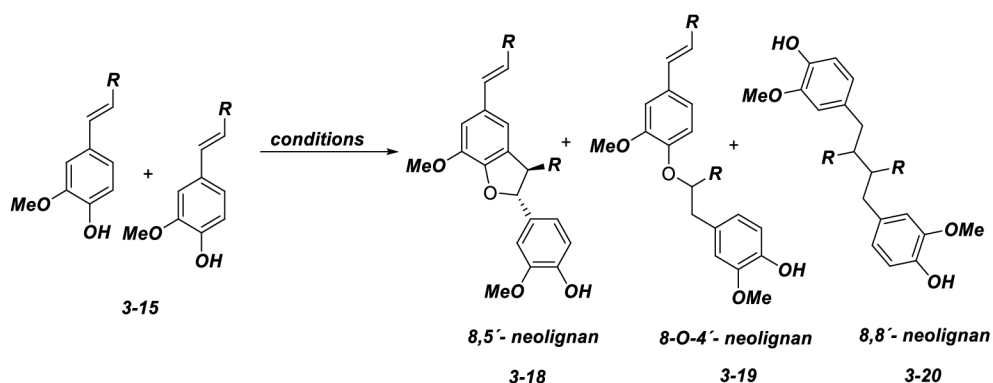

Entry	Conditions	8,5' ^{a)}	8-O-4' ^{a)}	8,8' ^{a)}	Ref
1	Laccase (<i>Rhus vernicifera</i>)	43 %	22 %	n.d.	119
2	FeCl ₃	53 %	n.d.	2 %	120
3	Mn(III)TPP acetate/iodosylbenzene	10 %	n.d.	n.d.	121
4	UV/Proflavin	42 %	40 %	n.d.	122
5	HRP/H ₂ O ₂	56 %	22 %	13 %	118

a) HPLC-based reaction yields, nd - product not detected

3.2.2 Synthetic approaches towards substituted (dihydro)benzofurans

There are only a few straightforward methods for the preparation of *anti* 2,3-disubstituted dihydrobenzofurans from readily available precursors. On the other hand, there is plenty of reactions describing formation of benzofuran ring. From that reasons, such *anti* 2,3-disubstituted dihydrobenzofurans can be then readily prepared by reduction of benzofuran ring. The aim of the following chapter is not to fully summarize all known approaches, but just briefly point out the most important and the interesting ones towards both benzofurans and dihydrobenzofurans.

3.2.2.1 Dihydrobenzofuran preparation - [4+1] annulations

The most straightforward method for 2,3-disubstituted dihydrobenzofurane **3-24** preparation is probably [4+1] annulation of quinone methides **3-21** with α -functionalized ketones **3-22** that yields dihydrobenzofuranes **3-24** with excellent enantiomeric and diastereomeric ratio (Scheme 45).¹²³

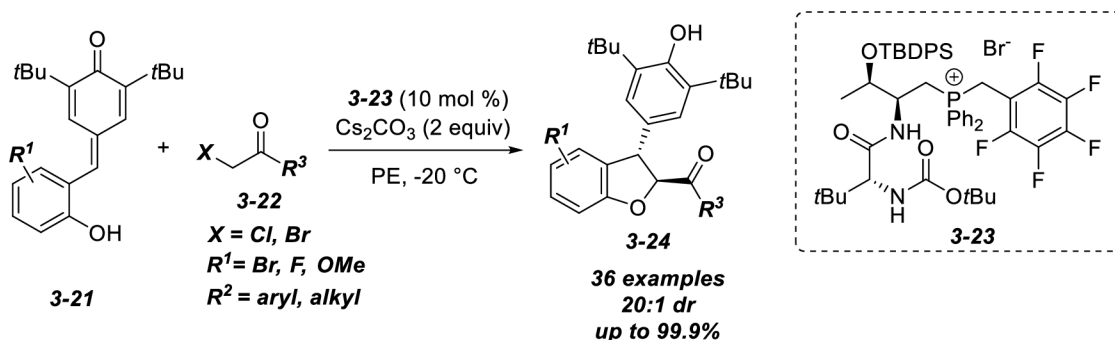

Scheme 45 – Preparation of 2,3-disubstituted benzofurans

Lei et al. developed a method for dihydrobenzofuran **3-27** preparation from the reaction of sulfur ylides **3-26** and 2-tosylalkyl phenols **3-25**. The quinone methide is generated in situ under basic conditions and readily reacts with sulfur ylide **3-26**, yielding benzofurans **3-27** in great yields (Eq 1, Scheme 46).¹²⁴ Quinone methides can be also generated from phenolic Mannich bases **3-28** and can undergo [4+1] cycloaddition in a reaction with pyridinium ylides **3-29** (Eq 2, Scheme 46).¹²⁵

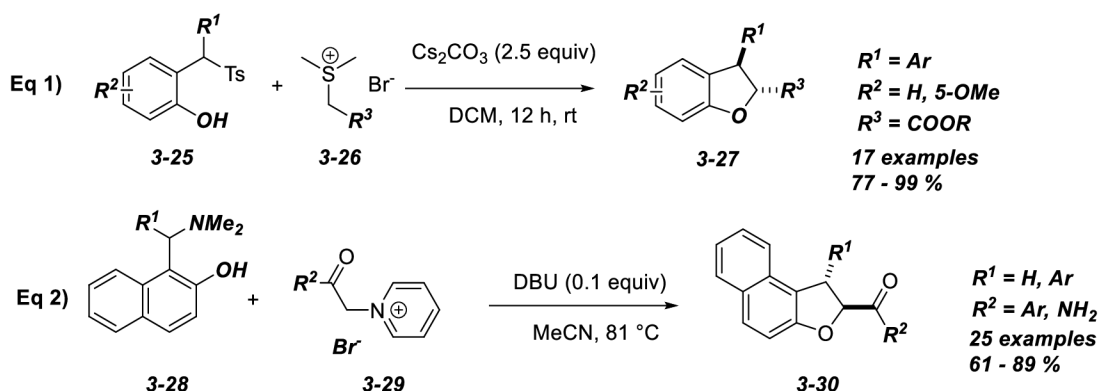

Scheme 46 – dihydrobenzofuran preparation from 2-tosylalkyl phenols

3.2.2.2 Preparation of dihydrobenzofurans - reduction of benzofurans

As was mentioned above, the synthesis of 2,3-dihydrobenzofurans **3-32** based on the reduction of the benzofuran skelet **3-31** is very convenient approach with broad functional group tolerance. Its advantage lies in nearly limitless number of possibilities towards benzofuran core synthesis that allows preparations of substrates with various substituents. The *anti* reduction can be carried out with magnesium as the reducing agent (Scheme 47).^{126,127}

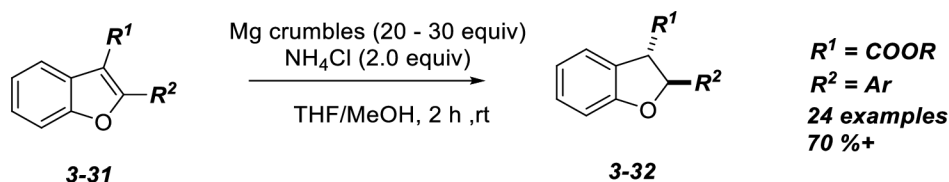

Scheme 47 – Anti reduction of benzofurane ring

3.2.2.3 Preparation of benzofurans - Intramolecular cyclization

The key step of the benzofuran **3-34** formation is in this case the intramolecular cyclization of the OH-nucleophile (phenol) **3-33** to alkyne or its synthetic equivalent. To successful success in this formally 5-exo dig(trig) cyclization, activation of the unsaturated function is required. In this context, along with plethora transition-metal based Lewis acids, $\text{PhI}(\text{OAc})_2$ showed to be a very powerful promoter.¹²⁸ The reaction with $\text{PhI}(\text{OAc})_2$ can be carried out also in catalytic fashion (*m*CPBA used as an oxidant) (Scheme 48).¹²⁹

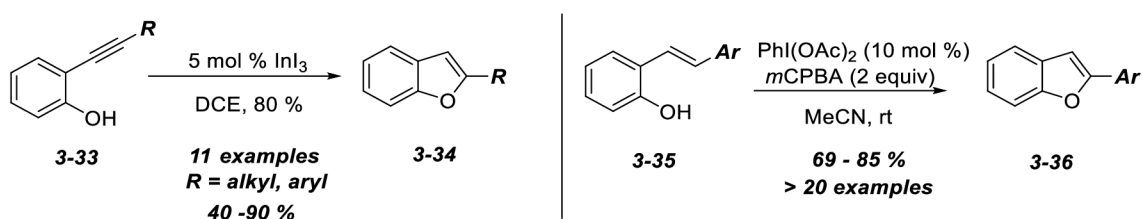

Scheme 48 – Intramolecular cyclizations of substituted phenols

Propargyl alcohol derivative **3-37** can also serve as the substrate for benzofuran **3-39** synthesis. In this case, Pd catalyst serves as the Π bond activator. Isocyanide was added to the reaction in order to prevent early protodepalladation via formation of cyclization intermediate **3-38** (Scheme 49).¹³⁰

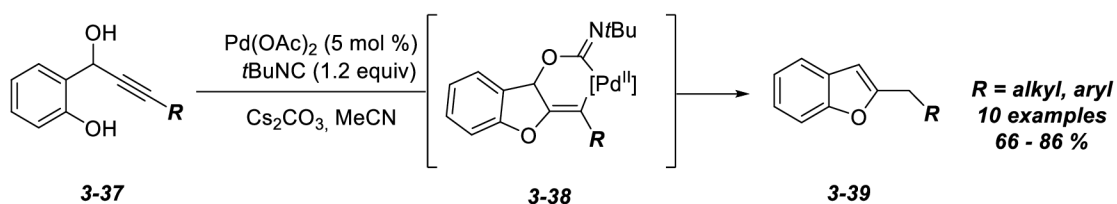

Scheme 49 – Pd catalysed annulation

In my view, the real beauty of chemistry is shown in the transformation of hydrazones **3-40** into benzofurans **3-42**, catalyzed by copper salt. This approach combines the specific reactivity of copper catalysed reactions (in situ formation of copper acetylide **A**) and copper carbenoid. The in situ formed allene **E** then sets up the scaffold required for intramolecular cyclization, that successfully accomplish the sequence (Scheme 50).¹³¹

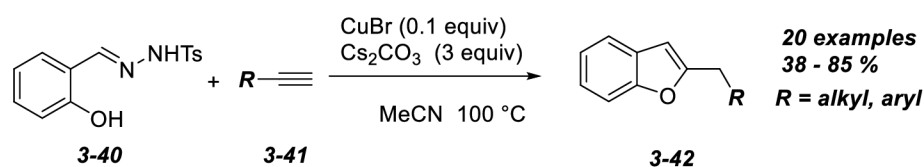

Proposed catalytic cycle

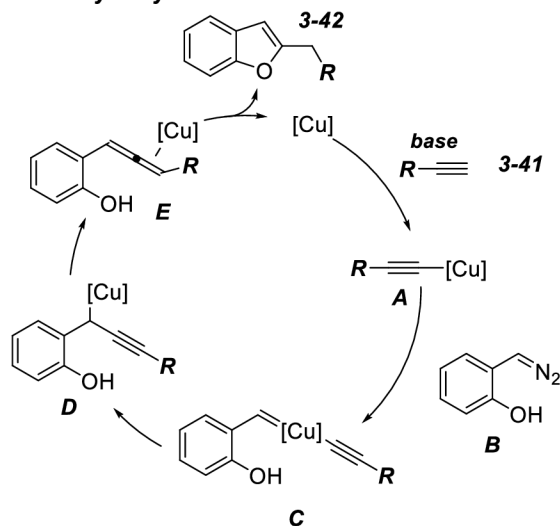

Scheme 50 – CuBr promoted benzofuran preparation

Another, very efficient copper catalyzed approaches based on the intramolecular cyclization explores the reactivity of aromatic ketones **3-42**. Two nearly identical protocols independently described the preparation of mono and disubstituted benzofurans **3-43**, **3-45** (Scheme 51).^{132, 133}

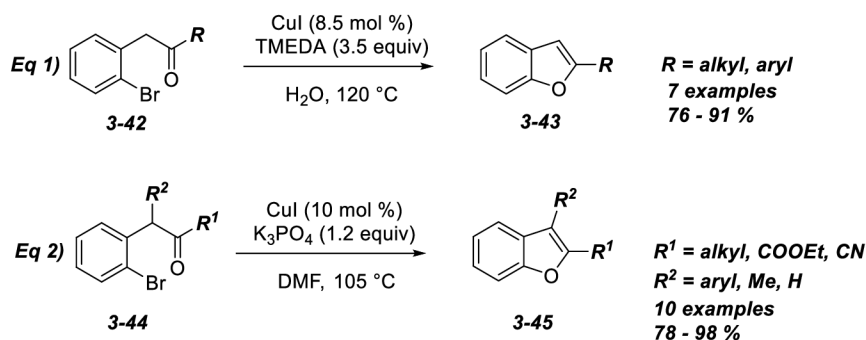

Scheme 51 – Copper-mediated approach to benzofurans

3.2.2.4 Preparation of benzofuranes - C-H functionalization

Recently, several benzofuran **3-49** preparations based on the transition metal-catalysed promoted annulations were described. The following examples show the use of palladium catalysis based transformations that use copper(II) salts as the co-oxidant. Sahoo et al. used substituted phenols **3-47** together with alkynes **3-48** as the substrates that in the presence of Pd salts yielded benzofurans **3-49** in excellent yields. The authors postulated

two plausible mechanisms that would explain observed transformation. The first one is based on the Wacker-type oxidation process that is followed by C-H insertion of [Pd] species. The second possibility is that Pd(II) undergoes *ortho*-palladation followed by carbometallation onto the alkyne **3-48** (Scheme 52).¹³⁴

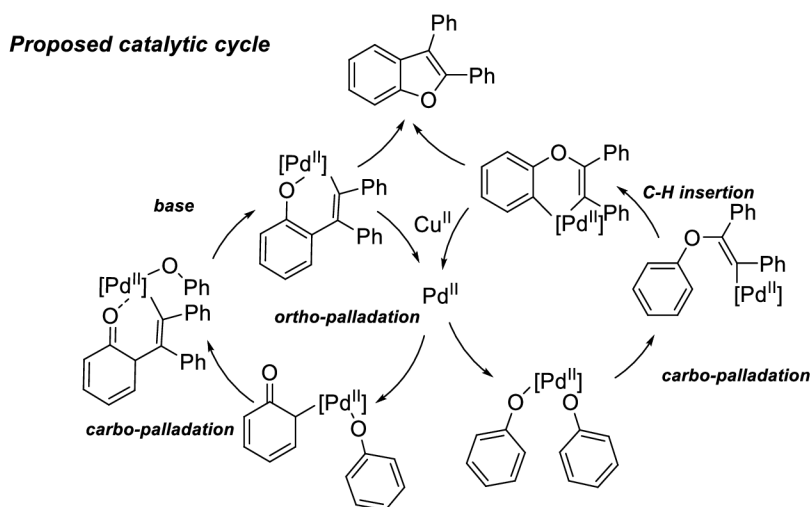
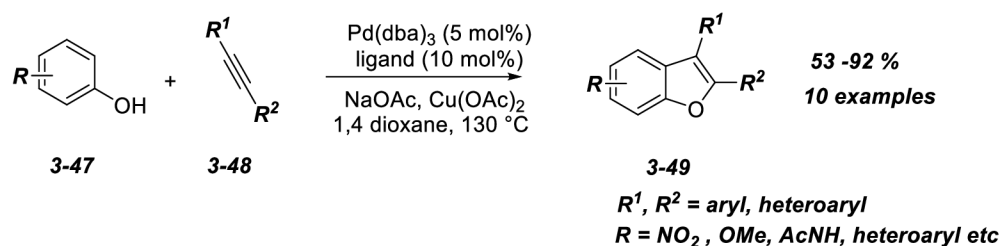

Scheme 52 – Palladium catalyzed annulation

Similar conditions were developed for the annulation of phenols **3-50** and styrenes **3-52**. The authors also expect that the similar reaction mechanism (*ortho*-palladation followed by carbopalladation) governs the reaction (Scheme 53).¹³⁵

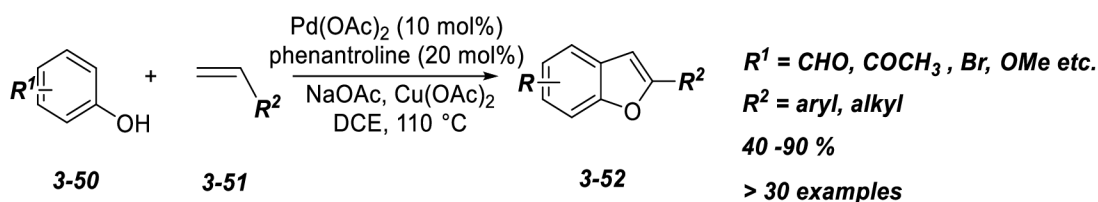

Scheme 53 – C-H activation catalysed by palladium

A selective synthesis of benzofurans **3-55** substituted in the position 3 was described by the group of Maiti. The regioselectivity of the reaction was in this case reversed by the addition of cinnamic acid derivatives **3-54**. The proposed reaction mechanism includes a decarboxylative step, followed by β -elimination and cyclization as a key step of the transformation (Scheme 54).¹³⁶

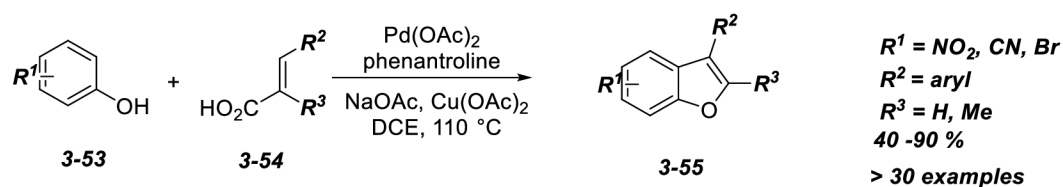

Proposed catalytic cycle

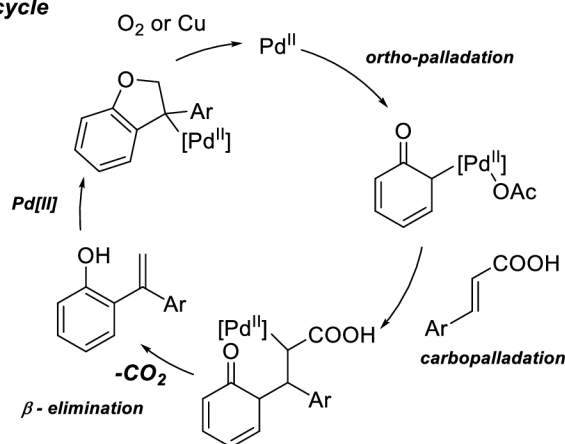

Scheme 54 – Wacker-type benzofuran synthesis

3.2.2.5 Preparation of benzofurans from diazocompounds

Finally, I would like to share the benzofuran synthesis **3-58** that is using diazocompounds **3-57** as the reagents. Metal-free conditions and Brønsted acid catalysis is used to promote the transformation. In the key step, 1,2-aryl shift is accompanied with dinitrogen elimination. After a ring closure and the dehydration, the authors reported a preparation of 3-substituted benzofurans **3-58** in excellent yields (Scheme 55).¹³⁷

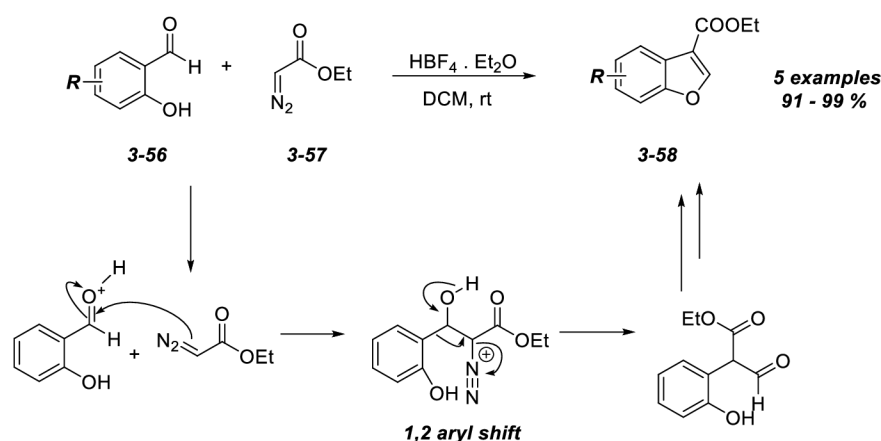

Scheme 55 – Brønsted acid catalysed benzofuran preparation

More common in this context is rhodium catalyzed decarbonylative cyclization, followed by diazo compound **3-60** initiated Rh-carbene formation, that yields desired 2,3-disubstituted benzofurans **3-61**. The key role in this non-coordinating counterion plays $-\text{N}(\text{Tf})_2$ that allows very rapid decarbonylation process, thus formation of

benzofurane **3-58**. On the contrary, when acetate counterion is used, the decarbonylation step is suppressed and the reaction yields chromones (Scheme 56).¹³⁸

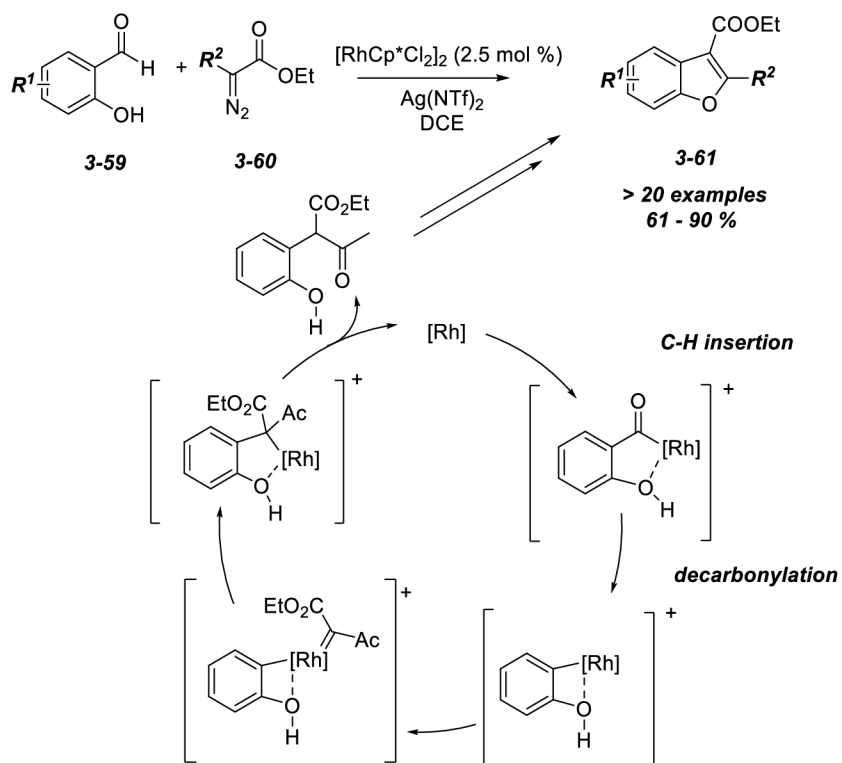

Scheme 56 – Rhodium catalyzed benzofuran preparation

4 Results and discussion

Results achieved during my Thesis can be divided into two parts. In the first one, detailed investigation of the benzothiazole sulfonamide synthesis is discussed, as well as the chemical-physical properties of the obtained products. The second part is then devoted to the biomimetic homocoupling and cross dehydrogenative coupling approach towards (dihydro)benzofuranes.

4.1 Benzothiazolesulfonamides

As briefly mentioned in the theoretical part of the Thesis, there are three main synthetic pathways to sulfonamides. Therefore, this chapter is divided into three parts and each part is devoted to one of the approaches that leads to BT-sulfonamides. In the first part, a detailed discussion that describes the applicability of each approach to BT-sulfonamides synthesis is given. The final part of the chapter then covers the applicability of BT-sulfonamides as a potent synthon for various modifications.

4.1.1 Preparation of sulfonamides from sulfonyl halides

The first main synthetic approach towards sulfonamides uses sulfonyl halides precursor as the key synthetic intermediate (Figure 16). The synthesis of BT-sulfonyl halides, their applications in sulfonamide preparations and the evaluation of scope and limitations of their use is covered in this chapter. We investigated preparations of BT-sulfonyl halides and their applications in sulfonamide preparations, together with evaluation of scope and limitation of such method.

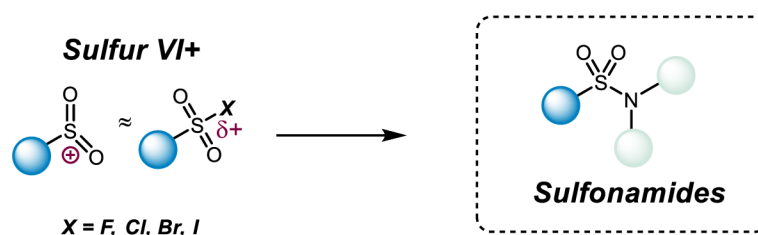

Figure 16 – Sulfonyl halide to sulfonamide transformation

4.1.1.1 Preparation from BT SO_2F

Based on the literature reports, we were aware of the bezothiazole fluoride **4-2** outstanding stability under “normal” conditions.^{43,139} However, the reported BT-sulfonyl fluoride **4-2** synthesis based on the chlorine/fluorine nucleophilic exchange, lacked required convenience and provided BT-sulfonyl fuloride **4-2** in low yields. At this point, we were curious, whether the opposite “electrophilic fluorine” approach would be

successful. From that reasons, we used sulfinic salt **4-1** and reacted it with Selectfluor®. Surprisingly, the reaction proceeded smoothly and yielded the desired BT₂SO₂F **4-2** in short reaction time. During the optimization, strong solvent dependence on reaction yield and the formation of the side products was observed. The highest yield was obtained when the reaction was carried out in MeCN. We also noted a presence of benzothiazole **4-3** in the crude reaction mixture (Table 2). This result was not very surprising, since benzothiazole **4-3** is the natural product of sulfinic salt **4-1** desulfurylation.

Table 2 – BT₂SO₂F synthesis optimization of the reaction conditions

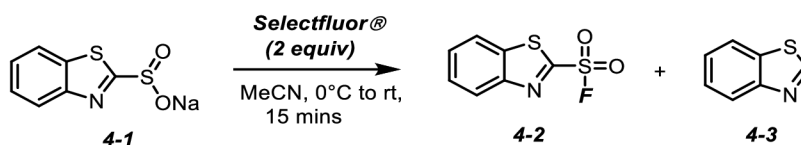

Entry	Solvent	Ratio ^{a)}	Yield(% ^{b)}
1	MeOH	1:2.3	-
2	THF	1:99	-
3	MeCN	99:1	85
4	DCM	99:1	47

a) Based on the crude ¹H NMR spectra; b) refers to isolated yield after the flash column chromatography

Having an easy access to BT₂SO₂F **4-2**, the reaction conditions upon which fluorine atom would be replaced with nitrogen nucleophile were investigated. The reaction that fulfills this requirement is in the literature known as SuFEx protocol. The main advantages of this protocol are described in the chapter 2.3.11 – (Preparation of sulfonamides from sulfonyl fluorides). In a nutshell, the SuFEx protocol could be a very strong weapon in forging S-N bonds starting from sulfonyl fluorides due to selective and high yielding reactions. In our case, we started our optimization reactions with BT₂SO₂F **4-2** and benzylamine **4-5**. After a brief evaluation, we figured out that MeCN is the best reaction solvent, and the reaction provides the sulfonamide **4-6** in best yield, if 3 equivalents of benzylamine **4-5** are used. Higher loading of benzylamine **4-5** had no impact on the reaction yield (Table 3, Entries 1 – 5). Since one equivalent of amine is consumed in the form of HF salt, we speculated if one equivalent of benzylamine **4-5** can be replaced with Et₃N or DABCO. Unfortunately, the use of tertiary amine proved to hamper the reaction and, in such cases, only traces of product **4-6** were obtained. (Table 3, Entries 6 and 8).

This result suggests that DABCO or Et₃N do not behave only as a possible HF scavenging agents, but they also interfere with sulfonamide formation. We speculate that these compounds attacks sulfur atom and substitutes fluorine atom before playing the role of the buffer. Generated DABCO or Et₃N intermediate then might be unstable under the reaction conditions and readily decompose.

Table 3– Optimization of BT sulfonamides preparation

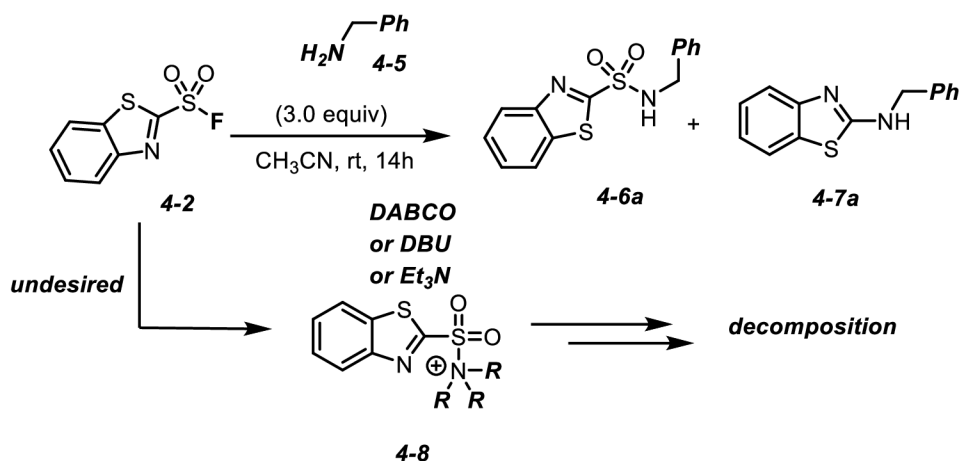

Entry	Conditions	BnNH ₂ (equiv)	Additives	Ratio ^{a)}	Yield ^{b)}	Note
1	MeCN	3	None	>99:1	65	>95% conversion of 4-2
2	MeCN	2	None	15:1	37	>95% conversion of 4-2
3	MeCN	1	None	Traces of 4-6	–	>95% conversion of 4-2
4	MeCN	4	None	>99:1	67	>95% conversion of 4-2
5	MeCN	5	None	>99:1	64	>95% conversion of 4-2
6	MeCN	2	Et ₃ N (2 equiv)	Traces of 4-6	–	>95% conversion of 4-2 , complex mixture
7	DCM	3	None	n.d.	–	>95% conversion of 4-2 , complex mixture
8	MeCN	3	DABCO (2 equiv)	n.d.	–	>95% conversion of 4-2 , complex mixture

^{a)} based on the ¹H NMR spectra of the crude reaction mixture; ^{b)} refers to isolated yield after the flash column chromatography.

Having optimized reaction conditions in hands, we turned our attention to scope and limitations evaluation. The optimized reaction conditions yielded desired BT-sulfonamides **4-6a-d** if primary α -unbranched aliphatic amines were used as

substrates. However, when sterically more demanding amines (α -branched primary and secondary amines) were used, the reaction yields dropped significantly. In the case of anilines, the reaction did not provide products **4-11**, **4-12**, presumably due to low nucleophilicity of nitrogen atom. Another reason behind the low reaction yields, was also the formation of BT-amines **4-7** that are products of competitive attack of amines to electrophilic centre of benzothiazole ring. In such case, after the C-addition, the intermediate **4-9** undergoes desulfurylation to give the undesired BT-amine **4-7**. When cyclohexyl diamine was used as a substrate, a complex mixture of mono/di BT-sulfonamide and mono/di BT-amines were formed **4-6h**, **4-8**, **4-9**.

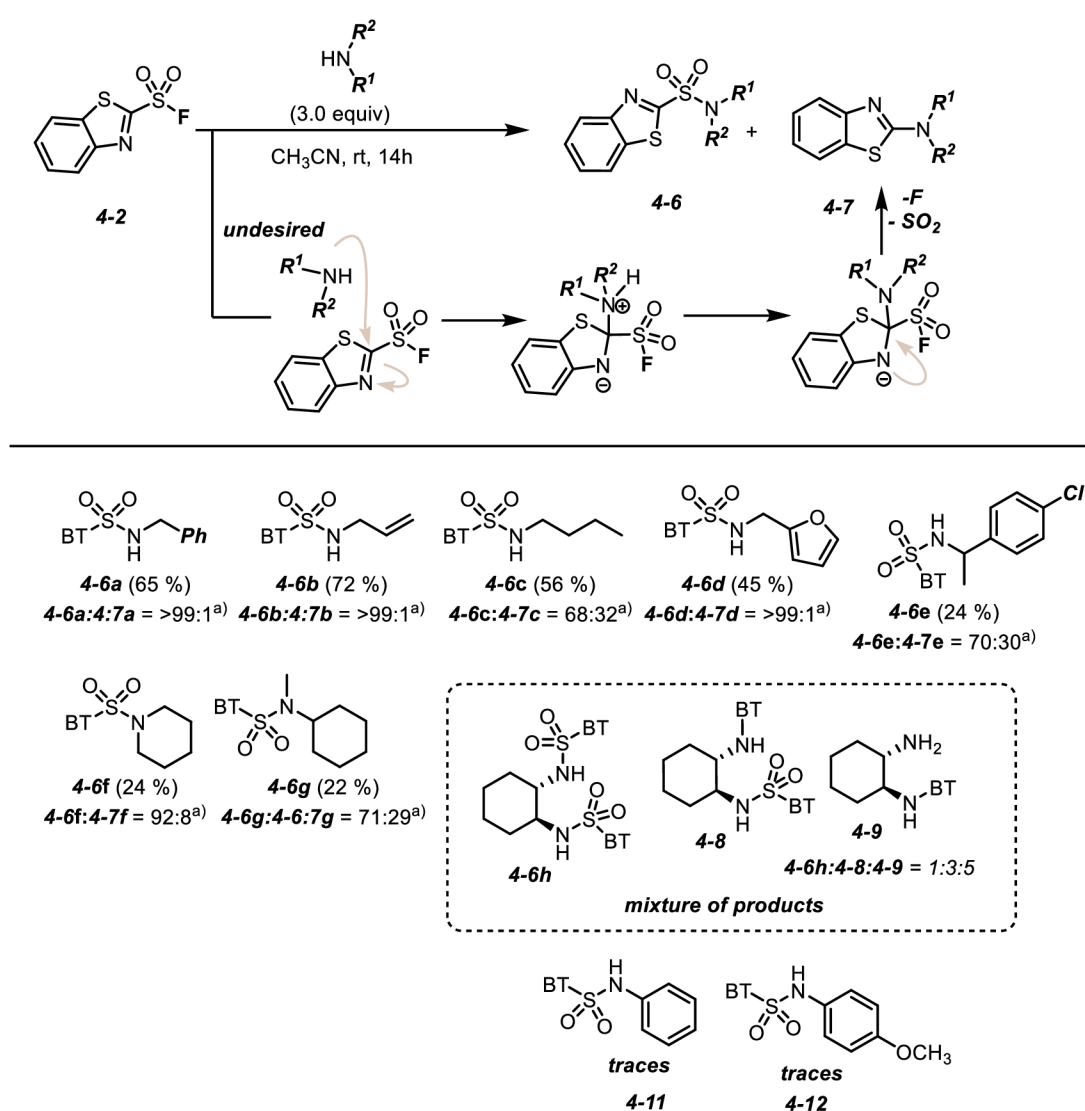

Scheme 57 – Scope and limitation of SuFEx approach

The electrophilic properties of BT-SO₂F **4-2** can be well rationalized with described LUMO map and LUMO orbital energy (1.7 eV) representation (Figure 17). The LUMO

map reveals that the most electrophilic site is located on the benzothiazole ring carbon (blue area).

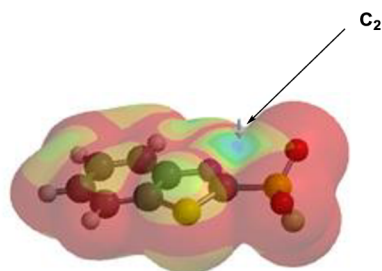
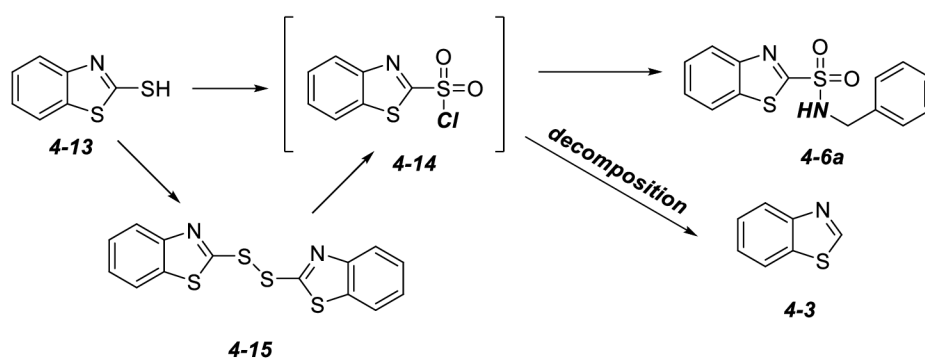

Figure 17 – LUMO map of BTSO₂F - obtained using Spartan Molecular Database, SMD – calculated for equilibrium geometry; DFT ω B97X-D, 6-31G*

Thus, it is understandable that more nucleophilic and more sterically hindered (α -branched primary amines) substrates undergoes undesired attack to C₂ carbon. This phenomenon is the main obstacle behind the limited scope of this reaction. Several optimizations were carried out in order to suppress undesired side reaction; however, change of solvent or the addition of Lewis acids did not shift the reaction outcome to the desired products.

4.1.1.2 Preparation from BT-SO₂Cl

Despite the literature reports claiming that the preparation of BTSO₂Cl **4-14** is rather tricky starting point in BT-sulfonamide preparation **4-6**, we were still keen on reproducing procedures reported in literature. Some of the protocols were based on the use of molecular chlorine in the combination with acetic acid or hydrochloric acid.^{140, 141} Those protocols were not attempted due to safety issues. The other experiments based on the use of bleach or hydrogen peroxide were preferred. In this case, the preparation of sulfonyl chloride **4-14**, followed by its conversion to sulfonamide **4-6a**, yielded the products in very low yields (Table 4). Low yields of these transformations can be attributed to the problematic work up that follows the oxidation. In this case, the reaction mixture as well as all the glassware must be kept at 0 °C. It is expected that most of BTSO₂Cl **4-14** did decompose during this work up procedure. Such observation only discourages our efforts to BT-sulfonamides that would include BTSO₂Cl **4-14** formation.

Table 4– Synthesis of BT-sulfonamides that proceeds via BTSO₂Cl intermediate

Entry	BT-source	Conditions	Isolated yield (%) ^{a)}	Note
1	Disulfide 4-15	1) NaOCl, HCl, DCM, -10 °C, 1 h 2) BnNH ₂ , CH ₂ Cl ₂ , -10°C, 4h	n.d.	No reaction
2	BT-SH 4-13	1) HCl, NaClO, 0°C, CH ₂ Cl ₂ , 1h 2) BnNH ₂ , CH ₂ Cl ₂ , -10°C, 4h	15	
3	BT-SH 4-13	1) (5.0 equiv), HCl, NaClO, 0°C, CH ₂ Cl ₂ , 1h, then -30°C, C ₆ F ₅ OH (3.0 equiv), Et ₃ N (5.0 equiv), CH ₂ Cl ₂ , 5h 2) BnNH ₂ , CH ₂ Cl ₂ , -30°C to 0°C, 1h	48	
4	Disulfide 4-15	BnNH ₂ (1.0 equiv), ZrCl ₄ (1 equiv), H ₂ O ₂ (4 equiv), pyr, rt, 1h	n.d.	Only BT 4-3
5	BT-SH 4-13	BnNH ₂ (1.0 equiv), ZrCl ₄ (1 equiv), H ₂ O ₂ (4 equiv), pyr, rt, 1h	n.d.	Only disulfide 4-15

a) refers to isolated yield after the flash column chromatography

4.1.2 Oxidative coupling method

Next, we turned our attention to oxidative coupling synthesis of sulfonamides using approach where stable sulfur(IV+) derivative is used as the starting material. The oxidation to sulfonyl halides - sulfur(VI+) - in the presence of amine should yield the desired BT-sulfonamides **4-6**. Since the sulfonyl halide is generated in situ, it was expected that this reaction with amine would provide the desired sulfonamides **4-6** without significant undesired decomposition of sulfonylating agent (Figure 18).

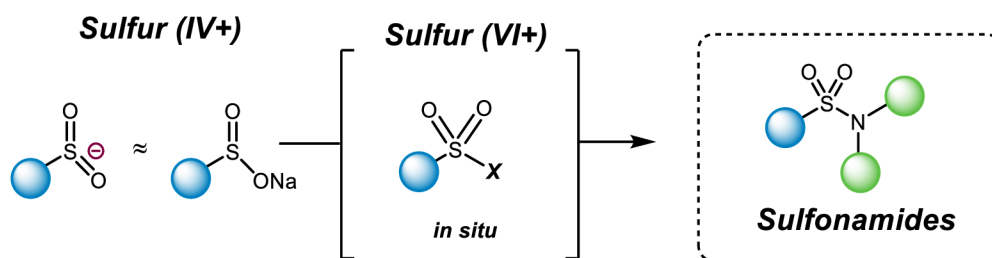
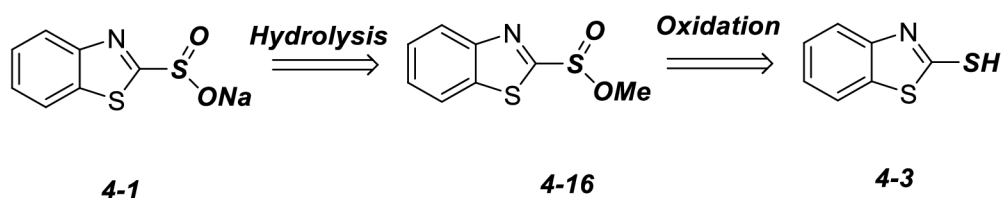

Figure 18 – Oxidative coupling approach to sulfonamides

As mentioned above, the key starting material for the oxidative coupling approach is the BT-sulfinate salt **4-1** (Scheme 58). The salt **4-1** was reported as stable crystalline compound.¹⁴² From the synthetic point of view, 2-mercaptobenzothiazole **4-3** seems to be the most convenient starting material to **4-1**, since it can be readily transformed to **4-1** in two steps via the sulfinic intermediate **4-16** that upon the hydrolysis provides the sodium salt **4-1**.

Scheme 58 – Retrosynthetic approach for BT-SO₂Na preparation

4.1.2.1 Preparation of BT-SO₂Me

The synthesis of sulfinic salt started from the disulfide **4-15** that was transformed to methyl sulfinic ester **4-16** using the Brownbridge protocol.⁹⁰ The reaction provides benzothiazole sulfinic methyl ester **4-16** in high yields (Table 5). During the reaction optimization, we focused on the NBS amount required to achieve the conversion of disulfide **4-15**. It was observed that at least 4 equivalents were needed (Table 5, Entry 3). However, the best results were obtained using 5 equivalents of NBS (Table 5, Entry 2).

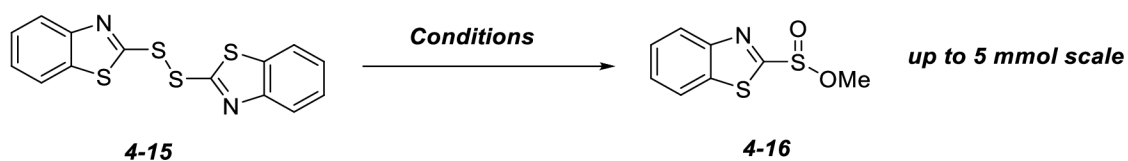
Table 5– Optimization of BTSO₂Me preparation

Entry	BT-source	Br source	Conditions	Isolated yield (%) ^{a)}
1	Disulfide 4-15	NBS (6.0 equiv)	CH ₂ Cl ₂ /MeOH = 1:1 (V/V)	67
2	Disulfide 4-15	NBS (5.0 equiv)	CH ₂ Cl ₂ /MeOH = 1:1 (V/V)	65
3	Disulfide 4-15	NBS (4.0 equiv)	CH ₂ Cl ₂ /MeOH = 1:1 (V/V)	60
4	Disulfide 4-15	NBS (3.5 equiv)	CH ₂ Cl ₂ /MeOH = 1:1 (V/V)	55
5	Disulfide 4-15	NBS (3.0 equiv)	CH ₂ Cl ₂ /MeOH = 1:1 (V/V)	51
6	Disulfide 4-15	NBS (2.5 equiv)	CH ₂ Cl ₂ /MeOH = 1:1 (V/V)	32
7	Disulfide 4-15	NBS (2.0 equiv)	CH ₂ Cl ₂ /MeOH = 1:1 (V/V)	20
8	Disulfide 4-15	NBS (1.0 equiv)	CH ₂ Cl ₂ /MeOH = 1:1 (V/V)	0
9	Disulfide 4-15	Br ₂ (5.0 equiv)	CH ₂ Cl ₂ /MeOH = 1:1 (V/V)	66
10	Disulfide 4-15	Br ₂ (4.0 equiv)	CH ₂ Cl ₂ /MeOH = 1:1 (V/V)	62
11	BT-SH 4-3	NBS (2.5 equiv)	CH ₂ Cl ₂ /MeOH = 1:1 (V/V)	71
12	BT-SH 4-3	Br ₂ (2.5 equiv)	CH ₂ Cl ₂ /MeOH = 1:1 (V/V)	70

a) refers to isolated yield after the flash column chromatography

Next, the hydrolysis of methylsulfinyl disulfide **4-15** was performed using standard reaction conditions and sodium sulfinate **4-1** was obtained in good yields (Scheme 59). The salt **4-1** is therefore stable and can be stored at room temperature for prolonged period

of time. The great advantage of the use of sulfinic salt **4-1** as the starting material is its thermal stability that allows its storage for decent period of time. The only drawback of **4-1** is its lability to acids that results in desulfurylation reaction that yields benzothiazole **4-3**. This synthetic disadvantage is however viewed as an advantage if this salt **4-1** is used in physiological systems. Indeed, H^+ - labile properties of **4-1** were studied intensively and the salt **4-1** was used as SO_2 - releasing substrate in the context of SO_2 regulation of mammalian pulmanary systems. The half-life of sodium benzothiazole **4-1** sulfinate at pH 4 and 5 ($37^\circ C$) is 7.5 and 75 min, respectively.¹⁴²

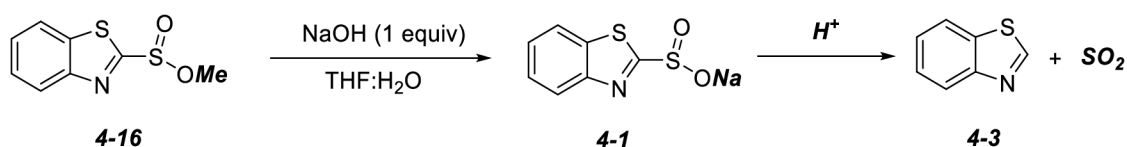

Scheme 59 – Sodium sulfinate preparation

Mechanistic investigation of the methyl sulfinate formation

Let's turn our attention back to the methyl BT-sulfinate **4-1** synthesis. Since the original paper does not discuss the reaction mechanism, we were intrigued in detailed reaction mechanism investigation.⁹⁰ It was obvious that the oxidizing agent is "Br⁺" species derived from NBS or Br₂. Due to red/brown colour (*vide infra*) of the reaction mixture, Br₂ was considered as the oxidant. Indeed, bromine might activate disulfidic bond towards nucleophilic attack of methanol (Scheme 60). Such transformation would lead to one equivalent of methyl sulfenester **4-18** and one equivalent of sulfenylbromide **4-19** that rapidly undergoes reaction with methanol. Resulting HBr then regenerates Br₂ from the molecule of NBS.

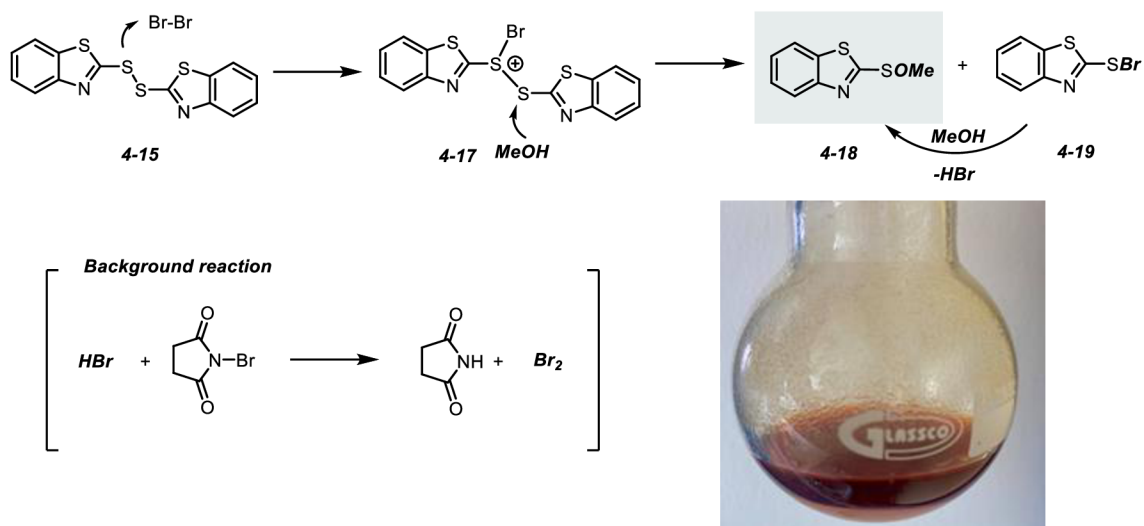

Scheme 60 – Expected reaction mechanism of BTSOMe generation

Having generated methyl sulfenate **4-18**, it is further oxidized by Br_2 to sulfinic ester **4-16**. There are two possible reaction pathways that can accomplish this transformation. In both cases, first electrophilic addition of “ Br^+ ” species to sulfur of methylsulfenate **4-18** occurs (Scheme 61). Generated oxonium-like intermediate **4-20** then can (A) undergo the addition of MeOH to yield tetrahedral intermediate **4-21**, that upon the elimination of MeBr yield the sulfinic ester **4-16**. Or (B) can undergo “ Br^- ” mediated demethylation to yield **4-22**, via BTSOBr **4-22** intermediate to the desired methylsulfinate **4-16**. The resulting MeBr alkylates methanol that leads to HBr and Br_2 regeneration.

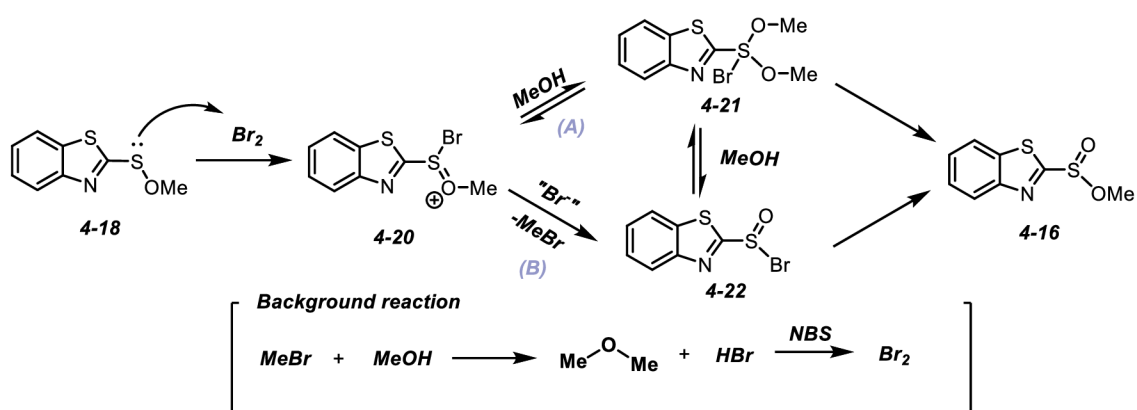
Scheme 61 – Proposed mechanism of BTSO₂Me preparation (Part 2)

To shed more light on this transformation, the formation of the methylsulfenate **4-18** key intermediate was investigated. From that reason, stable phenylsulfenate **4-25** was independently prepared and characterized starting from thiophenol **4-23** (Scheme 62). The methylsulfenate **4-25** was then treated with NBS in methanol to mimic the reaction

conditions we used during the BT-methyl sulfinate **4-16** synthesis. The reaction sequence using reported reaction yielded sulfinic ester **4-26** in good yield and purity.^{198,199}

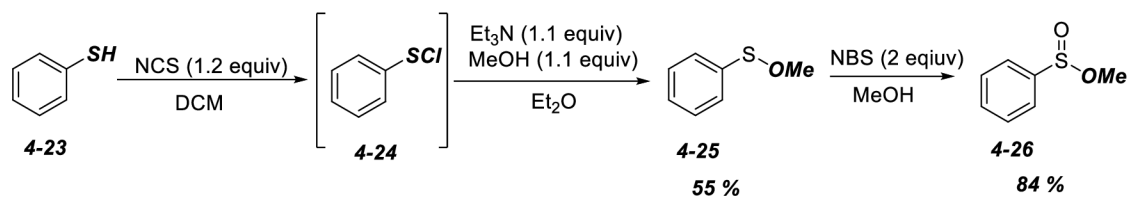

Scheme 62 – PhSO₂Me synthesis

4.1.2.2 Sulfonamide synthesis

The oxidative coupling approach was inspired by the work reported by Yan et al.⁷¹ and the recent report from by Xian.¹⁴³ This synthetic protocols describes the use of *m*CPBA/TBAB as Br₂ source to achieve sulfonamides **4-29**. The reaction proceeds the same reaction pathway as shown in the theoretical part of the Thesis (Scheme 63).

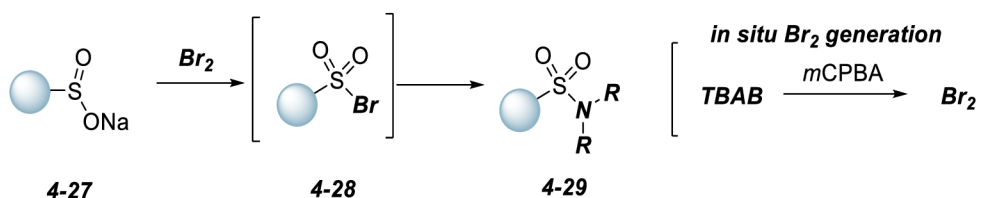

Scheme 63 – General scheme of sulfonamide synthesis based on the oxidative coupling protocol

To start, the protocol of Xian¹⁴³ was examined and the desired sulfonamide **4-6a** was isolated in 77 % yield. However, this protocol (*m*CPBA/TBAB) uses several different components that does not fulfill our atom-efficiency requirement. We attempted to optimize/simplify the reaction conditions on the model reaction of sulfinic salt **4-1** and benzylamine. We observed that eventhough the conversion of the sulfinic salt **4-1** is quantitative, the reaction yields also benzothiazole **4-3**. The formation of benzothiazole **4-3** is the result of a competitive nucleophilic attack of amine to the bromine atom. To avoid this undesired side reaction and to increase the yields, we vary the source of bromine, oxidizing agents, base, and solvent.

Soon we figured out that the role of bromine source and the presence of *m*-chlorobenzoic acid (from *m*CPBA) are the crucial agents that have an impact on the reaction progress. It was shown that the presence of *m*-chlorobenzoic acid is causing the sulfinic salt **4-1** decomposition. Thus, Br₂ was added as “Br⁺” source, to promote the reaction (Table 6, Entry 4). The reaction yields the sulfonamide **4-6a** and only traces of **4-3** was observed. The disadvantage of this approach, however, was the problematic quantification of the

Br₂ when the reactions were carried out in small scale. Thus, we searched for Br₂ alternative that we found in the NBS. The use of NBS did solve the important issues that was the Br⁺ source and also H⁺ scavenger. Using NBS in THF/EtOH (4:1) the desired sulfonamide **4-6a** was isolated in 91 % yield (Table 6, Entry 6). The same result was achieved if the reaction was carried out at 0 °C (Table 6, Entry 8), however if -78 °C was the temperature of the reaction mixture, only the product of sulfinic salt **4-1** desulfurylation **4-3** was isolated (Table 6, Entry 9). If the reaction was carried out in THF/EtOH solvent mixture (Table 6, Entry 7) or in the presence of higher NBS loading (Table 6, Entry 10), the higher amount of undesired product **4-3** was formed. The higher loading of the benzylamine (Table 6, Entry 12) seemed to have a little impact on the reaction outcome. The use of alternative X⁺ sources as NCS, NIS or I₂ led only to the decomposition of the sulfinic salt **4-1** (Table 6, Entries 13-15).

Table 6 – Optimization of BT-sulfonamides preparation

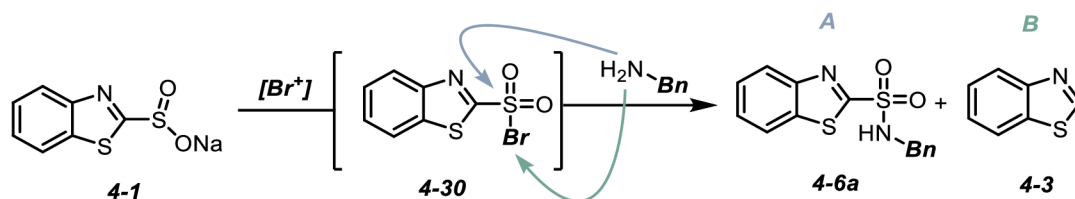

Entry	Reaction conditions	A/B ratio	Isolated yield (%) ^{a)}	Sulfinic salt conversion ^{b)}
1	BnNH ₂ (1.2 equiv), DIPEA (1.5 equiv), TBAB (1.5 equiv), mCPBA (3 equiv), THF:EtOH (1:1), rt lit. ⁷¹	5.6:1	77	>95%
2	BnNH ₂ (1.2 equiv), DIPEA (1.5 equiv), KBr (1.5 equiv), mCPBA (3 equiv), THF:EtOH (1:1), rt	1.6:1	53	>95%
3	BnNH ₂ (1.2 equiv), DIPEA (1.5 equiv), KBr (1.5 equiv), H ₂ O ₂ (3 equiv), THF:EtOH (1:1), rt	1:99	–	>95%
4	BnNH ₂ (1.2 equiv), DIPEA (1.5 equiv), Br ₂ (2 equiv) THF:EtOH (1:1), rt	11.5:1	86	>95%
5	BnNH ₂ (1.2 equiv), NBS (1.5 equiv), THF:EtOH (1:1), rt	4:1	77	>95%

6	BnNH ₂ (1.2 equiv), NBS (1.5 equiv) THF:EtOH (4:1), rt	13:1	91	>95%
7	BnNH ₂ (1.2 equiv), NBS (1.5 equiv) THF:EtOH (20:1), rt	4.2:1	–	>95%
8	BnNH ₂ (1.2 equiv), NBS (1.5 equiv) THF:EtOH (4:1), 0 °C	12:1	90	>95%
9	BnNH ₂ (1.2 equiv), NBS (1.5 equiv) THF:EtOH (4:1), -78 °C	1:99	–	>95%
10	BnNH ₂ (1.2 equiv), NBS (2 equiv) THF:EtOH (4:1), rt	7.3:1	–	>95%
11	BnNH ₂ (1.2 equiv), NBS (3 equiv) THF:EtOH (4:1), rt	9:1	–	>95%
12	BnNH ₂ (2 equiv), NBS (1.5 equiv) THF:EtOH (4:1), rt	10:1	–	>95%
13	BnNH ₂ (1.2 equiv), NCS (3 equiv) THF:EtOH (4:1), rt	1:99	–	>95%
14	BnNH ₂ (1.2 equiv), NIS (3 equiv) THF:EtOH (4:1), rt	1:99	–	>95%
15	BnNH ₂ (1.2 equiv), I ₂ (3 equiv) THF:EtOH (4:1), rt	1:99	–	>95%

a) refers to pure isolated compound after the flash column chromatography; b) refers to conversion of sulfinic salt based on ¹H NMR

Having established suitable reaction conditions for the oxidative coupling between sulfinic salt **4-1** and amine, the scope and limitations of the method were evaluated. Primary and secondary aliphatic amines were suitable substrates for targeted transformation and yielded the sulfonamides **4-6a**, **4-6c** in good to excellent yields. In this context, it was observed that the reaction conditions tolerate carbonyl group **4-6i**, unsaturated bonds **4-6b** and aromatic rings **4-6e**, **4-6j**. Furthermore, when aminoalcohols were used as the starting material, the method proved to be chemoselective and yielded only sulfonamides **4-6k**, **4-6l**. The method is also readily scalable (5 mmol) without any drop in reaction yields. On the other hand, the reaction conditions were not applicable if anilines **4-31**, **4-32**, **4-36**, **4-37**, **4-38** were reacted. Observed unreactivity can be attributed to low aniline nitrogen lone pair nucleophilicity. In addition, when anilines **4-31**, **4-32**, **4-36**, **4-37**, **4-38** were used as the starting material, and also in case of furan-base

amine **4-39**, the only product of aromatic ring bromination was observed. When NH_4Cl **4-50**, aminoacids derivatives, or NH_2CN **4-49** were used as the starting material, the reactions failed to provide desired products (Table 7).

Table 7- Scope and limitations of oxidative coupling approach

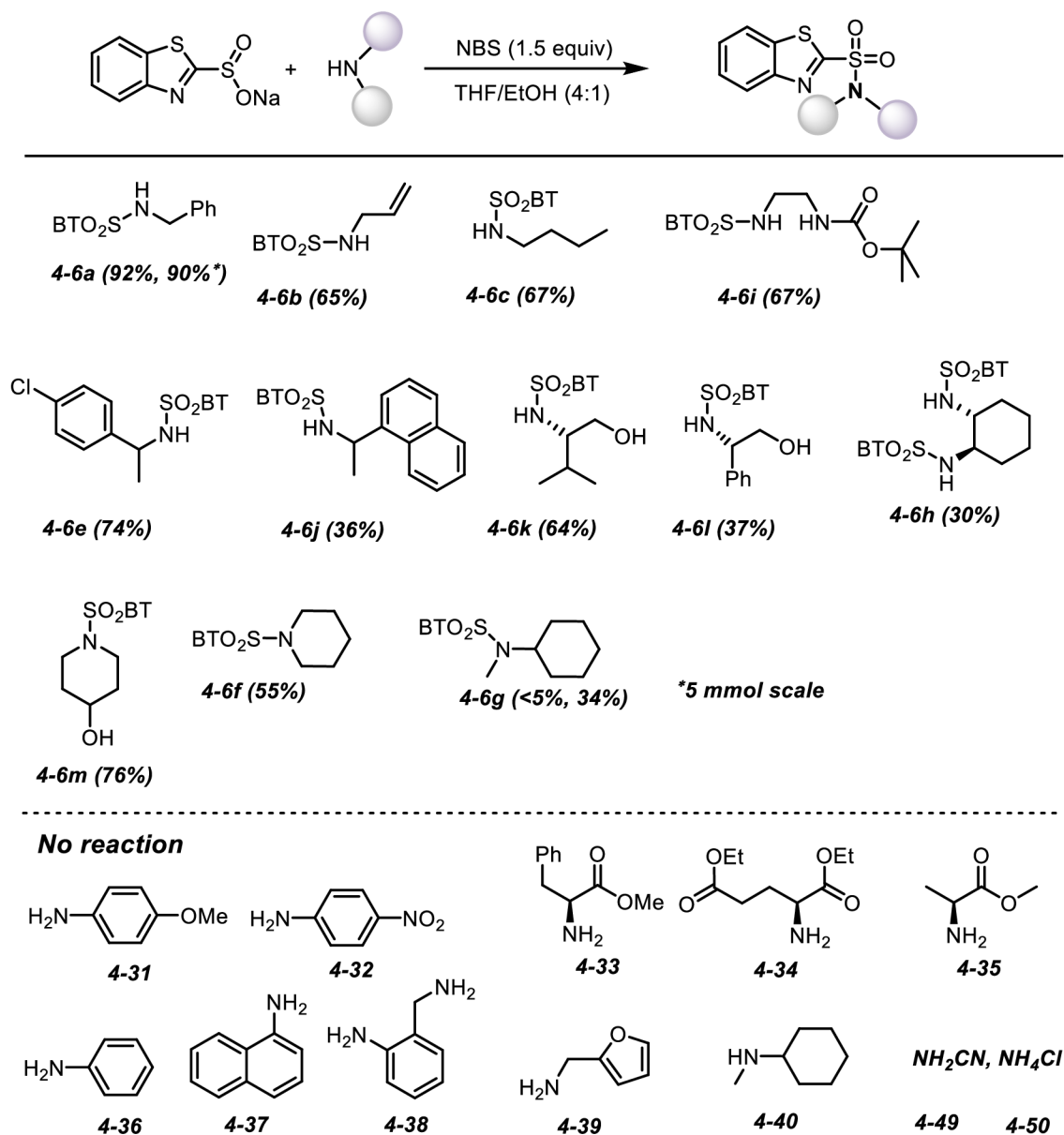

Mechanistic investigation

Now I would like to go back to the reaction mechanism of oxidative coupling reaction. During the optimization of the reaction conditions, we observed that the reaction is nearly instantaneous. It usually took only few seconds to its full completion. Presumably, the reaction is one of the examples of diffusion controlled. When we carried out the reaction

in the presence of radical scavenger (TEMPO), no significant change in the reaction rate or yields was observed. Interestingly, the reaction is carried out in EtOH, as the nucleophilic co-solvent. Surprisingly, no ethyl sulfonate was observed during or after the reaction in the crude reaction mixture. The N over O selectivity can be rationalized by higher nucleophilicity of nitrogen atom over oxygen.

Having in hands these results, we can speculate over the three possible reaction pathways (Scheme 64). First **Pathway A** was considered. In this case BT SO_2Br **4-30** should be formed as the intermediate and we believe that it is rather unlikely that no ethylsulfonate would be formed if the reaction proceeds via this intermediate. In case of **Pathway B**, N-bromo intermediate **4-42** is formed, and that might answer the question, why no ethyl sulfonate and only BT-sulfonamide **4-6** formation was observed. Third radical reaction (**Pathway C**) can be ruled out, because the reaction proceeds in the presence of radical scavenger. However, no reaction pathway can be explicitly ruled out, and the mechanism can differ from substrate to substrate.

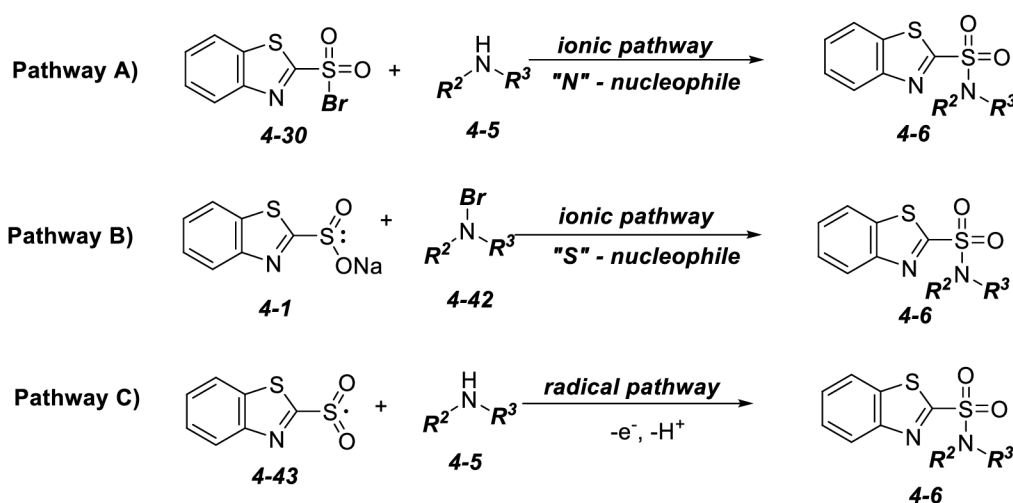

Scheme 64 – Possible mechanistic pathways of oxidative coupling

4.1.3 BT-sulfonamide synthesis via S-N coupling followed by oxidation

Having obtained the first two, although limited approaches to sulfonamides **4-6**, the third possible way based on the S-N bond forming/oxidation approach was investigated (Scheme 65). Since the sequence consist of two steps, both of them will be discussed separately.

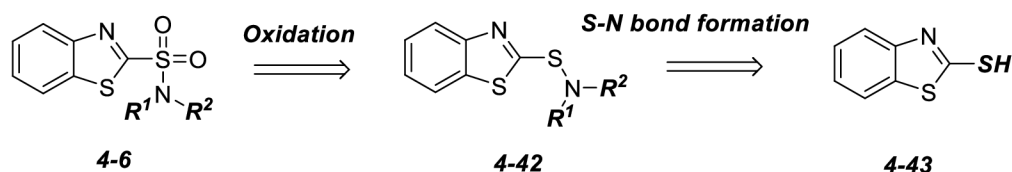

Scheme 65 – Two step approach to BT sulfonamides starting from benzothiazol

4.1.3.1 S-N bond formation

The BT-sulfenamide **4-42** synthesis was first described by Brownbridge et al.¹⁴⁴ who reported reaction of 2-mercaptobenzothiazole **4-43** and amines in the presence of NCS. The depicted reaction proceeded smoothly and provided sulfenamides **4-42** in good yields and purity. Interestingly, in this transformation, minimum 3 equivalents of amines were required to draw the reaction to its completion (Scheme 66).

Brownbridge conditions

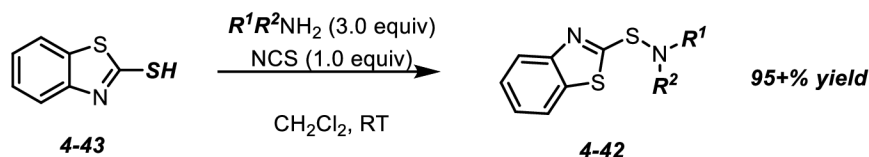

Scheme 66 – Sulfenamide preparation starting from 2-mercaptobenzothiazole and benzylamine

Since, the Brownbridge protocol was missing any details about the transformation; we decided to investigate the reaction in more details. First, upon mixing of 2-mercaptobenzothiazole **4-43** and amine, the formation of white suspension was observed. Such observation suggested rapid formation of ammonium salt **4-44**. Without NCS addition, no reaction occurred, however, after the addition of NCS the reaction started immediately. The reaction mixture relatively fast underwent the change from suspension to clear solution. Observation that suggested consumption of presumed ammonium salt **4-44** intermediate. Over the time, white precipitate again started to form in the reaction mixture. This salt was further identified as BnNH_3Cl and after the given reaction time **4-45** was isolated in nearly quantitative yield. Next, we turned our attention towards benzothiazole disulfide **4-15** since its formation was detected when anilines were used as the starting substrates. The question was: at which point of the reaction is this compound formed? Mainly, we were wondering if the formation of disulfide **4-15** is an undesired side reaction, or if it is sort of “resting state” intermediate that can be successfully transformed into the desired sulfenamide **4-45**. To make the situation even more complex, in the case of the reaction with aniline, some BTSH **4-43** (presumably in form of its salt - $\text{BnNH}_3\text{BTS}^-$ **4-44**) was also present in the reaction mixture. To address

this, the reaction of the disulfide **4-15** and benzylamine **4-5a** without any other additive was carried out. To our surprise, the product sulfenamide **4-45** was formed, albeit in considerably lower yield (Scheme 67, Eq 2). When the same reaction was performed, together with an addition of NCS (1 equiv), the product **4-45** was isolated in 91 % yield (Scheme 67, Eq 3). To evaluate, whether the radical pathway is not operating, the experiment was performed in the presence of TEMPO (Scheme 67, Eq 6). In this case, no significant drop in yield was observed, that led us to discard such possibility.

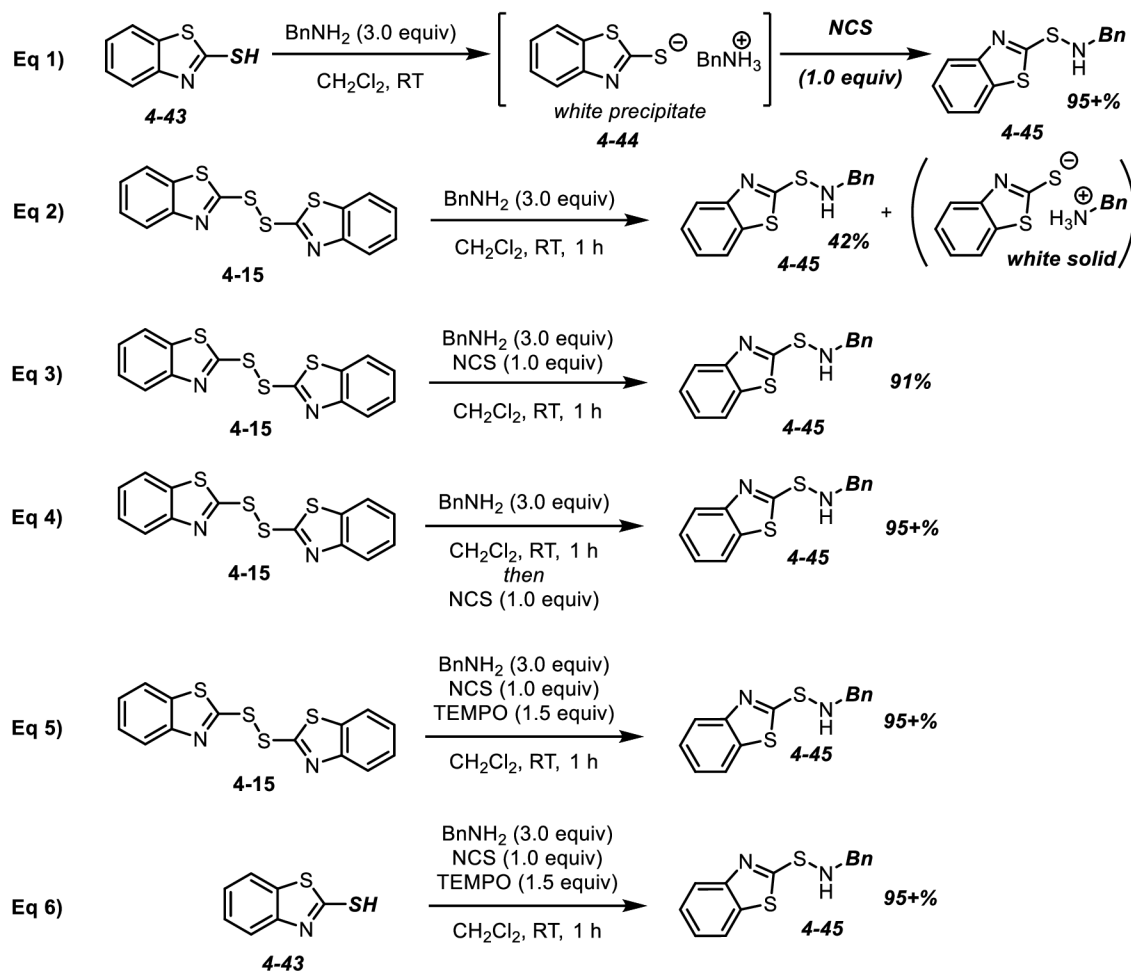

Scheme 67 – Control experiments that should shed more light in to the mechanism of sulfenamide formation

Based on those experiments, two possible pathways that may occur during the sulfenamide formation **4-45** were postulated (Scheme 68). The first pathway (**Pathway A**) suggested the reaction proceeds via sulfenyl chloride **4-45** intermediate, that undergoes the nucleophilic displacement with amine and, upon the deprotonation, yields the desired sulfenamide **4-47**. The second possibility (**Pathway B**) thus seems to operate in case of less nucleophilic or more sterically hindered amines. We believe that the lower reactivity of amine then favorize the addition of BTS^- **4-44** or BTSH **4-43** to BT-S-Cl

4-45 and gives the disulfide **4-15**. The disulfide **4-15** then reacts with additional equivalent of BTSH **4-43** and yields the sulfenamide **4-47**.

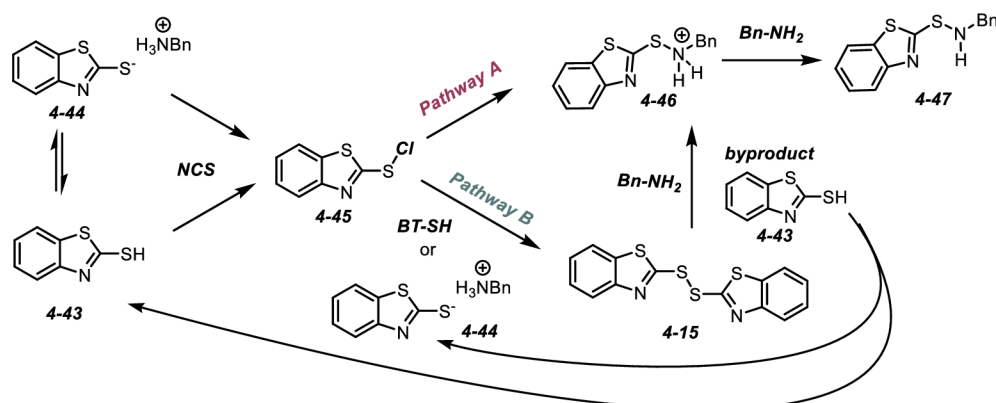

Scheme 68 – Plausible mechanism of sulfenamides formation

Our findings then suggest that only 2 equivalents of amine should be required to reach the maximal reaction yield. However, we presume that considerable amount of BTSH **4-43** is “trapped” in the form of ammonium salt **4-44** that results in lower concentration of free amine in the solution. Such lower concentration presumably decreases the ability to promote the reaction to full conversion. From that reasons, 3 equivalents of amine were used and proved to be optimal amount.

4.1.3.2 Sulfenamide oxidation

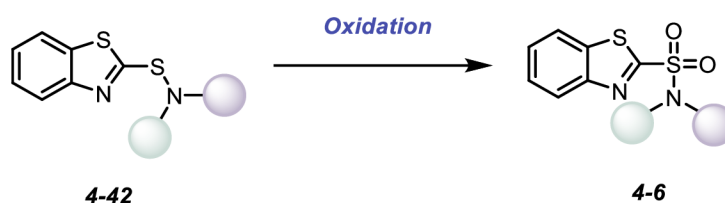

Scheme 69 – Sulfenamide oxidation

Based on the literature reports,^{145,146} the oxidation process of sulfenamides **4-42** to sulfonamides **4-6** is rarely employed in synthetic and medicinal chemistry. The main reason behind is the fact that this oxidation usually proceeds in very low yields. That can be in case of heteroaryl sulfenamides even labelled as “lausy”. Thus we decided to find new oxidation conditions that would be able to oxidize sulfur(II) atom from sulfenamide **4-42** to sulfur(VI) of sulfonamide **4-6**. At the same time, the conditions should have large functional group tolerance. First, we aimed to evaluate the influence of the “classic” oxidation conditions such as KMnO_4 or *m*CPBA for transformation of sulfenamide **4-47** to **4-6a** (Table 8, Entry 1, Entry 2). Unfortunately, only traces of product **4-6a** along with

4-3 were detected. Next, oxidation using $\text{H}_5\text{IO}_6/\text{CrO}_3$ that has been successfully used in our group for oxidation of sulfides to sulfones was adopted (Table 8, Entry 3).^{1,2} In this case the product **4-6a** was formed, however, its stability under the reaction conditions was low and its degradation was observed. Next, $\text{KMnO}_4/\text{CuSO}_4$ oxidation system⁹⁷ was attempted to promote the reaction (Table 8, Entry 4). In this case, the desired product **4-6a** could be isolated in 23 % yield. More importantly, the formation of the side product **4-3** was negligible under such reaction conditions. Based on our previous experience in heteroaryl sulfides to sulfone oxidation¹⁴⁸ the Mo-based oxidation was attempted. Gratifyingly, the desired product **4-6a** was obtained in 89 % yield (Table 8, Entry 5).

Table 8– Optimization of sulfenamide oxidation

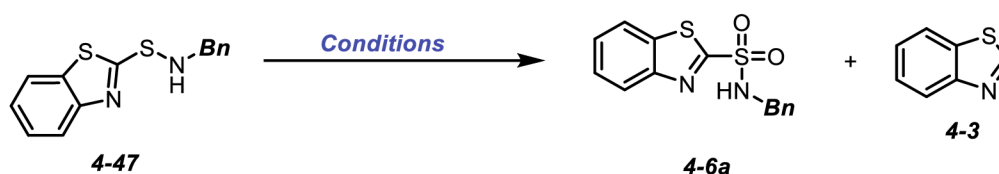

Entry	Reaction Conditions	3a/S15 ratio ^a	Isolated yield (%) ^b	Note
1	mCPBA (77%, 2.1 equiv), CH_2Cl_2 , 0°C, 24h	1.6:1	-	>95% conversion of 4-47 ^a
2	KMnO_4 (5 equiv), acetone, 0 °C, 24h	1:5	-	>95% conversion of 4-47 ^a
3	H_5IO_6 , CrO_3 , MeCN, 0°C, 6h	1:99	-	>95% conversion of 4-47 ^a
4	KMnO_4 : $\text{CuSO}_4 \cdot 5\text{H}_2\text{O}$ (1:1.5), rt, overnight	99:1	23	>95% conversion of 4-47 ^a several unidentified side products
5	H_2O_2 , $(\text{NH}_4)_6\text{MoO}_4 \cdot 4\text{H}_2\text{O}$ (0.3 equiv), 0°C	99:1	89	>95% conversion of 4-47 ^a

a) based on the ^1H NMR spectra of the crude reaction mixture; b) refers to isolated yield after the flash column chromatography.

Having optimized reaction conditions, the scope and limitations of the BT-SH **4-43** to BT-sulfonamides **4-6** transformation was evaluated. Using our two-step protocol, various sulfonamides **4-6** were prepared in good to very good yield (Table 9). The first step

provide sulfenamides **4-42** in sufficient purity to be directly transformed to the desired sulfonamides **4-6** without further purification. The second step is then usually “the troublemaker” step since oxidation conditions are not always compatible with sulfenamide **4-42** and/or sulfonamide **4-6** stability. In short, primary alkyl amines, α -branched alkylamines and secondary *N,N*-dialkylamines proved to be suitable substrates for the two step transformation and yielded BT-sulfonamides **4-6a**, **4-6b**, **4-6c**, **4-6g**. On the other hand, α -branched benzylamines **4-6j**, **4-6e**, anilines, and NH_4Cl **4-50** or NH_2CN **4-49** proved to be incompatible with the reaction conditions. The real power of this method is in the possibility of using aminoacids as starting material without any loss of the stereointegrity. Even, HCl-salts of aminoacid esters could be used as a starting material when modified procedure Et_3N was added for preparation of **4-6n**, **4-6o**, **4-6p**. The protocol is also readily scalable (up to 10 mmol) without any significant drop in reaction yield.

Table 9– Scope and limitations of the 4-43 to 4-6 synthesis

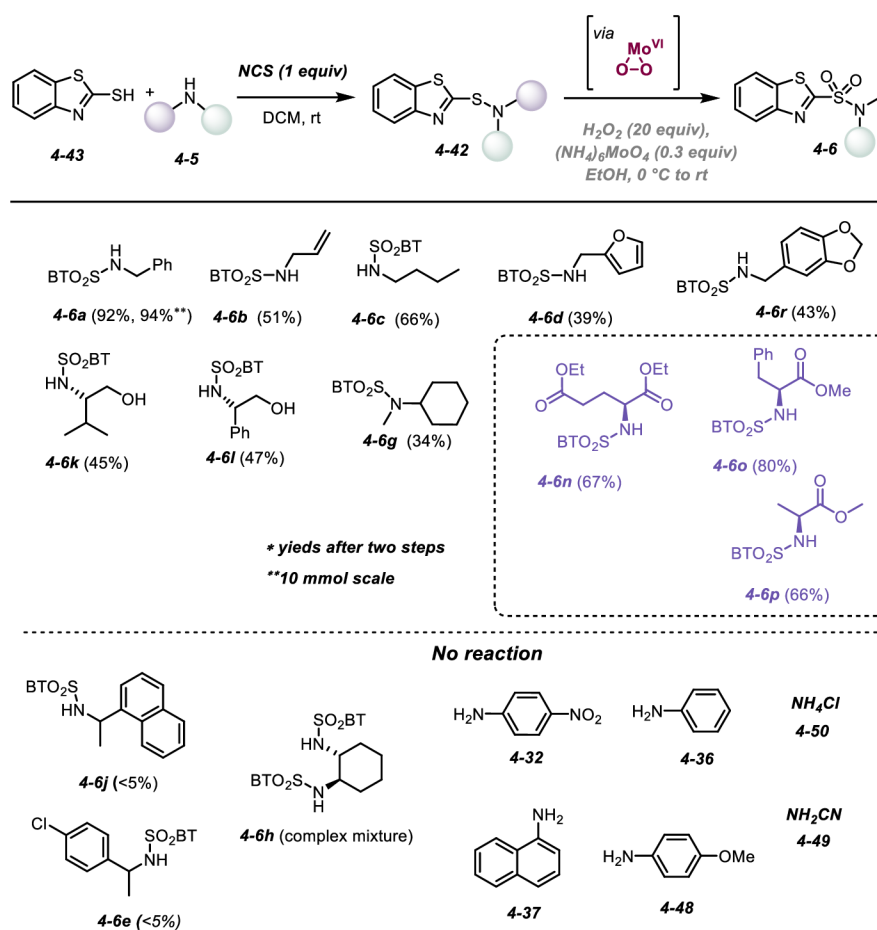

a) All reported reaction yields refer to pure isolated compounds over two steps b) reactions carried out in 10 mmol scale

4.2 Properties of BT-sulfonamides

4.2.1 pK_a of BT sulfonamides

Having in hands short and efficient way to BT-sulfonamides **4-6** we have decided to investigate the properties of obtained compounds. Especially we were interested in the evaluation of the N-H bond properties – pK_a(SO₂NHR) values. Our interest in this bond was based on our previous experience with BT-sulfones.^{1,2} That allowed us to explore and efficiently exploit relatively high BT-SO₂CHR¹R² acidity in context of synthetic method development. To evaluate the pK_a values of prepared sulfonamides, the potentiometric measurements in H₂O and later on in EtOH (to solve the solubility issues) was performed. These measurements provided very interesting results, since the pK_a values were lower than expected. Regarding the measurements in water solution, the pK_a value for compound **4-6a** was 3.34. The value is more than 1.5 lower than AcOH (pK_a = 4.75). Due to a solubility issues, further pK_a values determination were performed in EtOH. However, even in these cases, the sulfonamidic hydrogen atoms had pK_a values similar to carboxylic acids.¹⁴⁹ Such expected acidity of BT-sulfonamides of course triggered interest in its exploration in organic synthetic method development (Figure 19).

Figure 19 – pK_a values of several BT-sulfonamides

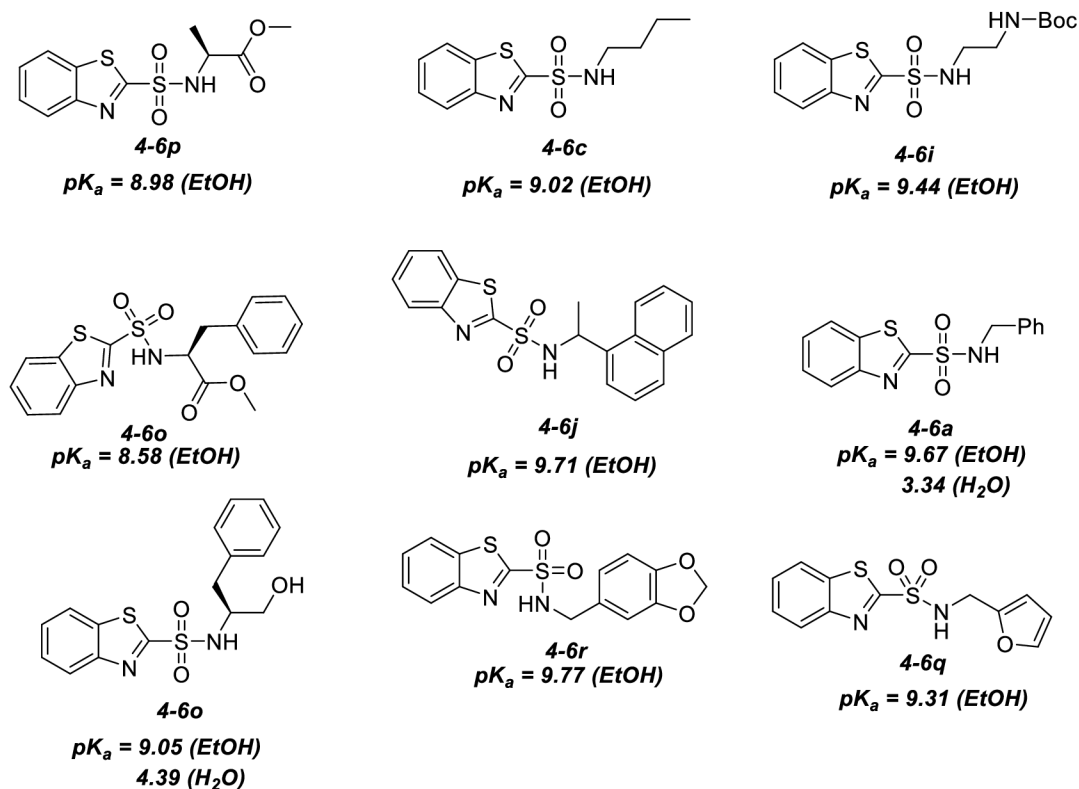

4.3 Further modification of sulfonamides

4.3.1 Alkylation of BT sulfonamides

To explore the observed N-H acidity of sulfonamides **4-6**, we focused our attention to simple alkylation and Fukuyama-Mitsunobu reactions. Eventhough, the development of both concepts proceeded simultaneously, I will first discuss Fukuyama-Mitsunobu alkylation (Scheme 70).

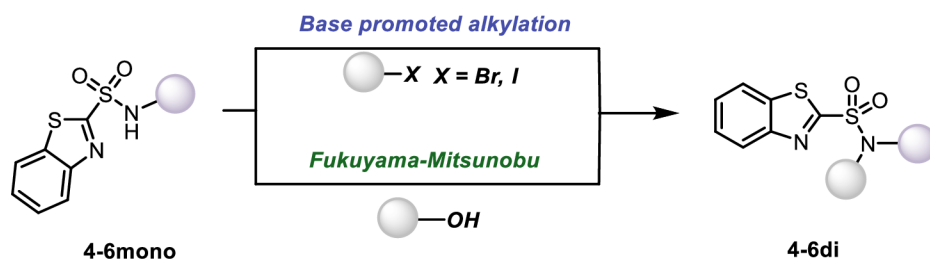

Scheme 70 – BT sulfonamide alkylations

4.3.1.1 Mitsunobu reaction

After several screening experiments using classical Mitsunobu protocol (Table 10, Entries 1-8) *N,N*-dialkylated sulfonamides **4-6** were obtained only in traces. Variety of different, less common azocompounds and phosphines were evaluated under various conditions but still no products **4-6** were obtained (not shown). Finally, we switched to microwave conditions and we observed full conversion of sulfonamide **4-6a** and isolated desired product **4-6aa** in 84 % yield in 10 minutes (Table 10, Entry 9). Again, rather unexpected behaviour of sulfonamide **4-6** than expected was observed. After slight optimization it was observed that the full sulfonamide **4-6a** conversion proceeded at 50 °C in just 10 minutes in the presence of DIAD (1.5 equiv), Ph₃P (1.5. equiv) and alcohol (1 equiv) (Table 10, Entry 12). Interestingly, when the reaction was attempted using standard heating technique (oil bath) no reaction was observed (no product formation and no conversion of sulfonamides). Observed behaviour was well rationalized using the hot-spots paradigm.¹⁵⁰ Our extensive literature research further revealed few literature reports that referred to the use of microwave irradiation in promoting the Mitsunobu alkylations.^{151–153}

Table 10 – Fukuyama-Mitsunobu alkylation reaction optimization

Entry	Reaction Conditions	Yield (%) ^b	Note
1	4-6a (1 equiv), DEAD (1.5 equiv), Ph ₃ P (1.5 equiv), EtOH (2 equiv), THF	-	No reaction
2	4-6a (1 equiv), DEAD (1.5 equiv), Ph ₃ P 1.5 equiv, BnOH (2 equiv), THF	-	No reaction
3	4-6a (1 equiv), DEAD (3 equiv), Ph ₃ P (3 equiv), BnOH (1 equiv), THF	-	No reaction
4	4-6a (1 equiv), DIAD (3 equiv), Ph ₃ P (3 equiv), BnOH (1 equiv), THF	-	No reaction
5	4-6a (1 equiv), DEAD (3 equiv), Bu ₃ P (3 equiv), MeOH (1 equiv), THF	>60%	conversion
6	4-6a (1 equiv), ADMP (3 equiv), Bu ₃ P (3 equiv), MeOH (1 equiv), THF	>55%	conversion
7	4-6a (1 equiv), DEAD (3 equiv), Bu ₃ P (3 equiv), 3-hydroxy-2-methyl-1-propene (1.5 equiv), MeOH (1 equiv), THF	-	No reaction
8	4-6a (1 equiv), DEAD (3 equiv), Bu ₃ P (3 equiv), 3-hydroxy-2-methyl-1-propene (1.5 equiv), MeOH (1 equiv), toluene	-	No reaction
9	4-6a (1 equiv), DIAD (3 equiv), Bu ₃ P (3 equiv), PrOH (1.5 equiv), THF, μ W = 150W, 100 °C, 10 min	84	>95% conversion of 4-6a
10	4-6a (1 equiv), DIAD (3 equiv), Ph ₃ P (3 equiv), BnOH (1.5 equiv), THF, μ W = 100W, 50 °C, 10 min	74	>95% conversion of 4-6a
11	4-6a (1 equiv), DIAD (3 equiv), Ph ₃ P (3 equiv), BnOH (1.5 equiv), THF, 50 °C, 1 h	-	No reaction
12	4-6a (1 equiv), DIAD (1.5 equiv), Ph ₃ P (1.5 equiv), BnOH (1.5 equiv), THF, μ W = 100W, 50 °C, 10 min	88	>95% conversion of 4-6a
13	4-6a (1 equiv), DIAD (1.5 equiv), Ph ₃ P (1.5 equiv), BnOH (1 equiv), THF, μ W = 100W, 50 °C, 10 min	85	>95% conversion of 4-6a

14	4-6a (1 equiv), DIAD (1.5 equiv), Ph ₃ P (1.5 equiv), BnOH (1 equiv), THF, 50 °C (oil bath), 5 h	-	No reaction
----	---	---	----------------

a) based on the ¹H NMR spectra of the crude reaction mixture; b) refers to pure isolated compound after the flash column chromatography.

4.3.1.2 Optimization of base promoted alkylations

Apart from Mitsunobu alkylations, we performed alkylations using alkylhalides. These reactions were carried out using standard procedure for base (K₂CO₃) promoted alkylations and provided dialkylated sulfonamides **4-6aa** in very good to excellent yields. Regarding alkylations, both primary and secondary alkylhalides were utilized. Expected lower reactivity of secondary alkylhalides in nucleophilic substitution (steric hindrance) required higher temperature of the reaction (Scheme 71).

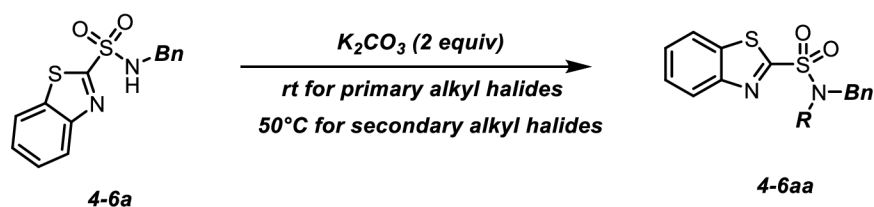

Scheme 71 - General scheme for base promoted alkylations

4.3.1.3 Scope and limitation of Fukuyama-Mitsunobu and base-promoted alkylations of BT-sulfonamides

Having optimized reaction conditions towards sulfonamides alkylations, the substrate scope and limitation were investigated. Both methods were suitable for primary halides/alcohols yielding *N,N*-dialkylated sulfonamides **4-6** in decent yields. When secondary alcohols were used, Fukuyama-Mitsunobu reaction proceeded in very good yields and with full stereoinversion **4-6ae**, **4-6af**. In all examples, the microwave conditions showed excellent functional group tolerance under Fukuyama-Mitsunobu alkylations. Using this approach, the reaction of chiral sulfonamides with ethyl lactate yielded the *meso*-compound **4-6da**. It should be also noted, that in any case we did not observe the formation of the alcohol elimination side product, that is regularly present in the case of secondary alcohols (Table 11).⁹⁹

Table 11– Scope and limitations of BT-sulfonamide N-alkylations

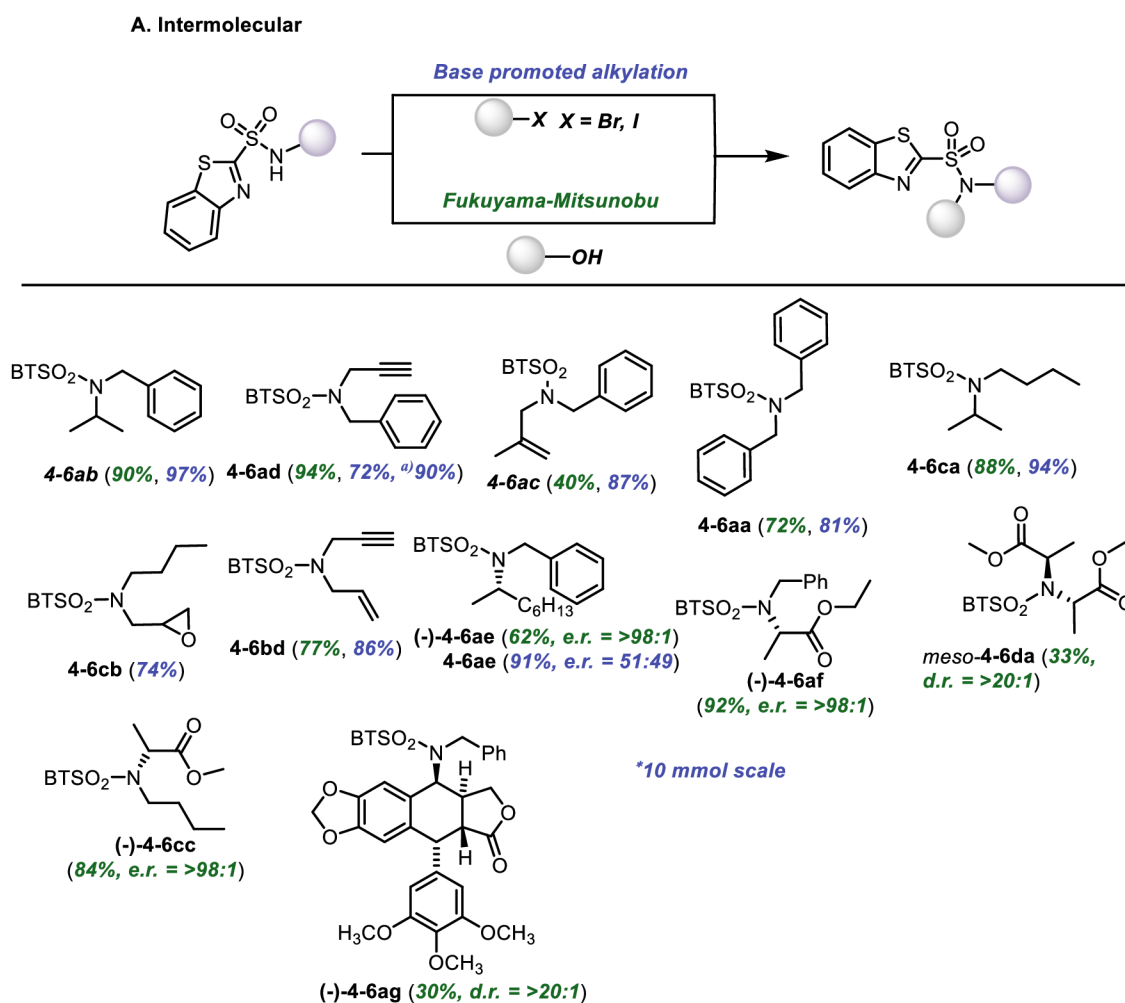

Fukuyama-Mitsunobu alkylations proceed also in an intramolecular manner. Using this procedure, seven membered azepane ring was prepared. The whole procedure that was carried out in the two-pot protocol starting from sulfinic salt yielding B T SO $_2$ -azepane derivative **4-51** in 59 % yield (Scheme 72).

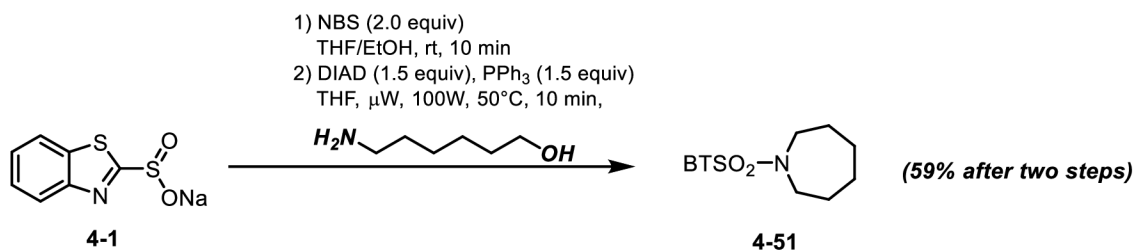

Scheme 72 – Intramolecular Mitsunobu reaction

Similarly, when hydroxy group-containing sulfonamide **4-6l** were reacted under the FMA protocol, aziridine ring containing sulfonamide **4-52** were prepared. Unfortunately, such compounds were highly unstable during the attempts of their isolation (unstable on SiO $_2$).

Therefore, we attempted the direct transformation of obtained crude products. First, we used those compounds as precursors to azomethine ylides **4-53** that could undergo 1,3-dipolar cycloadditions with different dipolarophiles **4-57**, **4-58**, **4-59**. Unfortunately, we failed to find suitable conditions and we did not observe any reaction occurring. Next, several efforts to open aziridine ring **4-52** with with external nucleophiles **4-55**, **4-56** gave only complex reaction mixtures (Scheme 73).

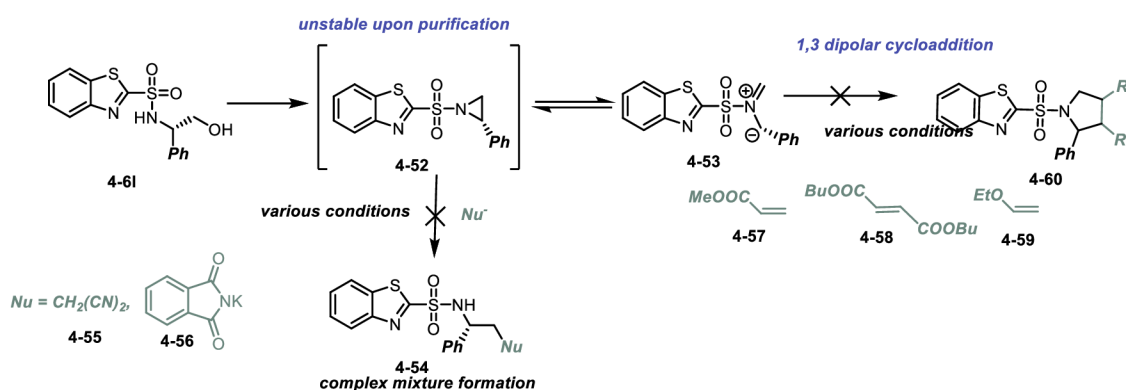

Scheme 73 – Attempts for aziridine isolation

4.3.2 Transition metal promoted reactions

Since we were able to prepare *N,N*-dialkylated sulfonamides **4-6**, we turned our attention towards the preparation of sulfonamides with direct *N*-sp² carbon bond (*N,N*-arylalkyl sulfonamides). Based on literature research, two approaches to such compounds were selected. Firstly, Pd-promoted Buchwald-Hartwig^{154,155} amination and the second copper-catalyzed Chan-Lam coupling (Scheme 74).^{156, 157}

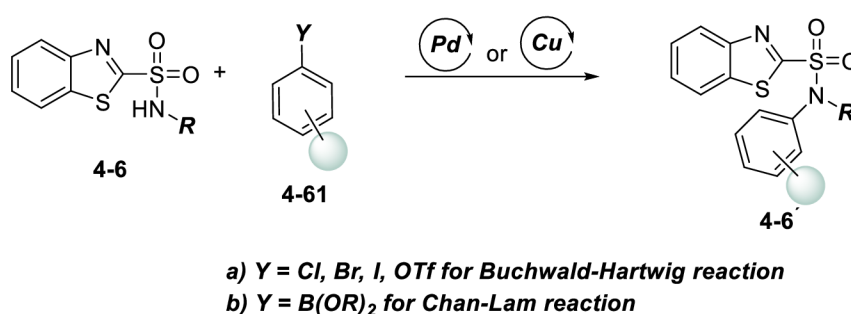

Scheme 74 – Selected General scheme of transition metal catalysed reaction of BT-sulfonamides

4.3.2.1 Buchwald-Hartwig amination

Buchwald-Hartwig amination is one of the most convenient ways how to forge *N*-C(sp²) bond. This reaction uses palladium species as the catalyst and aryl(pseudo)halides **4-61** as the electrophilic coupling partners. Unfortunately, after several screening experiments, we failed to observed formation of desired *N,N*-alkylaryl

sulfonamides **4-6**. Interestingly, in most cases, only elimination of SO₂ from sulfonamide **4-6** was observed and BT-amine **4-62** was isolated as the only product of the reaction. Analogically with SO₂ extrusion from arylsulfones described by Hong et al.¹⁵⁸ In that case, nickel(0) catalyst undergoes oxidative addition to S-C bond (**B**), where after the migration and reductive elimination is generated similar type of product (Scheme 75). To confirm this analogy with our observations we performed several control experiments that are discussed below.

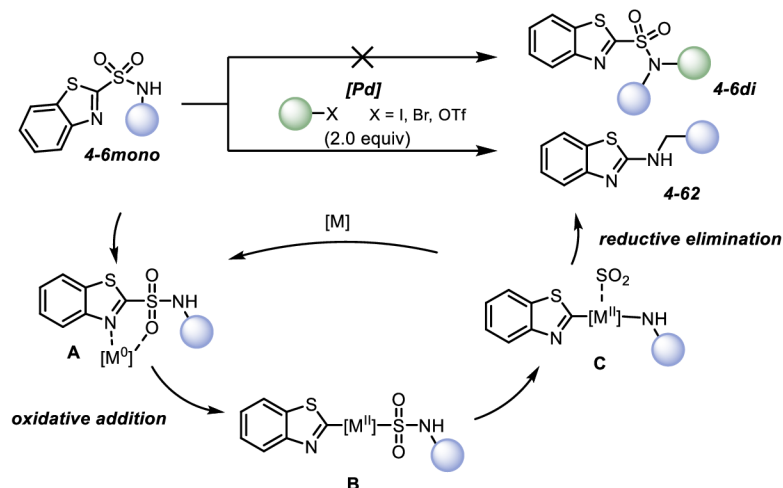

Scheme 75 – General reaction mechanisms of desulfurylation

Surprisingly, no product **4-62** formation was observed when Pd⁰-mediated SO₂ extrusion was attempted on the **4-6a** without the presence of aryl iodide (Scheme 76, Eq 1). Suggesting, phenyl iodide plays an important role, substoichiometric amount of PhI was used (Scheme 76, Eq 4). In this case SO₂-free compound **4-62** was formed in 11 % yield. These results pointed towards the crucial role of Pd(II) species in reaction mechanism. To confirm the necessity of Pd(II) intermediate, the reaction was carried out in the absence of Ph-I and in the presence of catalytic amount of (PPh₃)₂PdCl₂ (5 mol %). The BT-amine **4-62** was formed in 6% yield (Scheme 76, Eq 5). Next, we questioned the necessity of the base in the reaction mixture. Thus the reaction was performed in the presence of Cs₂CO₃ and Pd(II). Thus, compounds **4-62** was isolated in significantly higher yield of 76 % (Scheme 76, Eq 6).

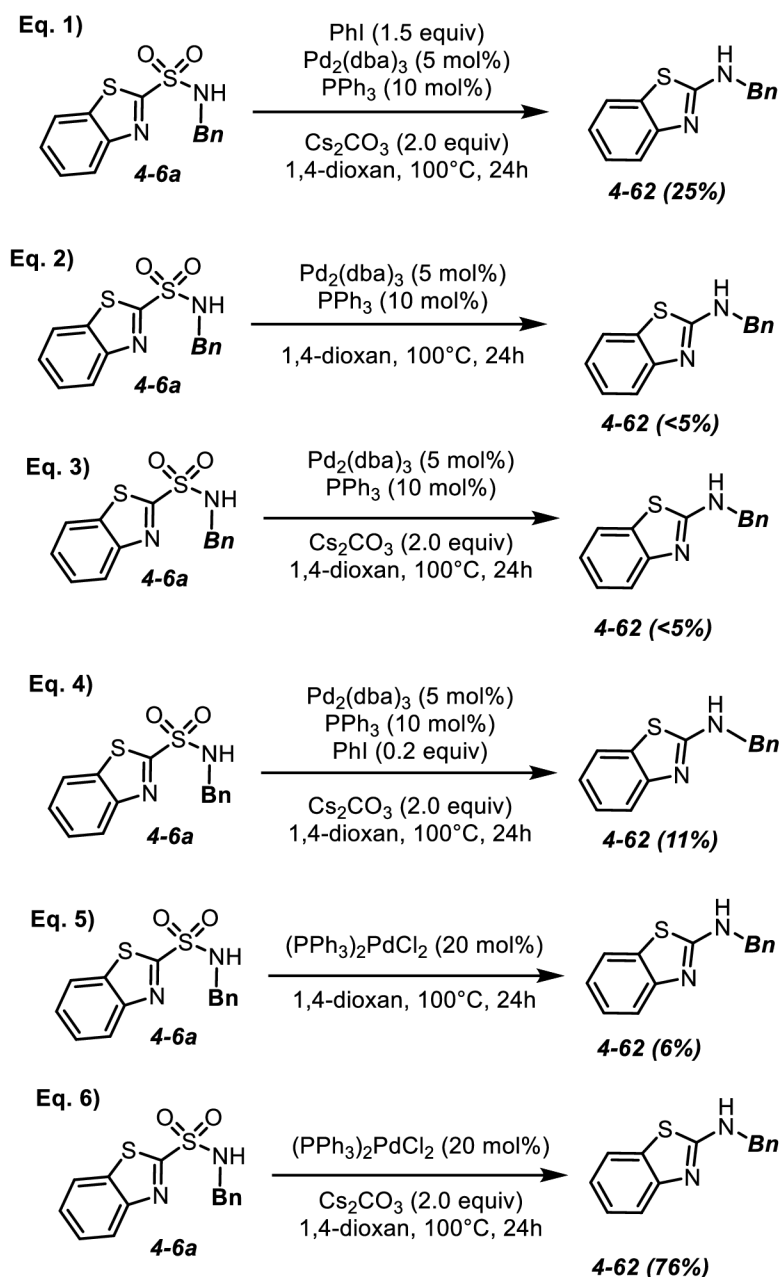

Scheme 76 – Control experiments that allow us to evaluate the role of various reaction conditions

The fact that Pd(II) is the real promoter of the **4-6** to **4-62** transformation, allowed us to propose the reasonable reaction mechanism. It is obvious that Pd(II) can not undergo the oxidative addition to C-S bond. On the other hand, it can behave as the Lewis acid and it might activate intramolecular rearrangement that leads to intermediate **C**. The extrusion of SO₂ from **D** followed by the anion reprotonation/desulfurylation (Scheme 77).

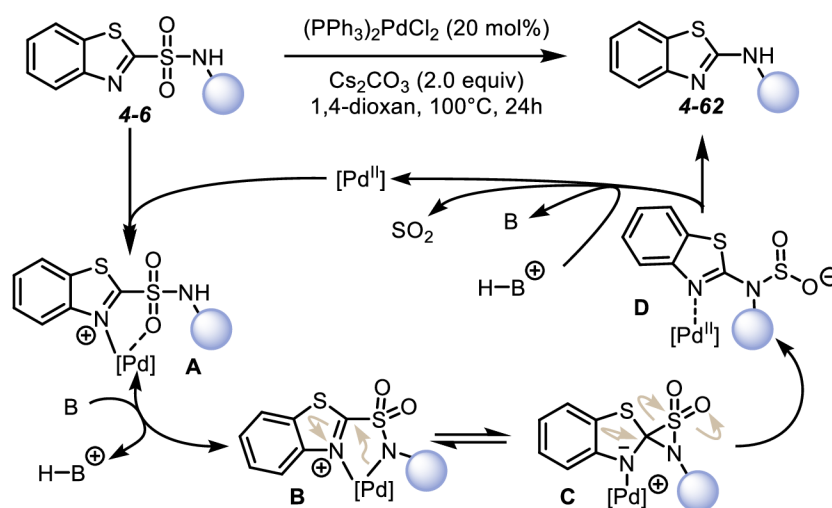

Scheme 77 – Proposed reaction mechanism of the transformation of 4-6 to 4-62

4.3.2.1.1 Chan-Lam coupling

After unsuccessful attempts to form N-C(sp²) bond using Pd promoted coupling, our attention turned towards Chan-Lam coupling copper promoted reaction with boronic acids derivatives with N-nucleophiles.^{159,160} Based on the literature precedens it seems that the use of BT-sulfonamides **6-4** might be rather problematic.¹⁶¹ Indeed, the literature reports in general demonstrated only few different heteroarylsulfonamides that those substrates are rather unreactive in Chan-Lam coupling. The reason behind is in their lower nucleophilicity (generated anion is too stable and therefore less reactive) and in additional interaction of lone pairs of heteroatoms present in the heterocycle with the copper catalyst. Nevertheless, we started to explore BT-sulfonamide **4-6** reaction with phenylboronic acid **4-61b** with the aim to find suitable reaction condition for Chan-Lam coupling. The starting point, and the direction of our optimization came from the excellent mechanistic study from Watson et al.¹⁵⁷ They sum up their observations and hypothesis about the most important events that occurs within Chan-Lam coupling cycle. The general mechanism of this coupling is well established, and it is believed that it starts with copper intermediate in the oxidation state II **B**, that after ligand exchange undergoes transmetalation. Copper species is then oxidized from the oxidation state II to III (**C** to **D**). After the reductive elimination, Copper(I) **E** is reoxidized to copper(II) **B**.¹⁶¹ The authors point out the importance oxidation turnover from copper(I) **E** to copper(II) **B**. This moment is very important, since it has important ramifications in amination reaction. Indeed, the protodeboronation, oxidation and homocoupling reaction are in general facilitated by Cu(I) **E** species rather than Cu(II). In addition, Chan-Lam coupling proceeds with rather high catalyst loading because under those conditions, the copper

species also act as the main oxidant.¹⁵⁷ Also the organoboron compounds must be used in excess to maintain efficiency due to the competing side reactions. The oxidation of Cu(I) **E** to Cu(II) **B** is more effective when more electron-donating ligands (N-methylpiperidine > AcO⁻) are used due to greater electron density on copper atom.¹⁶² Furthermore, the free boronic acids **4-61b** are preferred to organoboron species based on Bpin, since pinacole can lead to catalyst inhibition (Scheme 78).

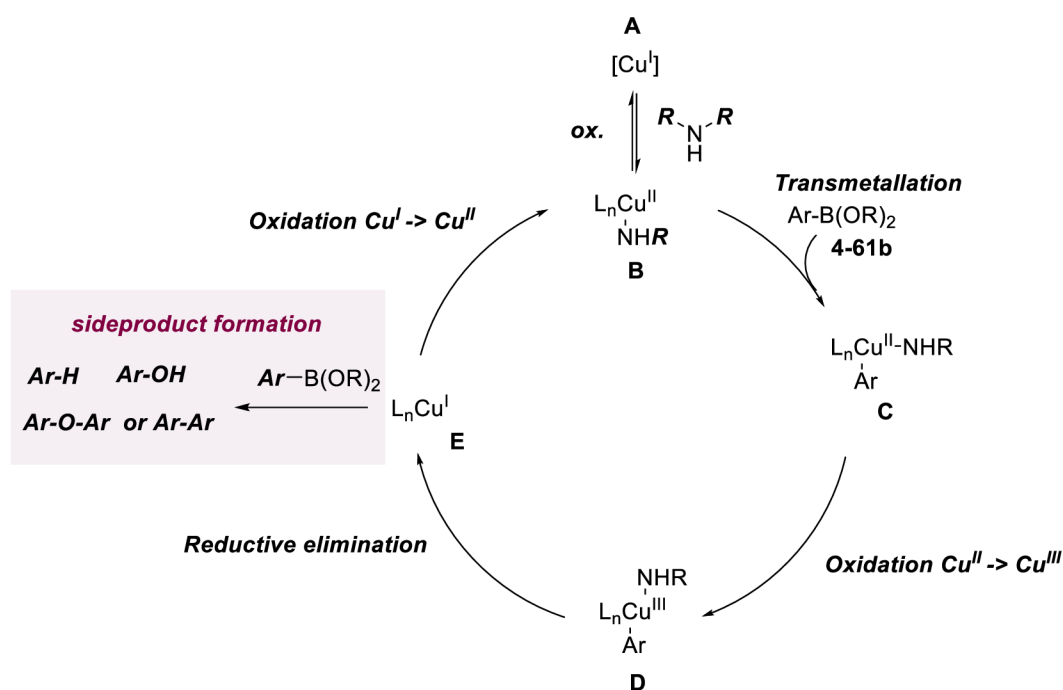

Scheme 78 – General catalytic cycle for Chan-Lam coupling

Being aware of all these facts, we started to look for the ideal reaction conditions screening various sources of copper together with various bases that at the same time act as ligands. The complete set of reaction conditions optimization can be found in table (Table 12). To sum up the findings: **1)** We observed better reaction yields when O₂ (1 atm) was used. **2)** the reaction was carried out in DCE. **3)** The role of several copper sources was also investigated. Reactions using copper(II) precatalyst did not yield the desired products. In the case of copper(I) precatalysts, the role of counter anion proved to be crucial. When we used copper with inner space ligand as chloride, bromide, iodide, nitrile or acetate, only a low conversion of the starting sulfonamide was observed. Such observations are in agreement with the literature,¹⁵⁷ suggesting that substrates with low nucleophilicity are very slow in the ligand exchange. From that reasons, we decided to use cationic copper source with hexafluorophosphate counteranion where ligand exchange should be rapid. **4)** The role of ligand proved to be also crucial. As described by

Watson, Cu(I) species can catalyze side reactions (protodeborylation). So rapid oxidation of Cu(II) is desirable. Such re-oxidation is accelerated by the presence of more electron-donating ligands. In our hands, the use of tetramethylethylenediamine (TMEDA) as an electron-donating bidentate ligand gave the best results. It was observed that the optimal amount of TMEDA loading is 4 equivalents. When a lower amount was used, the reaction yields dropped considerably.¹⁵⁷

Table 12 – Optimization of Chan-Lam coupling between sulfonamide 4-6a and phenylboronic acid

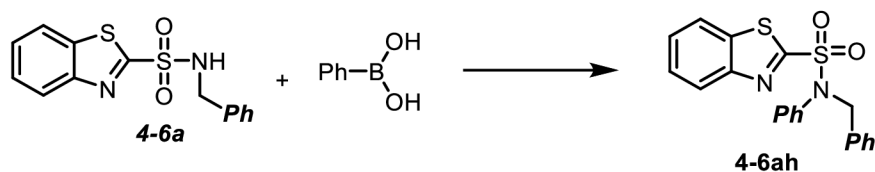

Entry	Reaction Conditions	Yield (%) ^{b)}	Conversion of 4-6a ^{a)}
1	4-6a (1 equiv), iPr ₂ NEt (1.5 equiv), CuCl (0.4 equiv), PhB(OH) ₂ (2 equiv), 1,4-dioxan, rt, overnight, open vessel	-	<5 % conversion
2	4-6a (1 equiv), tBuOK (1.5 equiv), CuCl (0.4 equiv), PhB(OH) ₂ (2 equiv), 1,4-dioxan, rt, overnight, open vessel	-	<5 % conversion
3	4-6a (1 equiv), Cs ₂ CO ₃ (1.5 equiv), CuCl (0.4 equiv), PhB(OH) ₂ (2 equiv), 1,4-dioxan, rt, overnight, open vessel	-	<5 % conversion
4	4-6a (1 equiv), Et ₃ N (1.5 equiv), CuCl (0.4 equiv), PhB(OH) ₂ (2 equiv), 1,4-dioxan, rt, overnight, open vessel	-	<5 % conversion
5	4-6a (1 equiv), Et ₃ N (8 equiv), CuCl (0.4 equiv), PhB(OH) ₂ (2 equiv), 1,4-dioxan, rt, overnight, open vessel	-	<5 % conversion
6	4-6a (1 equiv), TMEDA (10 equiv), CuCl (0.4 equiv), PhB(OH) ₂ (2 equiv), DCE, rt, overnight, open vessel	n/d	25 % conversion
7	4-6a (1 equiv), TMEDA (10 equiv), CuBr (0.4 equiv), PhB(OH) ₂ (2 equiv), DCE, rt, overnight, open vessel	n/d	48 % conversion

8	4-6a (1 equiv), TMEDA (10 equiv), CuI (0.4 equiv), PhB(OH) ₂ (2 equiv), DCE, rt, overnight, open vessel	12	52 % conversion
9	4-6a (1 equiv), TMEDA (10 equiv), CuI (0.4 equiv), PhB(OH) ₂ (2 equiv), toluen, rt, overnight, open vessel	-	<5 % conversion
10	4-6a (1 equiv), TMEDA (10 equiv), CuCN (0.4 equiv), PhB(OH) ₂ (2 equiv), DCE, rt, overnight, open vessel	-	43 % conversion
11	4-6a (1 equiv), TMEDA (10 equiv), CuCN (0.4 equiv), PhB(OH) ₂ (2 equiv), DCE, rt, overnight, open vessel	-	<5 % conversion
12	4-6a (1 equiv), TMEDA (10 equiv), CuBr (0.4 equiv), PhB(OH) ₂ (2 equiv), toluen, rt, overnight, open vessel	8	49 % conversion
13	4-6a (1 equiv), TMEDA (10 equiv), CuCl (0.4 equiv), PhB(OH) ₂ (2 equiv), toluen, rt, overnight, open vessel	n/d	51 % conversion
14	4-6a (1 equiv), TMEDA (4 equiv), CuCl (0.4 equiv), PhB(OH) ₂ (2 equiv), DCE, -60 °C, overnight	-	<5 % conversion
15	4-6a (1 equiv), TMEDA (4 equiv), CuCl (0.4 equiv), PhB(OH) ₂ (2 equiv), DCE, reflux, overnight, O ₂ balloon	n/d	50 % conversion
16	4-6a (1 equiv), Et ₃ N (6 equiv), Cu(OAc) ₂ (0.4 equiv), PhB(OH) ₂ (2 equiv), DCE, rt, 24 h, open vessel	-	<5 % conversion
17	4-6a (1 equiv), TMEDA (6 equiv), Cu(OAc) ₂ (0.4 equiv), PhB(OH) ₂ (2 equiv), DCE, rt, 24 h, O ₂ balloon	-	<5% conversion
18	4-6a (1 equiv), TMEDA (4 equiv), CuCl (0.4 equiv), PhB(OH) ₂ (2 equiv), DCE, rt, overnight, O ₂ balloon	-	<5 % conversion
19	4-6a (1 equiv), TMEDA (4 equiv), CuCl (0.4 equiv), PhB(OH) ₂ (2 equiv), DCE, rt, 24 h, O ₂ balloon	n/d	68 % conversion

20	4-6a (1 equiv), TMEDA (4 equiv), CuCl (0.6 equiv), PhB(OH) ₂ (2 equiv), DCE, rt, 2 h, O ₂ balloon	n/d	69 % conversion
21	4-6a (1 equiv), TMEDA (8 equiv), CuCl (0.4 equiv), PhB(OH) ₂ (2 equiv), DCE, rt, 22 h, O ₂ balloon	n/d	62 % conversion
22	4-6a (1 equiv), TMEDA (10 equiv), CuCl (0.4 equiv), PhB(OH) ₂ (2 equiv), DCE, rt, 22 h, O ₂ balloon	n/d	57 % conversion
23	4-6a (1 equiv), TMEDA (4 equiv), CuCl (0.4 equiv), PhB(OH) ₂ (2 equiv), DCE, rt, overnight, O ₂ balloon	n/d	46 % conversion
24	4-6a (1 equiv), TMEDA (8 equiv), CuCl (0.4 equiv), PhB(OH) ₂ (2 equiv), DCE, rt, overnight, O ₂ balloon	n/d	47 % conversion
25	4-6a (1 equiv), Et ₃ N (6 equiv), Cu(OAc) ₂ (0.4 equiv), PhB(OH) ₂ (2 equiv), DCE, rt, 72 h, O ₂ balloon	23	70 % conversion
26	4-6a (1 equiv), TMEDA (4 equiv), [Cu(CH ₃ CN) ₄]PF ₆ (0.4 equiv), PhB(OH) ₂ (2 equiv), DCE, rt, 2 h, O ₂ balloon	67	82 % conversion
27	4-6a (1 equiv), TMEDA (6 equiv), [Cu(CH ₃ CN) ₄]PF ₆ (0.4 equiv), PhB(OH) ₂ (2 equiv), DCE, rt, 18 h, O ₂ balloon	48	86 % conversion
28	4-6a (1 equiv), tBuOK (8 equiv), [Cu(CH ₃ CN) ₄]PF ₆ (0.4 equiv), PhB(OH) ₂ (2 equiv), 1,4-dioxan, rt, overnight, O ₂ balloon		<5 % conversion
29	4-6a (1 equiv), Cs ₂ CO ₃ (8 equiv), [Cu(CH ₃ CN) ₄]PF ₆ (0.4 equiv), PhB(OH) ₂ (2 equiv), 1,4-dioxan, rt, overnight, O ₂ balloon		<5 % conversion
30	4-6a (1 equiv), TMEDA (6 equiv), [Cu(CH ₃ CN) ₄]PF ₆ (0.4 equiv), PhB(OH) ₂ (2.5 equiv), DCE, rt, 3 h, O ₂ balloon	25 %	86 % conversion
31	4-6a (1 equiv), TMEDA (6 equiv), [Cu(CH ₃ CN) ₄]PF ₆ (0.4 equiv), PhB(OH) ₂ (1 equiv), DCE, rt, 1,5 h, O ₂ balloon	n/d	65 % conversion

32	4-6a (1 equiv), TMEDA (6 equiv), [Cu(CH ₃ CN) ₄]PF ₆ (1 equiv), PhB(OH) ₂ (2 equiv), DCE, rt, 1,5 h, O ₂ balloon	n/d	80 % conversion
33	4-6a (1 equiv), TMEDA (6 equiv), [Cu(CH ₃ CN) ₄]PF ₆ (0.3 equiv), PhB(OH) ₂ (2 equiv), DCE, rt, 2 h, O ₂ balloon	n/d	74 % conversion
34	4-6a (1 equiv), TMEDA (6 equiv), [Cu(CH ₃ CN) ₄]PF ₆ l (0.3 equiv), PhB(OH) ₂ (2.5 equiv), DCE, rt, 18 h, O ₂ balloon	n/d	83 % conversion
35	4-6a (1 equiv), TMEDA (6 equiv), [Cu(CH ₃ CN) ₄]PF ₆ (0.2 equiv), PhB(OH) ₂ (2.5 equiv), DCE, rt, 18 h, O ₂ balloon	n/d	66 % conversion
36	4-6a (1 equiv), iPr ₂ N ₂ Et (8 equiv), [Cu(CH ₃ CN) ₄]PF ₆ (0.4 equiv), PhB(OH) ₂ (2 equiv), 1,4-dioxan, rt, overnight, O ₂ balloon	n/d	26 % conversion
37	4-6a (1 equiv), Et ₃ N (8 equiv), [Cu(CH ₃ CN) ₄]PF ₆ (0.4 equiv), PhB(OH) ₂ (2 equiv), 1,4-dioxan, rt, overnight, O ₂ balloon	n/d	18 % conversion
38	4-6a (1 equiv), Et ₃ N (4 equiv), [Cu(CH ₃ CN) ₄]PF ₆ (0.4 equiv), PhB(OH) ₂ (2 equiv), 1,4-dioxan, rt, overnight, O ₂ balloon	n/d	20 % conversion
39	4-6a (1 equiv), Et ₃ N (1 equiv), [Cu(CH ₃ CN) ₄]PF ₆ (0.4 equiv), PhB(OH) ₂ (2 equiv), 1,4-dioxan, rt, overnight, O ₂ balloon	n/d	11 % conversion
40	4-6a (1 equiv), TMEDA (4 equiv), [Cu(CH ₃ CN) ₄]PF ₆ (0.4 equiv), PhB(OH) ₂ (2 equiv), 1,4-dioxan, rt, overnight, O ₂ balloon	n/d	34 % conversion
41	4-6a (1 equiv), TMEDA (4 equiv), [Cu(CH ₃ CN) ₄]PF ₆ (0.4 equiv), PhB(OH) ₂ (2 equiv), DCE, rt, overnight, O ₂ balloon	53 %	69 % conversion
42	4-6a (1 equiv), TMEDA (4 equiv), [Cu(CH ₃ CN) ₄]PF ₆ (0.4 equiv), PhB(OH) ₂ (2 equiv), toluene, rt, overnight, O ₂ balloon	n/d	57 % conversion
43	4-6a (1 equiv), TMEDA (4 equiv), [Cu(CH ₃ CN) ₄]PF ₆ (0.4 equiv), PhB(OH) ₂ (2 equiv), DMSO, rt, overnight, O ₂ balloon	n/d	14 % conversion

44	4-6a (1 equiv), TMEDA (4 equiv), [Cu(CH ₃ CN) ₄]PF ₆ (0.4 equiv), PhB(OH) ₂ (2 equiv), CH ₃ CN, rt, overnight, O ₂ balloon	n/d	26 % conversion
45	4-6a (1 equiv), TMEDA (1 equiv), [Cu(CH ₃ CN) ₄]PF ₆ (0.4 equiv), PhB(OH) ₂ (2 equiv), DCE, rt, overnight, O ₂ balloon	n/d	38 % conversion
46	4-6a (1 equiv), TMEDA (2 equiv), [Cu(CH ₃ CN) ₄]PF ₆ (0.4 equiv), PhB(OH) ₂ (2 equiv), DCE, rt, overnight, O ₂ balloon	n/d	46 % conversion

a) based on the ¹H NMR spectra of the crude reaction mixture; b) refers to pure isolated compounds after the flash column chromatography.

During the reaction conditions optimization, we observed the formation of the desired product **4-6ah** along with small amounts of biphenyl **4-63**. The presence of biphenyl **4-63** could be rationalized as a result of boronic acid **4-61b** homocoupling side reaction. The biphenyl **4-63** formation takes place when additional boronic acid, **4-61b** (present in excess compared to sulfonamide **4-6a**) coordinates to copper atom and force BT-sulfonamide (Scheme 79) decooordination.¹⁶³ The biphenyl **4-63** formation was observed in most Chan-Lam couplings experiments. Despite the presence of many signals in aromatic region, that makes the exact quantification difficult, we presume the ratio of product/biphenyl formation to be approximately 9:1 regardless the reaction conditions tested.

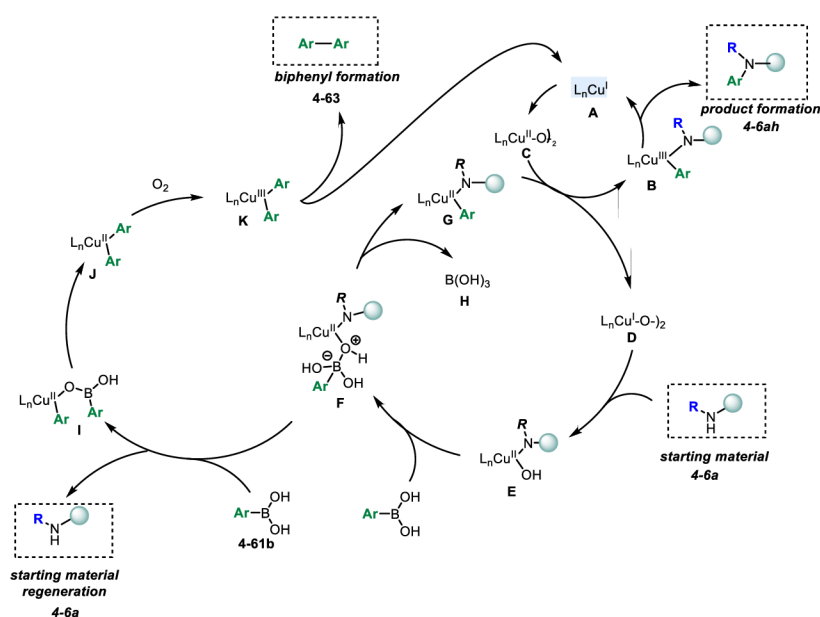

Scheme 79 – Proposed reaction mechanism for biphenyl formation

Having optimized the reaction conditions on phenyl boronic acid **4-61b** and *N*-benzylsulfonamide **4-6a**, we explored the scope and limitations of our method. Disappointingly, the scope of our Chan-Lam coupling reaction conditions proved to be rather limited. The best yields were obtained when non-substituted aromatic boronic acids **4-61b** were used as a starting material. Only boronic acids with 4-biphenyl, 3-methoxyphenyl and 3-fluoro and 4-halogen substitution provided the desired products **4-6al**, **4-6bl**, **4-6ai**, **4-6aj**, **4-6af**, **4-6ak**. On the other hand 4-carboxylic acid or ester-substituted phenyl boronic acids as well as 4-methoxyphenyl, or styryl derivatives did not provide any products. The only detected products in the reaction mixture were the products of boronic acids homocoupling **4-63** (Table 13).

Table 13- Scope and limitations of Chan-Lam coupling

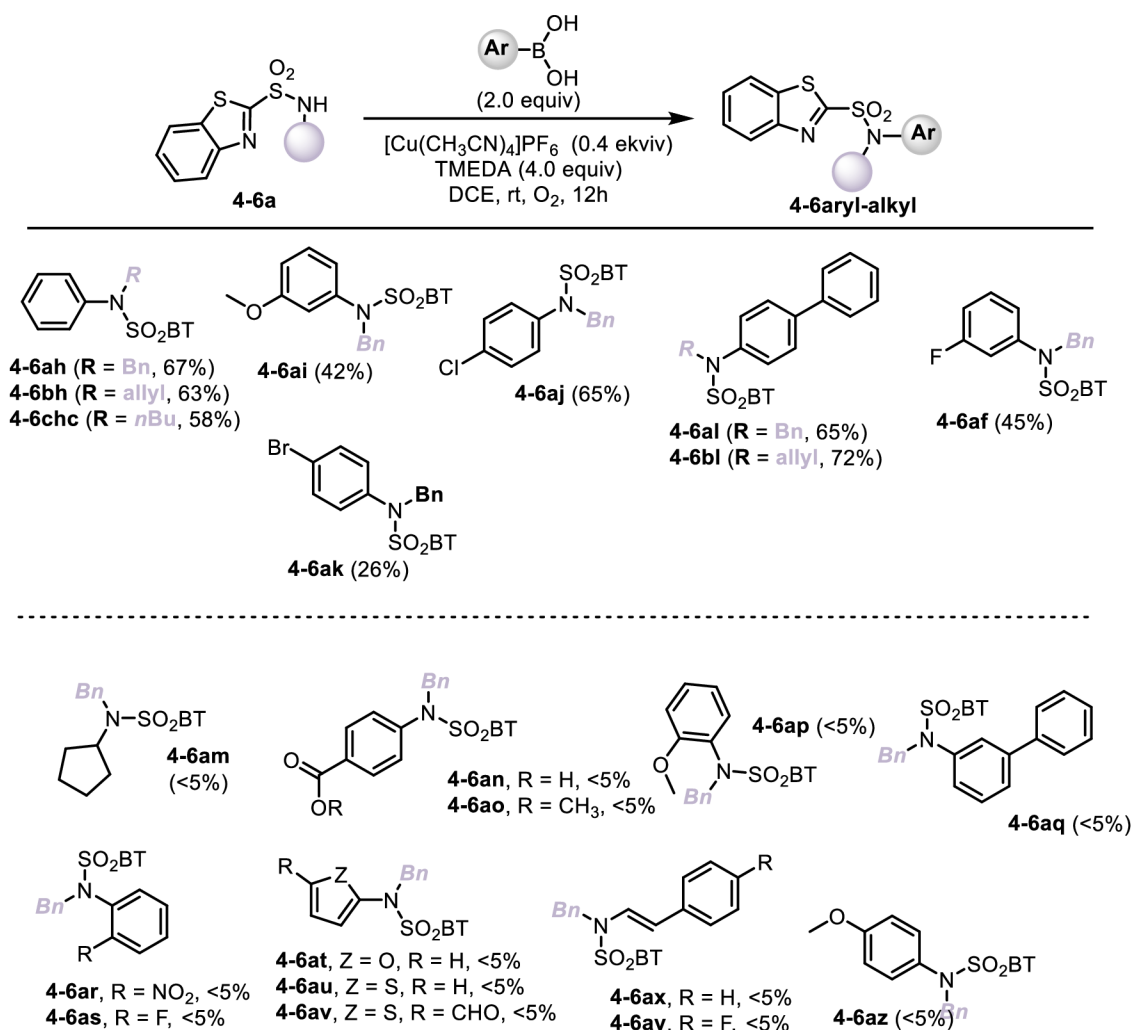

4.3.3 Smiles rearrangement

The Smiles rearrangement is well-known intramolecular nucleophilic aromatic substitution type reaction (Scheme 80).¹⁶⁴ The rearrangement takes an advantage of electron deficient nature of (hetero)aromatic rings, that are sufficiently activated for nucleophilic attack. It is also important that the resulting negative charge can be sufficiently stabilized.¹⁶⁵

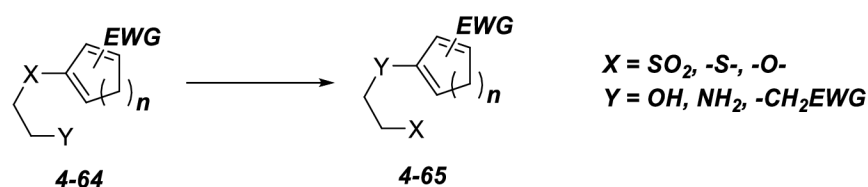

Scheme 80 – General mechanism of Smiles rearrangement

The Smiles rearrangement in combination with electron-deficient heterocycles e.g benzothiazoles or phenyltetrazoles has been used in very important olefination method Julia-Kocienski reaction.¹⁶⁶ This olefination as well as other use of it were in the center of interest of our group for quite some time (Scheme 81).^{167, 2}

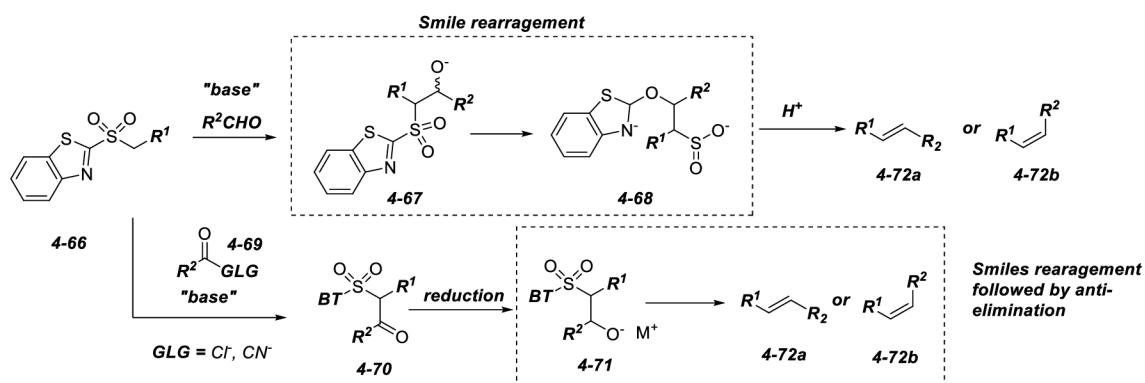

Scheme 81 – Modification of Julia-Kocienski exploration in our group

The number of reports exploring the sulfonamidic derivatives in Smiles rearrangement is very limited and majority originates from the group of M.F. Greaney.^{168–171} Our previous experience in the Smiles rearrangement area led us to propose the use of Smiles rearrangements in the context benzothiazolsulfonamide derivatives. We wanted to take an advantage of our synthetic ways to optically pure *N,N*-disubstituted BT-sulfonamides in context of stereoselective Smiles rearrangement. Upon our analysis, using this approach, simple esters of various aminoacids should be stereoselectively transformed into the corresponding α -aminoacids derivatives **4-73** bearing the quaternary center. The next question considered the stereoselectivity of this transformation. The unknown was the

configurational stability of the generated carbanion **4-74** under the reaction conditions. In other words, the question was if generated carbanion **4-74** would react faster (intramolecular transformation) with benzothiazole electrophilic center, or whether the enolate formation **4-76** would lead to complete racemization (Scheme 82).

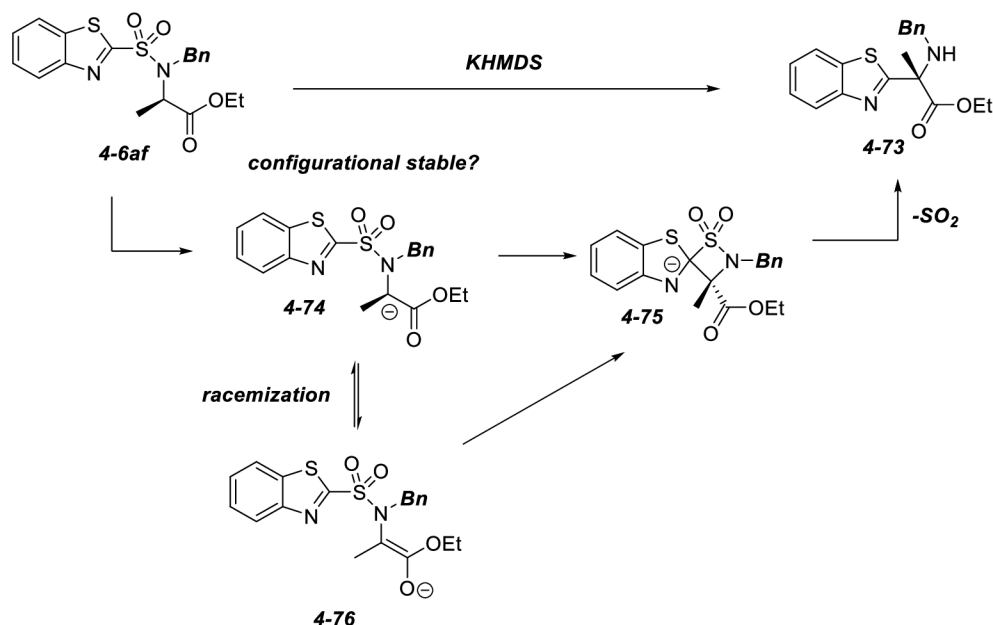

Scheme 82 – Proposed Smiles rearrangement based intermolecular transformation of α -amino acid derivatives

To validate our hypothesis, the reaction of sulfonamide **4-af** in the presence of *KHMDS* (non-nucleophilic base was used to avoid competitive addition to C_2 at BT-heterocycle) was carried out. In the first attempt, the **4-6af** was treated with 1.1 equiv of *KHMDS* in THF at -78°C . In less than 10 minutes, the full conversion of **4-6af** was observed and after the workup we were delighted to observe the formation of the desired product **4-73** in 16:84 e.r. (Table 14, Entry 1). Since the transformation of the rearrangement product **4-73** to the corresponding Mosher amides failed (no traces of product observed), we decided to tackle the problem by co-crystallization. However, the absolute configuration of the major enantiomer yet to be determined.

First, we varied reaction solvents (THF, Et_2O , DMF) and also the role of cation scavengers (18-crown-6). The best e.r. of obtained product **4-73** was 5:95 (Table 14, Entry 7). These outstanding results did bring up the question, what is the real intermediate that undergoes the Smiles rearrangement. During the hunt for improved stereoselectivity, the reaction of **4-6af** in the presence of *LHMDS* was attempted. The reaction proceeded well and immediately the reaction produced the desired product **4-73**. However, the opposite enantiomer was produced as the main product (e.r. 87:13) (Table 14, Entry 8). Our

attempts to reproduce this interesting transformation however started to resist (no product or only traces of product was formed) regardless the solvent or the lithiated base used (LDA). Finally, we observed that if freshly prepared LHMDS is generated prior the reaction, the formation of rearrangement product **4-6af** in 90:10 e.r (Table 14, Entry 10). At this moment my colleagues are working on the absolute stereochemistry determination and also explores the scope and limitations of the this Smiles rearrangement method. We believe this transformation can become possible a real powerful method heteroaryl- α -quarternary center containing α -aminoacids constructions. Especially since starting material are homochiral, both possible enantiomers could be independently prepared.

Table 14– Optimization of Smiles rearrangement

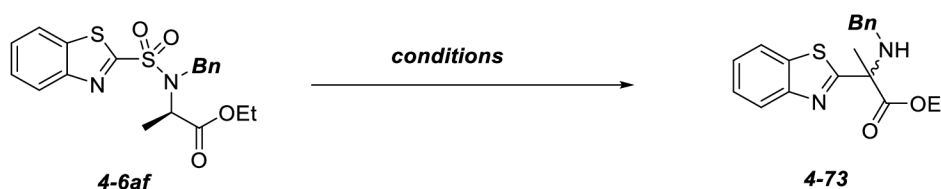

Entry	Reaction Conditions	er ^{a)}	Yield
1	KHMDS (1.1 equiv), THF, -78 °C, 15 mins	16:84	n.d.
3	KHMDS (1.5 equiv), 18-crown-6 (3.5 equiv), THF, -78 °C, 15 mins	11:88	n.d.
4	KHMDS (1.5 equiv), Et ₂ O, -78 °C, 30 mins	19:81	n.d.
5	KHMDS (1.5 equiv), Et ₂ O, -95 °C, 30 mins	80:20	n.d.
6	KHMDS (1.5 equiv), DMF, -50 °C, 30 mins	17:82	n.d.
7	KHMDS (1.5 equiv), 18-crown-6 (3.5 equiv), THF, -85 °C, 15 mins	5:95	n.d.
8	LHMDS (1.5 equiv), THF, -78 °C, 15 min	87:13	n.d.
9	LDA (6 equiv), THF, -78°C, 30min	-	traces
10	LHMDS (1.5 equiv), THF, -85 °C, 15 min	90:10	75 %

a) E.r. determined by chiral HPLC analysis of crude products

b) Refers to pure isolated product

4.3.4 BT-sulfonamides as *N*-protecting groups

Having developed short and efficient BT-sulfonamide synthesis, we wished to explore the compounds for potential use as a nitrogen protecting group. Especially, we focused on the chemoselective modification of aminogroups in the presence of other functionalities, especially alcohols. Starting from aminoalcohols **4-74**, **4-76**, we prepared orthogonally protected aminoalcohols **4-75**, **4-77** in chemoselective manner (Scheme 83). Targeted compounds **4-75** and **4-77** were obtained in good overall yields.

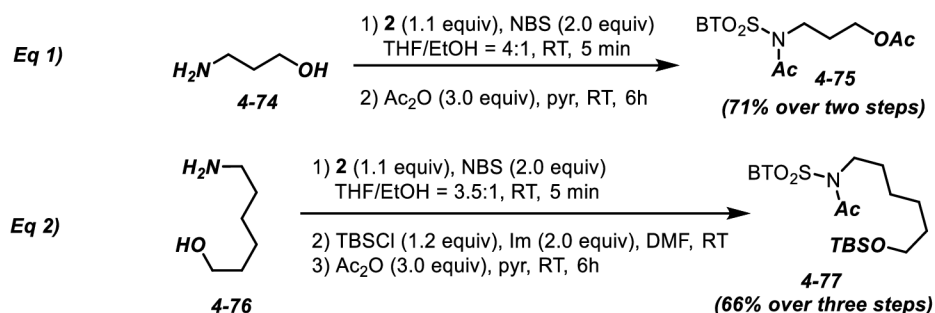

Scheme 83 – Chemoselective transformation of aminoalcohols to their orthogonally protected equivalents

Being able to selectively protect amino groups, selective removal of BT group was attempted. This step was accomplished by reaction of BT-sulfonamide **4-6aa** with NaBH_4 or EtSLi (Scheme 84). In both cases, the desired product **4-78** was obtained in excellent yield. This chemical properties could be used in selective nitrogen incorporation in late-stage functionalization of natural products.¹⁴⁷ The reaction is induced by the nucleophilic attack towards electrophilic centre on benzothiazole ring leading to SO_2 extrusion upon formation of secondary amines.

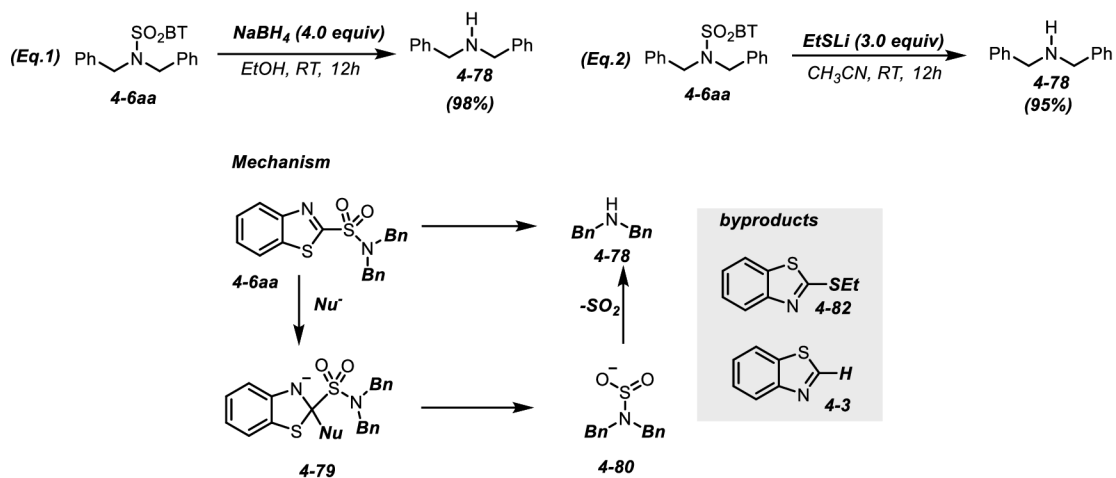

Scheme 84 – Benzothiazole group removal

4.4 Use of BT-sulfonamides as H-donors

4.4.1 Introduction

Hydrogen bond catalysis is a type of organocatalysis that take advantage of small molecule non-covalent interactions, in particular H-bond, in order to accelerate given transformation and to induce stereochemical outcome of the chemical process. Non-covalent interactions are considerably weaker, less distance dependent and less directional than covalent attractive interactions (HBD catalysis vs Bronsted acid catalysis – hydrogen bond complex formation vs ion pair formation) (Figure 20). However, an important stereocontrol can be achieved, if several non-covalent bonding interactions are present.¹⁷²

Figure 20 – HBD and Bronsted acid catalysis

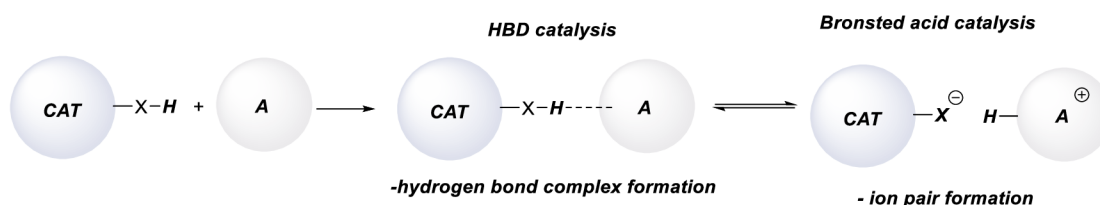

The pioneering studies that showed the role of H-bond concept in catalytic reactions were first demonstrated by Hine and co-workers in early 80's.¹⁷³ The authors showed that substituted phenols **4-83** can be used as H-bond catalyst during the oxirane ring-opening. (Scheme 85).

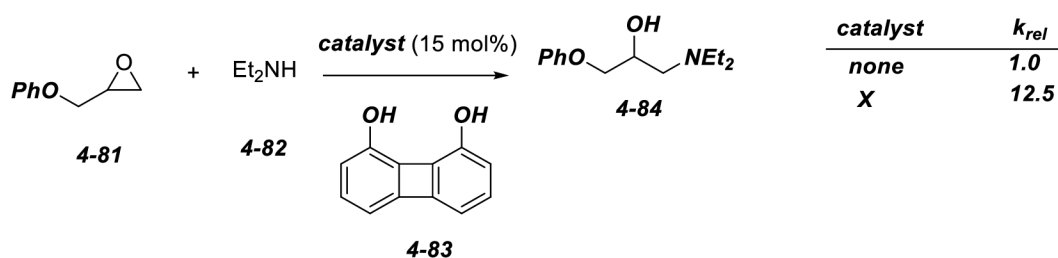

Scheme 85 – Pioneering work of Hine et al. reported for the first time as H-bond catalysis

In following years, many scientists turned their attention towards catalysis using non-covalent interactions. In 1994, Curran and his colleagues described for the first time the use of urea derivatives **4-87** as a very potent organic catalyst (Scheme 86).¹⁷⁴

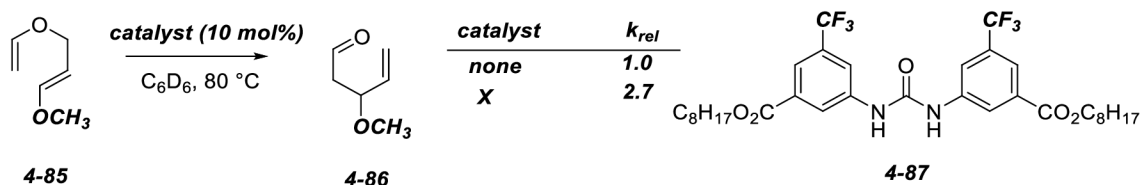

Scheme 86 – Urea catalyzed Claisen rearrangement

Since then, various chiral small molecules were used as very useful H-bond donor (HBD) catalysts and their application is spread widely in various fields of organic synthesis.¹⁷⁵ Typical example are aldol reactions,¹⁷⁶ Henry reaction,¹⁷⁷ Friedel-Crafts acylation,¹⁷⁸ or pericyclic reactions such as Diels-Alder reactions.¹⁷⁹ The HBD catalysts also contains a wide range of structural and functional motives. Among those, diol derivatives and urea derivatives are the most popular and exploited one (Scheme 87). Despite various structural patterns, the common sign of HBD catalysts is the presence of single or dual H-bond donor site along with additional functionalities capable of secondary interactions with substrates. Not surprisingly, the pK_a values of HBD catalysts used up to date vary in a wide range.¹⁷⁵ One can argue that catalysts with lower pK_a values than carboxylic acid derivatives behaves as Bronsted acid catalyst (Ion pair formation) and really, the mode of action can differ from case to case, and it is still part of ongoing discussion.

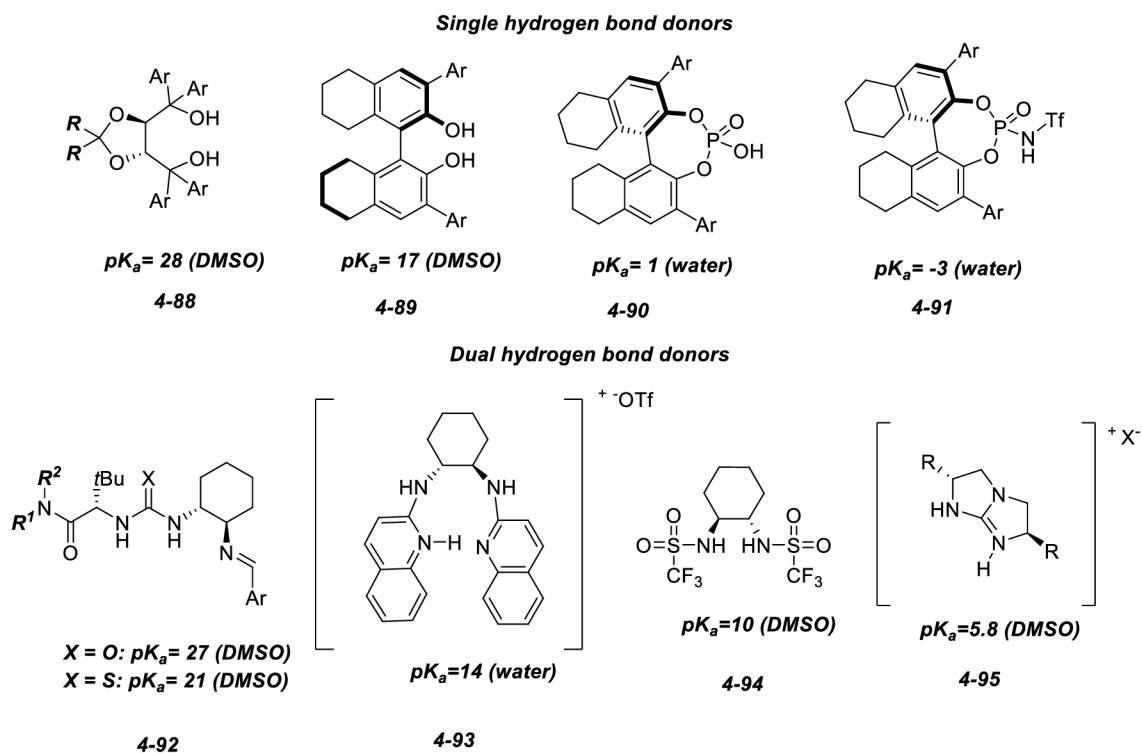

Scheme 87 – Overview of some HBD catalysts

4.4.2 Sulfonamide based HBD catalysts – synthesis and evaluation

Our “hunt” for efficient HBD catalysts started with previously prepared sulfonamides **CatA-C**. In addition to those, we decided to prepare BT-sulfonamide-containing bifunctional catalyst that would also include urea moiety **CatD** (Scheme 88).

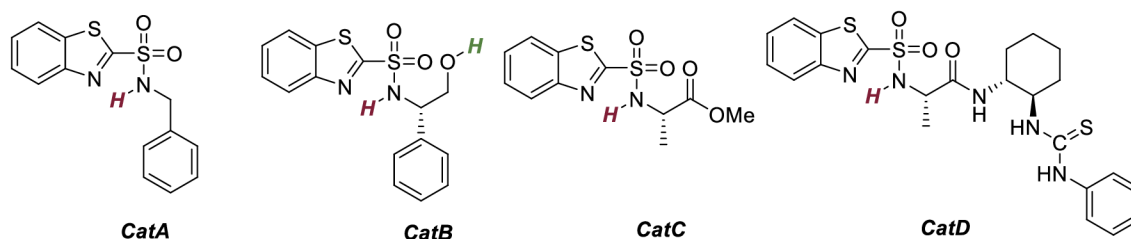

Scheme 88 – Selected sulfonamides for HBD catalysis screening

The development of this catalyst was inspired by the work of Seidel et al.¹⁸⁰ We expected that our bifunctional catalyst could stabilize conjugate base of acidic sulfonamidic proton in intramolecular fashion (*vide infra*). This stabilization would increase the acidity and promoted Bronsted acid catalysed reactions. The synthesis of **4-100** was straightforward and starts with BT-alanine derivative **4-6p** (Scheme 89).

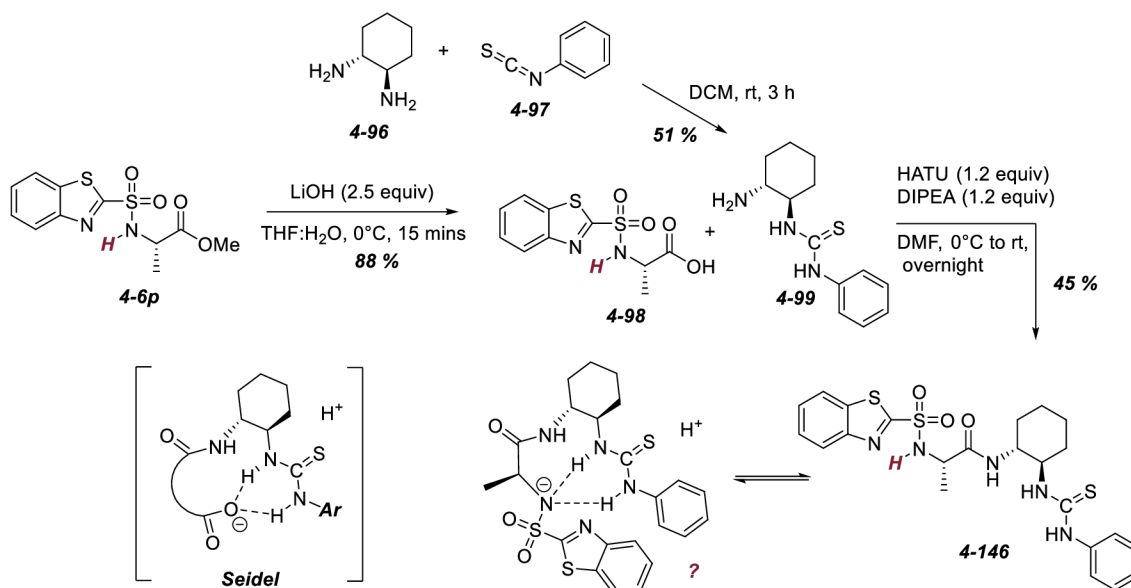

Scheme 89 – Preparation of thiourea catalyst

Having all designed HBD catalysts in hand, their evaluation began. Inspired by work of Mikami and co-workers,¹⁸¹ we investigated the availability of hydrogen bond donor by screening mixtures of potential HBD catalyst with hydrogen bond donor acceptor (lactone **4-100**). The authors measured a series of mixtures composed of different ratios of the lactone/HBD catalyst and compared their ¹H NMR chemical shift (Scheme 90). The main

interest was focused on the sulfonamidic hydrogens and α -hydrogens of lactone **4-100**, because those in the mixture of such compounds, changed their chemical shift (formation of the H-bond). Comparing the chemical shift between each sample, they were able to prove a presence of hydrogen bonding together with its bonding pattern (single or double HBD).

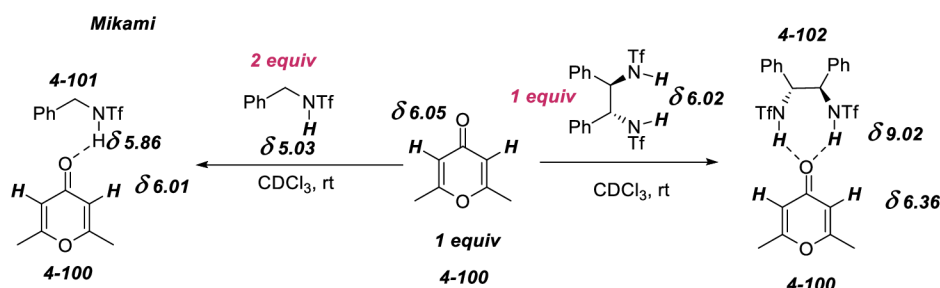

Scheme 90 – The influence of HBD donors as the chemical shift of α -hydrogen atoms

Evaluated NMR samples were prepared using lactone (0.06 mol/l) in CDCl₃ and evaluated in NMR tube. In case of BT-sulfonamides, analysis of ¹H NMR signals revealed significant increase in chemical shift of amidic donors. Using this approach, single or double bonding pattern could be determined. First, single benzylated BT-sulfonamide **CatA** was investigated using this protocol (Table 15). Despite the change in chemical shift ($\Delta\sigma = 0.46$ for **CatA**) of amidic proton signal (Red, Table 15, Graph 2), the difference is not that significant as was described by Mikami¹⁸¹ et al. ($\Delta\sigma = 0.83$ for **4-101**). The lower upfield shift of amidic hydrogen of **CatA** as well as lactone α -hydrogens **4-100** ($\Delta\sigma = 0.01$ vs 0.04 ppm for Mikami **4-101**) suggests much lower carbonyl activation (Blue, Table 15, Graph 1).

Table 15 – The influence of sulfonamide **CatA** on the lactone **4-100** ¹H-NMR shift

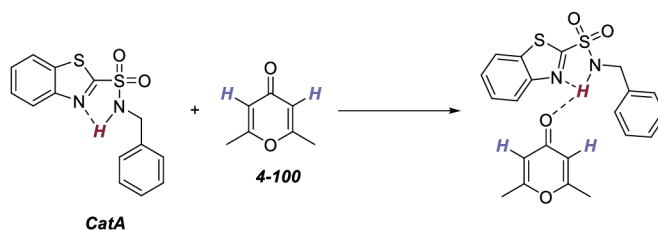

Entry	lactone/CatA(n/n)	ppm (NH)	ppm (CH)
1	0	5.46	6.0500
2	0.54	5.92	6.0485
3	1	6.08	6.0485
4	2	6.39	6.0430

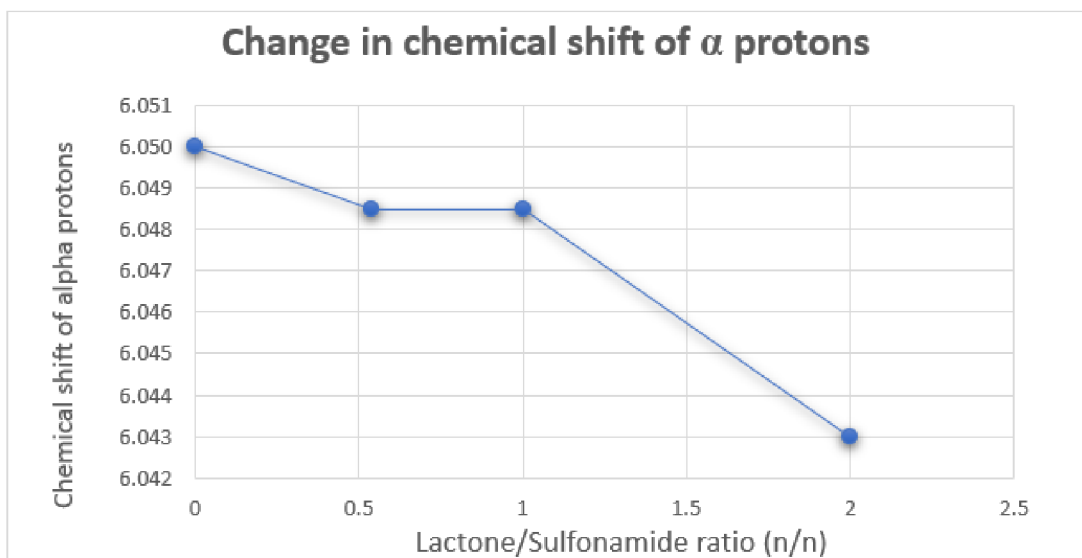
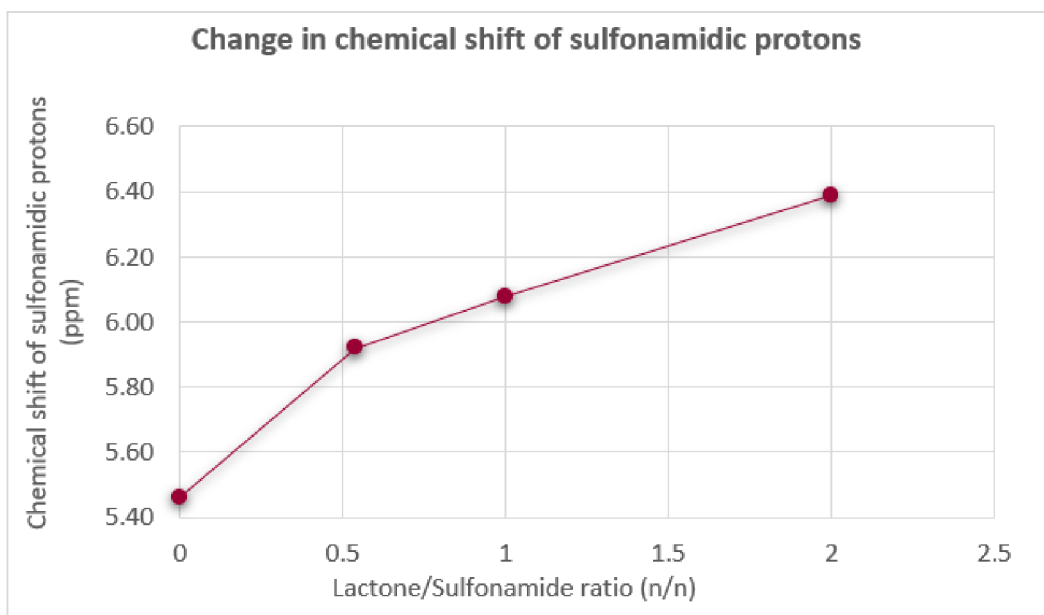
Graph 1- The change in chemical shift of α protonsGraph 2 – The change in chemical shift of sulfonamidic *CatA* protons

In the second case, where phenylglycinol derivative **CatB** was used as a potential dual HBD catalyst, the change in chemical shifts of both potential HBD donors (NH and OH) of **CatB** was comparable ($\Delta\sigma = 0.46$ ppm for amide, $\Delta\sigma = 0.40$ ppm, respectively) (Table 16, Graph 3, Graph 4). Interestingly, the downfield shift of α protons of lactone **4-100**

($\Delta\sigma = 0.03$ ppm) was observed (Table 16, Graph 5). The value reported by Mikami,¹⁸¹ was however considerably bigger ($\Delta\sigma = 0.34$ ppm for **4-102**).

Table 16 - Change in chemical shift of sulfonamide and lactone protons

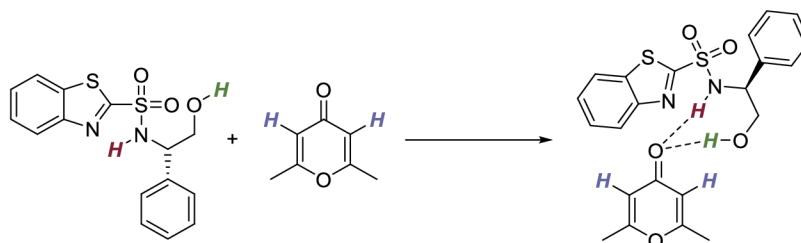

Entry	lactone/CatB(n/n)	ppm (NH)	ppm (OH)	ppm (CH)
1	0	6,53	3,01	6.05
2	0,5	6,69	3,21	6.09
3	1	6,89	3,41	6.08
4	2	7,2	3,7	6.0430
5	3	7,41	3,88	6.05

Graph 3 – The change in chemical shift of sulfonamidic CatB protons

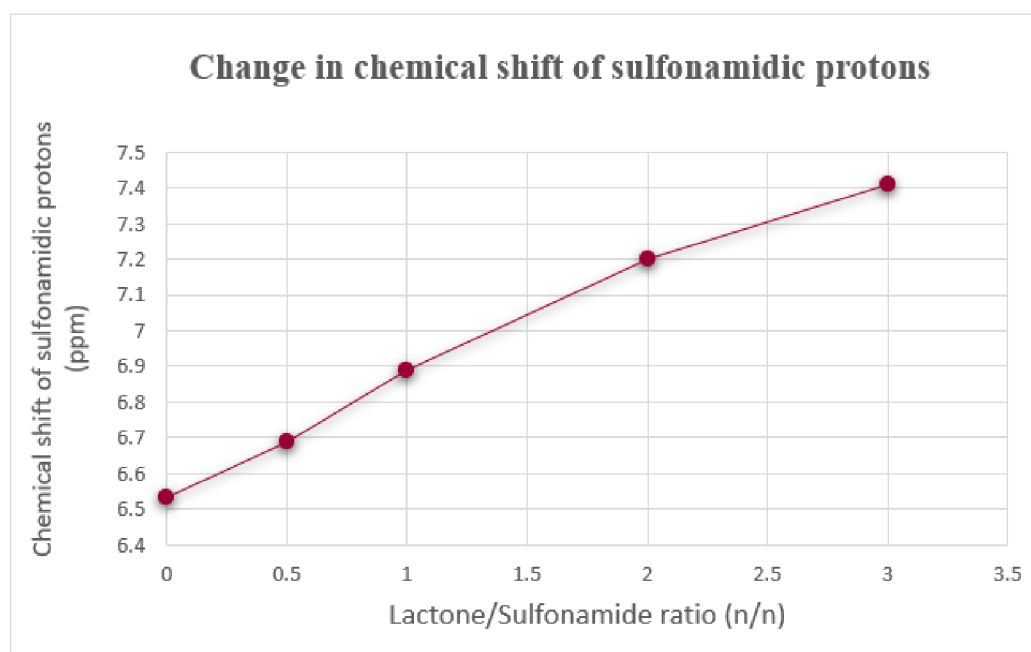

Graph 4 – The change in chemical shift of OH protons of CatB

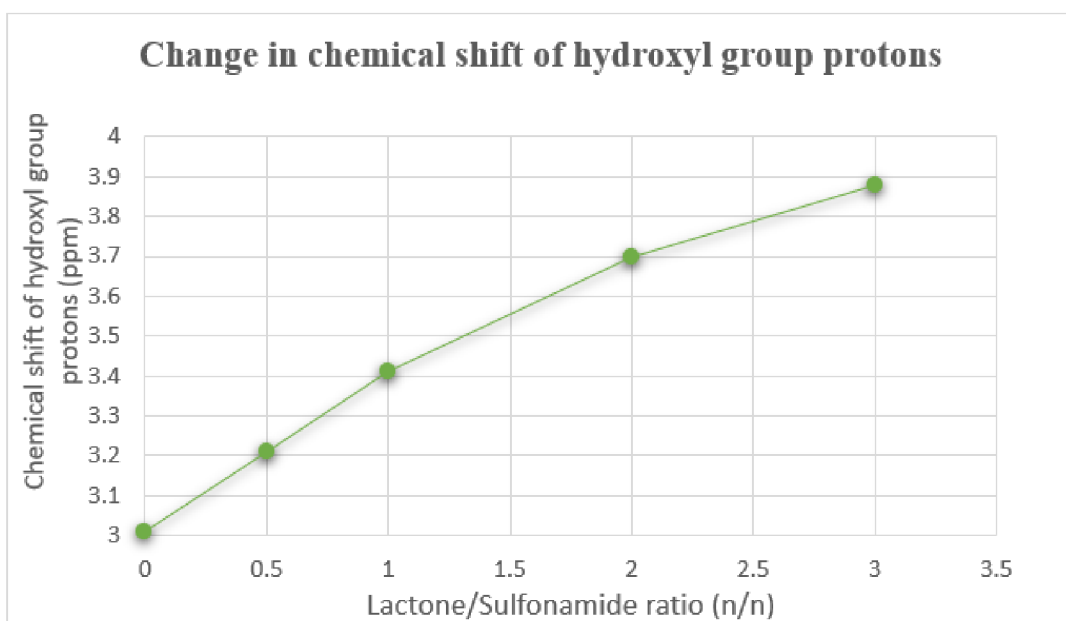
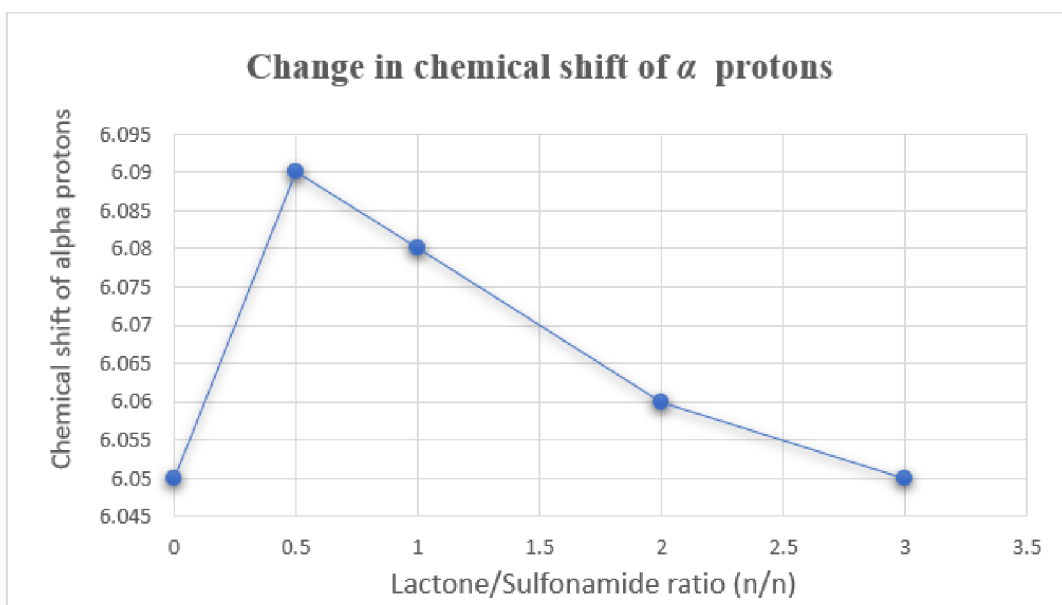
Graph 5 - The change in chemical shift of α protons 4-100

4.4.2.1 Preliminary screening of potential catalytic activity

Eventhough, the ^1H NMR experiments suggested weak interaction between sulfonamidic hydrogens and the lactone substrates, we anyway decided to test **CatA-D** as HBD catalysts under several reaction conditions. For our screening, four sulfonamides were chosen due to their possible HBD mono, di, multiple donation possibility (Figure 21).¹⁷⁵

Figure 21 – Selected HBD catalyst used in the HBD-catalysis screening

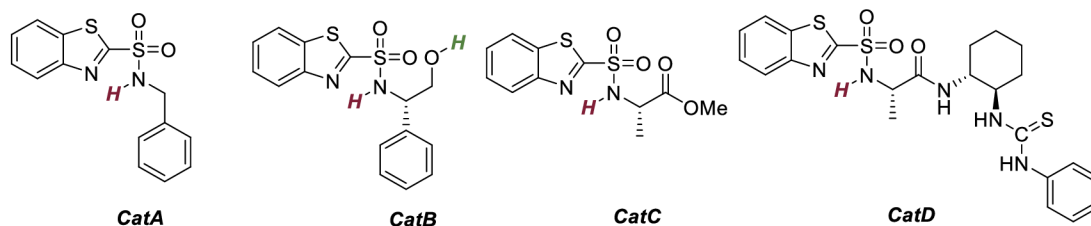

(Hetero)Diels-Alder reaction

As a first evaluated reaction were Diels-Alder reactions of Danishefski diene **4-103** with activated olefins **4-104** (Scheme 91). However, no reaction was observed under tested reaction conditions.^{179,177}

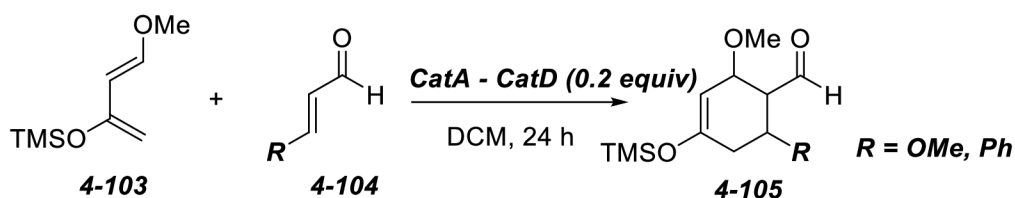

Scheme 91 – Evaluation of CatA-D in Diels-Alder reaction of Danishefski diene 4-103 with olefin

Next, we focused on the hetero Diels-Alder reaction of Danishefski diene **4-103** with ketohemiacetal **4-106** (Scheme 92). This particular reaction was also described by Mikami.¹⁸¹ In this original protocol, the **4-107** was obtained in 30 mins at $-78\text{ }^{\circ}\text{C}$ (84 % ee). However, in our case, the best yields when **CatB** was used and the reaction took 5 h at rt and unfortunately gave the desired product **4-107** in 51:49 e.r. Other catalyst proved to be inefficient.

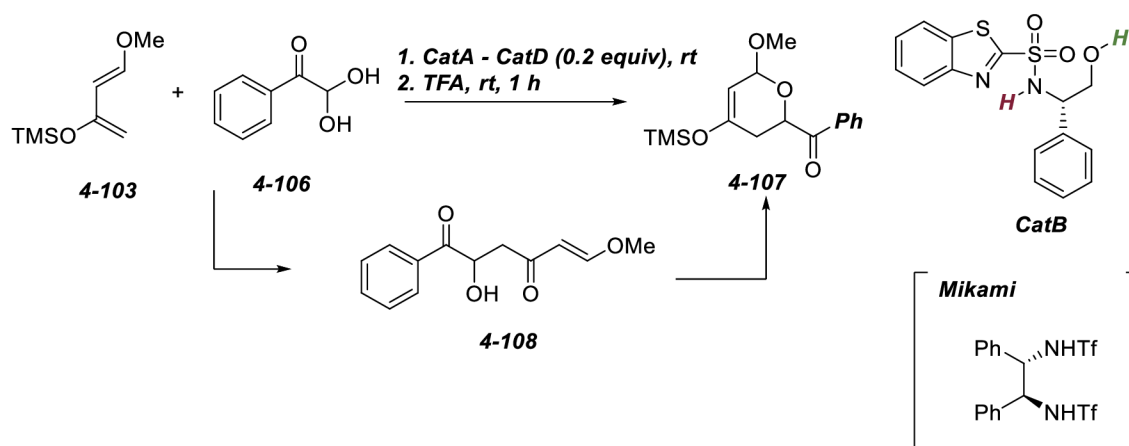

Scheme 92 – Evaluation of HBD catalysis in Diels-Alder reaction

Mukuyama aldol reaction

HBD catalysis is also often applied in the context of Mukuyama aldol reaction. We screened all four catalysts **CatA-D** in different solvents and conditions. Unfortunately, no reaction was observed in all attempted cases (Scheme 93/Scheme 93).

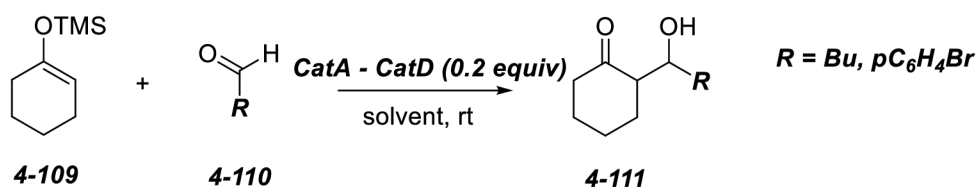

Scheme 93 – Mukuyama-aldol reaction

Aza-aldol reaction

Similarly, aza aldol reaction is very often catalysed by HBD catalyst. In this case we decided to test only **CatB**. Only low conversion of the imine **4-112** were observed during the reaction. These results showed significantly lower conversions when compared to original reports. Own catalyst **CatB** provided the product **4-113** in significantly lower yield and syn/anti selectivity (Table 17).

Table 17 – The role of catalyst on Aza-aldol reaction

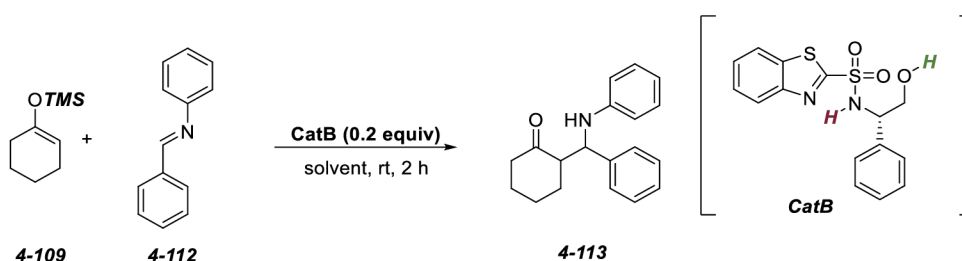

Entry	Cat	Solvent	NMR yield ^{a)} (syn/anti) ^{b)}
1	CatB	DCM	17% (2:1..syn/anti)
2	CatB	MeCN	27 % (2:1 syn/anti)
3	-	MeCN	50 % (10:1, syn/anti)

a) Yield based on ¹H NMR spectra with Me₂SO₂ as the standard

b) based on the ¹H NMR spectra of the crude reaction mixture

Acetal formation

Next we focused on the use of HBD catalysts as specific acetal **4-116** formation activators. Our approach was based on the work of Pápai et al.¹⁸² who developed thiourea catalysts **4-117** for acetal formation. Interestingly, with help of DFT calculations they proposed that in this particular case, thiourea catalyst **4-117** is presumably active as a

Bronsted acidic catalyst. In addition, it was shown that BA mechanism does not require parallel orientation of N-H bond. Observations that should allow our sulfonamides to act as mono HB donors (Scheme 94).

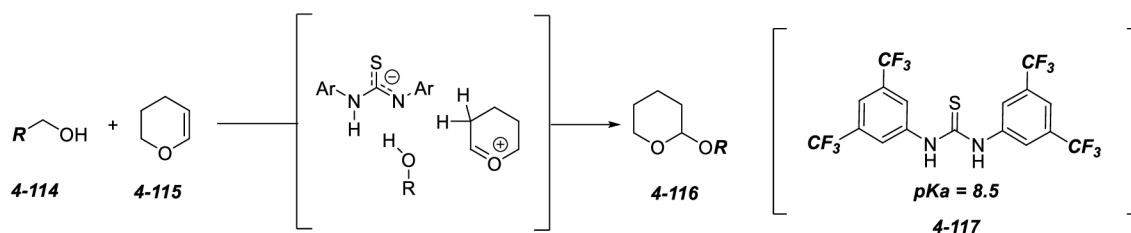

Scheme 94 – The mode of action of thiourea on hydroxyl group protection

Unfortunately, our screening of **CatA-D** catalyst showed no reactivity progress towards the acetal **4-116** formation. On the other hand, PPTS as a catalyst proved to be active (Table 19, Table 18).

Table 19 – Conversion of reactions catalyzed by BT sulfonamides (THP)

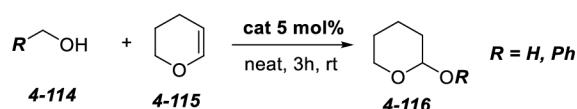
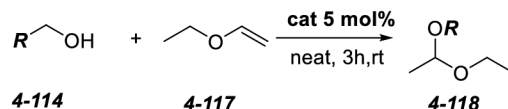

Table 18 – Conversion of reaction catalyzed by BT sulfonamides (Ethyl vinyl ether)



Entry	Cat	Conversion ^{a)}
1	CatA	< 5 %
2	CatB	< 5 %
3	CatC	< 5 %
4	CatD	< 5 %
5	PPTS	46 %

Entry	Cat	Conversion ^{a)}
1	CatA	< 5 %
2	CatB	< 5 %
3	CatC	< 5 %
4	CatD	< 5 %
5	PPTS	65 %

a) based on the ¹H NMR spectra of the crude reaction mixture

After all those rather unsuccessful applications, we finally attempted to use our BT-sulfonamides as co-catalysts. We expect that the addition of the **CatB-F** could increase the reaction rate and hopefully also the enantioselectivity of the targeted transformation. As a starting point we selected the addition of aldehyde **4-119** to succinimide **4-120** that is catalyzed by Hayashi-Jorgensen catalyst¹⁸³. Even though, this reaction was reported to give 99 % yield (dr = 8:1 and >95 ee). The reaction time was rather long (7 days). Our hypothesis was that if **CatB-F** is added into the reaction mixture, the reaction rate will increase, and the desired product will be formed in shorter

reaction time. The important feature of the additive **CatB-F** should be its selective activation of succinimide **4-120** while the Hayashi-Jorgensen catalysts will remain untouched (no deactivation via protonation). Gladly, our concept proved to be correct and it was observed that expected product **4-121** was observed in the reaction mixture already after 90 minutes (reactions were performed in NMR tube). In this particular case, it was shown that **CatB** was the most efficient co-catalyst for this reaction, causing 51% conversion already after 90 minutes. All remaining BT-sulfonamides also increase the rate of the reaction, however in lower magnitude. Finally, it should be pointed out, that the use of BT-sulfonamides as (co)catalysts in HBD catalysis seems to be very promising concept and this Thesis is just a first “shot” of this approach. I believe that my preliminary results gathered in this subchapter will serve as the starting point for the HBD catalysis development (Table 20).

Table 20 – Use of BT-sulfonamides as HBD co-catalysts in the Michael-type reactions

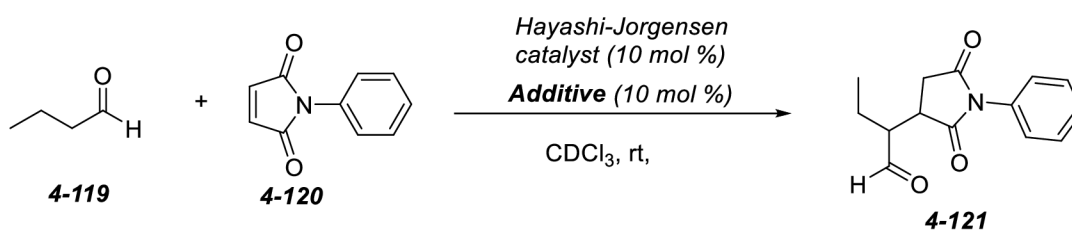

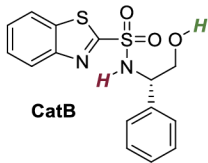
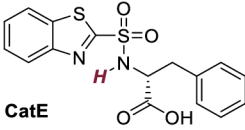
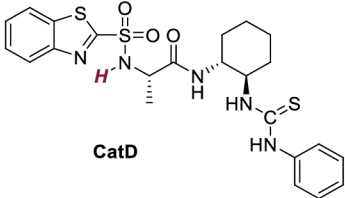
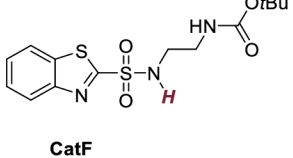
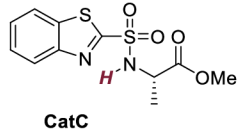
Additive (10 mol%)	Conversion (90 minutes ^{a)})	Additive (10 mol%)	Conversion (90 minutes ^{a)})
	52 %		18 %
	16 %		15 %
	11 %	NO ADDITIVE	< 10 %

a) based on the ¹H NMR spectra of the crude reaction mixture

b) reaction carried out in the NMR tube

4.5 Boehmenans – Neolignans of benzofurane family

4.5.1 Boehmenans – an introduction

Our long-time interest in plant secondary metabolites (neolignans) is driven by Boehmenans synthesis **4-122**. These neolignan compounds that are structurally similar to dehydrodiconiferyl alcohol glucoside (DCG) **4-123** posses interesting biological activity (Figure 22).¹⁸⁴ Boehmenans are natural compounds used in the traditional chinese medicine that can be isolated from the core of Kenaf,^{185, 186} as well as from *Durio carinatus a oxleyanus*,¹⁸⁷ *Durio zibenthinus*, *Helicteres hursuta*, *Sambucus adnata*, *Hibiscus ficulneus*.¹⁸⁸

Figure 22– A) Structure of Boehmenans isolated from higher plants B) DCG structure

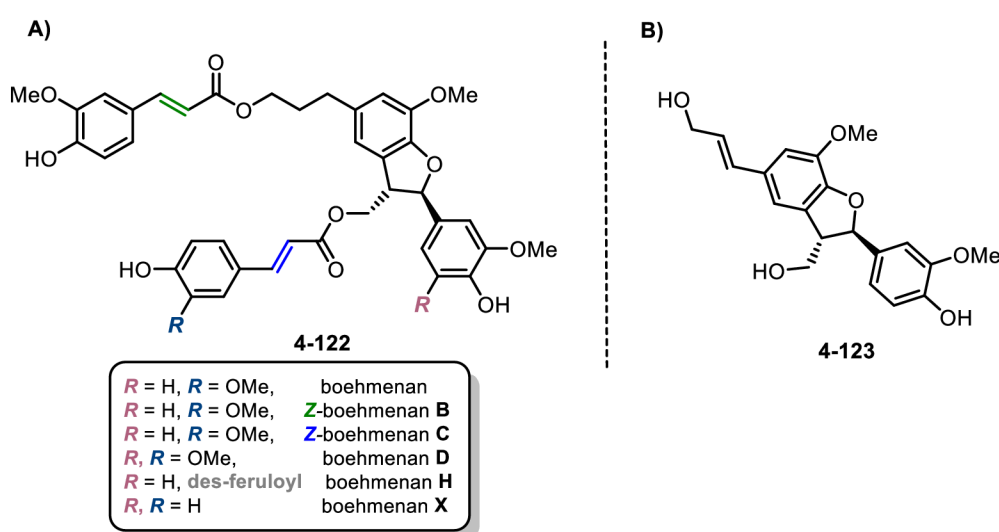

4.5.2 Biological activity

In recent years, the biological activity of Boehmenans were studied for their impact on regulation of Wnt/ β -catenin signaling pathway.^{188,189} Recently, it was also reported that anti-cancer properties of Boehmenans is caused by modulation of mitochondrial and epidermal EGFR signaling pathways.¹⁹⁰ It is important to note that all biological assesment was done on the compounds that came from the plan extracts. The only reported synthesis of Boehmenan (8 steps, 8% overall yield) reffered to *rac*-boehmenan **4-122**, that was not used in biological studies.

4.5.3 Retrosynthesis

Our goal was to developed general applicable synthesis of Boehmenan-like structures, that would allow us to prepare not only Boehmenans, but also their derivatives. From retro synthetic point of view, the sequence can be divided into three parts. Two easily accessible phenylpropanoid derivatives (acids) **4-125**, and a benzofurane core **4-124**. The synthesis of the

“core” fragment is the key part of the whole synthesis. The main aim of the project is to develop novel synthetic approach towards neolignan core of Boehmenan **4-122** that would allow us to modify each aromatic ring of the skelet prior the benzofurane formation. This approach thus eliminates the use of homodimeric approach, so common for the synthesis of neolignan-like compounds (Scheme 95).

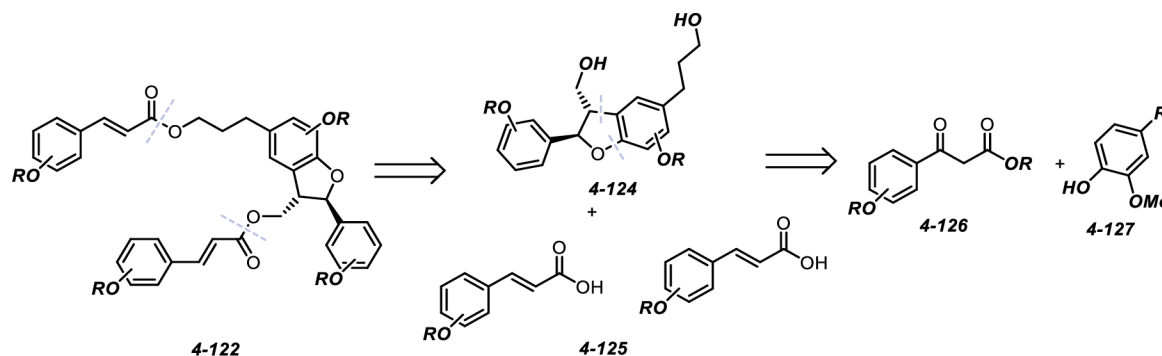

Scheme 95 – Retrosynthesis of Boehmenans

4.5.3.1 Neolignan core formation

As the benzofurane heterocycle **4-124** is the key building block of Boehmenan neolignan family, our goal was to investigate and develop general route towards such skeleton **4-128**. As was described in the theoretical part, the common preparations of neolignan-like derivatives with benzofuran core is based on biomimetic homocoupling (radical) approach. As it is obvious from its name, this method allows only the synthesis of benzofuranes with the same structural motive in aromatic rings **4-128**. Our aim was to design modular approach for the Boehmenan family (Scheme 96) in order to synthesize “non-symmetrical” benzofuran cores **4-129**.

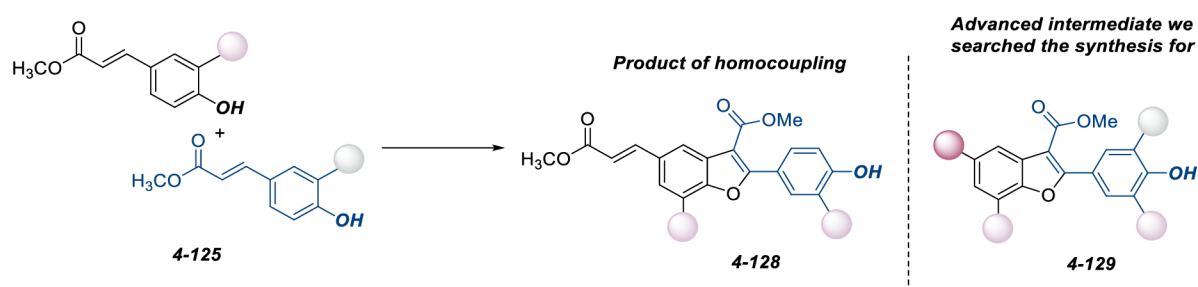

Scheme 96 – (A) General scheme for homocoupling reaction and (B) targeted modulable skeleton

4.5.4 Homocoupling approach

First, the literature report-based metal-catalysed and enzymatic homocoupling was attempted. Using this approach, we wished to evaluate the literature reports and also to prepare racemic substrates that would serve as the standards for the synthesis development. Attempted reaction

conditions yielded dihydrobenzofurans **4-132** in good selectivity, albeit in poor yields (Table 21).

Table 21– Screening of homocoupling conditions

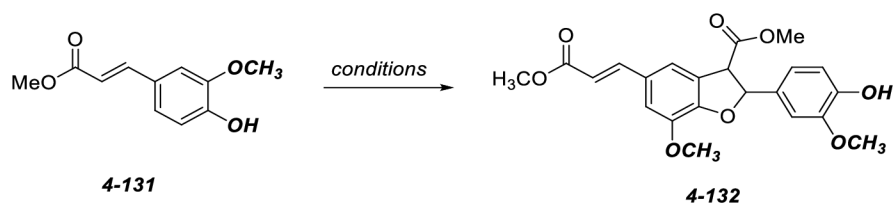

Entry	Conditions	Yield ^{a)}	Trans/cis
1	K ₃ [Fe(CN) ₆] (2.1 equiv), DCM/CHCl ₃ 1:9, rt	22	82:18
2	Ag ₂ O (2.1 equiv), acetone/benzene 3:1, rt	28	91:9
3	Ag ₂ O (2.1 equiv), DCM, rt	7	89:11
4	Ag ₂ O (2.1 equiv), DCM/H ₂ O, 1:1, rt	13	92:8
5	HRP, 1 M aq. H ₂ O ₂ (10 equiv), phosphate buffer pH = 7.3	7	81:19
6	HRP, 1 M aq. H ₂ O ₂ (10 equiv), phosphate buffer pH = 4.5	11	71:29
7	HRP, 1 M aq. H ₂ O ₂ (10 equiv), phosphate buffer pH = 7.3	10	89:11

a) refers to isolated yield after the flash column chromatography

4.5.5 Cross dehydrogenative coupling (CDC)

Along with the biomimetic approach, CDC coupling that is suitable for divergent synthesis of benzofurane **4-135** was attempted. As a starting point, we used the work of Guo et al. who combined the use of Fe^{III}/oxidant to promote reactions of substituted phenols **4-133** and 1,3 ketoesters **4-134**.¹⁹¹ The authors describes the double role of iron catalyst. Firstly, it catalyses the one-electron CDC coupling followed by its Lewis acid activity in condensation step (Scheme 97).

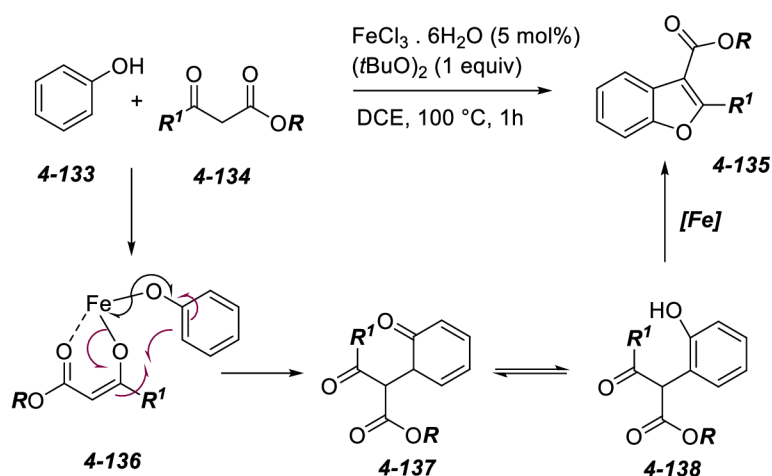

Scheme 97 – Reaction mechanism of CDC coupling

In our approach we explored several reaction conditions developed by Guo¹⁹¹ and Parnes¹⁹² and applied them to the CDC coupling of methyl ferulate **4-139** and ketoesters **4-140**. Unfortunately, the desired product **4-141** was obtained only in low yields. The best result (36 %) was obtained when the combination of Fe³⁺/DTBP was used (Table 22, Entry 3).¹⁹³

Table 22– Optimization of CDC reaction using methyl ferulate and ketoester

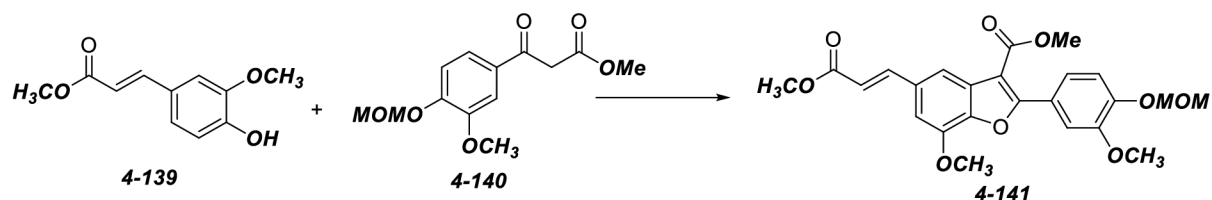

Entry	Conditions	Yield(%) ^(a)
1	FeCl ₃ (10 mol%), 2,2'-dipyridine (5 mol%) DTBP (2.5 equiv), DCE, 70 °C	23
2	FeCl ₃ (10 mol%), 2,2'-dipyridine (10 mol%) DTBP (2.5 equiv), DCE, 70 °C	11
3	FeCl ₃ (10 mol%), NHPI (5 mol%) DTBP (2.5 equiv), DCE, 70 °C	36
4	FeCl ₃ (10 mol%), NHPI (10 mol%) DTBP (2.5 equiv), DCE, 70 °C	12
5	FeCl ₃ (10 mol%), DTBP (2.5 equiv), DCE, 70 °C	5
6	FeCl ₃ (10 mol%), atmospheric air DCE, 70 °C	14

a) refers to pure isolated compound after the flash column chromatography

Since the only difference between the literature reports^{191,192} and our substrate was in the presence of methoxy group in *ortho* position with respect to phenolic group **4-142**, we were wondering if the CDC coupling step proceeds in concerted or stepwise manner. Since radical reactions usually proceeds in stepwise manner, we can presume that the formation of radical in *ortho* position with respect with to the starting phenol group **4-142a** is favoured due to the presence of unsaturated chain. The presence of methoxy group on the other hand might too much stabilize generated radical that further undergoes slow degradation instead of the desired coupling reaction (Scheme 98).

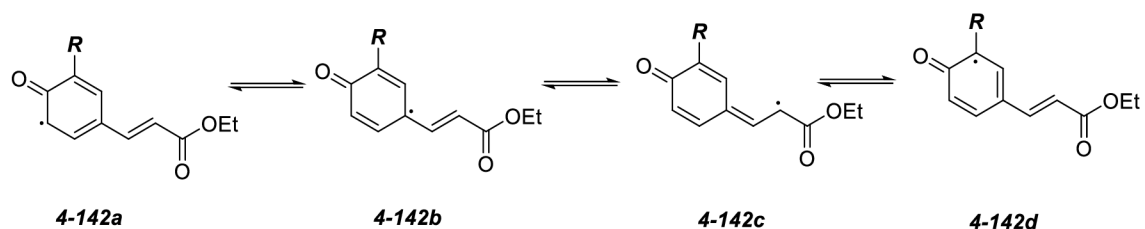

Scheme 98 – Free radical stabilization

Further extension of developed conditions to other ferulic acid derivatives showed that unsubstituted and *para* substituted phenols gives the desired products in acceptable yields (Table 23, Entry 1, 2, 3). Additionally, substitution on the phenol ring **4-144** led to the degradation of starting material and yielded no products (Table 23, Entry 4 - 10). The same results were observed if additional substituent was introduced to the ketoester aromatic ring **4-143** (Table 23, Entry 6 - 10)

Table 23– Scope of CDC coupling

Conversion			Conversion				
Entry	Ketoester	Phenol	Entry	Ketoester	Phenol		
1			96 %	6			< 5%
2			30%	7			< 5%
3			40 %	8			< 5%
4			< 5%	9			< 5%
5			< 5%	10			< 5%

Unfortunately, Boehmenan neolignans possess several electron-donating substituents on both aromatic rings. Thus, CDC coupling-based approach to Boehmenan family of neolignans proved to be unsuitable. Different type of the (retro)synthesis thus has to be found if targeted molecules should be successfully prepared.

5 Summary and perspective

In the presented Thesis, I have shown the detailed investigation of BT-sulfonamide preparation. Three main synthetic approaches were successfully investigated, and scope and limitations of each method were evaluated. Obtained results established unique place of benzothiazole sulfonamide derivatives in the sulfonamidic family from the synthetic point of view together with their unique reactivity (Scheme 99). Unfortunately, the conditions we optimized for benzothiazolesulfonamidic moiety proved to be hardly transferable to other electron-poor heterocycles (pyrimidine, phenyltetrazole). The unique reactivity of these compounds are best reflected in very specific reaction conditions that had to be developed on well established reactions. The mild conditions required for its introduction along with chemoselective cleavage of benzothiazole sulfonyl moiety, open the door for its use as amino group protecting group that is suitable for late-stage modification. Unfortunately, we failed to find a robust reaction conditions for transition metal catalyzed reaction, since Buchwald-Hartwig coupling failed to give products at all and the scope of Chan-Lam coupling is very limited. Finally, preliminary data showed that Smiles rearrangement of BT-sulfonamides of aminoacids yield interesting α -quarternary center bearing heteroaryl aminoacids.

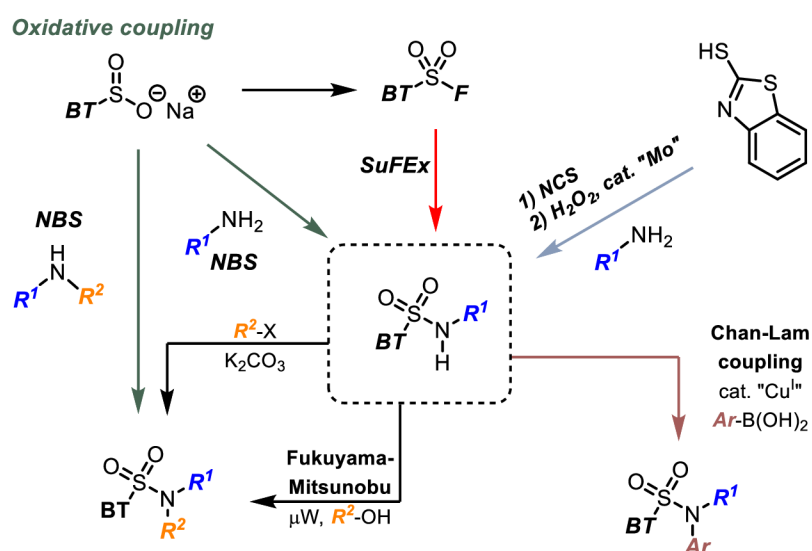

Scheme 99 – Overview of general routes to BT-sulfonamides

Next, we were interested in the use of BT-sulfonamides as HBD donors in organic synthesis. So far, only limited data were obtained, however, we failed to predict the use of these components as (thio)urea equivalents for organic catalysis. In this context, more work, has to be done, but it is believed, that a unique and readily available access to these HBD (co)catalysts is a good starting point for their further development and application. In addition, the pK_a values

of such HBD donor will be readily tunable by the changes both in BT-heteroaryl ring as well as by the changes in attached chains.

Despite the great potential of CDC coupling in the benzofurane synthesis, it was demonstrated that such approach fails in the case of Boehmenan-like compounds. Currently in our group we shifted our attention to transition metal-catalyzed transformations that might bring the solution to the desired modular synthesis approach, that will allow us to prepare huge chemical library of benzofurane derivatives suitable for further biological properties.

6 Literature

- (1) Bon, D. J. Y. D.; Kováč, O.; Ferugová, V.; Zálešák, F.; Pospíšil, J. One and Two-Carbon Homologation of Primary and Secondary Alcohols to Corresponding Carboxylic Esters Using β -Carbonyl BT Sulfones as a Common Intermediate. *J. Org. Chem.* **2018**, *83* (9), 4990–5001. <https://doi.org/10.1021/acs.joc.8b00112>.
- (2) Kováč, O.; Zálešák, F.; J.-Y. D. Bon, D.; Roiser, L.; V. Baar, L.; Waser, M.; Pospíšil, J. Trisubstituted Highly Activated Benzo[d]thiazol-2-yl-sulfone-Containing Olefins as Building Blocks in Organic Synthesis. *J. Org. Chem.* **2020**, *85* (11), 7192–7206. <https://doi.org/10.1021/acs.joc.0c00571>.
- (3) Konrádová, D.; Kozubíková, H.; Doležal, K.; Pospíšil, J. Microwave-Assisted Synthesis of Phenylpropanoids and Coumarins: Total Synthesis of Osthol. *European J. Org. Chem.* **2017**, *2017* (35), 5204–5213. <https://doi.org/https://doi.org/10.1002/ejoc.201701021>.
- (4) Eschenmoser, A.; Wintner, C. E. Natural product synthesis and vitamin B12. *Science* **1977**, *196* (4297), 1410–1420. <https://doi.org/10.1126/science.867037>.
- (5) Armaly, A. M.; DePorre, Y. C.; Groso, E. J.; Riehl, P. S.; Schindler, C. S. Discovery of Novel Synthetic Methodologies and Reagents during Natural Product Synthesis in the Post-Palytoxin Era. *Chem. Rev.* **2015**, *115* (17), 9232–9276. <https://doi.org/10.1021/acs.chemrev.5b00034>.
- (6) Overman, L. E. Molecular rearrangements in the construction of complex molecules. *Tetrahedron* **2009**, *65* (33), 6432–6446. <https://doi.org/https://doi.org/10.1016/j.tet.2009.05.067>.
- (7) Service, R. F. Race for Molecular Summits. *Science* **1999**, *285* (5425), 187. <https://doi.org/10.1126/science.285.5425.184>.
- (8) Khan, A. G.; Eswaran, S. V. Woodward's synthesis of vitamin B12. *Resonance* **2003**, *8* (6), 8–16. <https://doi.org/10.1007/BF02837864>.
- (9) Armstrong, R. W.; Beau, J. M.; Cheon, S. H.; Christ, W. J.; Fujioka, H.; Ham, W. H.; Hawkins, L. D.; Jin, H.; Kang, S. H. Total synthesis of palytoxin carboxylic acid and palytoxin amide. *J. Am. Chem. Soc.* **1989**, *111* (19), 7530–7533. <https://doi.org/10.1021/ja00201a038>.
- (10) Burns, N. Z.; Baran, P. S.; Hoffmann, R. W. Redox Economy in Organic Synthesis. *Angew. Chemie Int. Ed.* **2009**, *48* (16), 2854–2867. <https://doi.org/https://doi.org/10.1002/anie.200806086>.
- (11) Trost, B. M. The atom economy--a search for synthetic efficiency. *Science* **1991**, *254* (5037), 1471–1477. <https://doi.org/10.1126/science.1962206>.
- (12) Wender, P. A.; Verma, V. A.; Paxton, T. J.; Pillow, T. H. Function-Oriented Synthesis, Step Economy, and Drug Design. *Acc. Chem. Res.* **2008**, *41* (1), 40–49. <https://doi.org/10.1021/ar700155p>.

- (13) Zhao, C.; Rakesh, K. P.; Ravidar, L.; Fang, W.-Y.; Qin, H.-L. Pharmaceutical and medicinal significance of sulfur (SVI)-Containing motifs for drug discovery: A critical review. *Eur. J. Med. Chem.* **2019**, *162*, 679–734. <https://doi.org/https://doi.org/10.1016/j.ejmech.2018.11.017>.
- (14) Otten, H. Domagk and the development of the sulphonamides. *J. Antimicrob. Chemother.* **1986**, *17* (6), 689–690. <https://doi.org/10.1093/jac/17.6.689>.
- (15) Zhao, Y.; Shadrack, W. R.; Wallace, M. J.; Wu, Y.; Griffith, E. C.; Qi, J.; Yun, M.-K.; White, S. W.; Lee, R. E. Pterin–sulfa conjugates as dihydropteroate synthase inhibitors and antibacterial agents. *Bioorg. Med. Chem. Lett.* **2016**, *26* (16), 3950–3954. <https://doi.org/https://doi.org/10.1016/j.bmcl.2016.07.006>.
- (16) Fidahic, M.; Jelacic Kadic, A.; Radic, M.; Puljak, L. Celecoxib for rheumatoid arthritis. *Cochrane Database Syst. Rev.* **2017**, <https://doi.org/10.1002/14651858.CD012095.pub2>.
- (17) Blanke, C. D. Celecoxib with Chemotherapy in Colorectal Cancer. *Oncology (Williston Park)*. **2002**, *16*, 17–21.
- (18) Müller, N.; Myint, A.-M.; Krause, D.; Weidinger, E.; Schwarz, M. J. Anti-inflammatory treatment in schizophrenia. *Prog. Neuro-Psychopharmacology Biol. Psychiatry* **2013**, *42*, 146–153. <https://doi.org/https://doi.org/10.1016/j.pnpbp.2012.11.008>.
- (19) Na, K.-S.; Lee, K. J.; Lee, J. S.; Cho, Y. S.; Jung, H.-Y. Efficacy of adjunctive celecoxib treatment for patients with major depressive disorder: A meta-analysis. *Prog. Neuro-Psychopharmacology Biol. Psychiatry* **2014**, *48*, 79–85. <https://doi.org/https://doi.org/10.1016/j.pnpbp.2013.09.006>.
- (20) Ferguson, D. R.; Twite, B. R. Furosemide — Pharmacology and cellular mode of action. *Naunyn. Schmiedebergs. Arch. Pharmacol.* **1974**, *281* (3), 295–300. <https://doi.org/10.1007/BF00500598>.
- (21) Giles, A.; Foushee, J.; Lantz, E.; Gumina, G. Sulfonamide Allergies. *Pharmacy* . 2019. <https://doi.org/10.3390/pharmacy7030132>.
- (22) Yoshino, T.; Sono, M.; Yazumi, S. Usefulness of Sulfasalazine for Patients with Refractory-Ulcerative Colitis. *BMJ open Gastroenterol.* **2016**, *3* (1), <https://doi.org/10.1136/bmjgast-2016-000103>.
- (23) Büning, C.; Lochs, H. Conventional Therapy for Crohn’s Disease. *World J. Gastroenterol.* **2006**, *12* (30), 4794–4806. <https://doi.org/10.3748/wjg.v12.i30.4794>.
- (24) Smedegård, G.; Björk, J. Sulphasalazine: Mechanism of Action in Rheumatoid Arthritis. *Br. J. Rheumatol.* **1995**, *34*, 7–15.
- (25) Serrano-Martín, X.; Payares, G.; Mendoza-León, A. Glibenclamide, a Blocker of K + ATP Channels, Shows Antileishmanial Activity in Experimental Murine Cutaneous Leishmaniasis. *Antimicrob. Agents Chemother.* **2006**, *50* (12), 4214–4216. <https://doi.org/10.1128/AAC.00617-06>.

- (26) King, N. M.; Prabu-Jeyabalan, M.; Nalivaika, E. A.; Wigerinck, P.; de Béthune, M.-P.; Schiffer, C. A. Structural and Thermodynamic Basis for the Binding of TMC114, a Next-Generation Human Immunodeficiency Virus Type 1 Protease Inhibitor. *J. Virol.* **2004**, *78* (21), 12012–12021. <https://doi.org/10.1128/JVI.78.21.12012-12021.2004>.
- (27) Cox, V. C.; Zed, P. J. Once-Daily Cefazolin and Probenecid for Skin and Soft Tissue Infections. *Ann. Pharmacother.* **2004**, *38* (3), 458–463. <https://doi.org/10.1345/aph.1D251>.
- (28) Morra, V.; Davit, P.; Capra, P.; Vincenti, M.; Di Stilo, A.; Botrè, F. Fast gas chromatographic/mass spectrometric determination of diuretics and masking agents in human urine: Development and validation of a productive screening protocol for antidoping analysis. *J. Chromatogr. A* **2006**, *1135* (2), 219–229. <https://doi.org/https://doi.org/10.1016/j.chroma.2006.09.034>.
- (29) Ballatore, C.; Huryn, D. M.; Smith III, A. B.; Smith, A. B. Carboxylic Acid (Bio)Isosteres in Drug Design. *ChemMedChem* **2013**, *8* (3), 385–395. <https://doi.org/https://doi.org/10.1002/cmdc.201200585>.
- (30) K. Yee, Y.; R. Bernstein, P.; J. Adams, E.; J. Brown, F.; A. Cronk, L.; C. Hebbel, K.; P. Vacek, E.; D. Krell, R.; W. Snyder, D. A novel series of selective leukotriene antagonists: exploration and optimization of the acidic region in 1,6-disubstituted indoles and indazoles. *J. Med. Chem.* **2002**, *33* (9), 2437–2451. <https://doi.org/10.1021/jm00171a018>.
- (31) E. Uehling, D.; H. Donaldson, K.; N. Deaton, D.; E. Hyman, C.; E. Sugg, E.; G. Barrett, D.; G. Hughes, R.; Reitter, B.; K. Adkison, K.; E. Lancaster, M.; Synthesis and Evaluation of Potent and Selective β_3 Adrenergic Receptor Agonists Containing Acylsulfonamide, Sulfonylsulfonamide, and Sulfonylurea Carboxylic Acid Isosteres. *J. Med. Chem.* **2001**, *45* (3), 567–583. <https://doi.org/10.1021/jm0101500>.
- (32) Kwon, Y.; Song, J.; Lee, H.; Kim, E.-Y.; Lee, K.; Kook Lee, S.; Kim, S. Design, Synthesis, and Biological Activity of Sulfonamide Analogues of Antofine and Cryptopleurine as Potent and Orally Active Antitumor Agents. *J. Med. Chem.* **2015**, *58* (19), 7749–7762. <https://doi.org/10.1021/acs.jmedchem.5b00764>.
- (33) Dong, J.; Krasnova, L.; Finn, M. G.; Sharpless, K. B. Sulfur(VI) Fluoride Exchange (SuFEx): Another Good Reaction for Click Chemistry. *Angew. Chemie Int. Ed.* **2014**, *53* (36), 9430–9448. <https://doi.org/10.1002/anie.201309399>.
- (34) Patai, S.; Rappoport, Z.; Stirling, C. *Sulphones and Sulphoxides (1988)*; Patai, S., Rappoport, Z., Stirling, C.,; John Wiley & Sons, Ltd: Chichester, UK, 1988. <https://doi.org/10.1002/0470034386>.
- (35) A. Takacs, G. Heats of formation and bond dissociation energies of some simple sulfur- and halogen-containing molecules. *J. Chem. & Eng. Data* **2002**, *23* (2), 174–175. <https://doi.org/10.1021/je60077a020>.
- (36) Ciuffarin, E.; Senatore, L.; Isola, M. Nucleophilic substitution at four-co-ordinate sulphur. Mobility of the leaving group. *J. Chem. Soc. Perkin Trans. 2* **1972**, *4*, 468. <https://doi.org/10.1039/p29720000468>.

- (37) Kim, J.-G.; Jang, D. O. A Convenient, One-Pot Procedure for the Preparation of Acyl and Sulfonyl Fluorides Using Cl₃CCN, Ph₃P, and TBAF(t-BuOH)₄. *Synlett* **2010**, 2010 (20), 3049–3052. <https://doi.org/10.1055/s-0030-1259051>.
- (38) Brouwer, A. J.; Ceylan, T.; Linden, T. van der; Liskamp, R. M. J. Synthesis of β-aminoethanesulfonyl fluorides or 2-substituted taurine sulfonyl fluorides as potential protease inhibitors. *Tetrahedron Lett.* **2009**, 50 (26), 3391–3393. <https://doi.org/https://doi.org/10.1016/j.tetlet.2009.02.130>.
- (39) Tang, L.; Yang, Y.; Wen, L.; Yang, X.; Wang, Z. Catalyst-free radical fluorination of sulfonyl hydrazides in water. *Green Chem.* **2016**, 18 (5), 1224–1228. <https://doi.org/10.1039/C5GC02755A>.
- (40) Banks, R. E.; Besheesh, M. K.; Mohialdin-Khaffaf, S. N.; Sharif, I. N-Halogeno compounds. Part 18. 1-Alkyl-4-fluoro-1,4-diazoniabicyclo[2.2.2]octane salts: user-friendly site-selective electrophilic fluorinating agents of the N-fluoroammonium class. *J. Chem. Soc. Perkin Trans. 1* **1996**, 16, 2069 <https://doi.org/10.1039/P19960002069>.
- (41) Davies, A. T.; Curto, J. M.; Bagley, S. W.; Willis, M. C. One-pot palladium-catalyzed synthesis of sulfonyl fluorides from aryl bromides. *Chem. Sci.* **2017**, 8 (2), 1233–1237. <https://doi.org/10.1039/C6SC03924C>.
- (42) L. Tribby, A.; Rodríguez, I.; Shariffudin, S.; D. Ball, N. Pd-Catalyzed Conversion of Aryl Iodides to Sulfonyl Fluorides Using SO₂ Surrogate DABSO and Selectfluor. *J. Org. Chem.* **2017**, 82 (4), 2294–2299. <https://doi.org/10.1021/acs.joc.7b00051>.
- (43) W. Wright, S.; N. Hallstrom, K. A Convenient Preparation of Heteroaryl Sulfonyl Fluorides from Heteroaryl Thiols. *J. Org. Chem.* **2006**, 71 (3), 1080–1084. <https://doi.org/10.1021/jo052164+>.
- (44) Kirihaara, M.; Naito, S.; Nishimura, Y.; Ishizuka, Y.; Iwai, T.; Takeuchi, H.; Ogata, T.; Hanai, H.; Kinoshita, Y.; Kishida, M.; وآخ. Oxidation of disulfides with electrophilic halogenating reagents: concise methods for preparation of thiosulfonates and sulfonyl halides. *Tetrahedron* **2014**, 70 (14), 2464–2471. <https://doi.org/https://doi.org/10.1016/j.tet.2014.02.013>.
- (45) Laudadio, G.; de A. Bartolomeu, A.; M. H. M. Verwijlen, L.; Cao, Y.; T. de Oliveira, K.; Noël, T. Sulfonyl Fluoride Synthesis through Electrochemical Oxidative Coupling of Thiols and Potassium Fluoride. *J. Am. Chem. Soc.* **2019**, 141 (30), 11832–11836. <https://doi.org/10.1021/jacs.9b06126>.
- (46) W. Larson, J.; B. McMahon, T. Gas-phase bifluoride ion. An ion cyclotron resonance determination of the hydrogen bond energy in fluoride ion (FHF⁻) from gas-phase fluoride transfer equilibrium measurements. *J. Am. Chem. Soc.* **2002**, 124 (21), 5848–5849. <https://doi.org/10.1021/ja00385a077>.
- (47) Davies, W.; Dick, J. H. CCLXXXVI.—Aromatic sulphonyl fluorides. A convenient method of preparation. *J. Chem. Soc.* **1931**, 2104–2109. <https://doi.org/10.1039/JR9310002104>.

- (48) R. Bebernitz, G.; D. Aicher, T.; L. Stanton, J.; Gao, J.; S. Shetty, S.; C. Knorr, D.; J. Strohschein, R.; Tan, J.; J. Brand, L.; Liu, C.; Anilides of (R)-Trifluoro-2-hydroxy-2-methylpropionic Acid as Inhibitors of Pyruvate Dehydrogenase Kinase. *J. Med. Chem.* **2000**, *43* (11), 2248–2257. <https://doi.org/10.1021/jm0000923>.
- (49) Toulgoat, F.; R. Langlois, B.; Médebielle, M.; Sanchez, J.-Y. Efficient Preparation of New Fluorinated Lithium and Ammonium Sulfonimides. *J. Org. Chem.* **2008**, *73* (14), 5613–5616. <https://doi.org/10.1021/jo800272q>.
- (50) Mukherjee, P.; Woroch, C. P.; Cleary, L.; Rusznak, M.; Franzese, R. W.; Reese, M. R.; Tucker, J. W.; Humphrey, J. M.; Etuk, S. M.; Kwan, S. C.; Sulfonamide Synthesis via Calcium Triflimide Activation of Sulfonyl Fluorides. *Org. Lett.* **2018**, *20* (13), 3943–3947. <https://doi.org/10.1021/acs.orglett.8b01520>.
- (51) Dondoni, A.; Marra, A. SuFEx: a metal-free click ligation for multivalent biomolecules. *Org. Biomol. Chem.* **2017**, *15* (7), 1549–1553. <https://doi.org/10.1039/C6OB02458K>.
- (52) Dorogov, M. V.; Filimonov, S. I.; Kobylinsky, D. B.; Ivanovsky, S. A.; Korikov, P. V.; Soloviev, M. Y.; Khahina, M. Y.; Shalygina, E. E.; Kravchenko, D. V.; Ivachtchenko, A. V. A Convenient Synthesis of Novel 3-(Heterocyclisulfonyl)Propanoic Acids and Their Amide Derivatives. *Synthesis (Stuttg.)*. **2004**, *2004* (18), 2999–3004. <https://doi.org/10.1055/s-2004-834888>.
- (53) Nie, Z.; Perretta, C.; Lu, J.; Su, Y.; Margosiak, S.; S. Gajiwala, K.; Cortez, J.; Nikulin, V.; M. Yager, K.; Appelt, K.; Structure-Based Design, Synthesis, and Study of Potent Inhibitors of β -Ketoacyl-acyl Carrier Protein Synthase III as Potential Antimicrobial Agents. *J. Med. Chem.* **2005**, *48* (5), 1596–1609. <https://doi.org/10.1021/jm049141s>.
- (54) Mallireddigari, M. R.; Pallela, V. R.; Reddy, E. P.; Reddy, M. V. R. Sequential Reduction and Dehydration of Phenacyl-(E)-Styryl Sulfones to Unsymmetrical (E,E)-Bis(Styryl) Sulfones. *Synthesis (Stuttg.)*. **2005**, *2005* (20), 3639–3643. <https://doi.org/10.1055/s-2005-918450>.
- (55) Kellogg, R. M.; Nieuwenhuijzen, J. W.; Pouver, K.; Vries, T. R.; Broxterman, Q. B.; Grimbergen, R. F. P.; Kaptein, B.; Crois, R. M. La; de Wever, E.; Zwaagstra, K.; Dutch Resolution: Separation of Enantiomers with Families of Resolving Agents. A Status Report. *Synthesis (Stuttg.)*. **2003**, *2003* (10), 1626–1638. <https://doi.org/10.1055/s-2003-40508>.
- (56) M. Aquino, A.; J. Abelt, C.; L. Berger, K.; M. Darragh, C.; E. Kelley, S.; V. Cossette, M. Synthesis and photochemistry of some anthraquinone-substituted .beta.-cyclodextrins. *J. Am. Chem. Soc.* **2002**, *112* (15), 5819–5824. <https://doi.org/10.1021/ja00171a022>.
- (57) Wang, Y.; S. Guziec, F. A Convenient Reductive Deamination (Hydrodeamination) of Aromatic Amines. *J. Org. Chem.* **2001**, *66* (25), 8293–8296. <https://doi.org/10.1021/jo010681w>.
- (58) Serpier, F.; Brayer, J.-L.; Folléas, B.; Darses, S. Access to Polyfunctionalized Chiral Piperidines through Enantioselective Addition–Carbocyclization Cascade Reaction Catalyzed by a Rhodium(I)–Diene Complex. *Org. Lett.* **2015**, *17* (21), 5496–5499. <https://doi.org/10.1021/acs.orglett.5b02858>.

- (59) Matsuoka, J.; Kumagai, H.; Inuki, S.; Oishi, S.; Ohno, H. Construction of the Pyrrolo[2,3-d]carbazole Core of Spiroindoline Alkaloids by Gold-Catalyzed Cascade Cyclization of Ynamide. *J. Org. Chem.* **2019**, *84* (14), 9358–9363. <https://doi.org/10.1021/acs.joc.9b01149>.
- (60) Akin Kazancioglu, E.; Senturk, M. Synthesis of N-phenylsulfonamide derivatives and investigation of some esterase enzymes inhibiting properties. *Bioorg. Chem.* **2020**, *104*, 104279. <https://doi.org/10.1016/j.bioorg.2020.104279>.
- (61) Choi, E.; Lee, J.; Lee, S.; Song, B.-W.; Seo, H.-H.; Cha, M.-J.; Lim, S.; Lee, C.; Song, S.-W.; Han, G.; Potential therapeutic application of small molecule with sulfonamide for chondrogenic differentiation and articular cartilage repair. *Bioorg. Med. Chem. Lett.* **2016**, *26* (20), 5098–5102. <https://doi.org/https://doi.org/10.1016/j.bmcl.2016.08.069>.
- (62) Waszkowycz, B.; M. Smith, K.; E. McGonagle, A.; M. Jordan, A.; Acton, B.; E. Fairweather, E.; A. Griffiths, L.; M. Hamilton, N.; S. Hamilton, N.; R. Hitchin, J.; Cell-Active Small Molecule Inhibitors of the DNA-Damage Repair Enzyme Poly(ADP-ribose) Glycohydrolase (PARG): Discovery and Optimization of Orally Bioavailable Quinazolinedione Sulfonamides. *J. Med. Chem.* **2018**, *61* (23), 10767–10792. <https://doi.org/10.1021/acs.jmedchem.8b01407>.
- (63) Li, W.; Li, J.; Wu, Y.; Wu, J.; Hotchandani, R.; Cunningham, K.; McFadyen, I.; Bard, J.; Morgan, P.; Schlerman, F.; A Selective Matrix Metalloprotease 12 Inhibitor for Potential Treatment of Chronic Obstructive Pulmonary Disease (COPD): Discovery of (S)-2-(8-(Methoxycarbonylamino)dibenzo[b,d]furan-3-sulfonamido)-3-methylbutanoic acid (MMP408). *J. Med. Chem.* **2009**, *52* (7), 1799–1802. <https://doi.org/10.1021/jm900093d>.
- (64) Li, Y.; Hu, B.; Dong, W.; Xie, X.; Wan, J.; Zhang, Z. Visible Light-Induced Radical Rearrangement to Construct C–C Bonds via an Intramolecular Aryl Migration/Desulfonylation Process. *J. Org. Chem.* **2016**, *81* (16), 7036–7041. <https://doi.org/10.1021/acs.joc.6b00735>.
- (65) Ji, J.; Liu, Z.; Liu, P.; Sun, P. Synthesis of sulfonamides via copper-catalyzed oxidative C–N bond cleavage of tertiary amines. *Org. Biomol. Chem.* **2016**, *14* (29), 7018–7023. <https://doi.org/10.1039/C6OB01208F>.
- (66) Mulina, O. M.; Ilovaisky, A. I.; Terent'ev, A. O. Oxidative Coupling with S–N Bond Formation. *European J. Org. Chem.* **2018**, *2018* (34), 4648–4672. <https://doi.org/10.1002/ejoc.201800838>.
- (67) Zhao, J.; Xu, J.; Chen, J.; Wang, X.; He, M. Metal-free oxidative coupling of amines with sodium sulfinates: a mild access to sulfonamides. *RSC Adv.* **2014**, *4* (110), 64698–64701. <https://doi.org/10.1039/C4RA13454K>.
- (68) Buathongjan, C.; Beukeaw, D.; Yotphan, S. Iodine-Catalyzed Oxidative Amination of Sodium Sulfinates: A Convenient Approach to the Synthesis of Sulfonamides under Mild Conditions. *European J. Org. Chem.* **2015**, *2015* (7), 1575–1582. <https://doi.org/10.1002/ejoc.201403531>.

- (69) Wu, S.-X.; Zhang, Y.-K.; Shi, H.-W.; Yan, J. Iodine-catalyzed N-sulfonylation of benzotriazoles with sodium sulfinates under mild conditions. *Chinese Chem. Lett.* **2016**, *27* (9), 1519–1522. <https://doi.org/https://doi.org/10.1016/j.ccllet.2016.03.024>.
- (70) Lai, J.; Chang, L.; Yuan, G. I₂/TBHP Mediated C–N and C–H Bond Cleavage of Tertiary Amines toward Selective Synthesis of Sulfonamides and β -Arylsulfonyl Enamines: The Solvent Effect on Reaction. *Org. Lett.* **2016**, *18* (13), 3194–3197. <https://doi.org/10.1021/acs.orglett.6b01412>.
- (71) Wu, S.; Zhang, Y.; Zhu, M.; Yan, J. One-Pot Synthesis of Sulfonamides from Sodium Sulfinates and Amines via Sulfonyl Bromides. *Synlett* **2016**, *27* (19), 2699–2704. <https://doi.org/10.1055/s-0036-1588298>.
- (72) Fu, L.; Bao, X.; Li, S.; Wang, L.; Liu, Z.; Chen, W.; Xia, Q.; Liang, G. Synthesis of sulfonamides from azoles and sodium sulfinates at ambient temperature. *Tetrahedron* **2017**, *73* (17), 2504–2511. <https://doi.org/https://doi.org/10.1016/j.tet.2017.03.038>.
- (73) Tang, X.; Huang, L.; Qi, C.; Wu, X.; Wu, W.; Jiang, H. Copper-catalyzed sulfonamides formation from sodium sulfinates and amines. *Chem. Commun.* **2013**, *49* (54), 6102–6104. <https://doi.org/10.1039/C3CC41249K>.
- (74) Zhang, W.; Xie, J.; Rao, B.; Luo, M. Iron-Catalyzed N-Arylsulfonamide Formation through Directly Using Nitroarenes as Nitrogen Sources. *J. Org. Chem.* **2015**, *80* (7), 3504–3511. <https://doi.org/10.1021/acs.joc.5b00130>.
- (75) Wang, X.; Yang, M.; Kuang, Y.; Liu, J.-B.; Fan, X.; Wu, J. Copper-catalyzed synthesis of sulfonamides from nitroarenes via the insertion of sulfur dioxide. *Chem. Commun.* **2020**, *56* (23), 3437–3440. <https://doi.org/10.1039/D0CC00721H>.
- (76) Beiginejad, H.; Nematollahi, D. Electrochemical Synthesis of Sulfonamide Derivatives Based on the Oxidation of 2,5-Diethoxy-4-Morpholinoaniline in the Presence of Arylsulfinic Acids. *J. Org. Chem.* **2014**, *79* (13), 6326–6329. <https://doi.org/10.1021/jo500812d>.
- (77) Jiang, Y.; Wang, Q.-Q.; Liang, S.; Hu, L.-M.; Daniel Little, R.; Zeng, C.-C. Electrochemical Oxidative Amination of Sodium Sulfinates: Synthesis of Sulfonamides Mediated by NH₄I as a Redox Catalyst. *J. Org. Chem.* **2016**, *81* (11), 4713–4719. <https://doi.org/10.1021/acs.joc.6b00615>.
- (78) Terent'ev, A. O.; Mulina, O. M.; Pirygach, D. A.; Syroeshkin, M. A.; Glinushkin, A. P.; Nikishin, G. I. Electrochemical synthesis of sulfonamides from arenesulfonohydrazides or sodium p-methylbenzenesulfinate and amines. *Mendeleev Commun.* **2016**, *26* (6), 538–539. <https://doi.org/https://doi.org/10.1016/j.mencom.2016.11.027>.
- (79) Shavnya, A.; B. Coffey, S.; D. Hesp, K.; C. Ross, S.; S. Tsai, A. Reaction of Alkyl Halides with Rongalite: One-Pot and Telescoped Syntheses of Aliphatic Sulfonamides, Sulfonyl Fluorides, and Unsymmetrical Sulfones. *Org. Lett.* **2016**, *18* (22), 5848–5851. <https://doi.org/10.1021/acs.orglett.6b02894>.

- (80) Rahimi, A.; Habibi, D.; Rostami, A.; Ali Zolfigol, M.; Mallakpour, S. Laccase-catalyzed, aerobic oxidative coupling of 4-substituted urazoles with sodium arylsulfonates: Green and mild procedure for the synthesis of arylsulfonyl triazolidinediones. *Tetrahedron Lett.* **2018**, *59* (4), 383–387. <https://doi.org/https://doi.org/10.1016/j.tetlet.2017.12.048>.
- (81) Yu, H.; Zhang, Y. NH₄I-Catalyzed Synthesis of Sulfonamides from Arylsulfonylhydrazides and Amines. *Chinese J. Chem.* **2016**, *34* (4), 359–362. <https://doi.org/10.1002/cjoc.201500796>.
- (82) Yotphan, S.; Sumunnee, L.; Beukeaw, D.; Buathongjan, C.; Reutrakul, V. Iodine-catalyzed expeditious synthesis of sulfonamides from sulfonyl hydrazides and amines. *Org. Biomol. Chem.* **2016**, *14* (2), 590–597. <https://doi.org/10.1039/C5OB02075A>.
- (83) Parumala, S. K. R.; Peddinti, R. K. Metal-free synthesis of sulfonamides via iodine-catalyzed oxidative coupling of sulfonyl hydrazides and amines. *Tetrahedron Lett.* **2016**, *57* (11), 1232–1235. <https://doi.org/https://doi.org/10.1016/j.tetlet.2016.02.009>.
- (84) Sheykhan, M.; Khani, S.; Abbasnia, M.; Shaabanzadeh, S.; Joafshan, M. An approach to C–N activation: coupling of arenesulfonyl hydrazides and arenesulfonyl chlorides with tert-amines via a metal-, oxidant- and halogen-free anodic oxidation. *Green Chem.* **2017**, *19* (24), 5940–5948. <https://doi.org/10.1039/C7GC03141F>.
- (85) Hofman, K.; Liu, N.-W.; Manolikakes, G. Radicals and Sulfur Dioxide: A Versatile Combination for the Construction of Sulfonyl-Containing Molecules. *Chem. – A Eur. J.* **2018**, *24* (46), 11852–11863. <https://doi.org/10.1002/chem.201705470>.
- (86) Du, B.; Wang, Y.; Sha, W.; Qian, P.; Mei, H.; Han, J.; Pan, Y. Copper-Catalyzed Selective Aerobic Oxidative Cascade Reaction of Hydrazines, DABSO, and Amines for the Direct Synthesis of Sulfonamides. *Asian J. Org. Chem.* **2017**, *6* (2), 153–156. <https://doi.org/10.1002/ajoc.201600518>.
- (87) Li, W.; Beller, M.; Wu, X.-F. Catalytic conversion of aryl triazenes into aryl sulfonamides using sulfur dioxide as the sulfonyl source. *Chem. Commun.* **2014**, *50* (67), 9513–9516. <https://doi.org/10.1039/C4CC03481C>.
- (88) Deeming, A. S.; Russell, C. J.; Willis, M. C. Combining Organometallic Reagents, the Sulfur Dioxide Surrogate DABSO, and Amines: A One-Pot Preparation of Sulfonamides, Amenable to Array Synthesis. *Angew. Chemie Int. Ed.* **2015**, *54* (4), 1168–1171. <https://doi.org/10.1002/anie.201409283>.
- (89) S. Tsai, A.; M. Curto, J.; N. Rocke, B.; R. Dechert-Schmitt, A.-M.; K. Ingle, G.; Mascitti, V. One-Step Synthesis of Sulfonamides from N-Tosylhydrazones. *Org. Lett.* **2016**, *18* (3), 508–511. <https://doi.org/10.1021/acs.orglett.5b03545>.

- (90) Brownbridge, P.; Jowett, I. C. "One-Pot" Synthesis of Sulphinic Esters from Disulphides. *Synthesis (Stuttg)*. **1988**, 1988 (03), 252–254. <https://doi.org/10.1055/s-1988-27535>.
- (91) Murineddu, G.; Deligia, F.; Ragusa, G.; García-Toscano, L.; Gómez-Cañas, M.; Asproni, B.; Satta, V.; Cichero, E.; Pazos, R.; Fossa, P.; Novel sulfenamides and sulfonamides based on pyridazinone and pyridazine scaffolds as CB1 receptor ligand antagonists. *Bioorg. Med. Chem.* **2018**, 26 (1), 295–307. <https://doi.org/https://doi.org/10.1016/j.bmc.2017.11.051>.
- (92) Li, G.; Sun, Q.; Wang, D.; Xu, Y.; Zhuang, J.; Zhang, Q.; Sun, D. Fluoroalkane thioheterocyclic derivatives and their antitumor activity. *Eur. J. Med. Chem.* **2015**, 93, 423–430. <https://doi.org/https://doi.org/10.1016/j.ejmech.2015.02.031>.
- (93) Miura, Y.; Tomimura, T.; Teki, Y. Heterocycle-Substituted Stable Thioaminy Radical: Isolation, ESR Spectra, and Magnetic Properties. *J. Org. Chem.* **2000**, 65 (23), 7889–7895. <https://doi.org/10.1021/jo000901q>.
- (94) Youseflouei, N.; Alizadeh, S.; Masoudi-Khoram, M.; Nematollahi, D.; Alizadeh, H. A comprehensive electrochemical study of 2-mercaptobenzoheterocyclic derivatives. Air-assisted electrochemical synthesis of new sulfonamide derivatives. *Electrochim. Acta* **2020**, 353, 136451. <https://doi.org/https://doi.org/10.1016/j.electacta.2020.136451>.
- (95) Lopez, M.; Bornaghi, L. F.; Poulsen, S.-A. Synthesis of sulfonamide-conjugated glycosyl-amino acid building blocks. *Carbohydr. Res.* **2014**, 386, 78–85. <https://doi.org/https://doi.org/10.1016/j.carres.2013.08.017>.
- (96) García Martínez, A.; Teso Vilar, E.; Moreno Jiménez, F.; María Álvarez García, A. A short and convenient procedure for the stereoselective synthesis of 2-hydroxy-1-norbornanesulfonamides. *Tetrahedron: Asymmetry* **2004**, 15 (2), 293–298. <https://doi.org/https://doi.org/10.1016/j.tetasy.2003.10.023>.
- (97) Gucchait, A.; Jana, K.; Misra, A. K. Convenient preparation of thioglycomimetics: S-glycosyl sulfenamides, sulfinamides and sulphonamides. *RSC Adv.* **2017**, 7 (52), 32478–32487. <https://doi.org/10.1039/C7RA05339H>.
- (98) Tasaka, A.; Teranishi, K.; Matsushita, Y.; Tamura, N.; Hayashi, R.; Okonogi, K.; Itoh, K. Optically Active Antifungal Azoles. III. Synthesis and Antifungal Activity of Sulfide and Sulfonamide Derivatives of (2R,3R)-2-(2,4-Difluorophenyl)-3-mercapto-1-(1H-1,2,4-triazol-1-yl)-2-butanol. *Chem. Pharm. Bull.* **1994**, 42 (1), 85–94. <https://doi.org/10.1248/cpb.42.85>.
- (99) Fletcher, S. The Mitsunobu reaction in the 21st century. *Org. Chem. Front.* **2015**, 2 (6), 739–752. <https://doi.org/10.1039/C5QO00016E>.
- (100) Fier, P. S.; Kim, S.; Maloney, K. M. Reductive Cleavage of Secondary Sulfonamides: Converting Terminal Functional Groups into Versatile Synthetic Handles. *J. Am. Chem. Soc.* **2019**, 141 (46), 18416–18420. <https://doi.org/10.1021/jacs.9b10985>.
- (101) Beisel, T.; Manolikakes, G. A Palladium-Catalyzed Three-Component Synthesis of Arylmethylsulfonamides. *Synthesis (Stuttg)*. **2016**, 48 (03), 379–386.

- (102) Diehl, A. M.; Ouadoudi, O.; Andreadou, E.; Manolikakes, G. Sulfonamides as Amine Component in the Petasis-Borono Mannich Reaction: A Concise Synthesis of α -Aryl- and α -Alkenylglycine Derivatives-. *Synthesis (Stuttg)*. **2018**, *50* (19), 3936–3946.
- (103) Deng, W.; Liu, L.; Zhang, C.; Liu, M.; Guo, Q.-X. Copper-catalyzed cross-coupling of sulfonamides with aryl iodides and bromides facilitated by amino acid ligands. *Tetrahedron Lett.* **2005**, *46* (43), 7295–7298. <https://doi.org/https://doi.org/10.1016/j.tetlet.2005.08.149>.
- (104) Baffoe, J.; Y. Hoe, M.; Barry Touré, B. Copper-Mediated N-Heteroarylation of Primary Sulfonamides: Synthesis of Mono-N-heteroaryl Sulfonamides. *Org. Lett.* **2010**, *12* (7), 1532–1535. <https://doi.org/10.1021/ol100263r>.
- (105) R. Rosen, B.; Craig Ruble, J.; J. Beauchamp, T.; Navarro, A. Mild Pd-Catalyzed N-Arylation of Methanesulfonamide and Related Nucleophiles: Avoiding Potentially Genotoxic Reagents and Byproducts. *Org. Lett.* **2011**, *13* (10), 2564–2567. <https://doi.org/10.1021/ol200660s>.
- (106) D. Hicks, J.; M. Hyde, A.; Martinez Cuezva, A.; L. Buchwald, S. Pd-Catalyzed N-Arylation of Secondary Acyclic Amides: Catalyst Development, Scope, and Computational Study. *J. Am. Chem. Soc.* **2009**, *131* (46), 16720–16734. <https://doi.org/10.1021/ja9044357>.
- (107) Kim, T.; McCarver, S. J.; Lee, C.; MacMillan, D. W. C. Sulfonamidation of Aryl and Heteroaryl Halides through Photosensitized Nickel Catalysis. *Angew. Chemie Int. Ed.* **2018**, *57* (13), 3488–3492. <https://doi.org/https://doi.org/10.1002/anie.201800699>.
- (108) Blackburn, J. M.; Gant Kanegusuku, A. L.; Scott, G. E.; Roizen, J. L. Photochemically-Mediated, Nickel-Catalyzed Synthesis of N-(Hetero)aryl Sulfamate Esters. *Org. Lett.* **2019**, *21* (17), 7049–7054. <https://doi.org/10.1021/acs.orglett.9b02621>.
- (109) McGuire, R. T.; Simon, C. M.; Yadav, A. A.; Ferguson, M. J.; Stradiotto, M. Nickel-Catalyzed Cross-Coupling of Sulfonamides With (Hetero)aryl Chlorides. *Angew. Chemie Int. Ed.* **2020**, *59* (23), 8952–8956. <https://doi.org/https://doi.org/10.1002/anie.202002392>.
- (110) Demain, A. L.; Fang, A. The Natural Functions of Secondary Metabolites. *Adv. Biochem. Eng. Biotechnol.* **2000**, *69*, 1–39. https://doi.org/10.1007/3-540-44964-7_1.
- (111) Pott, D. M.; Osorio, S.; Vallarino, J. G. From Central to Specialized Metabolism: An Overview of Some Secondary Compounds Derived From the Primary Metabolism for Their Role in Conferring Nutritional and Organoleptic Characteristics to Fruit . *Frontiers in Plant Science* **2019**, 835.
- (112) Agar, O. T.; Cankaya, I. I. T. Analysis of phenylethanoids and their glycosidic derivatives. *Recent Advances in Natural Products Analysis*; Sanches Silva, A., Nabavi, S. F., Saeedi, M., Nabavi, S. M. B. T.-R. A. in N. P. A.; Elsevier, 2020; 221–254. <https://doi.org/10.1016/B978-0-12-816455-6.00005-6>.
- (113) Vogt, T. Phenylpropanoid Biosynthesis. *Mol. Plant* **2010**, *3* (1), 2–20. <https://doi.org/https://doi.org/10.1093/mp/ssp106>.
- (114) Fitria. *J. Chem. Inf. Model.* **2013**, *53* (9), 1689–1699.

- (115) Zálešák, F.; Bon, D. J.-Y. D.; Pospíšil, J. Lignans and Neolignans: Plant secondary metabolites as a reservoir of biologically active substances. *Pharmacol. Res.* **2019**, *146*. <https://doi.org/10.1016/j.phrs.2019.104284>.
- (116) Orlandi, M.; Rindone, B.; Molteni, G.; Rummakko, P.; Brunow, G. Asymmetric biomimetic oxidations of phenols: the mechanism of the diastereo- and enantioselective synthesis of dehydrodiconiferyl ferulate (DDF) and dehydrodiconiferyl alcohol (DDA). *Tetrahedron* **2001**, *57* (2), 371–378. [https://doi.org/https://doi.org/10.1016/S0040-4020\(00\)00944-3](https://doi.org/https://doi.org/10.1016/S0040-4020(00)00944-3).
- (117) Higuchi, T. Biosynthesis of Lignin BT - Plant Carbohydrates II: Extracellular Carbohydrates; Tanner, W., Loewus, F. A., Springer Berlin Heidelberg: Berlin, Heidelberg, 1981; 194–224. https://doi.org/10.1007/978-3-642-68234-6_9.
- (118) Nascimento, I. R.; Lopes, L. M. X.; Davin, L. B.; Lewis, N. G. Stereoselective Synthesis of 8,9-Licarinediols. *Tetrahedron* **2000**, *56* (47), 9181–9193. [https://doi.org/https://doi.org/10.1016/S0040-4020\(00\)00873-5](https://doi.org/https://doi.org/10.1016/S0040-4020(00)00873-5).
- (119) Shiba, T.; Xiao, L.; Miyakoshi, T.; Chen, C.-L. Oxidation of isoeugenol and coniferyl alcohol catalyzed by laccases isolated from *Rhus vernicifera* Stokes and *Pycnoporus coccineus*. *J. Mol. Catal. B Enzym.* **2000**, *10* (6), 605–615. [https://doi.org/https://doi.org/10.1016/S1381-1177\(00\)00184-3](https://doi.org/https://doi.org/10.1016/S1381-1177(00)00184-3).
- (120) Kuo, Y. H.; Lin, S. T. Ferric chloride oxidation of isoeugenol. *Experientia* **1983**, *39* (9), 991–993. <https://doi.org/10.1007/BF01989766>.
- (121) F, K. Ge. *Angew. Chemie Int. Ed.* **6**(11), 951–952. **1967**, *47*, 610–616.
- (122) Kuo, Y.-H.; Chen, L.-H.; Wang, L.-M. Photosensitized Oxidation of Isoeugenol in Protic and Aprotic Solvents. *Chem. Pharm. Bull. (Tokyo)*. **1991**, *39* (9), 2196–2200. <https://doi.org/10.1248/cpb.39.2196>.
- (123) Tan, J.-P.; Yu, P.; Wu, J.-H.; Chen, Y.; Pan, J.; Jiang, C.; Ren, X.; Zhang, H.-S.; Wang, T. Bifunctional Phosphonium Salt Directed Enantioselective Formal [4 + 1] Annulation of Hydroxyl-Substituted para-Quinone Methides with α -Halogenated Ketones. *Org. Lett.* **2019**, *21* (18), 7298–7302. <https://doi.org/10.1021/acs.orglett.9b02560>.
- (124) Chen, M.-W.; Cao, L.-L.; Ye, Z.-S.; Jiang, G.-F.; Zhou, Y.-G. A mild method for generation of o-quinone methides under basic conditions. The facile synthesis of trans-2,3-dihydrobenzofurans. *Chem. Commun.* **2013**, *49* (16), 1660–1662. <https://doi.org/10.1039/C3CC37800D>.
- (125) Osyanin, V. A.; Osipov, D. V; Klimochkin, Y. N. Reactions of o-Quinone Methides with Pyridinium Methylenes: A Diastereoselective Synthesis of 1,2-Dihydronaphtho[2,1-b]furans and 2,3-Dihydrobenzofurans. *J. Org. Chem.* **2013**, *78* (11), 5505–5520. <https://doi.org/10.1021/jo400621r>.
- (126) Fischer, J.; Paul Savage, G.; J. Coster, M. A Concise Route to Dihydrobenzo[b]furans: Formal Total Synthesis of (+)-Lithospermic Acid. *Org. Lett.* **2011**, *13* (13), 3376–3379. <https://doi.org/10.1021/ol201130h>.

- (127) Qin, L.; Vo, D.-D.; Nakhai, A.; Andersson, C. D.; Eloffsson, M. Diversity-Oriented Synthesis of Libraries Based on Benzofuran and 2,3-Dihydrobenzofuran Scaffolds. *ACS Comb. Sci.* **2017**, *19* (6), 370–376. <https://doi.org/10.1021/acscombsci.7b00014>.
- (128) Alonso-Marañón, L.; Montserrat Martínez, M.; A. Sarandeses, L.; Gómez-Bengo, E.; Pérez Sestelo, J. Indium(III)-Catalyzed Synthesis of Benzo[b]furans by Intramolecular Hydroalkoxylation of ortho-Alkynylphenols: Scope and Mechanistic Insights. *J. Org. Chem.* **2018**, *83* (15), 7970–7980. <https://doi.org/10.1021/acs.joc.8b00829>.
- (129) Singh, F. V.; Mangaonkar, S. R. Hypervalent Iodine(III)-Catalyzed Synthesis of 2-Arylbzofurans. *Synthesis (Stuttg)*. **2018**, *50* (24), 4940–4948.
- (130) Rajesh, M.; Thirupathi, N.; Jagadeshwar Reddy, T.; Kanojiya, S.; Sridhar Reddy, M. Pd-Catalyzed Isocyanide Assisted Reductive Cyclization of 1-(2-Hydroxyphenyl)-propargyl Alcohols for 2-Alkyl/Benzyl Benzofurans and Their Useful Oxidative Derivatization. *J. Org. Chem.* **2015**, *80* (24), 12311–12320. <https://doi.org/10.1021/acs.joc.5b02204>.
- (131) Zhou, L.; Shi, Y.; Xiao, Q.; Liu, Y.; Ye, F.; Zhang, Y.; Wang, J. CuBr-Catalyzed Coupling of N-Tosylhydrazones and Terminal Alkynes: Synthesis of Benzofurans and Indoles. *Org. Lett.* **2011**, *13* (5), 968–971. <https://doi.org/10.1021/ol103009n>.
- (132) Chen, C.; G. Dormer, P. Synthesis of Benzo[b]furans via CuI-Catalyzed Ring Closure. *J. Org. Chem.* **2005**, *70* (17), 6964–6967. <https://doi.org/10.1021/jo050788+>.
- (133) Carril, M.; SanMartin, R.; Tellitu, I.; Domínguez, E. On-Water Chemistry: Copper-Catalyzed Straightforward Synthesis of Benzo[b]furan Derivatives in Neat Water. *Org. Lett.* **2006**, *8* (7), 1467–1470. <https://doi.org/10.1021/ol060274c>.
- (134) Kuram, M. R.; Bhanuchandra, M.; Sahoo, A. K. Direct Access to Benzo[b]furans through Palladium-Catalyzed Oxidative Annulation of Phenols and Unactivated Internal Alkynes. *Angew. Chemie Int. Ed.* **2013**, *52* (17), 4607–4612. <https://doi.org/https://doi.org/10.1002/anie.201210217>.
- (135) Sharma, U.; Naveen, T.; Maji, A.; Manna, S.; Maiti, D. Palladium-Catalyzed Synthesis of Benzofurans and Coumarins from Phenols and Olefins. *Angew. Chemie Int. Ed.* **2013**, *52* (48), 12669–12673. <https://doi.org/https://doi.org/10.1002/anie.201305326>.
- (136) Agasti, S.; Sharma, U.; Naveen, T.; Maiti, D. Orthogonal selectivity with cinnamic acids in 3-substituted benzofuran synthesis through C–H olefination of phenols. *Chem. Commun.* **2015**, *51* (25), 5375–5378. <https://doi.org/10.1039/C4CC07026G>.
- (137) Dudley, M. E.; Morshed, M. M.; Hossain, M. M. A Convenient Method of Synthesizing 3-Ethoxycarbonylbzofurans from Salicylaldehydes and Ethyl Diazoacetate. *Synthesis (Stuttg)*. **2006**, *2006* (10), 1711–1714.
- (138) Sun, P.; Gao, S.; Yang, C.; Guo, S.; Lin, A.; Yao, H. Controllable Rh(III)-Catalyzed Annulation between Salicylaldehydes and Diazo Compounds: Divergent Synthesis of Chromones and Benzofurans. *Org. Lett.* **2016**, *18* (24), 6464–6467. <https://doi.org/10.1021/acs.orglett.6b03355>.
- (139) K. Nielsen, M.; R. Ugaz, C.; Li, W.; G. Doyle, A. PyFluor: A Low-Cost, Stable, and Selective Deoxyfluorination Reagent. *J. Am. Chem. Soc.* **2015**, *137* (30), 9571–9574. <https://doi.org/10.1021/jacs.5b06307>.

- (140) Vedejs, E.; Kongkittigam, C. Solution-Phase Synthesis of a Hindered N-Methylated Tetrapeptide Using Bts-Protected Amino Acid Chlorides: Efficient Coupling and Methylation Steps Allow Purification by Extraction. *J. Org. Chem.* **2000**, *65* (8), 2309–2318. <https://doi.org/10.1021/jo9914115>.
- (141) Diltz, S.; Aguirre, G.; Ortega, F.; Walsh, P. J. Synthesis of chiral heteroaromatic tetradentate sulfonamide based ligands. *Tetrahedron: Asymmetry* **1997**, *8* (21), 3559–3562. [https://doi.org/https://doi.org/10.1016/S0957-4166\(97\)00517-X](https://doi.org/https://doi.org/10.1016/S0957-4166(97)00517-X).
- (142) J. Day, J.; Yang, Z.; Chen, W.; Pacheco, A.; Xian, M. Benzothiazole Sulfinate: a Water-Soluble and Slow-Releasing Sulfur Dioxide Donor. *ACS Chem. Biol.* **2016**, *11* (6), 1647–1651. <https://doi.org/10.1021/acscchembio.6b00106>.
- (143) J. Day, J.; L. Neill, D.; Xu, S.; Xian, M. Benzothiazole Sulfinate: A Sulfinic Acid Transfer Reagent under Oxidation-Free Conditions. *Org. Lett.* **2017**, *19* (14), 3819–3822. <https://doi.org/10.1021/acs.orglett.7b01693>.
- (144) Brownbridge, P.; Jowett, I. C. On the reaction of benzothiazol-2-yl sulphenamides with phosphites. *Phosphorus Sulfur Relat. Elem.* **1988**, *35* (3–4), 311–318. <https://doi.org/10.1080/03086648808074335>.
- (145) Komoriya, S.; Haginoya, N.; Kobayashi, S.; Nagata, T.; Mochizuki, A.; Suzuki, M.; Yoshino, T.; Horino, H.; Nagahara, T.; Suzuki, M.; آخ. Design, synthesis, and biological activity of non-basic compounds as factor Xa inhibitors: SAR study of S1 and aryl binding sites. *Bioorg. Med. Chem.* **2005**, *13* (12), 3927–3954. <https://doi.org/https://doi.org/10.1016/j.bmc.2005.04.006>.
- (146) Chan, C.; D. Borthwick, A.; Brown, D.; L. Burns-Kurtis, C.; Campbell, M.; Chaudry, L.; Chung, C.; A. Convery, M.; Nicole Hamblin, J.; Johnstone, L.; Factor Xa Inhibitors: S1 Binding Interactions of a Series of N-{(3S)-1-[(1S)-1-Methyl-2-morpholin-4-yl-2-oxoethyl]-2-oxopyrrolidin-3-yl}sulfonamides. *J. Med. Chem.* **2007**, *50* (7), 1546–1557. <https://doi.org/10.1021/jm060870c>.
- (147) Bon, D. J. Y. D.; Kováč, O.; Ferugová, V.; Zálešák, F.; Pospíšil, J. One and Two-Carbon Homologation of Primary and Secondary Alcohols to Corresponding Carboxylic Esters Using β -Carbonyl BT Sulfones as a Common Intermediate. *J. Org. Chem.* **2018**, *83* (9), 4990–5001. <https://doi.org/10.1021/acs.joc.8b00112>.
- (148) Robiette, R.; Pospíšil, J. On the Origin of E/Z Selectivity in the Modified Julia Olefination – Importance of the Elimination Step. *European J. Org. Chem.* **2013**, *2013* (5), 836–840. <https://doi.org/10.1002/ejoc.201201634>.
- (149) Miguel, E. L. M.; Silva, P. L.; Pliego, J. R. Theoretical Prediction of pKa in Methanol: Testing SM8 and SMD Models for Carboxylic Acids, Phenols, and Amines. *J. Phys. Chem. B* **2014**, *118* (21), 5730–5739. <https://doi.org/10.1021/jp501379p>.
- (150) Díaz-Ortiz, Á.; Prieto, P.; de la Hoz, A. A Critical Overview on the Effect of Microwave Irradiation in Organic Synthesis. *Chem. Rec.* **2019**, *19* (1), 85–97. <https://doi.org/10.1002/tcr.201800059>.

- (151) Jacob, A. M.; Moody, C. J. Microwave-assisted combined Mitsunobu reaction–Claisen rearrangement and microwave-assisted phenol oxidation: rapid synthesis of 2,6-disubstituted-1,4-benzoquinone natural products. *Tetrahedron Lett.* **2005**, *46* (51), 8823–8825. <https://doi.org/https://doi.org/10.1016/j.tetlet.2005.10.096>.
- (152) Steinreiber, A.; Stadler, A.; Mayer, S. F.; Faber, K.; Kappe, C. O. High-speed microwave-promoted Mitsunobu inversions. Application toward the deracemization of sulcatol. *Tetrahedron Lett.* **2001**, *42* (36), 6283–6286. [https://doi.org/https://doi.org/10.1016/S0040-4039\(01\)01248-5](https://doi.org/https://doi.org/10.1016/S0040-4039(01)01248-5).
- (153) Manvar, A.; Shah, A. Subtle Mitsunobu couplings under super-heating: the role of high-throughput continuous flow and microwave strategies. *Org. Biomol. Chem.* **2014**, *12* (41), 8112–8124. <https://doi.org/10.1039/C4OB01432D>.
- (154) Dorel, R.; Grugel, C. P.; Haydl, A. M. The Buchwald–Hartwig Amination After 25 Years. *Angew. Chemie - Int. Ed.* **2019**, *58* (48), 17118–17129. <https://doi.org/10.1002/anie.201904795>.
- (155) Forero-Cortés, P. A.; Haydl, A. M. The 25th Anniversary of the Buchwald–Hartwig Amination: Development, Applications, and Outlook. *Org. Process Res. Dev.* **2019**, *23* (8), 1478–1483. <https://doi.org/10.1021/acs.oprd.9b00161>.
- (156) Zu, W.; Liu, S.; Jia, X.; Xu, L. Chemoselective N-arylation of aminobenzene sulfonamides via copper catalysed Chan–Evans–Lam reactions. *Org. Chem. Front.* **2019**, *6* (9), 1356–1360. <https://doi.org/10.1039/C8QO01313F>.
- (157) C. Vantourout, J.; N. Miras, H.; Isidro-Llobet, A.; Sproules, S.; J. B. Watson, A. Spectroscopic Studies of the Chan–Lam Amination: A Mechanism-Inspired Solution to Boronic Ester Reactivity. *J. Am. Chem. Soc.* **2017**, *139* (13), 4769–4779. <https://doi.org/10.1021/jacs.6b12800>.
- (158) Yu, T.-Y.; Zheng, Z.-J.; Bai, J.-H.; Fang, H.; Wei, H. Nickel-Catalyzed Intramolecular Coupling of Sulfones via the Extrusion of Sulfur Dioxide. *Adv. Synth. Catal.* **2019**, *361* (9), 2020–2024. <https://doi.org/https://doi.org/10.1002/adsc.201801733>.
- (159) Zu, W.; Liu, S.; Jia, X.; Xu, L. Chemoselective: N -arylation of aminobenzene sulfonamides via copper catalysed Chan-Evans-Lam reactions. *Org. Chem. Front.* **2019**, *6* (9), 1356–1360. <https://doi.org/10.1039/c8qo01313f>.
- (160) Vantourout, J. C.; Li, L.; Bendito-Moll, E.; Chabbra, S.; Arrington, K.; Bode, B. E.; Isidro-Llobet, A.; Kowalski, J. A.; Nilson, M. G.; Wheelhouse, K. M. P.; Mechanistic Insight Enables Practical, Scalable, Room Temperature Chan-Lam N-Arylation of N-Aryl Sulfonamides. *ACS Catal.* **2018**, *8* (10), 9560–9566. <https://doi.org/10.1021/acscatal.8b03238>.
- (161) Chen, J.; Li, J.; Dong, Z. A Review on the Latest Progress of Chan-Lam Coupling Reaction. *Adv. Synth. Catal.* **2020**, *362* (16), 3311–3331. <https://doi.org/10.1002/adsc.202000495>.

- (162) Vantourout, J. C.; Li, L.; Bendito-Moll, E.; Chabbra, S.; Arrington, K.; E. Bode, B.; Isidro-Llobet, A.; A. Kowalski, J.; G. Nilson, M.; M. P. Wheelhouse, K.; Mechanistic Insight Enables Practical, Scalable, Room Temperature Chan–Lam N-Arylation of N-Aryl Sulfonamides. *ACS Catal.* **2018**, *8* (10), 9560–9566. <https://doi.org/10.1021/acscatal.8b03238>.
- (163) Yuan, C.; Zheng, L.; Zhao, Y. Cu(II)-Catalyzed Homocouplings of (Hetero)Arylboronic Acids with the Assistance of 2-O-Methyl-d-Glucopyranose. *Molecules* **2019**, *24* (20), 3678. <https://doi.org/10.3390/molecules24203678>.
- (164) Henderson, A. R. P.; Kosowan, J. R.; Wood, T. E. The Truce–Smiles rearrangement and related reactions: a review. *Can. J. Chem.* **2017**, *95* (5), 483–504. <https://doi.org/10.1139/cjc-2016-0594>.
- (165) Blakemore, P. R. The modified Julia olefination: alkene synthesis via the condensation of metallated heteroarylalkylsulfones with carbonyl compounds. *J. Chem. Soc. Perkin Trans. 1* **2002**, *23*, 2563–2585. <https://doi.org/10.1039/B208078H>.
- (166) Blakemore, P. R.; Cole, W. J.; Kociński, P. J.; Morley, A. A Stereoselective Synthesis of Trans-1,2-Disubstituted Alkenes Based on the Condensation of Aldehydes with Metallated 1-Phenyl-1H-Tetrazol-5-Yl Sulfones. *Synlett* **1998**, *1998* (01), 26–28.
- (167) Pospíšil, J. Simple protocol for enhanced (E)-selectivity in Julia–Kocienski reaction. *Tetrahedron Lett.* **2011**, *52* (18), 2348–2352. <https://doi.org/https://doi.org/10.1016/j.tetlet.2011.02.086>.
- (168) Holden, C. M.; Soheli, S. M. A.; Greaney, M. F. Metal Free Bi(hetero)aryl Synthesis: A Benzyne Truce–Smiles Rearrangement. *Angew. Chemie Int. Ed.* **2016**, *55* (7), 2450–2453. <https://doi.org/https://doi.org/10.1002/anie.201510236>.
- (169) Rabet, P. T. G.; Boyd, S.; Greaney, M. F. Metal-Free Intermolecular Aminoarylation of Alkynes. *Angew. Chemie Int. Ed.* **2017**, *56* (15), 4183–4186. <https://doi.org/https://doi.org/10.1002/anie.201612445>.
- (170) Barlow, H. L.; T. G. Rabet, P.; Durie, A.; Evans, T.; F. Greaney, M. Arylation Using Sulfonamides: Phenylacetamide Synthesis through Tandem Acylation–Smiles Rearrangement. *Org. Lett.* **2019**, *21* (22), 9033–9035. <https://doi.org/10.1021/acs.orglett.9b03429>.
- (171) Johnson, S.; Kovács, E.; Greaney, M. F. Arylation and alkenylation of activated alkyl halides using sulfonamides. *Chem. Commun.* **2020**, *56* (21), 3222–3224. <https://doi.org/10.1039/D0CC00220H>.
- (172) Knowles, R. R.; Jacobsen, E. N. Attractive noncovalent interactions in asymmetric catalysis: Links between enzymes and small molecule catalysts. *Proc. Natl. Acad. Sci.* **2010**, *107* (48), 20678 LP – 20685. <https://doi.org/10.1073/pnas.1006402107>.
- (173) Hine, J.; Meei Linden, S.; M. Kanagasabapathy, V. 1,8-biphenylenediol is a double-hydrogen-bonding catalyst for reaction of an epoxide with a nucleophile. *J. Am. Chem. Soc.* **2002**, *107* (4), 1082–1083. <https://doi.org/10.1021/ja00290a067>.

- (174) P. Curran, D.; Huang Kuo, L. Altering the Stereochemistry of Allylation Reactions of Cyclic α -Sulfinyl Radicals with Diarylureas. *J. Org. Chem.* **2002**, *59* (12), 3259–3261. <https://doi.org/10.1021/jo00091a007>.
- (175) G. Doyle, A.; N. Jacobsen, E. Small-Molecule H-Bond Donors in Asymmetric Catalysis. *Chem. Rev.* **2007**, *107* (12), 5713–5743. <https://doi.org/10.1021/cr068373r>.
- (176) Mase, N.; Tanaka, F.; Barbas III, C. F. Synthesis of β -Hydroxyaldehydes with Stereogenic Quaternary Carbon Centers by Direct Organocatalytic Asymmetric Aldol Reactions. *Angew. Chemie Int. Ed.* **2004**, *43* (18), 2420–2423. <https://doi.org/https://doi.org/10.1002/anie.200353546>.
- (177) Sohtome, Y.; Hashimoto, Y.; Nagasawa, K. Diastereoselective and Enantioselective Henry (Nitroaldol) Reaction Utilizing a Guanidine–Thiourea Bifunctional Organocatalyst. *European J. Org. Chem.* **2006**, *2006* (13), 2894–2897. <https://doi.org/https://doi.org/10.1002/ejoc.200600307>.
- (178) Li, H.; Wang, Y.-Q.; Deng, L. Enantioselective Friedel–Crafts Reaction of Indoles with Carbonyl Compounds Catalyzed by Bifunctional Cinchona Alkaloids. *Org. Lett.* **2006**, *8* (18), 4063–4065. <https://doi.org/10.1021/ol061552a>.
- (179) Borovika, A.; Tang, P.-I.; Klapman, S.; Nagorny, P. Thiophosphoramidate-Based Cooperative Catalysts for Brønsted Acid Promoted Ionic Diels–Alder Reactions. *Angew. Chemie Int. Ed.* **2013**, *52* (50), 13424–13428. <https://doi.org/https://doi.org/10.1002/anie.201307133>.
- (180) Zhu, Z.; Odagi, M.; Supantanapong, N.; Xu, W.; Saame, J.; Kirm, H.-U.; A. Abboud, K.; Leito, I.; Seidel, D. Modular Design of Chiral Conjugate-Base-Stabilized Carboxylic Acids: Catalytic Enantioselective [4 + 2] Cycloadditions of Acetals. *J. Am. Chem. Soc.* **2020**, *142* (36), 15252–15258. <https://doi.org/10.1021/jacs.0c07212>.
- (181) Tonoi, T.; Mikami, K. Chiral bis-trifluoromethanesulfonylamide as a chiral Brønsted acid catalyst for the asymmetric hetero Diels–Alder reaction with Danishefsky's diene. *Tetrahedron Lett.* **2005**, *46* (37), 6355–6358. <https://doi.org/https://doi.org/10.1016/j.tetlet.2005.07.043>.
- (182) Madarász, Á.; Dósa, Z.; Varga, S.; Soós, T.; Csámpai, A.; Pápai, I. Thiourea Derivatives as Brønsted Acid Organocatalysts. *ACS Catal.* **2016**, *6* (7), 4379–4387. <https://doi.org/10.1021/acscatal.6b00618>.
- (183) Zhao, G.-L.; Xu, Y.; Sundén, H.; Eriksson, L.; Sayah, M.; Córdova, A. Organocatalytic enantioselective conjugate addition of aldehydes to maleimides. *Chem. Commun.* **2007**, *7*, 734–735. <https://doi.org/10.1039/B614962F>.
- (184) Zálešák, F.; Bon, D. J.-Y. D. D. J.-Y. D.; Pospíšil, J. Lignans and Neolignans: Plant secondary metabolites as a reservoir of biologically active substances. *Pharmacol. Res.* **2019**, *146*, 104284.
- (185) Seca, A. M. L.; Silva, A. M. S.; Silvestre, A. J. D.; Cavaleiro, J. A. S.; Domingues, F. M. J.; Pascoal-Neto, C. Phenolic constituents from the core of Kenaf (*Hibiscus cannabinus*). *Phytochemistry* **2001**, *56* (7), 759–767. [https://doi.org/https://doi.org/10.1016/S0031-9422\(00\)00473-8](https://doi.org/https://doi.org/10.1016/S0031-9422(00)00473-8).

- (186) F. Paula, V.; C.A. Barbosa, L.; W. Howarth, O.; J. Demuner, A.; B. Cass, Q.; J.C. Vieira, I. Lignans from *Ochroma lagopus* Swartz. *Tetrahedron* **1995**, *51* (45), 12453–12462. [https://doi.org/https://doi.org/10.1016/0040-4020\(95\)00801-E](https://doi.org/https://doi.org/10.1016/0040-4020(95)00801-E).
- (187) Rudyansyah; Lambert, L. K.; Garson, M. J. Lignans and triterpenes from the bark of *Durio carinatus* and *Durio oxleyanus*. *J. Nat. Prod.* **2010**, *73* (10), 1649–1654. <https://doi.org/10.1021/np100332v>.
- (188) Shono, T.; Ishikawa, N.; Toume, K.; Arai, M. A.; Ahmed, F.; Sadhu, S. K.; Ishibashi, M. Boehmenan, a lignan from *Hibiscus ficulneus*, showed Wnt signal inhibitory activity. *Bioorg. Med. Chem. Lett.* **2015**, *25* (14), 2735–2738. <https://doi.org/https://doi.org/10.1016/j.bmcl.2015.05.037>.
- (189) Fuentes, R. G.; Arai, M. A.; Ishibashi, M. Natural compounds with Wnt signal modulating activity. *Nat. Prod. Rep.* **2015**, *32* (12), 1622–1628. <https://doi.org/10.1039/C5NP00074B>.
- (190) Pan, L.-L.; Wang, X.-L.; Zhang, Q.-Y.; Luo, X.-L.; Xu, P.; Liu, S.-Y.; Hu, J.-F.; Liu, X.-H. Boehmenan, a lignan from the Chinese medicinal plant *Clematis armandii*, induces apoptosis in lung cancer cells through modulation of EGF-dependent pathways. *Phytomedicine* **2016**, *23* (5), 468–476. <https://doi.org/https://doi.org/10.1016/j.phymed.2016.02.006>.
- (191) Guo, X.; Yu, R.; Li, H.; Li, Z. Iron-Catalyzed Tandem Oxidative Coupling and Annulation: An Efficient Approach to Construct Polysubstituted Benzofurans. *J. Am. Chem. Soc.* **2009**, *131* (47), 17387–17393. <https://doi.org/10.1021/ja907568j>.
- (192) Parnes, R.; A. Kshirsagar, U.; Werbeloff, A.; Regev, C.; Pappo, D. Ligand-Controlled Iron-Catalyzed Coupling of α -Substituted β -Ketoesters with Phenols. *Org. Lett.* **2012**, *14* (13), 3324–3327. <https://doi.org/10.1021/ol301297k>.
- (193) Barbušáková, Z.; Kozubíková, H.; Zálešák, F.; Doležal, K.; Pospíšil, J. General approach to neolignan-core of the boehmenan natural product family. *Monatshefte für Chemie* **2018**, *149* (4), 737–748. <https://doi.org/10.1007/s00706-017-2132-4>.
- (194) Zhang, X.; Liu, S.; Lao, J.; Du, G.; Yan, M.; Chan, A. S. C. Asymmetric conjugate addition of carbonyl compounds to nitroalkenes catalyzed by chiral bifunctional thioureas. *Tetrahedron: Asymmetry* **2009**, *20* (12), 1451–1458. <https://doi.org/https://doi.org/10.1016/j.tetasy.2009.06.003>.
- (195) Schnell, S. D.; Schilling, M.; Sklyaruk, J.; Linden, A.; Lubber, S.; Gademann, K. Nucleophilic Attack on Nitrogen in Tetrazines by Silyl-Enol Ethers. *Org. Lett.* **2021**, *23* (7), 2426–2430. <https://doi.org/10.1021/acs.orglett.0c04113>.
- (196) Zhang, E.; Tian, H.; Xu, S.; Yu, X.; Xu, Q. Iron-Catalyzed Direct Synthesis of Imines from Amines or Alcohols and Amines via Aerobic Oxidative Reactions under Air. *Org. Lett.* **2013**, *15* (11), 2704–2707. <https://doi.org/10.1021/ol4010118>.
- (197) Cui, Y.; Jiang, H.; Li, Z.; Wu, N.; Yang, Z.; Quan, J. Unexpected Regioselectivity in the Synthesis of Pyranonaphthoquinone via the Diels–Alder Reaction. *Org. Lett.* **2009**, *11* (20), 4628–4631. <https://doi.org/10.1021/ol901902v>.

- (198) Iwasaki, M.; Fujii, T.; Yamamoto, A.; Nakajima, K.; Nishihara, Y. Palladium-Catalyzed Regio- and Stereoselective Chlorothiolation of Terminal Alkynes with Sulfenyl Chlorides. *Chem. – An Asian J.* **2014**, *9* (1), 58–62. <https://doi.org/10.1002/asia.201301295>.
- (199) L. Chang, L.; B. Denney, D.; Z. Denney, D.; J. Kazior, R. Some Acyclic Pentaalkoxyphosphoranes. *J. Am. Chem. Soc.* **2002**, *99* (7), 2293–2297. <https://doi.org/10.1021/ja00449a044>

7 Experimental part

All reactions were performed in round-bottom flasks fitted with rubber septa using the standard laboratory techniques. Reactions sensitive to air and/or moisture were performed under a positive pressure of argon. Reactions run at elevated temperatures were carried out using the oil bath and indicated temperatures refers to the oil bath temperature. All starting materials were purchased from commercial suppliers and used without further purification, unless otherwise stated. Progress of reactions was monitored by thin-layer chromatography (TLC) - aluminum plates pre-coated with silica gel (silica gel 60 F254). Column chromatography was performed on silica gel 60 (40-63 μm). Determination of melting points were done on a Büchi melting point apparatus and were uncorrected. ^1H NMR, ^{19}F $\{^1\text{H}\}$ NMR and ^{13}C $\{^1\text{H}\}$ NMR spectra were measured on Jeol ECA400II (400 MHz, 376 MHz and 100 MHz, respectively) or Jeol 500 ECA (500 and 126 MHz) in CDCl_3 or DMSO. Chemical shifts are reported in ppm and their calibration was performed (a) in case of ^1H NMR experiments on residual peak of non-deuterated solvent δ (CHCl_3) = 7.26 ppm; δ (DMSO) = 2.50 ppm, and (b) in case of ^{13}C NMR experiments on the middle peak of the ^{13}C signal in deuterated solvent δ (CDCl_3) = 77.2 ppm; δ ($\text{DMSO-}d_6$) = 39.5 ppm. Proton coupling patterns are represented as singlet (s), doublet (d), doublet of doublet (dd), triplet (t), triplet of triplet (tt) and multiplet (m). HRMS analyses were performed on Thermo Exactive Plus high-resolution mass spectrometer with electrospray ionization (ESI) and Orbitrap analyzer operating at positive or negative full scan mode in the range of 60-800 m/z or on Agilent 6230 high resolution mass spectrometer with electrospray ionization (ESI) and time-of-flight analyzer operating at positive or negative full scan mode in the range of 100-1700 m/z. SFC chiral analyses were performed using an Acquity UPC2 system (Waters) consisting of a binary solvent manager, sample manager, column manager, column heater, convergence manager, PDA detector 2998, QDa mass detector and chiral analytical columns Chiralpak IA3 (4.6 mm \times 100 mm, 3 μm particle size) and Chiralpak IE3 (4.6 mm \times 100 mm, 3 μm particle size). The chromatographic runs were performed at a flow rate of 2.2 mL/min, column temperature of 38 $^\circ\text{C}$, and ABPR 2000 psi. Microwave irradiation experiments were carried out in a dedicated CEM-Discover mono-mode microwave apparatus. The reactor was used in the standard configuration as delivered, including proprietary software. The reactions were carried out in 10 mL glass vials sealed with a Silicone/PTFE Vial caps top, which can be exposed to a maximum of 250 $^\circ\text{C}$ and 20 bar internal pressure. The temperature was measured with an IR sensor on the outer surface of the process vial. After the irradiation period, the reaction vessel was cooled to ambient temperature by gas jet cooling. Purification

using semiprep HPLC was carried out on Agilent 1200 series using the C18 reverse-phase column (YMC Pack ODS-A, 20x100 mm, 5 mm particles). Gradient was formed from 10 mM aqueous ammonium acetate (buffer) and CH₃CN of flow rate of 15 mL/min. Potentiometric titration for the determination of dissociation constant was carried out using benchtop meter pH 50+ DHS (Instruments XS, Italy) equipped with ATC glass electrode. Before each measurement, pH meter was calibrated with pH 4.01 and 7.00 buffer solutions. The titration was performed using Titronic® basic piston burette (Schott Instruments, Germany). A 0.01 M basic solution was prepared by a dissolving of appropriate amount of 50% (w/v) aqueous sodium hydroxide solution purchased from Sigma-Aldrich in deionized water (Merck Millipore, USA). The titrant was added in 0.02 mL increments. Dissociation constants were calculated from obtained titration curve.

Sodium benzo[d]thiazole-2-sulfinate (4-1) synthesis

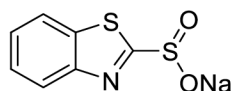

Disulfide (2.0 g, 6.0 mmol, 1 equiv) was dissolved in dry CH₂Cl₂ (25 mL) and MeOH (25 mL). NBS (5.36 g, 30 mmol, 5 equiv) was added portionwise within 5 min and the reaction progress was followed by TLC. After disulfide consumption, the reaction was quenched with sat. aq. NaHCO₃ (25 mL) and the whole mixture was extracted with CH₂Cl₂ (3 x 30 mL). Combined organic layers were washed with brine (25 mL), dried over MgSO₄, and the solvents were evaporated under reduced pressure. The residue was purified by flash column chromatography (SiO₂, EtOAc/petroleum ether = 1:3) and the concentration of relevant fractions yielded the desired product as yellowish amorphous solid (0.83 g, 65%). ¹H NMR (400 MHz, Chloroform-*d*): δ 7.54 (ddd, J = 8.0, 7.2, 1.3 Hz, 1H), 7.60 (ddd, J = 8.3, 7.2, 1.4 Hz, 1H), 8.01 (ddd, J = 7.9, 1.4, 0.7 Hz, 1H), 8.18 (ddd, J = 8.2, 1.4, 0.7 Hz, 1H), 3.74 (s, 3H); ¹³C {¹H} NMR (101 MHz, Chloroform-*d*): δ 175.0, 153.8, 136.2, 127.3, 127.3, 125.1, 122.5, 51.5; MS (ESI) *m/z* (%) 214: [M+H]⁺ (78); HRMS (ESI) *m/z*: [M+H]⁺ calcd. for C₈H₈NO₂S₂, 213.9991; found 213.9994.

Methyl sulfinate (1.3 g, 6 mmol, 1 equiv) was dissolved in THF (3 mL), and H₂O (3 mL) was added. Sodium hydroxide (0.243 g, 6 mmol, 1 equiv; powder) was added to the suspension at RT. The whole mixture became clear within 1 min and the conversion of starting methyl ester was monitored by TLC. After the reaction completion, the organic solvents were evaporated under reduced pressure and the remaining water was removed with the help of freeze-dry

technique to yield compound **4-1** as a white powder (1.02 g, 93 %). (ATTENTION: all water content must be carefully removed to avoid lousy reactivity of **2** in subsequent reactions). ^1H NMR (400 MHz, DMSO- d_6): δ 7.39 (ddd, $J = 8.1, 7.3, 1.3$ Hz, 2H), 7.46 (ddd, $J = 8.2, 7.3, 1.3$ Hz, 2H), 7.92 (ddd, $J = 8.1, 1.1, 0.6$ Hz, 2H), 8.05 (ddd, $J = 7.9, 1.2, 0.6$ Hz, 2H); ^{13}C $\{^1\text{H}\}$ NMR (101 MHz, DMSO- d_6): δ 194.8, 153.9, 134.9, 125.6, 124.9, 122.9, 122.6.

Preparation of benzo[d]thiazole-2-sulfonyl fluoride (**4-2**)

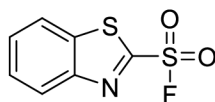

Sulfinic salt (0.5 g, 2.26 mmol, 1 equiv) was suspended in CH_2Cl_2 (23 mL) and the resulting suspension was cooled to 0°C (ice/water). After 5 min at 0°C , a Selecfluor® (1.60 g, 4.52 mmol, 2 equiv) was added in ten portions. After 5 min at 0°C , the mixture was allowed to warm to RT (cooling bath removed), and the resulting mixture was stirred for an additional 30 min at RT. Water (25 mL) was added, and the resulting mixture was extracted with CH_2Cl_2 (3 x 50 mL). Combined organic layers were washed with brine (50 mL), dried over MgSO_4 , filtered, and the solvents were removed under reduced pressure to yield a white crystalline product (0.383 g, 78 %). mp = $94\text{-}96^\circ\text{C}$ (lit. mp = $95\text{-}96^\circ\text{C}$); ^1H NMR (400 MHz, Chloroform- d): δ 8.36 – 8.31 (m, 1H), 8.09 – 8.04 (m, 1H), 7.75 – 7.68 (m, 2H); $^{13}\text{C}\{^1\text{H}\}$ NMR (101 MHz, Chloroform- d): δ 156.3 (d, $J = 38.2$ Hz), 152.1, 137.2, 129.5, 128.6, 126.5, 122.4; $^{19}\text{F}\{^1\text{H}\}$ NMR (376 MHz, Chloroform- d): δ 64.2; MS (ESI) m/z (%) 218: $[\text{M}+\text{H}]^+$ (100); HRMS (ESI) m/z : $[\text{M}+\text{H}]^+$ calcd. for $\text{C}_7\text{H}_5\text{FNO}_2\text{S}_2$, 217.9746; found, 217.9755.

Preparation of BT sulfonamides:

Method A – Oxidative coupling method: Sulfinic salt (0.5 g, 2.22 mmol, 1 equiv) and amine (2.71 mmol, 1.2 equiv) were added to the solvent mixture of THF/EtOH = 4:1 (V/V) (25 mL) at RT. The resulting mixture was stirred at RT for 5 min and NBS (0.800 g, 4.52 mmol, 2 equiv) was added portion wise over a period of 5 min. The reaction mixture turned color to orange upon the NBS addition. After an additional 10 min at RT, the reaction mixture was partitioned between CH_2Cl_2 (25 mL) and water (25 mL). Resulting layers were separated and the aqueous layer was extracted with CH_2Cl_2 (3 x 25 mL). Combined organic layers were washed with brine (25 mL), dried over MgSO_4 , and filtered, and the solvents were evaporated under reduced pressure to provide the crude product.

Method B – (S-N coupling followed by oxidation): Benzo[*d*]thiazole-2-thiol (0.167 g, 1 mmol, 1.0 equiv) and amine (3 mmol, 3.0 equiv) were dissolved in CH₂Cl₂ (5 ml) at RT, and NCS (0.133 g, 1mmol, 1.0 equiv) was added portionwise over the period of 5 min. The resulting mixture was stirred at RT for 30 minutes, before the solvent was removed under reduced pressure. The residue was suspended in EtOH (5 mL) and (NH₄)₆Mo₇O₂₄·4H₂O (0.37 g, 0.3 equiv) was added at once. The resulting mixture was cooled to 0°C (ice/water bath) and a solution of H₂O₂ in water (2 mL, 20 equiv; 30% in water) was added dropwise (AVOID metallic needle). After 30 min at 0°C, the cooling bath was removed, and the reaction mixture was allowed to warm to RT. The progress was monitored by TLC. Resulting mixture was repartitioned between CH₂Cl₂ (25 mL) and H₂O (25 mL). Resulting layers were separated and the aqueous layer was extracted with CH₂Cl₂ (3 x 25 mL). Combined organic layers were washed with brine (25 mL), dried over MgSO₄, filtered, and the solvents were removed under reduced pressure to yield the crude product.

Method C - SuFEx: Sulfonyl fluoride (0.050 g, 0.23 mmol, 1 equiv) was dissolved in CH₃CN (2.3 mL) and amine (0.69 mmol, 3 equiv) was added at RT. The reaction mixture was stirred overnight at RT. Aq. sat. NH₄Cl (10 mL) was added, and the resulting layers were separated. Aqueous layer was extracted with CH₂Cl₂ (3 x 15 mL) and the organic layers were combined, washed with brine (10 mL), dried over MgSO₄, filtered, and the solvents were removed under reduced pressure to yield the crude product.

N-benzylbenzo[*d*]thiazole-2-sulfonamide (4-6a).

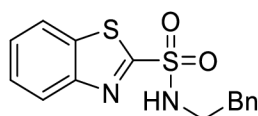

The crude product was purified using flash column chromatography (SiO₂; EtOAc/hexane = 1:4) and obtained as a white solid. Method A: starting from 0.050 g (0.22 mmol) of sulfinic salt, yielded 0.061 g (91%); starting from 2.13 g (10.0 mmol) of sulfinic salt, yielded 2.72 g (90%); Method B: starting from 0.167 g (1.0 mmol) of 2-mercaptobenzothiazole, yielded 0.279 g (92% over two steps); starting from 1.67 g (10.0 mmol) of 1, yielded 2.86 g (94% over two steps); Method C: starting from 0.050 g (0.23 mmol) of 8, yielded 0.032 g (65 %). mp = 108 – 112 °C; ¹H NMR (400 MHz, Chloroform-*d*): δ 8.17 – 8.14 (m, 1H), 7.99 – 7.96 (m, 1H), 7.62 (ddd, *J* = 8.1, 7.2, 1.5 Hz, 1H), 7.57 (ddd, *J* = 7.8, 7.2, 1.4 Hz, 1H), 5.46 (t, *J* = 5.4 Hz, 1H), 4.44 (d, *J* = 6.1 Hz, 2H); ¹³C{¹H} NMR (101 MHz, Chloroform-*d*): δ 166.0, 152.4, 136.5, 135.7,

128.9, 128.3, 128.2, 127.8, 127.6, 125.2, 122.3, 48.2; MS (ESI) m/z (%) 305: $[M+H]^+$ (100); HRMS (ESI) m/z : $[M+H]^+$ calcd. for $C_{14}H_{13}N_2O_2S_2$, 305.0413; found, 305.0412.

N-allylbenzo[*d*]thiazole-2-sulfonamide (4-6b).

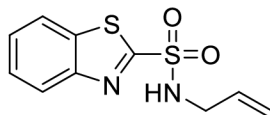

The crude product was purified using flash column chromatography (SiO_2 ; EtOAc/hexane = 1:1) and obtained as a slightly yellow solid. Method A: starting from 0.044 g (0.20 mmol) of sulfinic salt, yielded 0.033 g (65%); Method B: starting from 0.167 g (1.0 mmol) of 2-mercaptobenzothiazole, yielded 0.129 g (51% over two steps); Method C: starting from 0.050 g (0.23 mmol) of sulfonyl fluoride, yielded 0.0292 g (72%). mp = 106 – 110 °C; 1H NMR (400 MHz, Chloroform-*d*): δ 8.16 (ddd, J = 8.2, 1.3, 0.7 Hz, 1H), 7.96 (ddd, J = 7.8, 1.5, 0.7 Hz, 1H), 7.60 (ddd, J = 8.0, 7.2, 1.4 Hz, 1H), 7.55 (ddd, J = 8.1, 7.3, 1.5, 1H), 5.79 (ddt, J = 17.1, 10.2, 5.9 Hz, 1H), 5.46 (t, J = 6.2 Hz, 1H), 5.24 (dq, J = 17.1, 1.5 Hz, 1H), 5.11 (dq, J = 10.2, 1.3 Hz, 1H), 3.88 (tt, J = 6.0, 1.5 Hz, 2H); $^{13}C\{^1H\}$ NMR (101 MHz, Chloroform-*d*): δ 166.1, 152.4, 136.5, 132.5, 127.8, 127.6, 125.2, 122.3, 118.5, 46.5; MS (ESI) m/z (%) 255: $[M+H]^+$ (100); HRMS (ESI) m/z : $[M+H]^+$ calcd. for $C_{10}H_{11}N_2O_2S_2$, 255.0256; found, 255.0257.

N-butyl benzo[*d*]thiazole-2-sulfonamide (4-6c).

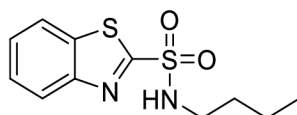

The crude product was purified using flash column chromatography (SiO_2 ; EtOAc/hexane = 1:3) and obtained as colorless oil. Method A: starting from 0.044 g (0.20 mmol) of sulfinic salt, yielded 0.036 g (67%); Method B: starting from 0.167 g (1.0 mmol) of 2-mercaptobenzothiazole, yielded 0.178 g (66% over two steps); Method C: starting from 0.050 g (0.23 mmol) of sulfonyl fluoride, yielded 0.035 g (56%). 1H NMR (400 MHz, Chloroform-*d*): δ 8.18 – 8.16 (m, 1H), 7.99 – 7.96 (m, 1H), 7.56 (ddd, J = 8.1, 7.2, 1.4 Hz, 1H), 7.61 (ddd, J = 8.2, 7.2, 1.4 Hz, 1H), 5.18 (t, J = 6.0 Hz, 1H), 3.25 (td, J = 7.1, 6.1 Hz, 2H), 1.58 – 1.51 (m, 2H), 1.40 – 1.30 (m, 2H), 0.88 (t, J = 7.4 Hz, 3H); $^{13}C\{^1H\}$ NMR (101 MHz, Chloroform-*d*): δ 166.2, 152.5, 136.6, 127.7, 127.6, 125.2, 122.3, 43.9, 31.9, 19.7, 13.6; MS (ESI) m/z (%) 271: $[M+H]^+$ (100); HRMS (ESI) m/z : $[M+H]^+$ calcd. for $C_{11}H_{15}N_2O_2S_2$, 271.0569; found, 271.0569.

N-(furan-2-ylmethyl)benzo[*d*]thiazole-2-sulfonamide (4-6d).

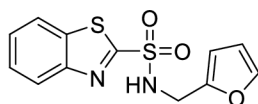

The crude product was purified using flash column chromatography (SiO₂; EtOAc/hexane = 1:1) and obtained as colorless oil. Method B: starting from 0.167 g (1.0 mmol) of 2-mercaptobenzothiazole, yielded 0.114 g (39% over two steps); Method C: starting from 0.050 g (0.23 mmol) of sulfonyl fluoride, yielded 0.031 g (45%). ¹H NMR (400 MHz, Chloroform-*d*): δ 8.14 – 8.13 (m, 1H), 7.97 – 7.96 (m, 1H), 7.56 (ddd, *J* = 8.3, 7.3, 1.3 Hz, 1H), 7.61 (ddd, *J* = 8.3, 7.2, 1.3 Hz, 1H), 7.17 (m, 1H), 6.16 (dd, *J* = 3.1, 0.7 Hz, 1H), 6.13 (dd, *J* = 3.2, 1.9 Hz, 1H), 5.56 – 5.54 (m, 1H), 4.46 (d, *J* = 6.0 Hz, 2H); ¹³C{¹H} NMR (126 MHz, Chloroform-*d*): δ 165.9, 152.5, 148.9, 143.0, 136.5, 127.8, 127.6, 125.2, 122.3, 110.5, 108.9, 40.9; MS (ESI) *m/z* (%) 295: [M+H]⁺ (100); HRMS (ESI) *m/z*: [M+K]⁺ calcd. for C₁₂H₁₀KN₂O₃S₂, 332.9764; found, 332.9767.

N-(1-(4-chlorophenyl)ethyl)benzo[*d*]thiazole-2-sulfonamide (4-6e).

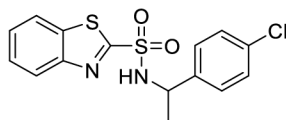

The crude product was purified using flash column chromatography (SiO₂; EtOAc/hexane = 1:10) and obtained as a colorless oil. Method A: starting from 0.044 g (1.0 mmol) of sulfinic salt, yielded 0.052 g (74%); Method C: starting from 0.050 g (0.23 mmol) of sulfonyl fluoride, yielded 0.0196 g (24%). ¹H NMR (400 MHz, Chloroform-*d*): δ 8.07 (ddd, *J* = 8.2, 1.3, 0.6 Hz, 1H), 7.92 (ddd, *J* = 7.8, 1.3, 0.6 Hz, 1H), 7.60 (ddd, *J* = 8.2, 7.2, 1.4 Hz, 1H), 7.55 (ddd, *J* = 8.4, 7.3, 1.3 Hz, 2H), 7.12 (dt, *J* = 8.8, 2.0 Hz, 2H), 7.05 (dt, *J* = 8.9, 2.4 Hz, 2H), 5.74 (d, *J* = 7.4 Hz, 1H), 4.77 (p, *J* = 7.0 Hz, 1H), 1.53 (d, *J* = 6.9 Hz, 3H); ¹³C{¹H} NMR (101 MHz, Chloroform-*d*): δ 166.5, 152.2, 139.8, 136.5, 133.7, 128.7, 127.8, 127.7, 127.5, 125.0, 122.1, 54.2, 23.2; MS (ESI) *m/z* (%) 351: [M+H]⁺ (100); HRMS (ESI) *m/z*: [M+H]⁺ calcd. for C₁₅H₁₄ClN₂O₂S₂, 353.0180; found, 353.0178.

2-(piperidin-1-ylsulfonyl)benzo[d]thiazole (4-6f).

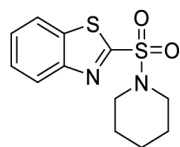

The crude product was purified using flash column chromatography (SiO₂; EtOAc/CHCl₃ = 1:1 -> 0:1) and obtained as a white solid. Method A: starting from 0.044 g (0.20 mmol) of sulfinic salt, yielded 0.031 g (55%). Method C: starting from 0.050 g (0.23 mmol) of sulfonyl fluoride, yielded 0.0156 g (24%). mp = 109 – 113 °C; ¹H NMR (400 MHz, Chloroform-*d*): δ 8.20 (ddd, *J* = 8.2, 1.3, 0.7 Hz, 1H), 7.98 (ddd, *J* = 7.9, 1.4, 0.7 Hz, 1H), 7.61 (ddd, *J* = 8.2, 7.2, 1.4 Hz, 1H), 7.56 (ddd, *J* = 7.9, 7.2, 1.4 Hz, 1H), 3.40 – 3.37 (m, 4H), 1.71 – 1.66 (m, 4H), 1.56 – 1.50 (m, 2H); ¹³C{¹H} NMR (101 MHz, Chloroform-*d*): δ 164.6, 152.8, 136.4, 127.6, 127.4, 125.3, 122.2, 47.6, 25.4, 23.6; MS (ESI) *m/z* (%) 283: [M+H]⁺ (100); HRMS (ESI) *m/z*: [M+H]⁺ calcd. for C₁₂H₁₅N₂O₂S₂, 283.0569; found, 283.0570.

N-cyclohexyl-*N*-methylbenzo[d]thiazole-2-sulfonamide (4-6g).

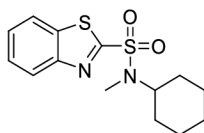

The crude product was purified using flash column chromatography (SiO₂; EtOAc/hexane = 1:3) and obtained as a white solid. Method B: starting from 0.167 g (1.0 mmol) of 2-mercaptobenzothiazole, yielded 0.107 g (34%); Method C: starting from 0.050 g (0.23 mmol) of sulfonyl fluoride, yielded 0.011 g (22%). mp = 80 – 82 °C; ¹H NMR (400 MHz, Chloroform-*d*): δ 8.18 – 8.16 (m, 1H), 7.97 – 7.95 (m, 1H), 7.59 (ddd, *J* = 8.3, 7.2, 1.4 Hz, 1H), 7.56 – 7.52 (m, 1H), 3.98 (tt, *J* = 11.6, 3.8 Hz, 1H), 2.98 (s, 3H), 1.77 – 1.59 (m, 5H), 1.43 – 1.29 (m, 4H), 1.07 – 0.98 (m, 1H); ¹³C{¹H} NMR (101 MHz, Chloroform-*d*): δ 166.4, 152.8, 136.4, 127.5, 127.4, 125.3, 122.2, 58.1, 30.6, 29.5, 25.8, 25.4; MS (ESI) *m/z* (%) 311: [M+H]⁺ (100); HRMS (ESI) *m/z*: [M+K]⁺ calcd. for C₁₄H₁₉N₂O₂S₂, 311.0882; found, 311.0886.

(+)-*N*-((1*R*,2*R*)-2-(benzo[*d*]thiazole-2-sulfonamido)cyclohexyl)benzo[*d*]thiazole-2-sulfonamide ((4-6*h*)).

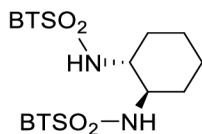

The crude product was purified using flash column chromatography (SiO₂; EtOAc/hexane = 1:5->1:3) and obtained as a viscose syrup. Method A: starting from 0.100 g (0.452 mmol, 2.2 equiv) of sulfinic salt, and (1*R*,2*R*)-cyclohexane-1,2-diamine (0.0235 g, 0.205 mmol, 1.0 equiv); yielded 0.031 g (30%). $[\alpha]_D^{21} = -5.63^\circ$ (*c* 0.16, CH₂Cl₂); ¹H NMR (400 MHz, Chloroform-*d*): δ 9.43 (d, *J* = 3.2 Hz, 2H), 8.31 (dt, *J* = 8.3, 1.0 Hz, 2H), 7.95 – 7.89 (m, 2H), 7.61 (ddd, *J* = 8.4, 7.2, 1.3 Hz, 2H), 7.54 (ddd, *J* = 8.4, 7.2, 1.3 Hz, 2H), 3.58 – 3.49 (m, 2H), 2.49 (dt, *J* = 14.0, 2.7 Hz, 2H), 1.79 – 1.67 (m, 2H), 1.64 – 1.45 (m, 4H); ¹³C{¹H} NMR (101 MHz, Chloroform-*d*): δ 168.6, 149.8, 136.1, 128.2, 128.13, 125.2, 122.3, 57.8, 35.9, 24.4; MS (ESI) *m/z* (%) 510: [M+H]⁺ (100); HRMS (ESI) *m/z*: [M+K]⁺ calcd. for C₂₀H₂₁N₄O₄S₄, 509.0440; found, 509.0442.

tert-butyl (2-(benzo[*d*]thiazole-2-sulfonamido)ethyl)carbamate (4-6*i*).

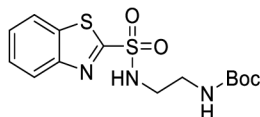

The crude product was purified using flash column chromatography (SiO₂; EtOAc/hexane = 2:3) and obtained as a white solid. Method A: starting from 0.221 g (1.0 mmol) of sulfinic salt, yielded 0.172 g (67%). mp = 142 – 146 °C; ¹H NMR (400 MHz, Chloroform-*d*): δ 8.17 (ddd, *J* = 8.3, 1.5, 0.7 Hz, 1H), 7.97 (ddd, *J* = 7.6, 1.3, 0.6 Hz, 1H), 7.61 (ddd, *J* = 7.9, 7.2, 1.4 Hz, 1H), 7.56 (ddd, *J* = 7.9, 7.2, 1.5 Hz, 1H), 6.01 (bs, 1H), 5.05 (t, *J* = 5.2 Hz, 1H), 3.44 – 3.41 (m, 2H), 3.44 – 3.30 (m, 2H), 1.39 (s, 9H); ¹³C{¹H} NMR (101 MHz, Chloroform-*d*): δ 166.3, 156.7, 152.3, 136.5, 127.7, 127.5, 125.2, 122.3, 80.2, 44.8, 40.4, 28.4; MS (ESI) *m/z* (%) 356: [M+H]⁺ (100); HRMS (ESI) *m/z* [M+K]⁺ calcd. for C₁₄H₁₉N₃O₄S₂K, 396.0449; found, 396.0452.

N-(benzo[*d*][1,3]dioxol-5-ylmethyl)benzo[*d*]thiazole-2-sulfonamide (4-6r).

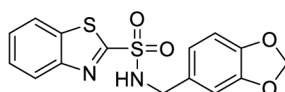

The crude product was purified using flash column chromatography (SiO₂; EtOAc/hexane = 3:4) and obtained as a white solid. Method B: starting from 0.167 g (1.0 mmol) of 2-mercaptobenzothiazole, yielded 0.150 g (43% over two steps). mp = 140 – 141 °C; ¹H NMR (400 MHz, Chloroform-*d*): δ 8.14 (d, *J* = 8.1 Hz, 1H), 7.97 (d, *J* = 8.3 Hz, 1H), 7.61 (dt, *J* = 7.2, 1.1 Hz), 7.56 (dt, *J* = 8.1, 1.4 Hz, 1H), 7.59 - 7.54 (m, 1H), 6.76 (s, 1H), 6.72 (d, *J* = 8.6 Hz, 1H), 6.65 (d, *J* = 8.6 Hz, 1H), 5.84 (s, 2H), 5.76 – 5.60 (bs, 1H), 4.32 (d, *J* = 5.5 Hz, 1H); ¹³C{¹H} NMR (101 MHz, Chloroform-*d*): δ 166.3, 152.4, 148.1, 147.6, 136.5, 129.5, 127.7, 127.6, 125.2, 122.3, 121.9, 108.8, 108.4, 101.3, 48.0; MS (ESI) *m/z* (%) 349: [M+H]⁺ (100); HRMS (ESI) *m/z*: [M+H]⁺ calcd. for C₁₅H₁₃N₂O₄S₂, 349.0311; found, 349.0307.

N-(1-(naphthalen-1-yl)ethyl)benzo[*d*]thiazole-2-sulfonamide (4-6j).

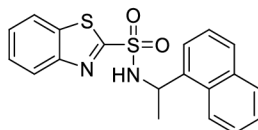

The crude product was purified using flash column chromatography (SiO₂; EtOAc/hexane = 1:3) and obtained as a colorless oil. Method A: starting from 0.050 g (0.226 mmol) of sulfinic salt, yielded 0.029 g (36%). ¹H NMR (400 MHz, Chloroform-*d*): δ 8.02 – 7.98 (m, 2H), 7.84 - 7.82 (m, 1H), 7.75 - 7.71 (m, 1H), 7.61 (d, *J* = 8.2 Hz, 1H), 7.56 – 7.48 (m, 2H), 7.44 (dd, *J* = 7.2, 1.1 Hz, 1H), 7.42 – 7.36 (m, 2H), 7.24 (dd, *J* = 8.2, 7.3 Hz, 1H), 5.65 – 5.63 (m, 1H), 1.72 (d, *J* = 6.5 Hz, 1H); ¹³C{¹H} NMR (101 MHz, Chloroform-*d*): δ 166.5, 152.3, 137.1, 136.6, 133.9, 130.2, 128.9, 128.6, 127.6, 127.4, 126.6, 125.9, 125.2, 125.1, 123.6, 122.7, 122.1, 50.9, 23.2; MS (ESI) *m/z* (%) 370: [M+H]⁺ (100); HRMS (ESI) *m/z*: [M+H]⁺ calcd. for C₁₉H₁₇N₂O₄S₂, 369.0726; found, 369.0734.

(-)-(S)-N-(1-hydroxy-3-methylbutan-2-yl)benzo[d]thiazole-2-sulfonamide (4-6k).

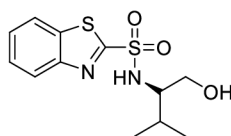

The crude product was purified using flash column chromatography (SiO₂; EtOAc/hexane = 1:1) and obtained as colorless oil. Method A: starting from 0.044 g (0.20 mmol) of sulfinic salt, yielded 0.038 g (64%); Method B: starting from 0.167 g (1.0 mmol) of 2-mercaptobenzothiazole, yielded 0.135 g (45% over two steps). [α]_D²¹ = -335° (c 0.2, MeOH); ¹H NMR (400 MHz, Chloroform-*d*): δ 8.11 (ddd, *J* = 7.4, 1.6, 0.5 Hz, 1H), 7.98 – 7.96 (m, 1H), 7.62 – 7.54 (m, 2H), 5.25 (d, *J* = 8.3 Hz, 1H), 3.74 – 3.65 (m, 2H), 3.58 – 3.52 (m, 1H), 3.10 (t, *J* = 5.9 Hz, 1H), 1.94 (oct, *J* = 6.8 Hz, 1H), 0.99 (d, *J* = 6.8 Hz, 6H); ¹³C{¹H} NMR (101 MHz, Chloroform-*d*): δ 167.9, 151.5, 136.3, 127.8, 127.7, 124.9, 122.3, 62.9, 30.4, 19.3, 18.6; MS (ESI) *m/z* (%) 301: [M+H]⁺ (100); HRMS (ESI) *m/z*: [M+H]⁺ calcd. for C₁₂H₁₇N₂O₃S₂, 301.0675; found, 301.0677.

(-)-N-(2-hydroxy-1-phenylethyl)benzo[d]thiazole-2-sulfonamide (4-6l).

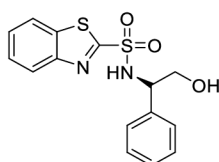

The crude product was purified using flash column chromatography (SiO₂; EtOAc/hexane = 4:5) and obtained as a white solid. Method A: starting from 0.044 g (0.20 mmol) of sulfinic salt, yielded 0.024 g (37%); Method B: starting from 0.167 g (1.0 mmol) of 2-mercaptobenzothiazole, yielded 0.160 g (47% over two steps). mp = 118–120 °C); [α]_D²³ = -144° (c 0.25, CH₂Cl₂); ¹H NMR (400 MHz, Chloroform-*d*): δ 8.07 (ddd, *J* = 7.9, 1.5, 0.5 Hz, 1H), 7.90 (ddd, *J* = 7.5, 1.5, 0.6 Hz, 1H), 7.60 – 7.51 (m, 2H), 7.27 – 7.25 (m, 2H), 7.22 – 7.13 (m, 3H), 4.84 (dd, *J* = 6.3, 4.3 Hz, 1H), 3.94 (dd, *J* = 11.7, 4.3 Hz, 1H), 3.86 (dd, *J* = 11.7, 6.4 Hz, 1H); ¹³C{¹H} NMR (101 MHz, Chloroform-*d*): δ 167.0, 151.8, 137.6, 136.5, 128.8, 128.3, 127.8, 127.6, 127.0, 125.0, 122.2, 66.1, 60.5; MS (ESI) *m/z* (%) 335: [M+H]⁺ (100); HRMS (ESI) *m/z*: [M+H]⁺ calcd. for C₁₅H₁₅N₂O₃S₂, 335.0519; found, 335.0516.

1-(benzo[d]thiazol-2-ylsulfonyl)piperidin-4-ol (4-6m).

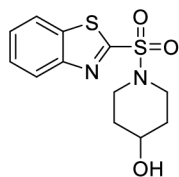

The crude product was purified using flash column chromatography (SiO₂; EtOAc/hexane = 1:1 -> 4:3 -> 8:3) and obtained as a colorless oil. Method A: starting from 0.044 g (0.20 mmol) of sulfinic salt, yielded 0.045 g (76%). ¹H NMR (400 MHz, Chloroform-*d*): δ 8.20 - 8.17 (m, 1H), 7.99 - 7.96 (m, 1H), 7.63 - 7.54 (m, 2 H), 3.91 - 3.86 (m, 1H), 3.71 - 3.64 (m, 2H), 3.34 - 3.28 (m, 2H), 2.00 - 1.94 (m, 2H), 1.72 - 1.68 (m, 2H); ¹³C{¹H} NMR (101 MHz, Chloroform-*d*): δ 164.1, 152.8, 136.4, 127.7, 127.5, 125.4, 122.2, 65.8, 43.7, 33.4; MS (ESI) *m/z* (%) 290: [M+H]⁺ (100); HRMS (ESI) *m/z*, [M+H]⁺ calcd. for C₁₂H₁₅N₂O₃S₂, 299.0519; found, 299.0521.

(S)-diethyl (benzo[d]thiazol-2-ylsulfonyl)glutamate (4-6n).

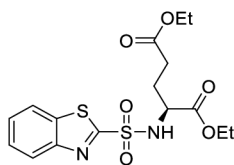

Method B (method was slightly modified since hydrochloride salt was used): L-glutamate hydrochloride (0.215 g, 0.9 mmol) was suspended in CH₂Cl₂ (3 mL) at RT, and Et₃N (0.125 mL, 0.9 mmol, 9 equiv) followed with 2-mercaptobenzothiazole (0.050 g, 0.3 mmol, 3 equiv) were added. After 5 min at RT, *N*-chlorosuccinimide (0.040 g, 0.3 mmol, 3.0 equiv) was added, and the resulting mixture was stirred at RT for 2 hours. CH₂Cl₂ (20 mL) and H₂O (20 mL) were added, and the resulting layers were separated. Aqueous layer was extracted with CH₂Cl₂ (3 x 15 mL) and the combined organic layers were washed with brine (10 mL), dried over MgSO₄, filtered, and the solvents were removed under reduced pressure. The residue was suspended in EtOH (2 mL) and (NH₄)₆M₇O₄ x 4H₂O (0.123 g, 0.1 mmol, 0.1 equiv) was added. The resulting slurry was cooled to 0 °C (ice/water) and H₂O₂ in water (0.610 mL, 20 equiv; 30% in water) was added dropwise. The resulting mixture was stirred at 0 °C for 5 min before the cooling bath was removed. After 12h at RT, the whole mixture was diluted with CH₂Cl₂ (20 mL) and H₂O (20 mL) and the resulting layers were separated. The aqueous layer was extracted with CH₂Cl₂

(3 x 15 mL), and combined organic layers were washed with brine (15 mL), dried over MgSO₄, filtered, and the solvents were removed under reduced pressure. The purification of the crude product using flash column chromatography (SiO₂; EtOAc/petroleum ether = 1:3) yielded 0.114 g (66 % over two steps) of viscose syrup. $[\alpha]_D^{20} = -112^\circ$ (*c* 0.44, CH₂Cl₂); ¹H NMR (400 MHz, Chloroform-*d*): δ 8.11 (ddd, *J* = 8.2, 1.6, 0.6 Hz, 1H), 7.97 (ddd, *J* = 7.7, 1.6, 0.7 Hz, 1H), 7.62 – 7.53 (m, 2H), 5.80 (bs, 1H), 4.47 (dd, *J* = 8.8, 4.6 Hz, 1H), 4.13 (q, *J* = 7.1 Hz, 2H), 4.04 – 3.98 (m, 2H), 2.60 – 2.46 (m, 2H), 2.25 (dtd, *J* = 14.2, 7.5, 4.7 Hz, 1H), 2.00 (dddd, *J* = 14.3, 8.8, 7.8, 6.4 Hz, 1H), 1.25 (t, *J* = 7.2 Hz, 3H), 1.12 (t, *J* = 7.1 Hz, 3H); ¹³C{¹H} NMR (101 MHz, Chloroform-*d*): δ 172.7, 171.0, 165.7, 152.4, 136.5, 127.8, 127.6, 125.1, 122.3, 62.3, 60.9, 56.3, 30.0, 28.5, 14.3, 14.1; MS (ESI) *m/z* (%) 401: [M+H]⁺ (100); HRMS (ESI) *m/z*: [M+K]⁺ calcd. for C₁₆H₂₀KN₂O₆S₂, 439.0394; found, 439.0396.

(-)-Methyl (benzo[*d*]thiazol-2-ylsulfonyl)-L-phenylalaninate (4-6o).

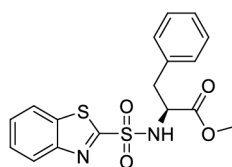

Method B (method was slightly modified since hydrochloride salt was used): Methyl L-phenylalaninate hydrochloride (0.193 g, 0.9 mmol) was suspended in CH₂Cl₂ (3 mL) at RT, and Et₃N (0.125 mL, 0.9 mmol, 9 equiv) followed with 2-mercaptobenzothiazole (0.050 g, 0.3 mmol, 3 equiv) were added. After 5 min at RT, *N*-chlorosuccinimide (0.040 g, 0.3 mmol, 3.0 equiv) was added, and the resulting mixture was stirred at RT for 2 hours. CH₂Cl₂ (20 mL) and H₂O (20 mL) were added, and the resulting layers were separated. Aqueous layer was extracted with CH₂Cl₂ (3 x 15 mL) and the combined organic layers were washed with brine (10 mL), dried over MgSO₄, filtered, and the solvents were removed under reduced pressure. The residue was suspended in EtOH (2 mL) and (NH₄)₆M₇O₄ x 4H₂O (0.123 g, 0.1 mmol, 0.1 equiv) was added. The resulting slurry was cooled to 0 °C (ice/water) and H₂O₂ in water (0.610 mL, 20 equiv; 30% in water) was added dropwise. The resulting mixture was stirred at 0 °C for 5 min before the cooling bath was removed. After 12h at RT, the whole mixture was diluted with CH₂Cl₂ (20 mL) and H₂O (20 mL) and the resulting layers were separated. The aqueous layer was extracted with CH₂Cl₂ (3 x 15 mL), and combined organic layers were washed with brine (15 mL), dried over MgSO₄, filtered, and the solvents were removed under reduced pressure. The purification of the crude product using flash column chromatography (SiO₂; EtOAc/petroleum ether = 1:3) yielded 0.27 g (80 % over two steps) of viscose syrup. $[\alpha]_D^{23} =$

–129° (*c* 0.51, CH₂Cl₂); ¹H NMR (400 MHz, Chloroform-*d*): δ 8.12 (ddd, *J* = 7.9, 1.7, 0.6 Hz, 1H), 7.95 (ddd, *J* = 7.7, 1.5, 0.6 Hz, 1H), 7.60 (ddd, *J* = 8.2, 7.2, 1.5 Hz, 1H), 7.55 (ddd, *J* = 7.9, 7.2, 1.4 Hz, 1H), 7.26 – 7.14 (m, 3H), 7.11 – 7.09 (m, 2H), 5.58 (bs, 1H), 4.72 (t, *J* = 5.8 Hz, 1H), 3.55 (s, 3H), 3.19 (dd, *J* = 13.9, 5.7 Hz, 1H), 3.13 (dd, *J* = 13.9, 5.9 Hz, 1H); ¹³C{¹H} NMR (101 MHz, Chloroform-*d*): δ 170.9, 165.6, 152.4, 136.5, 134.7, 129.5, 128.7, 127.8, 127.5, 127.4, 125.2, 122.3, 57.6, 52.7, 39.5; MS (ESI) *m/z* (%) 377: [M+H]⁺ (100); HRMS (ESI) *m/z*: [M+H]⁺ calcd. for C₁₇H₁₇N₂O₄S₂, 377.0624; found, 377.0627.

(–)-Methyl (benzo[*d*]thiazol-2-ylsulfonyl)alaninate (4-6p).

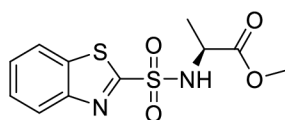

Method B (method was slightly modified since hydrochloride salt was used): Methyl alaninate hydrochloride (0.125 g, 0.9 mmol) was suspended in CH₂Cl₂ (3 mL) at RT, and Et₃N (0.125 mL, 0.9 mmol, 9 equiv) followed with 2-mercaptobenzothiazole (0.050 g, 0.3 mmol, 3 equiv) were added. After 5 min at RT, *N*-chlorosuccinimide (0.040 g, 0.3 mmol, 3.0 equiv) was added, and the resulting mixture was stirred at RT for 2 hours. CH₂Cl₂ (20 mL) and H₂O (20 mL) were added, and the resulting layers were separated. Aqueous layer was extracted with CH₂Cl₂ (3 x 15 mL) and the combined organic layers were washed with brine (10 mL), dried over MgSO₄, filtered, and the solvents were removed under reduced pressure. The residue was suspended in EtOH (2 mL) and (NH₄)₆M₇O₄ x 4H₂O (0.123 g, 0.1 mmol, 0.1 equiv) was added. The resulting slurry was cooled to 0 °C (ice/water) and H₂O₂ in water (0.610 mL, 20 equiv; 30% in water) was added dropwise. The resulting mixture was stirred at 0 °C for 5 min before the cooling bath was removed. After 12h at RT, the whole mixture was diluted with CH₂Cl₂ (20 mL) and H₂O (20 mL) and the resulting layers were separated. The aqueous layer was extracted with CH₂Cl₂ (3 x 15 mL), and combined organic layers were washed with brine (15 mL), dried over MgSO₄, filtered, and the solvents were removed under reduced pressure. The purification of the crude product using flash column chromatography (SiO₂; EtOAc/petroleum ether = 1:3) yielded 0.059 g (66 % over two steps) of viscose syrup. [α]_D²⁰ = –18.2° (*c* 0.45, CHCl₃); ¹H NMR (400 MHz, Chloroform-*d*): δ 8.14 (ddd, *J* = 8.3, 1.3, 0.6 Hz, 1H), 7.97 (ddd, *J* = 7.7, 1.4, 0.6 Hz, 1H), 7.58 – 7.65 (m, 1H), 7.50 – 7.60 (m, 1H), 5.84 (bs, 1H), 4.48 (bs, 1H), 3.61 (s, 3H), 1.51 (d, *J* = 7.2 Hz, 3H); ¹³C{¹H} NMR (101 MHz, Chloroform-*d*): δ 172.4, 165.9, 152.4, 136.5, 127.8, 127.6,

125.2, 122.4, 53.0, 52.6, 20.1; MS (ESI) m/z (%) 301: $[M+H]^+$ (100); HRMS (ESI) m/z : $[M+K]^+$ calc. for $C_{11}H_{12}KN_2O_4S_2$, 338.9870; found, 338.9873.

Synthesis of fully protected amino alcohols

3-(N-(benzo[d]thiazol-2-ylsulfonyl)acetamido)propyl acetate (4-75)

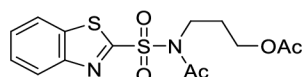

Prepared using the Method A from **2** (0.100 g, 0.45 mmol). The crude product obtained using the Method A was dissolved in pyridine (2 mL) and Ac_2O (0.128 mL, 1.35 mmol, 3.0 equiv) was added at RT. The resulting mixture was stirred for 12h at RT before sat. aq. NH_4Cl (5 mL) was added. The resulting mixture was extracted with EtOAc (3 x 15 mL) and the resulting organic layers were combined and washed with brine (10 mL), dried over $MgSO_4$, filtered, and the solvents were removed under reduced pressure. The crude product was purified by flash column chromatography (SiO_2 ; EtOAc:hexane = 1:2) to yield 0.113 g (71 % over two steps) of colorless oil. 1H NMR (400 MHz, Chloroform-*d*): δ 8.18 – 8.16 (m, 1H), 8.00 – 7.98 (m, 1H), 7.66 – 7.58 (m, 2H), 4.13 (t, J = 6.1 Hz, 2H), 4.00 – 3.96 (m, 2H), 2.58 (s, 3H), 2.11 – 2.08 (m, 2H), 2.04 (s, 3H); ^{13}C { 1H } NMR (101 MHz, Chloroform-*d*): δ 171.2, 170.5, 164.1, 152.1, 136.6, 128.5, 128.0, 125.7, 122.3, 61.9, 45.1, 28.8, 25.6, 21.1; MS (ESI) m/z (%) 357: $[M+H]^+$ (100); HRMS (ESI) m/z $[M+H]^+$ calcd. for $C_{14}H_{17}N_2O_5S_2$, 357.0573; found, 357.0576.

N-(benzo[d]thiazol-2-ylsulfonyl)-N-(6-((tert-butyl)dimethylsilyloxy)hexyl)acetamide (4-77)

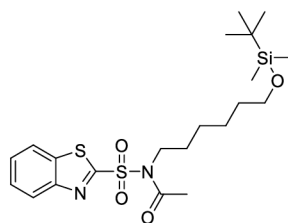

Prepared using the Method A from sulfinic salt (0.100 g, 0.45 mmol). The crude product obtained using the Method A was dissolved in DMF (9 mL) at RT, and imidazole (0.183 g, 2.7 mmol, 6 equiv) was added. After 5 min at RT, TBSCl (0.202 g, 1.35 mmol, 3.0 equiv) was added and the resulting mixture was stirred at RT for 12h. The solvent was removed from the reaction mixture by freeze-drying technique. The crude product was suspended in pyridine (4

mL) and Ac₂O (0.127 ml, 1.35 mmol, 3.0 equiv) was added at RT. The resulting mixture was stirred for an additional 12h before sat. aq. NH₄Cl (10 mL) was added. The resulting mixture was extracted with CH₂Cl₂ (3 x 15 mL), and the resulting organic layers were combined, washed with brine (10 mL), dried over MgSO₄, filtered, and the solvents were removed under reduced pressure. The crude product was purified by flash column chromatography (SiO₂; EtOAc:hexane = 1:3) to yield 0.279 g (66 % over 3 steps) of a colorless oil. ¹H NMR (400 MHz, Chloroform-*d*): δ 8.17 (dd, *J* = 7.6, 1.6 Hz, 1H), 7.99 (dd, *J* = 7.5, 1.7 Hz, 1H), 7.65 – 7.57 (m, 2H), 3.87 – 3.84 (m, 2H), 3.58 (t, *J* = 6.5 Hz, 1H), 2.58 (s, 3H), 1.78 – 1.70 (m, 2H), 1.53 – 1.46 (m, 2H), 1.36 – 1.32 (m, 4H), 0.89 – 0.88 (m, 9H), 0.04 – 0.03 (m, 6H); ¹³C{¹H} NMR (101 MHz, Chloroform-*d*): δ 170.5, 164.5, 152.1, 136.7, 128.3, 127.9, 125.6, 122.3, 63.2, 47.9, 32.8, 29.7, 26.6, 26.1, 25.6, 25.5, 18.5, -5.2; MS (ESI) *m/z* (%) 472: [M+H]⁺ (100); HRMS (ESI) *m/z*: [M+H]⁺ calcd. for C₂₁H₃₅N₂O₄S₂Si, 471.1802; found, 417.1805.

N-alkylation of N-monosubstituted sulfonamides:

General procedure for Fukuyama-Mitsunobu alkylation (FM alkylation): A sulfonamide (0.18 mmol, 1.0 equiv) was dissolved in dry THF (4.5 mL) at RT in the 10 mL microwave vial, and alcohol (0.36 mmol, 2 equiv), PPh₃ (0.070 g, 0.27 mmol, 1.5 equiv) and DIAD (0.052 mL, 0.27 mmol, 1.5 equiv) were successfully added. The microwave vial was placed in the microwave reactor and heated for 10 min at 50 °C (100 W power). The resulting reaction mixture was placed to a 25 mL flask and the solvents were removed under reduced pressure to yield the crude product.

General procedure for base-promoted alkylation using alkyl halides (base-promoted alkylation): A sulfonamide (0.098 mmol, 1.0 equiv) was added to DMF (2 mL) at RT. The whole mixture was cooled to 0 °C and alkyl halide (0.196 mmol, 2.0 equiv) followed by the addition of K₂CO₃ (0.196 mmol, 2.0 equiv) were added. The resulting mixture was stirred at 0 °C for 5 min. The cooling bath was removed and the whole mixture was stirred at for 12h at rt (for primary alkyl halides) or at 50 °C (for secondary alkyl halides; external temperature, oil bath). Sat. aq. NH₄Cl (10 mL) was added and the resulting mixture was extracted with CH₂Cl₂ (3 x 15 mL). Combined organic layers were washed with brine (10 mL), dried over MgSO₄, filtered, and the solvents were removed under reduced pressure to give the crude product.

N,N-dibenzylbenzo[*d*]thiazole-2-sulfonamide (4-6aa).

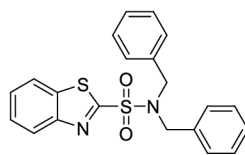

The crude product was purified using flash column chromatography (SiO₂; EtOAc/hexane = 1:3) and obtained as a colorless oil. FM alkylation: starting from 0.070 g (0.23 mmol) of 4-6a, yielded 0.065 g (72%); Base-promoted alkylation: starting from 0.030 g (0.09 mmol) 4-6a, carried out at RT, yielded 0.031 g (81%). ¹H NMR (400 MHz, Chloroform-*d*): δ 8.17 (ddd, J = 8.3, 1.2, 0.5 Hz, 1H), 7.97 (ddd, J = 7.9, 1.3, 0.5 Hz, 1H), 7.62 (ddd, J = 8.2, 7.3, 1.4 Hz, 1H), 7.57 (ddd, J = 7.9, 7.2, 1.3 Hz, 1H), 7.21 – 7.15 (m, 10H), 4.55 (s, 4H); ¹³C{¹H} NMR (101 MHz, Chloroform-*d*): δ 166.4, 152.5, 136.3, 134.9, 128.9, 128.6, 128.0, 127.6, 127.4, 125.2, 122.2, 51.5; MS (ESI) *m/z* (%) 395: [M+H]⁺ (100); HRMS (ESI) *m/z*: [M+H]⁺ calcd. for C₂₁H₁₉N₂O₂S₂, 395.0882; found, 395.0885.

N-benzyl-*N*-isopropylbenzo[*d*]thiazole-2-sulfonamide (4-6ab).

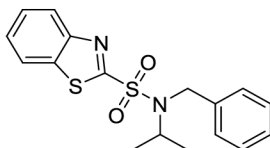

The crude product was purified using flash column chromatography (SiO₂; EtOAc/hexane = 1:3) and obtained as a colorless oil. FM alkylation: starting from 0.030 g (0.09 mmol) of 4-6a, yielded 0.030 g (90%); Base-promoted alkylation: starting from 0.030 g (0.09 mmol) of 4-6a, carried out at 50 °C, yielded 0.032 g (97%). ¹H NMR (400 MHz, Chloroform-*d*): δ 8.18 - 8.17 (m, 1H), 7.97 - 7.95 (m, 1H), 7.62 - 7.58 (m, 1H), 7.56 - 7.52 (m, 1H), 7.46 - 7.44 (m, 2H), 7.34 - 7.24 (m, 3H), 4.61 (s, 2H), 4.39 (hept, *J* = 6.8 Hz, 1H), 1.06 (d, *J* = 6.8 Hz, 6H); ¹³C{¹H} NMR (101 MHz, Chloroform-*d*): δ 166.9, 152.7, 138.1, 136.5, 128.6, 128.0, 127.7, 127.6, 127.4, 125.3, 122.2, 51.8, 48.0, 21.5; MS (ESI) *m/z* (%) 347: [M+H]⁺ (100); HRMS (ESI) *m/z*: [M+H]⁺ calcd. for C₁₇H₁₉N₂O₂S₂, 347.0882; found, 347.0884.

N-benzyl-*N*-(2-methylallyl)benzo[*d*]thiazole-2-sulfonamide (4-6ac).

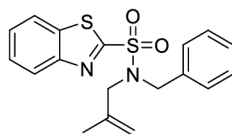

The crude product was purified using flash column chromatography (SiO₂; EtOAc/hexane = 1:6->1:3) and obtained as a colorless oil. FM alkylation: starting from 0.055 g (0.18 mmol) of 4-6a, yielded 0.026 g (40%); Base-promoted alkylation: starting from 0.055 g (0.18 mmol) of 4-6a, carried out at RT, yielded 0.056 g (87%). ¹H NMR (400 MHz, Chloroform-*d*): δ 8.17 (ddd, *J* = 8.5, 1.3, 0.7 Hz, 2H), 7.96 (ddd, *J* = 7.9, 1.3, 0.6 Hz, 1H), 7.63 - 7.59 (m, 1H), 7.58 - 7.53 (m, 1H), 7.27 - 7.22 (m, 5H), 4.87 - 4.86 (m, 1H), 4.79 - 4.78 (m, 1H), 4.59 (s, 2H), 3.94 (s, 2H); ¹³C{¹H} NMR (101 MHz, Chloroform-*d*): δ 166.3, 152.5, 139.5, 136.3, 135.2, 129.0, 128.5, 128.0, 127.6, 127.4, 125.2, 122.2, 115.5, 54.2, 51.6, 19.9; MS (ESI) *m/z* (%) 359: [M+H]⁺ (100); HRMS (ESI) *m/z*: [M+H]⁺ calcd. for C₂₁H₁₉N₂O₂S₂, 359.0882; found, 359.0880.

N-benzyl-*N*-(prop-2-yn-1-yl)benzo[*d*]thiazole-2-sulfonamide (4-6ad).

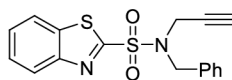

The crude product was purified using flash column chromatography (SiO₂; EtOAc/hexane = 1:4) and obtained as a colorless oil. FM alkylation: starting from 0.030 g (0.09 mmol) of 4-6a, yielded 0.031 g (94%); Base-promoted alkylation: starting from 0.030 g (0.09 mmol) of 4-6a, carried out at RT, yielded 0.024 g (72%). ¹H NMR (400 MHz, Chloroform-*d*): δ 8.23 (ddd, *J* = 8.2, 1.3, 0.6 Hz, 2H), 8.00 (ddd, *J* = 7.9, 1.4, 0.6 Hz, 2H), 7.67 - 7.60 (m, 1H), 7.60 - 7.54 (m, 1H), 7.42 - 7.32 (m, 5H), 4.74 (s, 2H), 4.06 (s, 2H), 1.87 - 1.86 (m, 1H); ¹³C{¹H} NMR (101 MHz, Chloroform-*d*): δ 164.8, 152.8, 136.5, 134.4, 129.0, 128.9, 128.5, 127.6, 127.5, 125.4, 122.2, 75.7, 74.3, 51.1, 36.4; MS (ESI) *m/z* (%) 343: [M+H]⁺ (100); HRMS (ESI) *m/z*: [M+H]⁺ calcd. for C₁₈H₁₆N₂O₂S₂, 343.0569; found, 343.0571.

(*S*)-*N*-benzyl-*N*-(octan-2-yl)benzo[*d*]thiazole-2-sulfonamide (4-6ae).

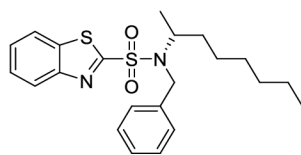

The crude product was purified using flash column chromatography (SiO₂; EtOAc/hexane = 1:8) and obtained as a colorless oil. FM alkylation: starting from 0.060 g (0.18 mmol) of 4-6a and (*R*)-octan-2-ol (0.057 mL, 0.36 mmol, *e.r.* = >99:1), yielded 0.051 g (62%), *e.r.* = >98:2; Base-promoted alkylation: starting from 0.060 g (0.18 mmol) of 4-6a and (±)-2-bromooctane (0.063 mL, 0.36 mmol), carried out at 50 °C, yielded 0.068 g (91%), *e.r.* = 51:49. $[\alpha]_{\text{D}}^{22} = -183^{\circ}$ (*c* 0.3, CH₂Cl₂); ¹H NMR (400 MHz, Chloroform-*d*): δ 8.18 – 8.16 (m, 1H), 7.96 (ddd, *J* = 7.9, 1.3, 0.6 Hz, 1H), 7.60 (ddd, *J* = 8.2, 7.3, 1.4 Hz, 1H), 7.54 (ddd, *J* = 8.4, 7.3, 1.3 Hz, 1H), 7.46 – 7.45 (m, 2H), 7.33 – 7.24 (m, 3H), 4.64 (d, *J* = 15.9 Hz, 1H), 4.51 (d, *J* = 15.9 Hz, 1H), 4.12 (hept, *J* = 6.8 Hz, 1H), 1.39 – 1.30 (m, 1H), 1.26 – 1.18 (m, 1H), 1.12 – 1.05 (m, 4H), 1.03 (d, *J* = 6.8 Hz, 3H), 1.02 – 0.93 (m, 4H), 0.76 (t, *J* = 7.2 Hz, 3H); ¹³C{¹H} NMR (101 MHz, Chloroform-*d*): δ 166.9, 152.7, 137.8, 136.5, 128.6, 128.5, 127.8, 127.5, 127.4, 125.2, 122.2, 56.2, 48.3, 35.6, 31.7, 29.0, 26.5, 22.6, 19.6, 14.2; MS (ESI) *m/z* (%) 417: [M+H]⁺ (100); HRMS (ESI) *m/z*: [M+H]⁺ calcd. for C₁₉H₂₁N₂O₄S₂, 417.1665; found, 417.1667; HPLC (Chiralpak IA3, CO₂/MeOH = 93/7, flow rate = 2.2 mL/min, I = 272 nm) tR = 4.21 min (minor), 4.51 min (major).

Ethyl *N*-(benzo[*d*]thiazol-2-ylsulfonyl)-*N*-benzylalaninate (4-6af).

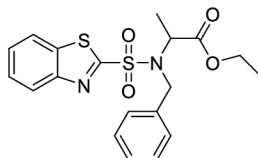

The crude product was purified using flash column chromatography (SiO₂; EtOAc/hexane = 1:4) and obtained as a slightly yellow oil. FM alkylation: starting from 0.054 g (0.17 mmol) of 4-6a, yielded 0.066 g (92%). $[\alpha]_{\text{D}}^{23} = -440^{\circ}$ (*c* 0.25, CH₂Cl₂); ¹H NMR (400 MHz, Chloroform-*d*): δ 8.19 – 8.17 (m, 1H), 7.99 – 7.96 (m, 1H), 7.61 (ddd, *J* = 8.3, 7.2, 1.4 Hz, 1H), 7.56 (ddd, *J* = 8.5, 7.2, 1.4 Hz, 1H), 7.44 – 7.42 (m, 2H), 7.34 – 7.24 (m, 3H), 4.93 (d, *J* = 16.4

Hz, 1H), 4.86 (q, $J = 7.3$ Hz, 1H), 4.54 (d, $J = 16.4$ Hz, 1H), 3.70 – 3.88 (m, 2H), 1.34 (d, $J = 7.4$ Hz, 1H), 0.96 (t, $J = 7.1$ Hz, 1H); $^{13}\text{C}\{^1\text{H}\}$ NMR (101 MHz, Chloroform-*d*): δ 170.7, 165.6, 152.7, 137.0, 136.5, 128.6, 128.2, 127.9, 127.7, 127.5, 125.2, 122.2, 61.6, 56.4, 50.3, 16.9, 13.8; MS (ESI) m/z (%) 405: $[\text{M}+\text{H}]^+$ (100); HRMS (ESI) m/z : $[\text{M}+\text{H}]^+$ calcd. for $\text{C}_{19}\text{H}_{21}\text{N}_2\text{O}_4\text{S}_2$, 405.0937; found, 405.0938.

(5*R*,5*aR*,8*aS*,9*S*)-9-(benzo[*d*]thiazol-2-yl(benzyl)amino)-5-(3,4,5-trimethoxyphenyl)-5,8,8*a*,9-tetrahydrofuro[3',4':6,7]naphtho[2,3-*d*][1,3]dioxol-6(5*aH*)-one (4-6*ag*).

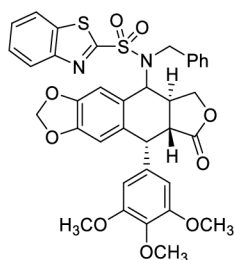

The crude product was purified using flash column chromatography (SiO_2 ; EtOAc/hexane = 1:8) and obtained as a colorless solid. FM alkylation: starting from 0.096 g (0.32 mmol) of 4-6*a*, yielded 0.067 g (30%, *d.r.* = >20:1) as a white solid. mp = 139-141 °C; $[\alpha]_{\text{D}}^{21} = -64.6^\circ$ (*c* 3.51, CH_2Cl_2); ^1H NMR (500 MHz, Chloroform-*d*): δ 8.35 – 8.33 (m, 1H), 8.09 – 8.06 (m, 1H), 7.75 – 7.65 (m, 2H), 7.35 – 7.33 (m, 3H), 7.05 – 7.03 (m, 2H), 6.78 (s, 1H), 6.50 (s, 1H), 6.11 (s, 2H), 5.98 – 5.97 (m, 2H), 5.78 (d, $J = 5.1$ Hz, 1H), 4.87 (d, $J = 15.5$ Hz, 1H), 4.47 (dd, $J = 9.2, 7.5$ Hz, 1H), 4.26 (dd, $J = 11.0, 9.2$ Hz, 1H), 4.06 (d, $J = 5.5$ Hz, 1H), 3.77 (s, 3H), 3.71 (s, 3H), 3.60 (d, $J = 15.4$ Hz, 1H), 2.82 (dddd, $J = 14.7, 10.9, 7.6, 5.0$ Hz, 1H), 1.51 (dd, $J = 14.7, 5.5$ Hz, 1H); $^{13}\text{C}\{^1\text{H}\}$ NMR (126 MHz, Chloroform-*d*): δ 174.1, 165.5, 152.7, 152.6, 149.1, 147.7, 137.3, 137.2, 136.6, 134.8, 134.8, 129.4, 129.3, 129.2, 128.3, 128.2, 125.3, 124.2, 122.5, 110.7, 109.8, 108.2, 101.9, 69.8, 60.9, 58.9, 56.4, 49.5, 43.7, 40.6, 37.6; MS (ESI) m/z (%) 701: $[\text{M}+\text{H}]^+$ (100); HRMS (ESI) m/z : $[\text{M}+\text{H}]^+$ calcd. for $\text{C}_{36}\text{H}_{33}\text{N}_2\text{O}_9\text{S}_2$, 701.1622; found, 701.1625.

N-allyl-*N*-(prop-2-yn-1-yl)benzo[*d*]thiazole-2-sulfonamide (4-6*bd*).

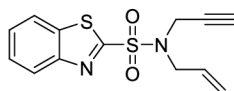

The crude product was purified using flash column chromatography (SiO₂; EtOAc/hexane = 1:3) and obtained as a colorless oil. FM alkylation: starting from 0.025 g (0.098 mmol) of 4-6b, yielded 0.022 g (77%); Base-promoted alkylation: starting from 0.023 g (0.09 mmol) of 4-6b, carried out at RT, yielded 0.024 g (86%). ¹H NMR (400 MHz, Chloroform-*d*): δ 8.20 (ddd, J = 8.2, 1.4, 0.7 Hz, 1H), 7.98 (ddd, J = 7.9, 1.5, 0.7 Hz, 1H), 7.61 (ddd, J = 8.2, 7.2, 1.4 Hz, 1H), 7.56 (ddd, J = 7.9, 7.2, 1.4 Hz, 1H), 5.78 (ddt, J = 17.1, 10.0, 6.5 Hz, 1H), 5.36 (dq, J = 17.1, 1.4 Hz, 1H), 5.28 (dq, J = 10.1, 1.2 Hz, 1H), 4.22 (d, J = 2.5 Hz, 2H), 4.18 (d, J = 6.5, 2H), 1.90 (t, J = 2.5 Hz, 1H); ¹³C{¹H} NMR (101 MHz, Chloroform-*d*): δ 164.9, 152.7, 136.5, 131.4, 127.6, 127.4, 125.3, 122.2, 120.7, 76.0, 73.9, 50.2, 36.6; MS (ESI) *m/z* (%) 293: [M+H]⁺ (100); HRMS (ESI) *m/z*: [M+H]⁺ calcd. for C₁₃H₁₃N₂O₂S₂, 293.0413; found, 293.0416.

N-butyl-*N*-isopropylbenzo[*d*]thiazole-2-sulfonamide (4-6ca).

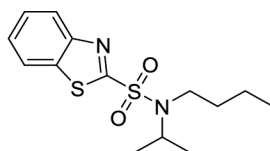

The crude product was purified using flash column chromatography (SiO₂; EtOAc/hexane = 2:5) and obtained as a colorless oil. FM alkylation: starting from 0.045 g (0.17 mmol) of 4-6c, yielded 0.049 g (88%); Base-promoted alkylation: starting from 0.024 g (0.09 mmol) of 4-6c, carried out at 50 °C, yielded 0.028 g (94%). ¹H NMR (400 MHz, Chloroform-*d*): δ 8.16 (ddd, J = 8.4, 1.3, 0.6 Hz, 1H), 7.96 (ddd, J = 7.8, 1.4, 0.6 Hz, 1H), 7.61 - 7.55 (m, 1H), 7.53 (ddd, J = 8.0, 7.3, 1.4 Hz, 3H), 4.35 (hept, 1H), 3.31 - 3.27 (m, 2H), 1.76 - 1.68 (m, 2H), 1.35 (sext, 2H), 1.17 (d, 6H), 0.94 (t, 3H); ¹³C{¹H} NMR (101 MHz, Chloroform-*d*): δ 167.00, 152.7, 136.4, 127.4, 127.3, 125.2, 122.1, 51.1, 44.0, 34.0, 21.5, 20.3, 13.8; MS (ESI) *m/z* (%) 313: [M+H]⁺ (100); HRMS (ESI) *m/z*: [M+H]⁺ calcd. for C₁₄H₂₁N₂O₂S₂, 313.1039; found, 313.1041.

N-butyl-*N*-(oxiran-2-ylmethyl)benzo[*d*]thiazole-2-sulfonamide (4-6cb).

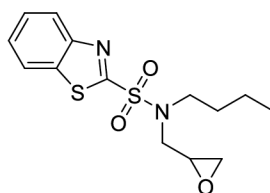

The crude product was purified using flash column chromatography (SiO₂; EtOAc/hexane = 1:35) and obtained as a colorless oil. FM alkylation: starting from 0.048 g (0.18 mmol) of 4-6c, yielded 0.043 g (74%). ¹H NMR (400 MHz, Chloroform-*d*): δ 8.16 (ddd, *J* = 8.5, 1.3, 0.6 Hz, 1H), 7.98 (ddd, *J* = 8.0, 1.5, 0.8 Hz, 1H), 7.63 – 7.59 (m, 1H), 7.58 – 7.53 (m, 1H), 4.00 (dd, *J* = 15.1, 3.0 Hz, 1H), 3.56 – 3.45 (m, 1H), 3.34 – 3.36 (m, 1H), 3.24 – 3.22 (m, 1H), 3.16 (dd, *J* = 15.0, 6.6 Hz, 1H), 2.81 (t, *J* = 4.3 Hz, 1H), 2.59 (ddd, *J* = 4.6, 2.5, 1.0 Hz, 1H), 1.71 – 1.61 (m, 2H), 1.41 – 1.29 (m, 2H), 0.92 (t, *J* = 7.4 Hz, 3H); ¹³C{¹H} NMR (101 MHz, Chloroform-*d*): δ 165.7, 152.6, 136.3, 127.6, 127.5, 125.2, 122.2, 51.8, 50.9, 50.0, 45.2, 30.6, 19.8, 13.7; MS (ESI) *m/z* (%) 327: [M+H]⁺ (100); HRMS (ESI) *m/z*: [M+H]⁺ calcd. for C₁₄H₁₉N₂O₃S₂, 327.0832; found, 327.0838.

Methyl N-(benzo[d]thiazol-2-ylsulfonyl)-N-butyl-L-alaninate (4-6cc).

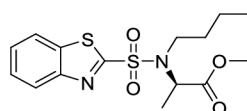

The crude product was purified using flash column chromatography (SiO₂; EtOAc/hexane = 1:3) and obtained as a colorless solid. FM alkylation: starting from 0.048 g (0.17 mmol) of 4-6c and methyl (*R*)-2-hydroxypropanoate (0.032 mL, 0.34 mmol, *e.r.* = >99:1), yielded 0.053 g (84%, *e.r.* = >98:1). mp = 53 – 55 °C; [α]_D²³ = –101° (*c* 0.25, CH₂Cl₂); ¹H NMR (400 MHz, Chloroform-*d*): δ 8.17 - 8.15 (m, 1H), 7.98 - 7.95 (m, 1H), 7.61 - 7.57 (m, 1H), 7.56 - 7.52 (m, 1H), 4.85 (q, *J* = 7.3 Hz, 2H), 3.57 (ddd, *J* = 15.6, 10.9, 5.2 Hz, 1H), 3.45 (s, 3H), 3.22 (ddd, *J* = 15.2, 10.9, 5.5 Hz, 1H), 1.84 – 1.73 (m, 1H), 1.68 – 1.58 (m, 1H), 1.51 (d, *J* = 7.3 Hz, 3H), 1.40 – 1.27 (m, 2H), 0.93 (t, *J* = 7.4 Hz, 2H); ¹³C{¹H} NMR (101 MHz, Chloroform-*d*): δ 171.6, 165.6, 152.6, 136.4, 127.6, 127.4, 125.2, 122.2, 56.2, 52.5, 46.9, 33.3, 20.2, 16.7, 13.8; MS (ESI) *m/z* (%) 358: [M+H]⁺ (100); HRMS (ESI) *m/z*: [M+H]⁺ calcd. for C₁₅H₂₁N₂O₄S₂, 357.0937; found, 357.0936; HPLC (Chiralpak IE3, CO₂/MeOH = 95/5, flow rate = 2.2 mL/min, I = 272 nm) tR = 5.50 min (minor), 5.89 min (major).

Methyl *N*-(benzo[*d*]thiazol-2-ylsulfonyl)-*N*-((*R*)-1-methoxy-1-oxopropan-2-yl)-*L*-alaninate (meso-4-6da).

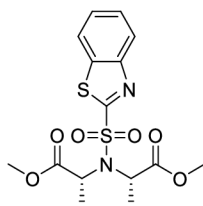

The crude product was purified using flash column chromatography (SiO₂; acetone/petroleum ether = 1:2) and obtained as a colorless oil. FM alkylation: starting from 0.023 g (0.08 mmol) of 4-6d and methyl (*R*)-2-hydroxypropanoate (0.016 mL, 0.16 mmol, *e.r.* = >99:1), yielded 0.010 g (33%, *d.r.* = >20:1). [α]_D²³ = 0° (*c* 0.1, CH₂Cl₂); ¹H NMR (400 MHz, Chloroform-*d*): δ 8.13 (ddd, *J* = 8.2, 1.4, 0.6 Hz, 1H), 7.97 (ddd, *J* = 7.8, 1.5, 0.6 Hz, 1H), 7.62 – 7.58 (m, 1H), 7.57 - 7.53 (m, 1H), 4.82 (q, *J* = 7.3 Hz, 1H), 3.67 (s, 6H), 1.56 (d, *J* = 7.3 Hz, 6H); ¹³C{¹H} NMR (101 MHz, Chloroform-*d*): δ 171.4, 167.2, 152.4, 136.4, 127.7, 127.5, 125.1, 122.3, 55.3, 52.7, 17.0; MS (ESI) *m/z* (%) 387: [M+H]⁺ (100); HRMS (ESI) *m/z*: [M+H]⁺ calcd. for C₁₅H₁₉N₂O₄S₂, 387.0679; found, 387.0684.

Intramolecular cyclization of aminoalcohol based on N-BT-sulfonylation/intramolecular Fukuyama-Mitsunobu alkylation: 2-(azepan-1-ylsulfonyl)benzo[*d*]thiazole (4-51).

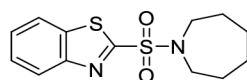

Sulfinic salt (0.200 g, 0.9 mmol, 1.0 equiv) was added to a mixture of THF (8 mL) and H₂O (2 mL) at RT and the resulting mixture was stirred for 5 min. 6-aminohexan-1-ol (0.107 g, 1 mmol, 1.1 equiv) followed by NBS (0.318 g, 1.8 mmol, 2.0 equiv) were added. After 10 min at RT, the whole mixture was diluted with CH₂Cl₂ (10 mL) and H₂O (10 mL) and the resulting layers were separated. Aqueous layer was extracted with CH₂Cl₂ (3 x 15 mL) and the combined organic layers were washed with brine (10 mL), dried over MgSO₄, filtered, and the solvents were removed under reduced pressure. The crude product was placed into a microwave reaction vessel and dissolved in THF (8 mL). DIAD (0.264 mL, 1.35 mmol, 1.5 equiv) and PPh₃ (0.262 g, 1.35 mmol, 1.5 mmol) were added and the reaction mixture was heated in a microwave reactor for 10 min at 50 °C (100 W). Reaction mixture was transferred to a flask and the solvents were removed under reduced pressure. The resulting crude product was purified by flash

column chromatography (SiO₂; EtOAc/hexane = 3:8) to yield the desired cyclized sulfonamide 4-51 (0.139 g, 59 % over two steps) in the form of colorless oil. ¹H NMR (400 MHz, Chloroform-*d*): δ 8.17 (ddd, *J* = 8.2, 1.2, 0.6 Hz, 2H), 7.97 (ddd, *J* = 7.8, 1.3, 0.6 Hz, 2H), 7.62 – 7.58 (m, 1H), 7.56 - 7.52 (m, 1H), 3.55 – 3.52 (m, 4H), 1.83 – 1.76 (m, 4H), 1.64 – 1.61 (m, 4H); ¹³C{¹H} NMR (101 MHz, Chloroform-*d*): δ 165.6, 152.7, 136.3, 127.4, 127.3, 125.2, 122.2, 49.1, 29.2, 27.0; MS (ESI) *m/z* (%) 297: [M+H]⁺ (100); HRMS (ESI) *m/z*: [M+H]⁺ calcd. for C₁₃H₁₇N₂O₂S₂, 297.0726; found, 297.0728.

N-benzylbenzo[*d*]thiazol-2-amine (4-62) synthesis:

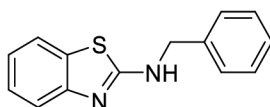

A solution of sulfonamide 4-6 (0.127 g, 0.42 mmol, 1.0 equiv) and Cs₂CO₃ (0.274 g, 0.84 mmol, 2.0 equiv) were added to 1,4-dioxane (5 mL) and the resulting mixture was degassed using freeze-pump-thaw technique (three times). (PPh₃)₂PdCl₂ (0.059 g, 0.084 mmol, 0.2 equiv) was added and the resulting mixture was heated at 100 °C (external temperature, oil bath) for 24h. The resulting mixture was cooled to RT, diluted with CH₂Cl₂ (25 mL), and filtered through a pad of Celite®. Filter cake was washed with additional CH₂Cl₂ (3 x 25 mL) and the combined filtrates were evaporated under reduced pressure. Residue was purified by flash column chromatography (SiO₂; EtOAc/petroleum ether = 1:5->1:2->1:1) to yield the desired product 4-62 (0.077 g, 76%) as a colorless oil. mp = 163-165 °C (164-168 °C lit⁵⁸); ¹H NMR (500 MHz, Chloroform-*d*): δ 7.58 (d, *J* = 7.9 Hz, 1H), 7.33 – 7.20 (m, 7H), 7.06 (t, *J* = 7.8 Hz, 1H), 6.84 (broad s, 1H), 4.64 (s, 2H); ¹³C{¹H} NMR (126 MHz, Chloroform-*d*): δ 165.9, 153.3, 136.6, 129.3, 128.8, 128.0, 127.9, 123.9, 121.9, 121.1, 119.8, 50.5; MS (ESI) *m/z* (%) 241: [M+H]⁺ (100); HRMS (ESI) *m/z*: [M+H]⁺ calcd. for C₁₄H₁₃N₂S, 241.0794; found, 241.0796.

General procedure for Chan-Lam coupling

Sulfonamide 3 (0.1 mmol, 1 equiv) was dissolved in dry DCE (2.0 mL, 0.05 M), and boronic acid (0.2 mmol, 2 equiv), TMEDA (0.06 mL, 0.4 mmol, 4 equiv) and [Cu(CH₃CN)₄]PF₆ (0.015 g, 0.04 mmol, 0.4 equiv) were added. The resulting mixture was placed under an atmosphere of O₂ (1 atm) and stirred for 4h at RT. The whole mixture was filtered over a pad of Celite®,

and the filter cake was washed with CH₂Cl₂ (3 x 25 mL). Resulting filtrates were combined and the solvents were removed under reduced pressure.

N-benzyl-*N*-phenylbenzo[*d*]thiazole-2-sulfonamide (4-6ah).

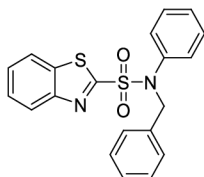

Prepared starting from sulfonamide 4-6a (0.030 g, 0.09 mmol) and phenylboronic acid (0.022 g, 0.18 mmol). The crude product was purified using flash column chromatography (SiO₂; EtOAc/hexane = 1:3) to yield 0.025 g (67%) of 4-6ah obtained as a colorless oil. ¹H NMR (400 MHz, Chloroform-*d*): δ 8.31 (ddd, *J* = 8.2, 1.3, 0.7 Hz, 1H), 7.99 (ddd, *J* = 8.1, 1.3, 0.7 Hz, 1H), 7.68 (ddd, *J* = 8.4, 7.2, 1.3 Hz, 1H), 7.61 (ddd, *J* = 8.3, 7.2, 1.2 Hz, 1H), 7.33 – 7.23 (m, 8H), 7.17 – 7.12 (m, 2H), 5.13 (s, 1H); ¹³C{¹H} NMR (101 MHz, Chloroform-*d*): δ 165.7, 152.6, 138.2, 136.7, 135.6, 129.3, 128.9, 128.7, 128.6, 128.1, 127.7, 127.5, 125.4, 122.3, 56.9; MS (ESI) *m/z* (%) 381: [M+H]⁺ (100); HRMS (ESI) *m/z*: [M+H]⁺ calcd. for C₂₀H₁₇N₂O₂S₂, 381.0726; found, 381.0728

N-benzyl-*N*-(3-methoxyphenyl)benzo[*d*]thiazole-2-sulfonamide (4-6ai).

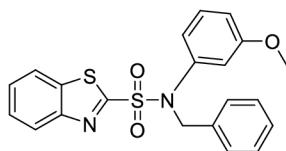

Prepared starting from sulfonamide 4-6a (0.030 g, 0.09 mmol) and 3-methoxyphenylboronic acid (0.027 g, 0.18 mmol). The crude product was purified using flash column chromatography (SiO₂; EtOAc/hexane = 1:5->1:3) and the collected fractions containing the product were concentrated under reduced pressure. The resulting crude product was purified by semiprep HPLC (MeCN/buffer, gradient 9:1 to 3:2 over 6 min) to yield 0.0155 g (42%) of 6d obtained as a colorless oil. ¹H NMR (400 MHz, Chloroform-*d*): δ 8.28-8.25 (m, 1H), 7.98-7.95 (m, 1H), 7.67-7.63 (m, 1H), 7.60 - 7.55 (m, 1H), 7.30 – 7.23 (m, 5H), 7.11 (ddd, *J* = 8.3, 7.9, 0.8 Hz, 1H), 6.77 (ddd, *J* = 8.4, 2.3, 1.1 Hz, 1H), 6.69 – 6.66 (m, 2H), 5.07 (s, 2H), 3.62 (s, 3H); ¹³C{¹H} NMR (101 MHz, Chloroform-*d*): δ 165.8, 160.1, 152.6, 139.3, 136.7, 135.7, 129.8, 128.9, 128.6, 128.1, 127.7, 127.5, 125.4, 122.3, 121.3, 115.2, 114.7, 56.9, 55.4; MS (ESI) *m/z* (%) 411: [M+H]⁺ (100); HRMS (ESI) *m/z*: [M+H]⁺ calcd. for C₂₁H₁₉ N₂O₃S₂, 411.0832; found, 411.0833.

N-benzyl-*N*-(4-chlorophenyl)benzo[*d*]thiazole-2-sulfonamide (4-6aj).

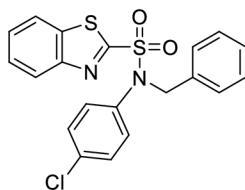

Prepared starting from sulfonamide 4-6a (0.030 g, 0.09 mmol) and 4-chlorophenylboronic acid (0.028 g, 0.18 mmol). The crude product was purified using flash column chromatography (SiO₂; EtOAc/petroleum ether = 1:6) to yield 0.026 g (65%) of 6e obtained as a colorless oil. ¹H NMR (400 MHz, Chloroform-*d*): δ 8.27 (d, *J* = 8.1 Hz, 1H), 7.97 (d, *J* = 8.2 Hz, 1H), 7.66 (ddd, *J* = 8.3, 7.3, 1.3 Hz, 1H), 7.59 (ddd, *J* = 8.2, 7.3, 1.2 Hz, 1H), 7.30 – 7.19 (m, 7H), 7.15 (t, *J* = 7.9 Hz, 1H), 7.03 (ddd, *J* = 7.9, 2.0, 1.2 Hz, 1H), 5.05 (s, 2H); ¹³C{¹H} NMR (101 MHz, Chloroform-*d*): δ 165.2, 152.6, 139.4, 136.6, 135.1, 134.7, 130.2, 129.6, 129.0, 128.9, 128.7, 128.3, 127.9, 127.7, 127.6, 125.5, 122.3, 56.7; MS (ESI) *m/z* (%) 415: [M+H]⁺ (100); HRMS (ESI) *m/z*: [M+H]⁺ calcd. for C₂₀H₁₆ClN₂O₂S₂, 415.0336; found, 415.0341.

N-benzyl-*N*-(4-bromophenyl)benzo[*d*]thiazole-2-sulfonamide (4-6ak).

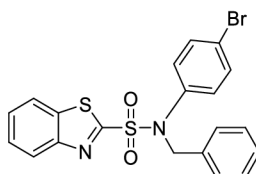

Prepared starting from sulfonamide 4-6a (0.030 g, 0.09 mmol) and 4-bromophenylboronic acid (0.036 g, 0.18 mmol). The crude product was purified using flash column chromatography (SiO₂; EtOAc/hexan = 1:3) and the collected fractions containing the product were concentrated under reduced pressure. The resulting crude product was purified by semiprep HPLC (MeCN/buffer, gradient 9:1 to 3:2 over 6 min) to yield 0.0107 g (26%) of 6g obtained as a colorless oil. ¹H NMR (400 MHz, Chloroform-*d*): δ 8.26 (ddd, *J* = 8.3, 1.2, 0.7 Hz, 1H), 7.97 (ddd, *J* = 8.0, 1.3, 0.7 Hz, 1H), 7.66 (ddd, *J* = 8.3, 7.2, 1.3 Hz, 1H), 7.59 (ddd, *J* = 8.4, 7.2, 1.3 Hz, 1H), 7.36 – 7.33 (m, 2H), 7.27 – 7.25 (m, 9H), 7.02 – 6.98 (m, 2H), 5.05 (s, 2H); ¹³C{¹H} NMR (101 MHz, Chloroform-*d*): δ 165.3, 152.6, 137.2, 135.2, 132.6, 130.9, 128.9, 128.8, 128.3, 127.9, 127.7, 125.5, 122.8, 122.3, 56.8; MS (ESI) *m/z* (%) 459: [M+H]⁺ (100); HRMS (ESI) *m/z*: [M+H]⁺ calcd. for C₂₀H₁₆BrN₂O₂S₂, 458.9831; found 458.9833.

N-([1,1'-biphenyl]-4-yl)-*N*-benzylbenzo[*d*]thiazole-2-sulfonamide (4-6al).

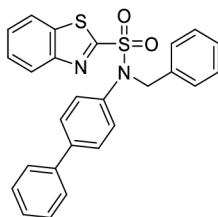

Prepared starting from sulfonamide 4-6a (0.030 g, 0.09 mmol) and 1,1'-biphenyl]-4-ylboronic acid (0.036 g, 0.18 mmol). The crude product was purified using flash column chromatography (SiO₂; EtOAc/petroleum ether = 1:3) to yield 0.026 g (65%) of 4-6al obtained as a colorless oil. ¹H NMR (400 MHz, Chloroform-*d*): δ 8.27 (d, *J* = 8.2 Hz, 1H), 7.95 (d, *J* = 8.6 Hz, 1H), 7.66 – 7.62 (m, 1H), 7.59 – 7.55 (m, 1H), 7.49 – 7.35 (m, 6H), 7.32 – 7.24 (m, 6H), 7.17 – 7.15 (m, 2H), 5.12 (s, 2H); ¹³C{¹H} NMR (101 MHz, Chloroform-*d*): δ 165.6, 152.6, 141.4, 139.9, 137.2, 136.6, 135.6, 129.5, 128.9, 128.6, 128.0, 127.9, 127.8, 127.6, 127.5, 127.1, 125.4, 122.2, 56.8; MS (ESI) *m/z* (%) 457: [M+H]⁺ (100); HRMS (ESI) *m/z*: [M+H]⁺ calcd. for C₂₆H₂₁N₂O₂S₂, 457.1039; found 457.1040.

N-allyl-*N*-phenylbenzo[*d*]thiazole-2-sulfonamide (4-6bh).

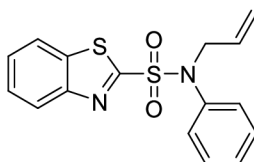

Prepared starting from sulfonamide 3b (0.024 g, 0.09 mmol) and phenylboronic acid (0.022 g, 0.18 mmol). The crude product was purified using flash column chromatography (SiO₂; EtOAc/hexane = 1:3) to yield 0.020 g (63%) of 4-6bh obtained as a colorless oil. ¹H NMR (400 MHz, Chloroform-*d*): δ 8.25 – 8.23 (m, 1H), 7.95 – 7.93 (m, 1H), 7.63 (ddd, *J* = 8.4, 7.2, 1.3 Hz, 1H), 7.56 (ddd, *J* = 8.3, 7.1, 1.2 Hz, 1H), 7.34 – 7.30 (m, 3H), 7.23 – 7.21 (m, 2H), 5.87 (ddt, *J* = 16.6, 10.2, 6.4 Hz, 1H), 5.15 (dd, *J* = 17.0, 1.5 Hz, 1H), 5.11 (dd, *J* = 9.7, 1.4 Hz, 1H), 4.54 (dt, *J* = 6.5, 1.3 Hz, 2H); ¹³C{¹H} NMR (101 MHz, Chloroform-*d*): δ 165.6, 152.6, 138.3, 136.7, 132.6, 129.4, 129.2, 128.7, 127.7, 127.5, 125.4, 122.3, 119.6, 55.6; MS (ESI) *m/z* (%) 331: [M+H]⁺ (100); HRMS (ESI) *m/z*: [M+H]⁺ calcd. for C₁₆H₁₅N₂O₂S₂, 331.0569; found, 331.0573.

N-([1,1'-biphenyl]-4-yl)-N-allylbenzo[d]thiazole-2-sulfonamide (4-6bl).

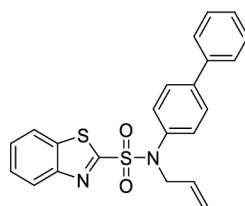

Prepared starting from sulfonamide 4-6b (0.030 g, 0.09 mmol) and 1,1'-biphenyl]-4-ylboronic acid (0.036 g, 0.18 mmol). The crude product was purified using flash column chromatography (SiO₂; EtOAc/petroleum ether = 1:3) and the collected fractions containing the product were concentrated under reduced pressure. The resulting crude product was purified by semiprep HPLC (MeCN/buffer, gradient 9:1 to 3:2 over 6 min) to yield 0.026 g (72%) of 4-6bl obtained as a colorless oil.

¹H NMR (400 MHz, Chloroform-*d*): δ 8.26 (ddd, *J* = 8.3, 1.3, 0.7 Hz, 1H), 7.96 (ddd, *J* = 8.0, 1.3, 0.7 Hz, 1H), 7.65 (ddd, *J* = 8.3, 7.2, 1.3 Hz, 1H), 7.58 (ddd, *J* = 8.1, 7.2, 1.3 Hz, 1H), 7.52 (ddd, *J* = 7.8, 1.8, 1.1 Hz, 1H), 7.43 (td, *J* = 2.0, 0.4 Hz, 2H), 7.41 – 7.30 (m, 6H), 7.20 (ddd, *J* = 7.9, 2.1, 1.1 Hz, 1H), 5.90 (ddt, *J* = 16.5, 10.2, 6.4 Hz, 1H), 5.17 (ddd, *J* = 16.9, 2.6, 1.3 Hz, 1H), 5.13 (ddd, *J* = 10.1, 2.3, 1.1 Hz, 1H), 4.56 (dt, *J* = 6.4, 1.3 Hz, 2H); ¹³C{¹H} NMR (101 MHz, Chloroform-*d*): δ 165.6, 152.7, 142.6, 140.0, 138.8, 136.7, 132.6, 129.7, 129.0, 128.0, 127.9, 127.9, 127.7, 127.6, 127.4, 127.2, 125.4, 122.3, 119.7, 55.7; MS (ESI) *m/z* (%) 407: [M+H]⁺ (100); HRMS (ESI) *m/z*: [M+H]⁺ calcd. for C₂₂H₁₉N₂O₂S₂, 407.0882; found, 407.0886.

N-butyl-N-phenylbenzo[d]thiazole-2-sulfonamide (4-6ch).

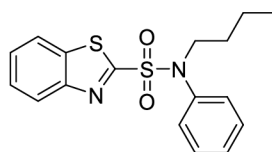

Prepared starting from sulfonamide 4-6c (0.062 g, 0.22 mmol) and phenylboronic acid (0.054 g, 0.44 mmol). The crude product was purified using flash column chromatography (SiO₂; EtOAc/hexane = 1:4) to yield 0.044 g (58%) of 4-6ch obtained as a colorless oil. ¹H NMR (400 MHz, Chloroform-*d*): δ 8.24 – 8.22 (m, 1H), 7.95 – 7.92 (m, 1H), 7.62 (ddd, *J* = 8.3, 7.2, 1.3 Hz, 1H), 7.55 (ddd, *J* = 8.3, 7.3, 1.3 Hz, 1H), 7.34 – 7.30 (m, 3H), 7.23 – 7.20 (m, 2H), 3.92 (t, *J* = 7.1 Hz, 2H), 1.53 – 1.47 (m, 2H), 1.43 – 1.34 (m, 2H), 0.89 (t, *J* = 7.3 Hz, 2H); ¹³C{¹H} NMR (101 MHz, Chloroform-*d*): δ 165.5, 152.7, 138.4, 136.6, 129.4, 129.2, 128.7, 127.6,

127.4, 125.4, 122.2, 52.5, 30.7, 19.7, 13.7; MS (ESI) m/z (%) 347: $[M+H]^+$ (100); HRMS (ESI) m/z : calcd. for $C_{17}H_{19}N_2O_2S_2$, 347.0882; found, 347.0885.

N-benzyl-*N*-(3-fluorophenyl)benzo[*d*]thiazole-2-sulfonamide (4-6fa).

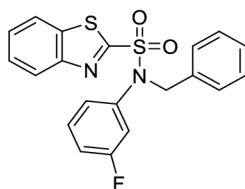

Prepared starting from sulfonamide 3a (0.030 g, 0.09 mmol) and 3-fluorophenylboronic acid (0.025 g, 0.18 mmol). The crude product was purified using flash column chromatography (SiO_2 ; EtOAc/petroleum ether = 1:3) to yield 0.017 g (45%) of 6f obtained as a colorless oil. 1H NMR (400 MHz, Chloroform-*d*): δ 8.27 (dd, $J = 9.2, 0.9$ Hz, 1H), 7.97 (dd, $J = 8.4, 1.5$ Hz, 1H), 7.66 (ddd, $J = 8.4, 7.2, 1.3$ Hz, 1H), 7.59 (ddd, $J = 8.3, 7.2, 1.2$ Hz, 1H), 7.28 – 7.23 (m, 5H), 7.19 (td, $J = 8.2, 6.3$ Hz, 1H), 6.97 - 6.90 (m, 3H), 5.07 (s, 2H); $^{13}C\{^1H\}$ NMR (101 MHz, Chloroform-*d*): δ 165.3, 162.66 (d, $J = 248.6$ Hz), 152.6, 139.6 (d, $J = 9.7$ Hz), 136.6, 135.2, 130.3 (d, $J = 9.0$ Hz), 128.9, 128.7, 128.3, 127.9, 127.7, 125.5, 125.0 (d, $J = 3.3$ Hz), 122.3, 116.7 (d, $J = 22.8$ Hz), 115.9 (d, $J = 20.8$ Hz), 56.8; $^{19}F\{^1H\}$ NMR (376 MHz, Chloroform-*d*): δ -110.8; MS (ESI) m/z (%) 399: $[M+H]^+$ (100); HRMS (ESI) m/z : $[M+H]^+$ calcd for $C_{21}H_{35}N_2O_4S_2Si$, 399.0632; found, 399.0635.

Benzo[*d*]thiazol-2-ylsulfonyl group cleavage:

Ethanthiolysis: *N,N*-dibenzylsulfonamide 6-4aa (0.050 g, 0.12 mmol) was dissolved in CH_3CN (1.2 mL) at RT, and EtSLi (0.024 g, 0.36 mmol, 3.0 equiv) was added. The resulting mixture was stirred at RT for 12h. Solvents were removed under reduced pressure and the resulting crude product was purified with flash column chromatography (SiO_2 ; EtOAc/hexane = 1:1) to yield compound 11 (0.022g, 95%) as a yellowish oil.

$NaBH_4$ reduction: *N,N*-dibenzylsulfonamide 6-4aa (0.129 g, 0.33 mmol) was dissolved in EtOH (2 mL) at RT, and $NaBH_4$ (0.049 g, 1.3 mmol, 4.0 equiv) was added. The resulting mixture was stirred at RT for 12h. The whole mixture was diluted with CH_2Cl_2 (10 mL) and H_2O (10 mL), and the layers were separated. Aqueous layer was extracted with CH_2Cl_2 (2 x 15 mL), and the organic layers were combined, washed with brine (10 mL), dried over Na_2SO_4 ,

filtered, and the solvents were removed under reduced pressure. The crude product was purified by flash column chromatography (SiO₂; EtOAc/hexane = 1:1) to give the desired compound 11 (0.063 g, 98%) as yellowish oil.

Dibenzylamine (4-78):

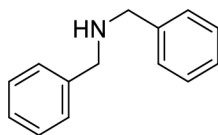

¹H NMR (400 MHz, Chloroform-*d*): δ 7.37 - 7.32 (10 H), 3.82 (4 H); ¹³C{¹H} NMR (101 MHz, Chloroform-*d*): δ 140.3, 128.6, 128.3, 127.1, 53.2; MS (ESI) *m/z* (%) 198: [M+H]⁺ (100); HRMS (ESI) *m/z*: [M+H]⁺ calcd. for C₁₄H₁₆N, 198.1277; found 198.1277.

Smiles rearrangement:

ethyl 2-(benzo[d]thiazol-2-yl)-2-(benzylamino)propanoate (4-73)

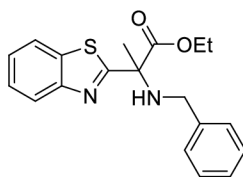

Sulfonamid (0.018 g, 0.048 mmol) was dissolved in THF (0.5 mL) and the mixture was cooled to -85 °C. Pre-cooled 1M KHDMS in THF (0.072 mL, 0.072 mmol) was added over period of 5 minutes. After 15 minutes after the addition, the reaction mixture was quenched with water and the resulting mixture was extracted into EtOAc (3 x 4.5 mL) and the organic layers were combined, dried over Na₂SO₄, filtered, and the solvents were removed under reduced pressure. The crude product was purified with flash column chromatography (SiO₂; EtOAc/hexane = 1:3) to yield compound 4-73 (0.012 g, 75%) as a yellowish oil. ¹H NMR (400 MHz, Chloroform-*d*): δ 8.01 - 8.05 (m, 1H), 7.89 (d, *J* = 7.6 Hz, 1H), 7.49 - 7.33 (m, 6H), 7.29 - 7.27 (m, 1H), 4.26 (q, *J* = 7.1 Hz, 2H), 3.84 3.77 (m, 2H), 1.96 (s, 3H), 2.12 - 1.92 (bs, 1H), 1.26 (t, *J* = 7.1 Hz, 3H). ¹³C{¹H} NMR (101 MHz, Chloroform-*d*): δ 172.12, 153.37, 135.60, 128.58, 128.42, 127.40, 126.00, 125.23, 123.46, 121.78, 66.45, 62.25, 48.12, 31.66, 23.40, 22.73, 14.18. MS (ESI) *m/z* (%) 341: [M+H]⁺ (100); HRMS (ESI) *m/z*: [M+H]⁺ calcd. for C₁₉H₂₁N₂O₂S₁, 341.1381; found, 341.1376; HPLC (Lux® 5 μ m, i-Amylose-1, Hex/IPA = 80/20, flow rate = 0.6 mL/min, I = 255 nm) tR = 8.80 min (minor), 11.88 min (major).

Preparation of (S)-2-(benzo[d]thiazole-2-sulfonamido)-N-((1R,2R)-2-(3-phenylthioureido)cyclohexyl)propanamide:

(benzo[d]thiazol-2-ylsulfonyl)-L-alanine (4-98):

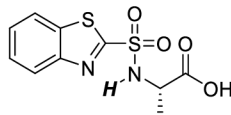

methyl (benzo[d]thiazol-2-ylsulfonyl)-L-alaninate (1 g, 3.3 mmol) was dissolved in THF (16 mL) at rt and a solution of LiOH (0.392 g, 16 mmol) in H₂O (16 mL) was added dropwise. The reaction mixture was stirred at rt for 2 hours. After the reaction completion, the reaction was acidified with 10% HCl to pH = 3. The resulting mixture was extracted into EtOAc (3 x 20 mL) and the organic layers were combined, dried over Na₂SO₄, filtered, and the solvents were removed under reduced pressure. The crude product was purified by flash column chromatography (SiO₂; EtOAc/hexane = 2.5:1) to give the desired compound (0.83 g, 88 %) as colorless oil. ¹H NMR (400 MHz, Chloroform-*d*): δ 8.11 - 8.09 (m, 1H), 7.97 - 7.95 (m, 1H), 7.60 - 7.53 (m, 2H), 6.04 (d, *J* = 7.3 Hz, 1H), 4.46 (p, *J* = 7.2 Hz, 1H); ¹³C NMR (101 MHz, Chloroform-*d*) δ 175.3, 166.2, 151.9, 136.2, 127.9, 127.7, 125.0, 122.3, 52.3, 19.8; MS (ESI) *m/z* (%) 285: [M-H]⁻ (100); HRMS (ESI) *m/z*: [M+H]⁺ calcd. for C₁₀H₁₁N₂O₄S₂, 281.0155; found 281.0151.

1-((1R,2R)-2-aminocyclohexyl)-3-phenylthiourea(4-99):

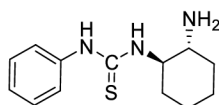

To a solution of (1R,2R)-cyclohexane-1,2-diamine (0.57 g, 5 mmol) in DCM (10 mL) was added a solution of phenyl isothiocyanate (0.658 mL, 5 mmol) in DCM (10 mL). The reaction mixture was stirred at RT for 3 hours. After the reaction completion (monitored by TLC), the solvent was removed *in vacuo* and the crude product was purified by flash column chromatography (SiO₂; Et₂O/MeOH = 1:1 -> 1:6) to give the desired compound (0.62 g, 51 %) as yellowish solid. The obtained ¹H NMR data matched with literature.¹⁹⁴ ¹H NMR (400 MHz, Chloroform-*d*): δ 8.30 (bs, 1H), 7.45 - 7.22 (4 H), 7.25 - 7.17 (m, 1H), 6.23 (d, *J* = 7.1 Hz, 1H), 4.05 (bs, 1H), 2.48 (bs, 1H), 2.16 - 2.13 (m, 1H), 1.94 - 1.88 (m, 1H), 1.78 - 1.61 (m, 3H), 1.37 - 1.01 (m, 5H).

(*S*)-2-(benzo[*d*]thiazole-2-sulfonamido)-*N*-((1*R*,2*R*)-2-(3-phenylthioureido)cyclohexyl)propenamide (4-146):

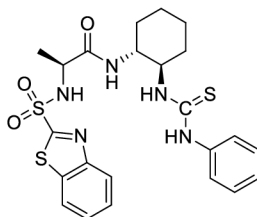

To a solution of carboxylic acid (0.04 g, 0.139 mmol) in DMF (0.7 mL) was added DIPEA (0.029 mL, 0.167 mmol) and the resulting mixture was cooled to 0 °C (ice water bath). Followed by an addition of HATU (0.063 g, 0.167 mmol) and after stirring for 15 mins at 0 °C, Amine (0.034 g, 0.139 mmol) was added. The reaction mixture was stirred for 2 hours at the same temperature and then let to warm to RT. After the reaction completion (monitored by TLC), the mixture was quenched by 10 % HCl. The resulting mixture was extracted into EtOAc (3 x 5 mL) and the organic layers were combined, dried over Na₂SO₄, filtered, and the solvents were removed under reduced pressure. The crude product was purified by flash column chromatography (SiO₂; EtOAc/hexane = 2.5:1.5) to give the desired compound (0.032 g, 45 %) as colorless oil. ¹H NMR (400 MHz, Chloroform-*d*): δ 8.12 (ddd, *J* = 8.2, 1.4, 0.6 Hz, 1H), 7.95 (ddd, *J* = 7.7, 1.5, 0.7 Hz, 1H), 7.62 (bs, 1H), 7.57 (ddd, *J* = 8.1, 7.2, 1.5 Hz, 1H), 7.55 - 7.51 (m, 1H), 7.36 - 7.43 (m, 2H), 7.27 - 7.33 (m, 1H), 7.10 (d, *J* = 7.7 Hz, 1H), 6.95 (d, *J* = 8.0 Hz, 1H), 6.19 (d, *J* = 7.6 Hz, 1H), 5.94 (d, *J* = 8.9 Hz, 1H), 4.35 - 4.46 (m, 1H), 4.26 (p, *J* = 7.0 Hz, 1H), 3.39 - 3.50 (m, 1H), 1.95 - 2.05 (m, 1H), 1.61 - 1.75 (m, 1H), 1.49 (d, *J* = 7.0 Hz, 3H), 1.25 - 1.35 (m, 1H), 0.99 - 1.18 (m, 3H), 0.76 - 0.90 (m, 1H). ¹³C NMR (101 MHz, Chloroform-*d*) δ 180.7, 171.0, 166.1, 152.4, 136.5, 135.3, 130.4, 127.8, 127.6, 127.3, 125.3, 125.2, 122.3, 57.7, 55.3, 53.5, 32.1, 31.9, 24.6, 24.3, 20.6. MS (ESI) *m/z* (%) 518: [M+H]⁺ (100); HRMS (ESI) *m/z*: [M+H]⁺ calcd. for C₂₃H₂₈N₅O₃S₃, 518.1349; found 518.1347.

Preparation of benzofuranes:

Methyl (E)-7-methoxy-5-(3-methoxy-3-oxoprop-1-en-1-yl)-2-[3-methoxy-4-(methoxymethoxy)phenyl]benzofuran-3-carboxylate (4-141):

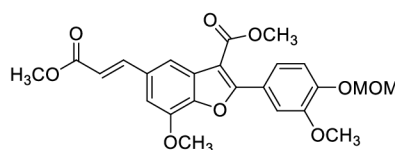

β -ketoester (0.236 g, 1 mmol) and phenol (0.229 g, 1.1 mol) were dissolved in dry DCE (2 mL) followed by the addition of NHPI (0.09 g, 0.05 mmol) and FeCl₃ (0.16 mmol, 0.1 mmol). To a resulting mixture was added dropwise a solution of DTBP (0.366 g, 2.5 mmol) in DCE (1 mL). The reaction mixture was stirred for 20 hours at 80 °C. After cooling, the reaction mixture was filtrated through pad of Celite® and washed with aq. Solution of Na₂CO₃ (10 mL). The filtrate was extracted into DCM (3 x 10 mL). Combined organic layers were dried over MgSO₄ and the solvent was removed *in vacuo* and the crude product was purified by flash column chromatography (SiO₂; Et₂O/EtOAc = 4:1 -> 2:1) to give the desired compound (0.164 g, 36 %). M.p: 168–169 °C, ¹H NMR (400 MHz, CDCl₃): d = 3.50 (s, 3H), 3.94 (s, 3 H), 3.96 (s, 3 H), 4.02 (s, 3 H), 4.04 (s, 3H), 5.06 (s, 2 H), 6.41 (d, J = 15.9 Hz, 1H), 6.95 (d, J = 8.4 Hz, 1H), 7.23 (d, J = 2.1 Hz, 1H), 7.44 (dd, J = 8.4, 1.6 Hz, 1H), 7.56 (d, J = 1.7 Hz, 1H), 7.76 (d, J = 15.8 Hz, 1H), 7.80 (s, 1 H) ppm; ¹³C NMR (100.1 MHz, CDCl₃): d = 51.2, 52.4, 54.2, 56.4, 58.9, 92.7, 110.0, 111.5, 111.6, 114.5, 115.6, 116.2, 121.2, 122.9, 128.1, 131.2, 143.3, 146.4, 146.6, 148.9, 149.9, 160.4, 167.5, 167.9; MS (ESI): m/z = 457 ([M+H]⁺; HRMS (ESI): m/z calcd. for C₂₄H₂₅O₉, 457.1493, found 457.1490.

ethyl 2-(4-methoxyphenyl)benzofuran-3-carboxylate (4-145)

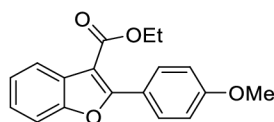

β -ketoester (1 g, 4.5 mmol) and phenol (0.460 g, 4.9 mmol) were dissolved in dry DCE (40 mL) followed by the addition of NHPI (0.036 g, 0.225 mmol) and FeCl₃ (0.072 g, 0.45 mmol). To a resulting mixture was added dropwise a solution of DTBP (1.64 g, 11.24 mmol) in DCE (5 mL). The reaction mixture was stirred for 20 hours at 80 °C. After cooling, the reaction mixture was filtrated through pad of Celite® and washed with aq. Solution of Na₂CO₃ (10 mL). The filtrate was extracted into DCM (3 x 10 mL). Combined organic layers were dried over MgSO₄ and the solvent was removed *in vacuo* and the crude product was purified by flash column chromatography (SiO₂; Et₂O/EtOAc = 4:1 -> 2:1) to give the desired compound (1.37 g, 95 %). ¹H NMR (400 MHz, Chloroform-d) δ (ppm): 8.07 – 8.02 (m, 3H), 7.54 – 7.48 (m, 1H), 7.36 – 7.30 (m, 2H), 7.05 – 6.98 (m, 2H), 4.42 (q, J = 7.1 Hz, 2H), 3.89 (s, 3H), 1.43 (t, J = 7.1 Hz, 3H). ¹³C NMR (101 MHz, Chloroform-d) δ (ppm) 164.4, 161.4, 161.2, 153.7, 131.3, 127.5, 125.0, 124.0, 122.7, 122.2, 113.7, 111.1, 107.9, 60.7, 55.5, 14.5. MS (ES⁺), m/z (%): 297 [M+H]⁺, 335 [M+K]⁺. HRMS (ESI⁺) calcd. for C₁₈H₁₇O₄: 297.1121, found 297.1124.

(cyclohex-1-en-1-yloxy)trimethylsilane (4-109)

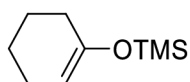

A solution of sodium iodide (9.4 g, 60 mmol) in MeCN (80 mL) was added to neat cyclohexanone (5.0 g, 50 mmol), Me₃SiCl (6.8 g, 60 mmol) and Et₃N (6.4 g, 60 mmol). The reaction mixture was stirred at rt for 18 hr. The reaction mixture was extracted into pentane (3 x 40 mL) and the combined pentane layers were dried over MgSO₄ and the solvent was removed *in vacuo*. The resulting crude product (6.6 g, 85 %) was used in the next reactions without further purification. The obtained ¹H NMR data matched with literature.¹⁹⁵ ¹H NMR (400 MHz, Chloroform-d) δ 5.08 – 5.05 (m, 1H), 2.18 – 2.14 (m, 2H), 2.11 – 2.05 (m, 2H), 1.66 – 1.61 (m, 2H), 1.54 – 1.49 (m, 2H), 0.28 (s, 9H).

(E)-N,1-diphenylmethanimine (4-112)

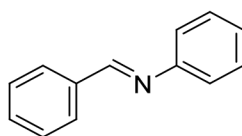

To benzaldehyde (1 mL, 9.8 mmol) was rapidly added aniline (0.89 mL, 9.8 mmol) and the mixture was stirred without solvent. After 1 hr, the reaction mixture was poured into cold (0°C) 95 % EtOH (1.5 mL). The yellowish solid crashed out of the solution and it was filtered out. The compound was used in the next reactions without further purification (1,543 g, 87 %). The obtained ¹H NMR data matched with literature.¹⁹⁶ ¹H NMR (400 MHz, Chloroform-d) δ 8.47 (s, 1H), 7.89 – 7.93 (m, 2H), 7.49 – 7.48 (m, 3H), 7.42 – 7.38 (m, 2H), 7.19 – 7.25 (m, 3H).

(E)-((4-methoxybuta-1,3-dien-2-yl)oxy)trimethylsilane (4-103)

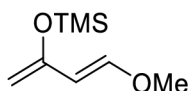

To a mixture of Et₃N (10.05 mL, 86.3 mmol) and ZnCl₂ (0.150 g, 1.1 mmol) was added 4-methoxy-3-buten-2-one in toluene (15 mL). After 5 minutes, Me₃SiCl (10.05 mL, 78.5 mmol) was added rapidly. The reaction mixture is kept below 45 °C by cooling in an ice bath. After 30 min, the stirred solution is heated to 40 °C and the temperature was maintained for 12 hr. The reaction mixture is then cooled to room temperature and poured into Et₂O (30 mL). The

resulting suspension is filtered through Celite. The solvent from ether washings was removed on RVO. The resulting brown oil was used in the next reaction without further purification (6.5 g, 97 %). The obtained ^1H NMR data matched with literature. ^{197}H NMR (400 MHz, Chloroform- d) δ 7.09 – 7.06 (m, 1H), 5.44 (d, $J = 12.4$ Hz, 1H), 4.26 (d, $J = 5.5$ Hz, 2H), 3.16 (s, 3H), 0.23 (s, 9H).

Palacký University in Olomouc

Faculty of Science

Department of Organic Chemistry



Univerzita Palackého
v Olomouci

**Benzo[*d*]thiazole-2-sulfonamides: Their Synthesis and
applications in the field of synthetic method development**

Mgr. František Zálešák

Summary of the Ph.D. Thesis

Supervisor: doc. RNDr. Jiří Pospíšil, Ph.D.

Academic Year: 2020/2021

This Ph.D. thesis was carried out at Department of Organic Chemistry, Faculty of Science, Palacký University Olomouc, within the framework of the Ph.D. program P1417 Chemistry, in the field of study Organic Chemistry, within the years 2017-2021

Ph.D. candidate: Mgr. František Zálešák

Supervisor: doc. RNDr. Jiří Pospíšil, Ph.D.

Opponents: Ing. Aleš Machara, Ph.D.

Ústav organické chemie a biochemie Akademie věd České republiky, v. v. i.,
Flemingovo náměstí 542/2, 160 00 Praha

Dr. Yvan Six

Laboratoire LSO, Ecole Polytechnique - Route de Saclay, 91128 Palaiseau
Cedex, France

The oral defense will take place in in front of the Commission for the Ph.D. Thesis of the study program Chemistry, Organic Chemistry at Department of Organic Chemistry, Faculty of Science, Palacký University Olomouc, 17. listopadu 12, Olomouc

After the defense, the Ph.D. Thesis is available at the Department of Organic chemistry, Faculty of Science, Palacký University Olomouc, 17. Listopadu 12, Olomouc or online at <http://portal.upol.cz>.

1 Introduction

Modern medicinal chemistry focusses on the use of small molecules, which upon interaction with bio-macromolecules may lead to the modification of the biological outcome of cells or organisms. Small chemical entities (molecular probes) are essential in the task to understand the basic interactions of biological systems (chemical biology) and processes. Among others, compounds with sulfonamidic functionality occupy very important positions among such substances, as can be exemplified by their antibacterial,¹ antiretroviral,² diuretical³ and anticonvulsant⁴ properties.

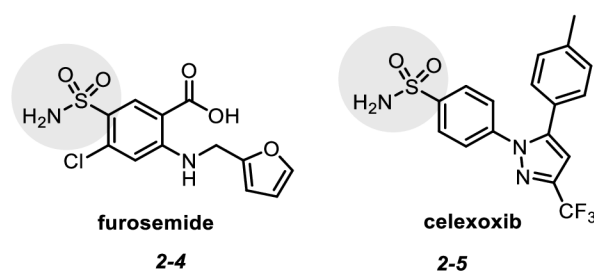
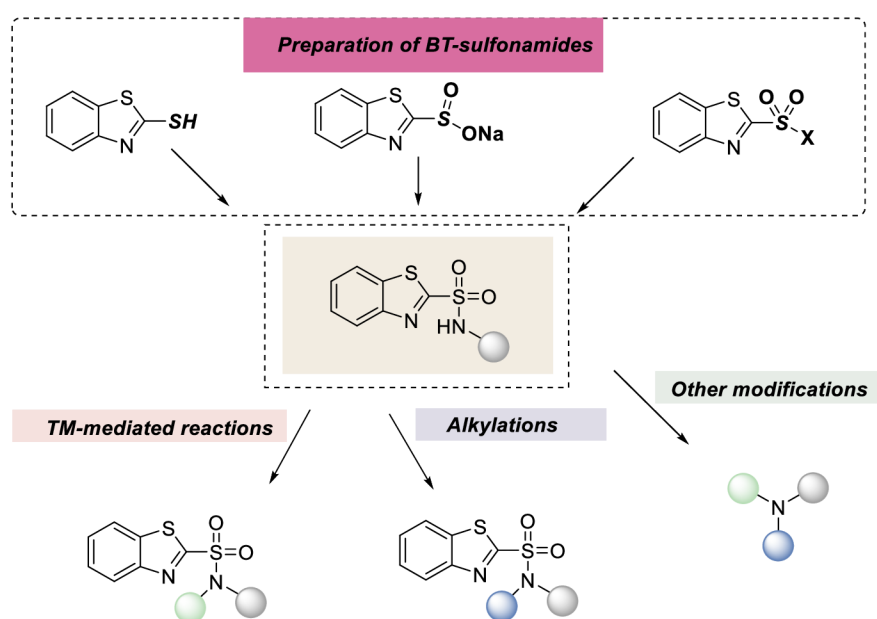

Figure 1 – Examples of sulfonamides used in medicine

Sulfonamides can be formed using several synthetic approaches. The most common is the reaction of amines and sulfonyl halides.^{5,6} However, this method possesses several drawbacks that include low thermal stability of sulfonyl chlorides and low compatibility with other functional groups. Such limitations forced organic chemists to develop novel methodologies in hope to overcome the present limitations and to develop new safe and convenient procedures. The alternative to standard sulfonamide approaches could be considered the oxidative coupling method that uses the reaction of sulfinic salts (thermally and moisture-insensitive solids) with amines in the presence of oxidizing agent.^{7,8} Oxidation is achieved by different dihalogen sources (e.g., NBS or I₂) that in situ generates sulfonyl halides; highly reactive intermediates that can be readily condensed with amines to provide sulfonamides.⁹ Independent approach, that is however rarely used, is the sulfonamide synthesis that explores sulfenamide intermediates.^{10,11} The reason for the low exploration of this approach is its narrow scope caused by the oxidation step. Step that has a very low tolerance towards many functional groups. Despite the importance of sulfonamides and its vast application in medicine, the preparation of sulfonamides substituted with electron-poor heterocycles on the sulfur atom remains an underdeveloped approach and most up-to-date methods struggle with low reaction scope.

2 Aim of the thesis

Our research group has a longstanding interest in the chemistry of benzothiazole (BT) sulfones and their derivatives. The goal of this Theses is to extend the field of our interest towards the chemistry of benzothiazole sulfonamides. The literature search of this topic and class of compounds will quickly reveal that the synthesis of BT-sulfonamides was seldomly reported. We decided to challenge this problem and the aim was to investigate the synthetic routes towards BT-sulfonamides, look closer on the properties of the prepared compounds, to understand their unique reactivity, and finally propose or preliminary determine the possible use of such skeletons in the context of organic synthesis (Scheme 1).



Scheme 1 - General scheme of sulfonamide preparation and their modifications

Part II: Plant secondary metabolites (Lignans and neolignans)

The second part of this Theses was focused on the further development of another field of our research group, plant secondary metabolites. To be more specific, our main interest is focused on the preparation and evaluation of biological properties of neolignan compounds against *Leishmania* parasites and nematodes (*Caenorhabditis elegans*). My goal was to develop a general and versatile synthetic route to neolignane derivatives that would provide “nonsymmetrical” dihydrobenzofurans (Scheme 2).

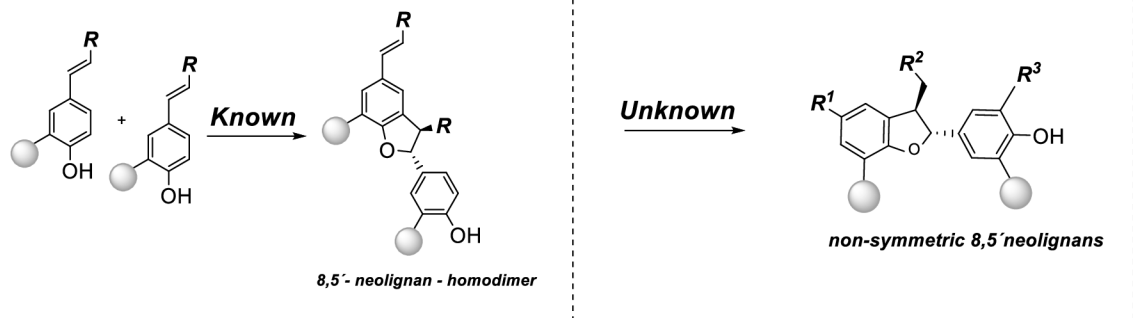

Scheme 2 – General approach towards symmetric and nonsymmetric neolignans

3 Overview of achieved results

3.1 Benzothiazolesulfonamide synthesis

3.1.1 Preparation of sulfonamides from sulfonyl halides

The “classic” retrosynthetic approach that uses a reaction of sulfonyl halides and amines was targeted as a first approach. Thus, the preparation of BT-sulfonyl halides and their applications in sulfonamide preparations, together with the evaluation of the scope and limitation of such methods, were investigated.

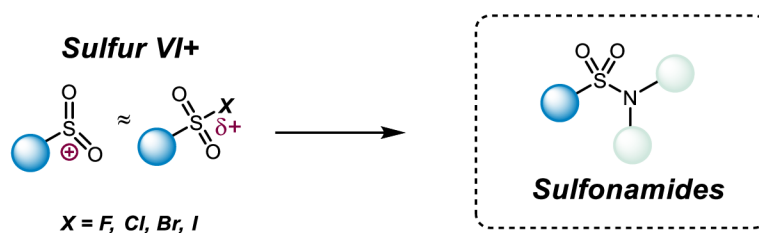
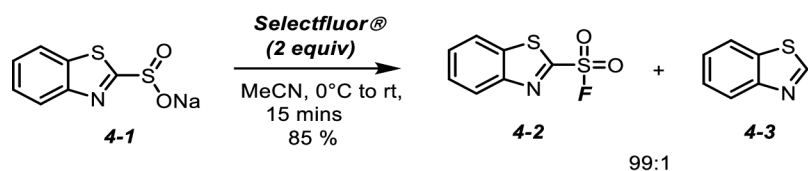

Figure 2 – Sulfonyl halide to sulfonamide transformation

3.1.1.1 Preparation starting from BT SO_2F

Based on the literature reports, we were aware of benzothiazole fluoride **4-2** outstanding stability under standard reaction conditions.^{12,13} Thus, BT-sulfonyl fluoride **4-2** synthesis based on the use of sulfinic salt **4-1** and Selectfluor[®] was developed. Under these reaction conditions, no trace of competitive desulfonylation was observed (Scheme 3).



Scheme 3 – BT-sulfonyl fluoride preparation

Having an easy access to BT SO_2F (**4-2**), the feasibility of so-called SuFEx protocol on this substrate was evaluated. After the optimization, the conditions based on the use of MeCN as a solvent in combination with at least 3 equivalents of amine provided the best reaction yields of sulfonamides. We speculated if one equivalent of benzylamine **4-5** can be replaced with Et₃N or DABCO. Unfortunately, the use of tertiary amines proved to hamper the reaction and, in such cases, only traces of products **4-6** were obtained.

Next, the scope and limitations of the transformation were evaluated. The optimized reaction conditions yielded the desired BT-sulfonamides **4-6a-d** when primary α -unbranched aliphatic amines were used as substrates. However, when sterically more demanding amines (α -branched

primary and secondary amines) were used, the reaction yields dropped significantly. In the case of anilines, the reaction did not provide the desired products, presumably due to a low nucleophilicity of the nitrogen atom. Another reason behind the low reaction yields is the formation of BT-amines **4-7**. Amines **4-7** are the products of competitive attack of amines to electrophilic center of benzothiazole ring. In such case, after the C-addition, the intermediate **4-9** undergoes desulfurylation to give the BT-amine **4-7**. When cyclohexyl diamine is used as a substrate, a complex mixture of mono/di-BT-sulfonamides and mono/di-BT-amines are formed (**4-6h**, **4-8**, **4-9**) (Scheme 4).

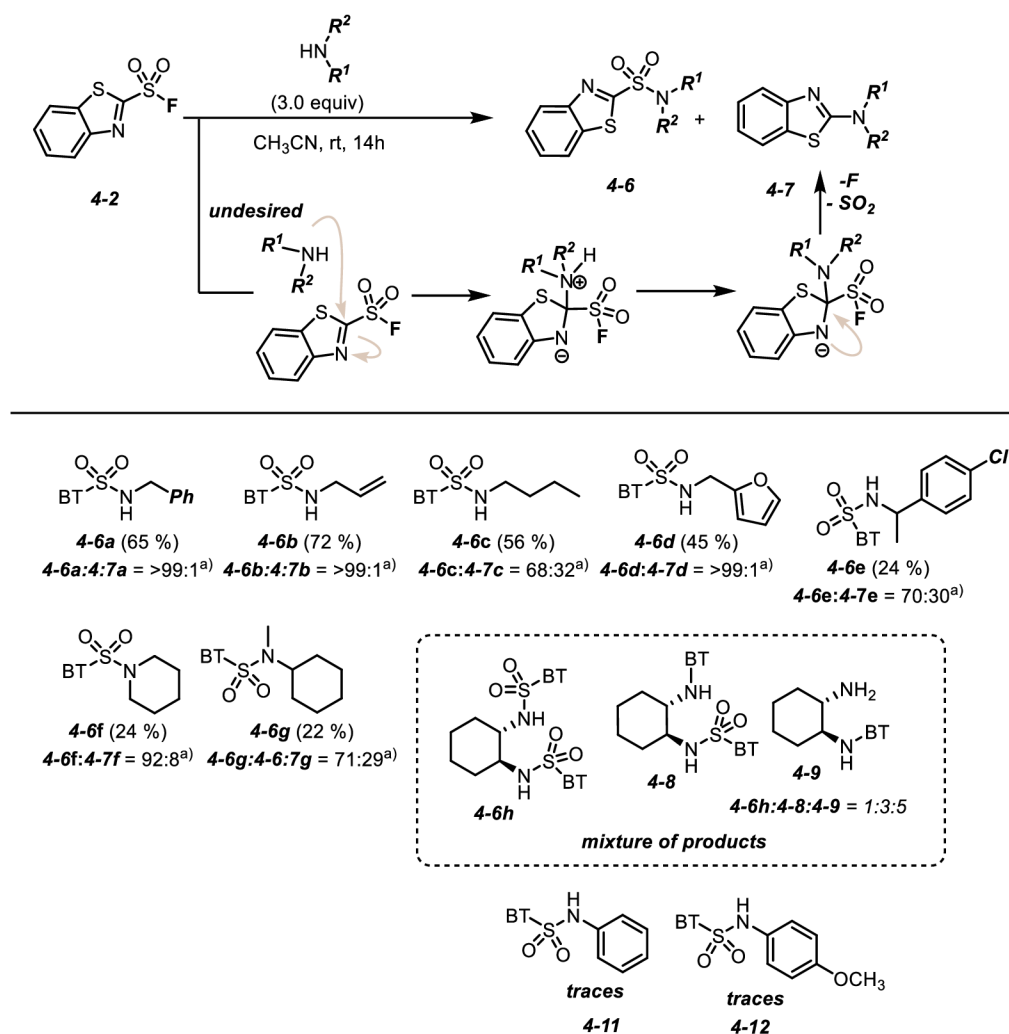

Scheme 4 – Scope and limitation of SuFEx protocol

3.1.2 Oxidative coupling method

Next, we turned our attention to oxidative coupling-based synthesis of sulfonamides. Such approach exploits the stable *sulfur(IV+)* derivatives as a starting material and via their *in-situ* oxidation to sulfonyl halides (*sulfur(VI+)*) in the presence of amines generates the desired BT-sulfonamides **4-6**. Since the sulfonyl halide is generated in situ, it was expected that this reaction

with amine might provide the desired sulfonamides **4-6** quickly, and that the undesired desulfonylation of the sulfonylation intermediate might be negligible (Figure 3).

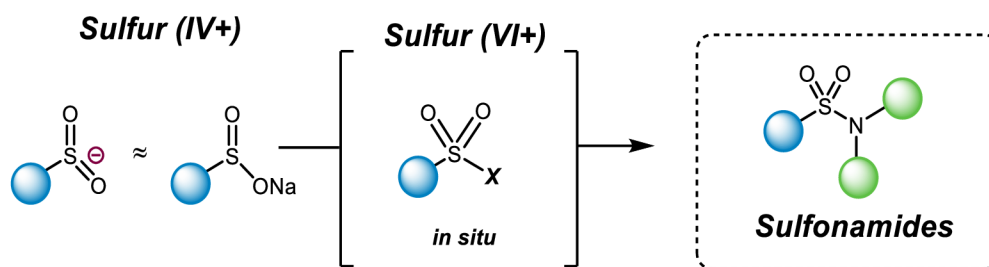
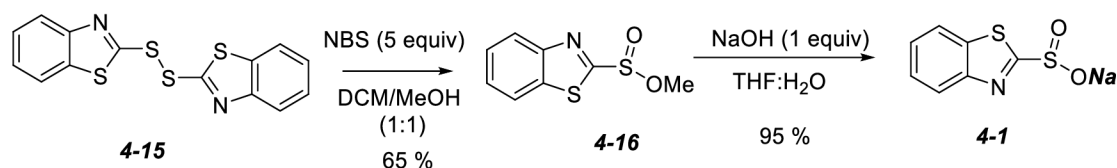

Figure 3 – Oxidative coupling approach to sulfonamides

3.1.2.1 Sulfinic salt synthesis

First, the starting material for this approach (BT-sulfinic salt **4-1**) had to be prepared. For its preparation, the synthetic route starting from bis-sulfone **4-15**, that can be readily transformed to **4-1** in two steps via the sulfinate intermediate **4-16**, was envisaged.



Scheme 5 – BT-sulfinic salt preparation from benzothiazole disulfide

Indeed, the synthesis of sulfinic salt **4-1** was achieved starting from the disulfide **4-15** that was transformed to methyl sulfinate **4-16** using the Brownbridge protocol.¹⁴ The best results were obtained using 5 equivalents of NBS (65 %). Next, the basic hydrolysis of methyl sulfinate **4-16** was performed using standard reaction conditions and the sodium sulfinate **4-1** was obtained in good yields.

3.1.2.2 Sulfonamide synthesis

The oxidative coupling approach was inspired by the work reported by Yan et al.¹⁵ and the recent report by Xian.¹⁶ Those synthetic protocols describe the use of *m*CPBA/TBAB as Br₂ source to achieve sulfonamide **4-29** synthesis. The reaction proceeds the same reaction pathway as shown in the theoretical part of the Thesis (Scheme 6).

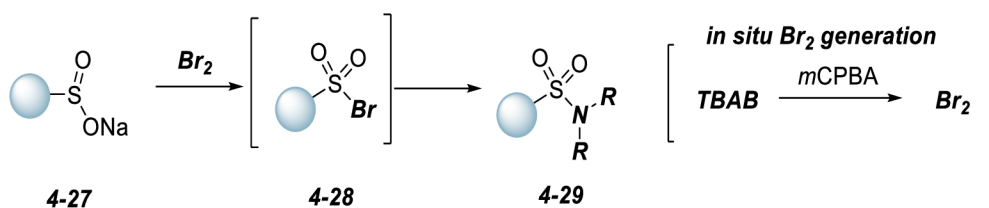

Scheme 6 – General scheme of sulfonamide synthesis based on the oxidative coupling protocol

We optimized/simplified the reaction conditions and we figured out that the role of bromine source and the presence of *m*-chlorobenzoic acid (from *m*CPBA) are the crucial agents that have impact on the reaction progress. It was shown that the presence of *m*-chlorobenzoic acid is also the cause for the sulfinic salt **4-1** decomposition. Molecular bromine provided the products with a minimum amount of impurities; however, the disadvantage of this approach was the problematic quantification of the Br₂ amount when the reactions were carried out in a small scale. Thus, we searched for Br₂ alternatives and identify the NBS as the most suitable one. The use of NBS did solve the important issues – the Br⁺ source and in the same time, it introduced the H⁺ scavenger. Using NBS in THF/EtOH (4:1) mixture, the desired sulfonamide **4-6a** was isolated in 91 % yield.

Having established suitable reaction conditions for the oxidative coupling of sulfinic salt **4-1** with amines, the scope and limitations of the method were evaluated. Primary and secondary aliphatic amines were suitable substrates for targeted transformations and yielded the sulfonamides **4-6a**, **4-6c** in good to excellent yields. It was observed that the reaction conditions tolerate carbonyl group **4-6i**, unsaturated bonds **4-6b**, and aromatic rings **4-6e**, **4-6j**. Furthermore, when amino alcohols were used as the starting material, the method proved to be chemo selective toward amines in the presence of alcohols and yielded N-substituted sulfonamides **4-6k**, **4-6l**. The method is also readily scalable (5 mmol) without any drop in the reaction yield. On the other hand, the reaction conditions were not applicable to anilines. Observed nonreactivity can be attributed to low aniline nitrogen lone pair nucleophilicity. In addition, when anilines several anilines and furan-based amines (electron-rich aromatic rings present) were used as the starting material, the only observable products of the reaction were those attributed to the aromatic ring bromination. When NH₄Cl, amino acid derivatives, or NH₂CN were used as the starting material, the reactions failed to provide the desired products (Table 1).

Table 1 - Scope and limitations of oxidative coupling approach

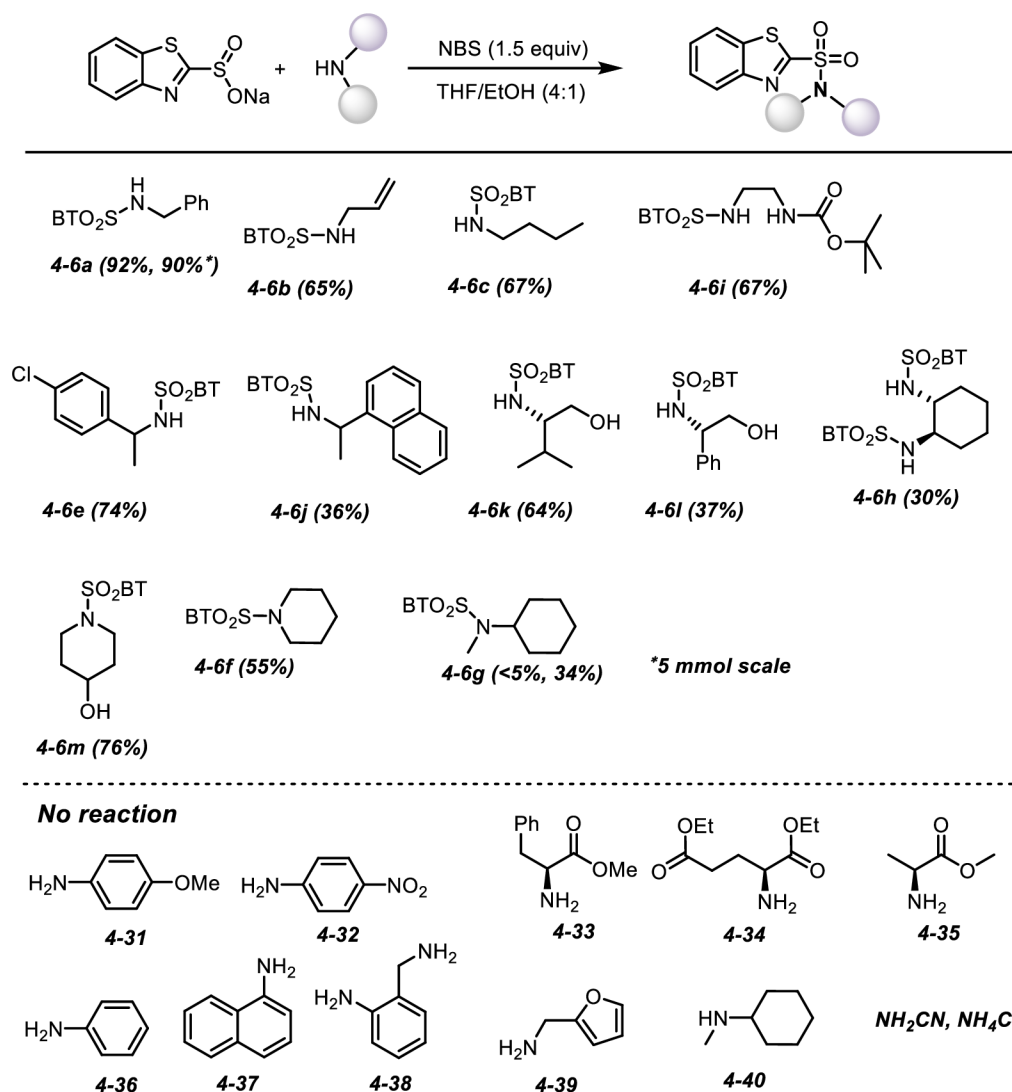

3.1.3 BT-sulfonamide synthesis via S-N coupling followed by oxidation

Having developed the first two, although limited approaches to sulfonamides **4-6**, the third possible way based on the S-N bond forming/oxidation approach was investigated (Scheme 7).

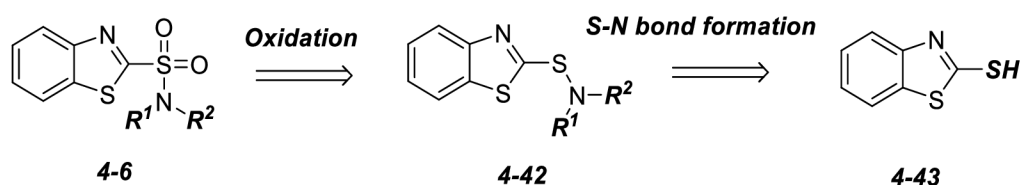

Scheme 7 – Two step approach to BT sulfonamides starting from benzothiazole

3.1.3.1 S-N bond formation

The BT-sulfenamide **4-42** synthesis was first described by Brownbridge et al.¹⁷ who reported the reaction of 2-mercaptobenzothiazole **4-43** with amines in the presence of NCS. The depicted reaction proceeded smoothly and provided sulfenamides **4-42** in good yield and purity. Interestingly, in this transformation, a minimum of 3 equivalents of amine were required to bring the reaction to its completion (Scheme 8). The next step, oxidation, however, was problematic. Our search of ideal oxidative conditions led us to identify the combination of hydrogen peroxide and molybdenum salt as the oxidative mixture of our choice (Scheme 8).

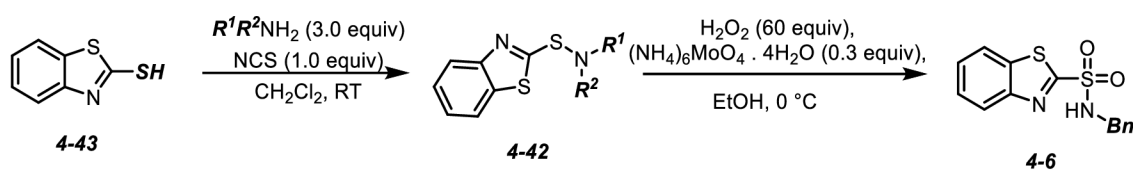

Scheme 8 – Sulfenamide preparation starting from 2-mercaptobenzothiazole and benzylamine

Having optimized reaction conditions, the scope and limitations of the BT-sulfonamides **4-6** synthesis starting from BT-SH **4-43** were evaluated. Using our two-step protocol, various sulfonamides **4-6** were prepared in good to very good yields (Table 2). The first step provides sulfenamides **4-42** in sufficient yield and purity to be used without any additional purification in the next step. The second step is sometimes the troublemaker since the oxidation conditions are not always compatible with the generated sulfenamide **4-42** and/or with sulfonamide **4-6**. In short, primary alkyl amines, α -branched alkylamines, and secondary *N,N*-dialkylamines proved to be suitable substrates for the two-step transformation and yielded the desired BT-sulfonamides in good yields. On the other hand, α -branched benzylamines **4-6j** and **4-6e**, anilines, and NH_4Cl or NH_2CN were found to be incompatible with the reaction conditions. The real importance of this method is in its compatibility with amino acids in both stereo and chemo selectivity viewpoint. Even HCl-salts of amino acid esters could be used as starting materials (**4-6n**, **4-6o**, **4-6p**). The protocol is also readily scalable (up to 10 mmol) without any significant drop in reaction yields.

Table 2 – Scope and limitations of the 4-43 to 4-6 synthesis

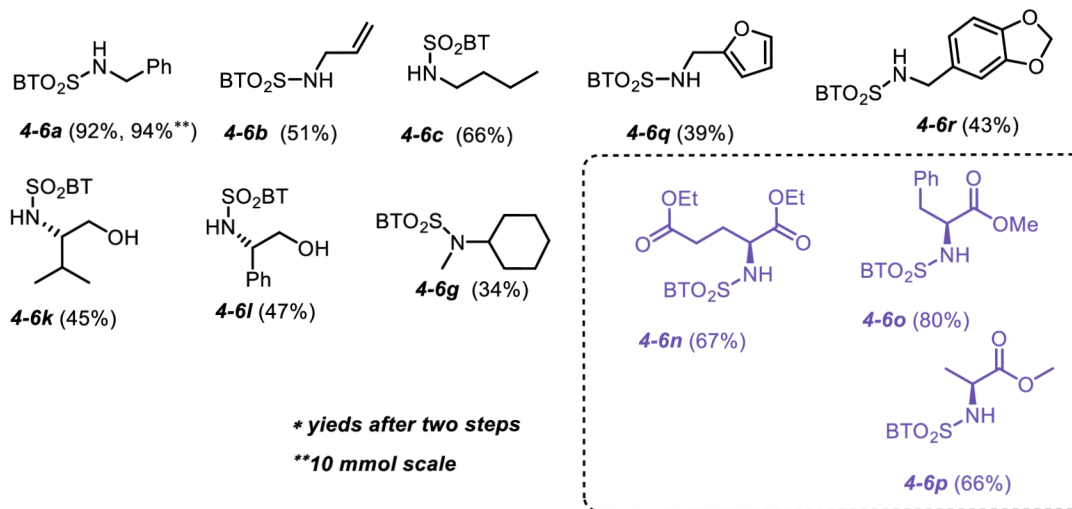
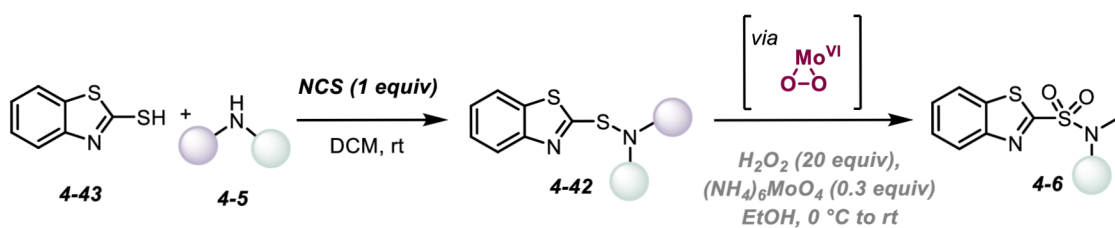

No reaction

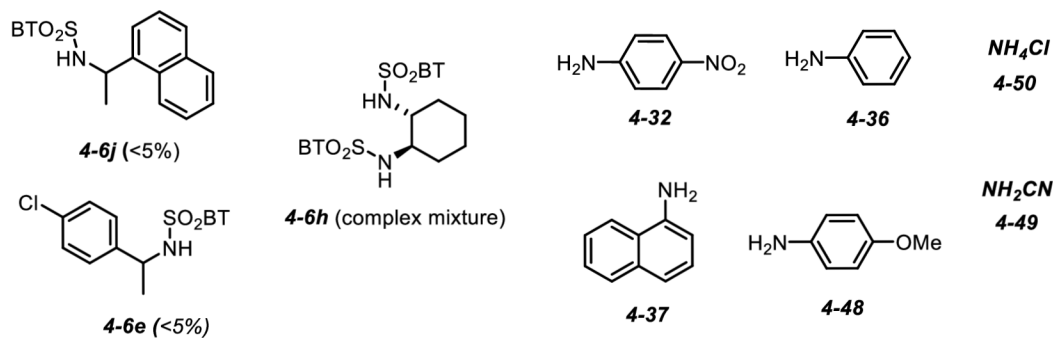

a) all reported reaction yields refer to pure isolated compounds over two steps

b) reactions carried out in 10 mmol scale

3.2 Further modification of sulfonamides

3.2.1 Alkylation of BT sulfonamides

To explore the observed N-H acidity of sulfonamides **4-6**, we focused our attention on base-promoted alkylation and Fukuyama-Mitsunobu reaction (Scheme 9).

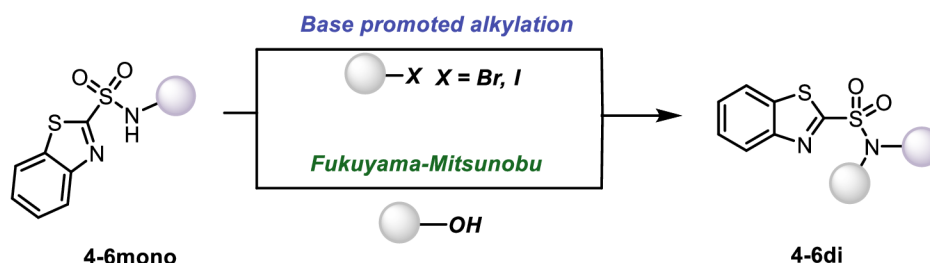

Scheme 9 – BT sulfonamide alkylation

3.2.1.1 Scope and limitations of Fukuyama-Mitsunobu and base-promoted alkylation of BT-sulfonamides

Fukuyama-Mitsunobu alkylation of BT-sulfonamide was achieved by applying the microwave-promoted reaction conditions (100W, 50 °C, 10 min) in THF when sulfonamides were reacted with alcohol (1.0 equiv), DIAD (1.5 equiv) and PPh₃ (1.5 equiv). Interestingly, the transformation was not promoted when the standard heating technique (oil bath) was applied (no product formation and no conversion of sulfonamides). The base-promoted alkylation was compatible with BT-sulfonamides and the best reaction yields were obtained in the presence of excess of alkylating agent and K₂CO₃. Having optimized reaction conditions, the substrate scope and limitation were investigated (Table 3). Both methods were applicable to primary halides/alcohols and yielded the desired *N,N*-dialkylated sulfonamides **4-6** in decent yields. When secondary alcohols were used, Fukuyama-Mitsunobu reaction proceeded in very good yields and with full stereo inversion. In all tested cases, the microwave conditions showed excellent functional group tolerance under Fukuyama-Mitsunobu alkylation conditions. Using this approach, the reaction of chiral sulfonamides with ethyl lactate yielded the *meso*-compound **4-6da**. It should be also noted that in no case we observed the formation of the alcohol elimination side product(s).¹⁸

Table 3 1– Scope and limitations of BT-sulfonamide N-alkylation

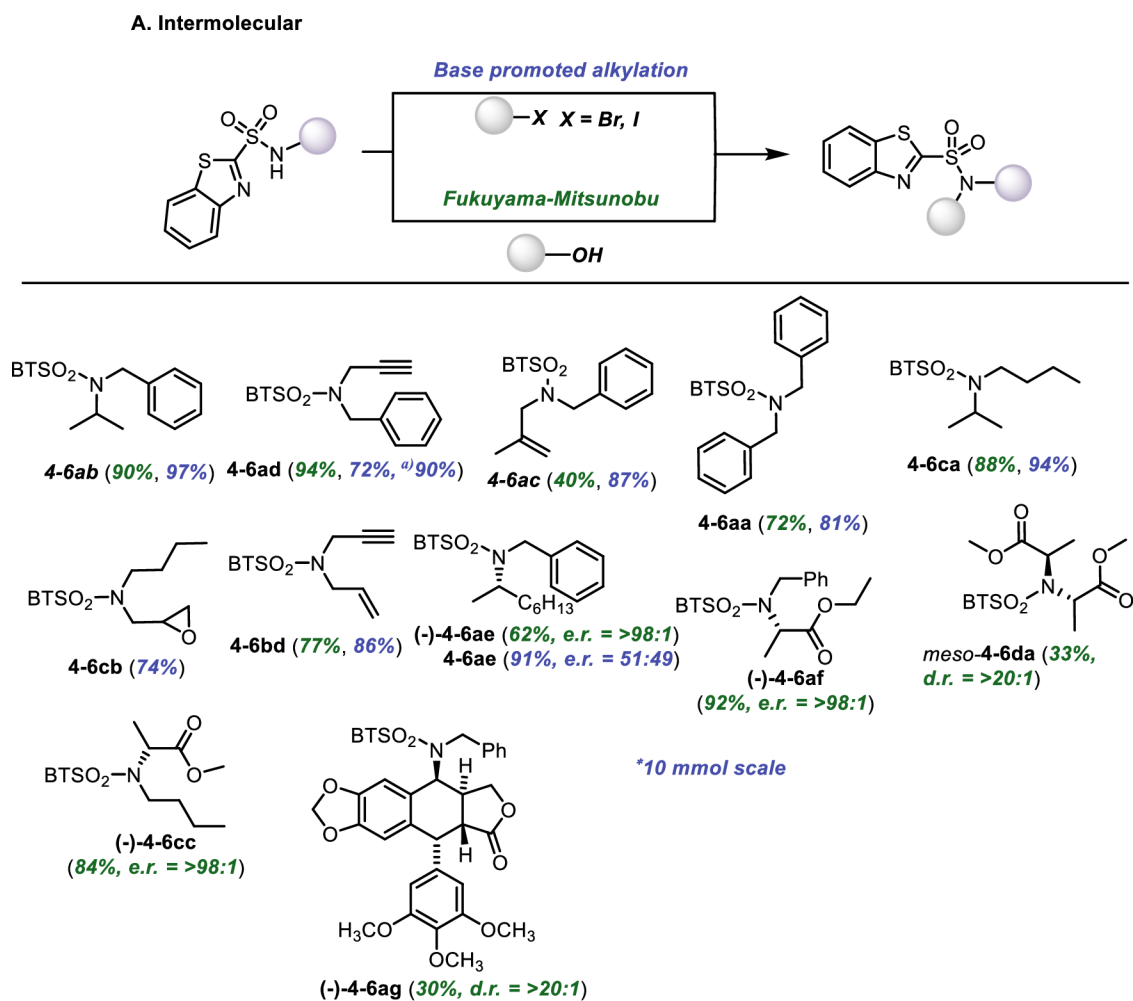

3.2.2 Transition metal promoted reactions

Since we were able to prepare *N,N*-dialkylated sulfonamides **4-6**, we turned our attention towards the preparation of sulfonamides with *N,N*-Csp² carbon bond (*N,N*-alkyl aryl sulfonamides). Based on the literature, two approaches to such compounds were identified. Pd-promoted Buchwald-Hartwig^{19,20} amination, and copper-catalyzed Chan-Lam coupling (Scheme 10).^{21,22}

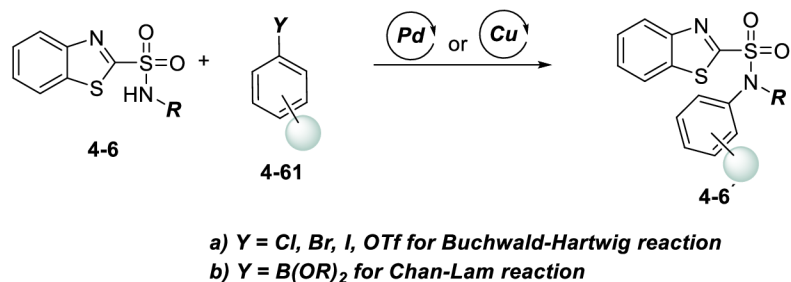

Scheme 10 – Selected General scheme of transition metal catalyzed reaction of BT-sulfonamides

3.2.2.1 Buchwald-Hartwig amination

Buchwald-Hartwig amination is one of the most convenient ways how to forge N-C(sp²) bond. Unfortunately, even after many experiments, we failed to observe formation of the desired *N,N*-alkyl aryl sulfonamide **4-6**. Interestingly, in most cases, only elimination of SO₂ from sulfonamide **4-6** was observed and BT-amine **4-62** was isolated as the only product of the reaction. We found out that Pd(II) is the real promoter of the **4-6** to **4-62** transformation. Detailed investigation of such observations allowed us to propose a plausible reaction mechanism that rationalizes the observed amine **4-62** formation. It was found out that Pd(II) plays under the reaction conditions the role of Lewis acid and presumably activates the intramolecular rearrangement that leads to intermediate **C**. The extrusion of SO₂ from **D** followed by the anion reprotonation/desulfurylation, then yields the desired amine **4-62** (Scheme 11).

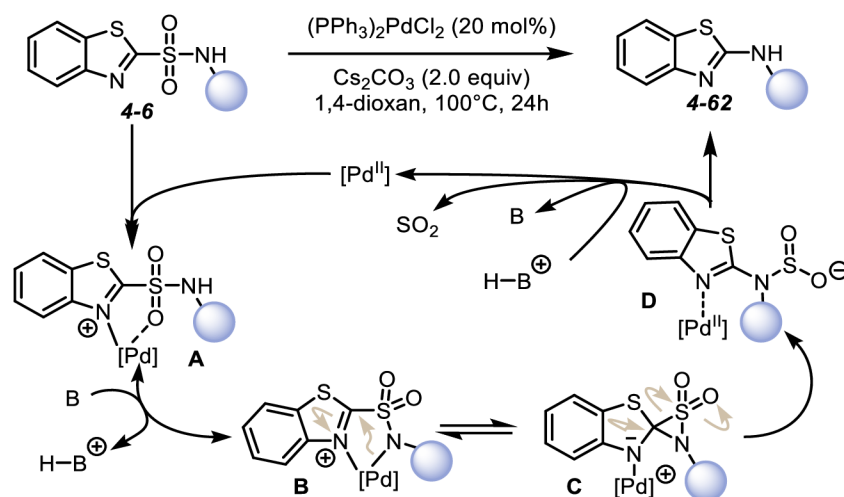

Scheme 11 – Proposed reaction mechanism of the transformation of **4-6** to **4-62**

3.2.2.1.1 Chan-Lam coupling

After unsuccessful attempts to form N-C(sp²) bond using Pd promoted coupling, our attention turned towards copper-promoted Chan-Lam coupling reaction with boronic acids derivatives.^{23,24} After optimization, we were able to summarize our findings about such transformations: **1**) We observed better reaction yields when O₂ (1 atm) was used; **2**) the best yields were obtained when the reaction was carried out in DCE; **3**) The role of several copper sources was investigated to identify a crucial role of counter anion in copper(I) precatalyst. When copper(I) salts with inner space ligand as chloride, bromide, iodide, nitrile, or acetate, were used, only a low conversion of the starting sulfonamide was observed. Such observation is in agreement with the literature,²² suggesting that substrates with low nucleophilicity are very slow in the ligand exchange. Thus, we decided to use a cationic copper source to increase the

rate of exchange (hexafluorophosphate counter anion); **4**) The role of the ligand proved to be crucial since only TMEDA ligands (bidentate) in the optimized amount (4 equiv) provided the desired products in good yields (Scheme 12).²²

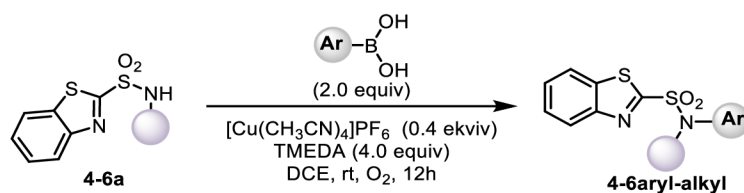

Scheme 12 – Chan-Lam coupling of BT-sulfonamides with phenyl boronic acid

Having optimized the reaction conditions for the coupling of phenyl boronic acid **4-61b** and *N*-benzyl sulfonamide **4-6a**, we extended the optimized conditions to other substrates to evaluate their scope and limitations (Table 4). Unfortunately, scope of the Chan-Lam coupling reaction proved to be rather narrow and the desired products were obtained only when unsubstituted aromatic boronic acids **4-61b** were used as a starting material. Only boronic acid with

4-biphenyl, 3-methoxyphenyl, and 3-fluoro and 4-halogen substitution provided the desired products. 4-carboxylic acid or ester-substituted phenyl boronic acid, 4-methoxyphenyl, or styryl derivatives did not yield the desired products. The only detected products of the reaction in such cases were the products of boronic acid homocoupling (Table 4).

Table 4- Scope and limitations of Chan-Lam coupling

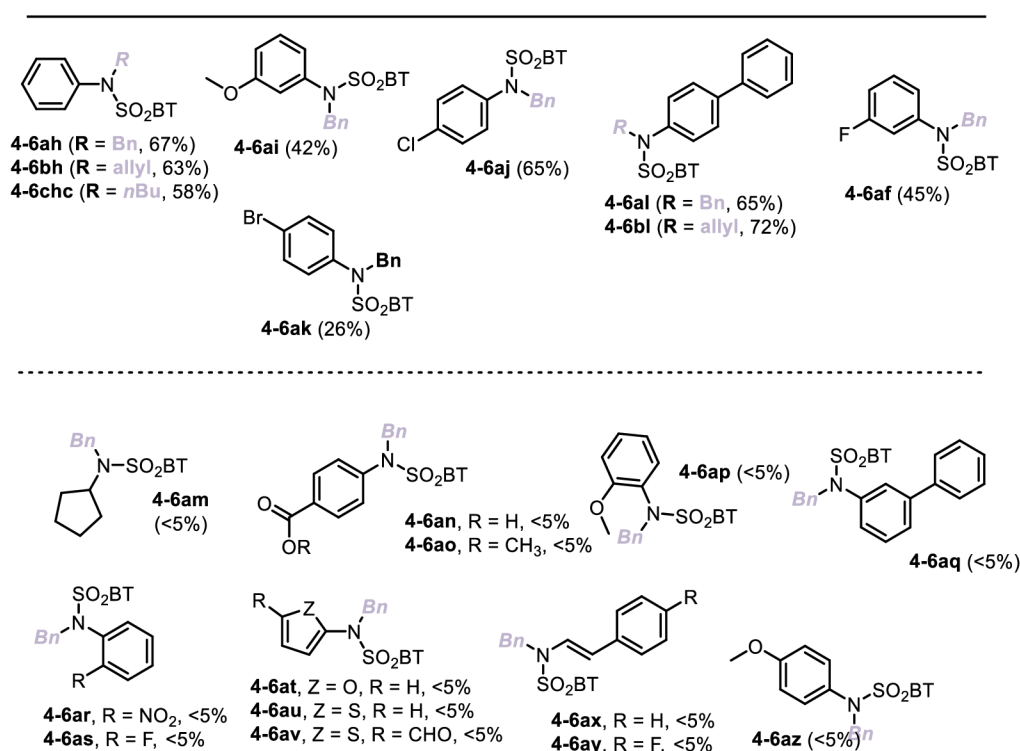

3.2.3 Smiles rearrangement

Our previous experience in the Smiles rearrangement area led us to propose the use of Smiles rearrangements in the context of benzothiazole sulfonamide derivatives. We proved that the generated carbanion is configurational stable under the reaction conditions (KHMDS (1.5 equiv), 18-crown-6 (3.5 equiv), THF, -85 °C, 15 min) and that it undergoes intramolecular transformation (attack to benzothiazole electrophilic center) prior to its epimerization (formation of enolate). Interestingly, when freshly *in situ* prepared LHMDS was generated prior the reaction, the formation of the rearrangement product **4-6af** proceeded as well, however, the rearranged product was isolated as the opposite enantiomer (90:10 e.r., the opposite configuration in the case of KHMDS). Unfortunately, all attempts for absolute stereochemistry identification failed so far (Scheme 13).

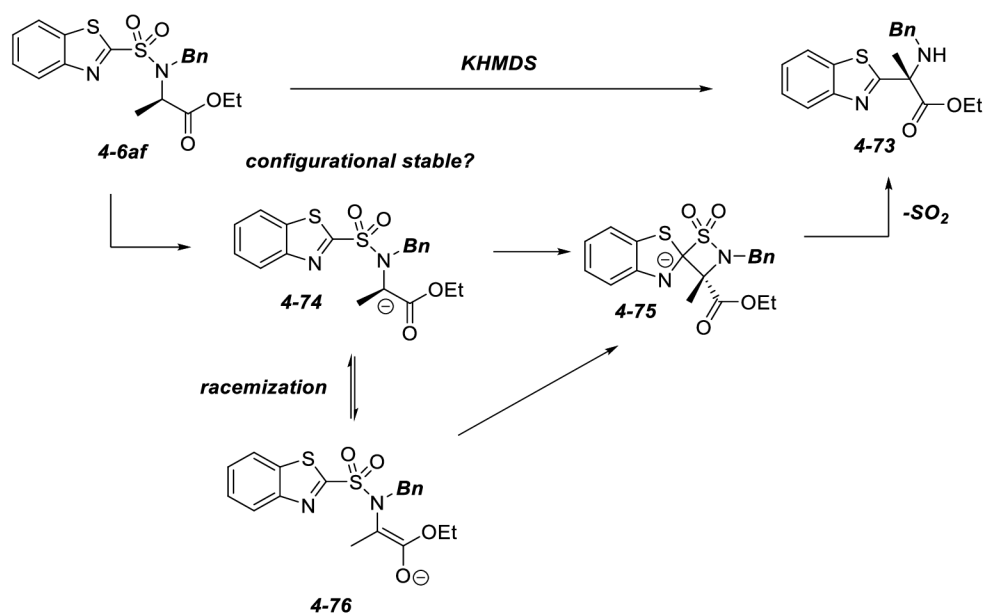

Scheme 13 – Proposed Smiles rearrangement based intermolecular transformation of α -amino acid derivatives

3.3 Boehmenans – Neolignans of benzofuran family

3.3.1.1 Neolignan core formation

As the benzofuran heterocycle **4-124** is the key building block of Boehmenan neolignan family, our goal was to investigate and develop a general route towards skeleton **4-128** (Scheme 14).

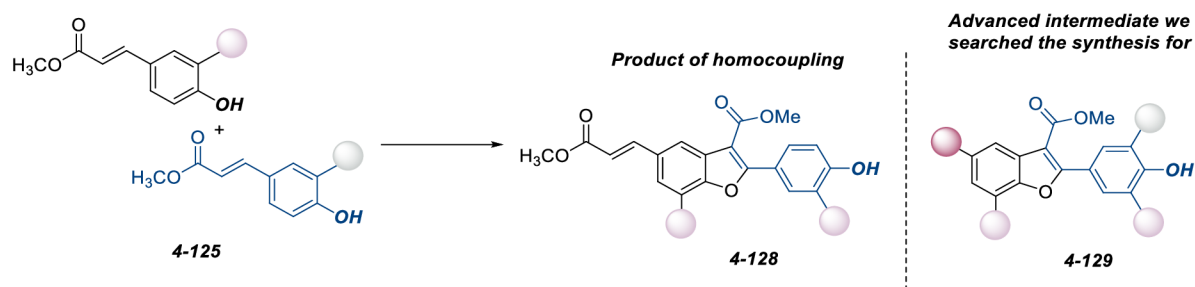

Scheme 14 – (A) General scheme for homocoupling reaction and (B) targeted modulable skeleton

First, the literature report-based metal-catalyzed and enzymatic homocoupling was attempted. Unfortunately, such homocoupling approach proved to be very problematic (scale up) and yielded dihydrobenzofurans in low reaction yields (7 - 22 %).

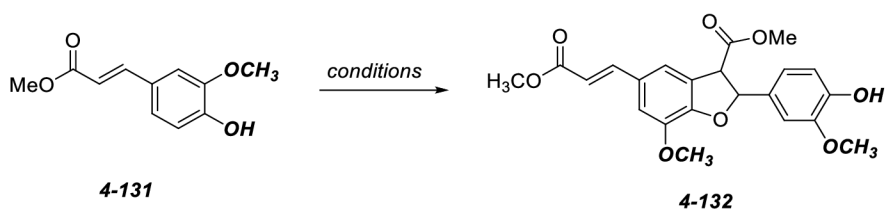

Scheme 15 – Biomimetic approach towards dihydrobenzofuran motive

3.3.2 Cross dehydrogenative coupling (CDC)

We turned our attention towards CDC coupling that should be suitable for divergent synthesis of benzofuran **4-135**. In our approach, we explored several reaction conditions developed by Guo²⁵ and Parnes²⁶ and applied them to the CDC coupling of methyl ferulate **4-139** and ketoester **4-140**. Unfortunately, the desired product **4-141** was obtained only in low yield. The best result (36 %) was obtained when the combination of Fe³⁺/DTBP was used (FeCl₃ (10 mol%), NHPI (5 mol%) DTBP (2.5 equiv), DCE, 70 °C) (Scheme 16).²⁷

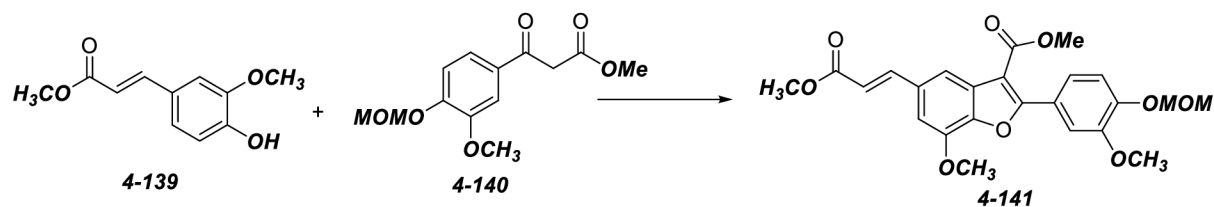

Scheme 16 – Cross dehydrogenative coupling

To understand the poor reaction yields, we performed several control experiments that suggested that the formation of radicals in *the ortho* position with respect to the starting phenol group in **4-142a** is favored due to the presence of an unsaturated chain. The presence of methoxy

group however presumably stabilize “too much” generated radical that slowly undergoes to degradation (Scheme 17).

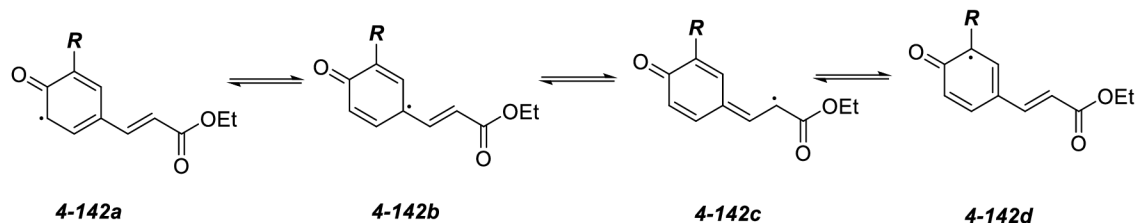

Scheme 17 – Free radical stabilization

Unfortunately, Boehmenan neolignans possess several electron-donating substituents on both aromatic rings. Thus, CDC coupling-based approach to Boehmenan family of neolignans proved to be unsuitable. Different types of (retro)synthetic approach to such class of compounds thus must be designed to successfully achieve the synthesis of targeted molecules.

4 Summary and perspective

In the presented Thesis, I have shown the detailed investigation of BT-sulfonamide preparation. Three main synthetic approaches were successfully investigated, and the scope and limitations of each method were evaluated. Obtained results suggested and highlighted a unique place of benzothiazole sulfonamide derivatives in the sulfonamidic family from the synthetic point of view together with their unique reactivity (Scheme 18). Unfortunately, the conditions we optimized for the benzothiazolesulfonamidic moiety proved to be difficult to transpose to other electron-poor heterocycles (pyrimidine, phenyltetrazole). The unique reactivity of these compounds is best reflected in very specific reaction conditions that had to be developed for well-established reactions as, e.g., Fukuyama-Mitsunobu alkylation. The mild conditions required for its introduction along with chemo selective cleavage of the benzothiazole sulfonyl moiety, however, opens the door for its use as an amino group protecting group that is suitable for late-stage modification. Unfortunately, we failed to find a robust reaction transformation for transition metal catalyzed reactions, since Buchwald-Hartwig coupling failed to give products and the scope of Chan-Lam coupling is very limited. Finally, preliminary data showed that Smiles rearrangement of BT-sulfonamides of amino acids yields an interesting homochiral α -quaternary centers bearing heteroaryl amino acids.

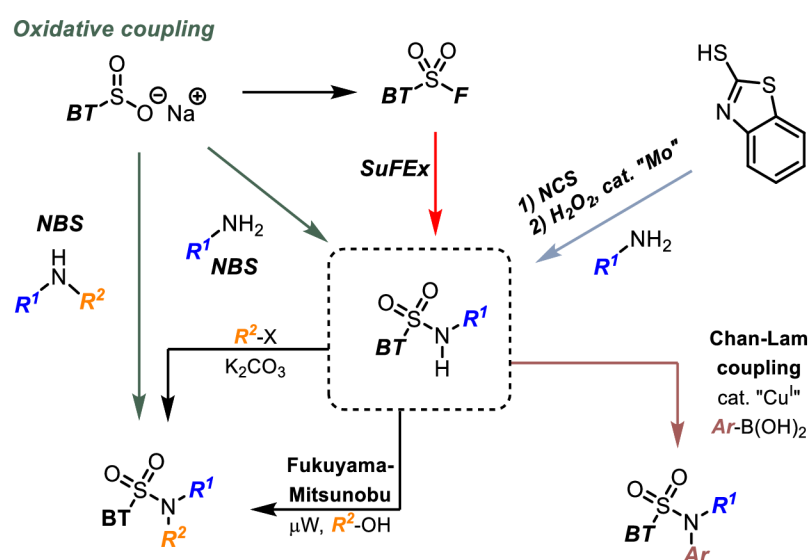

Scheme 18 – Overview of general routes to BT-sulfonamides

Next, we were interested in the use of BT-sulfonamides as HBD donors in organic synthesis. So far, only limited data were obtained. In this context, more work must be done, but it is believed that a unique and readily available access to these HBD catalysts is a good starting

point for their further development and application. The pK_a value of such HBD donors is presumed to be readily modifiable and predictable.

Despite the great potential of CDC coupling in the benzofuran synthesis, it was demonstrated that such an approach fails in the case of Boehmenan-like compounds. Currently, in our group we shifted our attention to transition metal-catalyzed transformations that might bring the solution to the desired modular synthesis approach that will allow us to prepare a chemical library of benzofuran derivatives suitable for further biological properties evaluation.

5 Literature

- (1) Hughes, W. T.; Killmar, J. Monodrug Efficacies of Sulfonamides in Prophylaxis for Pneumocystis Carinii Pneumonia. *Antimicrob. Agents Chemother.* **1996**, *40* (4), 962 LP – 965. <https://doi.org/10.1128/AAC.40.4.962>.
- (2) Gentile, I.; Buonomo, A. R.; Borgia, F.; Zappulo, E.; Castaldo, G.; Borgia, G. MK-5172: A Second-Generation Protease Inhibitor for the Treatment of Hepatitis C Virus Infection. *Expert Opin. Investig. Drugs* **2014**, *23* (5), 719–728. <https://doi.org/10.1517/13543784.2014.902049>.
- (3) L. Romero, D.; A. Morge, R.; J. Genin, M.; Biles, C.; Busso, M.; Resnick, L.; W. Althaus, I.; Reusser, F.; C. Thomas, R.; G. Tarpley, W. Bis(Heteroaryl)Piperazine (BHAP) Reverse Transcriptase Inhibitors: Structure-Activity Relationships of Novel Substituted Indole Analogs and the Identification of 1-[(5-Methanesulfonamido-1H-Indol-2-Yl)Carbonyl]-4-[3-[(1-Methylethyl)Amino]Pyridinyl]Piperaz. *J. Med. Chem.* **2002**, *36* (10), 1505–1508. <https://doi.org/10.1021/jm00062a027>.
- (4) Welling, P. G. Pharmacokinetics of the Thiazide Diuretics. *Biopharm. Drug Dispos.* **1986**, *7* (6), 501–535. <https://doi.org/10.1002/bdd.2510070602>.
- (5) Wang, Y.; S. Guziec, F. A Convenient Reductive Deamination (Hydrodeamination) of Aromatic Amines. *J. Org. Chem.* **2001**, *66* (25), 8293–8296. <https://doi.org/10.1021/jo010681w>.
- (6) Serpier, F.; Brayer, J.-L.; Folléas, B.; Darses, S. Access to Polyfunctionalized Chiral Piperidines through Enantioselective Addition–Carbocyclization Cascade Reaction Catalyzed by a Rhodium(I)–Diene Complex. *Org. Lett.* **2015**, *17* (21), 5496–5499. <https://doi.org/10.1021/acs.orglett.5b02858>.
- (7) Wu, S.-X.; Zhang, Y.-K.; Shi, H.-W.; Yan, J. Iodine-Catalyzed N-Sulfonylation of Benzotriazoles with Sodium Sulfinates under Mild Conditions. *Chinese Chem. Lett.* **2016**, *27* (9), 1519–1522. <https://doi.org/https://doi.org/10.1016/j.ccllet.2016.03.024>.
- (8) Fu, L.; Bao, X.; Li, S.; Wang, L.; Liu, Z.; Chen, W.; Xia, Q.; Liang, G. Synthesis of Sulfonamides from Azoles and Sodium Sulfinates at Ambient Temperature. *Tetrahedron* **2017**, *73* (17), 2504–2511. <https://doi.org/https://doi.org/10.1016/j.tet.2017.03.038>.

- (9) Jiang, H.; Tang, X.; Xu, Z.; Wang, H.; Han, K.; Yang, X.; Zhou, Y.; Feng, Y.-L.; Yu, X.-Y.; Gui, Q. TBAI-Catalyzed Selective Synthesis of Sulfonamides and β -Aryl Sulfonyl Enamines: Coupling of Arenesulfonyl Chlorides and Sodium Sulfinates with Tert-Amines. *Org. Biomol. Chem.* **2019**, *17* (10), 2715–2720. <https://doi.org/10.1039/C8OB02992J>.
- (10) Dou, Y.; Huang, X.; Wang, H.; Yang, L.; Li, H.; Yuan, B.; Yang, G. Reusable Cobalt-Phthalocyanine in Water: Efficient Catalytic Aerobic Oxidative Coupling of Thiols to Construct S–N/S–S Bonds. *Green Chem.* **2017**, *19* (11), 2491–2495. <https://doi.org/10.1039/C7GC00401J>.
- (11) Tang, S.; Liu, Y.; Li, L.; Ren, X.; Li, J.; Yang, G.; Li, H.; Yuan, B. Scalable Electrochemical Oxidant-and Metal-Free Dehydrogenative Coupling of S–H/N–H. *Org. Biomol. Chem.* **2019**, *17* (6), 1370–1374. <https://doi.org/10.1039/C8OB03211D>.
- (12) Wright, S. W.; Hallstrom, K. N. A Convenient Preparation of Heteroaryl Sulfonamides and Sulfonyl Fluorides from Heteroaryl Thiols. *J. Org. Chem.* **2006**, *71* (3), 1080–1084. <https://doi.org/10.1021/jo052164+>.
- (13) Nielsen, M. K.; Ugaz, C. R.; Li, W.; Doyle, A. G. PyFluor: A Low-Cost, Stable, and Selective Deoxyfluorination Reagent. *J. Am. Chem. Soc.* **2015**, *137* (30), 9571–9574. <https://doi.org/10.1021/jacs.5b06307>.
- (14) Brownbridge, P.; Jowett, I. C. “One-Pot” Synthesis of Sulphinic Esters from Disulphides. *Synthesis (Stuttg)*. **1988**, *1988* (03), 252–254. <https://doi.org/10.1055/s-1988-27535>.
- (15) Wu, S.; Zhang, Y.; Zhu, M.; Yan, J. One-Pot Synthesis of Sulfonamides from Sodium Sulfinates and Amines via Sulfonyl Bromides. *Synlett* **2016**, *27* (19), 2699–2704. <https://doi.org/10.1055/s-0036-1588298>.
- (16) Day, J. J.; Neill, D. L.; Xu, S.; Xian, M. Benzothiazole Sulfinates: A Sulfinic Acid Transfer Reagent under Oxidation-Free Conditions. *Org. Lett.* **2017**, *19* (14), 3819–3822. <https://doi.org/10.1021/acs.orglett.7b01693>.
- (17) Brownbridge, P.; Jowett, I. C. ON THE REACTION OF BENZOTHIAZOL-2-YL SULPHENAMIDES WITH PHOSPHITES. *Phosphorous Sulfur Relat. Elem.* **1988**, *35* (3–4), 311–318. <https://doi.org/10.1080/03086648808074335>.

- (18) Fletcher, S. The Mitsunobu Reaction in the 21st Century. *Org. Chem. Front.* **2015**, *2* (6), 739–752. <https://doi.org/10.1039/C5QO00016E>.
- (19) Dorel, R.; Grugel, C. P.; Haydl, A. M. The Buchwald–Hartwig Amination After 25 Years. *Angew. Chemie Int. Ed.* **2019**, *58* (48), 17118–17129. <https://doi.org/10.1002/anie.201904795>.
- (20) Forero-Cortés, P. A.; Haydl, A. M. The 25th Anniversary of the Buchwald–Hartwig Amination: Development, Applications, and Outlook. *Org. Process Res. Dev.* **2019**, *23* (8), 1478–1483. <https://doi.org/10.1021/acs.oprd.9b00161>.
- (21) Zu, W.; Liu, S.; Jia, X.; Xu, L. Chemoselective N-Arylation of Aminobenzene Sulfonamides via Copper Catalysed Chan–Evans–Lam Reactions. *Org. Chem. Front.* **2019**, *6* (9), 1356–1360. <https://doi.org/10.1039/C8QO01313F>.
- (22) Vantourout, J. C.; Miras, H. N.; Isidro-Llobet, A.; Sproules, S.; Watson, A. J. B. Spectroscopic Studies of the Chan-Lam Amination: A Mechanism-Inspired Solution to Boronic Ester Reactivity. *J. Am. Chem. Soc.* **2017**, *139* (13), 4769–4779. <https://doi.org/10.1021/jacs.6b12800>.
- (23) Zu, W.; Liu, S.; Jia, X.; Xu, L. Chemoselective: N -Arylation of Aminobenzene Sulfonamides via Copper Catalysed Chan-Evans-Lam Reactions. *Org. Chem. Front.* **2019**, *6* (9), 1356–1360. <https://doi.org/10.1039/c8qo01313f>.
- (24) Vantourout, J. C.; Li, L.; Bendito-Moll, E.; Chhabra, S.; Arrington, K.; Bode, B. E.; Isidro-Llobet, A.; Kowalski, J. A.; Nilson, M. G.; Wheelhouse, K. M. P.; Woodard, J. L.; Xie, S.; Leitch, D. C.; Watson, A. J. B. Mechanistic Insight Enables Practical, Scalable, Room Temperature Chan-Lam N-Arylation of N-Aryl Sulfonamides. *ACS Catal.* **2018**, *8* (10), 9560–9566. <https://doi.org/10.1021/acscatal.8b03238>.
- (25) Guo, X.; Yu, R.; Li, H.; Li, Z. Iron-Catalyzed Tandem Oxidative Coupling and Annulation: An Efficient Approach to Construct Polysubstituted Benzofurans. *J. Am. Chem. Soc.* **2009**, *131* (47), 17387–17393. <https://doi.org/10.1021/ja907568j>.
- (26) Parnes, R.; A. Kshirsagar, U.; Werbeloff, A.; Regev, C.; Pappo, D. Ligand-Controlled Iron-Catalyzed Coupling of α -Substituted β -Ketoesters with Phenols. *Org. Lett.* **2012**, *14* (13), 3324–3327. <https://doi.org/10.1021/ol301297k>.
- (27) Barbušáková, Z.; Kozubíková, H.; Zálešák, F.; Doležal, K.; Pospíšil, J. General

Approach to Neolignan-Core of the Boehmenan Natural Product Family. *Monatshefte für Chemie - Chem. Mon.* **2018**, *149* (4), 737–748. <https://doi.org/10.1007/s00706-017-2132-4>.