

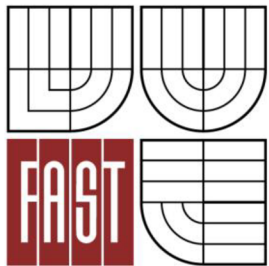

**VYSOKÉ UČENÍ TECHNICKÉ V BRNĚ**  
BRNO UNIVERSITY OF TECHNOLOGY



**FAKULTA STAVEBNÍ**  
**ÚSTAV POZEMNÍHO STAVITELSTVÍ**

FACULTY OF CIVIL ENGINEERING  
INSTITUTE OF BUILDING STRUCTURES

## FOLDER A – BASIC DOCUMENTS

**BAKALÁŘSKÁ PRÁCE**  
BACHELOR'S THESIS

**AUTOR PRÁCE**  
AUTHOR

Michal Reiter

**VEDOUCÍ PRÁCE**  
SUPERVISOR

doc. Ing. JIŘÍ SEDLÁK, CSc.

## **FOLDER CONTENT**

- a) FRONT SHEET
  - b) TASK OF THE BACHELOR THESIS
  - c) ABSTRACT AND KEYWORDS IN CZECH AND ENGLISH LANGUAGE
  - d) BIBLIOGRAPHIC QUOTATION OF VŠKP
  - e) DECLARATION OF ORIGINALITY
  - f) ACKNOWLEDGEMENT
  - g) CONTENTS
  - h) INTRODUCTION
  - i) LIST OF USED SOURCES AND MATERIALS
  - j) LIST OF USED ABBREVIATIONS AND SYMBOLS
- ADJUSTED DOCUMENT: POPISNÝ SOUBOR ZÁVĚREČNÉ PRÁCE





VYSOKÉ UČENÍ TECHNICKÉ V BRNĚ  
BRNO UNIVERSITY OF TECHNOLOGY

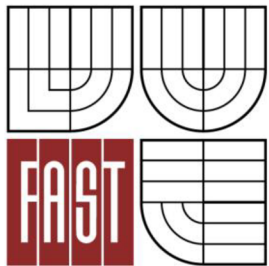

FAKULTA STAVEBNÍ  
ÚSTAV POZEMNÍHO STAVITELSTVÍ

FACULTY OF CIVIL ENGINEERING  
INSTITUTE OF BUILDING STRUCTURES

## LOW ENERGY DETACHED HOUSE

LOW ENERGY DETACHED HOUSE

BAKALÁŘSKÁ PRÁCE  
BACHELOR'S THESIS

AUTOR PRÁCE  
AUTHOR

Michal Reiter

VEDOUCÍ PRÁCE  
SUPERVISOR

doc. Ing. JIŘÍ SEDLÁK, CSc.

BRNO 2012



# VYSOKÉ UČENÍ TECHNICKÉ V BRNĚ FAKULTA STAVEBNÍ

**Studijní program** B3607 Civil Engineering  
**Typ studijního programu** Bakalářský studijní program s výukou v anglickém jazyce a prezenční formou studia  
**Studijní obor** 3608R001 Pozemní stavby  
**Pracoviště** Ústav pozemního stavitelství

## ZADÁNÍ BAKALÁŘSKÉ PRÁCE

**Student** Michal Reiter  
**Název** Low energy detached house  
**Vedoucí bakalářské práce** doc. Ing. Jiří Sedlák, CSc.  
**Datum zadání bakalářské práce** 30. 11. 2011  
**Datum odevzdání bakalářské práce** 25. 5. 2012  
V Brně dne 30. 11. 2011

  
.....  
doc. Ing. Miroslav Novotný, CSc.  
Vedoucí ústavu

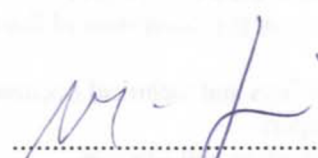

  
.....  
prof. Ing. Rostislav Drochytka, CSc.  
Děkan Fakulty stavební VUT

## **Podklady a literatura**

- Directives of the Dean No. 9/2009
- Building Programme defined by the text-based description
- Architectural study or sketches of the building, site conditions and requirements
- Technical Specifications, Eurocodes and National/European standards for building design and civil engineering
- Building Code No 183/2006 Sb., Public Notice No. 499/2006 Sb., Public Notice No. 268/2009 Sb. for the Czech students or keep terms of national Building Codes legislation in own country.

## **Zásady pro vypracování**

Architectural and structural design of the building as required by building codes in the documentation for building permit.

Graphic requirements and design documentation of the project:

- Drawings will be graphically elaborated on a white paper with the PC graphic editor
- Drawings will be equipped by unified description field (label) for each drawing unit. For the project defence and examination committee drawings will be folded and fix up into specific paper coverings and put into fixed cover table with required lettering for Bachelor project (BP)
- Supplements of text and calculation sheets will be put in writing by technical lettering, typed print or PC text editors
- Editing and form of the main cover table in the format A4 (see sample for the BP at the Institute ÚPST). Cover tables for BP will be from the hard paper and covered by black fabric and head plate will be described and printed with gilded writing (letters)
- BP will be completed into three parts A, B and C and put into the cover tables
- Individual parts of BP will be equipped by description field (label) in the front page and with the table of contents inside.

## **Předepsané přílohy**

Licenční smlouva o zveřejňování vysokoškolských kvalifikačních prací

A/ Basic documents

1. Assignments of Bachelor Project
2. Documents from the supervisor of Bachelor Project

B/ Studies

C/ Project drawings and technical documents (project in the level for realization)

1. Technical report
2. Technical situation and site plan
3. Foundations
4. Ground floor plans
5. Roof constructions, roofing and drainage system
6. Vertical cross sections
7. Front and side views
8. Building details and technical specifications of building components, external constructions and floor compositions
9. Assembly plan of precast structures or formwork drawings of cast in situ concrete
10. Report of fire safety and protection of building structures
11. Thermal assessment of external constructions of the building.

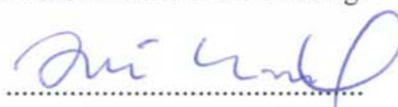

doc. Ing. Jiří Sedlák, CSc.  
Vedoucí bakalářské práce

### **Abstract in Czech and English language**

Předmětem mé bakalářské práce je vypracování dokumentace projektu novostavby nízkoenergetického rodinného domu v Olomouci. Objekt je řešen jako dvoupodlažní, nepodsklepená stavba obsahující jednu bytovou jednotku pro čtyřčlennou rodinu. Společně s garáží, která je součástí domu tvoří jeden celek. Střecha je navržena plochá, jednoplášťová. Projektová dokumentace je zpracována dle platných norem.

The subject of my bachelor's thesis is elaboration of the project in the level for realization of low energy detached house in Olomouc. Object is designed as a two-storey structure without basement containing a dwelling unit for four member family. Together with garage which is a part of the house forms one whole piece. Structure has a flat roof construction. Project documentation is elaborated according to valid standards.

### **Keywords in Czech and English language**

Nízkoenergetický rodinný dům, dvoupodlažní stavba, nepodsklepený, bytová jednotka, plochá střecha

Low energy detached house, a two-storey structure, without basement, a dwelling unit, flat roof

### **Bibliographic quotation of vškp**

REITER, Michal. *Low energy detached house*. Brno, 2012. 98 s., 27 s. příl. Bakalářská práce. Vysoké učení technické v Brně, Fakulta stavební, Ústav pozemního stavitelství. Vedoucí práce doc. Ing. Jiří Sedlák, CSc..

**Declaration:**

I declare, that I worked out bachelor thesis alone and that I stated all used information sources.

**Prohlášení:**

Prohlašuji, že jsem bakalářskou práci zpracoval samostatně, a že jsem uvedl všechny použité, informační zdroje.

V Brně dne 25.5.2012  
(In Brno, date)



.....  
podpis autora (signature)

### **Acknowledgements**

I would like to express thanks to supervisor of my bachelor's thesis doc. Ing. Jiří Sedlák, CSc. for proper leading and supervision, patience and helpful advices during consultation.

### **Poděkování:**

Tímto bych rád poděkoval vedoucímu mé bakalářské práce doc. Ing. Jiřímu Sedlákovi, CSc. za jeho vlídně vedení, podporu a cenné připomínky při konzultacích.

## **CONTENTS:**

### **FOLDER A – BASIC DOCUMENTS**

- a) FRONT SHEET
- b) TASK OF THE BACHELOR THESIS
- c) ABSTRACT AND KEYWORDS IN CZECH AND ENGLISH LANGUAGE
- d) BIBLIOGRAPHIC QUOTATION OF VŠKP
- e) DECLARATION OF ORIGINALITY
- f) ACKNOWLEDGEMENT
- g) CONTENTS
- h) INTRODUCTION
- i) LIST OF USED SOURCES AND MATERIALS
- j) LIST OF USED ABBREVIATIONS AND SYMBOLS

ADJUSTED DOCUMENT: POPISNÝ SOUBOR ZÁVĚREČNÉ PRÁCE

### **FOLDER B – STUDIES**

- 1. ACCOMPANYING REPORT
- 2. SITUATION – FURTHER RELATIONS 1:500
- 3. SITUATION 1:200
- 4. DISPOSITION STUDY OF THE FIRST FLOOR 1:100
- 5. DISPOSITION STUDY OF THE SECOND FLOOR 1:100
- 6. SECTION A-A' 1:100
- 7. SECTION B-B' 1:100
- 8. THE NORTH AND THE SOUTH ELEVATIONS 1:100
- 9. THE WEST AND THE EAST ELEVATIONS 1:100



## **FOLDER C1 – PROJECT DRAWINGS**

|   |       |
|---|-------|
| 1. SITUATION – FURTHER RELATIONS                        | 1:500 |
| 2. SITUATION  | 1:200 |
| 3. FLOOR PLAN OF FOUNDATIONS                            | 1:50  |
| 4. FLOOR PLAN OF THE FIRST FLOOR                        | 1:50  |
| 5. FLOOR PLAN OF THE SECOND FLOOR                       | 1:50  |
| 6. SHAPE OF FLOOR CONSTRUCTION ABOVE THE 1st FLOOR      | 1:50  |
| 7. SHAPE OF FLOOR CONSTRUCTION ABOVE THE 2nd FLOOR      | 1:50  |
| 8. ROOF CONSTRUCTION                                    | 1:50  |
| 9. SECTION A-A´   | 1:50  |
| 10. SECTION B-B´  | 1:50  |
| 11. THE NORTH AND THE SOUTH ELEVATIONS                  | 1:100 |
| 12. THE WEST AND THE EAST ELEVATIONS                    | 1:100 |
| 13. DETAIL A – ATTIC                                    | 1:10  |
| 14. DETAIL B – ROOF INLET                               | 1:10  |
| 15. DETAIL C – SOCLE                                    | 1:10  |
| 16. DETAIL D – WINDOW HEAD                              | 1:10  |
| 17. DETAIL E – PASSAGE FOR THE STAIRCASE IN THE CEILING | 1:15  |
| 18. DETAIL F – HIDDEN GIRDER                            | 1:10  |
| 19. LIST OF FLOOR COMPOSITIONS                          |       |
| 20. LIST OF WALL AND ROOF COMPOSITIONS                  |       |
| 21. LIST OF EXTERNAL OPENINGS                           |       |
| 22. LIST OF DOORS                                       |       |
| 23. LIST OF LINELS                                      |       |
| 24. LIST OF LOCKSMITH AND SHEETMETAL COMPONENTS         |       |

## **FOLDER C2 – CALCULATIONS**

1. CALCULATION OF FOUNDATIONS
2. CALCULATION OF STAIRCASE
3. CALCULATION OF HEAT TRANSFER COEFFICIENT

## **FOLDER C3 – REPORTS**

1. ACCOMPANYING REPORT
2. SUMMARY TECHNICAL REPORT
3. TECHNICAL REPORT
4. ENERGY LABEL OF BUILDING ENVELOPE
5. GEOLOGICAL REPORT - SURVEY
6. RADON REPORT – SURVEY

## **FOLDER C4 – FIRE SAFETY**

1. FIRE SAFETY REPORT
2. SITUATION - FIRE PREVENTION DISTANCES 1:200

## **INTRODUCTION**

My bachelor's thesis deals with the construction design of low energy detached house. Object is situated in the city Olomouc-Nová Ulice. Designed building is a two-storey structure without basement. Object is designed with flat roof construction. The aim of my bachelor's thesis is to design energy efficient building. A result of this thesis is modern detached house designed according to the latest requirements for low energy houses.

## **ÚVOD**

Má bakalářská práce se zabývá návrhem výstavby nízkoenergetického rodinného domu. Objekt je situován v Olomouci-městské části Nová Ulice. Navržený dům je dvoupodlažní, nepodsklepený. Střecha je navržena plochá, jednoplášťová. Cílem mé práce je navrhnout energeticky výhodnou stavbu. Výsledkem této práce je moderní rodinný dům, který je navržený podle nejnovějších požadavků na nízkoenergetické rodinné domy.

## LIST OF USED SOURCES:

### **Legislation:**

Act. No. 183/2006 Coll., Building Act

Public Notice 499/2006 Coll., about structure documentation

Public Notice 268/2009 Coll., about technical requirements for constructions

Regulation No. 23/2008 Coll., about technical conditions for fire protection of buildings

Regulation No. 268/2011 Coll., about change of regulation No. 23/2008 Coll.

Regulation No. 246/2011 Coll., about Ministry of Interior determine fire safety conditions and state fire supervision (Regulation about fire prevention)

### **Standards:**

ČSN 73 4301 Residential buildings

ČSN 01 3411 Large scale maps – Drawings and marks

ČSN 01 3420 Construction drawings

ČSN 73 0540-2 Thermal protection of buildings

ČSN EN 1991-1-1 Eurocode 1: Actions on structures

ČSN 73 0810 Fire safety of buildings – General requirements

ČSN 73 0802 Fire safety of buildings – Non-industrial buildings

ČSN 73 0833 Fire safety of buildings – Buildings for dwelling and accommodation

ČSN 73 0873 Fire safety of buildings – Equipment for fire water supply

### **Literature:**

DOSEDĚL, Antonín a kolektiv. *Čítanka výkresů ve stavebnictví*. Sobotáles. Praha, 2004

KLIMEŠOVÁ, Jarmila. *Nauka o pozemních stavbách*. CERM s.r.o. Brno, 2005

KUTNAR, Zdeněk. *Ploché střechy, skladby a detaily*. DEKTRADE a.s., 2011

NEUFERT, Ernest. *Architects' data*. CONSULTINVEST

**Web pages:**

[www.dektrade.cz](http://www.dektrade.cz)

[www.wienerberger.cz](http://www.wienerberger.cz)

[www.sulko.cz](http://www.sulko.cz)

[www.sapeli.cz](http://www.sapeli.cz)

[www.protherm.cz](http://www.protherm.cz)

[www.schiedel.cz](http://www.schiedel.cz)

[www.knauf.cz](http://www.knauf.cz)

[www.weber-terranova.cz](http://www.weber-terranova.cz)

[www.tzb-info.cz](http://www.tzb-info.cz)

[www.cuzk.cz](http://www.cuzk.cz)

[www.geology.cz](http://www.geology.cz)

[www.geofond.cz](http://www.geofond.cz)

## LIST OF USED ABBREVIATIONS AND SYMBOLS

No. – number

Coll. – collection

th. – thickness [mm]

Rdt - bearing capacity of soil [MPa]

$\lambda$  - thermal conductivity [W/m·K]

R - thermal resistance [ $\text{m}^2 \cdot \text{K}/\text{W}$ ]

HT - total heat transmission losses [W/K]

Uem,N - mean required coefficient of heat transfer [ $\text{W}/(\text{m}^2 \cdot \text{K})$ ]

Uem,rec - mean recommended coefficient of heat transfer [ $\text{W}/(\text{m}^2 \cdot \text{K})$ ]

CI – class index

pv - calculated fire load [ $\text{kg} \cdot \text{m}^2$ ]

BPV – height system used in Czech Republic

# PROHLÁŠENÍ O SHODĚ LISTINNÉ A ELEKTRONICKÉ FORMY VŠKP

( DECLARATION OF COMPLIANCE OF PAPER AND  
ELECTRONIC FORM OF VŠKP)

## Declaration:

I declare, that the electronic form of submission is identical with the paper form of submission.

## Prohlášení:

Prohlašuji, že elektronická forma odevzdané práce je shodná s odevzdanou listinnou formou.

V Brně dne 25.5.2012

.....  
  
.....  
podpis autora  
Michal Reiter

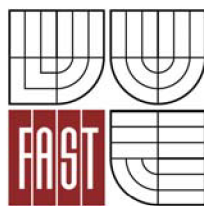

VYSOKÉ UČENÍ TECHNICKÉ V BRNĚ  
FAKULTA STAVEBNÍ

## POPISNÝ SOUBOR ZÁVĚREČNÉ PRÁCE

|   |   |
|---|---|
| <b>Vedoucí práce</b>                    | doc. Ing. Jiří Sedlák, CSc.   |
| <b>Autor práce</b>                      | Michal Reiter   |
| <b>Škola</b>                            | Vysoké učení technické v Brně   |
| <b>Fakulta</b>                          | Stavební  |
| <b>Ústav</b>                            | Ústav pozemního stavitelství  |
| <b>Studijní obor</b>                    | 3608R001 Pozemní stavby   |
| <b>Studijní program</b>                 | B3607 Civil Engineering   |
| <b>Název práce</b>                      | Low energy detached house   |
| <b>Název práce v anglickém jazyce</b>   | Low energy detached house   |
| <b>Typ práce</b>                        | Bakalářská práce  |
| <b>Přidělovaný titul</b>                | Bc.   |
| <b>Jazyk práce</b>                      | Angličtina  |
| <b>Datový formát elektronické verze</b> | PDF   |
| <b>Anotace práce</b>                    | Předmětem mé bakalářské práce je vypracování dokumentace projektu novostavby nízkoenergetického rodinného domu v Olomouci. Objekt je řešen jako dvoupodlažní, nepodsklepená stavba obsahující jednu bytovou jednotku pro čtyřčlennou rodinu. Společně s garáží, která je součástí domu tvoří jeden celek. Střecha je navržena plochá, jednoplášťová. Projektová dokumentace je zpracována dle platných norem.                               |
| <b>Anotace práce v anglickém jazyce</b> | The subject of my bachelor's thesis is elaboration of the project in the level for realization of low energy detached house in Olomouc. Object is designed as a two-storey structure without basement containing a dwelling unit for four member family. Together with garage which is a part of the house forms one whole piece. Structure has a flat roof construction. Project documentation is elaborated according to valid standards. |
| <b>Klíčová slova</b>                    | Nízkoenergetický rodinný dům, dvoupodlažní stavba, nepodsklepený, bytová jednotka, plochá střecha   |
| <b>Klíčová slova v anglickém jazyce</b> | Low energy detached house, a two-storey structure, without basement, a dwelling unit, flat roof   |





**VYSOKÉ UČENÍ TECHNICKÉ V BRNĚ**  
BRNO UNIVERSITY OF TECHNOLOGY

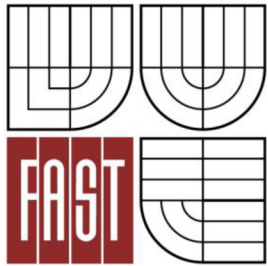

**FAKULTA STAVEBNÍ**  
**ÚSTAV POZEMNÍHO STAVITELSTVÍ**

FACULTY OF CIVIL ENGINEERING  
INSTITUTE OF BUILDING STRUCTURES

## FOLDER C2 – CALCULATIONS

**BAKALÁŘSKÁ PRÁCE**  
BACHELOR'S THESIS

**AUTOR PRÁCE**  
AUTHOR

Michal Reiter

**VEDOUCÍ PRÁCE**  
SUPERVISOR

doc. Ing. JIŘÍ SEDLÁK, CSc.

BRNO 2012

## **FOLDER CONTENT**

1. CALCULATION OF FOUNDATIONS
2. CALCULATION OF STAIRCASE
3. CALCULATION OF HEAT TRANSFER COEFFICIENT

## BACHELOR'S THESIS

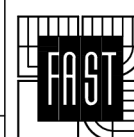

VUT V BRNĚ  
 FAKULTA STAVEBNÍ  
 VEVEŘÍ 331/95  
 602 00 Brno  
 TEL. 541 141 111

DEPARTMENT OF CIVIL ENGINEERING

STUDENT

Michal Reiter

SUP. OF BA. WORK

doc. Ing. Jiří Sedlák, CSc

LOW ENERGY DETACHED HOUSE

FORMAT

A4

DATE

5/2012

CALCULATION OF THE FOUNDATIONS

SCALE

DRAWING N.  
1

**CALCULATION OF THE FOUNDATION STRIPS**

UNDER THE MOST LOADED INTERNAL WALL

**FLAT ROOF+CEILING CONSTRUCTION**

| MATERIAL                                       | HEIGHT(m) | $\gamma$ (kN/m <sup>3</sup> ) | WIDTH(m) | SPAN(m) | FORCE(kN) |
|--|-----------|-------------------------------|----------|---------|-----------|
| WATERPROOF LAYER FROM PVC S PES ALKORPAN 35176 | 0,0015    | 12,450                        | 1,000    | 3,125   | 0,058     |
| SEPARATION LAYER UNWOVEN GEOTEXTILE FILTEK 300 | 0,0045    | 0,660                         | 1,000    | 3,125   | 0,009     |
| THERMAL INSULATION ISOVER EPS 150 S            | 0,200     | 0,280                         | 1,000    | 3,125   | 0,175     |
| VAPOR BARRIER GLASTEK 40 SPECIAL MINERAL       | 0,004     | 0,500                         | 1,000    | 3,125   | 0,006     |
| PERLITCONCRETE                                 | 0,125     | 3,000                         | 1,000    | 3,125   | 1,172     |
| LOADBEARING STRUCTURE FROM POROTHERM CEILING   | 0,250     | 3,420                         | 1,000    | 3,125   | 2,672     |
| PLASTER POROTHERM UNIVERSAL                    | 0,010     | 14,500                        | 1,000    | 3,125   | 0,453     |

$\Sigma=4,55$  kN

**CEILING CONSTRUCTION OVER THE 1ST FLOOR**

| MATERIAL                                       | HEIGHT(m) | $\gamma$ (kN/m <sup>3</sup> ) | WIDTH(m) | SPAN(m) | FORCE(kN) |
|--|-----------|-------------------------------|----------|---------|-----------|
| CERAMIC TILES                                  | 0,009     | 23,000                        | 1,000    | 3,125   | 0,647     |
| GLUE   | 0,005     | 2,000                         | 1,000    | 3,125   | 0,031     |
| ANHYDRIT SCREED CEMEX AnhyLevel 30 (CA-C30-F6) | 0,035     | 21,000                        | 1,000    | 3,125   | 2,297     |
| SEPARATION LAYER PE FOIL                       | 0,001     | 0,500                         | 1,000    | 3,125   | 0,002     |
| ACOUSTIC INSULATION ISOVER N                   | 0,050     | 1,200                         | 1,000    | 3,125   | 0,188     |
| LOADBEARING STRUCTURE FROM POROTHERM CEILING   | 0,250     | 3,420                         | 1,000    | 3,125   | 2,672     |
| PLASTER POROTHERM UNIVERSAL                    | 0,010     | 14,500                        | 1,000    | 3,125   | 0,453     |

$\Sigma=6,29$  kN

**WALL**

| MATERIAL                    | HEIGHT(m) | $\gamma$ (kN/m <sup>3</sup> ) | WIDTH(m) | SPAN(m) | FORCE(kN) |
|-----------------------------|-----------|-------------------------------|----------|---------|-----------|
| PLASTER POROTHERM UNIVERSAL | 5,750     | 14,500                        | 0,010    | 1,000   | 0,834     |
| MASONRY POROTHERM AKU 25    | 5,750     | 9,800                         | 0,250    | 1,000   | 14,088    |
| PLASTER POROTHERM UNIVERSAL | 5,750     | 14,500                        | 0,010    | 1,000   | 0,834     |

$\Sigma=15,76$  kN

$\Sigma=26,59$  kN

+15%

$\Sigma=30,58$  kN

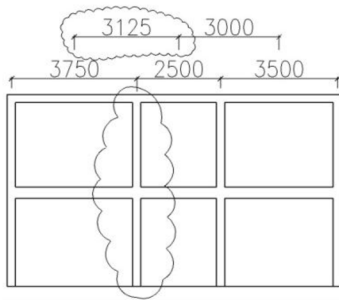

|              |             |                       | SPAN(m) | FORCE(kN) |
|--------------|-------------|-----------------------|---------|-----------|
| IMPOSED LOAD |             | = 1,5kNm <sup>2</sup> | 3,125   | 4,69 kN   |
| SNOW LOAD    | = 0,8*1*1*1 | = 0,8kNm <sup>2</sup> | 3,125   | 2,50 kN   |

**TOTAL SUM OF LOAD**  $F' = 30,58 + 4,69 + 2,50 = \underline{37,77}$  kN

**CALCULATION OF SELF-WEIGHT OF FOUNDATION**

$1,2 * 0,5 * 1 = 0,6 \text{ m}^3 \Rightarrow P = 0,6 * 23 = 11,5$  kN

$F = F' + P = 37,77 + 11,5 = 51,57$  kN

LOAD-BEARING CAPACITY OF SOIL  $R_{dt} = 200$  kPa

$R_{dt} = F / A \dots b = F / R_{dt}$

$b = 51,57 / 200 = 0,26 \text{ m} \Rightarrow 0,5 \text{ m}$

$a = (b - 0,25) / 2 = 0,125 \text{ m}$

$h = a * \text{tg } \alpha = 0,125 * \text{tg } 60^\circ = 0,21 \text{ m}$  TO ENSURE MIN. ANTIFREEZE DEPTH  $\Rightarrow 1,2 \text{ m}$

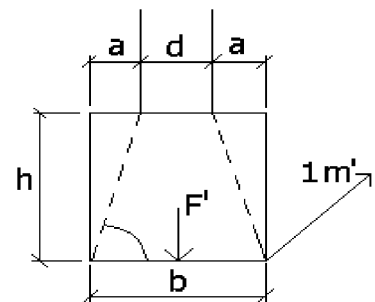

**DESIGN: b = 0,5 m, h = 1,2 m**

**REVIEW:**  $R_{dt} = F / b = 51,57 / 0,5 = 103,14 \text{ kPa} < 200 \text{ kPa}$

-DIMMENSIONS OF THE FOUNDATIONS UNDER THE REST OF THE WALLS WILL BE THE SAME

$\Rightarrow$  **SATISFY**

## BACHELOR'S THESIS

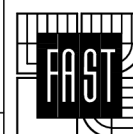

VUT V BRNĚ  
 FAKULTA STAVEBNÍ  
 VEVEŘÍ 331/95  
 602 00 Brno  
 TEL. 541 141 111

DEPARTMENT OF CIVIL ENGINEERING

STUDENT

Michal Reiter

SUP. OF BA. WORK

doc. Ing. Jiří Sedlák, CSc

LOW ENERGY DETACHED HOUSE

FORMAT

A4

DATE

5/2012

CALCULATION OF THE STAIRCASE

SCALE

DRAWING N.  
2

STRAIGHT, ONE FLIGHT INTERIOR STAIRCASE

|                                |   |
|--------------------------------|---|
| CONSTRUCTION HEIGHT            | $h = 3100 \text{ mm}$   |
| PROPOSED HEIGHT OF THE STEP    | $h_{sp} = 175 \text{ mm}$   |
| NUMBER OF STEPS                | $n = h / h_{sp}$<br>$n = 3100/180 = 17,22 \rightarrow 17 \text{ steps}$ |
| DESIGNED HEIGHT OF THE STEP    | $h_s = 3100/17 = 182,3 \text{ mm}$                                      |
| WIDTH OF STEP FROM THE FORMULA | $b = 630 - 2h_s =$<br>$b = 630 - 2 * 182,3 = 265,4 \text{ mm}$          |
| DESIGNED DIMMENSIONS           |   |
| $h_s = 182,3 \text{ mm}$       |   |
| $b = 265,4 \text{ mm}$         |   |
| LENGHT OF THE FLIGHT           | $L = (n - 1) * b$<br>$L = (17 - 1) * 265,4 = 4246 \text{ mm}$           |
| WIDTH OF THE FLIGHT            | $B = 1000 \text{ mm}$   |
| ANGLE OF THE FLIGHT            | $tg \alpha = h / b$<br>$tg \alpha = 182,3/265,4 \rightarrow 34,5^\circ$ |
| PASSAGE HEIGHT                 | $h_1 = 1500 + 750/\cos 34,5^\circ = 2410 \text{ mm}$                    |
| CLEARANCE HEIGHT               | $h_2 = 750 + 1500*\cos 34,5^\circ = 1986 \text{ mm}$                    |

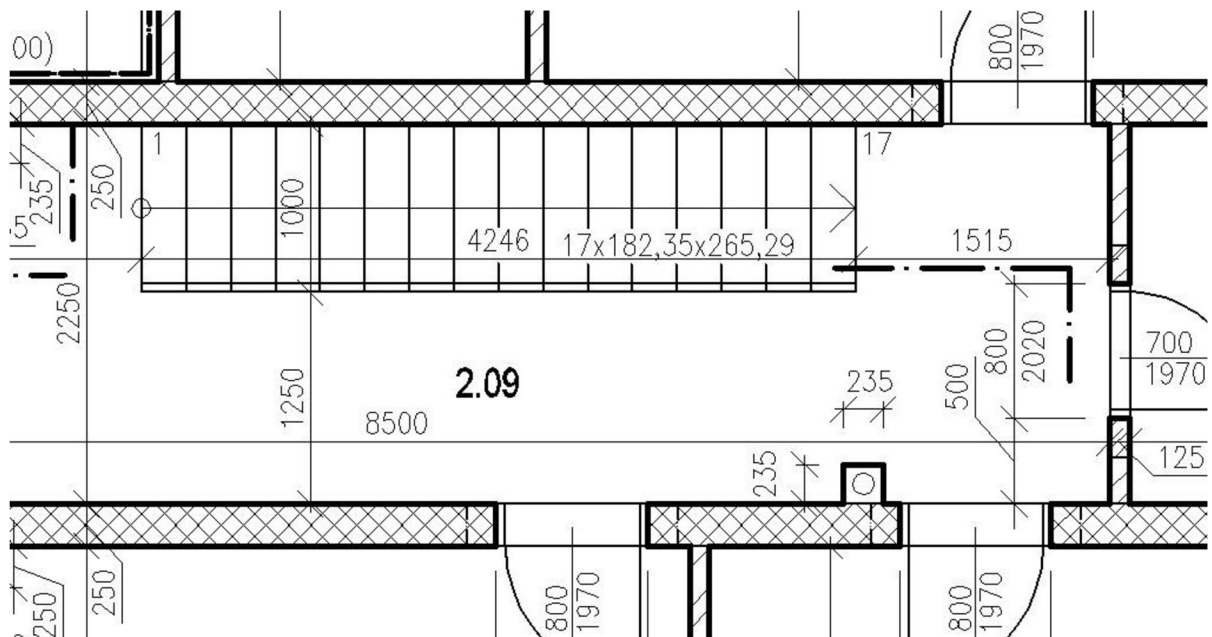

STRAIGHT, ONE FLIGHT EXTERIOR STAIRCASE 1

|                                |   |
|--------------------------------|---|
| CONSTRUCTION HEIGHT            | $h = 300 \text{ mm}$  |
| PROPOSED HEIGHT OF THE STEP    | $h_{sp} = 150 \text{ mm}$   |
| NUMBER OF STEPS                | $n = h / h_{sp}$<br>$n = 300 / 150 = 2 \rightarrow 2 \text{ steps}$ |
| DESIGNED HEIGHT OF THE STEP    | $h_s = 300 / 150 = 150 \text{ mm}$                                  |
| WIDTH OF STEP FROM THE FORMULA | $b = 630 - 2h_s =$<br>$b = 630 - 2 * 150 = 330 \text{ mm}$          |

DESIGNED DIMMENSIONS

$h_s = 150 \text{ mm}$   
 $b = 330 \text{ mm}$

LENGHT OF THE FLIGHT

$L = 660 \text{ mm}$

WIDTH OF THE FLIGHT

$B = 2000 \text{ mm}$

ANGLE OF THE FLIGHT

$\text{tg } \alpha = h / b$

$\text{tg } \alpha = 150 / 330 \rightarrow 24,5^\circ$

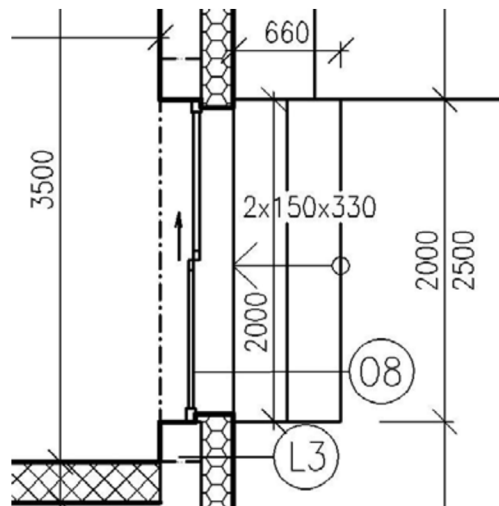

STRAIGHT, ONE FLIGHT EXTERIOR STAIRCASE 2

|                                |   |
|--------------------------------|---|
| CONSTRUCTION HEIGHT            | $h = 300 \text{ mm}$  |
| PROPOSED HEIGHT OF THE STEP    | $h_{sp} = 150 \text{ mm}$   |
| NUMBER OF STEPS                | $n = h / h_{sp}$<br>$n = 300 / 150 = 2 \rightarrow 2 \text{ steps}$ |
| DESIGNED HEIGHT OF THE STEP    | $h_s = 300 / 150 = 150 \text{ mm}$                                  |
| WIDTH OF STEP FROM THE FORMULA | $b = 630 - 2h_s =$<br>$b = 630 - 2 * 150 = 330 \text{ mm}$          |

DESIGNED DIMMENSIONS

$h_s = 150 \text{ mm}$   
 $b = 330 \text{ mm}$

LENGHT OF THE FLIGHT  
WIDTH OF THE FLIGHT  
ANGLE OF THE FLIGHT

$L = 660 \text{ mm}$   
 $B = 2750 \text{ mm}$   
 $\text{tg } a = h / b$   
 $\text{tg } a = 150 / 330 \rightarrow 24,5^\circ$

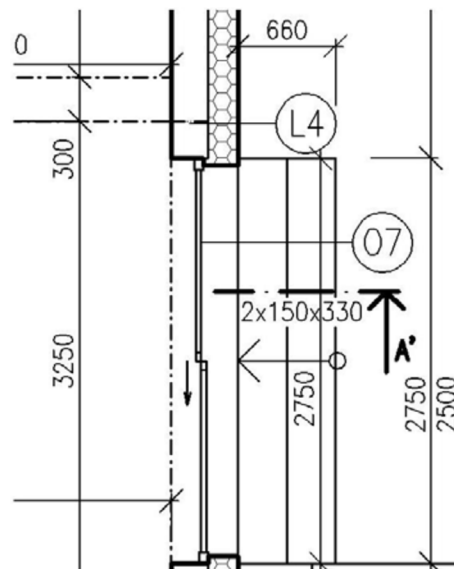



### STRAIGHT, ONE FLIGHT EXTERIOR STAIRCASE 3

|                                |   |
|--------------------------------|---|
| CONSTRUCTION HEIGHT            | $h = 300 \text{ mm}$  |
| PROPOSED HEIGHT OF THE STEP    | $h_{sp} = 150 \text{ mm}$   |
| NUMBER OF STEPS                | $n = h / h_{sp}$<br>$n = 300 / 150 = 2 \rightarrow 2 \text{ steps}$         |
| DESIGNED HEIGHT OF THE STEP    | $h_s = 300 / 150 = 150 \text{ mm}$  |
| WIDTH OF STEP FROM THE FORMULA | $b = 630 - 2h_s =$<br>$b = 630 - 2 * 150 = 330 \text{ mm}$                  |
| DESIGNED DIMMENSIONS           |   |
| $h_s = 150 \text{ mm}$         |   |
| $b = 330 \text{ mm}$           |   |
| LENGHT OF THE FLIGHT           | $L = 660 \text{ mm}$  |
| WIDTH OF THE FLIGHT            | $B = 1000 \text{ mm}$   |
| ANGLE OF THE FLIGHT            | $\text{tg } a = h / b$<br>$\text{tg } a = 150 / 330 \rightarrow 24,5^\circ$ |

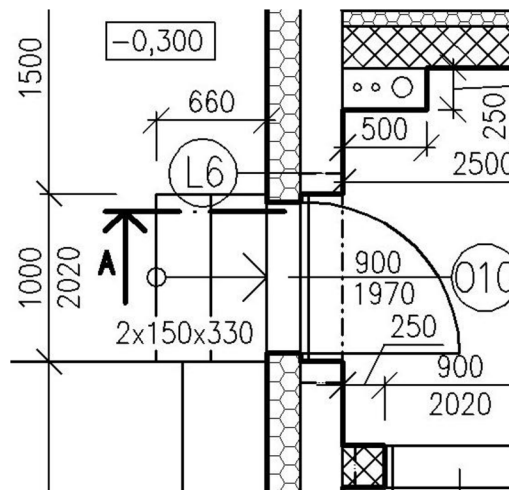

## BACHELOR'S THESIS

STUDENT

Michal Reiter

SUP. OF BA. WORK

doc. Ing. Jiří Sedlák, CSc

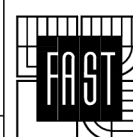

VUT V BRNĚ  
 FAKULTA STAVEBNÍ  
 VEVEŘÍ 331/95  
 602 00 Brno  
 TEL. 541 141 111

DEPARTMENT OF CIVIL ENGINEERING

LOW ENERGY DETACHED HOUSE

FORMAT

A4

DATE

5/2012

CALCULATION OF HEAT TRANSFER COEFFICIENT

SCALE

DRAWING N.  
3

# CALCULATION OF HEAT TRANSFER COEFFICIENT

PAGE 2/6

## 1. STRUCTURE COMPOSITIONS

### A. FLOOR ON THE GROUND WITH CERAMIC TILES

| NO. | MATERIAL                                       | d [m] | $\lambda$ [W/mK] |
|-----|--|-------|------------------|
| 1   | CERAMIC TILES                                  | 0,009 | 1,010            |
| 2   | GLUE   | 0,003 | 1,200            |
| 3   | ANHYDRIT SCREED CEMEX AnhyLevel 30 (CA-C30-F6) | 0,035 | 1,400            |
| 4   | SEPARATION LAYER PE FOIL                       | 0,001 | 0,160            |
| 5   | THERMAL INSULATION ISOVER EPS 150 S            | 0,200 | 0,035            |
| 6   | WATERPROOFING LAYER GLASTEK 40 SPECIAL MINERAL | 0,002 | 0,200            |

### B. FLOOR ON THE GROUND WITH WOODEN FLOORING

| NO. | MATERIAL                                       | d [m] | $\lambda$ [W/mK] |
|-----|--|-------|------------------|
| 1   | WOODEN FLOORING                                | 0,010 | 0,180            |
| 2   | GLUE   | 0,002 | 1,200            |
| 3   | ANHYDRIT SCREED CEMEX AnhyLevel 30 (CA-C30-F6) | 0,035 | 1,400            |
| 4   | SEPARATION LAYER PE FOIL                       | 0,001 | 0,160            |
| 5   | THERMAL INSULATION ISOVER EPS 150 S            | 0,200 | 0,035            |
| 6   | WATERPROOFING LAYER GLASTEK 40 SPECIAL MINERAL | 0,002 | 0,200            |

### C. FLAT ROOF

| NO. | MATERIAL                                       | d [m]  | $\lambda$ [W/mK] |
|-----|--|--------|------------------|
| 1   | WATERPROOF LAYER FROM PVC S PES ALKORPAN 35176 | 0,0015 | 0,200            |
| 2   | SEPARATION LAYER UNWOVEN GEOTEXTILE FILTEK 300 | 0,0045 | 0,200            |
| 3   | THERMAL INSULATION ISOVER EPS 150 S            | 0,200  | 0,035            |
| 4   | VAPOR BARRIER GLASTEK 40 SPECIAL MINERAL       | 0,004  | 0,200            |
| 5   | PERLITCONCRETE                                 | 0,125  | 0,150            |
| 6   | LOADBEARING STRUCTURE FROM POROTHERM CEILING   | 0,250  | 0,290            |
| 7   | PLASTER POROTHERM UNIVERSAL                    | 0,010  | 0,800            |

### D. EXTERNAL WALL

| NO. | MATERIAL                              | d [m] | $\lambda$ [W/mK] |
|-----|---------------------------------------|-------|------------------|
| 1   | SILICATE PLASTER-THIN LAYER FOR ETICS | 0,002 | 0,800            |
| 2   | THERMAL INSULATION ISOVER EPS 70 F    | 0,200 | 0,038            |
| 3   | MASONRY POROTHERM PROFI 24            | 0,240 | 0,280            |
| 4   | PLASTER POROTHERM UNIVERSAL           | 0,010 | 0,800            |

### E. INTERNAL WALL BETWEEN GARAGE AND HALL

| NO. | MATERIAL                           | d [m] | $\lambda$ [W/mK] |
|-----|------------------------------------|-------|------------------|
| 1   | PLASTER POROTHERM UNIVERSAL        | 0,010 | 0,800            |
| 2   | MASONRY POROTHERM AKU 25           | 0,250 | 0,710            |
| 3   | THERMAL INSULATION ISOVER EPS 70 F | 0,100 | 0,038            |
| 4   | PLASTER POROTHERM UNIVERSAL        | 0,010 | 0,800            |

# CALCULATION OF HEAT TRANSFER COEFFICIENT

PAGE 3/6

## F. CEILING BETWEEN GARAGE AND BATHROOM

| NO. | MATERIAL                                       | d [m] | $\lambda$ [W/mK] |
|-----|--|-------|------------------|
| 1   | CERAMIC TILES                                  | 0,009 | 1,010            |
| 2   | GLUE   | 0,005 | 1,200            |
| 3   | ANHYDRIT SCREED CEMEX AnhyLevel 30 (CA-C30-F6) | 0,035 | 1,400            |
| 4   | SEPARATION LAYER PE FOIL                       | 0,001 | 0,160            |
| 5   | ACOUSTIC INSULATION ISOVER N                   | 0,050 | 0,036            |
| 6   | LOADBEARING STRUCTURE FROM POROTHERM CEILING   | 0,250 | 0,290            |
| 7   | THERMAL INSULATION ISOVER EPS 70F              | 0,100 | 0,038            |
| 8   | PLASTER POROTHERM UNIVERSAL                    | 0,010 | 0,800            |

## 2. THERMAL RESISTANCE CALCULATION

THERMAL RESISTANCE: A MEASURE OF BODY ABILITY TO PREVENT HEAT FROM FLOWING THROUGH IT

CALCULATION:

$$R_t = R_i + \sum R_j + R_e$$

[m<sup>2</sup>K/W]

$$R_j = d / \lambda$$

..... RESISTANCE OF LAYER

d

..... WIDTH OF LAYER

$\lambda$

..... COEFFICIENT OF THERMAL CONDUCTIVITY OF MATERIAL [W/mK]

$R_{si}$

..... RESISTANCE OF INTERNAL SURFACE

$R_{se}$

..... RESISTANCE OF EXTERNAL SURFACE

### A. FLOOR ON THE GROUND WITH CERAMIC TILES

| $R_j$ | d     | / | $\lambda$ | = | [m <sup>2</sup> K/W] |
|-------|-------|---|-----------|---|----------------------|
| R1    | 0,009 | / | 1,010     | = | 0,009                |
| R2    | 0,003 | / | 1,200     | = | 0,003                |
| R3    | 0,035 | / | 1,400     | = | 0,025                |
| R4    | 0,001 | / | 0,160     | = | 0,006                |
| R5    | 0,200 | / | 0,035     | = | 5,714                |
| R6    | 0,002 | / | 0,200     | = | 0,010                |

$$R_{si} = 0,17 \quad \text{m}^2\text{K/W} \quad (\text{FOR DOWNWARD VERTICAL DIRECTION OF FLOW})$$

$$R_t = R_{si} + \sum R_j = 5,937 \quad \text{m}^2\text{K/W}$$

### B. FLOOR ON THE GROUND WITH WOODEN FLOORING

| $R_j$ | d     | / | $\lambda$ | = | [m <sup>2</sup> K/W] |
|-------|-------|---|-----------|---|----------------------|
| R1    | 0,010 | / | 0,180     | = | 0,056                |
| R2    | 0,002 | / | 1,200     | = | 0,002                |
| R3    | 0,035 | / | 1,400     | = | 0,025                |
| R4    | 0,001 | / | 0,160     | = | 0,006                |
| R5    | 0,200 | / | 0,035     | = | 5,714                |
| R6    | 0,002 | / | 0,200     | = | 0,010                |

# CALCULATION OF HEAT TRANSFER COEFFICIENT

PAGE 4/6

$$R_{si} = 0,17 \quad \text{m}^2\text{K/W} \quad (\text{FOR DOWNWARD VERTICAL DIRECTION OF FLOW})$$

$$R_t = R_{si} + \sum R_j = 5,983 \quad \text{m}^2\text{K/W}$$

## C. FLAT ROOF

| $R_j$ | d      | / | $\lambda$ | = | $[\text{m}^2\text{K/W}]$ |
|-------|--------|---|-----------|---|--------------------------|
| R1    | 0,0015 | / | 0,200     | = | 0,008                    |
| R2    | 0,0045 | / | 0,200     | = | 0,023                    |
| R3    | 0,200  | / | 0,035     | = | 5,714                    |
| R4    | 0,004  | / | 0,200     | = | 0,020                    |
| R5    | 0,125  | / | 0,150     | = | 0,833                    |
| R6    | 0,250  | / | 0,290     | = | 0,862                    |
| R7    | 0,010  | / | 0,800     | = | 0,013                    |

$$R_{si} = 0,10 \quad \text{m}^2\text{K/W} \quad (\text{FOR UPWARD VERTICAL DIRECTION OF FLOW})$$

$$R_{se} = 0,04 \quad \text{m}^2\text{K/W} \quad (\text{FOR WINTER SEASON})$$

$$R_t = R_{si} + \sum R_j + R_{se} = 7,612 \quad \text{m}^2\text{K/W}$$

## D. EXTERNAL WALL

| $R_j$ | d     | / | $\lambda$ | = | $[\text{m}^2\text{K/W}]$ |
|-------|-------|---|-----------|---|--------------------------|
| R1    | 0,002 | / | 0,800     | = | 0,003                    |
| R2    | 0,200 | / | 0,038     | = | 5,263                    |
| R3    | 0,240 | / | 0,280     | = | 0,857                    |
| R4    | 0,010 | / | 0,800     | = | 0,013                    |

$$R_{si} = 0,13 \quad \text{m}^2\text{K/W} \quad (\text{FOR HORIZONTAL DIRECTION OF FLOW})$$

$$R_{se} = 0,04 \quad \text{m}^2\text{K/W} \quad (\text{FOR WINTER SEASON})$$

$$R_t = R_{si} + \sum R_j + R_{se} = 6,305 \quad \text{m}^2\text{K/W}$$

## E. INTERNAL WALL BETWEEN GARAGE AND HALL

| $R_j$ | d     | / | $\lambda$ | = | $[\text{m}^2\text{K/W}]$ |
|-------|-------|---|-----------|---|--------------------------|
| R1    | 0,010 | / | 0,010     | = | 0,800                    |
| R2    | 0,100 | / | 0,250     | = | 0,710                    |
| R3    | 0,250 | / | 0,100     | = | 0,038                    |
| R4    | 0,010 | / | 0,010     | = | 0,800                    |

$$R_{si} = 0,13 \quad \text{m}^2\text{K/W} \quad (\text{FOR HORIZONTAL DIRECTION OF FLOW})$$

$$R_t = R_{si} + \sum R_j = 2,478 \quad \text{m}^2\text{K/W}$$

# CALCULATION OF HEAT TRANSFER COEFFICIENT

PAGE 5/6

## F. CEILING BETWEEN GARAGE AND BATHROOM

| $R_j$ | d     | / | $\lambda$ | = | $[m^2K/W]$ |
|-------|-------|---|-----------|---|------------|
| R1    | 0,009 | / | 1,010     | = | 0,009      |
| R2    | 0,005 | / | 1,200     | = | 0,004      |
| R3    | 0,035 | / | 1,400     | = | 0,025      |
| R4    | 0,001 | / | 0,160     | = | 0,006      |
| R5    | 0,050 | / | 0,036     | = | 1,389      |
| R6    | 0,250 | / | 0,290     | = | 0,862      |
| R7    | 0,100 | / | 0,038     | = | 2,632      |
| R8    | 0,010 | / | 0,800     | = | 0,013      |

$$R_{si} = 0,17 \quad m^2K/W \quad (\text{FOR DOWNWARD VERTICAL DIRECTION OF FLOW})$$

$$R_t = R_{si} + \sum R_j = 5,109 \quad m^2K/W$$

## 3. HEAT TRANSFER COEFFICIENT CALCULATION

HEAT TRANSFER COEFFICIENT: REPRESENTS THE OVERALL HEAT EXCHANGE BETWEEN SPACES SEPARATED BY GIVEN STRUCTURE

CALCULATION:  
 $U = 1/R_t \quad [W/m^2K]$

### A. FLOOR ON THE GROUND WITH CERAMIC TILES

$$U = 1/5,937 = 0,168 \quad [W/m^2K]$$

### B. FLOOR ON THE GROUND WITH WOODEN FLOORING

$$U = 1/5,983 = 0,167 \quad [W/m^2K]$$

### C. FLAT ROOF

$$U = 1/7,612 = 0,131 \quad [W/m^2K]$$

### D. EXTERNAL WALL

$$U = 1/6,305 = 0,159 \quad [W/m^2K]$$

### E. INTERNAL WALL BETWEEN GARAGE AND HALL

$$U = 1/2,478 = 0,404 \quad [W/m^2K]$$

### F. CEILING BETWEEN GARAGE AND BATHROOM

$$U = 1/5,109 = 0,196 \quad [W/m^2K]$$

# CALCULATION OF HEAT TRANSFER COEFFICIENT

PAGE 6/6

## 4.HEAT TRANSFER COEFFICIENT REQUIRED AND RECCOMENDED VALUES

| STRUCTURE  | REQUIRED<br>(RECCOMENDED) | CALCULATED | RESULT    |
|--|---------------------------|------------|-----------|
| FLOOR ON THE GROUND  | 0,45(0,30)                | 0,17       | SATISFIED |
| FLAT ROOF  | 0,24 (0,16)               | 0,13       | SATISFIED |
| EXTERNAL WALL  | 0,30(0,25)                | 0,16       | SATISFIED |
| FLOOR FROM THE INTERNAL HEATED SPACE TO THE UNHEATED SPACE | 0,60 (0,40)               | 0,20       | SATISFIED |
| WALL FROM THE INTERNAL HEATED SPACE TO THE UNHEATED SPACE  | 0,60 (0,40)               | 0,40       | SATISFIED |
| WINDOWS  | 1,50(1,20)                | 0,7        | SATISFIED |



**VYSOKÉ UČENÍ TECHNICKÉ V BRNĚ**  
BRNO UNIVERSITY OF TECHNOLOGY

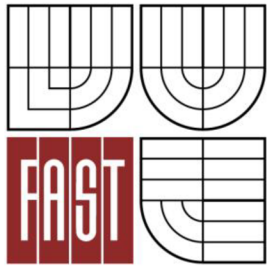

**FAKULTA STAVEBNÍ**  
**ÚSTAV POZEMNÍHO STAVITELSTVÍ**

FACULTY OF CIVIL ENGINEERING  
INSTITUTE OF BUILDING STRUCTURES

## FOLDER C3 – REPORTS

**BAKALÁŘSKÁ PRÁCE**  
BACHELOR'S THESIS

**AUTOR PRÁCE**  
AUTHOR

Michal Reiter

**VEDOUCÍ PRÁCE**  
SUPERVISOR

doc. Ing. JIŘÍ SEDLÁK, CSc.



## **FOLDER CONTENT**

1. ACCOMPANYING REPORT
2. SUMMARY TECHNICAL REPORT
3. TECHNICAL REPORT
4. ENERGY LABEL OF BUILDING ENVELOPE
5. GEOLOGICAL REPORT - SURVEY
6. RADON REPORT – SURVEY

## BACHELOR'S THESIS

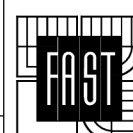

VUT V BRNĚ  
 FAKULTA STAVEBNÍ  
 VEVEŘÍ 331/95  
 602 00 Brno  
 TEL. 541 141 111

DEPARTMENT OF CIVIL ENGINEERING

STUDENT

Michal Reiter

SUP. OF BA. WORK

doc. Ing. Jiří Sedlák, CSc

LOW ENERGY DETACHED HOUSE

FORMAT

A4

DATE

5/2012

ACCOMPANYING REPORT

SCALE

DRAWING N.  
1

## **a) Identification data**

### Name of the building object:

Low energy detached house in Zirmova street

### Place of the building object:

City: Olomouc

Street: Zirmova

Cadastral area: Nová Ulice (district Olomouc); 710717

Plot number: 153/29

### Investor:

Name: Jan Novák

Address: Polívková 14  
77900, Olomouc

### Designer:

Name: Michal Reiter

Address: Mošnerova 17  
77900, Olomouc

## **Basic description**

Building is a two storey detached house without basement, with garage for one car which is a part of the house. Object is placed on a plot no. 153/29 of the cadastral area Nová Ulice (district Olomouc). Building consists of one flat 6+1. Paved areas, fencing, service connections (water, sewer, gas, electricity) will be part of building works.

## **b) Data concerning present use and urbanization of territory, proprietary legal relation**

Building site is located on the building plot in the south-west area of the city Olomouc. In the past there were barracks and other military buildings which were demolished with a view to build new housing areas. Nowadays is parcel no. 153/29 without any usage, in Town and country plan is parcel noted as a parcel for living in the family houses. Plot has a rectangular shape; on the north-west side is local road. Along the remaining sides are neighboring building plots. Main service networks lead under the roadway and in the two meters width strip along the roadway. Building site terrain is modified and leveled to the plane. Plot is accessible from an existing roadway.

Proprietary legal relation: investor is the owner of the plot.

## **c) Information about surveys performed, dates of approach to routes and to technical infrastructure**

#### Surveys performed

- Engineering geological study
- Radon survey

#### Approach to routes

Approach of designed construction of family house to public communication is from the existing street Zirmova

#### Approach to the technical infrastructure

Building will be connected to the public systems which are at the edge of the plot.

- Low voltage electricity distribution network
- Water main
- Sewerage
- Low-pressure gas pipeline

#### **d) Information about the fulfillment of concerned authorities requirements**

The project documentation is prepared in accordance with all concerned state authorities and other concerned organizations.

#### **e) Information on compliance of general requirements for construction**

The building documentation is prepared in accordance with public notice no. 501/2006 Coll. about general requirements about usage of area. The documentation is compliant with public notice no. 137/1998 Coll. about technical requirements for building works.

#### **f) Data of fulfillment of land use approval, regulatory plan**

The building is fully complying with the land use approval and regulatory plan.

#### **g) Subject and linkage on related and conditioning constructions and the other disposals in the touched zone**

In the area are finished public roadways and technical service lines so building works can start immediately after completion of building administration.

Object has no direct connection to surrounding buildings. Investor will consult the project with owners of closed plots before start of the project realization.

#### **h) Supposed time-limit of construction including description of construction progress**

Building works are supposed to start at July 2012, building is supposed to be completed in October 2013.

Description of building processes:

- Rough terrain and digging work

- Digging of foundations
- Concreting of foundations
- Connections of public networks
- Waterproofing
- Vertical load-bearing constructions
- Horizontal load-bearing constructions
- Roof construction
- Roofing
- Entrance doors, windows
- Thermal insulation
- Surface finishing
- Finishing works
- Take over

**i) Statistical data about supposed price and surface areas:**

Supposed price

Supposed price is calculated by estimation of a unit price of cubic meter of building. In the reality it can be different.

|                                 |                       |
|---------------------------------|-----------------------|
| Enclosed space:                 | 789,75 m <sup>3</sup> |
| Unit price per m <sup>3</sup> : | 5 000 CZK             |
| Supposed price of the building: | 3 948 750 CZK         |

|                              |                       |
|------------------------------|-----------------------|
| Plot area:                   | 998,30 m <sup>2</sup> |
| Paved area:                  | 75,00 m <sup>2</sup>  |
| Built up area:               | 126,36 m <sup>2</sup> |
| Floor area of the building:  | 213,75 m <sup>2</sup> |
| Enclosed space:              | 789,75 m <sup>3</sup> |
| Number of flats:             | 1                     |
| Assumed number of residents: | 4                     |

## BACHELOR'S THESIS

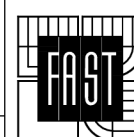

VUT V BRNĚ  
 FAKULTA STAVEBNÍ  
 VEVEŘÍ 331/95  
 602 00 Brno  
 TEL. 541 141 111

DEPARTMENT OF CIVIL ENGINEERING

STUDENT

Michal Reiter

SUP. OF BA. WORK

doc. Ing. Jiří Sedlák, CSc

LOW ENERGY DETACHED HOUSE

FORMAT

A4

DATE

5/2012

SUMMARY TECHNICAL REPORT

SCALE

DRAWING N.  
2

## **1. Identification data**

### Name of the building object:

Low energy detached house in Zirmova street

### Place of the building object:

City: Olomouc

Street: Zirmova

Cadastral area: Nová Ulice (district Olomouc);710717

Plot number: 153/29

### Investor:

Name: Jan Novák

Address: Polívková 14  
77900, Olomouc

### Designer:

Name: Michal Reiter

Address: Mošnerova 17  
77900, Olomouc

## **2. Urban, architectural and construction engineering solution**

### **a) Evaluation of building site**

Building site is located on the building plot in the south-west area of the city Olomouc. Building site is appropriate for the object of detached house. Plot has a rectangular shape, on the north-west side is local road. Along the remaining sides are neighboring building plots. Main service networks lead under the roadway and in the two meters width strip along the roadway. Building site terrain is modified and leveled to the plane. The house will be accessible from an existing roadway by new paved walk-in and drive-in entrance. Living space will be opened to the south into the garden.

### **b) Urban and architectural solution**

Building has a rectangular layout. It is a two storey house without basement and with flat roof. The architectural expression of the object is designed to correspond with the surrounding buildings, it is adapted to the conditions of given area and respect needs on utilization of building and demands on the low energy house. Layout dimensions are 12,15 m x 10,4 m. Height of the building is 6,85 m.

Basic functional parts of the building are connected to the central hall with staircase. First part includes vestibule, garage, and storage of sport and garden equipment, toilet and technical room with laundry. Main living space is in the south-east part, it includes living room, dining room and kitchen with pantry. Kitchen and dining room are divided by partition with free

walkway through simple opening. Living room is oriented to the garden and directly connected to the dining room. Last part is the second floor accessible by one flight staircase from the hall. In the second floor is situated one master bedroom for parents with own dress room, two bedrooms for children, study room, bathroom, toilet and a small storage room. All rooms in the family house are designed with maximum functionality according to the investor requirements.

Structural system of the walls is blockwork with ceilings from prefab ceramic blocks and beams. House is founded on foundation strips in an antifreeze depth. External load-bearing walls are made of ceramic blocks on full area glue, thickness of the blocks is 240 mm, internal walls are from ceramic blocks on mortar, thickness of the block is 250 mm. Over the openings will be ceramic lintels. External walls will be insulated by polystyrene boards of the thickness 200 mm. Partitions walls are made of ceramic AKU blocks of the thickness 115 mm. Ceilings above the first floor and under the flat roof are made from prefab ceramic blocks and beams. As a thermal insulation of flat roof is used EPS polystyrene of the thickness 200 mm. Sloping is made of the lightweight concrete. As a waterproofing layer will be used PCV foil ALKORPAN 35176. In front of the living room will be terrace made of WPC material on leveling pedestals. Fencing will be made of steel columns with wire panels. Family house will be connected to the public service lines, water supply pipe, sewerage system, electricity and gas. All public service lines are already prepared on the boarder of site. Heating of family house is designed by central heating, as a heat source will be condensing gas boiler with accumulating tank placed in technical room.

Statistical data:

|                             |                       |
|-----------------------------|-----------------------|
| Plot area:                  | 998,30 m <sup>2</sup> |
| Paved area:                 | 75,00 m <sup>2</sup>  |
| Built up area:              | 126,36 m <sup>2</sup> |
| Floor area of the building: | 213,75 m <sup>2</sup> |
| Enclosed space:             | 789,75 m <sup>3</sup> |
| Number of flats:            | 1                     |
| Number of residents:        | 4                     |

## **2. Mechanical endurance and stability**

The building is designed so that the load acting on it during the construction and use should not result in:

- a) Collapse of building or part of the building
- b) Inadmissible degree of deformation of structure
- c) Damage to other parts of building or installations or equipment as a result of bigger deformation of load-bearing construction

Detailed solution of the constructions is described in the technical report. Static calculations are done by authorized static engineer and it is a separate part of the project. Construction works will be done according this project and static assessment. All products used in construction will fulfill relevant standards, technical data sheets will be submitted for final building approval.



### **3. Fire safety**

Fire solution is processed by authorized engineer and is a separate part of the project documentation. Each structural part designed according to this solution.

### **4. Environment protection**

Building and its use will not have a negative impact on the surrounding environment. During the use of building will be produced only municipal waste which will be deposited in containers on given place and taken out by the authorized company.

During construction will be respected all rules of hygiene regulations, particularly noise and dust production. The proposed technology does not arise any hazardous waste during the construction works.

Due to the characteristics of the building and its location, it won't have a negative impact on flora, fauna and ecosystems in the area won't affect any architectural or archaeological monuments or protected parts of the nature.

With produced wastes will be handled in accordance with applicable public requirements and to the eventual use or destruction will be transmitted only to authorized persons within the meaning of Act. 185/2001 Coll. about waste.

There will be made a register of produced wastes in accordance with public notice 383/2001 Coll. about details of handling with waste.

### **5. Safety during usage**

General rules are applied during the utilization. Project documentation is designed in accordance with public notice no. 137/1998 Coll. about general technical requirements for building and amended by public notice 502/2006 Coll.

### **6. Hygiene and health protection**

Project documentation is designed in accordance with public notice no. 20/2006 Coll. about care about people's health.

Waterproofing layer on the ground has sufficient properties to protect inhabitants against radon influence.

Lightning of living space is sufficient by natural light through the windows. Lightning and insulating fulfills requirements of standards CSN 734301 and CSN 730590.

The ventilation will be handled manually (through the windows and doors). Kitchen is equipped with fume hood with carbon filters ensuring of absorbing odors.

### **7. Noise protection**

Project documentation is designed in accordance with public notice no. 148/2006 Coll. about health protection against unfavorable actions of noise and vibration. All installations will be properly insulated. Risers of sewerage will be covered by mineral wool for sound absorption as well as downleads from the roof. Inner walls satisfy requirements for acoustics (related to their type of usage). External walls satisfy limits for airborne sound penetration. The surrounding area is planned to be used for living, no sources of extensive noise are known or planned.

## **8. Energy saving and protection against heat losses**

Project documentation is designed in accordance with law no. 406/2006 Coll. about handling with energy. Energy performance certificate is separate part of building documentation.

## **9. Use of building for men with reduced ability of movement and orientation**

Project documentation is designed in accordance with law no. 183/2006 Coll. Building law and public notice 369/2001 Coll. about general requirements for use of buildings by man with reduced ability of movement and orientation.

## **10. Protection of the building against detrimental environmental effects**

According to the information from radon maps, there is a low radon index related to this building site; the building doesn't need to have additional radon insulation-waterproofing layer (Glastek 40 special mineral) is sufficient for radon protection of the building. Building does not need any protection against aggressive ground water, seismicity or undermining.

## **11. Protection of population**

Building satisfies requirements stated in standards and does not require any additional protective solution.

## **12. Engineering of networks**

Building will be connected to the public water supply pipeline, sewerage pipeline, low voltage electricity cable and low pressure gas pipeline. Which are located on the borders of the plot.

## **13. Traffic solution**

Building will be connected to the existing road.

## **14. Production and non-production technological building appliances**

They are not present in the building it is not use for any kind of production.

## BACHELOR'S THESIS

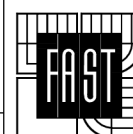

VUT V BRNĚ  
 FAKULTA STAVEBNÍ  
 VEVEŘÍ 331/95  
 602 00 Brno  
 TEL. 541 141 111

DEPARTMENT OF CIVIL ENGINEERING

STUDENT

Michal Reiter

SUP. OF BA. WORK

doc. Ing. Jiří Sedlák, CSc

LOW ENERGY DETACHED HOUSE

FORMAT

A4

DATE

5/2012

TECHNICAL REPORT

SCALE

DRAWING N.  
3

## **1. Identification data**

### Name of the building object:

Low energy detached house in Zirmova street

### Place of the building object:

City: Olomouc

Street: Zirmova

Cadastral area: Nová Ulice (district Olomouc);710717

Plot number: 153/29

### Investor:

Name: Jan Novák

Address: Polívkova 14  
77900, Olomouc

### Designer:

Name: Michal Reiter

Address: Mošnerova 17  
77900, Olomouc

## **2. Object purpose**

Subject of project documentation is a new family house. Object will be used for permanent living of family with 4 members.

## **3. Urban, architectural and construction engineering solution**

### **a) Evaluation of building site**

Building site is located on the building plot in the south-west area of the city Olomouc. Building site is appropriate for the object of detached house. Plot has a rectangular shape, on the north-west side is local road. Along the remaining sides are neighboring building plots. Main service networks lead under the roadway and in the two meters width strip along the roadway. Building site terrain is modified and leveled to the plane. The house will be accessible from an existing roadway by new paved walk-in and drive-in entrance. Living space will be opened to the south into the garden.

### **b) Urban and architectural solution**

Building has a rectangular layout. It is a two storey house without basement and with flat roof. The architectural expression of the object is designed to correspond with the surrounding buildings, it is adapted to the conditions of given area and respect needs on utilization of

building and demands on the low energy house. Layout dimensions are 12,15 m x 10,4 m. Height of the building is 6,85 m.

#### Disposition:

Basic functional parts of the building are connected to the central hall with staircase. First part includes vestibule, garage, and storage of sport and garden equipment, toilet and technical room with laundry. Main living space is in the south-east part, it includes living room, dining room and kitchen with pantry. Kitchen and dining room are divided by partition with free walkway through simple opening. Living room is oriented to the garden and directly connected to the dining room. Last part is the second floor accessible by one flight staircase from the hall. In the second floor is situated one master bedroom for parents with own dress room, two bedrooms for children, study room, bathroom, toilet and a small storage room. All rooms in the family house are designed with maximum functionality according to the investor requirements.

#### Technical solution:

Structural system of the walls is blockwork with ceilings from prefab ceramic blocks and beams. House is founded on foundation strips in an antifreeze depth. External load-bearing walls are made of ceramic blocks on full area glue, thickness of the blocks is 240 mm, internal walls are from ceramic blocks on mortar, thickness of the block is 250 mm. Over the openings will be ceramic lintels. External walls will be insulated by polystyrene boards of the thickness 200 mm. Partitions walls are made of ceramic AKU blocks of the thickness 115 mm. Ceilings above the first floor and under the flat roof are made from prefab ceramic blocks and beams. As a thermal insulation of flat roof is used EPS polystyrene of the thickness 200 mm. Sloping is made of the lightweight concrete. As a waterproofing layer will be used PCV foil ALKORPAN 35176. In front of the living room will be terrace made of WPC material on leveling pedestals. Fencing will be made of steel columns with wire panels. Family house will be connected to the public service lines, water supply pipe, sewerage system, electricity and gas. All public service lines are already prepared on the boarder of site. Heating of family house is designed by central heating, as a heat source will be condensing gas boiler with accumulating tank placed in technical room.

#### Statistical data:

|                             |                       |
|-----------------------------|-----------------------|
| Plot area:                  | 998,30 m <sup>2</sup> |
| Paved area:                 | 75,00 m <sup>2</sup>  |
| Built up area:              | 126,36 m <sup>2</sup> |
| Floor area of the building: | 213,75 m <sup>2</sup> |
| Enclosed space:             | 789,75 m <sup>3</sup> |
| Number of flats:            | 1                     |
| Number of residents:        | 4                     |

### **c) Detailed technical solution**

#### **c.1. Demolitions, cleaning works**

Construction does not include.

#### **c.2. Excavations, ground works**

Before starting of excavation work the building object will be placed according the situation plan and with on site measurement will be set up height level of the building. Family house will be fitted in the terrain with respect to the height of surrounding road. Excavated soil will be transported to the repository and later will be used for covering and terrain modifications. The captured topsoil of thickness approximately 200 mm will be after the completion of construction works spread on the land. Excavations of foundation strips will be made mechanically with a manual cleaning. Maximum allowed degree of the slope is 65 degrees- this valid for the argillaceous soil which was evaluated by the geotechnical report. Foundation pits will be secured against back falling of the ground. Requirements about protection of foundation pits against action of unfavorable weather conditions must be fulfilled; conditions are given by CSN 731001. Shape and placing of the excavations is taken from the drawings. Upon overtaking of the foundation strips is necessary supervision of the building designer. Supervision of strength and depth of foundation must be proceed and noted into the building diary. Adjustment of the ground surface will be done mechanically. Infill and embankments must be properly compacted.

### **c.3. Foundations**

All load-bearing walls are founded on the foundation strips made from the concrete C16/20. Depth of the strips must be sufficient to the antifreeze depth in order to achieve sufficient bearing conditions. Dimensions are designed according to the enclosed calculations. Foundation slab of the thickness 150 mm is done under the whole object; it is reinforced by Ø6 mm steel KARI mesh 150x150 mm which is laid near to the bottom of the slab. Foundations have protection against radon by waterproofing layer Glasstek 40 Special which is sufficient for the low radon index degree which was evaluated in the radon report. Foundation strips are insulated by Isover EPS perimeter of the thickness 120 mm.

### **c.4. Vertical load bearing constructions**

Perimeter load-bearing walls of the thickness 240 mm are from the blocks Porotherm 24 Profi on the mortar Porotherm Profi for thin joints. The inner load-bearing walls of the thickness 250 mm are made from blocks Porotherm 25 AKU on mortar Porotherm th. 12 mm. External walls are isolated by polystyrene Isover EPS 70 F-ETICS system of the thickness 200 mm. On the internal sides of the walls will be used plaster Porotherm universal of the thickness 10 mm. Chimney Schiedel Absolut is designed for outlet of fouling from condensing gas boiler. Condensed water will be drained into sewerage system. Technological solution and processing is given by manufacturer and it must be respected.

### **c.5. Partitions**

Partitions of the thickness 115 mm are designed from blocks Porotherm 11,5 AKU on the mortar Porotherm th. 12 mm.

### **c.6. Horizontal constructions**

Lintels in the external walls are made from combination ceramic Porotherm lintel 7 and Porotherm Vario lintel. Lintels in the internal load bearing walls are from

Porotherm lintels 7 and in the partitions from the Porotherm lintels 11,5. Bedding and combinations of the lintels are specified in the list of lintels which is in the enclosure. The ceiling construction of the thickness 250 mm is designed as prefab MIAKO 19/625(500) fittings and POT 17,5 beams of POROTHERM system, with spreading concrete slab of the thickness 60 mm. The whole ceiling slab will be reinforced by steel mesh Ø6/150/150 mm, concrete C16/20. The inspection of the reinforcement and penetration holes will be done by the static engineer or designer before the casting of the ceiling. There will be made a record to the building log about the overtaking of the ceiling construction. All penetration holes are marked in the individual drawings of the ceilings.

#### **c.7. Concrete rings**

Concrete rings are dimensioned in the scope of ceiling construction. Their dimensions can be found in the drawings of the ceiling construction.

#### **c.8. Roof construction**

The roof construction above the second floor is designed as prefab MIAKO 19/625(500) fittings and POT 17,5 beams of POROTHERM system, with spreading concrete slab of the thickness 60 mm. The whole ceiling slab will be reinforced by steel mesh Ø6/150/150 mm, concrete C16/20. Sloping is made from lightweight concrete. Thermal insulation is assured by polystyrene Isover EPS 150 S Stabil of the thickness 200 mm laid in two layers by 100 mm with overlapping of their joints. Waterproofing layer is from PVC foil S PES ALKORPAN 35176 of the thickness 1,5 mm. Shape of the roof is given by drawing. Drainage of the rain water will be done by two internal downleads.

#### **c.9. Staircase**

The staircase is straight, one flight, designed from monolithic reinforced concrete with handrails to the height of 1000 mm. Staircase is bedded on the foundation strip in the 1st floor and on the load-bearing wall in the 2nd floor.

#### **c.10. Finishing of surfaces and flooring**

External facade is finished by WEBER silicate plaster color and type will be chosen by investor. Interior plasters are from POROTHERM UNIVERSAL plaster of the thickness 10 mm. In the bathroom and toilets will be ceramic cladding, heights are specified in the drawings, types and colors will be chosen by investor. Flooring surface will be made from ceramic tiles and wooden parquets. Patterns and colors will be chosen by investor. Compositions of the floors are in the list of the flooring compositions in enclosure.

#### **c.11. Infills of openings**

Outside windows and doors are designed as triple glass, white plastic SULKO profi line with heat transfer coefficient  $U=0,7 \text{ W/m}^2\text{K}$ . External and internal windows sills are part of the delivery. Acrylate skylight Omniplast which can be used as an entrance to the flat roof is four-layered with heat transfer coefficient  $U=1,29 \text{ W/m}^2\text{K}$ . All

interior doors have been designed as a full and smooth from the SAPELI manufacturer with standard oak surface finishing. All the openings are described in the list of the openings in enclosure.

#### **c.12. Isolation against outside moisture and radon**

In the foundations is used like a protection against radon and external moisture waterproofing layer Glasstek 40 Special mineral. Waterproofing layer of the roof is from PVC foil S PES ALKORPAN 35176.

#### **c.13. Thermal insulation**

All structures are designed in order to achieve low energy standard. Details are designed to minimize the thermal bridges. Floor on the ground is insulated by Isover EPS 150 S Stabil of the thickness 200 mm. External walls are insulated by Isover EPS 70F of the thickness 200 mm. Roof is insulated by EPS 150 S Stabil of the thickness 200 mm.

#### **c.14. Sheet metal constructions**

On the external windows sills, sheeting of attic are used sheet metal components made of galvanized sheet metal of the thickness 0,7 mm.

### **d) Connection of the building to technical infrastructure**

All engineering networks are prepared on the edge of parcel.

#### **Technical equipment**

##### Engineering networks and connections

On public sewerage system DN 500, water supply pipe LP80, low pressure gas pipe DN 90 and electricity cables are connected with lines going to family house, placing of connection is drawn in coordinating situation. On sewer connection is prepared inspection shaft, diameter 800 mm, size of sewerage connection DN 150 mm. Size of water supply connection is DN 25, necessary is water meter shaft with dimensions 900 x 1200 mm. Main closing valve of gas supply pipe is installed in fence column in south-east edge of parcel.

##### Building services pipelines

Water distribution in building, sewer piping and electricity lines are solved by specialized projects. For heating is design condensing gas boiler Protherm Panther 12 KTO.

### **e) Addressing technical and transport infrastructure, including transport solutions in peace, the conditions relating to the building design and undermined area**

Solving technical and transport infrastructure is not required. The building is not on the undermined area.

### **f) Environmental impact and its protection solution**

Building and its use will not have a negative impact on the surrounding environment.



During the use of building will be produced only municipal waste which will be deposited in containers on given place and taken out by the authorized company.

During construction will be respected all rules of hygiene regulations, particularly noise and dust production. The proposed technology does not arise any hazardous waste during the construction works.

Due to the characteristics of the building and its location, it won't have a negative impact on flora, fauna and ecosystems in the area won't affect any architectural or archaeological monuments or protected parts of the nature.

With produced wastes will be handled in accordance with applicable public requirements and to the eventual use or destruction will be transmitted only to authorized persons within the meaning of Act. 185/2001 Coll. about waste.

There will be made a register of produced wastes in accordance with public notice 383/2001 Coll. about details of handling with waste.

#### **g) Barrier free solution on public areas and roads**

This project does not need to fulfill conditions for people with reduced mobility.

#### **h) Survey and measurement**

Radon index was evaluated from the radon map of Czech Geological Survey.

Dominant level of risk in the selected area is 1-low (from scale 1-4)-waterproofing layer (Glastek 40 special mineral) is sufficient for radon protection of the building. It is detaily described in the radon report which is enclosed.

There was done a geological survey, which is in the enclosure.

#### **i) Basis for staking layout – referential site and elevation system**

Plot boundaries are set out, coordinate system is JTSK elevation system BPV.

#### **k) Influence upon neighboring properties**

The project is designed to achieve compliance with the layout of networks and sufficient distance from buildings and other facilities respectively will not increase substantially the effects and impacts on surrounding land and buildings. For short time may increase noise and dust. During the construction work will be need to clean wheels of the vehicles to prevent pollution of communications.

#### **l) Ensuring health protection and safety of work**

During earthworks will be necessary to use heavy mechanisms that can be a source of danger of health. Before and during construction must be of all staff advised about BOZ. At the same time performs learn and introduction of all workers with conditions on site and notice to the places where extra caution is needed.

For individual construction workers valid, all the safety measures resulting of Act No. 309/2006 Coll., Government Regulation 591/2006 Coll. and other related legislation laying down the principles to ensure BOZ. All workers are required to wear protective equipment. Explosives are not used.

Earthworks in the vicinity of underground lines must be done manually to avoid damage to the device and personnel injuries. The supplier is obliged to secure the excavation so as to

avoid any persons falling into the excavation.

At night it is necessary to illuminate the excavation, if is not secured by public lighting. At the same time has to be ensuring access to the neighboring objects by using the footbridges fitted with railings.

#### **4. Mechanical endurance and stability**

The building is designed so that the load acting on it during the construction and use should not result in:

- a) Collapse of building or part of the building
- b) Inadmissible degree of deformation of structure
- c) Damage to other parts of building or installations or equipment as a result of bigger deformation of load-bearing construction

Static calculations are done by authorized static engineer and it is a separate part of the project. Construction works will be done according this project and static assessment. All products used in construction will fulfill relevant standards, technical data sheets will be submitted for final building approval.

##### **a) Fire safety**

Fire solution is processed by authorized engineer and is a separate part of the project documentation. Each structural part designed according to this solution.

##### **b) Hygiene, health protection and protection of environment**

Waterproofing layer on the ground has sufficient properties to protect inhabitants against radon influence.

Lightning of living space is sufficient by natural light through the windows. Lightning and insulating fulfills requirements of standards CSN 734301 and CSN 730590.

The ventilation will be handled manually (through windows and doors). Kitchen is equipped with fume hood with carbon filters ensuring of absorbing odors.

Due to the characteristics of the building and its location, it won't have a negative impact on flora, fauna and ecosystems in the area won't affect any architectural or archaeological monuments or protected parts of the nature.

##### **c) Safety during usage**

General rules are applied during the utilization. Project documentation is designed in accordance with public notice no. 137/1998 Coll. about general technical requirements for building and amended by public notice 502/2006 Coll.

Staircase must be designed in safe way. Height of handrails on stairways of minimal 1 m must be kept. Further must be carried out in accordance with CSN 743305 Guard rails. The vertical gap mustn't be wider 180 mm and horizontal gap up to 120 mm. Ground plan projection of gap between the railing and the edge of walking surfaces has not to be larger than 50 mm.

##### **d) Noise protection**

Structures are designed to fulfill conditions of CSN 730532 Acoustics – Noise protection in building and acoustic properties of materials. Project documentation is designed in accordance with public notice no. 148/2006 Coll. about health protection against

unfavorable actions of noise and vibration. All installations will be properly insulated. Risers of sewerage will be covered by mineral wool for sound absorption as well as downloads from the roof. Inner walls satisfy requirements for acoustics (related to their type of usage). External walls satisfy limits for airborne sound penetration. The surrounding area is planned to be used for living, no sources of extensive noise are known or planned.

#### **e) Energy saving and protection against heat losses**

Project documentation is designed in accordance with law no. 406/2006 Coll. about handling with energy. Energy performance certificate is separate part of building documentation. Building belongs to the group B.

Thermal insulation has been designed to satisfy U-values given by standards (see report for U-values calculation).

#### **f) Use of building for men with reduced ability of movement and orientation**

Project documentation is designed in accordance with law no. 183/2006 Coll. Building law and public notice 369/2001 Coll. about general requirements for use of buildings by man with reduced ability of movement and orientation.

#### **g) Protection of the building against detrimental environmental effects**

According to the information from radon maps, there is a low radon index degree related to this building site; the building doesn't need to have additional radon insulation-waterproofing layer (Glastek 40 special mineral) is sufficient for radon protection of the building.

Building does not need any protection against aggressive ground water, seismicity or undermining.

#### **h) Protection of population**

Building satisfies requirements stated in standards and does not require any additional protective solution.

#### **i) Engineering of networks**

Building will be connected to the public water supply pipeline, sewerage pipeline and low voltage electricity cable and gas pipeline. Which are located on the borders of the plot.

#### **j) Traffic solution**

Building will be connected to the existing road.

#### **k) Production and non-production technological building appliances**

They are not present in the building; it is not use for any kind of production.

## Energy report of building envelope

### Identification data

|  |                                   |
|--|-----------------------------------|
| Type of building                         | Family House                      |
| Address (city, street, postcode)         | Olomouc, Zirmova street, 779 00   |
| Cadastral area and cadastral place       | Nová Ulice (okres Olomouc);710717 |
| Proprietor or corporation of proprietors | Jan Novák                         |
| Address                                  | Polívkova 14, Olomouc             |
| Phone number                             | 727282999                         |

### Building characteristic

|   |                             |
|---|-----------------------------|
| Volume of building V – external volume of heated zone, excluding loggias, labels, attics and foundation | <b>789,75 m<sup>3</sup></b> |
| Total area A – sum of external areas of cooled constructions bordering volume of building               | <b>419,51 m<sup>2</sup></b> |
| Volume factor of building A/V   | <b>0,53</b>                 |
| Overbearing internal temperature in heating period  | 20 °C                       |
| External design temperature in winter period  | -15 °C                      |

### Energy characteristic of important cooled constructions

| Construction                                     | Reference building (determination of requirement) |   |                                    |  | Evaluated Building        |                                      |                                    |   |
|--|---|---|------------------------------------|--|---------------------------|--------------------------------------|------------------------------------|---|
|  | Area A (m <sup>2</sup> )                          | Required (recommended) coef. of heat transfer U (W.m-2.K-1) | Temperature reduction factor b (-) | Specific loss by heat transfer HT = Ai.Ui.bi (W.K-1) | Area A (m <sup>2</sup> )  | Coef. of heat transfer U (W.m-2.K-1) | Temperature reduction factor b (-) | Specific loss by heat transfer HT = Ai.Ui.bi (W.K-1)            |
| External walls                                   | 240,7   | 0,30(0,25)  | 1,0                                | 60,175   | 240,7                     | 0,16                                 | 1,0                                | 38,512  |
| Floor above the ground                           | 126,4   | 0,45(0,30)  | 0,43                               | 16,3   | 126,4                     | 0,17                                 | 0,43                               | 9,239   |
| Ceiling from heated area to non-heated area      | 21,0  | 0,60 (0,40)   | 0,54                               | 4,536  | 21,0                      | 0,2                                  | 0,54                               | 2,268   |
| Wall from heated area to non-heated area         | 26,1  | 0,60 (0,40)   | 0,29                               | 3,0276   | 26,1                      | 0,4                                  | 0,29                               | 3,027   |
| Flat roof construction                           | 126,4   | 0,24 (0,16)   | 1,0                                | 20,224   | 126,4                     | 0,13                                 | 1,0                                | 16,432  |
| Windows  | 36,1  | 1,50 (1,20)   | 1,0                                | 43,32  | 36,1                      | 0,7                                  | 1,0                                | 25,270  |
| Doors  | 7,4   | 1,70 (1,20)   | 1,0                                | 8,88   | 7,4                       | 1,0                                  | 1,0                                | 7,400   |
| Total  | 584,10  |   |                                    | 156,46   | 584,10                    |                                      |                                    | 102,148   |
| Thermal links                                    |   | 584,10*0,02   |                                    | 11,68  |                           | 584,10*0,02                          |                                    | 11,68   |
| Total specific heat loss by transmission         |   |   |                                    | 168,14   |                           |                                      |                                    | 113,828   |
| Average coefficient of heat transmission         |   | $\sum (U_{N,i} \cdot A_i \cdot b_i) / \sum A_i + 0,02$      |                                    | Required value:0,37<br>Recommended: 0,28             |                           | 113,828/584,10                       |                                    | <b>0,195</b><br>Satisfies to the required and recommended value |
| Classification class of the envelope of building |   |   |                                    | 0,195/0,37=0,52                                      | <b>Class B-sufficient</b> |                                      |                                    |   |

Constructions fulfill the requirements on overall coefficient of heat transfer according to ČSN 73 0540-(2011).

**Classification class of heat transfer by envelope of evaluated building**

| Rating category | Word explanation   | $U_{em}$ ( $W \cdot m^{-2} \cdot K^{-1}$ )             | Classification indicator CI             |
|-----------------|--------------------|--|---|
|                 |                    | Generally  |   |
| A               | Very economical    | $U_{em} \leq 0,5 \cdot U_{em,N}$                       | 0,5<br>0,75<br>1,0<br>1,5<br>2,0<br>2,5 |
| B               | Economical         | $0,5 \cdot U_{em,N} < U_{em} \leq 0,75 \cdot U_{em,N}$ |   |
| C               | Satisfactory       | $0,75 \cdot U_{em,N} < U_{em} \leq U_{em,N}$           |   |
| D               | Inconvenient       | $U_{em,N} < U_{em} \leq 1,5 \cdot U_{em,N}$            |   |
| E               | Wasteful           | $1,5 \cdot U_{em,N} < U_{em} \leq 2 \cdot U_{em,N}$    |   |
| F               | Very wasteful      | $2 \cdot U_{em,N} < U_{em} \leq 2,5 \cdot U_{em,N}$    |   |
| G               | Extremely wasteful | $U_{em} > 2,5 \cdot U_{em,N}$                          |   |

Classification : **B**

Date of issuance of energy label: 1.5.2012

Author of energy label: Michal Reiter

Address of author: Mošnerova 17, Olomouc 779 00

IČO: \_

Author: Michal Reiter

Signature:.....

This report and energy label is in accordance with European directive and council number 2002/91/ES and EN 15217. It was done in accordance with ČSN 73 0540(2011) and according to project documentation of building.

# ENERGY LABEL OF BUILDING ENVELOPE

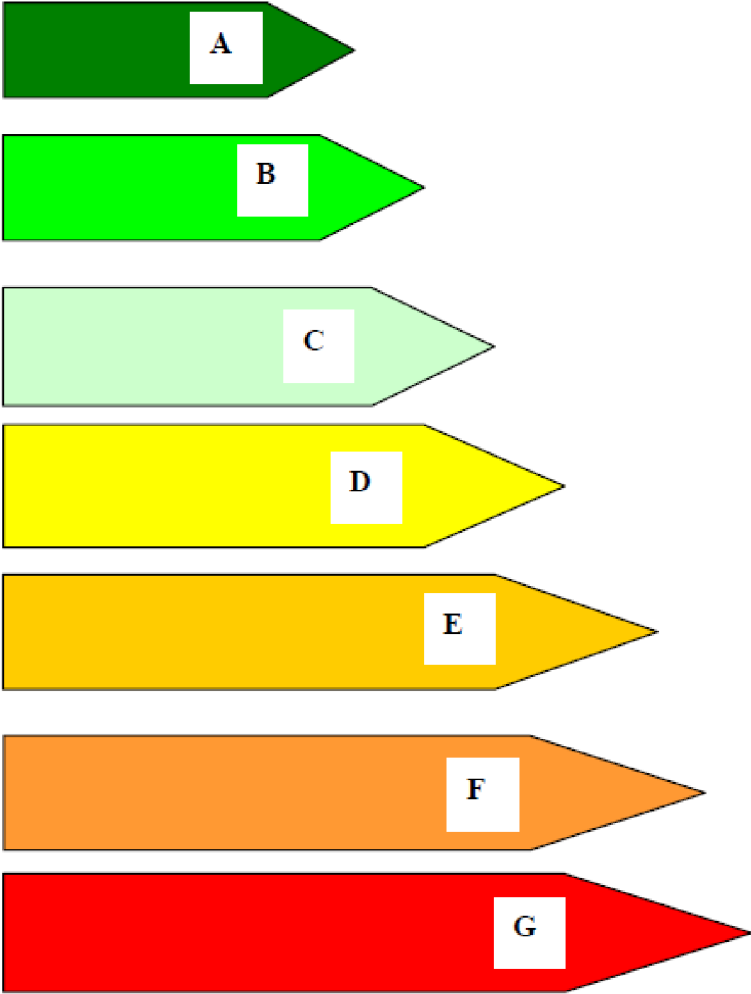
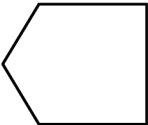
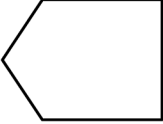
|  |      |   |   |      |      |      |
|--|------|---|---|------|------|------|
| Type of building: Family house<br>Address: Zirmova street, Olomouc 779 00  |      | Evaluation of building envelope   |   |      |      |      |
| Total surface area: $A_c = 419,51\text{m}^2$   |      | actual  | recommended   |      |      |      |
| <p><i>CI</i></p>                   |      |  |  |      |      |      |
| <b>CLASSIFICATION</b>  |      | B   | B   |      |      |      |
| Mean coefficient of heat transfer $U_{em}$ ( $\text{W} \cdot \text{m}^{-2} \cdot \text{K}^{-1}$ )<br>$U_{em} = HT/A$ |      | <b>0,195</b>  | 0,28  |      |      |      |
| Required coef. of heat transfer $U_{em,N}$ ( $\text{W} \cdot \text{m}^{-2} \cdot \text{K}^{-1}$ )                    |      | 0,370   |   |      |      |      |
| Classification indicators and their corresponding values of $U_{em}$ for $A/V = 0,53 \text{ m}^2/\text{m}^3$         |      |   |   |      |      |      |
| CI   | 0,5  | 0,75  | 1,0   | 1,5  | 2,0  | 2,5  |
| $U_{em}$   | 0,19 | 0,28  | 0,37  | 0,56 | 0,74 | 0,93 |
| Validity of label until:   |      |   | Date: 1.5.2012<br>Name and surname: Michal Reiter                                   |      |      |      |

## BACHELOR'S THESIS

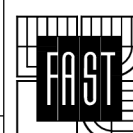

VUT V BRNĚ  
 FAKULTA STAVEBNÍ  
 VEVEŘÍ 331/95  
 602 00 Brno  
 TEL. 541 141 111

DEPARTMENT OF CIVIL ENGINEERING

STUDENT

Michal Reiter

SUP. OF BA. WORK

doc. Ing. Jiří Sedlák, CSc

LOW ENERGY DETACHED HOUSE

FORMAT

A4

DATE

5/2012

GEOLOGICAL REPORT-SURVEY

SCALE

DRAWING N.  
5

## **1. Identification data**

### Name of the document:

Geological report of foundation proportions of detached family house in the street Zirmova

### Place of the building object:

City: Olomouc  
Street: Zirmova  
Cadastre area: Nová Ulice (district Olomouc);710717  
Plot number: 153/29

### Investor:

Name: Jan Novák  
Address: Polívkova 14  
77900, Olomouc

### Processor:

Name: Michal Reiter  
Address: Mošnerova 17  
77900, Olomouc

## **2. Used background papers**

- Olomouc - Final report of engineering geological survey for garages and classrooms at Tabulový vrch in Olomouc (GEOTEST n.p. Brno, 1977, f.n. 11556-IG, J.Reminěk)
- Olomouc – Tabulový vrch, Final report of engineering geological survey of the foundations proportions on the construction site in the area of barracks at Tabulový vrch in Olomouc (GEOTEST n.p. Brno, 1986, f.n. 860079, A.Paseka)
- Geological map of the Czech Republic, scale 1:50 000, leaf 24-22 Olomouc

## **3. Overview of geological and hydrogeological conditions**

Studied area belongs to the province of Západní Karpaty, system of Vněkarpatské sníženiny, subsystem of Západní Vněkarpatské sníženiny Hornomoravského úvalu, subsystem Prostějovské pahorkatiny.

Geologically interested area belongs to Neocene-lake cycle-Pliocene. It is freshwater series of sands and clays, which surface was measured in the depth of 0,7-1,5 m under the surface of nowadays area.

It is changing of white, yellow, green, red and brown fine to rough granular, calcareous silicate sands. Often there are sandy, talc non-calcareous clays with siliceous grains.

Water level of the underground water was found in the borehole J7 at the depth of 10,3-11,3 m under the terrain.



#### **4. Anticipated characteristic geological profile**

Borehole J7

Spot height: 255,1 m a. s. l.

Borehole master: P.Hoffmann, UGB

Drilled: 27.2.1986

0,0-0,5 m Argillaceous soil red-brown, gray pigmented, stiff

1,8-2,7 m Argillaceous soil sandy brown, stiff

2,7-3,6 m Argillaceous soil red-brown, gray pigmented, stiff

3,6-4,1 m Clay-sand fine grained yellow-green, lie down

4,1-6,5m Argillaceous soil sandy, red-brown, stiff

6,5-12,0m Argillaceous soil sandy, yellow-brown, stiff

Water level impacted in the depth of 10,3 m under the terrain.

Borehole ended in the depth of 12,0 m.

#### **5. Geotechnical properties of the soils**

Laboratory of the soil mechanics processed the samples of soils. Results of the laboratory analysis were geotechnically evaluated and below are soil properties characteristics recommended for static calculations.

Pliocene sediments

a) Clays and sandy clays

-have index of plasticity  $I_p=0,207-0,282$  they are highly plastic soils of the class F6Cl

Bulk weight  $\rho_n = 2025 \text{ kg.m}^{-3}$

Total adhesion  $c_u = 0,1 \text{ MPa}$

Total angle of inner friction  $\Phi_u = 0^\circ$

Effective adhesion  $c_{\text{eff}} = 0,01 \text{ Mpa}$

Effective angle of inner friction  $\Phi_{\text{eff}} = 25^\circ$

Oedometric modulus deformation

-for the scale of stress: 60-100 kPa  $E_{\text{oad}} = 5,9 \text{ MPa}$

100-200 kPa  $E_{\text{oad}} = 7,8 \text{ MPa}$

60-100 kPa  $E_{\text{oad}} = 9,4 \text{ MPa}$

b) Argillaceous soil sandy (sandy soil)

-have index of plasticity  $I_p=0,100-0,190$  and they belong between middle plastic soils of the class F6Cl

Bulk weight  $\rho_n = 2110 \text{ kg.m}^{-3}$

Total adhesion  $c_u = 0,1 \text{ MPa}$

Total angle of inner friction  $\Phi_u = 0^\circ$

Effective adhesion  $c_{\text{eff}} = 0,01 \text{ Mpa}$

Effective angle of inner friction  $\Phi_{\text{eff}} = 20^\circ$



## BACHELOR'S THESIS

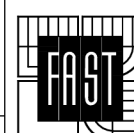

VUT V BRNĚ  
 FAKULTA STAVEBNÍ  
 VEVEŘÍ 331/95  
 602 00 Brno  
 TEL. 541 141 111

DEPARTMENT OF CIVIL ENGINEERING

STUDENT

Michal Reiter

SUP. OF BA. WORK

doc. Ing. Jiří Sedlák, CSc

LOW ENERGY DETACHED HOUSE

FORMAT

A4

DATE

5/2012

RADON REPORT-SURVEY

SCALE

DRAWING N.  
6



---

## **RADON V PODLOŽÍ**

**Posudek číslo:** 16099

**Datum:** 20. květen 2012

**Lokalizace:** souřadnice středu vybraného území (S-JTSK):  
X = 1122290, Y = 548678  
katastrální území:  
obec:

**Rozsah území:** 500 m x 500 m

---

## ÚVOD - informační služba

- Informační služba poskytuje **signální informaci** o předpokládané přítomnosti zdraví nebezpečného prvku **radonu v podloží (radonový index)**. Má sloužit jako výchozí podklad pro práci specialistů i pro větší informovanost veřejnosti a usnadnění řešení životních situací jednotlivých občanů. Veřejnosti však doporučujeme konzultovat se specialisty jakákoliv vážná rozhodnutí, která by chtěla učinit na základě tohoto reportu, a to především v případě vyšších stupňů rizikovitosti.
- **Report nenahrazuje lokální odborný průzkum ani posudek!**
- **Mapa radonového indexu** vyjadřuje převažující kategorii radonového indexu v jednotlivých geologických jednotkách nebo horninových typech na základě statistického zpracování dat o radonu z podloží. Horninové typy jsou označeny čtyřmi **kategoriemi radonového indexu - nízký, přechodný, střední a vysoký**. Přechodný index je používán pro nehomogenní kvartérní sedimenty (mezi nízkým a středním indexem).
- **Mapy radonového indexu** jsou primárně určeny pro rozmísťování stopových detektorů do objektů a v žádném případě z nich nelze odečítat kategorii radonového indexu na stavebním pozemku **před novou výstavbou**. To je možné provést **pouze měřením na konkrétní lokalitě podle metodiky schválené Státním úřadem pro jadernou bezpečnost (SÚJB)**. Signální informace poskytované službou jsou však důležité jako výchozí základní informace pro předpoklad potřeby lokálního měření a protiradonových opatření při zakládání a rekonstrukci staveb a při používání lokálních zdrojů podzemní vody jako pitné.
- Informační služba prezentuje také konkrétní evidované (SÚJB) hodnoty **lokálních měření radonového indexu** geologického podloží. Jako doplňující údaj jsou uvedeny geometrické průměry výsledků **měření radonu v budovách** za jednotlivá katastrální území (SÚRO), které odrážejí především radonový index podloží, účinnost konkrétních protiradonových opatření a případně i obsah radonu v použitých stavebních materiálech budov.

## OBSAH

**Geografická lokalizace** vybraného území v základní topografické mapě 1:50 000

**Geologická charakteristika** vybraného území - geologická mapa v měřítku 1:50 000 (GEOČR50)

**Charakteristika území z hlediska radonu v podloží - mapy** vybraného území: mapa radonového indexu geologického podloží vycházející z geologické mapy a mapa lokálních měření radonového indexu geologického podloží

**Charakteristika území z hlediska radonu v podloží - popis** vybraného území z hlediska sledovaného geofaktoru a plošný rozsah jednotlivých zastižených kategorií radonového indexu

**Závěr a doporučení** shrnuje údaje o převládajícím a nejvyšše dosaženém stupni rizikovitosti sledovaného geofaktoru a základní doporučení pro uživatele.

**Kontakty** na odborného garanta služby a oblastního geologa

**Odkazy na související informace** k tématu reportu

**Definice použitých pojmů** a nezbytných odborných termínů a popis fenoménu

**Nejdůležitější legislativa**

## HODNOVĚRNOST DAT

Na sestavování reportu byly použity vstupní podklady v měřítku 1:50 000. Proto i vypovídající schopnost reportu odpovídá tomuto rozlišení.

## AUTORSKÁ PRÁVA

Report je dílo chráněné autorským právem podle autorského zákona, neboť zhotovitel je vlastníkem autorských práv k němu. Reporty jsou volně zpřístupněny na internetu a určeny výhradně k individuální potřebě fyzických nebo právnických osob. Jiné užití díla, např. pro komerční účely, je možné výhradně na základě písemného souhlasu České geologické služby. Neoprávněné užití nebo rozšiřování posudku je porušením autorského, popř. trestního zákona či projevem nekalé soutěže podle příslušných ustanovení Obchodního zákoníku. Každá kopie reportu bude opatřena doložkou © Česká geologická služba 2007.

**GEOGRAFICKÁ LOKALIZACE**

Mapa 1. Topografie ZM 1:50 000

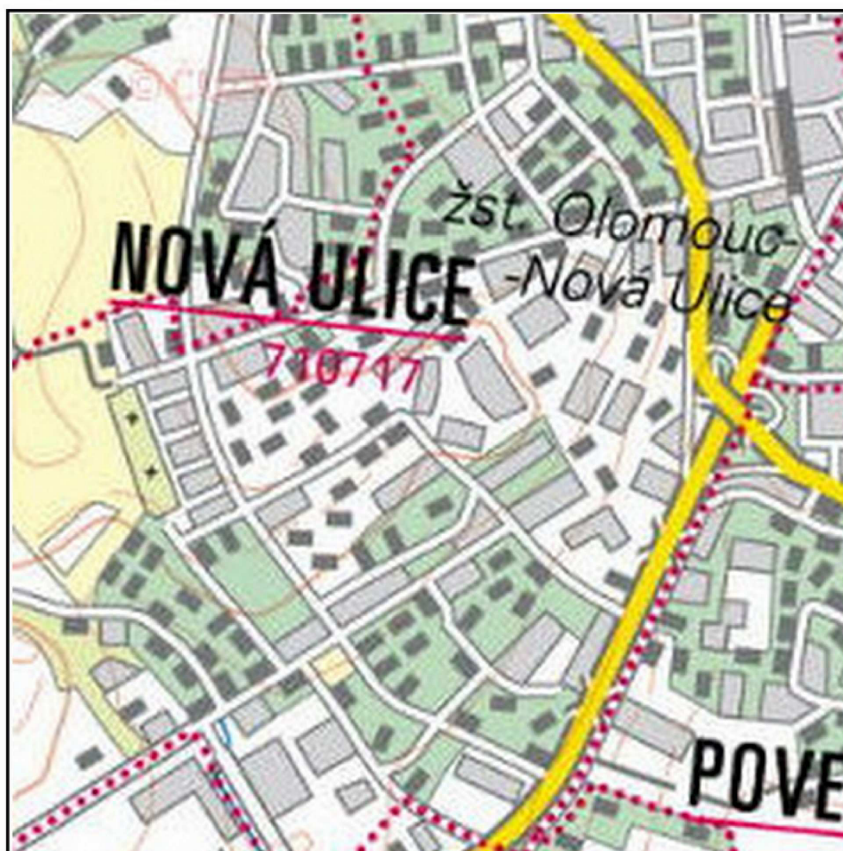

Měřítko 1 : 25 000 (1 cm = 250 m)



vybrané území

0 0,5 1 km

**Způsob výběru lokality:** výběrem v mapě**Lokalizace:** souřadnice středu vybraného území (S-JTSK): X = 1122290, Y = 548678

katastrální území:

obec:

kraj:

**Rozsah území:** 500 m x 500 m**Zasažené mapové listy ZM 1 : 50 000 (ČÚZK):**



**GEOLOGICKÁ CHARAKTERISTIKA**

Mapa 2. Geologie (GEOČR50)

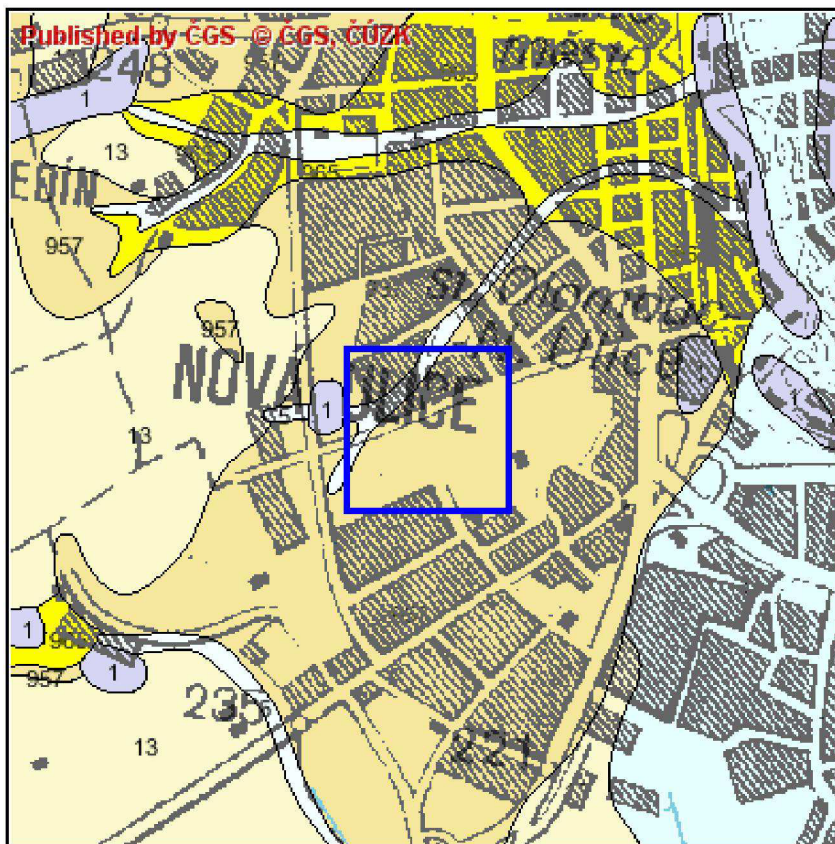

Měřítko 1 : 25 000 (1 cm = 250 m)

 vybrané území 0 0,5 1 km**Legenda**

Index homina - typ horiny - stáří

**REGION: KVARTÉR ČESKÉHO MASIVU A KARPAT**

- 1** antropogenní uloženiny, vytěžené prostory - sedimenty nezpevněné - kvartér
- 4** nívní sedimenty (hlína, písek, štěrk) - sedimenty nezpevněné - kvartér
- 5** splachové sedimenty (hlína, písek, štěrk) - sedimenty nezpevněné - kvartér
- 13** naváté sedimenty (spraš, sprašová hlína) - sedimenty nezpevněné - kvartér

**REGION: KARPATSKÁ PŘEDHLUBEŇ**

- 957** jezerní a říční sedimenty (písek, štěrk, prach, jíl) - sedimenty nezpevněné - neogén
- 965** mořské sedimenty (vápnitý jíl, písek) - sedimenty nezpevněné - neogén

## CHARAKTERISTIKA ÚZEMÍ Z HLEDISKA RADONU V PODLOŽÍ - MAPY

Mapa 3. Radonový index geologického podloží

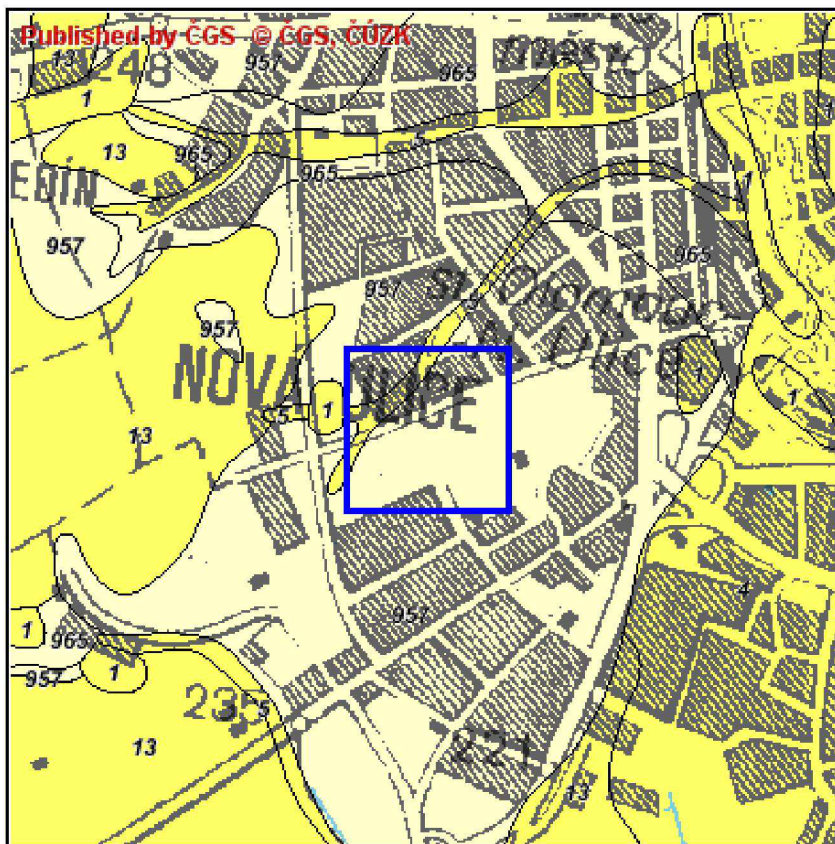









Měřítko 1 : 25 000 (1 cm = 250 m)

 vybrané území

0 0,5 1 km

### Legenda

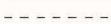
Převažující kategorie radonového indexu geologického podloží:

-  nestanovena
-  nízká - 1
-  přechodná (nehomogenní kvartérní sedimenty) - 2
-  střední - 3
-  vysoká - 4
-  zlomy a jiná tektonika (zvýšené radonové riziko)
-  zlomy a jiná tektonika (zvýšené radonové riziko)
-  kontury geologických jednotek  
(čísla uvnitř jednotek odpovídají jednotlivým horninám)



Mapa 4. Lokální měření radonového indexu geologického podloží

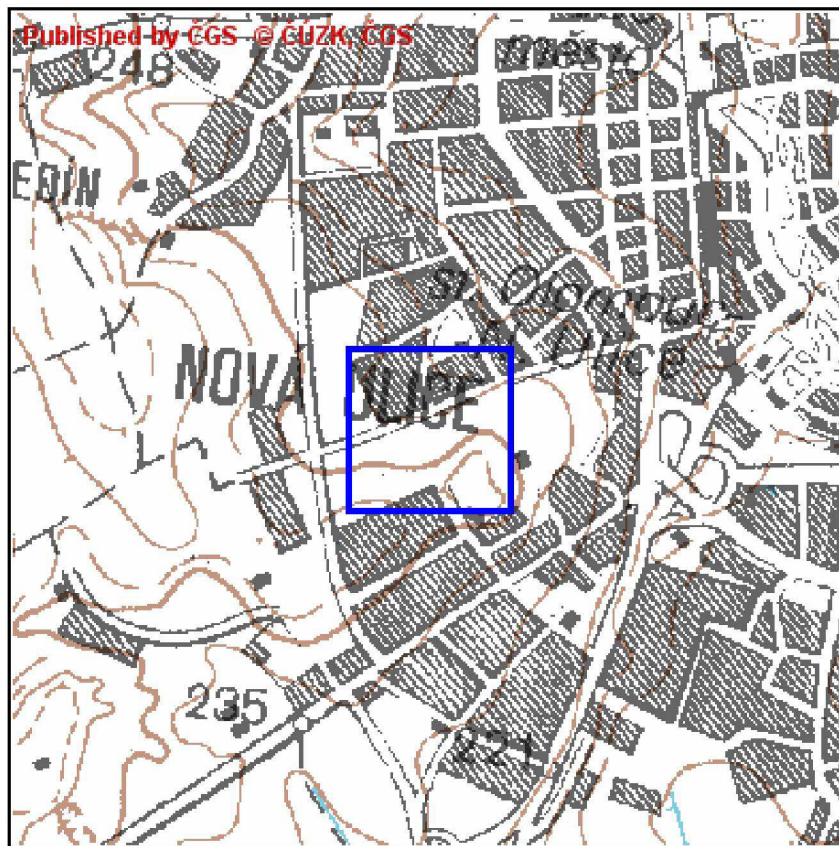

Měřítko 1 : 25 000 (1 cm = 250 m)

 vybrané území

0 0,5 1 km

Počet zastižených objektů: 0

**Legenda**

Kategorie radonového indexu geologického podloží měřených lokalit

-  neurčena
-  nízká - 1
-  střední - 2
-  vysoká - 3

**5049**

-  číslo objektu (měřená lokalita)

-  hranice katastrálního území

## CHARAKTERISTIKA ÚZEMÍ Z HLEDISKA RADONU V PODLOŽÍ - POPIS

**Jaká je kategorie radonové indexu zastižených hornin geologického podloží ve vybraném území?**

viz mapa 2,3

| Plocha vybraného území [%] | Radonový index |               | Hornina       |                         |               |
|----------------------------|----------------|---------------|---------------|-------------------------|---------------|
|                            | Kategorie      | Stupeň rizika | Legenda číslo | Horninový typ           | Stáří - útvar |
| 90                         | nízký          | 1             | 1810          | písek, štěrk, silt, jíl | neogén        |
| 10                         | přechodný      | 2             | 7             | sediment smíšený        | kvartér       |

**Jaká je kategorie radonového indexu geologického podloží konkrétních měřených lokalit evidovaných ve vybraném území?**

viz mapa 4, data SÚJB

| Objekt číslo | Lokalita | Průměrná koncentrace radonu [kBqm-3] | Radonový index |               |
|--------------|----------|--------------------------------------|----------------|---------------|
|              |          |                                      | Kategorie      | Stupeň rizika |
|              |          |                                      |                |               |

**Jaká je průměrná koncentrace radonu (geometrický průměr) v dosud měřených budovách v katastrálních územích vybraného území?**

viz mapa 4, data SÚRO

|  |  |  | Průměrná koncentrace radonu [kBqm-3] |  |
|--|--|--|--------------------------------------|--|
|  |  |  |                                      |  |
|  |  |  |                                      |  |



## ZÁVĚR A DOPORUČENÍ

### – převládající stupeň rizikovosti ve vybraném území

rizikový geofaktor: radon v podloží (radonový index)

převládající stupeň rizika: **1 - nízká** ze škály 1-4 \*

rozsah z plochy vybraného území: 90%

viz mapa: 3

omezení využití území a doporučení:

V této části území s velkou pravděpodobností nebudou potřeba speciální protiradonová opatření; u výstavby postačí běžná hydroizolace. Místní zdroje podzemní vody budou z hlediska obsahu radioaktivních prvků pravděpodobně splňovat hygienické limity pro pitné účely.

### – nejvyšší dosažený stupeň rizikovosti ve vybraném území

rizikový geofaktor: radon v podloží (radonový index)

nejvyšší dosažený stupeň rizika: **2 - přechodná** ze škály 1-4 \*

rozsah z plochy vybraného území: 10%

viz mapa: 3

omezení využití území a doporučení:

Je nutné počítat s možností zvýšené koncentrace radonu v podloží. Doporučuje se odborné změření koncentrace radonu v podloží v místě vaší plánované stavby, příp. změření radonu ve stávajícím objektu. Při využívání místních zdrojů podzemní vody pro pitné účely se doporučuje analýza podzemní vody na radioaktivní prvky.

Případné aktivity ve vybraném území doporučujeme konzultovat s odborníkem.

\* riziko vrůstá s vyššími čísly škály

## KONTAKTY

Pokud budete potřebovat geologické informace přesahující obsah reportu, navštivte internetové stránky České geologické služby [www.geology.cz](http://www.geology.cz) nebo kontaktujte odborného garanta této služby [www.geohazardy.cz](http://www.geohazardy.cz) nebo příslušného oblastního geologa [www.geology.cz/extranet/sqs/sqg](http://www.geology.cz/extranet/sqs/sqg).



## ODKAZY NA SOUVISEJÍCÍ INFORMACE

Portál Státní geologické služby [www.geologickaslužba.cz](http://www.geologickaslužba.cz)

Česká geologická služba [www.geology.cz](http://www.geology.cz)

Státní ústav radiační ochrany [www.suro.cz](http://www.suro.cz)

Státním úřadem pro jadernou bezpečnost - Registr [www.sujb.cz](http://www.sujb.cz)

## DEFINICE POUŽITÝCH POJMŮ A POPIS FENOMÉNU

- **Radon (Rn-222)** je zdraví nebezpečný prvek, který vzniká radioaktivní přeměnou uranu U-238. Radon může pronikat do objektů jednak z hornin a zemín, které jsou pod základy staveb, jednak z vody, dodávané do objektů a také ze stavebních materiálů, jejichž základem jsou obvykle přírodní materiály. Hlavním a trvalým zdrojem radonu je však horninové prostředí. V určitých typech hornin a zemín jsou různé obsahy radonu v závislosti na jejich vývoji a složení.
- **Jak dlouho působí?** Radon je generován z podložních hornin neustále, vzhledem k poločasů přeměny mateřského prvku uranu U-238 (cca 4,5 miliardy let) je uvolňování radonu časově neomezeným jevem.
- **Čím je nebezpečný?** Radon se váže se na aerosoly v ovzduší, které při vdechnutí ulpívají na plicní výstelce a zvyšují tak vnitřní ozáření lidského organismu, způsobující rakovinu plic.
- **Jaké jsou doporučené postupy chování?** Detailní doporučené postupy pro snížení expozice radonu jak v podzemní vodě, v existujících objektech, tak i při výstavbě nových objektů naleznete na internetových stránkách [www.suro.cz](http://www.suro.cz).
- **Kdo získává informace o geofaktoru?** Problematikou radonu v podloží se zabývá Česká geologická služba (ČGS, [www.geology.cz](http://www.geology.cz)), problematikou koncentrace radonu v budovách, stavebních materiálech a ve vodních zdrojích se zabývá Státní ústav radiační ochrany (SÚRO, [www.suro.cz](http://www.suro.cz)). Praktická měření koncentrace radonu provádějí firmy s povolením k činnosti vydaném Státním úřadem pro jadernou bezpečnost (SÚJB, [www.sujb.cz](http://www.sujb.cz) - Registr).
- **Co je to radonový index?** Radonový index (dříve radonové riziko) je kombinací třetího kvartilu koncentrace radonu v souboru 15 měřených hodnot na stavebním pozemku a výsledné propustnosti horninového prostředí. Stavební pozemky jsou charakterizovány třemi **kategoriemi radonového indexu: nízká, střední, vysoká**. Podle výsledné kategorie radonového indexu pozemku navrhnou certifikované firmy způsob založení objektu a ochrany proti pronikání radonu z podloží.

## Nejdůležitější legislativa

- **Vyhláška Státního úřadu pro jadernou bezpečnost č. 307/2002 Sb.**, ve znění vyhlášky č. 499/2005 Sb., o radonu v podloží a v objektech.
- **Vyhláška č. 462/2005 Sb.**, o distribuci a sběru detektorů k vyhledávání staveb s vyšší úrovní ozáření z přírodních radionuklidů a stanovení podmínek pro poskytnutí dotace ze státního rozpočtu.



**VYSOKÉ UČENÍ TECHNICKÉ V BRNĚ**  
BRNO UNIVERSITY OF TECHNOLOGY

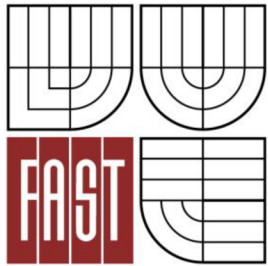

**FAKULTA STAVEBNÍ**  
**ÚSTAV POZEMNÍHO STAVITELSTVÍ**

FACULTY OF CIVIL ENGINEERING  
INSTITUTE OF BUILDING STRUCTURES

## FOLDER C4 – FIRE SAFETY

**BAKALÁŘSKÁ PRÁCE**  
BACHELOR'S THESIS

**AUTOR PRÁCE**  
AUTHOR

Michal Reiter

**VEDOUCÍ PRÁCE**  
SUPERVISOR

doc. Ing. JIŘÍ SEDLÁK, CSc.

BRNO 2012

## **FOLDER CONTENT**

1. FIRE SAFETY REPORT

2. SITUATION - FIRE PREVENTION DISTANCES 1:200



## BACHELOR'S THESIS

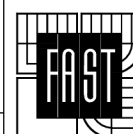

VUT V BRNĚ  
 FAKULTA STAVEBNÍ  
 VEVEŘÍ 331/95  
 602 00 Brno  
 TEL. 541 141 111

DEPARTMENT OF CIVIL ENGINEERING

STUDENT

Michal Reiter

SUP. OF BA. WORK

doc. Ing. Jiří Sedlák, CSc

LOW ENERGY DETACHED HOUSE

FORMAT

A4

DATE

5/2012

FIRE SAFETY REPORT

SCALE

DRAWING N.  
1

## Content:

- A) Background papers
- B) General information about construction
- C) Fire characteristic of the building
- D) Division of the building into the fire sectors
- E) Fire risk determination
- F) Construction resistance evaluation
- G) Material properties
- H) Escape ways evaluation
- I) Fire hazardous area determination
- J) Water for extinguishing
- K) Access roads
- L) Fire extinguishers
- M) Technical equipment evaluation
- N) Special requirements on the fire resistance of the constructions
- O) Fire safety devices
- P) Safety signs
- Q) Conclusion

Drawing No.2-Situation with marked fire hazard areas



## A) Background papers

Drawings of the construction part PD- Michal Reiter  
Address: Mošnerova 17, Olomouc 779 00  
Tel.: 728269288  
Email: michal.reiter@me.com  
ČSN 73 0810- Fire protection of building- General requirements  
ČSN 73 0802- Fire protection of building- Non-industrial buildings  
ČSN 730833- Fire protection of building- Buildings for dwelling and lodging  
ČSN 73 0873- Fire protection of building- Equipment for fire water supply  
Public notice 23/2008sb.  
Public notice 268/2011sb.  
Public notice 246/2001sb.

## B) General information about construction

Project documentation describes new building construction of the family house for four member family.

SO-01 Family house – it is cellarless two storey object with flat roof and garage which is a part of the house.

Object has two overground levels.

|  |                       |
|--|-----------------------|
| Built up area FH                                   | 126,36 m <sup>2</sup> |
| Floor area 1 <sup>st</sup> + 2 <sup>nd</sup> floor | 213,76 m <sup>2</sup> |

### Description of the process layout

Connection between the 1<sup>st</sup> floor and 2<sup>nd</sup> floor is provided by internal concrete staircase.  
Main entrance to the building is in the 1<sup>st</sup> floor.

### Description of the structural design

#### -vertical load-bearing constructions

-external load-bearing walls will be made from blocks Porotherm PROFI 24, with the external thermal insulation ETICS

-internal load-bearing walls will be made from blocks Porotherm AKU 25

#### -horizontal load-bearing constructions

-ceiling over the 1<sup>st</sup> floor: Porotherm brick ceiling-Miako fittings and POT girders, thickness 250 mm

#### -thermal insulations

-external walls- system ETICS: TH. 200 mm

-roof: 200 mm

#### -roof coating

-PE foil

#### -staircase

-concrete staircase

#### -openings

-windows and terrace doors are plastic

### C) Fire characteristic of the building

Object is examined acc. to ČSN 730833 as building of the category OB1.

Fire height: h=3,1 m

Construction system of FM: DP1 NON-FLAMMABLE

### D) Division of the building into the fire sectors

Object is examined as a one fire sector together with garage.

Area of f.s. A=213,76 m<sup>2</sup>

### E) Fire risk determination

Acc. to B ČSN 730833 it is determined calculation fire loading  $p_v=40 \text{ kg}\cdot\text{m}^{-2}$

Acc. paragraph 4.1.1 c) ČSN 730833:

Size of the fire sector of the building is up to 600 m<sup>2</sup>; agree with paragraph 3.5 a) ČSN 730833 for insertion into the class OB1.

### F) Construction resistance evaluation

| Material                    | Required (ČSN 730802)                | Actual values                              |
|-----------------------------|--------------------------------------|--|
| External load-bearing walls | REW 30 (1.st F.)<br>REW 15 (2.nd F.) | REI 180 DP1-POROTHERM<br>PROFI 24          |
| Internal load-bearing walls | REI 30 (1.st F.)                     | REI 180 DP1-POROTHERM<br>AKU 25            |
| Ceilings                    | RE 30 (1.st F.)                      | REI 120 DP1-POROTHERM<br>MIAKO+POT GIRDERS |
| Flat roof                   | REW 15 (1.st F.)                     | REI 120 DP1-POROTHERM<br>MIAKO+POT GIRDERS |

Thermal insulation ISOVER EPS 70 F th. 200 mm-system ETICS does not influence the fire safety of the building acc. to 4.2.4 ČSN 730833. Thermal insulation is a part of compact ETICS system which has fire reaction fire reaction class B so that it satisfies acc. to reg. 268/2011.

Roof layer

-will be made from PE foil which has fire reaction class  $B_{\text{roof},t1}$  so that it satisfies acc. to reg. 268/2011.

Fire safety strips are not demanded from buildings OB1. Height difference of roof construction is not demanded and building is designed as detached house.

Additionally, for final building approval will be submitted valid tests and certificates in accordance with appropriate paragraphs of the Public notice 246/2011.

## G) Material properties

|                                       |                        |
|---------------------------------------|------------------------|
| Masonry from the Porotherm blocks     | fire reaction class A1 |
| T.i. ISOVER EPS 70 F-ETICS            | fire reaction class B  |
| Ceilings from Porotherm POT and MIAKO | fire reaction class A1 |
| Plasterboards                         | fire reaction class A2 |

## H) Escape ways evaluation

Acc. ČSN 730833 in the living buildings of the class OB1 for the evacuation of persons is considered to satisfied DEW width 0,9 m and width of the doors for DEW 0,8 m. The length of the escape ways is not considered.

Clear width of the entrance door: 0,9 m – SATISFY

Doors on the escape way should provide easy and fast passing, shape of the fitting should avoid interception of the clothes.

Each door should be equipped with fitting which allow in the case of emergency open the door from the other side which are locked from the inside of the room.

## I) Fire hazardous area determination

Fire prevention distance depends on the size of fire open area and fire load. For evaluation of fire prevention distance we use an enclosure F, table F.1 of ČSN 73 0802.

$$p_o \geq 40\%$$

-The north elevation

- $S_p = l \times h_u = 3,75 \times 1,0 = 3,75 \text{ m}^2$
- $S_{po} = 2,25 \text{ m}^2$
- $S_{po} / S_p \times 100 = 60\% \rightarrow p_o = 60\%$
- fire prevention distance- 3,1 m

-The south elevation

- $S_p = l \times h_u = 10,0 \times 4,5 = 45,0 \text{ m}^2$
- $S_{po} = 14,625 \text{ m}^2$
- $S_{po} / S_p \times 100 = 33\% \rightarrow p_o = 40\%$
- fire prevention distance- 5,2 m

-The west elevation

- $S_p = l \times h_u = 8,0 \times 5,6 = 44,8 \text{ m}^2$
- $S_{po} = 10,875 \text{ m}^2$
- $S_{po} / S_p \times 100 = 24\% \rightarrow p_o = 40\%$
- fire prevention distance- 4,5 m

-The east elevation

- $S_p = l \times h_u = 7,75 \times 5,5 = 42,625 \text{ m}^2$
- $S_{po} = 18,625 \text{ m}^2$
- $S_{po} / S_p \times 100 = 44\% \rightarrow p_o = 60\%$

- fire prevention distance- 6,2 m

See the situation plan. Design building does not interfere by its fire hazardous area in neighboring plots. It is not situated in hazardous area of other buildings. Fire prevention distances satisfy conditions.

## **J) Water for extinguishing**

External hydrants

-acc. ČSN 730873 there have to be mounted underground hydrants on the main pipeline DN min. 100mm, distance from the building must not be bigger than 150m

Internal hydrants

-acc. par. 4.4 b) ČSN 730873 internal hydrants are not demanded.

## **K) Access roads**

Building will be placed 10 m from a road so that fulfils requirements ČSN 73 0833, paragraph 4.4.1.

## **L) Fire extinguishers**

In accordance with enclosure 4 of Public note 23/2008 one powder extinguisher with fire ability 183B (powder extinguisher 6kg) will be placed inside a family house. Its position will be in accordance with Public note 246/2001.

## **M) Technical equipment evaluation**

-ventilation

-natural self-ventilation by windows

-heating, domestic hot water heating

-ensured by gas boiler Protherm PANTHER 12 KTO (3,5 - 12,6 kW) installed in the technical room.

-in the technical room there must not be installed other device which can produce reverse combustion ways

-combustion ways have to fulfill requirements of government regulation n.91/2010 about conditions of fire protection during usage of chimney and ČSN 73 4301-Residential building- Chimneys and smoke flue- design, implementation and connection of fuel appliances

## **N) Special requirements on the fire resistance of the constructions**

No special requirements.

## **O) Fire safety devices**

According to the Public notice 23/20008Sb. family house has to be equipped by autonomous fire detector and smoke detector.

Recommended placing- rooms number 1.10 and 2.19

## **P) Safety signs**

Movable fire extinguisher and main electric switch will be signed according to the ČSN ISO 3864, ČSN 010813 and government regulation NV 11/2002sb. warning protection signs and tables.

## **Q) Conclusion**

- project documentation solved new building of family house for five member family. Family house is designed like as low energy detached house with two-stories
- family house forms one fire sector, two-storey, that is classified into II.DFS
- design construction systems satisfy requirements of ČSN 73 0802 for II.DFS
- escape ways satisfy requirements of ČSN 73 0833
- family house does not interfere by its fire hazardous area into neighboring plots
- one powder extinguisher with fire ability 183B (powder extinguisher 6kg) will be place inside a family house
- family house has to be equipped by autonomous fire detector and smoke detector.
  - Recommended placing- rooms number 1.10 and 2.19
- for approval of building certificates will be submitted in accordance with appropriate Public notes and acts
- a part of FSR is a layout of situation with signed fire prevention distances

SITUATION OF FIRE FAFTY DISTANCES 1:200

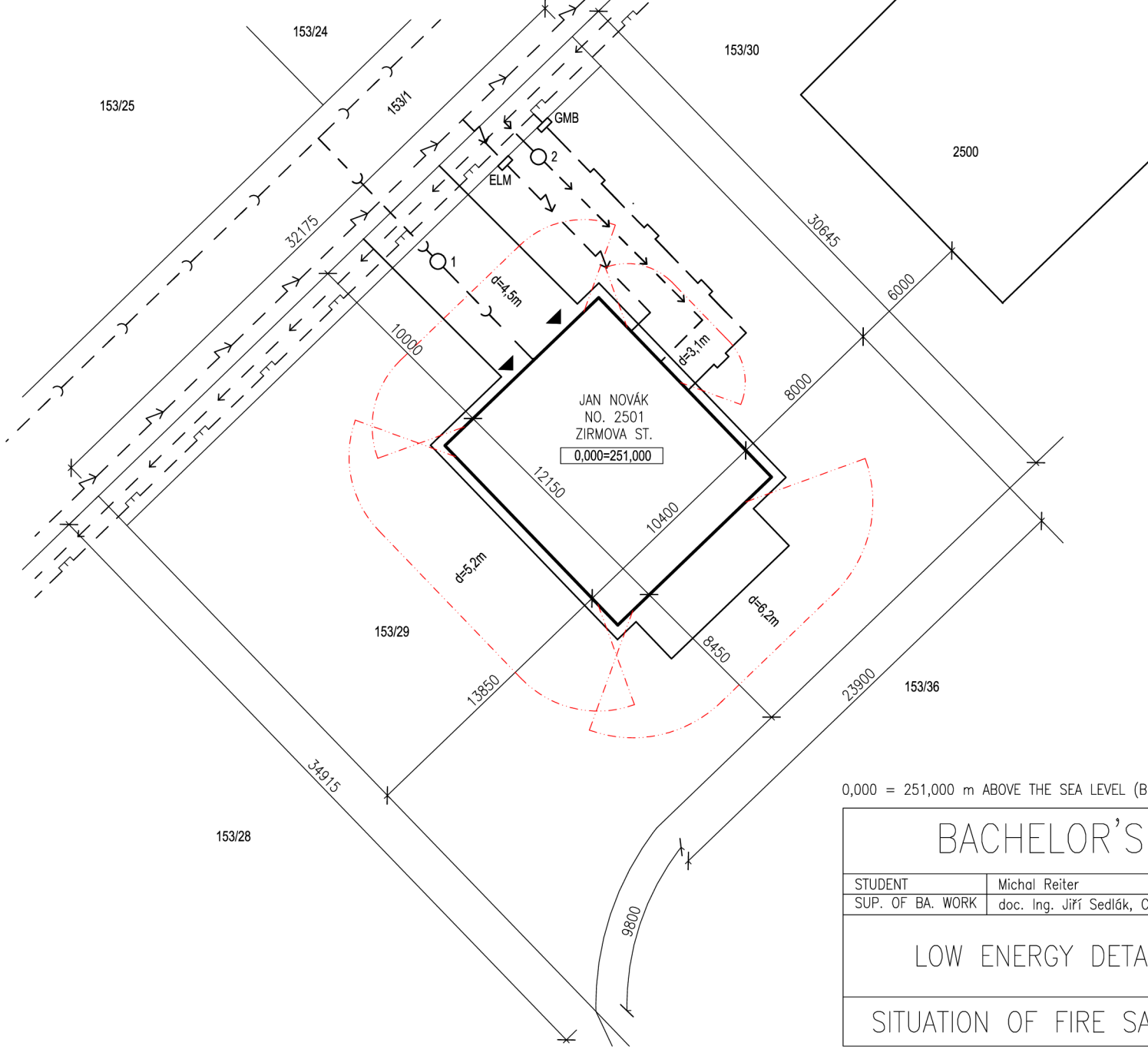

LEGEND OF THE OBJECTS

- NEWLY BUILT OBJECT
- PRESENT OBJECTS

LEGEND OF ENGINEERING NETWORKS

- EXISTING DISTRIBUTION OF LOW VOLTAGE
- PUBLIC WATER MAIN
- PUBLIC PIPELINE OF SANITARY SEWERAGE
- EXISTING DISTRIBUTION OF LP GASPIPELINE

LEGEND OF SERVICE PIPES

- ELECTRIC CONNECTION
- WATER PIPELINE CONNECTION-PE DN 32
- SEWERAGE SERVICE PIPE- PVC KG 150
- LP GASPIPELINE CONNECTION-PE 100 SDR11 DN 32

LEGEND OF SIGNS

- PLOT BOUNDARY
- 1 WATER GAUGING SHAFT WITH WATER METER AND MAIN WATER CLOSURE
- 2 CHECK SHAFT- RV SYSTEME, PVC DN 400
- ELM ELECTRIC METER BOX
- GMB GAS METER BOX- WITH GAS METER AND MAIN GAS CLOSURE
- CONTOUR LINE
- FIRE SAFETY DISTANCE

AREA OF THE PLOT 998,3 m<sup>2</sup>  
 BUILT-UP AREA 126,3 m<sup>2</sup>

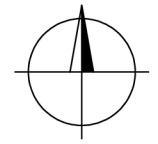

0,000 = 251,000 m ABOVE THE SEA LEVEL (Bpv)

BACHELOR'S THESIS

STUDENT Michal Reiter  
 SUP. OF BA. WORK doc. Ing. Jiří Sedláč, CSc



VUT V BRNĚ  
 FAKULTA STAVEBNÍ  
 VEVEŘÍ 331/95  
 602 00 Brno  
 TEL. 541 141 111  
 DEPARTMENT OF CIVIL ENGINEERING

LOW ENERGY DETACHED HOUSE

FORMAT 2 A4

DATE 5/2012

SITUATION OF FIRE SAFETY DISTANCES

SCALE 1:200  
 DRAWING NO. 2