



BRNO UNIVERSITY OF TECHNOLOGY

VYSOKÉ UČENÍ TECHNICKÉ V BRNĚ

FACULTY OF ELECTRICAL ENGINEERING AND COMMUNICATION

FAKULTA ELEKTROTECHNIKY
A KOMUNIKAČNÍCH TECHNOLOGIÍ

DEPARTMENT OF ELECTRICAL AND ELECTRONIC TECHNOLOGY

ÚSTAV ELEKTROTECHNOLOGIE

DESIGN OF A PHOTOVOLTAIC POWER SYSTEM WITH BATTERY STORAGE FOR HOUSEHOLD PURPOSES

NÁVRH FOTOVOLTAICKÉ ELEKTRÁRNY S BATERIOVÝM ÚLOŽIŠTĚM PRO DOMÁCNOST

MASTER'S THESIS

DIPLOMOVÁ PRÁCE

AUTHOR

AUTOR PRÁCE

Bc. Radek Polášek

SUPERVISOR

VEDOUCÍ PRÁCE

doc. Ing. Jiří Vaněk, Ph.D.

BRNO 2022

Master's Thesis

Master's study program **Electrical Manufacturing and Management**

Department of Electrical and Electronic Technology

Student: Bc. Radek Polášek

ID: 203160

**Year of
study:** 2

Academic year: 2021/22

TITLE OF THESIS:

Design of a photovoltaic power system with battery storage for household purposes

INSTRUCTION:

Learn about the principle of photovoltaic process and analyze and analyze the PV technologies used to produce PV cells. Develop the theory to include an analysis of battery storage technologies according to the parameters of each battery type. Focus on the evaluation of this market in the Czech Republic (advantages, subsidies, conditions, legislation). In the practical part of the thesis, propose a PV + battery storage solution for a household according to the specific task.

RECOMMENDED LITERATURE:

Podle pokynů vedoucího práce.

**Date of project
specification:** 7.2.2022

**Deadline for
submission:** 25.5.2022

Supervisor: doc. Ing. Jiří Vaněk, Ph.D.

doc. Ing. Petr Bača, Ph.D.
Chair of study program board

WARNING:

The author of the Master's Thesis claims that by creating this thesis he/she did not infringe the rights of third persons and the personal and/or property rights of third persons were not subjected to derogatory treatment. The author is fully aware of the legal consequences of an infringement of provisions as per Section 11 and following of Act No 121/2000 Coll. on copyright and rights related to copyright and on amendments to some other laws (the Copyright Act) in the wording of subsequent directives including the possible criminal consequences as resulting from provisions of Part 2, Chapter VI, Article 4 of Criminal Code 40/2009 Coll.

ABSTRACT

The aim of this thesis is to present the basics and functional principles of photovoltaics and photovoltaic systems, so that they can be later used design a photovoltaic energy system on a family house.

The first part of this thesis deals with the theoretical introduction of photovoltaics and the individual components needed to design a photovoltaic system. The second part of the thesis then deals with the design and simulation of several variants of a system with different setups. The first type of analyzed and designed system is the off-grid system, whose primary objective in this design variant is to completely cover the consumption of the household. Although the total annual consumption of the selected household is not that high, achieving a complete self-sufficiency requires a very significant investment in system equipment., beyond the conventional design. The main cause of this are the problematic periods of low solar radiation through the year, especially during winter. As a result, the design of an off-grid system proves inadequate to the vision of the owners, even after the consideration of possible alternative versions of it.

Alternative to an off-grid system is in our case a hybrid system which, unlike the first solution, also allows for connection to the grid to be supplemented by it during periods of low generation. After the introduction of hybrid system principles and analysis of possible financial subsidies, the individual hybrid system designs follow, each designed around a different focus point.

The first simulated design is one aimed at as low initial investment as possible. This variant is also utilizing a virtual battery tariff, which allows, thanks to generated surplus energy, for to draw electricity from the grid at a reasonable discount. After the financial analysis, the system proves to be a relatively cheap variant, however, the potential investment return is not that promising.

The second variant is intended as an imaginary middle ground between minimal and maximized approaches. it is composed of one fully covered roof area, with an adequate battery to support the modules. In addition, this system takes advantage of the sale of surplus generation on the market. Due to relatively high subsidy amount, combined with the surplus sale, the financial analysis of this system promises a return on investment during the first seven years of operation, with continually increasing positive numbers, when compared to the variant without a photovoltaic system.

The third system is aimed at maximizing the potential gain, while staying under 10 kWp of installed power. Downside of this approach is a higher acquisition cost, but the estimated return on investment is significantly higher than that of the previous systems. In the last part, a multi-criteria analysis was performed to determine the most suitable system variant, in accordance to the requirements of the selected property owners. The results of this analysis showed the third system variant to be the most suitable, with a share of 47.6%.

KEYWORDS

Photovoltaic system, solar panels, off-grid system, hybrid system, clean energy

ABSTRAKT

Cílem této práce je představit základy a funkční principy fotovoltaiky a fotovoltaických systémů, tak aby mohly být následně použity k návrhu fotovoltaického energetického systému na rodinném domě.

První část práce se zabývá právě teoretickým úvodem do tématu fotovoltaiky a představením jednotlivých komponentů, kterých je při návrhu fotovoltaického systému potřeba. Druhá část práce se poté zabývá designem a simulacemi fotovoltaických systémů v několika variantách a také režimech připojení. Nejprve se jedná o systém ostrovní, jehož primárním cílem je v tomto návrhu kompletní pokrytí spotřeby domácnosti. Ačkoliv úroveň spotřeby není pro vybranou domácnost nijak vysoká, dosažení kompletního pokrytí vyžaduje velmi značnou investici do vybavení systému, nad rámec běžného návrhu, zejména kvůli problematickým obdobím s nízkou úrovní slunečního záření. Ve výsledku se tedy návrh ostrovního systému ukazuje jako nedostatečný a to i po uvážení a rozboru jeho modifikovaných verzí.

Alternativou ostrovního systému je v našem případě systém hybridní, který narozdíl od první varianty řešení, umožňuje také připojení k síti a v době nízké generace energie, může být suplementován dodávkou právě z ní. Po představení principů hybridního systému a rozboru případných finančních dotací a prodeje přebytků, následují jednotlivé návrhy hybridních systémů, kde každý z nich má vlastní zaměření.

Jako první byl nasimulován návrh s co možná nejmenší pořizovací cenou, využívající zároveň tarifu virtuální baterie, která umožňuje díky přetokům levnější čerpání elektřiny ze sítě, když je tomu třeba. Po finanční analýze se systém sice ukázal jako levný, avšak potenciální výtěžek z něj a zhodnocení investice již nebylo tak slibné.

Druhá varianta hybridního systému byla zamýšlena jako pomyslný střed mezi minimálním a maximálním provedením. Jedná se o kompletní pokrytí jedné střešní plochy s adekvátní baterií. Takovýto systém navíc využívá prodeje přebytečné elektřiny na trhu. Díky vysoké úrovni dotace a také prodeji přebytků, slibuje finanční analýza tohoto systému relativně rychlou návratnost investice, která dále postupně roste v porovnání s variantou bez jakéhokoliv fotovoltaického systému.

Třetí systém byl zaměřen na maximální využití vhodných střešních ploch velikostního rozsahu pro mikrozdroje do 10 kWp instalovaného výkonu. Negativem takovéto varianty je vyšší pořizovací cena, avšak odhadovaná návratnost dosahuje značně vyšších úrovní než u předchozích systémů.

V poslední části byla provedena multikriteriální analýza s cílem určit nejvhodnější řešení systému, dle přesnějších požadavků majitelů daného rodinného domu. Vyhodnocení této analýzy ukázalo jako nejvhodnější třetí variantu, a to s podílem 47.6%.

KLÍČOVÁ SLOVA

Fotovoltaický systém, solární panely, ostrovní systém, hybridní systém, čistá energie

Author's Declaration

Author: Bc. Radek Polášek
Author's ID: 203160
Paper type: Master's Thesis
Academic year: 2021/22
Topic: Design of a photovoltaic power system with battery storage for household purposes

I declare that I have written this paper independently, under the guidance of the advisor and using exclusively the technical references and other sources of information cited in the paper and listed in the comprehensive bibliography at the end of the paper.

As the author, I furthermore declare that, with respect to the creation of this paper, I have not infringed any copyright or violated anyone's personal and/or ownership rights. In this context, I am fully aware of the consequences of breaking Regulation § 11 of the Copyright Act No. 121/2000 Coll. of the Czech Republic, as amended, and of any breach of rights related to intellectual property or introduced within amendments to relevant Acts such as the Intellectual Property Act or the Criminal Code, Act No. 40/2009 Coll. of the Czech Republic, Section 2, Head VI, Part 4.

Brno

.....
author's signature*

*The author signs only in the printed version.

POLÁŠEK, Radek. *Design of a photovoltaic power system with battery storage for household purposes*. Brno: Brno University of Technology, Faculty of Electrical Engineering and Communication, Department of Electrical and Electronic Technology, 2022, 98 p. Master's Thesis. Advised by doc. Ing. Jiří Vaněk, Ph.D.

ACKNOWLEDGEMENT

I would like to thank the supervisor of my thesis, doc. Ing. Jiří Vaněk, Ph.D. for his guidance and council over problematic aspects of the thesis.

Contents

List of Figures

List of Tables

1	Introduction	1
2	Photovoltaic phenomenon	2
2.1	Photovoltaic cell principle	2
3	Photovoltaic technologies	5
3.1	Mono-crystalline panels	5
3.2	Poly-crystalline panels	5
3.3	Thin-film solar panels	5
3.4	Efficiency and available solar panel technology	6
3.4.1	Comparison of available solar panel technology	6
3.4.2	Negative effects on efficiency	8
4	Photovoltaic system	9
4.1	Batteries	9
4.1.1	Lead-acid batteries	10
4.1.2	Lithium-ion batteries	10
4.1.3	Examples of available batteries	11
4.2	Inverters	12
4.2.1	Examples of available inverters	12
4.2.2	Different types of inverters - phases	13
4.2.3	Sizing factor	13
5	Assessment of available data	14
5.1	Legislative requirements for a PV system	17
5.2	Overview of available subsidies and financial support	18
5.3	Meteorological analysis of the chosen area	19
5.4	Disclaimer	20
5.5	Introduction to PVSOL	21
6	Designing a photovoltaic system	23
6.1	Safety of installation and operation	26
6.1.1	Disconnectors	26
6.1.2	Surge protectors	26
6.1.3	Electricity meters	26

7	Off-grid photovoltaic systems	27
7.1	PV system with full coverage of consumption	27
7.2	Financial analysis of full consumption coverage	30
7.3	Alternative off-grid approaches	32
7.3.1	PV system with load shedding	32
7.3.2	PV system for selected appliances	32
7.3.3	PV system with backup generator	33
8	Hybrid photovoltaic systems	41
8.1	Hybrid system subsidies	41
8.1.1	Requirements for NGSP 2021 subsidy eligibility	42
8.2	Hybrid inverters	43
8.3	Hybrid system prototype	44
8.4	Improving daytime efficiency of the PV system	53
8.5	Feeding electricity back to the grid	55
9	Available market prices	61
9.1	Roof installation prices	61
9.2	Battery prices	62
9.3	Inverter prices	63
9.4	Safety element prices	63
9.5	Cabling prices	64
10	Choosing the final variant of the system	65
10.1	Control element	65
10.2	Hybrid solution with minimal investment	66
10.2.1	System design	66
10.2.2	System analysis	68
10.2.3	Economic analysis	70
10.3	Balanced hybrid solution	72
10.3.1	System design	72
10.3.2	System analysis	73
10.3.3	Economic analysis	75
10.4	Hybrid solution with maximized gain	77
10.4.1	System design	77
10.4.2	System analysis	79
10.4.3	Economic analysis	81
11	Multi-criteria decision analysis	83

12 Conclusion	86
13 Rozšířený český abstrakt	88
Bibliography	91
Symbols and abbreviations	98

List of Figures

2.1	Atomic grid structure of silicon	2
2.2	Atomic grid structure of p and n-type semiconductors	3
3.1	Commonly used types of solar panels [3]	6
4.1	Simplified representation of a possible PV system structure	9
5.1	Yearly energy consumption of the household	14
5.2	Simulated monthly energy consumption	15
5.3	Changes in ČEZ electricity prices (2017-2022) [11]	16
5.4	Layout of suitable roof areas for photovoltaic panel installation	17
5.5	Estimated values of solar radiation over the area of Europe [16]	19
5.6	Monthly solar irradiation estimates	20
5.7	Function categories available in PV*SOL	21
6.1	Numbered representation of usable roof areas	23
6.2	Simulated shading on roof section 3	24
6.3	Simulated shading on roof section 4	25
6.4	Simulated shading on roof section 1	25
7.1	View of the proposed module coverage on both roof areas	27
7.2	Visualization of different energy values of the system	28
7.3	Energy flow diagram for a fully self sufficient off-grid system	29
7.4	Schema of an off-grid system with backup generator	33
7.5	Energy flow diagram of the backup generator system	34
7.6	Diagram of backup generator usage through the year	34
7.7	Diagram of backup generator with different batteries	36
7.8	Average price survey of selected fuel products (2016-2022) [22]	38
7.9	Generator usage and fuel costs per year	39
8.1	Overview of consumption coverage for the first iteration	45
8.2	Consumption coverage ratio of the first iteration	46
8.3	Overview of consumption coverage for the second iteration	46
8.4	Consumption coverage ratio of the second iteration	47
8.5	Energy flow diagram of the second hybrid iteration	48
8.6	Energy flow of selected elements (second hybrid iteration, July)	49
8.7	Energy flow of selected elements (27. 7., second hybrid iteration)	50
8.8	Energy flow of selected elements (26. 7., second hybrid iteration)	51
8.9	Energy flow of selected elements (second hybrid iteration, December)	52
8.10	Energy flow of selected elements (25. 12., second hybrid iteration)	53
8.11	Consumption diagram example (A) with ideal application of load shifting (B)	54
8.12	Daily market prices of electricity (EUR), as given by OTE	55

8.13	Monthly average feed-in price (2017 - early 2022)	56
8.14	Example of OTE daily market values (25. 1. 2022) [29]	59
8.15	OTE daily market values for buy and sell time-frames (February 2022) [29]	60
10.1	Module placement of the minimal investment variant	67
10.2	Structure diagram of the minimal investment variant	67
10.3	Energy flow diagram of the minimal investment variant	68
10.4	Estimated cash flow of the minimal investment variant	70
10.5	Cash flow comparison for the minimal investment variant	71
10.6	Module placement of the balanced variant	72
10.7	Structure diagram of the balanced variant	73
10.8	Energy flow diagram of the balanced variant	73
10.9	Estimated cash flow of the balanced variant	76
10.10	Cash flow comparison for the balanced variant	76
10.11	Module placement of the maximized gain variant	78
10.12	Structure diagram of the maximized gain variant	78
10.13	Energy flow diagram of the maximized gain variant	79
10.14	Estimated cash flow of the maximized gain variant	81
10.15	Cash flow comparison for the maximized gain variant	82
11.1	Hierarchical structure of the analysis	83

List of Tables

3.1	Examples of available solar panel range [36]	7
4.1	Examples of available battery range [36]	11
4.2	Examples of available inverter range [36]	12
6.1	Overview of available and simulated (July) roof data	24
7.1	Specifications of the full coverage example PV system	28
7.2	Specifications of the simulated system	31
7.3	Cost of the simulated system [36]	31
7.4	Specifications of the used generator	35
7.5	Generator usage data for different battery unit variants	37
7.6	Yearly generator consumption and costs of fuel	39
8.1	NGSP subsidy amount of subsection C.3 [21] - translated	41
8.2	Specifications of the first hybrid iteration	45
9.1	Example of prices for PV modules [36]	61
9.2	Price estimates of support structure components [36]	62
9.3	Price estimates of used inverters [36]	63
9.4	Price estimates of used safety elements [36]	64
9.5	Price estimates of cabling components [36]	64
10.1	Yearly cash flow without a PV system	65
10.2	Yearly cash flow of the minimal investment variant	69
10.3	Estimated initial investment of the minimal investment variant	69
10.4	Yearly cash flow of the balanced variant	74
10.5	Estimated initial investment for the balanced variant	75
10.6	Yearly cash flow of the maximized gain variant	80
10.7	Estimated initial investment for the maximized gain variant	80
11.1	Paired comparison table of the individual criteria	84
11.2	Paired comparison table of the individual variants	84

1 Introduction

Solar power represents increasingly more interesting option of power supply for modern households and many of them are already taking advantage of this environmentally friendly power source. For some it might be the perfect option if they want to keep the power production off the power grid and some might want to reduce their carbon footprint. Regardless of the particular reason, there are many advantages and possible reasons as to why a household would want to utilize solar power and it is always important to weight those advantages against all possible disadvantages when considering potential switch to a new supply of power.

In the first part of this thesis, we will go over the basic principles of solar power generation, the photovoltaic phenomenon. We will go over the individual parts of this phenomenon, its general applications and finally its usage in photovoltaic systems for households. The subsequent part covers the practical part of photovoltaic power generation, along with a direct example of a simulated off-grid and hybrid PV system installations, along with corresponding financial analyses and possible alternatives to consider.

Both the off-grid and hybrid system variants present their own advantages and disadvantages. Those are more expanded upon in their respective chapters of this thesis, along with financial analyses and simulated system results. These overviews of individual variants serve the purpose of identification and choice of the most suitable system variant, according to certain priorities. This will be accomplished by using a specific multi-criteria analysis method, taking into account different factors of a single goal, in accordance with wishes of the owners of selected property.

2 Photovoltaic phenomenon

In order to understand the working processes behind the photovoltaic systems, we need to delve into the problematic of photovoltaic effect itself. We will go over the basic principle of solar power generation and how can those principles be used in order to construct a fully functional photovoltaic power plant.

Photovoltaic effect in its basic form is when we utilize specialized cells: photovoltaic cells, in order to generate voltage. These cells can only generate if they are being hit by direct light, which of course means they need to be exposed to direct sunlight in order to function. The easiest way to explain the conversion of sunlight to electric power is to first take a closer look at the individual photovoltaic cells.

2.1 Photovoltaic cell principle

A typical photovoltaic panel consists of larger amount of photovoltaic cells. These cells are the individual units that convert the energy from sunlight into usable electricity. Sheer majority (up to 95%) of these photovoltaic cells is made using silicon [1]. Potentially the greatest attribute of silicon is its high available amount, as it is the second most abundant element present on Earth, where it makes up to around 27% of Earth's crust [2]. This fact and its valuable semiconductor properties make silicon the prime candidate for a photovoltaic cell base material. To better understand the phenomenon of light to power conversion, we should take a look at the atomic structure of silicon grid below:

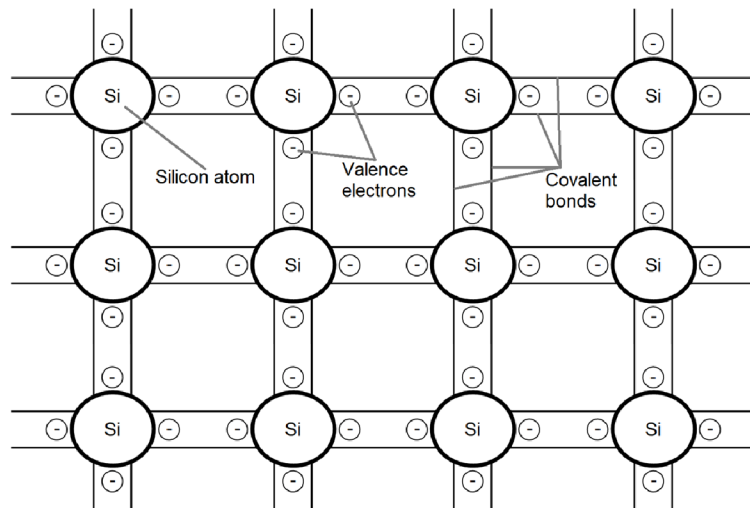

Fig. 2.1: Atomic grid structure of silicon

From the figure, we can see that the grid is composed of individual silicon atoms. These atoms are interconnected to each other by electrons from their outer-most orbit. Each silicon atom has four valence electrons that partake in covalent bonds. If we structure these silicon atoms into a grid, each of them will form a covalent bond with four other nearby silicon atoms and in the same way, four nearby silicon atoms will form a covalent bond with it, making each silicon atom to have a total of eight shared valence electrons. This is the basis of a silicon structure. The real potential of this structure comes with the replacement of a silicon atom with atoms that have a different number of valence electrons. For example, if we were to replace one silicon atom with an atom of boron (which has one less valence electron, making it a trivalent element), there would be one less shared electron in the grid. This creates a “hole” in the grid which allows nearby electrons to fill it, gaining a positive charge in the process. On the other hand, if we were to replace the silicon atom by a pentavalent element such as phosphorus, which has five valence electrons, there would suddenly be an additional free valence electron not being shared with any neighbour silicon atoms. Whether it is an extra electron or the absence of one, the crystal structure of silicon changes and it now has a majority charge carriers, making it either n or p-type semiconductor, based on what element was used to dope the structure.

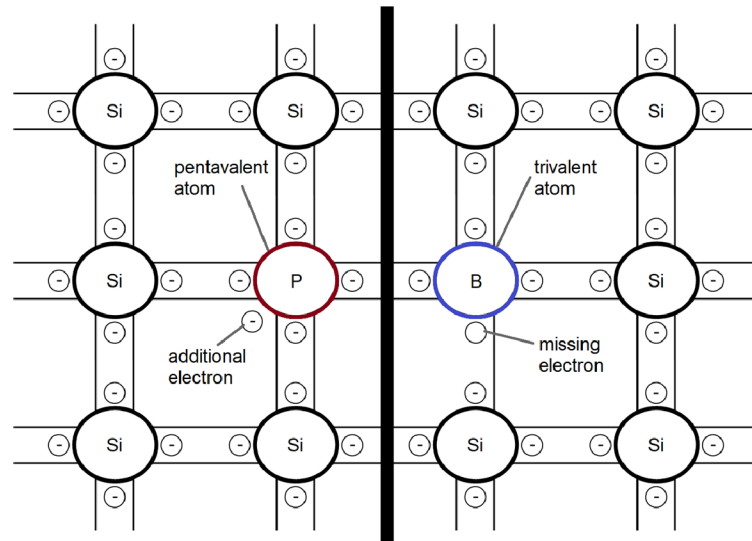

Fig. 2.2: Atomic grid structure of p and n-type semiconductors

If we were to join both of these semiconductor types together, we would create something called a p-n junction where the p-type structure obtains (accepts) electrons from the n-type structure. Similarly, the n-type structure accepts the holes from the p-type. As this process occurs a layer builds near the zone where the two

semiconductor types make contact. This layer is negatively charged on the p-type side of the contact and positively charged on the n-side. This is caused by the excess charge carriers on either side and the layer continues to increase in size. After a certain point, the charges can no longer pass through this layer to the opposite side of the junction. At this point we have an operational basis for a photovoltaic cell.

The beforehand mentioned p-n junction of semiconductor materials acts as the core of a photovoltaic cell. When the light strikes the cell, some of it is absorbed into the atomic structure, where the photons excite some of the valence electrons that form the covalent bonds between the silicon atoms. When this happens, the electrons can break from the bond, which results in a new electron and hole pair. If this happens in the n-type semiconductor side, the newly freed electron and hole start to move through the material, but are unable to cross the junction as there is the already mentioned layer blocking their way. Electrons get repelled on the n-side and holes are pulled to the p-side and are repelled afterwards. As the charge carriers cannot cross through the material, we can connect the two semiconductor structures with a wire. When we do, the excess trapped electrons start flowing through it from the n-side to the p-side, where they recombine with the trapped holes. This movement of electrons causes current to generate through the connecting wire.

3 Photovoltaic technologies

There are many different implementations of photovoltaic cells into systems, varying by circumstances of use or by the different ways of silicon processing. We can begin by distinguishing between the two main types of solar panels: mono- and poly-crystalline.

3.1 Mono-crystalline panels

As the name implies, this type of solar panels is primarily constructed by single crystal silicon photovoltaic cells. The cells' structure consists of a single silicon crystal that has been sliced into individual layers, also called wafers. This approach ensures better flow of electricity and as such provides more efficient conversion. More efficiency also means that solar panels constructed this way will inevitably be less affordable than the next category.

3.2 Poly-crystalline panels

Unlike their mono-crystalline competition, these solar panels are formed by cells containing multiple silicon crystals. This approach is generally cheaper to implement and allows for the resulting solar panels to be more affordable at the cost of reduction in their efficiency. This does not necessarily mean that they are inferior to the mono-crystalline variety as the drop in their efficiency is not as formidable and more and more poly-crystalline variants are nowadays able to compete with their mono-crystalline counterparts.

3.3 Thin-film solar panels

Even more affordable alternative than that of poly-crystalline panels, are the thin-film panels. These panels consist of a thin sheet of photovoltaic material on top of a substrate that grants the final product flexibility. The material choice for thin-film panels can also be silicon, but unlike the previous two variants, this time it is in its amorphous form, meaning it does not form crystals. Different types of photovoltaic material can alternatively be used. As the lower price of these panels already indicates, they are significantly less efficient when compared to mono-crystalline panels and still less efficient than the poly-crystalline variant.



Fig. 3.1: Commonly used types of solar panels [3]

3.4 Efficiency and available solar panel technology

While mono-crystalline solar panels boast the highest efficiency, it does not always mean that they should be the preferred choice while designing photovoltaic energy system. Various other factors also need to be taken into account, such as the price and the resulting ratio of available power output. While considering the previously mentioned types of available solar panel technologies, we can compare between their particular representatives on the local market.

3.4.1 Comparison of available solar panel technology

From the most efficient, to the least, different types of solar cells have the largest impact on final efficiency of a solar panel. For example, mono-crystalline power cells have the highest efficiency of the basic three types of solar cells, reaching up to around 20% of efficiency, mainly thanks to their single silicon crystal structure. Poly-crystalline solar panels have noticeably lower degree of efficiency with the better examples reaching around 16% efficiency [4]. Lastly, thin-film solar panels achieve the lowest degree of efficiency of up to around 17% in the field and non-laboratory settings [5] which alone does put them on par with poly-crystalline panels, but combined with their larger requirement for space in order for them to compete with the other variants, it usually means that they are not the ideal candidates for a home oriented photovoltaic energy system.

Customers in Czech Republic have wide range of options when considering a purchase of the right type of solar panel. For the next example, we will be considering solar panels available from Czech Republic retailers or alternatively those located inside of European Union, as it removes possible inconveniences with complicated shipping among other things. We can see some of the available options along with their specifications in the following table:

Tab. 3.1: Examples of available solar panel range [36]

Manufacturer	Module Denotation	Type	Max. Power	dimensions (m)	Price (CZK)	efficiency*
LONGI	LR4-60HPH-360W	Mono-Crystalline	360 W	1.776 x 1.052 x 0.035	4 720	19.3%
CanadianSolar	CS3K-305Wp	Mono-Crystalline	305 W	1.672 x 0.992 x 0.035	3 800	18.36%
AmeriSolar	AS-6M30-BLACK-320Wp	Mono-Crystalline	320 W	1.64 x 0.992 x 0.035	3 290	19.67%
DAH Solar	HCM60X9-330W	Mono-Crystalline	330 W	1.686 x 1.002 x 0.035	3 790	19.53%
JA SOLAR	JAM60S20-390/MR	Mono-Crystalline	390 W	1.769 x 1.052 x 0.035	4 290	21%
AEG	AS-M1443-H-450	Mono-Crystalline	450 W	2.108 x 1.048 x 0.035	5 069	20.4%
Victron Energy	SPP041751200	Poly-crystalline	175 W	1.485 x 0.668 x 0.03	3 420	17.64% (calc)
AmeriSolar	AS-6P30-285Wp	Poly-crystalline	285 W	1.64 x 0.992 x 0.035	2 890	17.52%
Einnova Solarline	ESP 285	Poly-crystalline	285 W	1.64 x 0.992 x 0.035	2 835	17.5%
Coulee	CL105P6-36	Poly-crystalline	105 W	1 x 0.67 x 0.03	2 563	15.67% (calc)
DAH Solar	DHP60-280W	Poly-crystalline	280 W	1.650 x 0.991 x 0.035	3 300	17.12%
AVANCIS	PowerMax3.5 Smart 145	Thin-film	145 W	1.587 x 0.664 x 0.037	3 690	13.8%
Solar Frontier	SF165-S	Thin-film	165 W	1.257 x 0.977 x 0.035	5 128	13.4%

From the table, we can see most of the vital information about individual available solar panels, along with their efficiency. The efficiency values were taken from the promotional materials of the individual panel’s manufacturers, but if they were not available or incomplete for any reason, we could use the following equation to obtain the calculated value of module efficiency:

$$\eta = \frac{P_M}{A * 1000} \tag{3.1}$$

This is a commonly used equation for module efficiency; the calculation is based on maximum power output of the photovoltaic module (PM), which is divided by a two part denominator. First part consists of total area of the photovoltaic module in square meters (A) and the second part represents the light radiation at standard test conditions, also called STC, which is 1000 W/m² [6]. This equation’s results were similar to already provided efficiency values, with a deviation of around 0.03%.

If we take a look at the values from the previous table (see table 3.1), we can see that the examples of available solar panels achieve roughly the expected efficiency,

given their type. Mono-crystalline solar panels are in the range of 18-21% efficiency and as we already know, they should be the most efficient of the three discussed module types. Similarly, the poly-crystalline modules reach up to around 17% efficiency range, with some nearing the efficiency of mono-crystalline modules, with difference of less than 1%. The thin-film solar panels seem to be under their expected values of field efficiency and the table also contains less examples of this type of module, due to their general lack of presence on the Czech photovoltaic market, combined with their impracticality for a household photovoltaic power system.

3.4.2 Negative effects on efficiency

When considering photovoltaic panel efficiency, we need to take into account all the external environmental effects, affecting the panel. Spanning from temperature, through humidity, to shading, there is a wide list of elements that affect the efficiency in the field and as such, we will not always be able to reach the most optimal efficiency percentage or the theoretical laboratory efficiency levels.

One of the most prominent negative effects on solar panel output is the shading. Partial coverage of the available sunlight can severely reduce the output of any solar panel, which is why we need to consider possible shading sources in an area where we aim to set up our panels. Final impact of shading generated current of a PV panel may vary case by case. General research shows that with increasing shade profile, the value of generated current drops quite rapidly. With around 50% shading, the current output of a single PV cell decreases by more than 30%. Shading tests of entire PV modules then deliver roughly similar results as with a single cell [7].

Among some of the other phenomena that directly affect efficiency can be humidity. It was shown that humidity affects both current in the PV panel, most of all. By testing under increasing humidity levels from 25-50%, the current values slowly decreased along with voltage levels, lowering overall power production by 15-30% [8]. It is therefore important to consider the area's overall precipitation and humidity among other outer environmental calculations before further steps towards our own photovoltaic system.

4 Photovoltaic system

If we are to realize a photovoltaic power system, we require several more components in order for it to be fully functional. For example, a suitable storage for the generated energy can be implemented, for when the weather or any other exterior conditions prevent the connected photovoltaic panels from generating. In addition we also require an inverter. If we want to use the energy, generated by the photovoltaic modules, we need to convert the DC output that we get, into an AC that can be supplied to any load connected to the system. Basic schema of how a photovoltaic system with a battery would be structured can be seen in the following picture:

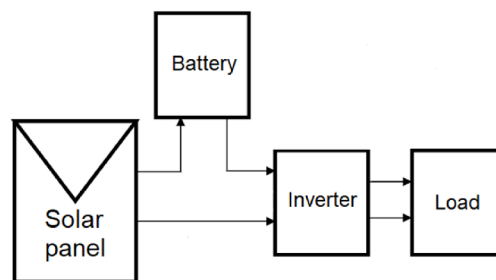

Fig. 4.1: Simplified representation of a possible PV system structure

We have already discussed the photovoltaic panels that provide energy for the system, now we will go over the other two important elements, battery and inverter, discuss their full function in the system as well as go over a list of available examples.

4.1 Batteries

One of the vital components of photovoltaic power system can be batteries. They store the energy that gets produced during the day and make it available for when we require it later. If we wanted to, for example, make use of our generated energy during the night, when the solar panels are not generating, without a battery in our PV system that would simply not be possible. There are two main types of batteries to consider as they are the most used for this type of installation. Each has its own distinct characteristics and principle of operation. When comparing the available market options, we will mainly be interested in some of the specifications, such as the type of the battery, its capacity, price and additionally, the service life of each battery, as they are on the more expensive side of PV system components; this parameter serves an important purpose.

4.1.1 Lead-acid batteries

The first type – lead-acid batteries- has been in general use for a longer period of time. Their comparatively lower cost to other used battery types makes them one of the dominant types on the market when it comes to PV system use.

The working principle is based on multiple pairs of lead and lead oxide plates that are connected together in series. These plate pairs are surrounded by electrolyte (diluted sulphuric acid). There is a flow of current between the two plates as the lead oxide loses electrons and the lead plate gains them. When the battery is charging, the potential difference exists between the two plates. Lead plate gives off electrons, while the lead oxide plate accepts electrons from the electrolyte.

This type of battery provides us with an easier to afford energy storage solution. Their main disadvantage for this type of installation would be their comparatively shorter lifespan. As with a PV system, we would expect quite frequent charge/discharge of the batteries, which would slowly degrade them over time and they would no longer be suitable for operation after several hundred of charge/discharge cycles.

4.1.2 Lithium-ion batteries

The newer type of energy storage offer considerably longer lifespan than their lead-acid counterpart. The seemingly negative aspect is their purchase price, which may seem considerably higher compared to the lead-acid batteries, but their degree of efficiency along with the prolonged lifespan make a big difference.

These batteries also consist of several main parts, namely anode, which is most commonly graphite, a lithium oxide cathode and electrolyte, along with a separating medium in between. During the discharging process, lithium atoms give off electrons and become positive lithium ions. These ions pass the separating medium and travel to the cathode to be recombined with electrons. The earlier given-off electrons travel through the external circuit (generated flow of current) to the cathode where they again recombine with lithium ions. When charging, the process goes in reverse, initiated by the solar panel. Lithium atoms give off the electrons again and pass the separating medium barrier, only to recombine with the given-off electrons at anode where they join the graphite structure, before the process of discharging begins anew.

As we already mentioned, this process does not degrade the battery as much as would be the case in lead-acid batteries. In addition to their low maintenance requirements, this makes the Li-ion batteries a more ideal candidate for a PV system.

Tab. 4.1: Examples of available battery range [36]

Manufacturer	model Denotation	Type	Voltage (V)	Capacity (Ah)	Dimensions (mm)	Price (CZK)	Service life (years) / (cycles)
Banner batteries	Energy Bull 230 – 968 01	Pb-Ac	12	230	517x273x240	8 490	-
Victron Energy	GEL - 220 Ah	Pb-Ac	12	220	522x238x240	15 131	7 – 10 years
Hoppecke	200Ah solar.bloc	Pb-Ac	6	200	242x170x275	15 091	10 – 12 years
ROLLS	4 CS 17P	Pb-Ac	6	733	365x210x464	23 448	3700 cycles
CS POWER	HTL 12-250	Pb-Ac	12	250	520x268x203	14 038	15 years
Victron Energy	LFP-BMS range	Li-ion	12.8	60-300	-	22 757 – 90 331	5000 cycles
PYLONTECH	US2000B Plus – 2.4KWh	Li-ion	48	50	440x410x89	27 900	6000 cycles
BMZ	Li-Ion 48V 121Ah 6.7kWh ESS 7.0	Li-ion	48	121	638x421x487	105 570	5000 cycles
Renogy	Smart LiFePO 12.8V/100Ah	Li-ion	12.8	100	289x172x187,5	19 990	4000 cycles
TESLA	Powerwall	Li-ion	120/240 AC	14 kWh	1150x755x147	*	10 years warranty

*) The price of Tesla Powerwall is currently not determined by the distributor in the Czech Republic

4.1.3 Examples of available batteries

If we take a look at the table above (See table 4.1) we can inspect the available range of solar batteries on the Czech market. There is a wide variety of available options that differ in parameter and price range. Some of the important parameters to pay attention to, when designing a home PV system, are the voltage and capacity of the battery as they will be co-dependent with other parts of our system. The other important aspect is naturally the price range of these batteries.

As we can also observe, the Tesla Powerwall battery unit is somewhat of an outlier among the other table entries. It is designed as large energy storage for households, larger than typical solar batteries and thus should exceed other available entries in capacity, but also in its price. The distributor has yet to determine its availability and pricing in the Czech Republic, but according to its specifications and its price in regions where it is already available, we can assume it is not an automatic inclusion to every household PV system.

4.2 Inverters

As the current generated by the photovoltaic cells is a direct current, meaning it can't directly power our appliances that require alternating current. For that reason, we require an inverter in our system, connected to the output of our photovoltaic modules in a feasible manner.

Photovoltaic system inverters also utilize a function called Maximum power point tracking (MPPT), which is a widely used control technique to extract maximum power available from the solar cells in a photovoltaic system. Due to the load and operating characteristics of the photovoltaic cells not matching, we do not always fully utilize the power provided by the PV cells, which is exactly the purpose of MPPT, which adjusts the terminal voltage of solar panels to extract maximum power [9].

Many of the available inverters also offer wide variety of additional features, mainly for protection and safety of use purposes, such as reverse polarity protection, which protects the inverter from damage should the polarity of the power supply be reverted; surge protection that protects the device from high voltage spikes; short circuit protection, and many other beneficial features.

4.2.1 Examples of available inverters

Examples of available inverters vary drastically in their parameters, such as different input voltages that are directly related to the type of batteries used in the PV system. If we are for example using 6 volt DC batteries in connection with a 12 volt DC/AC inverter, we would need to connect two of those batteries in a series in order to increase their voltage to match the inverter's input voltage. Optionally, we can also connect batteries in parallel to combine their capacity for a longer total supply time. The following table provides an overview of some of the locally available inverters suitable for PV systems:

Tab. 4.2: Examples of available inverter range [36]

Manufacturer	model Denotation	Voltage (V)	Power (W)	Peak power (W)	dimensions (mm)	Price (CZK)
CARSPA	CAR1K	12/24	1 000	2 000	273x208x77	2 257
CARSPA	CAR3K	12/24	3 000	6 000	420x230x108	6 726
Victron Energy	Phoenix VE DIRECT 500VA - 24V	24	400	900	86x172x275	4 814
Victron Energy	Phoenix VE DIRECT 1200VA - 24V	24	1 000	2 200	117x232x327	11 597
EPEVER	IP1000-12	12	800	1 600	299x232x99	4 048

The range of inverters available to us differs mostly in the output power and peak power, which will be mainly dependent on the requirements we set for our home PV system. We also need to make sure that we have the appropriate combination of batteries and inverter, so that their voltages match.

4.2.2 Different types of inverters - phases

The range of generally available inverters can further be split into two categories: three-phase inverters and single-phase inverters. This denotes the principle of operation for given inverter. As implied by the designation, three phase inverters change the DC input from the PV modules into a three-phase AC output, where the single-phase inverters convert the input to an output across a single phase. The important distinction is then also in the connected AC cabling, where a three-phase system consists of the three individual phases and a neutral wire, where single-phase system utilizes one phase wire and a neutral wire.

As the wiring in the later mentioned property (which will be the main subject of this thesis) utilizes a three-phase wiring, our primary goal will be to fit the proposed systems with three-phase inverters in order to minimize possible complications and need for modifications.

4.2.3 Sizing factor

Sizing factor represents additional attribute of inverters. It is based on the size ratio of the power of installed PV modules and inverter itself. The optimal value of this sizing factor can vary, depending on several factors, such as meteorological circumstances, or inverter and installation characteristics [10]. Some of the reasoning behind down-sizing an inverter could be the real operating conditions that very rarely match the ideal and having a slightly down-sized inverter makes it operate closer (in respect to the sizing factor) to the actual working conditions of the installation. Additionally, economic factors can also play a role in the decision making, where the financial benefit of the lower investment option can outweigh the potential benefits of a more balanced sizing factor, despite the risk of minor energy losses [10].

5 Assessment of available data

In the second part of this thesis, theoretical knowledge from previous chapters will be applied in order to design a functional photovoltaic system for a household. For the purpose of this exact design, a house has been chosen and all the oncoming processes will be implemented with that same building in mind. The chosen house is located in the Moravian-Silesian Region in a small village of Soběšovice. It is a two person household built on a larger area of land and the owners would welcome achieving more self-sufficiency, as they are already experimenting with it to some degree.

Firstly, we can take a look at the values of energy consumption of the household dating back several years. This will help us to better determine the details of possible photovoltaic installations.

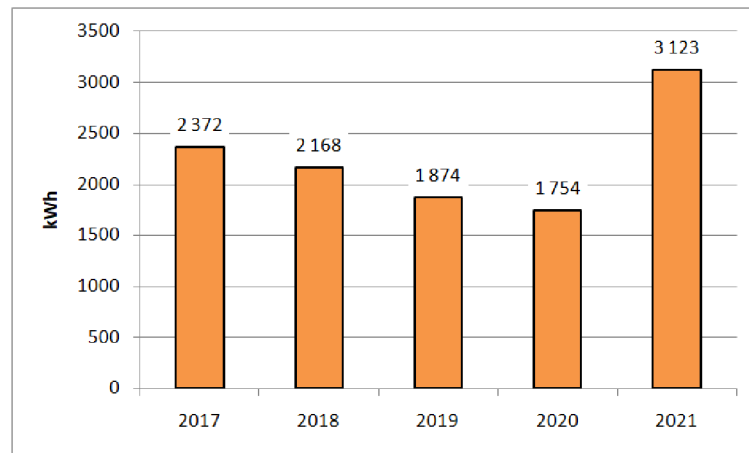

Fig. 5.1: Yearly energy consumption of the household

The above figure represents the energy consumption, measured yearly in July for the previous year, with some degree of variance. This means that for example the data from 2017 contain measured values for the interval between 3. 8. 2016 and 24.7. 2017. Thus, some variance is present, but in the larger, yearly scale, the data is sufficiently accurate. What we can observe at the first glance, is the nearly twofold increase of energy consumption in the last measured year, 2021. There are several factors affecting this steep consumption rise. As the owners explained, some of which include unforeseen medical conditions that required installation of several new electrical appliances and their frequent usage and also the more isolated living conditions that were caused by the Corona virus pandemic. Both of these major factors should now slowly return to normal, as should the assumed yearly consumption for oncoming years, with values similar to those several years back. For the purpose

of simulating a characteristic of assumed monthly energy consumption, we are going to use a mean value of the available yearly consumption data. This should provide us with the most accurately simulated numbers. Additionally, due to the available consumption data records not being measured in monthly intervals, we cannot with utmost certainty predict individual rises and decreases in consumption based on winter or summer influences. We can however assume that there will not be any significant deviations in those periods, as the household does not have air conditioning or other similarly demanding appliances that would cause major inclines during summer or during winter. We can see the simulated data of consumption on the graph below:

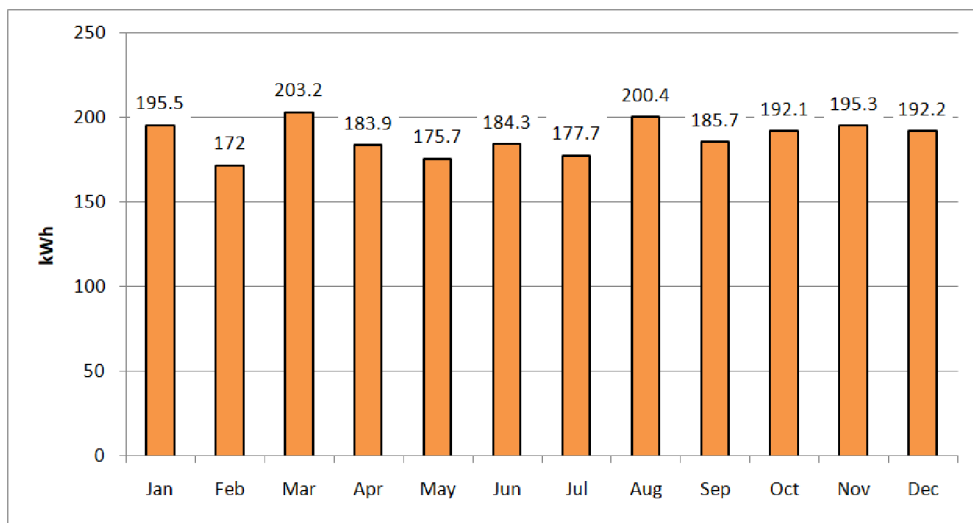

Fig. 5.2: Simulated monthly energy consumption

Simulating of monthly energy consumption will provide us with the necessary data to consider and design the photovoltaic system around. For example, we can obtain the maximum value of load peak power, which is crucial for selecting the appropriate types and quantities of photovoltaic modules.

With the yearly average consumption determined, there is still the question of the cost. Using the data made available by the used energy provider, ČEZ, we can put together a timeline of accurate costs per kWh up to the current year. During this assessment, three-year contract data will be evaluated as it is the current signed contract of the household. This might however change in the near future, as it was recently made unavailable for future signing and the provider only offers one-year contracts now [11]. Taking at the earliest available documentation, which contains electricity prices valid since the beginning of the year 2017 (later naturally invalidated by newer price list entries), we are able to establish certain base points

of the electricity pricing. It is also important to note, that the household currently remains under the D02d distribution rate, as per the ČEZ price list, which does not distinguish between high and low tariff prices and prices per kWh are therefore equal, no matter the hour of the day.

Calculating the price per kWh requires us to take into account the individual prices of delivery, distribution, tax and distribution service charges. These components make up the total electricity price per MWh (including the taxes, but excluding payment for reserved power according to the circuit breaker) that can then be converted to price per kWh.

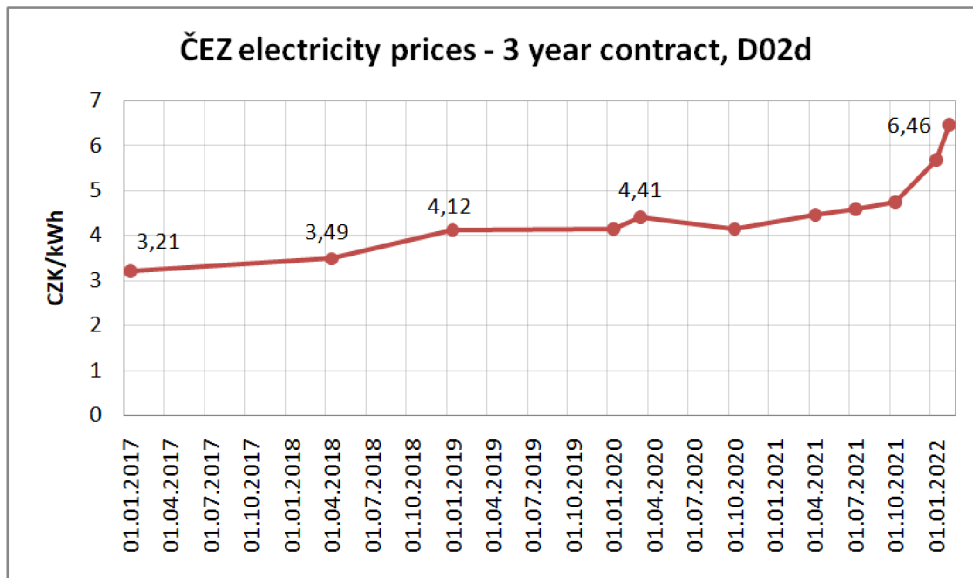

Fig. 5.3: Changes in ČEZ electricity prices (2017-2022) [11]

The above figure helps to demonstrate the steady increase in the price of electricity. The latest available contract (1. 2. 2022) and its price per MWh show almost 77 % increase compared to the earliest one from 2017. This might not directly applicable for the first system designs as they will be those of the fully self-sufficient off-grid variant, but the data will be used for and will directly affect the hybrid system part of this thesis as it will help to determine the best degree of balance between the size of the system and its overall efficiency.

Another important factor is the actual possible location for the photovoltaic panels. In this particular case, we have several roof areas available for consideration. As the building is located in the Northern Hemisphere, most ideal part of the roof would be one that is facing the south side, as that would in theory ensure the highest possible energy production.

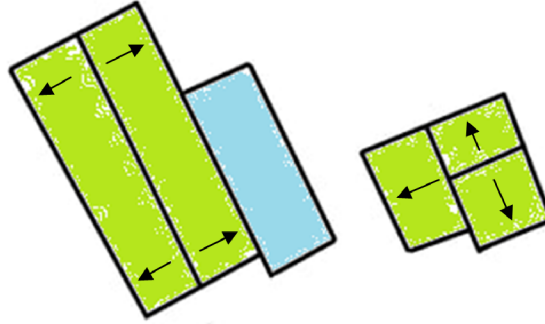

Fig. 5.4: Layout of suitable roof areas for photovoltaic panel installation

The figure above represents the actual layout of buildings with suitable roofs, with green areas representing sloped roofs and blue horizontal roofs. Slope orientation of each individual roof part is then represented with an arrow pointing in the direction of the slope. As we are able to see, unfortunately none of the available areas are directly facing south, but there are several options facing south to some degree. Those roof areas should have the most sunlight exposure through the day. There are of course other aspects that affect the optimal location for the installation of photovoltaic panels, such as shading, over which we will go in the simulation part of the analysis.

5.1 Legislative requirements for a PV system

Installing a photovoltaic system on a property is a process that is subject to several requirements. Most of these are set by the government under the current wording of laws. The important distinction to make at the beginning is the size of our proposed system, as that will have the most impact on what requirements are to be followed. Under the Decree No. 16/2016 Coll. (On the conditions of connecting to the electrical power system) [12], and under the Act No. 458/2000 Coll. (The Energy Act) [13], the term and definitions of micro-sources are defined and specified. Following the definitions, micro-source is (for our purposes) a PV system with installed power of less than or equal to 10 kW. If a system is a micro-source, it benefits from simplified conditions on connecting to the grid. Under § 16, section 2. of the Decree No. 16/2016 Coll. [12], the conditions of such connection are namely: A submission of an application for contract with the grid operator, and technical solution to prevent overflows into the network.

Should the installed power of the system exceed the limit of 10 kW, simplified conditions of connection no longer apply and instead the applicant is to subject to § 3, sections 1, 3 and 4. of the Decree No. 16/2016 Coll. [12]. This mainly entails

the need for a conducted connectivity study, under § 6 and § 7 of the Decree No. 16/2016 Coll. [12].

Given several determining factors, such as the available roof areas (see chapter 6) and preferred lower initial cost of the system, installed power under 10 kW will very likely be the desired solution.

5.2 Overview of available subsidies and financial support

Photovoltaic systems often go hand in hand with various available grants, allowing applicants to submit a request for financial help. Such is also the case the Czech Republic, where at the moment (Fall of 2021) a new program, called “New Green Savings Programme” (Nová Zelená Úsporám - NGSP 2021) started accepting requests for subsidies connected to energy savings for households. Photovoltaic system installations fall under that category and as such, it would be our primary candidate to financially help the project. Unfortunately, under the guidelines of application, off-grid systems are only eligible for subsidy, if the household in question is not itself connected to the grid. As that is not the case for the selected property, it will not be eligible to apply for this particular subsidy under the circumstances of the first several system variants. However, it will be largely important when considering a hybrid system with batteries and will therefore be further discussed during that part of the thesis.

Another feasible type of financial support to consider was, until recently, the Green Bonus support. It was a way for Czech Republic to support the usage of renewable sources for energy production. It is defined under the Act No. 165/2012 Coll. (The act on supported energy sources and on amendment to some laws) [14]. The specifics of the Green Bonus and its requirements are further defined under § 9 of the same Act and specify the sizing requirements and type of financial support to be received, should the possible (in our case) photovoltaic system qualify. The financial support. The obligation to provide this financial support falls on the market operator, who has to (depending on the conditions defined under the previously mentioned Act), upon proper application, pay out the set amount to the applicant in one of the available modes, as per § 9, section 3 of the Act No. 165/2012 Sb [14]. Unfortunately this would only apply for already operating PV systems and can not be applied on new systems. On 29 September 2021, the Energy Regulatory Office (ERO) issued a price decision No. 6/2021 [15]. This decision was based on, at the time in effect, Act No. 165/2012 Coll., on supported energy sources, and not on its subsequent amendment. Therefore it currently consists of (among other things) the

Green Bonus financial support that can not be utilized.

The remaining option is a feed-in method of financial support. These vary, depending on the given energy supplier, and will be more expanded upon during the hybrid system part of the thesis.

5.3 Meteorological analysis of the chosen area

One of the important conditions to pay attention to, while considering any form of PV system are the common local climate conditions in the considered area. Important conditions to pay attention to are mainly irradiation levels and average temperature through the year. Considering these and additional factors that will be discussed later is vital to determining if the chosen location is (and to what degree) suitable for a PV system installation.

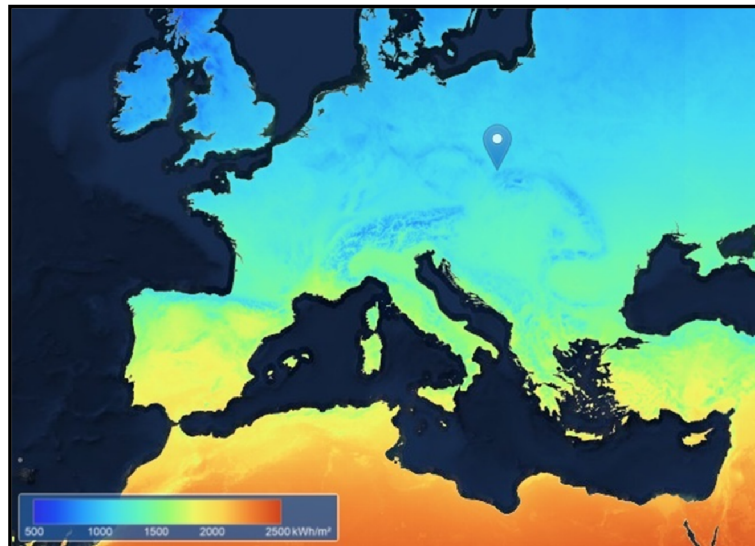

Fig. 5.5: Estimated values of solar radiation over the area of Europe [16]

As is visible from the picture above, the solar radiation levels are not as favourable in the chosen area of Czech Republic as they could be in more southern regions. This does not necessarily mean that a PV system set up in this area is bound to not be worth the investment, as the estimated values are still within acceptable limits and there is a multitude of other important factors that have even larger influence on the success of such project.

Next, monthly values of solar radiation can be obtained. From those, we can see the repeating yearly trend of solar irradiation levels, with slight variations during the peak radiation times.

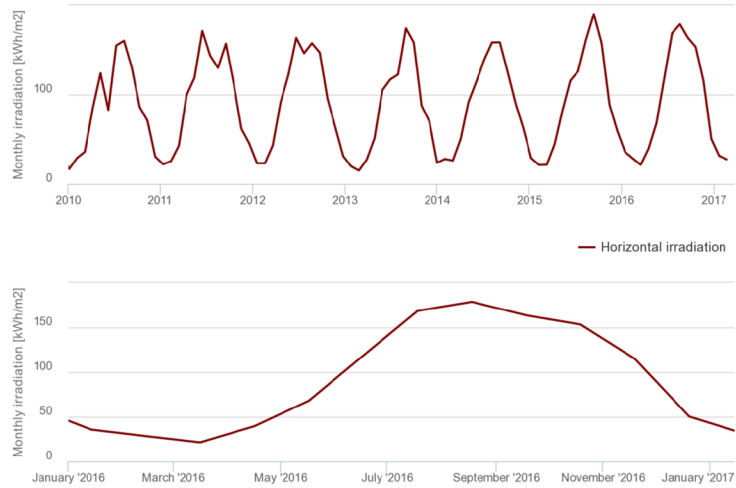

Fig. 5.6: Monthly solar irradiation estimates

As can be seen from the two previous charts, solar irradiation highly varies during the year, reaching peak values during the summer months. During this time, installed photovoltaic panels (depending on the size of the final installation) should provide enough energy to sufficiently support the connected household appliances. Problems will most likely arise during the months of low irradiance, such as during winter. During which, the panels will very likely struggle to provide sufficient energy and will therefore need to be supplemented by substantial quantity of battery units, in order to be able to fully cover the winter consumption curve (when considering an off-grid system), or supply electricity from the grid (when considering a grid-connected system). This will inevitably raise both the acquisition cost of the system as well as additional expenses during the lifespan of the system. Given this thought, fully self sufficient off-grid system is likely (in most cases) not the ideal route to undertake for a household of this type. Regardless, simulations will still be carried out to serve as a benchmark for future alternatives and system variations. This way we can compare between individual iterations from both economical and environmental points of view.

5.4 Disclaimer

For the sake of this particular simulation, several adjustments were made to the actual model of the property. These changes mostly include omitting details and construction elements that would not have a direct impact on the simulation results, or alternatively geographical elements that can be altered or disregarded. Among the first noticeable omitted elements would be the before mentioned building elements, such as alcoves, small objects and passages. As these elements are all under the

roof level of the buildings, the negative effect they could present to the photovoltaic modules in forms of, for example shading, are nonexistent and as such, can be excluded from the 3D model. Additionally, several trees rising above the roof level are located in the area near the buildings, which could lead to negative shading in some parts of the roof. However, the owner is willing and also planning to get rid of those trees, as they are becoming unpleasantly tall, and could become dangerous to nearby transmission lines if left unattended. Therefore, these trees can be cut out of the equation and are not going to pose a problem during the simulation.

5.5 Introduction to PVSOL

For the purpose of all of the simulation work and following system analysis, software called PV*SOL will be used. It is software that specialises in designed and simulation of photovoltaic systems, their construction, performance and financial analysis. It is an optimal tool for a photovoltaic system project design with many additional features at its disposal.

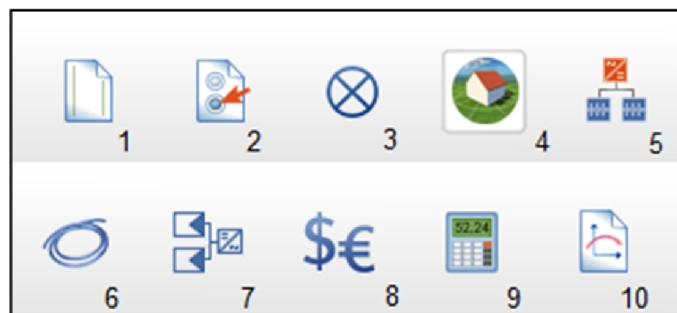

Fig. 5.7: Function categories available in PV*SOL

The above picture shows all of the available categories necessary to create a complete project. We can briefly go over each one of these to better understand all of the following parts of the analysis.

1. Project Data – Information about the customer and the project can be entered here for future reference and documentation.
2. System Type, Climate and Grid – First significantly important category determines type of the system we will be designing (whether it is a grid-connected or an off-grid system, etc.), the climate information based on location of the

project site, and, if a grid-connected system is being designed, the grid information is also entered here, such as the grid voltage or the number of phases.

3. Consumption – This category allows us to set up different load profiles for the project and calculate yearly energy consumption.
4. 3D Design / PV Modules+Inverters – This part of the project changes depending on whether we are working with a three dimensional design of the project site or just raw data with a two dimensional layout of the photovoltaic modules, in which case, we must also provide the data for our selected inverters. In the 3D design category, model of the site is fitted out with modules additionally divided into strings with corresponding inverters.
5. Battery system – Suitable batteries are selected for the previously selected PV modules and inverters. Additional data can also be found here, such as the comparison between the connected load and the capacity of selected battery system, or its energy.
6. Cables – Provides the information about the connections of the entire system, along with possible cable losses.
7. Plans and parts list – Technical drawing of the designed system circuit with the specific numbers of individual components.
8. Financial analysis – What this category allows us to do is more precise allocation of costs. Individual parts of the system, processes and labour can be evaluated and given a specific cost amount.
9. Results – Overview of the results with diagrams for various parts of the analysis. Details of the configuration and the financial analysis are also included.
10. Presentation – Final output of the project is a document for the customer with entirety of the information from the previous categories. The document provides the customer with everything there is to know about the project.

6 Designing a photovoltaic system

First major step in the designing process is to determine the most optimal location for the photovoltaic modules to be located. As was mentioned before, there are several roof areas worth considering for this purpose. Alternatively, the modules could also be located on the ground as there is quite large in the northern part of the property that would, after some work, be suitable as a base for a photovoltaic system. However, given the extent of the work that would be needed, such as cutting down more trees and significant amount of fence work (as the area currently serves as a large poultry enclosure), the owners would only consider undergoing these procedures as the last option.

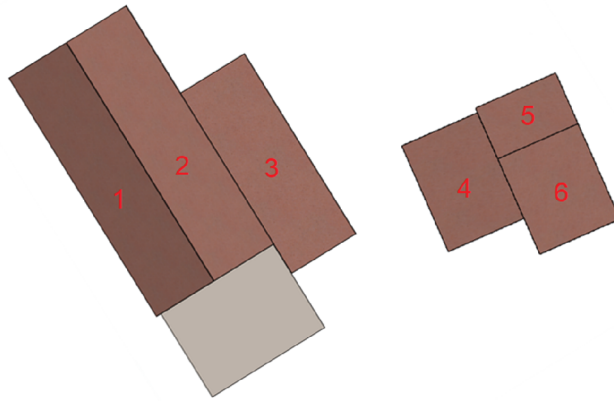

Fig. 6.1: Numbered representation of usable roof areas

Multiple conditions need to be met for a roof to be considered ideal for our system. First of those would be the total area of the roof, as the total number of installed photovoltaic modules might prove quite demanding in regards to space. As such, the more preferable options would be the roof areas marked as 1, 2 and even 3 (see figure 6.1), with the first two representing the largest available areas, each of 40,396 m². Subsequently, azimuth of each individual roof needs to be accounted for. Azimuth represents the angle at which the face of the installation is horizontally displaced from a set point, which in the case of photovoltaic systems would be the true South. That point (South) holds the azimuth of 0° and depending on the direction of the displacement, negative or positive angle is obtained, with west offset representing the positive values and east offset the negative values. With the azimuth set, the measured direction angles can be transformed into azimuth-angles. According to recent research [17], most ideal azimuth for a photovoltaic installation is between +2 and -4°. None of the available roofs, unfortunately, fall

under that category and as such we have to decide on the closest suitable candidates. With this in mind, roofs labelled as 1, 4 and especially 6 (see figure 6.1), would be our best suited choice, with the last one having an azimuth of -22° (South-South East). If we then compare this with the available area of each roof we can see the possible candidates more clearly (see table 6.1). Third very important information is the vertical angle of the roof as it directly determines the mounting angle of the photovoltaic modules and therefore influences the angle at which the solar radiation will be hitting the photovoltaic cells. If we combine all of the information, we can attempt to calculate probable monthly solar irradiance estimates for all of the roof areas to help us understand which ones would be the best suitable candidates for further simulations.

Tab. 6.1: Overview of available and simulated (July) roof data

Roof #	Area [m ²]	Azimuth [°]	Vert. Angle [°]	Estimated irradiance [KWh/ m ²]
1	40.396	61	41	155.92
2	40.396	-119	41	134.77
3	27.072	-119	0	165.86
4	15.246	68	18	165.8
5	8.750	158	27	139.86
6	15.750	-22	22	170.89

Although the above table determines areas 3 and 4 as the most optimal for our installation, other factors need to be taken into account, such as before mentioned shading. We can try and simulate this effect by using the built-in function of PVSOL. As there is nothing in the nearest proximity of the buildings with sufficient height profile (apart from the previously mentioned trees that are to be removed), the only significant instances of shading would be caused by the buildings themselves. Firstly, we can simulate shading on the two most promising roof areas:

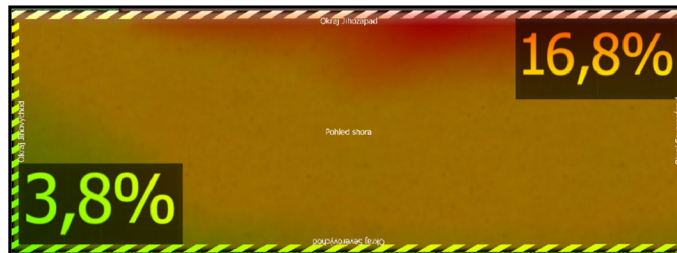

Fig. 6.2: Simulated shading on roof section 3

As can be seen from the figure above, the roof area is suffering from varying degrees of shading, in some places up to 16 %. To better illustrate the negative effects of this phenomenon, if we were to cover the entirety of this particular area with photovoltaic modules and compare between two scenarios, one with shading in mind and one completely without it. The area affected by shading would demonstrate a 22,8 % decrease in yearly energy yield compared to the instance of zero overall shading. Similarly, we can simulate shading on the roof section number 4 (see figure 6.1), and obtain the following results:



Fig. 6.3: Simulated shading on roof section 4

While not as high as the previous case, even this section is affected by shading caused by the surrounding heightened roof areas. In this example, the shading would lead to an 18 % loss of estimated yearly yields. While not as high as the previous example, in combination with the smaller available surface area and the potential losses being greater in percentage than the differences of estimated irradiance (see table 6.1), we should consider an area not as heavily affected by shading as these two. With this in mind, roof sections 1 and 6 should be the most suitable options as the only present shading is very minimal or none that would be caused by the closest surroundings. As can be seen on the following figure, the roof area number 1 only has a very minimal area shaded by the chimney on the opposite side of the roof ridge:



Fig. 6.4: Simulated shading on roof section 1

6.1 Safety of installation and operation

For a PV system to work properly, it is also crucial to implement certain safety elements to protect both the system and its surroundings from potentially very dangerous, unwanted circumstances. Some of the most important safety measures can be found inside ČSN 33 2000-7-712, Low-voltage electrical installations - Part 7-712: Single-purpose and special-purpose installations - Photovoltaic (PV) systems.

6.1.1 Disconnectors

In the case of maintenance or possible failure, it is vital to be able to disconnect the PV installation from the inverter and the rest of the system. For this purpose, switch disconnectors can be employed, allowing for a very simple method of disconnection. Requirements for a point of separation between PV installation and inverter are defined in ČSN 33 2000-7-712, but do not further specify the precise location of this separation point, allowing, in certain cases, for inverter-integrated disconnectors [18].

6.1.2 Surge protectors

Surge protection devices (SPD) serve as one of the methods (among others, such as common potential connection, shielding and grounding) for surge occurrence reduction. Installation of SPD on both DC and AC sides of the system, helps to prevent potential critical states caused by a lightning strike or a different source of surge. The DC side implementation is governed by IEC 60634-7-712 ed. 2, EN 50539-11 and technical specification CLC/TS 50539-12, while the AC side implementation is governed by ČSN EN 62305-4 [19].

6.1.3 Electricity meters

PV systems connected to the grid have to follow certain requirements for proper electricity meter setup. These requirements can be very strict and failure to meet them will, with high certainty, result in the distributor (as the requirements differ, based on the local distributor) refusing to connect the system to the grid. In the case of ČEZ, the extensive list of requirements is listed under their "Conditions for connection of electricity generation plants" (translated) [20] and include such requirements, as the mandatory inclusion of a mass remote disconnection module, to go along with the electricity meter.

7 Off-grid photovoltaic systems

7.1 PV system with full coverage of consumption

Our first goal will be to design a purely off-grid photovoltaic system. The main advantages of this solution are the independence on the grid which also corresponds with full self sufficiency. However, this method also entails a plethora of problems and obstacles which will be more expanded upon below. The main requirement is to create a setting in which the photovoltaic energy generation, in combination with an energy accumulation system, covers the entirety of the household consumption. As we have previously established that the average yearly consumption is 2258 kWh, the system is being designed around this number. It is important to take into account that while there is not a shortage of available roof surface only some of it is of more ideal conditions, which significantly shrinks the total amount of square meters available for the installation. Combined with the yearly consumption amount, the final design will require larger amount of installed power and batteries to achieve full self-sufficiency.

One of the key factors is the total size of available optimal roof area as it directly determines the amount of kWp that can be installed without the requirement for the highest available nominal power modules. In the first attempted simulation, the entirety of the roof areas number 1 and 6 (see figure 6.1) were covered with modules, to help establish a base for further testing. 375 Wp modules were selected for this purpose, as they fall on the higher end of the available range. To cover the entire areas, 24 total modules were used, bringing the combined power sum of these modules to 9 kWp. This is already quite high of a number, but not entirely unusual in modern installations.

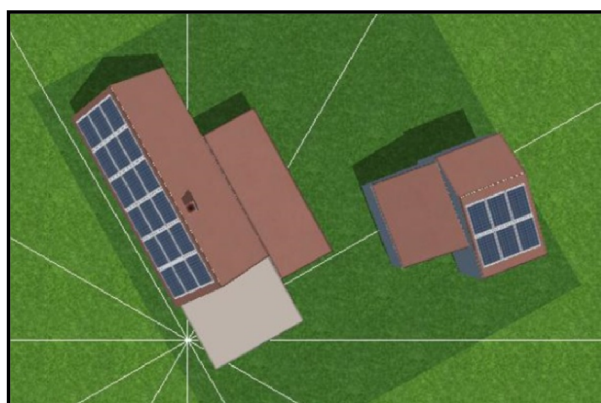

Fig. 7.1: View of the proposed module coverage on both roof areas

The problem, however, arises with the battery section. In order to completely cover the consumption, the battery system needs to be significantly up-scaled and with our currently mounted modules with standard inverter setup, the smallest amount of battery capacity, to fully cover the 2258 kWh of consumption, would be 176 kWh. As that is simply not feasible in the current state, different approach will have to be taken. Regardless of the following steps, the initial example simulation provided vital data, to better understand the issues at hand. Firstly, we can go over the generated data for energy production of the example system, specifics of which can be seen below:

Tab. 7.1: Specifications of the full coverage example PV system

Total consumption [kWh]	2 258
Total installed power [kWp]	9
Total battery power [kWh]	176

This first iteration of the system might seem unrealistically oversized, but it is one of the possible minimal combinations needed for the system to be able to fully cover the annual consumption. This is caused mainly by the insufficient photovoltaic generation during the lowest irradiance months of winter, in combination with power throttling at the inverter.

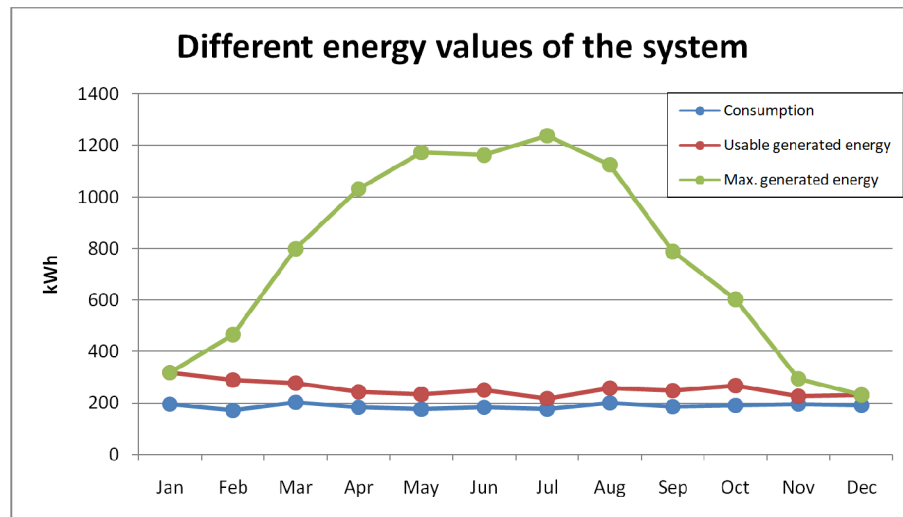

Fig. 7.2: Visualization of different energy values of the system

As can be seen from the previous figure (see figure 7.2), the oversized nature of the system leads to the generation of considerable quantity of surplus energy,

which cannot, at any given moment, be used to cover the consumption or charge the batteries, and is therefore throttled at the inverter. While on the other end of the spectrum, values for maximal possible generated energy in the months of January and December are equal to the values of usable energy. If the system was to be smaller in any of the installed parameters, the coverage of consumption would not be sufficient, and the system would no longer be capable of full off-grid operation without additional supplementation of energy.

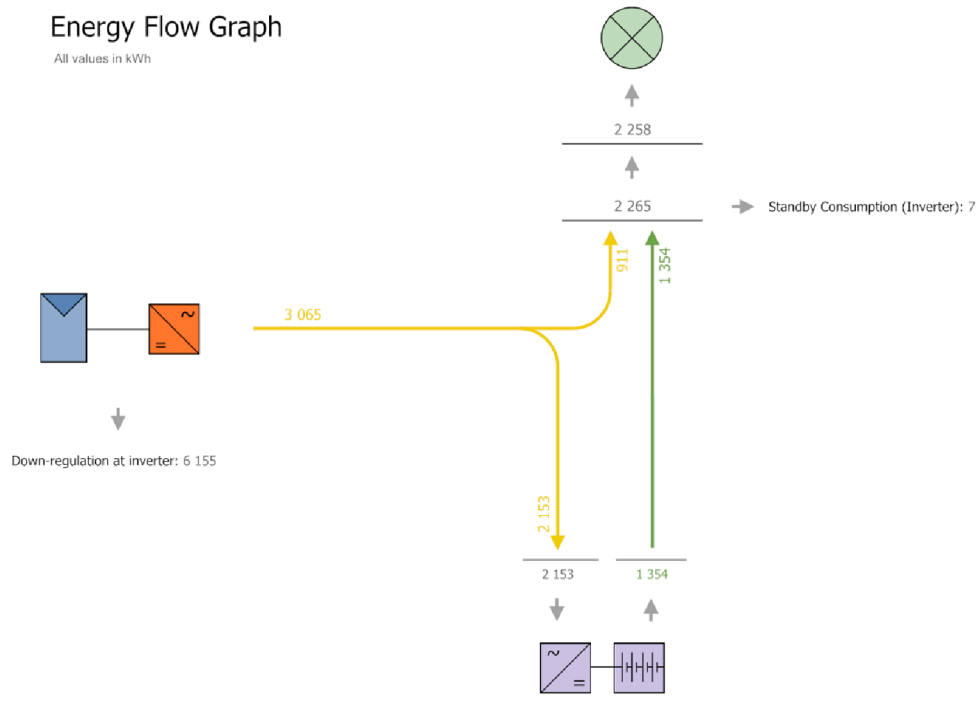

Fig. 7.3: Energy flow diagram for a fully self sufficient off-grid system

The above diagram represents the flow of energy in the system, so we can better understand the individual parts. Right at the first step, we can see that a total of 6155 kWh does not pass through the inverter into the system, due to the before mentioned throttling. As there is nowhere for the energy to go, when the current consumption and battery charging is already covered. Out of the total energy passing the inverter, almost a third is to directly cover the consumption, while the remaining amount is for charging the batteries. Due to losses during the charging/discharging process and additional battery system losses, only 1354 total kWh are then covering the rest of the consumption curve during for example the times of low available irradiance.

Additional problem that this degree of system over sizing presents (besides the very high cost of the installation itself) is that it might no longer be eligible for

certain subsidies, due to it no longer being regarded as a smaller household system. For example, under the guidelines of NGSP 2021, section C.3 defines the size of the installed system eligible for the subsidy to be of total power up to 10 kWp, while battery systems are to be sized between one and two times the total maximum power of modules in kWh [21].

7.2 Financial analysis of full consumption coverage

The biggest portions of the total cost of the system can be divided into several categories: Price of the photovoltaic modules, battery systems and inverters. As for the rest of the expenses, additional system components, cabling and work need to be taken into account. As we have already discussed (see chapter 5.1), the household is not eligible for the subsidy under NGSP 2021 [21] while the building is connected to the grid. Under the circumstances of it not being connected to the grid, the sizing requirement is still not being met, as the total battery capacity in kWh exceeds the total maximum power of installed modules in kWp.

One of the factors to consider, before assessing the cost of photovoltaic modules, is their maximum power. More modules with lower maximum power may cost less individually, but take up more much needed roof area and in higher number, their combined cost per kWp might even be higher. While not necessarily a universal rule applicable for every manufacturer, there is case to be made for higher maximum power modules as they may come with innate price reduction per kWp at higher maximum power (according to available market prices, 2022). With this in mind, our previously used panels could be replaced with higher maximum power alternatives to better utilize available space while also reducing the total kWh requirement of the battery system. Additionally, the following calculations only covers the cost of the components themselves, without accounting for the additional costs of the installation process itself, as well as previous statics check, possible logistics, and other expenses. New simulation was carried out, this time covering the entirety of the two previously used roof areas with different module types of higher maximum power: 450 Wp. Although higher Wp modules are available on the market, the size of the roof areas does not allow for more effective usage, as increase in maximum power is intertwined with increase in size of the module. As such, models with even higher energy density would be required. With the new type of module selected, the other components can be matched to create a basis for the new simulation. The following components were used:

From the table above alone, differences between the first proposed example system and the latest iteration are easily identifiable. Apart from the module change, batteries and their inverters were also replaced to match the rest of the system,

Tab. 7.2: Specifications of the simulated system

Total consumption [kWh]	2 258
Total installed power [kWp]	6.75
Number of modules [-]	15
Used module type	LONGI Solar LR4-72 HPH 450 M G2
Used inverter type	FRONIUS Symo 8.2-3M
Sizing factor of inverter [%]	115.2
Total battery power [kWh]	118
Used battery inverter type	Sunny Island 3.0 M
Quantity [-]	3
Used battery type	Victron Li-Ion 24 V 100 Ah 2.6 kWh
Quantity [-]	46

reducing their quantity in the process significantly. Still, however, the system is massively oversized for this type of household in order to just perform at the minimal level required to achieve self-sufficiency. We can better illustrate the scale by comparing the prices of individual components and arriving at the price total:

Tab. 7.3: Cost of the simulated system [36]

Components	Price + quantity [czk] [-]
Modules	5 400
Quantity	15
Inverter	54 909
Quantity	1
Battery inverters	61 894
Quantity	3
Batteries	31 200
Quantity	46
Total	1 633 003

We can immediately see the height to which the total cost is elevated. Complete off-grid self sufficiency comes with a very significant cost increase compared to grid-connected photovoltaic systems for an average household and is (in this case) neither economically nor environmentally viable. The largest portion of the component expenses are contained within the battery costs, as they present the backbone of the system with around two thirds of the consumption coverage, and a very important role during the low irradiance periods. It is also important to note that this only contains the key component costs and that all of the additional components and services would bloat the final sum even further. Unfortunately this course of implementation would not be viable and different approach is in order.

7.3 Alternative off-grid approaches

There are several options when the path of full self sufficiency based solely on large scale photovoltaic generation is not what the owners would prefer. First, the photovoltaic system would only serve the purpose of powering selected appliances, while the rest of the consumption curve would be grid-connected. It is important to determine the optimal degree of balance between self-sufficiency of the system and the final cost for its implementation. This approach can also only be implemented, if the building is connected to the grid and is not a truly off-grid household. Different option would be to enable load shedding. Load shedding presents the option to switch certain loads off during specified periods of the day. Lastly, a type of photovoltaic system supplemented by a backup generator can also be considered, where the generator circuit would run in place/alongside of the photovoltaic system when its production would be less than ideal, in order to cover the consumption.

7.3.1 PV system with load shedding

Load shedding represents the process of systematically disconnecting certain appliances during the times of low photovoltaic generation, in order to ensure that certain selected appliances with high priority remain functional. The process can be generally controlled by two factors: Time of the day and battery state of charge (SOC). Loads are switched on or off when the batteries reach certain top and bottom SOC thresholds. This process can then be divided into several time frames with different SOC control settings. Similarly, multiple layers of load shedding can be implemented, each one disconnecting a certain portion of appliances, depending on their assigned priority.

Implementation of this method would require dividing the consumption into individual appliances and sorting them into categories based on priority and usual time of activity per certain time frame. By following these steps, load shedding can be enabled, allowing for an off-grid system of much smaller size, with the stipulation of unavailability of previously defined appliance range appliances during certain time periods.

7.3.2 PV system for selected appliances

More of a straightforward method would be to only use the PV system to power certain loads only to which it would be connected. Certain appliances such as the refrigerator, etc. that require constant power and their function would be negatively affected during periods of downtime, should perhaps not be considered for the PV

circuit using this method. Yet again, a list of individual appliances and their consumption needs to be drawn up in order to come up with the most balanced solution of the system.

7.3.3 PV system with backup generator

Similar to how systems with enabled load shedding can switch loads on and off based on battery SOC during time of the day, backup generator operates on the same principle. When the batteries reach certain predetermined SOC bottom limit, generator takes over the supply and battery charging processes.

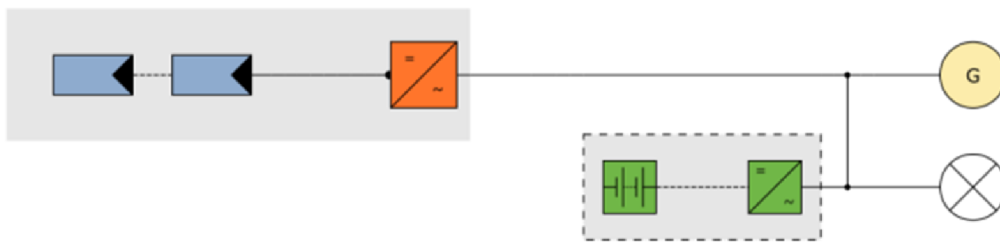

Fig. 7.4: Schema of an off-grid system with backup generator

Impact of the backup generator can be seen mainly in the problematic months of low irradiance, where most of its operation time is. It allows the system to function without the need for a large number of additional battery units, meaning it is also reducing the cost by a significant amount. Considering the previous system setup, with the help of a backup generator, we were able to reduce the amount of needed batteries down to around 15 kWh. It is however not just cuts in expenses, as the generator and fuel do come with their own cost, paired with the negative environmental effects, as it would with utmost certainty have to be a diesel fuelled generator. It however makes the process of running a fully off-grid photovoltaic system that much easier and cheaper. The resulting system and its energy flow diagram can be observed below:

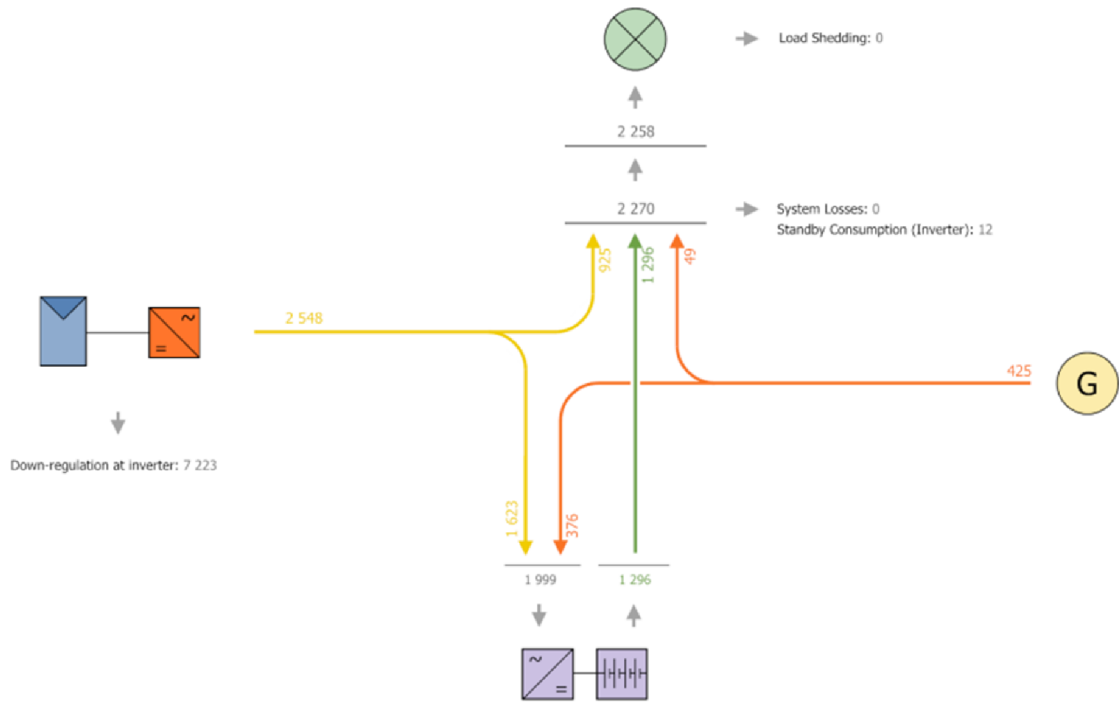

Fig. 7.5: Energy flow diagram of the backup generator system

The previously used system was edited by reducing the total battery power down to 15 kWh and pairing it with an 8.83kW three phase generator, regulated by battery SOC. The generator would allow for full function of the system with that much reduced battery capacity. Course of the generator's function during the year can be observed on the following diagram (see figure 7.6).

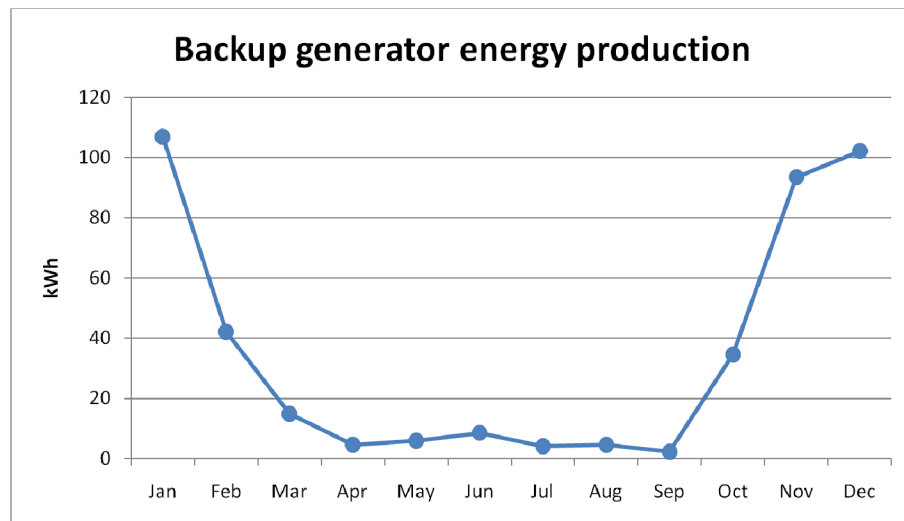

Fig. 7.6: Diagram of backup generator usage through the year

The diagram distinctly depicts the main time frames of concentrated generator operation. The total produced energy in this iteration is equal to 425 kWh, almost three thirds of which were during the months of November, December and January. By also reducing the required amount of total battery power from 118 to 15 kWh, it reduced the expected cost of the first system iteration by around 1 255 000 CZK, making this alternative seemingly more than promising option.

Naturally, this variant of system requires us to account for the cost of the generator itself along with additional costs of fuel, mainly during winter. As already mentioned before, the simulated example utilized 8,83kW, three phase generator, which would be an ideal example for this variant as is. Unfortunately, a generators with similar parameters are not as easily available on the market. This means an actual system would very likely utilize a smaller backup generator, which would mean an increase in its usage during the year in order for it to cover the consumption curve. The next step would then be to find the optimal balance between battery capacity and backup generator size (while also disregarding the pollution factor for now). The more easily available options on local market consist of smaller generators with lover power, generally around the point of 5-6 kW. For the next set of examples and simulations, a 5.5 kW three phase generator was used, with the following specifications:

Tab. 7.4: Specifications of the used generator

Nominal AC voltage [V]	230
Nominal AC Current [A]	8.3
AC Power [kW]	5.5
AC Power Rating [kVA]	6.25
N. of phases [-]	3

Using this example, we can plot several scenarios with increasing battery power in order to observe differences in the generator energy production during different periods of the year.

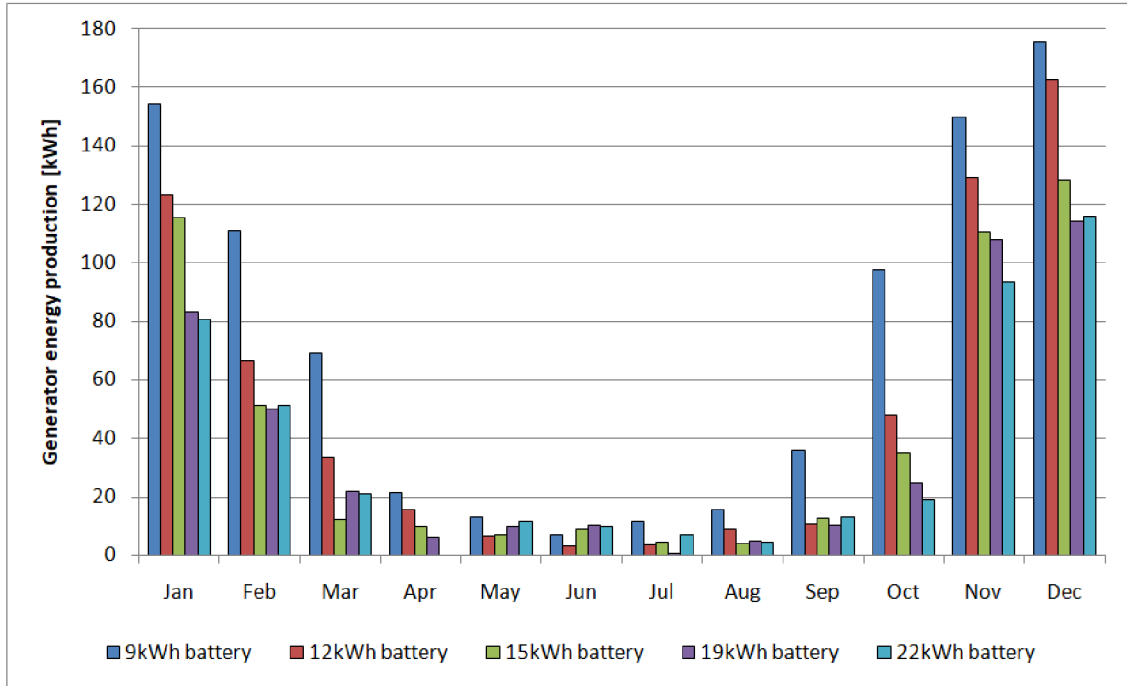

Fig. 7.7: Diagram of backup generator with different batteries

From the figure above, we can read information about different types of battery units and their corresponding data for generator usage. We used a range of possible batteries, starting at 9 kWh, with roughly 3 kWh steps up to 22 kWh. All of these battery options were combined with the exact same type of generator mentioned before (5,5 kW, three phase). Biggest difference in generator usage can be observed right between the first two options (9 kWh and 12 kWh), where the total annual usage drops from 861,4 kWh to 610,3 kWh, making it a difference of 251,1 kWh. What can also be observed is that the previously simulated trend of usage holds with the new battery combinations and the biggest portion of the usage consists of the months of January and December. On the contrary, some irregularities can be observed during the summer months, where despite growing battery capacity, the usage values do not always follow the expected trend. The most likely cause of this phenomenon are the higher levels of solar irradiance during those months which noticeably shift the the level of component importance within the system. Whereas during low irradiance periods, batteries play the more crucial part over photovoltaic modules, during summer and other high irradiance periods, modules are more capable of generating sufficient amount of required energy, therefore shifting the system priority, and making larger battery capacity less important. Combined with the inner simulation priority that is given to individual processes, this can lead to months, where despite higher capacity of battery system, the given variant displays larger generator usage. All of the values along with total values of usage and differences

between previous and current setting can be found in the following table:

Tab. 7.5: Generator usage data for different battery unit variants

	total battery power				
	9kWh	12kWh	15kWh	19kWh	22kWh
Month	Backup generator usage [kWh]				
Jan	154.5	123.1	115.2	83.1	80.6
Feb	110.7	66.5	51	50.1	51.2
Mar	68.8	33.2	12.4	22	20.8
Apr	21.3	15.5	9.6	6.2	0
May	13.3	6.3	6.8	9.9	11.3
Jun	7	3.3	8.8	10.3	9.8
Jul	11.6	3.5	4.6	0.7	6.7
Aug	15.7	9.1	3.8	4.7	4,4
Sep	35.7	10.5	12.8	10.4	13
Oct	97.5	47.8	35	24.9	18.7
Nov	149.9	129,1	110.3	108.1	93.6
Dec	175.4	162.4	128.3	114.1	115.9
Total	861.4	610.3	498.6	444.5	426
Difference		251.1	111.7	54.1	18.5

With all of the numbers together, more distinctive differences can be observed between the variants. Firstly, the biggest difference in generator usage can be observed between 9 kWh and 12 kWh brackets. Simulations concluded this difference to be 251,1 kWh which can then be relatively well translated into how much fuel would have been used, together with its price. Determining the fuel price is crucial for this step, however, given the current geopolitical factors of first half of the year 2022, it can prove difficult to determine it. The previously selected generator is a gasoline powered one, which means determining the current price trend of gasoline is in order. Czech Statistical Office can (for this purpose) provide a database of average prices of different fuel types going back as far as the beginning of 2016. Below are the average prices (in Czech Republic) of the most common fuel types for this particular purpose.

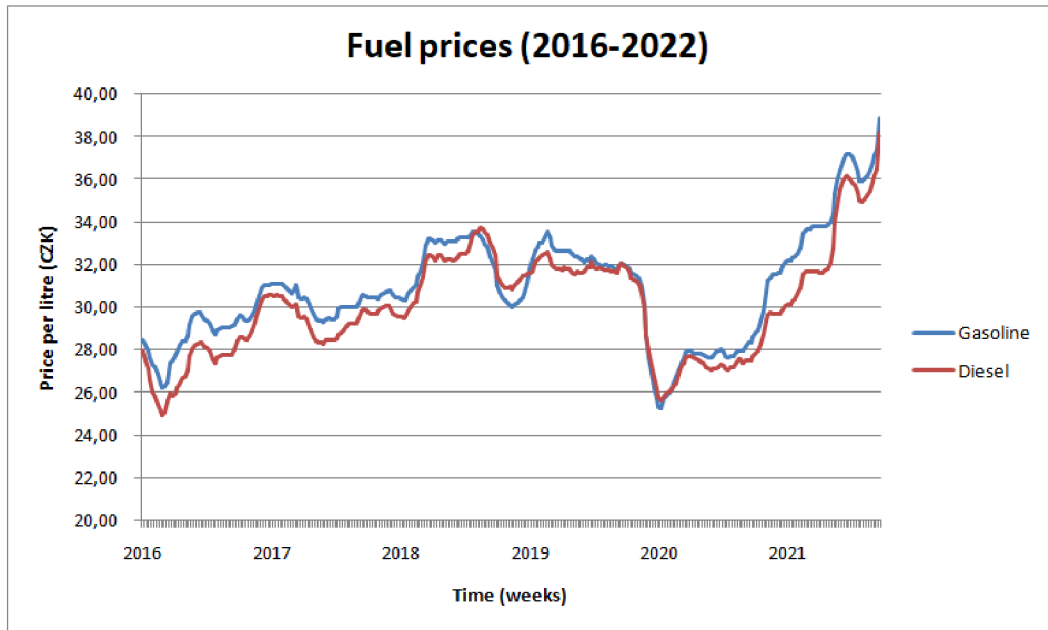

Fig. 7.8: Average price survey of selected fuel products (2016-2022) [22]

Observing the price trend from the above figure, lowest that the price of gasoline was during the last few years, was during twentieth week of 2020, when the average price per litre was around 25,24 CZK. Since then, the prices have been on a steady rise and recent events would only suggest this trend to persist in the nearest future. At the moment (ninth week of 2022), average price per litre of gasoline hovers around 39 CZK, with suppliers already moving above the price point of 40 CZK per litre. This can have significant impact on the financial viability of the entire photovoltaic system, depending on the amount of energy supplied by the backup generator, and it is therefore even more crucial to find the correct balance of battery storage and generator usage.

Given the fuel price analysis, for the purpose of the following calculations, the most recent data point will be used as the price per litre variable. In this case that means a sum of 38,86 CZK per litre of gasoline, which in turn leaves us with the following simulated data:

Tab. 7.6: Yearly generator consumption and costs of fuel

Battery power [kWh]	Total generator usage [kWh]	Fuel consumption [l]	Fuel cost [CZK/year]
9	861.4	397.8	15 457.34
12	610.3	294.8	11 455.44
15	498.6	247.6	9 620.18
19	444.5	223.2	8 674.33
22	426	215.4	8 370.06

The simulated values for generator usage from previous step follow exponentially decreasing trend, which in turn translates into fuel consumption of the same trend. If we then use the average cost of fuel per litre, we arrive at the operation costs of a backup generator per year. The exponential decrease in costs with higher battery unit power can be better observed in the following diagram:

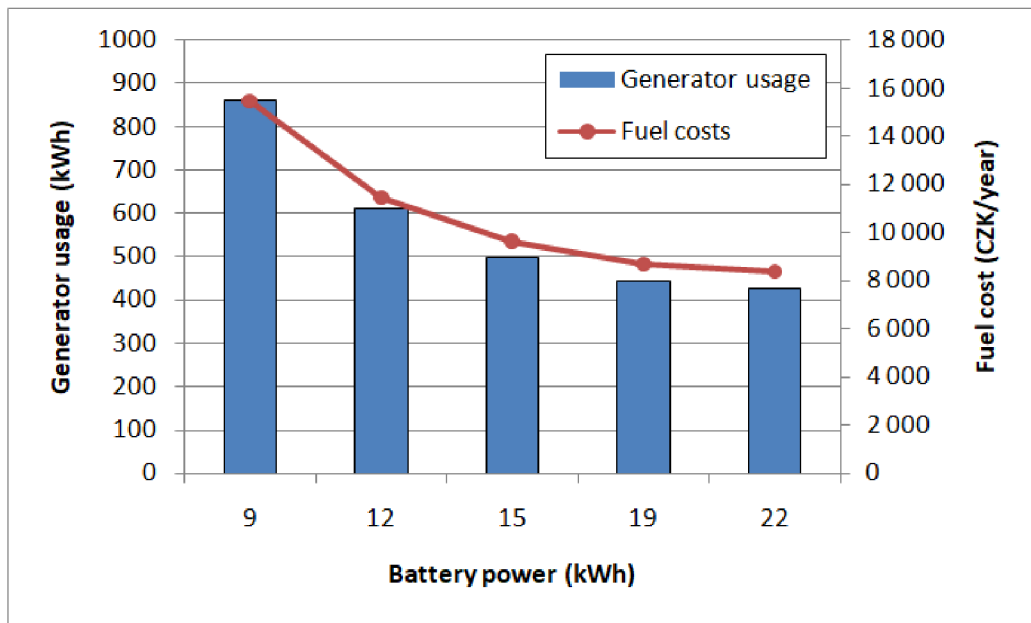

Fig. 7.9: Generator usage and fuel costs per year

With this in mind, we can make a more educated attempt at identifying the point of optimal battery power and generator usage ratio. The biggest decrease between two variants (in usage and therefore also in price of fuel) is between the 9 kWh and 12 kWh battery options with a difference of around 4 000 CZK per year. This sum needs to be compared with price increase per each battery kWh while also taking into account the average battery life expectancy, which (according to recent

research) should be within the bounds of 8 - 12 years if managed under real working conditions [23]. Therefore, given the most optimal conditions and a 12 year battery lifespan, difference between the 9 kWh and 12 kWh in fuel price would be around 48 000 CZK. This alone might seem as a reasonable incentive to lower the overall usage of the backup generator in favour of more total battery capacity, however as we have already touched upon the subject of battery lifespan, we can also conclude the cost of battery unit replacement at the end of its lifespan. We can partially simplify the computations by obtaining a set price per each installed kWh of the battery system, while using the already expanded upon system from previous system variants (See section 7.2). From those numbers, we arrive at an estimated price of 28 785 CZK. This makes a difference of 86 356,41 CZK, which would represent the additional expenses between 9 and 12 kWh system options the life cycle of an average battery system, deeming the previously mentioned 48 000 CZK of savings less significant. It therefore turns out (given the backup generator option) that the price of additional battery kWh outweighs the possible savings they provide on the backup generator yearly usage, and it would therefore be more economically viable to minimize the total battery power at the cost of increased generator up-time. This is of course without taking into account the environmental ramifications of such approach.

8 Hybrid photovoltaic systems

When none of the off-grid options provide the desired results, the best solution would then be a hybrid photovoltaic system. This option combines the self-sufficient aspect of the off-grid method, with the reliability of a grid supplier. Main difference between hybrid and off-grid systems is that the latter option is in itself connected to the distribution grid and can, if needed (during the times of low photovoltaic production), draw energy directly from it, all the while also being connected to a battery system. This option would help solve the issue of the problematic generation period during winter months, while also making the project eligible for additional subsidies, such as the NGSP 2021 as was discussed before (See section 5.2).

8.1 Hybrid system subsidies

The primary possible cost reduction for our selected system, or rather for its initial cost, would be taking advantage of the NGSP 2021, more specifically its subsection C.3 about photovoltaic systems. This program is run by the State Environmental Fund of the Czech Republic with the goal of financing projects they deem worthy in the area of improving the quality of environment and protection of nature.

This section also specifies the amount of funds that the applicant should be eligible for if certain conditions (above the mandatory conditions for the program subsidy itself) are met. The individual parts of the subsidy are defined in the following table:

Tab. 8.1: NGSP subsidy amount of subsection C.3 [21] - translated

Installed parts of a PV system	Subsidy amount [CZK]
Minimal installation of 2 kWp power	40 000
Minimal installation of 2 kWp power with hybrid inverter	60 000
Minimal installation of 2 kWp power with effective use of a heat pump	100 000
Per 1 kWp of additional installed power above 2 kWp	10 000
Per 1 kWh of electrical accumulation system (lithium-based)	10 000

In addition to these, there are also special circumstantial additions to the total amount. One of those concerning the location of the installation. If the system is to be located in one of the selected regions, including the Moravian-Silesian Region, then the total amount received can increase by additional 10% up to a total of 60%, while the flat total amount can go from 200 000 CZK to 220 000 CZK. Furthermore a 5 000 CZK bonus can be applied, if a licensed expert is employed to prepare a

professional opinion for the application, to provide an expert technical supervision and to measure the air permeability of the building envelope [21]. This would bring the total attainable amount to 225 000 CZK or 60% of the total initial cost.

8.1.1 Requirements for NGSP 2021 subsidy eligibility

Conditions to qualify for this particular subsidy are comprised of several different requirements listed under the subsection C.3 of NGSP 2021 guidelines [21] The first major one being that the system, or rather household requesting the subsidy, is also connected to the grid if it is not a matter of an off-grid system, and the electrical energy is being produced for the household in which the system is installed (barring specific exceptions).

Furthermore, condition a) of subsection C.3 defines the maximum installed power in PV modules to that of 10 kWp. Any installations above the limit are no longer eligible for the subsidy. Additionally, if the installation contains a battery system, then (according to condition h)) the size of that system must fall between 100 % and 200 % of installed PV module power, with the supplemental rule that excludes lead based battery systems. This presents one of the more important limitations to the system planning. If we take a look at the previous off-grid example (See section 7.2), which was largely up-scaled in order to completely cover the consumption, it is apparent that it would not fit within these new parameters as the total kWh of that system greatly exceeded 200 % of the installed 9,45 kWp of PV modules. As a result of this, the proposed hybrid systems will largely be dependent on these two limitations, leading to a smaller scale PV systems in order to qualify for the subsidy.

Condition b) states that the system is only eligible for funds if it is a new installation, as the subsidy does not apply to expansion nor additions to already existing systems. Similarly, it cannot be used for purchase of additional batteries to existing systems. Also, given condition i), the system needs to be placed directly on the main household building, different building with additional function to the household or a specially designated construction that will in no way restrict possible vegetation growth. Both of these conditions do not represent a problem for this project as it is a new considered installation with enough designated roof space on both the main and other buildings. If we were, however, to utilize the area of open land to mount the panels (instead of the roof), it could present problems related to the vegetation growth aspect.

Several following segments of the instructions specify the conditions under which inverters have to be connected and operating in the system. Firstly, connected inverters have to fulfill minimal efficiency of at least 95 %, or 92 % for hybrid inverters (See section 8.2). Furthermore, inverters that are connected directly to

PV modules have to be fitted with a maximum power point tracker technology (See section 4.2) that is of at least 98 % efficiency. To follow this regulation, technical documentation of considered inverters needs to be checked in order to determine the efficiencies (along with other technical parameters we would normally look for). If separate inverters are to be used to connect battery system and to connect the PV modules, both of those need to satisfy the efficiency requirements. Next, all connected inverters have to comply with Commission Regulation (EU) 2016/631 which determines a set of requirements for grid connection of generator entities. Further they also need to be in compliance with EN 50549-1:2019, a norm, which sets requirements for generating plants that are connected in parallel with the grid.

Given condition f), used PV modules also have to be of certain minimal efficiency. This value differs for individual types of modules. Our main concern are the mono-crystalline and alternatively poly-crystalline modules. In both of these cases, the required minimum efficiency is set to 18 %. Again, technical documentation for our considered PV modules needs to be reviewed for the efficiency values. If we take a look at our table of available PV module range (See table 3.1), we can observe their efficiency values, taken from respective manufacturer documentation. Given those examples, we see all of the mono-crystalline modules are within the required efficiency limits. and therefore further confirm the mono-crystalline technology as our primary candidate for PV modules.

Remaining set of conditions regulates the usage of a heat pump in the system. This represents an alternative method of energy storage, compared to battery system and as such the option does not represent a primary discussion topic of this thesis. Nonetheless, the requirements for the heat pump under condition set j) dictate its use as a main source of space and water heating. Additionally, the accumulation tank used in the system is required to have a volume of at least 400 liters. Further, similarly to the function of MPPT on PV modules, the regulation system of the heat pump needs to monitor and adjust its power in order to maximize the energy production. The final remark limits the provision of this subsidy as it is can not be combined with other subsidies of NGSP 2021, namely the subsection C.1 concerning heat source exchange.

8.2 Hybrid inverters

As per the definition of NGSP 2021, in order for a system to be eligible for its subsidy, it is also required to operate using a hybrid inverter if connected to the grid. Such type of inverter is distinguishable by how it operates. Furthermore, the NGSP 2021 guidelines give us a clear definition of what is considered a hybrid inverter, which reads as follows [21]: Inverter designed for photovoltaic systems,

equipped with both photovoltaic and battery inputs that is also capable of an off-grid operation. This means that the inverter operates as an inverter would in any grid connected PV system while also having the benefit of storing excess energy from PV modules into batteries. This energy is then utilized during low production periods or possible blackout situations. In addition, having a hybrid inverter in a PV system with batteries eliminates the need for an additional battery inverter, further simplifying the hardware requirements.

8.3 Hybrid system prototype

While designing a hybrid variant of a photovoltaic system, we can keep in mind that we are no longer required to fully cover the consumption of the household. The household itself is connected to the grid and therefore a much smaller photovoltaic system can cover the consumption during peak production times, whereas the grid (much like the backup generator variant) is able to supply the household during low production times. This means that both amount of total installed kWp in the form of modules, and total installed battery capacity can be (under the right conditions and in the correct combination) significantly lowered. Given this, we can also decide on which roof will be our primary mounting space as some iterations of the hybrid variant will be designed with fewer modules in mind and therefore will very likely be mounted on just one of the roof areas. As the previously selected and used roof areas present very comparable data for solar irradiance with minor differences in possible surface reflection, which help and balance the fact that the roof area marked as 6 (see figure 6.1) is more suitably oriented to the south, rather than the south-west orientation of the roof area number 1. Factor that will have more weight on this decision is how many modules are we able to mount on the individual areas, in which case, area 6 falls short, being able to hold around six modules, depending more specifically on their dimensions. For that reason, we shall consider the area number 1 as our primary mounting space.

With the primary area determined, several prototype simulations can be made to determine the most optimal number of mounted modules in order to optimize the ratio of generated energy and energy that is being supplied by the grid. As an example, the first iteration consists of the following specifications, with panels mounted on the roof area number 1:

Tab. 8.2: Specifications of the first hybrid iteration

Total installed power [kWp]	2.5
Number of modules [-]	6
Used module type	LONGI Solar LR4-72 HPH 450 M G2
Used inverter type	SolaX Power Co., Ltd. X1-2.5
Total battery power [kWh]	4.5
Used battery inverter type	SMA Sunny Island 4.4M
Used battery type	HOPPECKE powerpack premium 5.0/48

As we can see, we are still operating within the conditions of the NGSP 2021, specifically its condition h) (see subsection 8.1.1) where the size of the battery system is between 100 % and 200 % of the total installed PV module power. Similarly, the efficiency values of the inverter are also being fulfilled. It is important to keep these conditions in mind in order for the system to later qualify for the possible financial benefits. If we make a year long simulation of this system, we arrive at the resulting energy values:

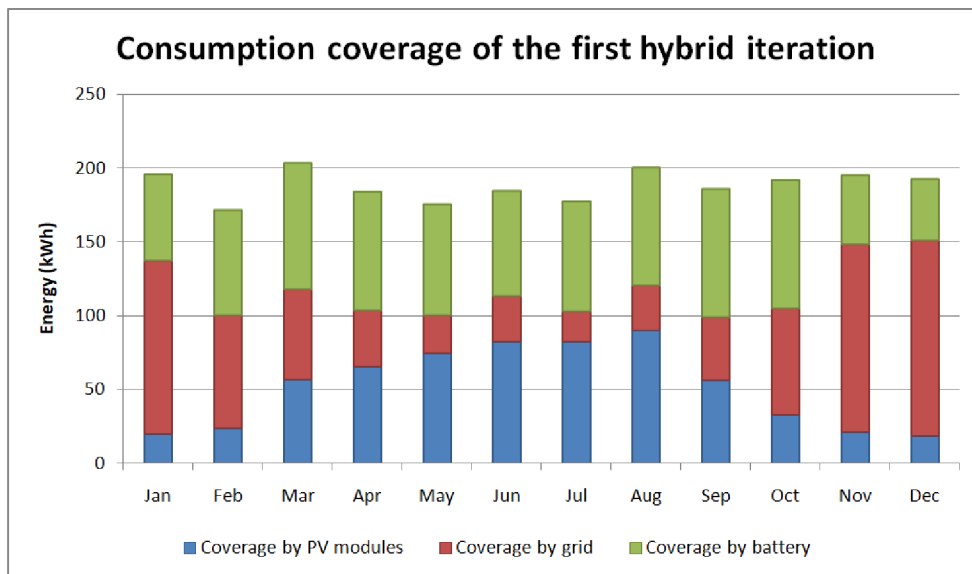

Fig. 8.1: Overview of consumption coverage for the first iteration

While the combined coverage via PV modules and batteries in this case is not insignificant, there is certainly space for more optimization. The total combined non-grid coverage of consumption is around 66 %, which leaves the remaining 34 % of consumption to the grid. The most significant grid-dependent months span from November to January, making up 48,5 % of the total grid coverage. The goal here would be to try and eliminate all of the grid coverage during the summer period,

while simultaneously not over-sizing the system above reasonable line. To better visualize the ratio of individual energy sources, the following pie chart is included:

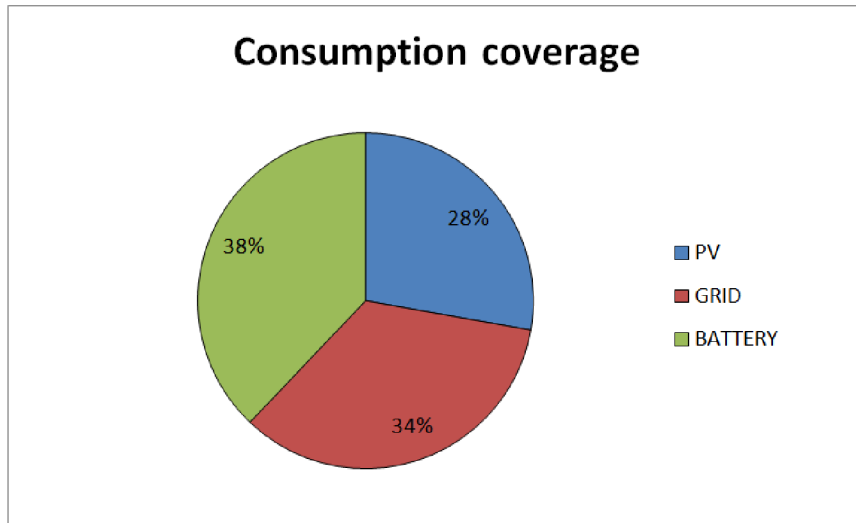

Fig. 8.2: Consumption coverage ratio of the first iteration

The next step would therefore be to make more simulations with different number of installed modules, alternatively adjusting the battery and inverter models, if necessary, to accommodate for the system and NGSP 2021 requirements (see subsection 8.1.1). In the next iteration, the number of 450 Wp PV modules was increased to 10, adjusting the type of inverter in the process.

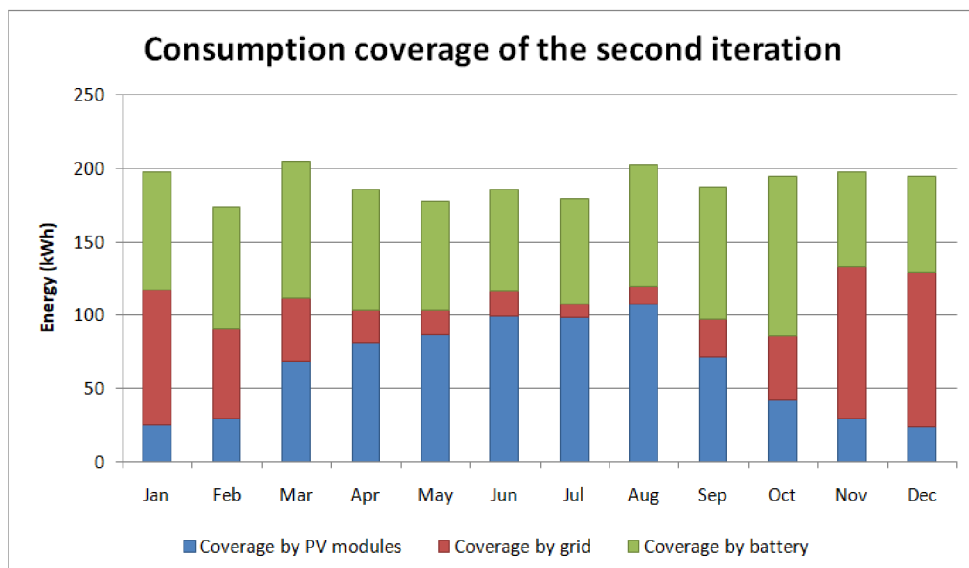

Fig. 8.3: Overview of consumption coverage for the second iteration

Visible differences in the coverage ratios should be observable, mainly the decrease of grid coverage percentage. It is also important to note that certain insignificant values were omitted from the figures, such as the standby inverter consumption during the year as they did not shift the overall percentage values and were visually almost indistinguishable if put into the graph. Again, to better help and illustrate the ratio changes, following pie chart is included:

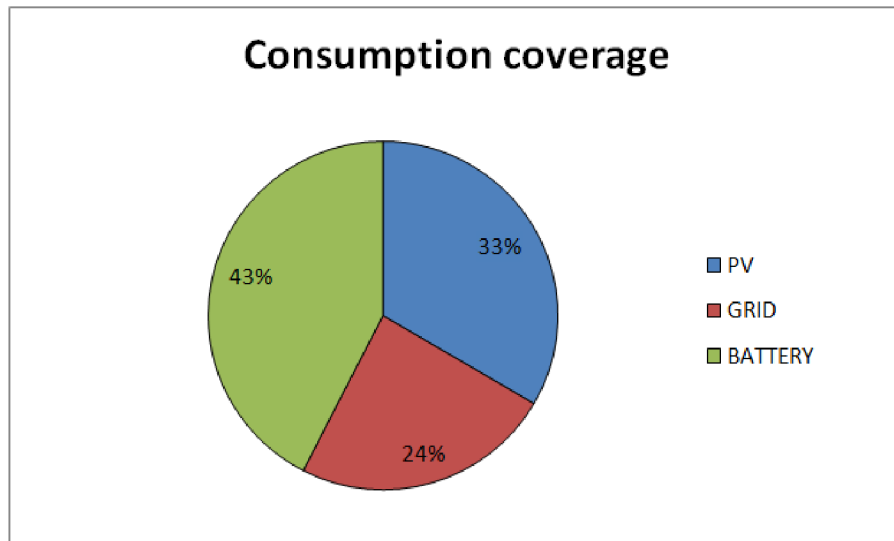

Fig. 8.4: Consumption coverage ratio of the second iteration

First and the most important change is the 10 % decrease in grid based coverage of consumption that the additional PV modules helped achieve. The installed PV output rose to 4,5 kWp, bringing it at the lower limit of 100 % of the prescribed PV - battery sizing requirements set up by NGSP 2021. The most important question, however, is yet to be answered by comparing the costs of the additional PV modules with the 10 % grid coverage reduction. The simplest possible way to just roughly determine the value would be comparing the module prices per kWp with the energy expenses per kWh, using the available data. From the documentation provided by the household owners and the archive of the distributor, the average price per kWh (assuming at the time available documentation, see chapter 5) was 6.455 CZK. With the 10 % consumption savings in mind, that brings the cursory value provided by the additional panels up to roughly 1 458 CZK in savings per year, assuming the previously set average consumption. Assuming an average of 6.455 CZK per kWh again, means that the total yearly energy expenses would amount to 14 575 CZK. If we deduct the 76 % covered by the PV system, we are left with 3 498 CZK. This amount represents the 24 % covered by the grid yearly, which means roughly

11 077 CZK in electricity savings each year. However, this is not quite accurate and representative of the actual state of the energy flow in the proposed system. The accurate representation of which can be observed below:

Energy Flow Graph

All values in kWh

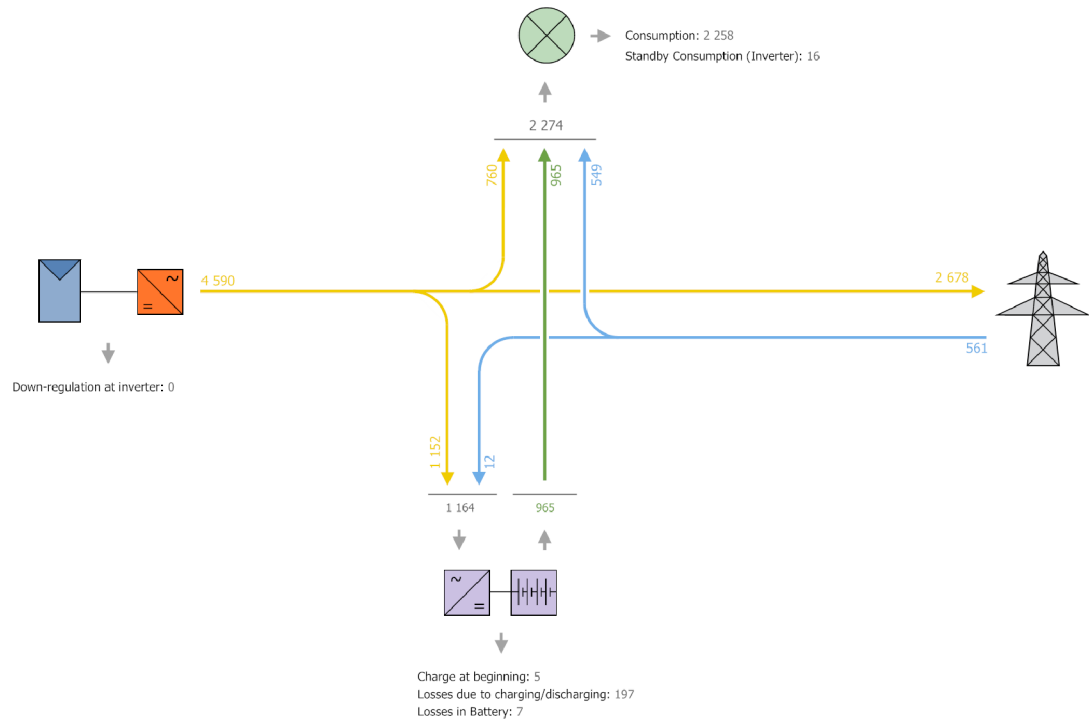

Fig. 8.5: Energy flow diagram of the second hybrid iteration

One of the main advantages of a hybrid system connected to the grid is the ability to feed the excess energy, that is not being used within the system, back to the grid. As can be seen from the above figure, this fed-in portion represents 58.34 % of the total annual generated energy, which means that the system is only utilizing around 42 % of what it generates each year. For better, practical representation of the energy flow we can observe the following chart, which represents selected energy flow elements displayed over the course of a week. The specific time frame for this representation was chosen to be a week in the month of July, as to better visualize the energy flow due to higher average irradiance values.

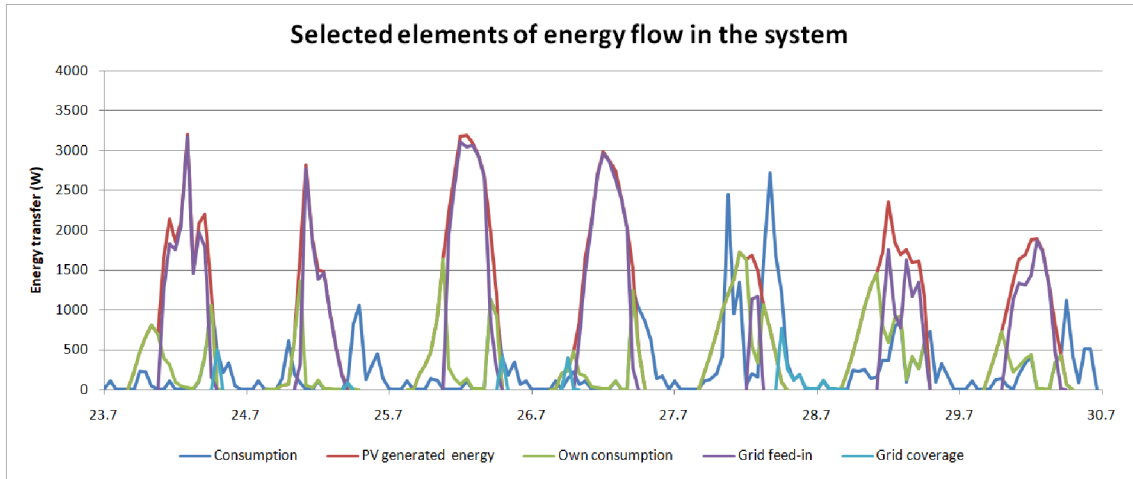

Fig. 8.6: Energy flow of selected elements (second hybrid iteration, July)

The differences should be apparent immediately. Individual days vastly differ not only in consumption values which fluctuate from relatively very low (23. 7.) to high values (27. 7.), but also in how the generated PV energy is utilized within the system. Some of the days, large portion of the generated energy has no use in the system itself and is directly fed into the grid, while other days the grid feed-in values represent but a small portion of the total energy flow.

Clearer observations about the distribution of the generated energy can be made from portions of the previous figure. During the main irradiance periods of each day, generated PV energy is split according to the needs of appliances and batteries. Energy that can power neither of the requirements, can then be fed to the grid. Additionally during the times of low or no solar irradiance, grid can supply the household. We can use several of the individual daily charts from the previous figure as a more clear representation to evaluate the data while simultaneously demonstrating several phenomena which take place in the system during its operation. Additional elements were added into the charts for more accurate depiction of the complete energy flow.

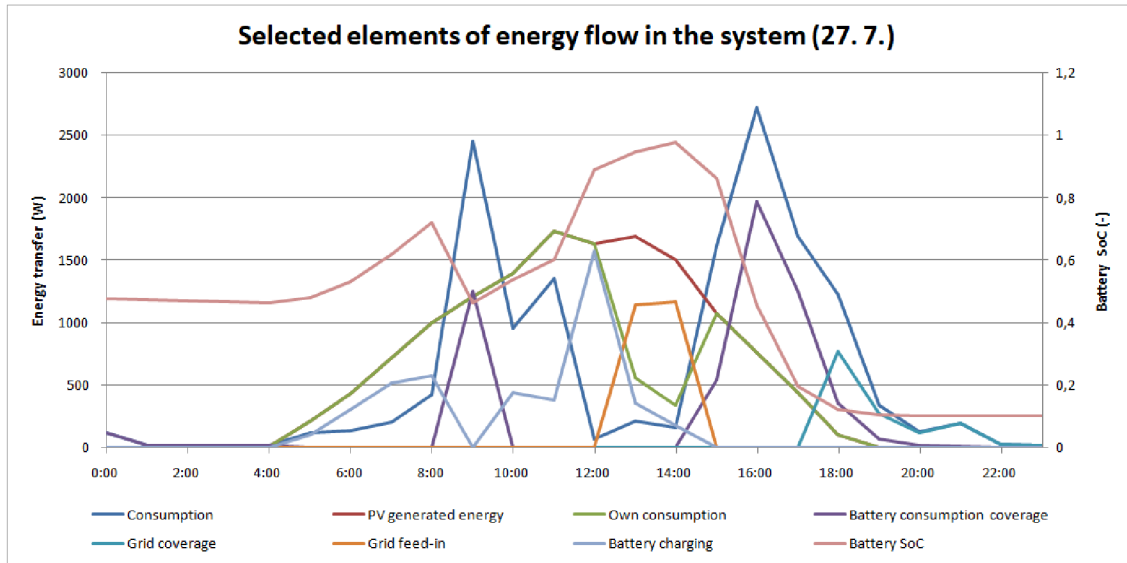

Fig. 8.7: Energy flow of selected elements (27. 7., second hybrid iteration)

Although it might seem that the previous graph contains excessive amount of characteristics, they are all relevantly interconnected. We can start with the most important attribute: consumption. This curve represents the energy requirements of the household appliances that need to be covered by one of the available means. One of those means can be the energy generated by the PV modules, which we can see being generated from 4:00 to roughly 18:00. This energy is then used to supply the appliances, charge batteries or alternatively, when the consumption demand drops low enough (such as between 12:00 and 14:00), to feed energy back to the grid. When the consumption demand is above the available PV production, batteries begin to supply the appliances as well. We can observe this phenomenon around 9:00 and again between 14:00 and 20:00. When the batteries state of charge gets progressively lower during this process, it eventually reaches a bottom limit beyond which the batteries will no longer cover the consumption. And if the PV modules are also unable to cover during this time, the grid will begin to supply the system instead. This can be observed around 17:00.

The second example shows data from one day before, with substantially different distribution of values through the day:

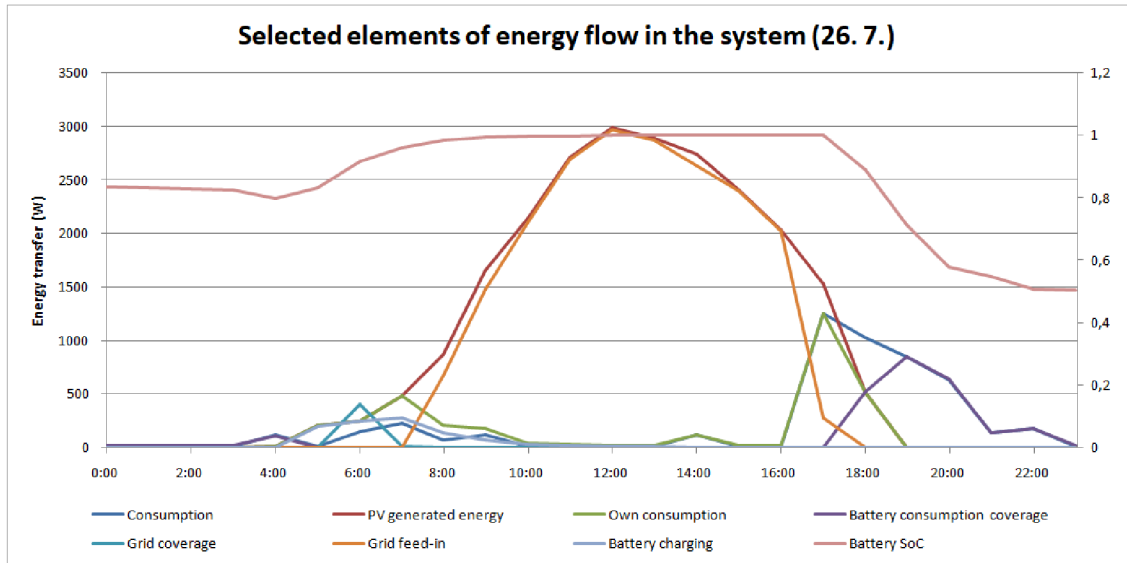

Fig. 8.8: Energy flow of selected elements (26. 7., second hybrid iteration)

As we are already familiar with the individual elements from the previous example, it should be noticeable that the consumption demand of this day is much lower, only reaching very low values in the morning and slightly higher values in the evening. This primarily means that generated PV energy can be used in different ways, rather than primarily covering consumption. The immediate second option would be charging the batteries, which actually happens between 4:00 and 10:00. However, the SoC quickly reaches its upper limit, meaning the batteries are now at full capacity and can not be further charged. In which case the system moves to the third option, which is grid feed-in. This is how the generated energy is used during most of this day, until consumption rises at 16:00, which changes the priority of the system and the generated energy is now being used to power appliances again. However beyond roughly 18:00 the demand can no longer be satisfied by the decreasing PV production and instead, batteries start taking over, which can also be observed via the changing SoC. Along with better illustration of the daily energy system flow, these characteristics also help and explain the previously discussed higher number of energy that is not utilized by the system and instead fed to the grid.

One of the conclusions that can be made after these observations is that during plenty of days, the generated energy has no other use in the system, than to be fed into the grid. The causes of this phenomenon can be narrowed down to two main problems. Consumption during the highest energy production periods is rather low, meaning these two areas do not particularly intersect; and battery charge during these periods is also (on average) at a higher (if not at maximum possible) value.

To contrast this with the periods of much lower solar irradiation, we can plot sim-

ilar graphs from simulated days near the end or start of the year in order to observe the energy flow element layout under different external circumstances. Whereas during July, the energy generated by the PV system was more than enough to cover the consumption (see figure 8.6), we are seeing considerably different results during December.

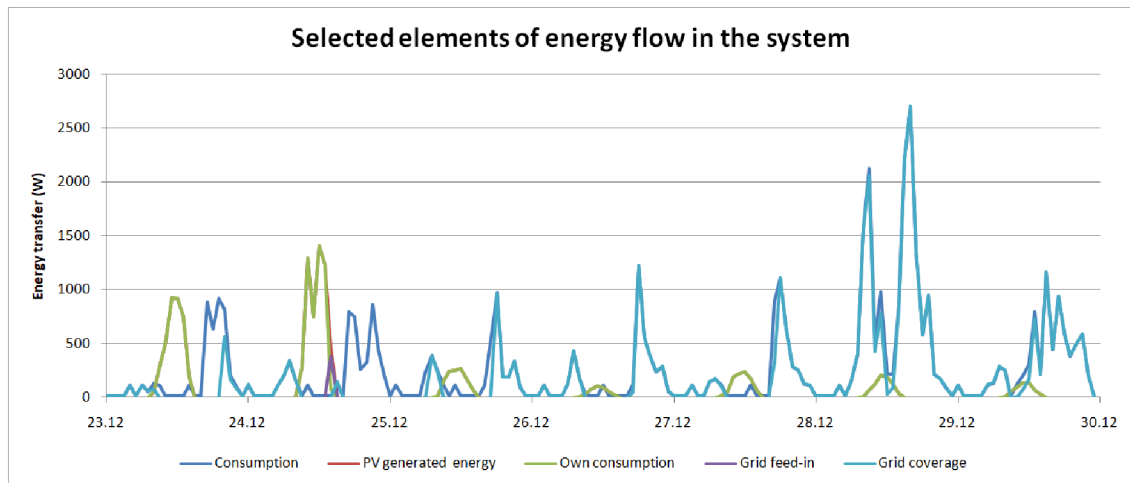

Fig. 8.9: Energy flow of selected elements (second hybrid iteration, December)

As expected, the generated energy values are scarcely sufficient for any decent consumption coverage and vast majority of it is being covered by the grid. Similarly, energy being fed to the grid is also at minimal values, as the total combined amount for the entire month of December is only 17,5 kWh, whereas the amount of energy being supplied by the grid during December is 105,2 kWh.

Closer look at individual days and more complete energy flow can again provide more insight into the phenomenon. Days with very minimal PV generation, like the one depicted by the following figure, are very common during this time of the year.

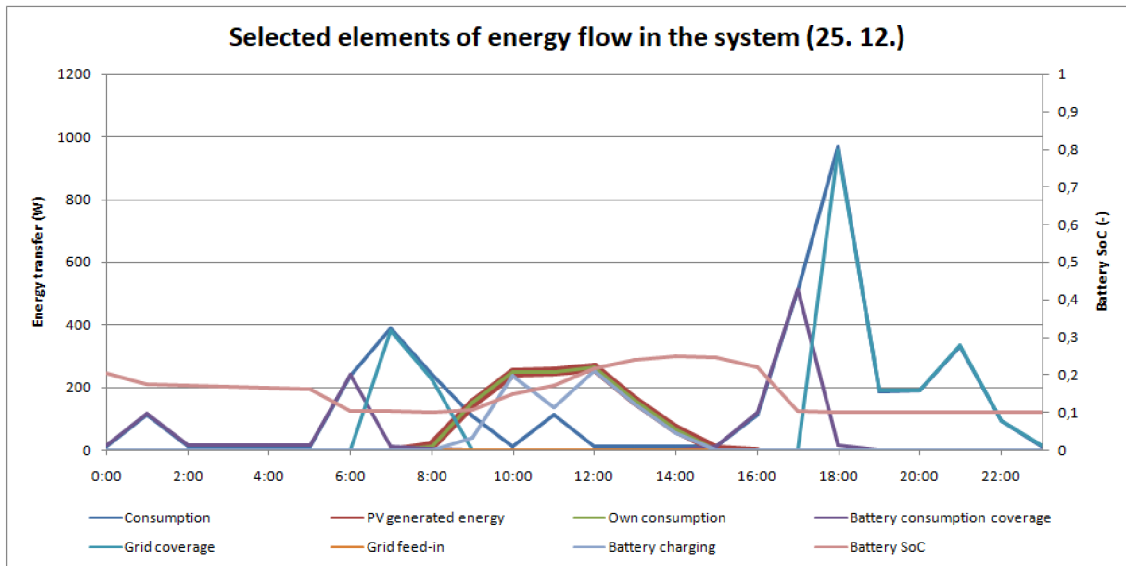

Fig. 8.10: Energy flow of selected elements (25. 12., second hybrid iteration)

Taking a closer look at the graph itself, we can immediately see the very low value of battery SoC. This is a very common occurrence during this period, as the modules rarely generate enough energy to cover consumption, let alone have surplus to charge batteries. We can also notice the absence of any grid feed-in, as the only produced energy (from 8:00 to 16:00) is immediately used for own consumption. Other than that, the rest of the energy demand is covered by a small amount of battery charge, before switching to full grid coverage mode, as the battery SoC is at the minimal value (around 17:00).

8.4 Improving daytime efficiency of the PV system

Previously, we determined that although the consumption coverage from the grid was reduced to 24 % (see figure 8.4), we are still achieving relatively low amount of own consumption within the system. The main issue lies in the fact that the areas of high production do not always intersect with the areas of high consumption. This leads to large amounts of produced electricity having nowhere else in the system to go, once the available consumption and battery charging are satisfied. Seemingly the only available option is then feeding the electricity to the grid. The viability of this option of course depends on the available feed-in tariffs, the distributor is able to provide and this topic will be covered in more detail later in the thesis. There is however a second option, albeit arguably harder to implement, which is load shifting. It represents the act of moving your consumption during the day to better intersect with the production periods and maximize own consumption of the

household. In practice, however, it would require postponing or maximizing the usage of appliances during the high irradiance periods of the day and reducing their usage to a minimum when PV energy is not being generated. This would also be complicated by the sheer variability between individual days as the PV generation is not particularly stable. Under ideal conditions, the results of load shifting could be similar to the figure below:

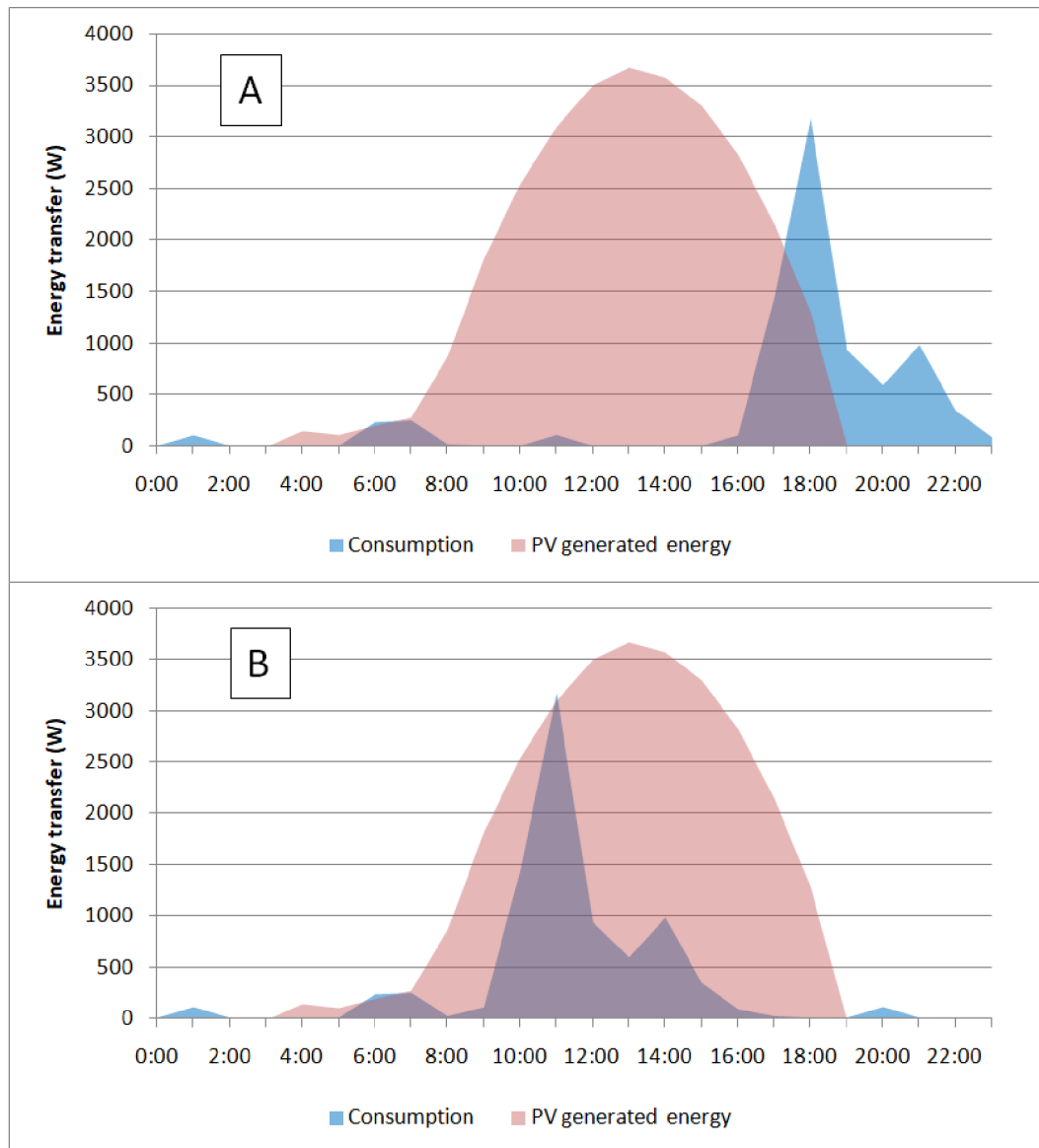

Fig. 8.11: Consumption diagram example (A) with ideal application of load shifting (B)

Actual implementation of load shifting could prove difficult, as the options for own consumption maximisation during the daily peak periods are, in this case, limited. Neither air conditioning nor heating will be mediated through the PV

generation. Apart from this, the remaining possibilities to manipulate consumption distribution would be mainly chargeable devices and since those do not make up a significant percentage of the consumption, the results would not be proportionate to possible taken measures.

8.5 Feeding electricity back to the grid

Since load shifting is not (in our case) as viable as could be hoped, grid feed-in is the most advantageous remaining option when dealing with surplus energy. This allows the owner to monetize their electricity surplus via a contract with the distributor. The purchase price is set by and naturally varies between the distributors. For our selected property, ČEZ is the distributor and therefore they set the feed-in prices. The company provides potential applicants with the following formula for feed-in price calculation [24]:

$$Feedin_{CZK/MWh} = cOTE_{DT} * CNBrate_{CZK/EUR} - 400 \quad (8.1)$$

The formula consists of two main variables. The first one being the OTE_{DT} , which represents the daily market price of electricity as given by OTE (Czech electricity and gas market operator) [25]. We can set the beginning of 2017 to be our starting point, given that the earliest available distributor electricity prices begin with this year. Visualizing these values, leaves us with the following characteristic:

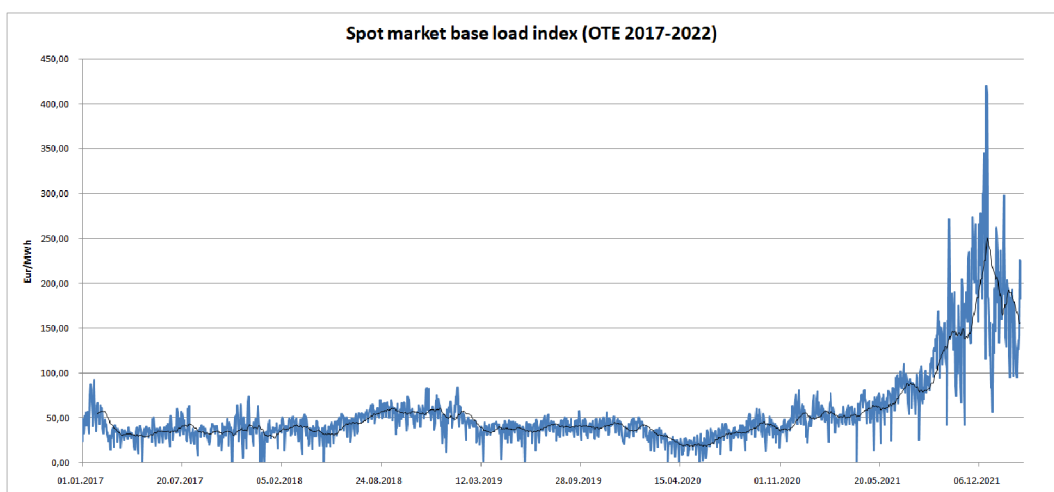

Fig. 8.12: Daily market prices of electricity (EUR), as given by OTE

Combining these price indexes with the second variable: the accordingly dated CZK/EUR exchange rates [26], gives us the base for determining correct feed-in prices for individual days between the present day and the beginning of 2017. The previous graph, however precise, contains too much data and needs to be simplified in order for the final feed-in values to be properly readable. For this purpose, we will consider the average feed-in prices for each month (2017 - 2022), derived from the original data set.

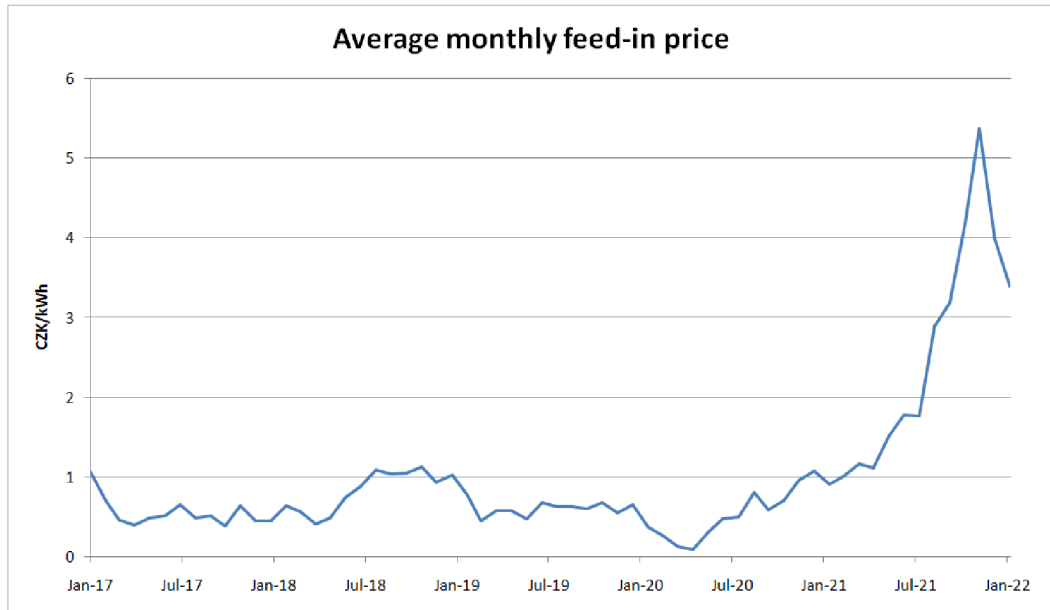

Fig. 8.13: Monthly average feed-in price (2017 - early 2022)

As we can immediately observe, the high point of electricity feed-in price is in not so distant past. During the month of December, 2021, the feed-in price climbed to the maximal historical value (given the measured interval) of 5,38 CZK per kWh. If we were to sell all of the unused energy produced by the previously discussed second hybrid iteration (see figure 8.5) at this exact price, it would represent an amount of 14 407 CZK. This number, however, is the result of an ideal state, and does not represent the real conditions. However, to be able to feed-in electricity at these prices, a contract needs to be established with ČEZ, for which the following conditions are specified:

- ČEZ needs to be the supplier of electricity in the location of consumption.
- Support in the form of "Green Bonus" is being utilized.
- The applicant is an owner of licence to generate electricity.
- The system is not connected as a micro-source according to § 28 of the Energy Act.

Firstly, the question of the supplier. As was already mentioned before, it is true that ČEZ is the current electricity supplier in the place of consumption. The remainder of the conditions represents several problems. Firstly, utilization of the Green Bonus. This, as previously mentioned (see section 5.2), requires for the owners to submit an application to the current market operator. The remaining two points represent the core of a possible problem. Under § 28 of Act No. 458/2000 Coll., also known as the Energy Act [13], a micro-source is defined as a system under 10 kW of installed power. Furthermore, it is precisely such "micro-source" that allows for the owner to set it up without the need for a licence to generate electricity. When considering the final system design, it is important to keep this distinction in mind as variants above 10 kWp will require further legal procedure. In turn, such system would be eligible for the feed-in application under ČEZ.

Systems under 10 kWp are therefore bound to an alternative, as them being considered a micro-source, prevents the establishment of the required contract. Luckily, ČEZ also offers such alternative, under their Electricity for Solar program (Elektřina pro Soláry) - EfS, which is specifically designed for smaller PV systems of installed power under 10 kW. The basic premise of this program can be interpreted as a virtual battery unit that works alongside the installed physical battery. The surplus electricity that is produced and fed into the grid. In return, the fed amount is then deducted from the amount of electricity taken from the grid, when it comes to billing. The main requirement in order to be eligible for this program is the upper limitation on the installed power of the system, which is 10 kW. In addition the system needs to be grid-connected in order to be able to realize the feed-in process. EfS also requires for the customer to have a valid contract with ČEZ on combined electricity supply services to the off-take point of the property. If the customer decides to apply and is approved, the current plan gets changed to the EfS plan and new tariff is applied. In our case, this would represent a change from the latest three year plan, under the D02d distribution rate, to the new EfS plan under the same rate, and a change in the cost per MWh [27]. Currently, under the price list from 21. 2. 2022 (which already differs from the latest applied price list from 1. 1. 2022, with the tariff price that is currently active for the household), the cost per MWh

(including tax and system services) is 6 455,8 CZK/MWh [11]. The current EfS price list under the same tariff shows the price of 7 664,6 CZK/MWh (including tax and system services) [27]. On the opposite side of the benefits, we therefore have an estimated 18.7 % increase in tariff price. The price per MWh of the feed-in electricity differs from the supply price value as it does not include system service and other charges and is instead set at 5 516.39 CZK/MWh [27]. This means that the feed-in electricity is valued at around 72 % of the set total price per MWh. This is important to note, as the cost deductions in billing due to the EfS are not at a 1:1 ratio of the surplus feed-in and the virtual battery supply.

While the concept of a virtual battery is by no means a bad choice, it is important to note that it comes with diminishing results and its maximum usability has a hard ceiling. If the system is able to produce larger amount of surplus energy for feed-in than it then requires to be supplied during (mainly) winter periods, the viability of the EfS program is significantly devalued. With a large enough surplus value, the virtual battery is no longer able to provide any benefits and therefore the excess electricity is simply wasted. With ČEZ as both distributor and supplier, the only other immediate option would be their feed-in tariff, which in turn requires for the system to not be a micro-source, and also the appropriate licence (as was discussed earlier in this section). If we instead wanted to explore more options outside of ČEZ, the current contract would have to be terminated and a new one under different company signed. One such locally available company offering both supply and feed-in options is the bezDodavatele joint-stock company. The main differences this contract would introduce is the unusual form of its billing system. Where ordinary contracts, such as the current one ČEZ, have fixed electricity prices, bezDodavatele operates with spot prices that change each hour, based on current state of the energy market under the Energy market operator [28]. The cost of grid supply therefore changes during the day and so does the feed-in price. This system presents both opportunities and problems, some of which can be demonstrated by examining an example of the daily market values shown in the following graph, with EUR values replaced with appropriate CZK values (based on exchange rate from the respective day [26]).

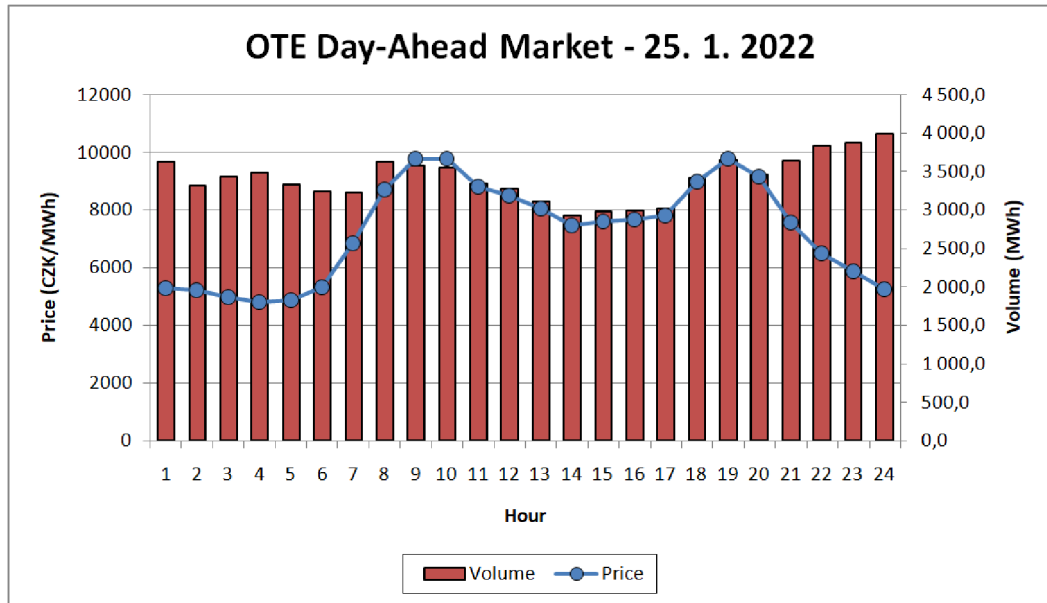

Fig. 8.14: Example of OTE daily market values (25. 1. 2022) [29]

Values shown in the graph represent the amount traded in MWh, which has impact on the general state of the market, but the more immediately important values represent the price per MWh. Upon observation of these price values, it can be noticed that they follow a certain trend of increases and decreases based on the time of the day. The data sets for different days all slightly vary in individual values, but the price curve trend remains consistent during the whole year, with high price values in the morning hours and again in the evening, divided by slight price decrease in between and then considerable decrease during the night. This means that any grid supply during the morning or evening periods will generally be of a higher price than possible feed-in during the middle of the day, when the PV surplus production is usually the highest. To make a more direct comparison, previously simulated values of energy flow elements can be used (see figures 8.6 through 8.10). Quick comparison reveals that the usual time during which a grid supply is needed, heavily coincide with these periods of increased electricity price. For that reason, when considering *bezDodavatele* as possible option, more detailed calculations are needed to determine the exact profitability of the potential feed-in. Due to the nature of the energy market and its prices changing hourly, it would be significantly difficult to predict an exact estimate for the bought and sold electricity. For this reason, an average values were calculated using the data from the last measured period of the market, February 2022. Additionally, as represented before (see figure 8.14), the electricity value fluctuates during the day. Given these facts supported by the yearly simulations of the various system variants, we have established two

different average values of the daily market prices. One as a base price for the feed-in and the second one for buying electricity. These values and their evolution during the month of February 2022 can be observed in the following graph:

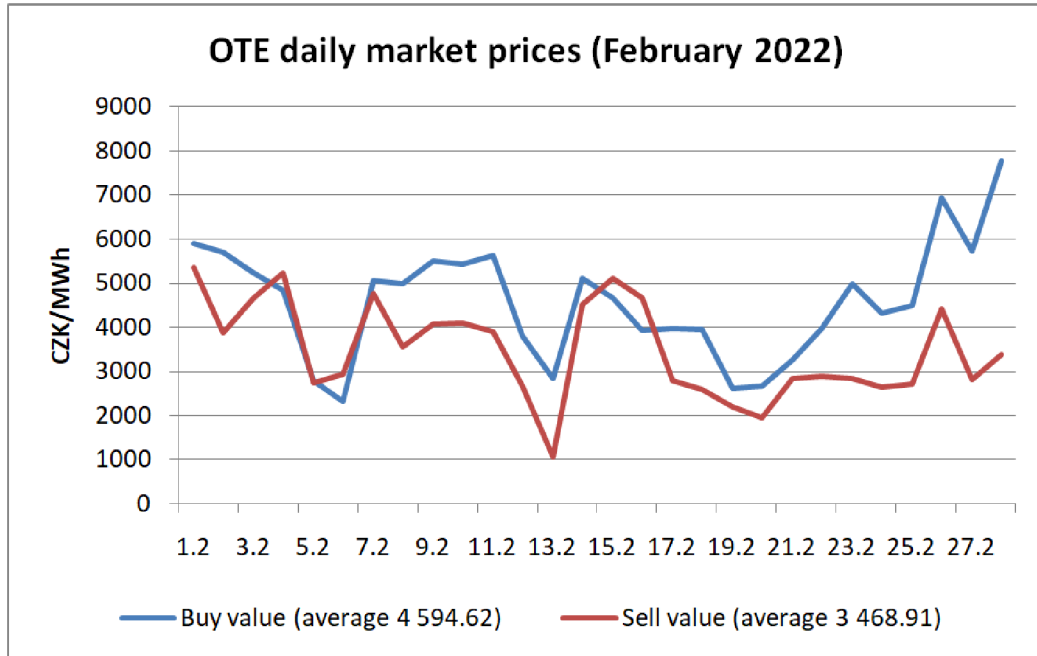

Fig. 8.15: OTE daily market values for buy and sell time-frames (February 2022) [29]

Arriving at two individual average values will prove vital when determining the estimated payments and profits associated with the more heavily feed-in based system variants under bezDodavatele instead of ČEZ as the supplier. Furthermore, as these values were determined by using the edge values of both low and high points during each day, it better illustrates the potential viability of the system, as both values represent the highest price per bought MWh and the lowest price per sold MWh.

9 Available market prices

As the available equipment is highly variable in price across different vendors, situations might occur, where the exact same type of module or battery will have drastically different purchase price. This can be more complicated by frequent price changes and even more factors outside of our control. For this reason, most proposed systems and their components will operate with average price values, gathered across available markets.

9.1 Roof installation prices

As an example of the compared data, the following table consists of various available PV modules of similar installed power values. The final module price (and following component prices) was obtained by determining an average value from the gathered data set.

Tab. 9.1: Example of prices for PV modules [36]

Manufacturer	Installed power [W]	Price [CZK]	Price/W _p [CZK]	Price/kW _p [CZK]
AEG	450	4 590	10.2	10 200.0
Longi	455	5 738	12.6	12 611.0
Longi	455	5 665	12.5	12 450.5
REGITEC	415	4 899	11.8	11 804.8
JINKO	450	5 490	12.2	12 200.0
PHONO SOLAR	450	5 140	11.4	11 422.2
Leapton	460	5 222	11.4	11 352.2
DAH Solar	450	4 825	10.7	10 722.2
JUST	450	5 490	12.2	12 200.0
DAH Solar	450	5 704	12.7	12 675.6
AMERI SOLAR	450	5 319	11.8	11 820.0
RISEN	450	5 690	12.6	12 644.4
Canadian Solar	455	5 516	12.1	12 123.1
Beyondsun	450	5 890	13.1	13 088.9
JA Solar	450	5 994	13.3	13 320.0

Considering the gathered data from numerous online vendors [36], the final average price per installed kWp of PV modules was found to be 12 042 CZK. To account for the sample size, the final numbers used for further calculations will be rounded to the closest hundred, leaving us, in this case, with the price of 12 000 CZK per kWp.

To add to the roof expenditures, the support structure of the installation also needs to be taken into account. Considering the state of the property, the chosen method for module mounting will be that of a three part support structure, made of roof mounting hooks, profiles and profile mounted brackets to hold the PV modules. Given the structure and dimensions of most PV modules, two horizontal profiles will provide support per vertically mounted module, or, alternatively, two vertical profiles supporting one horizontally mounted module. Given varying length of available profiles (up to six meters, using profile connectors where needed) the total amount and length of profiles will be determined per individual variant. As was previously mentioned, the profiles are to be mounted, using specialized hooks, with the amount of hooks corresponding to the number of panels per profile, with one additional hook on each profile. Finally, the PV modules themselves will utilize a system of central and side mounting brackets to hold them in place. Given the current state of the market [36], there is not a clear price distinction between the two types of brackets, therefore a single price value will represent either of the two. Lastly, the individual price averages were rounded to the nearest five.

Tab. 9.2: Price estimates of support structure components [36]

Component	Price [CZK]
Roof installed hooks	330
Al profiles	320/m
Profile mounted brackets	30
Profile connectors	50

9.2 Battery prices

Similarly to PV modules, the same process of gathering and determining average market price [36] (in this case per kWh) was employed, resulting in very similar initial number: 11 993.8 CZK per kWh which, when rounded to the nearest hundred, leaves us with the same price of 12 000 CZK per kWh. This calculation only considers

the individual battery units without the inclusion of any external attachments or enhancing modules, such as backup boxes or communication units. It is additionally assumed that the cabling required for battery-inverter (and battery-battery where required) connection is included with the battery units.

9.3 Inverter prices

As the inverters are a more directly specialized component of each system, with their parameters depending on those of other components, determining their average price is not as desirable and practical, as with other system elements. For this reason, average prices will be determined for specific inverter models that will be used in the final proposed variants. The price averages are yet again determined by the data gathered across numerous available vendors.

Tab. 9.3: Price estimates of used inverters [36]

Type	Price [CZK]
Fronius Symo Hybrid 3.0-3-S	52 033
Growatt 6000 TL3-S	24 097
Growatt 6000 TL3-X	26 517
Growatt 7000 TL3-S	26 880
Growatt 7000 TL3-X	30 910

Important fact to note is the average price for the first inverter. Although it is the highest among the researched range, the inverter itself is scaled for the smallest systems (compared to the other four). This can cause a disproportionate rise in expenses for small scale systems.

9.4 Safety element prices

To complete each system, a considerable range of safety measures is required, besides the essentials of any electrical circuitry (see section 6.1). Prices were gathered for the main protection means along with electricity meters, as those will also be required for the grid-connected hybrid systems.

Tab. 9.4: Price estimates of used safety elements [36]

Type	Price [CZK]
Surge protectors DC	2 080.00
Surge protectors AC	2 860.00
Fuse breakers	250.00
Electricity meters	1 400.00
Disconnectors	1 420.00

9.5 Cabling prices

As the potential locations of PV modules, inverter, batteries and other system elements are located at various distances from one another, it is important to take the cabling costs into account, as different system variants will require different length of different cable types. Furthermore, cable endings for the DC portion of the system may be required in different amounts, in order to conveniently connect the module strings. Average market prices for different types of cables and endings were calculated based on price per meter of length. Only basic cable options were considered, without taking into account different available complete cable sets, as those do not provide the flexibility of varying length.

Tab. 9.5: Price estimates of cabling components [36]

Type	Price/m [CZK]
4 mm ² - DC	35
4 mm ² - AC	90
Ground	80
Cable endings	55 (per piece)
Battery-inverter	500

10 Choosing the final variant of the system

In order to choose the most beneficial variation of the system, several of them will be proposed with different primary goals for each one of them, using all of the information previously discussed and acquired during different parts of this thesis. After, multi-criteria analysis will be used to select the one that is, in the best way, aligned with the wishes and expectations of the owner. Since the off-grid variants do not present enough benefits and would more than likely present more complications than necessary, they will not be included in the following analysis. The remaining items of the analysis will include several of the hybrid variants with focus on different properties and benefits, such as minimal investment or maximizing the use of available roof area.

10.1 Control element

For a complete and meaningful multi-criteria analysis, we also require a control element. For this purpose, the current state of the property will be used with the exception of switching the current contract with ČEZ. As all of the other system variants are using the most recently available supplier contracts, the lower prices of the current contract would not provide the most accurate comparisons. Therefore, the same class of contract was chosen under the most recent price list [11].

Tab. 10.1: Yearly cash flow without a PV system

CONTROL ELEMENT	[MWh]
Feed-in	-
Consumption	2.258
YEARLY [CZK]	
Payment for the reserved power according to the circuit breaker	1 989.24
Monthly payments	1 437.48
OTE activity	60.96
PER MWh [CZK]	
Supply	3521.1
Distribution	1 976.61
Tax	34.24
System fee	137.37
POZE fee	598.95
TOTAL [CZK]	
	17 641.43

10.2 Hybrid solution with minimal investment

The goal of this variant is to introduce such design that will deliver reasonable results, while heavily benefiting from the combination of available subsidies, the EfS program and small initial investment. When fully operational, the system should provide sufficient consumption coverage during high irradiance periods of the year with enough feed-in to cover the low irradiance periods around winter, utilizing mainly the EfS virtual battery program.

10.2.1 System design

Most important element of the minimal investment design is finding the ideal combination of installed power and proportionate battery. As the battery unit is going to be the more expensive component of the system, it is important to make an informed decision here. Starting with the PV modules, roof area availability should be of no concern here. It is vital to remember the important requirements for subsidy eligibility, mainly those of NGSP 2021 (see subsection 8.1.1), such as the correct sizing of installed power to the size of selected battery. Given a brief market overview to determine suitable, available PV modules, 450 Wp model LR4-72HPH-450M of the manufacturer Longi were used, as this particular models combines availability with reasonable cost to power ratio at most local vendors. With the type of modules determined it is time to set the installed power to battery size ratio and fit the resulting installed power with appropriate inverter. Considering the goal of minimizing costs, combined total of 6 modules will make up this first system iteration. This number helps satisfy several requirements:

- Since the installed power amounts to 2.7 kWp, it satisfies the NGSP 2021 eligibility requirement for the system to have at least 2 kWp.
- 2.7 kWp of installed power is enough to fit the system with Fronius Symo Hybrid 3.0-3-S, a three phase hybrid inverter, which eliminates the need for a separate battery inverter, further reducing needed initial investment.
- Being under 10 kWp classifies the system as a micro-source, which significantly simplifies the setup process

Placement of only 6 modules means minimal issues with available space. All of the modules can be connected as a single string of six with vertical orientation.

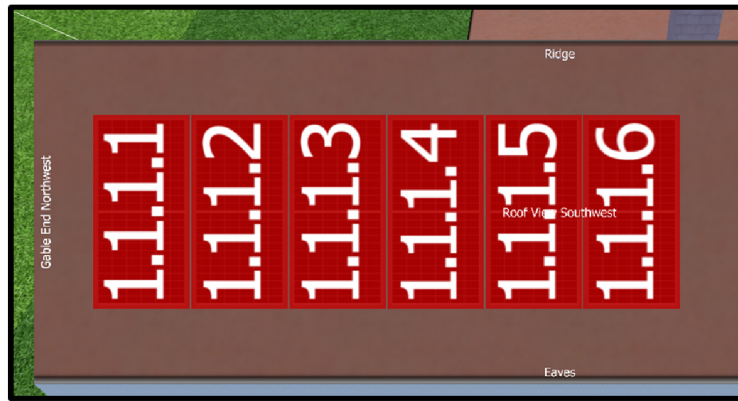

Fig. 10.1: Module placement of the minimal investment variant

As was previously mentioned a 3 kW inverter was added, which makes the sizing factor of 90%. This relatively edge-case solution was chosen as the availability of such small scale hybrid inverters is not that extensive. With an under-sized module system, in comparison to the inverter, the overall efficiency might see marginal drops, however, the values of such differences should not have a meaningful negative impact on the working of the system, as we will be able to see in the next subsection. Using a single string also makes the cabling procedure relatively easy to realize. For better understanding of the system structure, we can take a closer look at the following schema:

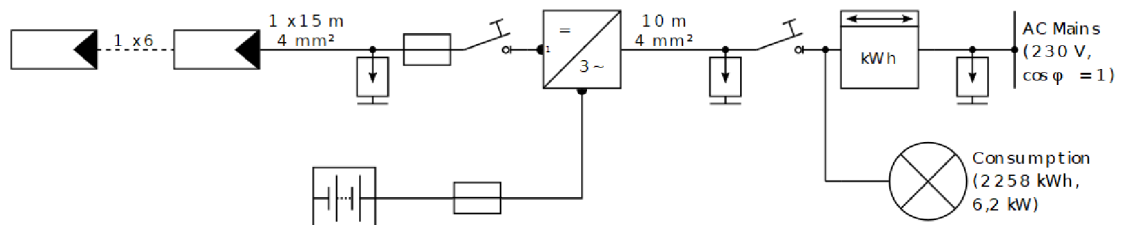

Fig. 10.2: Structure diagram of the minimal investment variant

We now have a clear representation of the final form of the system, complete with all important connections and safety elements. First thing we can notice is the DC side of the system on the left side, comprised of the PV module array (a single string), with both a fuse breaker and surge protector. Using a fuse based breaker rather than a plain breaker requires the additional cost of fuses, but provides us with another way for the system to be disconnected from the array that can not be easily switched back on in the case of required maintenance. The last noteworthy element on the DC side of the system would be the disconnect switch. The total length of

the DC cabling (positive and negative) was set to 30 meters to accommodate for the distance from the roof located PV array to the inverter. In contrast, the Solax T 3.0, a 3.1 kWh battery unit can be located right next to the inverter, which makes its cabling requirements next to minimal. The inverter-battery section is, again, completed with a fuse based breaker. On the AC side of the inverter, we can notice similar setup of an AC side surge protector and another circuit disconnecter, for complete disconnection of the system from the household and grid. The final surge protector is located at AC mains for additional surge protection.

10.2.2 System analysis

Resulting system can then be simulated to project the estimated yearly values of energy flow. These can be seen in the following diagram:

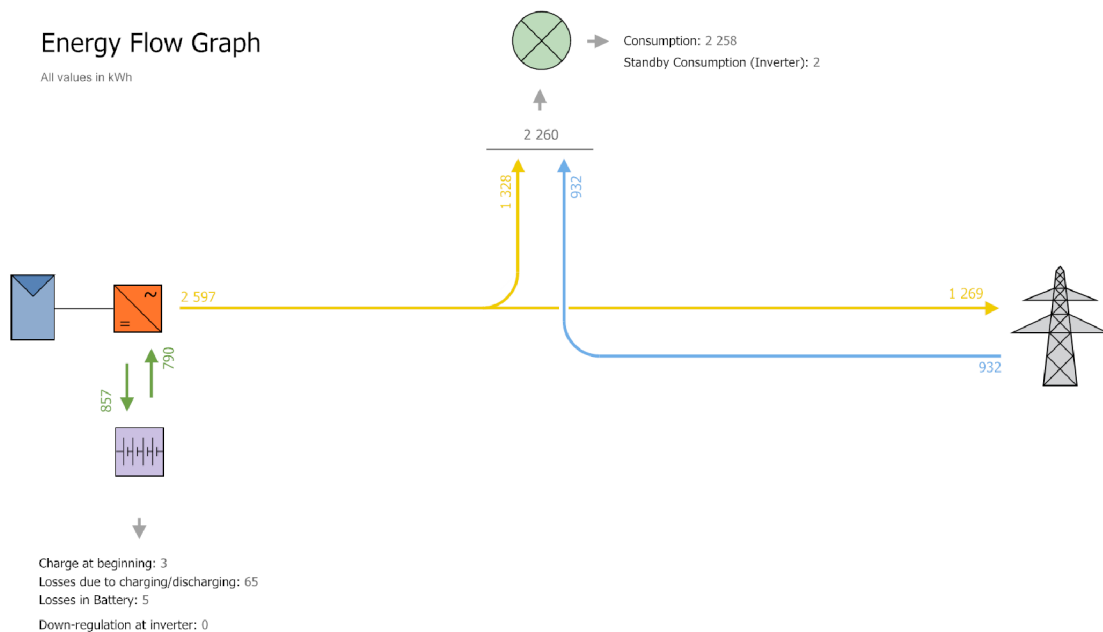

Fig. 10.3: Energy flow diagram of the minimal investment variant

Several observations can be made from the individual values. Firstly, the system is operating at 51 % own power consumption, with 1 269 kWh of predicted yearly grid feed-in. To contrast this, 932 kWh/year is supplied by the grid. This means that for the purpose of the virtual battery by EfS, we are operating at around 133 % coverage of grid supply by the total feed-in. Under such conditions, fixed price for the yearly supplied electricity would only consist of distribution, systemic and other mandatory charges. The specific price per kWh can then be calculated using the provided price list by ČEZ.

Tab. 10.2: Yearly cash flow of the minimal investment variant

MINIMAL INVESTMENT VARIANT		[MWh]
Feed-in		Sufficient
Consumption		0.932
YEARLY [CZK]		
Payment for the reserved power according to the circuit breaker	1 989.24	
Total monthly payments	2 395.8	
OTE activity	60.96	
PER MWh [CZK]		
Supply	-	
Distribution	1 995.17	
Tax	34.24	
System fee	112.89	
POZE fee	598.95	
TOTAL [CZK]		
	7 000.85	

Comparing the previous table to the control element (see table 10.1), we can see an overall decrease in the total yearly payment. The utilization of the virtual battery EfS program means that with sufficient feed-in amount, the supply portion of payments per MWh can be omitted from the calculations. However, comparing the rest of the charges to the control element, we can see a significant increase of 40%. This is caused by the introduction of the "virtual battery fee", with monthly payments of 199,65 CZK. The total yearly payment is then decreased by little over 60% compared to the control element, with a total yearly consumption of only 41%.

Tab. 10.3: Estimated initial investment of the minimal investment variant

Item	Type	Amount [-]	Price [CZK]
PV modules	Longi LR4-72HPH 450 Wp	6	32 400.0
Inverter	Fronius Symo Hybrid 3.0-3-S	1	52 033.2
Battery	Solax T 3.0 - 3.1 kWh	1	37 200.0
Support structure	Support structure + material	1	12 300.0
Safety elements	Combined safety el. setup	1	14 620.0
Cabling	Complete cabling	1	6 735.0
Paperwork	Project, revision	1	10 000.0
Work	Assembly and electrical work	1	16 160.0
Subtotal			181 448.2
NGSP 2021			108 868.9
TOTAL			72 579.3

The initial cost of the combined system components also needed to be calculated. The previous table (see table 10.3) represents the cost of the main components that

will largely differ from variant to variant, such as varying lengths of different cable types, and differently sized support structure components. In contrast, based on the size and total cost of the system, the NGSP 2021 subsidy can be determined (see section 8.1). Given the relatively low subtotal component costs and the high available subsidy, covering up to 60% of the total initial costs, the resulting system cost is estimated at 72 579.3 CZK. This price reflects the low investment nature of the proposed system and should be contrasted by the later variants with significantly larger initial costs.

10.2.3 Economic analysis

Using the previously determined values of initial costs and yearly estimated cash flow, the total accrued cash flow diagram can be simulated with all of the necessary parameters, to project the potential return on investment over the span of 21 years. This is assuming the same tariffs and energy market conditions over the entire span.

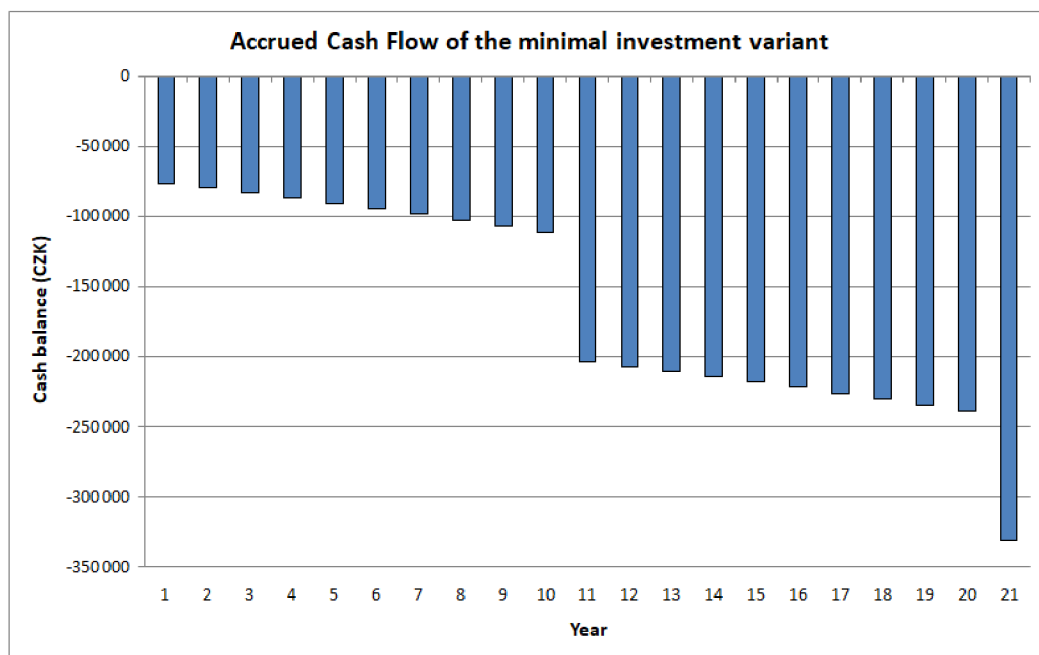

Fig. 10.4: Estimated cash flow of the minimal investment variant

The data readings from the simulation results may not initially look pleasing, as the total cash flow resides in negative numbers for the entirety of the 21 year observation period. Additionally several more purchases are visible in the graph, marking the replacement of both the battery and inverter, after their respective warranties run out or after the initial warranty extension period, as per the data-sheets and

technical documentation provided by their manufacturers [30] [31]. This might not very well be the case during real usage, and the system might still be fully functional within reasonable bounds, however, it presents the most easily quantifiable and also uniform option for this and the remaining system variants.

As it stands now, the system remains in negative numbers, and should therefore not be perceived as a viable alternative to the current electricity plan. However, upon comparison of these two variants and their accrued cash flow numbers, the merit of the minimal investment variant can be seen more clearly.

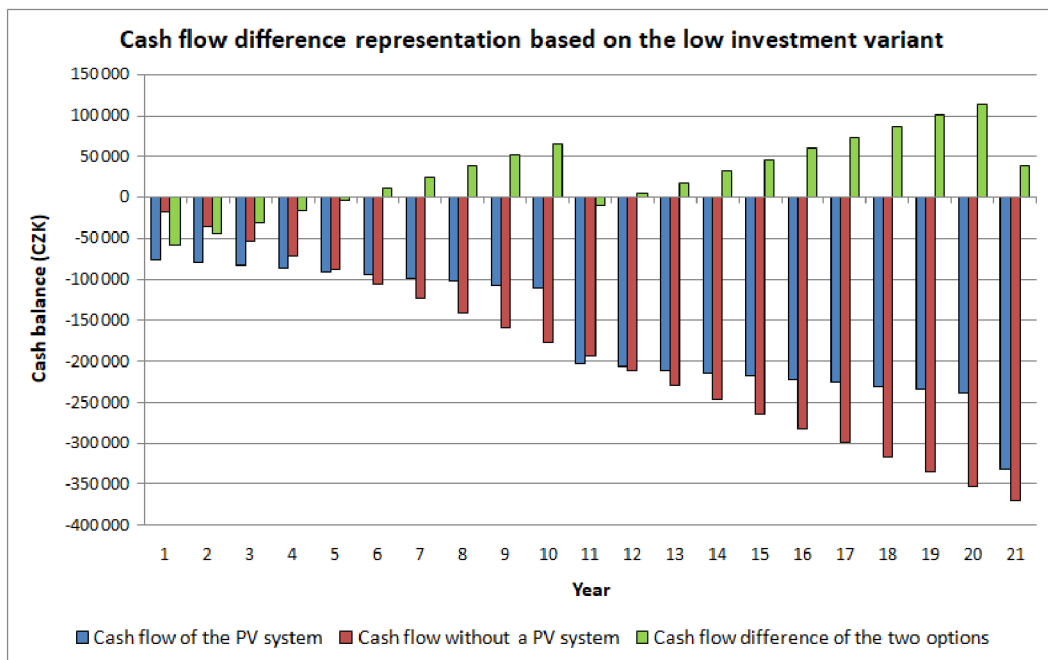

Fig. 10.5: Cash flow comparison for the minimal investment variant

Compared to the control element of no PV system, the minimal investment variant can see a notional return on investment in the sixth year of its operation, where the accumulated yearly electricity costs of the current tariff exceed the accumulated costs of the first PV system variant. This is achieved by the combination of low yearly electricity costs, relatively low initial cost and the estimated yearly savings on electricity, thanks to the virtual battery tariff. Slight fall back to negative numbers can (potentially in reality) be seen during the eleventh year, after the warranty of both the battery and inverter expires, and the requirement for their replacement arises. Although the return on the initial investment is present, it can be significantly improved by scaling the system up in size, while also exploring different options for dealing with excess unused electricity generated by the system.

10.3 Balanced hybrid solution

Second iteration of the proposed system should serve as a sort of middle ground between the minimum and maximum approach. Since the minimal investment variant already managed to fully cover the virtual battery usability, a different energy supplier should be considered for this one, in order to directly benefit from the feed-in opportunities of the system. For this purpose, the bezDodavatele program of spot price buying and selling will be used for the economical calculations of this variant.

10.3.1 System design

As we should be able to capitalize on the feed-in more directly, we will try and cover as much available area of the south-western facing roof as possible. Using the same type of panels as the previous iteration, in combination with different inverter, should provide us with a total of two strings, consisting of 8 and 7 modules respectively.



Fig. 10.6: Module placement of the balanced variant

Due to the greater physical load of the modules and the supporting structure, we are assuming ideal static conditions of the building. Furthermore, the complete installation is situated more towards the eaves, rather than the ridge, with more space on both sides, to account for lightning rod structure. Due to the multi-string nature of the system, cabling is slightly more complicated than the previous variant, however, the overall structure past the individual strings, remains in similar nature, with north-western side roof grommet, leading the cables downwards towards the inverter. The main difference in structure can be observed at the safety element level, with the DC side protection being practically duplicated for each of the strings. Additionally a DC side inverter located surge protection is also added.

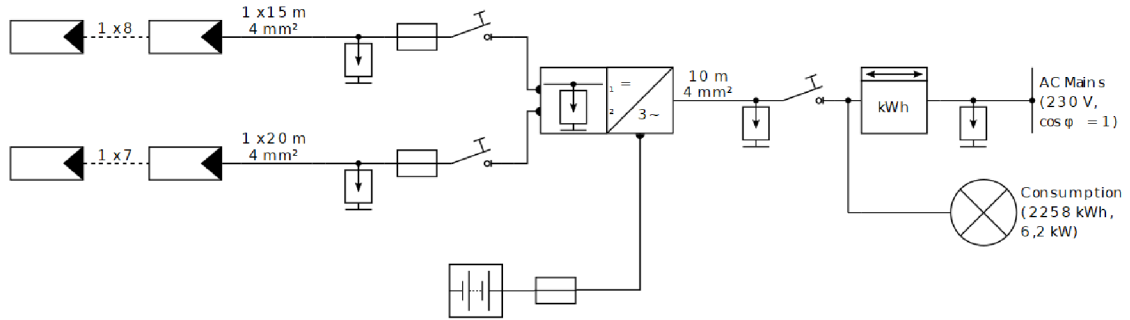

Fig. 10.7: Structure diagram of the balanced variant

10.3.2 System analysis

Compared to the previous variant, the benefit of 9 additional PV modules significantly improves the yearly performance of the simulated system. Battery capacity was also expanded, replacing the 3.1 kWh unit of the previous iteration with a combination of the same three batteries, leaving the system with a combined 9.2 kWh unit. As the combined installed power of the PV modules is now 6.75 kWp, this remains in line with NGSP 2021 requirements (see subsection 8.1.1), while also greatly enhancing the self-sufficiency of the system.

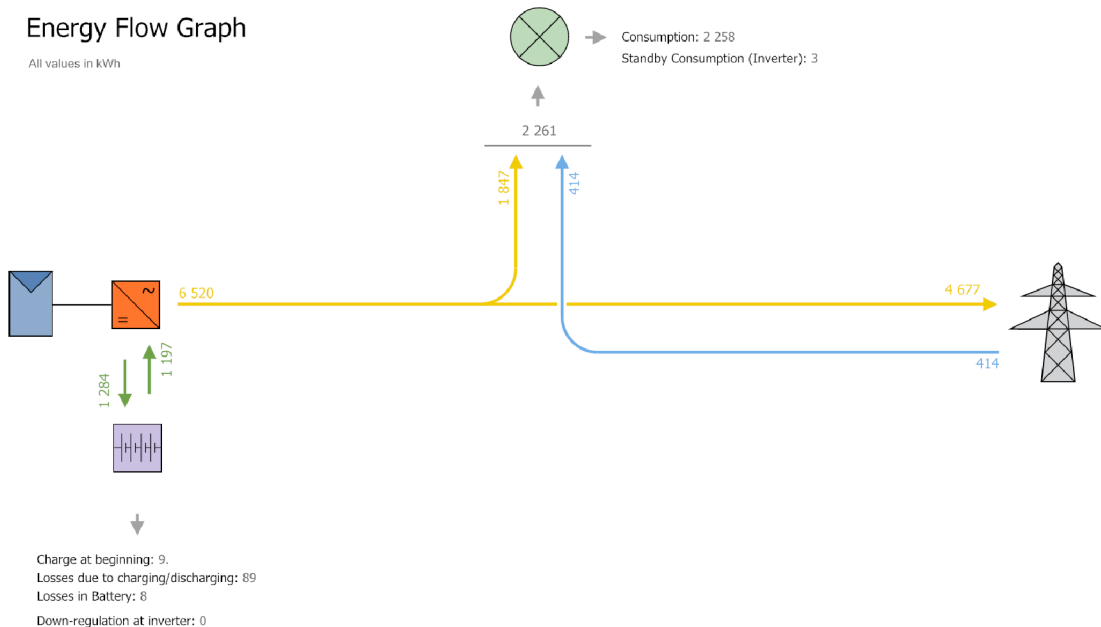

Fig. 10.8: Energy flow diagram of the balanced variant

With the combined usage of the panel arrays and batteries, the total estimated amount of required grid-supply electricity is cut to only 20% of the total consumption coverage. In addition, the yearly surplus generation allows for a sizeable feed-in, amounting up to 4 677 kWh. Since the price of both grid supply and feed-in are now based on spot market prices, the calculations are slightly different, using the methods described in previous sections (see section 8.5).

Tab. 10.4: Yearly cash flow of the balanced variant

BALANCED VARIANT		[MWh]
Feed-in		4.677
Consumption		0.414
YEARLY [CZK]		
Payment for the reserved power according to the circuit breaker	1 989.24	
Total monthly payments	1 437.48	
OPE activity	56.76	
Total daily payments	2 649.9	
PER MWh [CZK]		
Supply	4 594.62	
Distribution	1 995.17	
Tax	34.24	
System fee	112.89	
POZE fee	598.95	
TOTAL [CZK]		
	9 170.43	
FEED-IN GROSS PROFIT [CZK]		
	16 224.09	

With the larger amount of feed-in and different energy supplier, the system is now able to generate yearly profits in addition to the reduction in yearly electricity payments. Comparing the total yearly payment with the previous iteration, several irregularities can be noticed. Firstly, although the total yearly payments differ by only roughly 20%, the grid-covered consumption values differ much more clearly, where this iteration presents only around 40% of the grid-covered consumption from previous iteration. This can be explained by the high static yearly fees of the new iteration, combined with the re-introduction of the supply cost payments per MWh. Regardless of the price increases, the feed-in process is able to generate estimated 16 224 CZK, leaving us with an estimated yearly profit of roughly 7 053 CZK.

Tab. 10.5: Estimated initial investment for the balanced variant

Item	Type	Amount [-]	Price [CZK]
PV modules	Longi LR4-72HPH 450 Wp	15	81 000
Inverter	Growatt 6000 TL3-S	1	24 097.5
Battery	Solax T 3.0 - 3.1 kWh	3	110 400
Support structure	Support structure + material	1	29 640
Safety elements	Combined safety el. setup	1	18 370
Cabling	Complete cabling	1	10 135
Paperwork	Project, revision	1	10 000
Work	Assembly and electrical work	1	24 240
Subtotal			307 882.5
NGSP 2021			- 184 729.5
TOTAL			123 153

Observing the cost of individual component categories, it can be noticed that although this variant is using a different inverter scaled for larger systems, its cost is significantly lower compared to the previously used inverter. This cost disparity is then balanced by the large battery size, as well as by the price for the PV modules. The maximum amount of subsidy that the system would be eligible for was in this case 215 000 CZK, however, given the subtotal cost of the components, this would greatly exceed the maximal allowed 60% of the cost. The 60% is in this case 184 729.5 CZK and so it will represent the eligible subsidy amount.

10.3.3 Economic analysis

Simulating the annual cash flow of the system (see figure 10.9), reveals a more positive results than those of the previous variant. Given the larger initial investment, the pure return on investment is delayed until seventh year of operation, during which we enter positive accrued cash flow values. Same as the previous variant, the battery unit and the inverter will be renewed during the eleventh year and again during the twenty-first, in accordance with the data-sheet warranty (basic and optional) periods [31] [32]. Despite the larger initial investment, it is estimated that the system should be able to fully pay for itself over the period of 7 years, during which the combined resources from the grid feed-in and the electricity savings made possible by the PV generation, exceed the purchase price of the system.

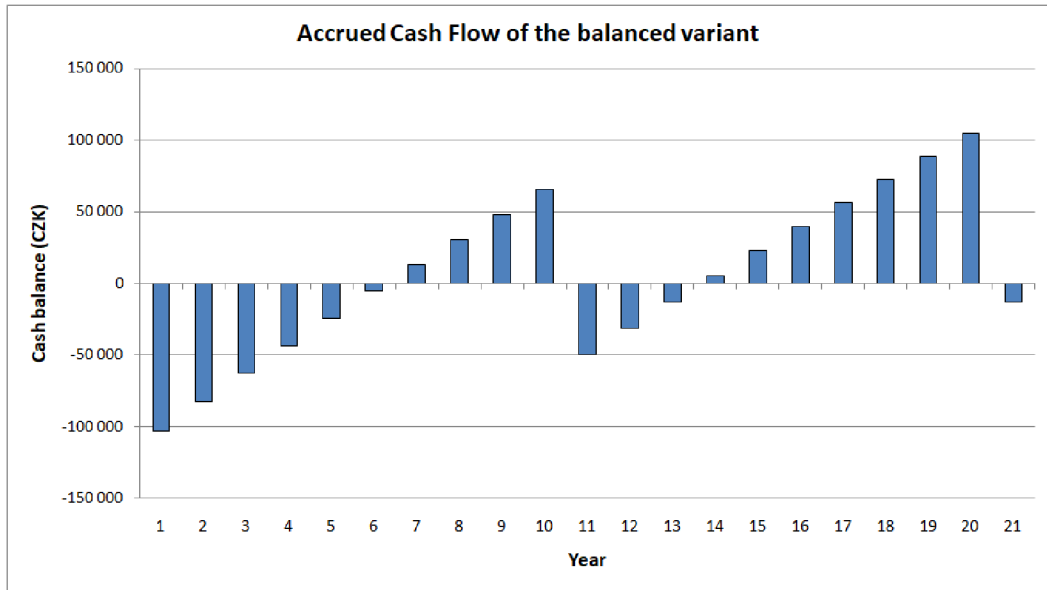

Fig. 10.9: Estimated cash flow of the balanced variant

Although the pure return is more clearly visible for this variant than for the previous one, we can again compare the cash flow states of both this variant and the control element over the simulated period of 21 years.

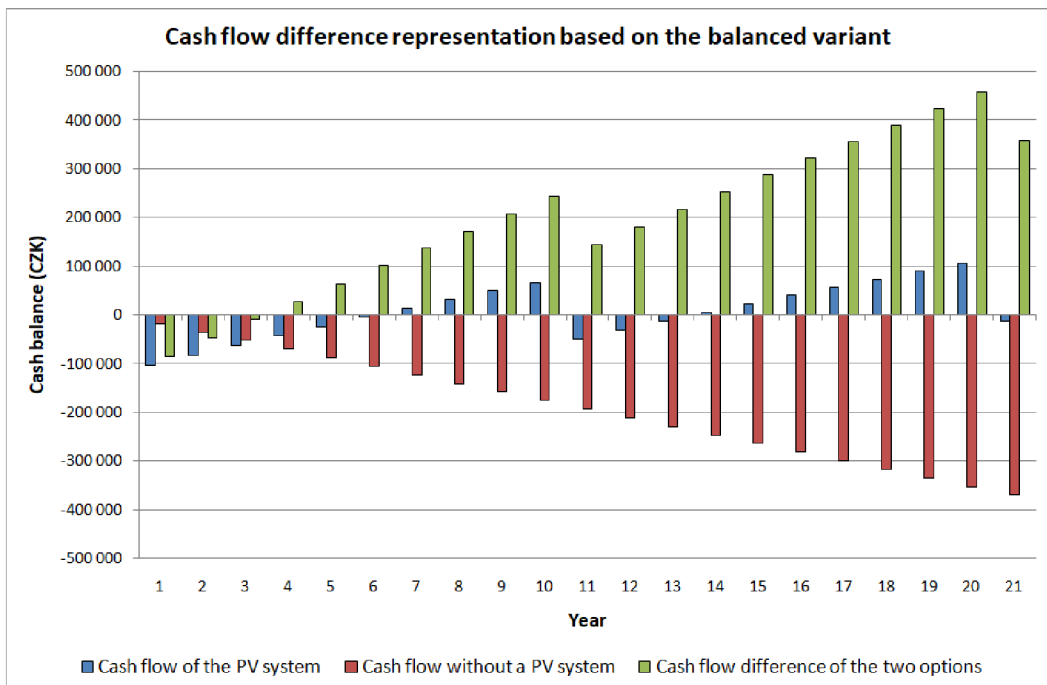

Fig. 10.10: Cash flow comparison for the balanced variant

From the previous figure (see figure 10.10), the relative profitability (when compared to the option of no PV system), is much more recognizable. If we only take into account the pure profit of the system on its own, we are still reaching negative values of cash flow during the points of equipment replacement, even at the 21 year mark. However, when contrasted with the cash flow without a PV system, the true quality of such system surfaces. The system is not (under current conditions, however ideal) something we should be considering as an additional source of income, but rather as way of saving a rather noticeable amount of money in the future.

10.4 Hybrid solution with maximized gain

In order to maximize the potential output of the system, we will try and cover as much suitable roof area as possible in order to fully cover the consumption during high irradiance periods and have enough generated surplus energy, to realize larger scale feed-in. As with the previous iteration, the larger scale of the system presents little to no benefits of the EfS program, and as such, this variant will also be based on the bezDodavatele program of spot price buying and selling.

10.4.1 System design

For this variant, both suitable (south-western and south-eastern facing) roof areas were fully covered with PV modules in order to maximize the potential gain of the system. The resulting installation was split into two strings (15 and 6 panels) and connected to a larger scale inverter. Completing the system is an adequately sized battery unit with 11.5 kWh combined capacity. This combination is also in order with the NGSP 2021 requirements for system sizing (see subsection 8.1.1). While a system setup of this scale presents even larger initial investment, the combination of both roof areas should provide more optimal electricity generation as both module arrays are facing different sides.

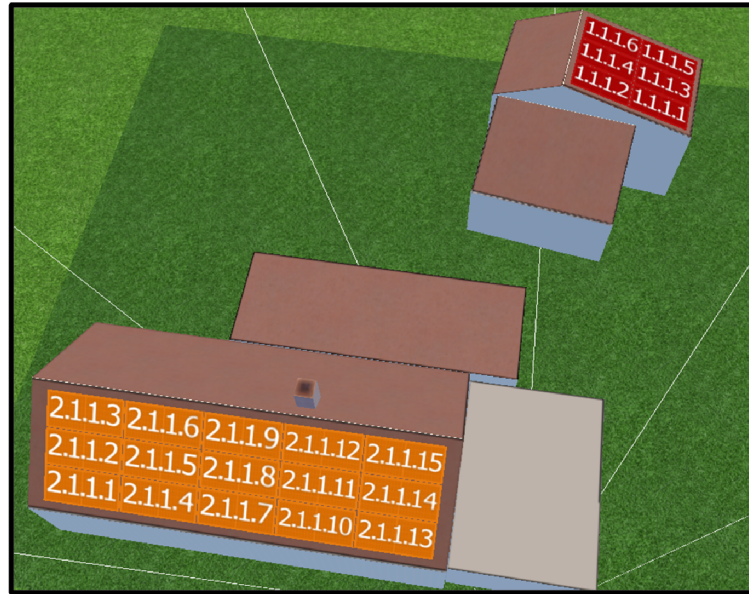

Fig. 10.11: Module placement of the maximized gain variant

From the figure above, the representation of the string locations can be observed. As the second string is located on a different building, some adjustments will be made during the construction of the system.

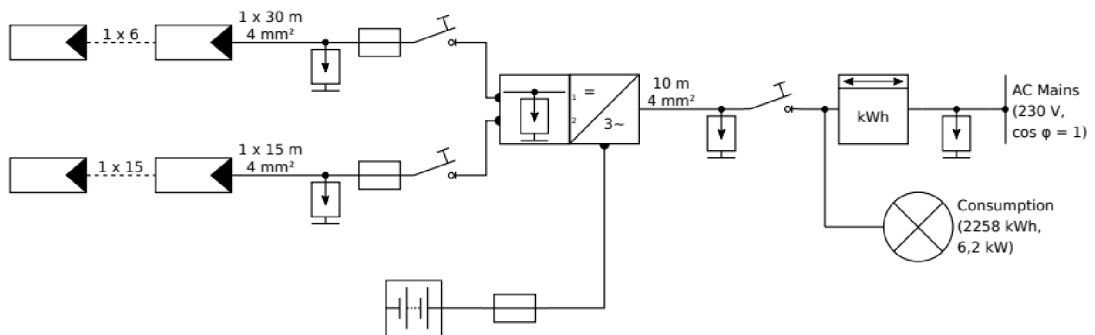

Fig. 10.12: Structure diagram of the maximized gain variant

The system structure is practically identical to that of the previous variant, with the main difference being the total length of the DC cabling. As one of the strings is located on an entirely different roof, longer cabling is required. Although the length of the cabling on one string is doubled, it can still be accommodated by wires of 4mm in diameter, with estimated cable losses securely under 1%, according to the simulations.

10.4.2 System analysis

Comparing this variant with the previous ones shows a large increase in the annual feed-in estimates, as well as reduction in required grid supply by almost a quarter, thanks to the combination of more PV modules and bi-directional orientation of the system.

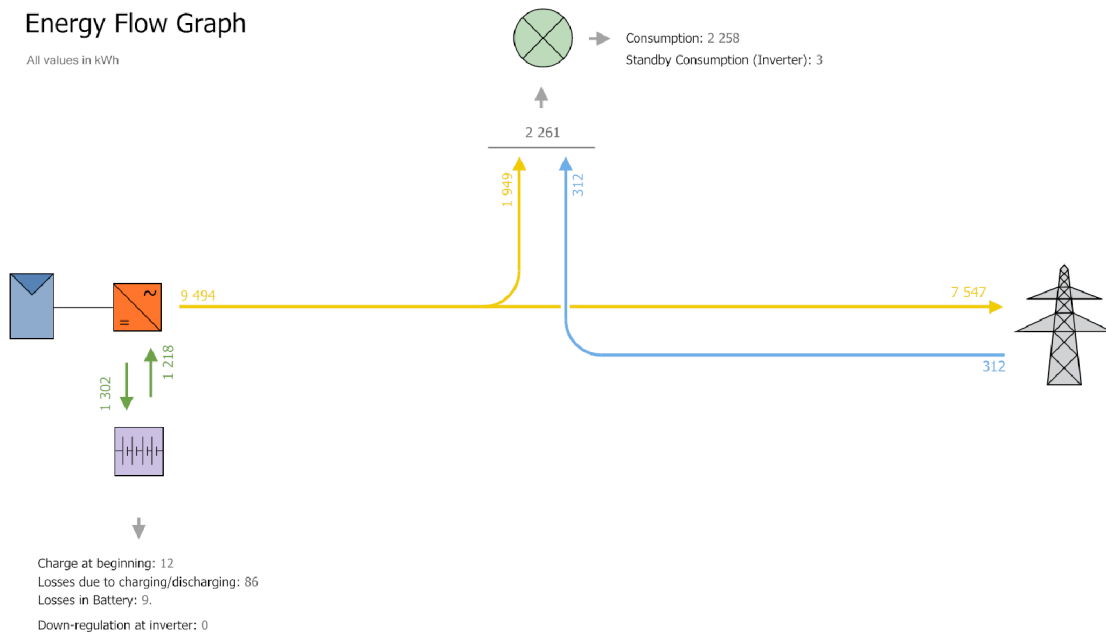

Fig. 10.13: Energy flow diagram of the maximized gain variant

The over-scaling of the system results in estimated 21% of own consumption, where the rest of the generated electricity can then be sold at market spot prices. Getting into the combined annual payments and possible profits, we can observe the yearly cash flow table below (see table: 10.6):

Tab. 10.6: Yearly cash flow of the maximized gain variant

MAXIMIZED GAIN VARIANT		[MWh]
Feed-in		7.547
Consumption		0.312
YEARLY [CZK]		
Payment for the reserved power according to the circuit breaker	1 989.24	
Total monthly payments	1 437.48	
OTE activity	56.76	
Total daily payments	2 649.9	
PER MWh [CZK]		
Supply	4 594.62	
Distribution	1 995.17	
Tax	34.24	
System fee	112.89	
POZE fee	598.95	
TOTAL [CZK]		
	8 422.17	
FEED-IN GROSS PROFIT [CZK]		
	26 179.86	

With the estimated decrease in grid-covered consumption, it should be no surprise as to why the total yearly payments are also showing a decrease. However, the estimated decrease is not directly adequate to the grid-supplied consumption difference, as most of the actual cost is tied to the yearly payments, independent on the supplied amount of kWh. Yearly feed-in profit has undergone a much more significant increase in amount, exceeding the estimated profits of the previous iteration by 9 955.8 CZK. With this significant increase in profits just from the feed-in alone, we must now also compare the initial investment size with the previous iterations.

Tab. 10.7: Estimated initial investment for the maximized gain variant

Item	Type	Amount [-]	Price [CZK]
PV modules	Longi LR4-72HPH 450 Wp	21	113 400.0
Inverter	Growatt 7000 TL3-S	1	26 879.9
Battery	Solax T 3.0 - 5.8 kWh	2	138 000.0
Support structure	Support structure + material	1	41 560.0
Safety elements	Combined safety el. setup	1	18 370.0
Cabling	Complete cabling	1	12 590.0
Paperwork	Project, revision	1	10 000.0
Work	Assembly and electrical work	1	32 320.0
Subtotal			393 119.9
NGSP 2021			- 225 000
TOTAL			168 119.9

By looking at the previous table (see table: 10.7), the most significant increases in cost fall under the PV module, battery and support structure category. Although the second PV array is on an entirely different roof, the estimated price of additional required cabling is not that significant when compared to other components. We can observe an increase in estimated total costs (before subsidy application) by nearly 90 000 CZK. Utilizing the subsidy, however, it is possible to reduce the final cost difference by half to around 45 000 CZK, with the total combined initial cost being estimated at 168 119.9 CZK

10.4.3 Economic analysis

The increase in initial investment is immediately projected in the accrued cash flow graph for this variant. Compared with the previous variant, we are able to see a faster estimate on return of investment, with positive numbers first appearing during the sixth year of operation, just from the PV system alone. Furthermore, the estimated additional costs after 10 years (according to the proper data-sheets) [33] [34] puts the system in the negative cash flow numbers ever so slightly. Accommodating for the simulated prediction of panel power decrease over the span of the measured period, the system still manages to remain in positive numbers during the second replacement after 10 more years.

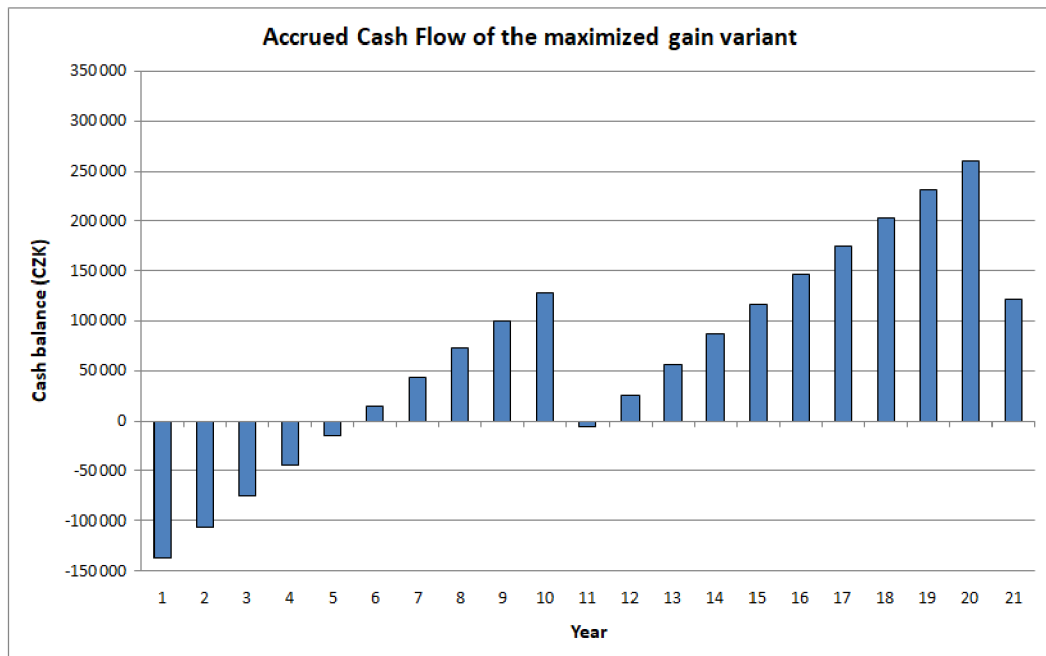

Fig. 10.14: Estimated cash flow of the maximized gain variant

When compared to the variant of annual payments without a PV system, this iteration shows a positive difference in cash flow as soon as during the fourth year of operation, with only positive numbers from that point onward and reaching a difference as high as 600 000 CZK during the twentieth year of operation.

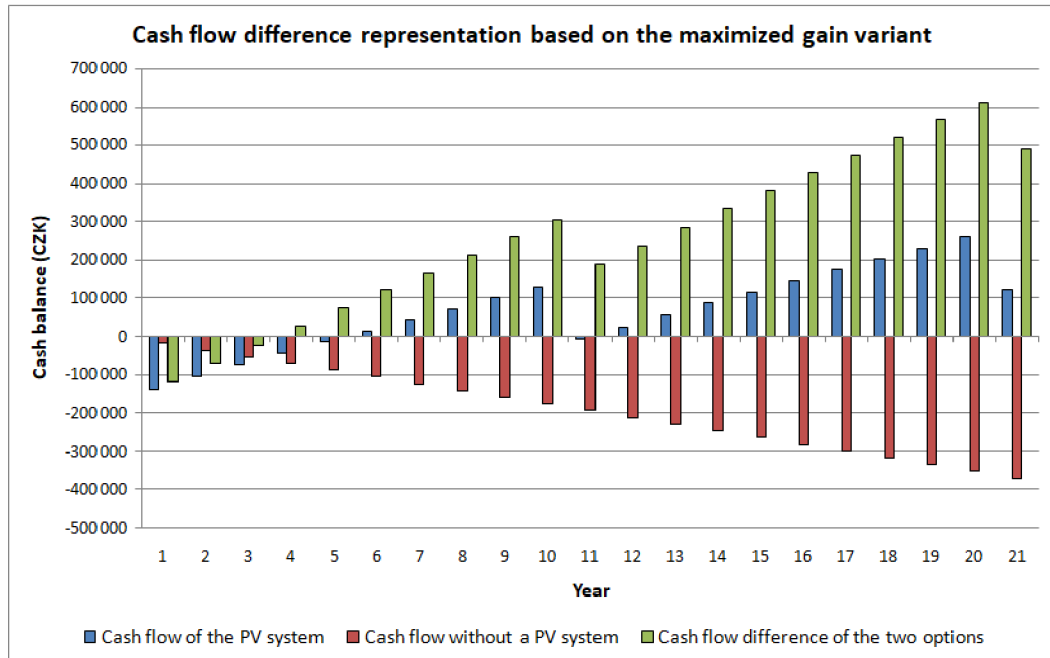

Fig. 10.15: Cash flow comparison for the maximized gain variant

This one and all the previous variants only project estimated values, based on current market prices and energy cost values. With the current volatility of the market, it is difficult to make a highly certain prediction of the cost evolution in the near future. With this in mind, we can now attempt to select a system variant that should be most suitable, given parameters, requested by the owners.

11 Multi-criteria decision analysis

The analysis is based on several criteria in order to determine the solution that would be the most suitable one for the owners. The decision criteria will include the following:

- Size of initial investment
- Comparative cash flow balance after 10 years
- Rate of initial investment return
- Additional costs during the operation period

By setting up these criteria, we are then able to create a hierarchical structure of three levels. The entire process of this analysis is based on the analytic hierarchy process of R. W. Saaty [35]. The first level denotes the goal of the analysis, with the second level being its criteria. The last level then represents the individual variants and their ties to the criteria above.

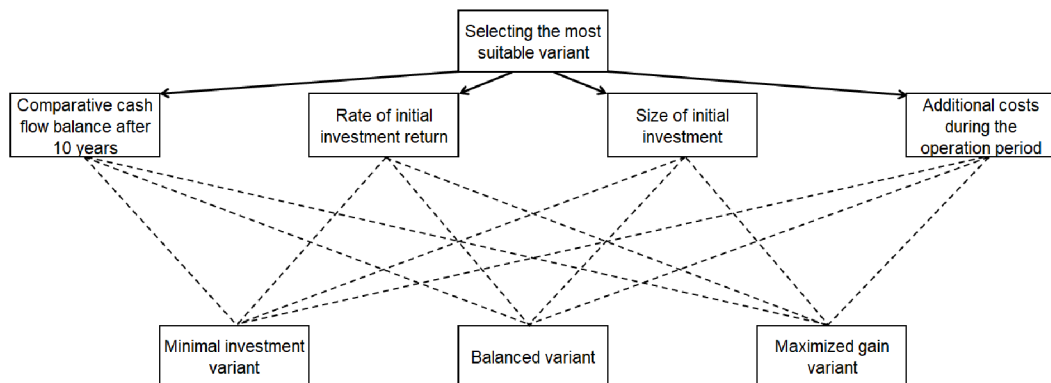

Fig. 11.1: Hierarchical structure of the analysis

The first step of the actual analysis is to create a comparison table, consisting of all the criteria in order to weight them against one another. We do this, by assigning each criteria pair a number based the importance of one over the other, with 1 representing an equal importance, 5 representing strong importance and 9 representing extreme degree of importance. As a result, we obtain a table that can then give us the values required for assigning individual criteria their total weight over the decision making process.

Tab. 11.1: Paired comparison table of the individual criteria

Selecting the most suitable variant	Comparative cash flow balance after 10 years	Rate of initial investment return	Size of initial investment	Additional costs during the operation period	Total weight
Comparative cash flow balance after 10 years	1.00	3.00	5.00	6.00	0.5865
Rate of initial investment return	0.33	1.00	1.00	2.00	0.1733
Size of initial investment	0.20	1.00	1.00	2.00	0.1537
Additional costs during the operation period	0.17	0.50	0.50	1.00	0.0866

The same approach is then taken for all of the variants under all of the four criteria, again, assigning numbers based on the importance of one over the other. In the following table, the variant names were substituted with letters, under the following key:

- A . . . Minimal investment variant
- B . . . Balanced variant
- C . . . Maximized gain variant

Tab. 11.2: Paired comparison table of the individual variants

Comparison after 10 y.	A	B	C	Investment return	A	B	C
A	1.00	0.25	0.20	A	1.00	0.14	0.11
B	4.00	1.00	0.50	B	7.00	1.00	0.50
C	5.00	2.00	1.00	C	9.00	2.00	1.00
Initial investment	A	B	C	Additional costs	A	B	C
A	1.00	2.00	3.00	A	1.00	2.00	3.00
B	0.50	1.00	2.00	B	0.50	1.00	2.00
C	0.33	0.50	1.00	C	0.33	0.50	1.00

When assigning the comparative numbers, it is important to uphold certain consistency, so that the results may be as accurate as possible. For our previous calculations, the consistency ratio was calculated to be 1.2%. This satisfies the recommended value of less than 10%, under the guidelines of R. W. Saaty [35]. With

all of the required weight values, their matrices can be multiplied to receive the final percentage values of each variant, resulting in the following matrix calculation:

$$\begin{bmatrix} 0.0982 & 0.0577 & 0.5390 & 0.5390 \\ 0.3339 & 0.3468 & 0.2973 & 0.2973 \\ 0.5679 & 0.5955 & 0.1638 & 0.1638 \end{bmatrix} * \begin{bmatrix} 0.5865 \\ 0.1733 \\ 0.1537 \\ 0.0866 \end{bmatrix} = \begin{bmatrix} 0.1971 \\ 0.3274 \\ 0.4756 \end{bmatrix} \quad (11.1)$$

As can be seen from the results, the variant with the highest weight of 47.5% is variant C (the maximized gain variant), with variant B (balanced variant) in second place with 32.7%. Lastly, variant A (minimal investment) ended up in third place with only 19.6%. The outcome of the analysis therefore supports the maximized gain variant of the PV system as the most suitable one, given the assessment criteria and their weights.

12 Conclusion

This thesis as it is serves the purpose of theoretical introduction to the topic of photovoltaic systems as well as a starting point for the practical part, in which the first iteration, a fully self sufficient off-grid system, is explored.

The main aim of the first part was to explore the theoretical phenomena behind photovoltaic power systems for household applications. It covers all the important components of this topic, such as the photovoltaic effect itself, or the individual components of a photovoltaic power system. A simple market research was also done for the most vital parts of any off-grid PV system, noting important information about locally available products and comparing their properties.

In the second part, a real location was selected as a basis for practical simulation work regarding possible photovoltaic system installations. The main target was to design a fully self-sufficient off grid system that would enable the household to fully cover its consumption during the entire year. The resulting analysis showed that the system would have to be significantly oversized for the consumption to be fully covered, as the uneven irradiance and therefore photovoltaic production during the year makes this endeavour very costly. Alternatively, this approach could be substituted with several different options, such as load shedding implementation or a backup generator system, while still remaining an off-grid system variant. Unfortunately, even those alternatives proved to be insufficient, resulting in the abandonment of the off-grid system variant and further consideration of a hybrid one.

The hybrid system approach has its own advantages and disadvantages, with the main advantage being its connection to the grid, to help and cover the consumption during periods of low PV generation. This is reflected in the form of several possible tariffs to take advantage of, such as a virtual battery or surplus selling. After the introduction to phenomena, specific to hybrid PV systems, the individual variants are presented with detailed system and economic analyses.

The first proposed system is aimed at minimizing its acquisition costs. Its design is combined with the usage of previously mentioned virtual battery tariff, in order to utilize the surplus generated energy through the year. The result of simulations and the analysis shows a relatively affordable PV system, with very limited return on investment, due to no actual feed-in payout, combined with higher base prices caused by the virtual battery tariff.

The second proposed system is meant as a balance between low initial investment and high performance. It involves larger module installation combined with a battery of more adequate capacity. This combination allows for significantly more consumption coverage by the PV system, while also generating a large amount of surplus, which is, in this case, sold at energy market prices. The investment return

of this variant is far more promising than that of the low investment variant, with complete investment return during its seventh year of operation and subsequent positive numbers. When compared with the current state of the household and its electricity prices, the return on investment can be observed as soon as during fourth year of operation.

The last hybrid iteration focuses on designing the system in such way that it could still be considered a micro-source under 10 kWp of installed power and therefore not requiring a licence. The larger amount of required components, together with larger battery unit and more PV modules, increase the required initial investment amount significantly, when compared to the previous two variants. However, the estimated increase in return on such investment is in no way insignificant. The system is estimated to be able to pay for itself as soon as during the sixth year of operation, with significant positive growth of investment thereafter. If compared to the control element of no PV system, this variant promises around 300 000 CZK positive difference after 10 years of operation.

The conclusion of this thesis lies in the form of a multi-criteria analysis, with the usage of criteria and factors, important to the family house owners. The result of this analysis shows the third proposed hybrid variant as the most favourable option, with corresponding share of 47.6% out of 100%. The remaining two variants were valued at 32.7% (for the second system variant) and 19.7% (for the first system variant) respectively.

13 Rozšířený český abstrakt

Cílem této práce je představení fotovoltaického fenoménu a následná realizace fotovoltaického systému s bateriovým uložištěm pro běžnou domácnost. Tyto cíle jsou rozděleny do specifických kapitol a částí práce.

V první části práce jsou čtenářům představeny základní principy fotovoltaické technologie, jako fotovoltaický jev a různé typy složení fotovoltaických modulů. Tyto vědomosti jsou poté rozšířeny teoretickým přehledem základních komponentů, které tvoří fotovoltaický systém v jeho ostrovní i hybridní podobě, pro pozdější referenci. Zároveň jsou představeny rozdíly mezi typy těchto komponentů a také jevy s nimi spojené, jako například efekty stínění na fungování fotovoltaického systému.

Následující praktická část práce je zahájena přehledem nashromážděných dat, potřebných pro pozdější design fotovoltaického systému. Objekt, který byl vybrán k provedení návrhu, je rodinný dům, s přídatnými objekty, v němž bydlí dvojčlenná rodina. Pro tuto domácnost byla poté určena spotřeba, skrze analýzu dat o roční spotřebě elektřiny, sahajících zpět do roku 2017. Rovněž je analyzován vývoj cen elektřin ymomentálního dodavatele elektřiny pro tuto domácnost, kterým je ČEZ. Tyto číselné analýzy následuje několik dalších lokálních analýz, jako například klimatické podmínky v místě navrhované instalace. Pro další potřeby návrhu jsou nejprve důkladně analyzovány všechny dostupné střešní plochy, které umožňují umístění fotovoltaických modulů, a dochází tak k vyhodnocení ploch s co možná nejvíce optimálními podmínkami, mezi které patří například sklon střechy, její rozloha a také faktor stínění během celého roku. Za tímto, ale i jinými účely jsou během práce prováděny detailní simulace v softwaru PV*SOL, který je přímo určen ke kompletní asistenci s návrhem fotovoltaických realizací. Také je v této části vyhrazen prostor pro rozbor potřebných bezpečnostních prvků, potřebných pro realizaci systému.

První návrhová část se zabývá návrhem ostrovní verze fotovoltaického systému, s požadavkem na plné pokrytí spotřeby domácnosti během celého roku. Takovýto návrh je sice finančně i realizačně velmi náročný, slouží však jako dobrý základ pro stanovení jistých faktorů a jako představení do přesnější podoby navrhování fotovoltaického systému. Pro tento návrh byly dvě plochy s nejvíce ideálními parametry pokryty vybraným typem fotovoltaických modulů, což se však se standardním provedením přídatného bateriového systému ukázalo jako nedostatečné řešení, neschopno pokrýt celoroční požadavky spotřeby. Hlavním problémem takovéto realizace, která nemá možnost dopňovat spotřebu ze sítě, jsou převážně zimní měsíce s velmi malou průměrnou intenzitou slunečního záření během dne. Kvůli tomuto fenoménu je nutno plně soběstačné ostrovní systémy, za běžných podmínek, doplnit značně nadrozměrným bateriovým systémem, který v kombinaci s panely dokáže

zajistit plné pokrytí spotřební křivky během celého roku. Finální číselné údaje takového řešení jsou však pro průměrnou domácnost značně nepraktické. Z tohoto důvodu je předneseno několik alternativ ostrovních systémů, představujících využití přídatných metodik, jako vypínání zátěží, či záložní generátor. Nejslibnější variantou ostrovního systému se pak ukázalo řešení právě se záložním generátorem, který dokázal pokrýt požadavky spotřeby během problematických zimních měsíců. Po detailnější finanční analýze systému a současné ekonomické situace fosilních paliv, se však i tato varianta ukázala jako značně nevýhodná.

Druhá návrhová část práce se zabývá tematikou návrhu hybridního fotovoltaického systému, který doplňuje nedostatky ostrovního systému možností čerpání ze sítě a za určitých podmínek také umožňuje prodej nadbytečné elektřiny v době, kdy je výroba dostatečná. Za tímto účelem je představen dotační program Nová Zelená Úsporám, který v roce 2021 prošel revitalizací, a umožňuje tak při realizaci fotovoltaického systému, za dodržení předepsaných podmínek, obdržení dotaci pokrývající až 60% pořizovacích nákladů, ve výši až 225 000 Kč. Po analýze faktorů hybridního systému následuje teoretická část jeho návrhu, jejímž cílem je identifikace optimálního designu pro takovéto řešení. Jedná se zejména o určení produkce při různých kombinacích počtu fotovoltaických modulů a velikosti baterie, s pokročilou analýzou toků energie v takovýchto systémech během celého roku. Je zde řešena také otázka případných přetoků a prodeje nezužitkované elektřiny, s několika možnostmi řešení, jako například podpůrný program virtuální baterie od skupiny ČEZ, nebo alternativní prodej za spotové ceny, udávané Operátorem Trhu s Elektřinou. Jelikož se hybridní provedení v kombinaci s některou z těchto možností využití nadbytečné elektřiny jeví jako slibná varianta řešení pro vybranou domácnost, je finální část návrhu věnována právě několika variantám tohoto typu fotovoltaického systému.

Před samotným rozбором jednotlivých variant finálního systému, je rovněž rozvedena podrobnější analýza trhu s dostupnými komponenty, potřebnými pro kompletní a fungování fotovoltaického systému, pro použití v ekonomických částech jednotlivých návrhů. Jakožto kontrolní element pro porovnání jednotlivých systémů, je realizován také výpočet ročních výdajů za elektřinu, pod současným dodavatelem domácnosti. Poté následuje rozbor jednotlivých finálních systémů, které jsou navrhovány dle specifických kritérií.

První navrhovaný systém je zaměřen na minimalizaci pořizovací ceny a jako řešení nadbytečné elektřiny využívá program virtuální baterie skupiny ČEZ. Tato varianta sice slibuje relativně opravdu dostupný systém, který je schopen díky virtuální baterii pokrýt zimní spotřebu pouze za cenu distribuce elektřiny, avšak reálná návratnost této investice není, zejména kvůli zvýšeným cenám tarifu a přidaným poplatkům za službu virtuální baterie, dostatečně rychlá. Tato skutečnost je navíc dále komplikována v případě nutnosti pořízení nových baterií a střídače po uplynutí

jejich záruční doby. Je však nutno podotknout, že i přes tyto skutečnosti systém slibuje relativní návratnost v porovnání s kontrolním elementem.

Druhý navrhovaný systém je zaměřen na vyvážený stav mezi nízkými pořizovacími náklady a vysokým výkonem. Jedná se o instalaci patnácti panelů, které pokrývají téměř celou jednu střešní plochu. Instalace o nominálním výkonu 6,75 kWp je pak doplněna baterií o velikosti 9.2 kWh, a právě tato kombinace umožňuje většinové pokrytí spotřeby s minimálními dodávkami ze sítě během roku. Rovněž dovoluje prodej značně velké sumy nadbytečné elektřiny, tentokrát u společnosti bez-Dodavatele s využitím jejich tarifu spotových cen. Návratnost této varianty je již slibnější, zejména díky prodeji za spotové ceny a vyššímu pokrytí spotřeby. Systém slibuje čistou návratnost investic během sedmého roku operace a relativní návratnost, při porovnání s kontrolním elementem, je vyčíslena již na čtvrtý rok, s pouze kladnými čísly od tohoto časového bodu dále.

Třetí, a poslední varianta se zaměřuje na maximalizaci systému tak, aby byl ještě brán jako mikrozdroj bez potřeby licence, a tak jsou v tomto případě pokryty rovnou dvě střešní plochy. Finální velikost tohoto systému je pak 9.45 kWp po stránce panelů a 11.6 kWh baterií. S touto sestavou doplněnou o patřičný střídač a ostatní potřebné komponenty, se sice dostáváme do poněkud vyšších úrovní pořizovací ceny, avšak díky velkému množství generované energie a prodeji přebytků je čistá návratnost této investice odhadována již na šestý rok se slibným růstem výdělku i poté. V porovnání s kontrolním elementem je tato varianta po deseti letech fungování okolo 300 000 Kč v kladných číslech.

Vyhodnocení nejhodnější varianty systému je poté provedeno skrze multikriteriální analýzu, za použití několika kritérií, kterým jsou, dle požadavků obyvatel domácnosti, přiřazeny různé váhy. Výsledkem této analýzy je upřednostnění třetí varianty navrhovaného systému, která požadavkům odpovídá nejvíce a to 47,6% z celku. Zbylé varianty získaly ohodnocení 32,7% pro druhou variantu a 19,7% pro variantu první. Závěrem je tedy právě toto vyhodnocení a podpora třetího navrhovaného systému jako nejadekvátnějšího vzhledem k daným podmínkám a požadavkům.

Bibliography

- [1] WOODHOUSE, M., REBECCA, J., FELDMAN D., FU, R., HOROWITZ, K., CHUNG, D., DIRK J., KURTZ, S., 2016. *On the Path to SunShot: The Role of Advancements in Solar Photovoltaic Efficiency, Reliability, and Costs*. Golden, CO: National Renewable Energy Laboratory. NREL/TP-6A20-65872. [cit. 22. 3. 2021]. Retrieved from: <https://www.nrel.gov/docs/fy16osti/65872.pdf>
- [2] BRITANNICA, *The Editors of Encyclopaedia*. "Silicon". *Encyclopedia Britannica*. [cit. 18 Feb. 2021]. Retrieved from: <https://www.britannica.com/science/silicon>
- [3] ALKHALIDI, A., A., T., AL DULAIMI, N., H., *Design of an Off-Grid Pv System for a Rural Shelter, PhD Thesis, German Jordanian university, 2017*. [cit. 2. 5. 2021]. Retrieved from: https://www.researchgate.net/publication/322738988_Design_of_an_Off-Grid_Solar_PV_System_for_a_Rural_Shelter#fullTextFileContent
- [4] SUGIANTO, S., *Comparative Analysis of Solar Cell Efficiency between Monocrystalline and Polycrystalline, INTEK Jurnal Penelitian 2020, Volume 7(2), pg.: 92-100*. [28. 4. 2021]. Retrieved from: https://www.researchgate.net/publication/347350127_Comparative_Analysis_of_Solar_Cell_Efficiency_between_Monocrystalline_and_Polycrystalline
- [5] EDOFF, M., *Thin Film Solar Cells: Research in an Industrial Perspective, AMIBO 2012, supplement 2, pg 114*. [cit. 28. 4. 2021]. Retrieved from: https://www.researchgate.net/publication/230610770_Thin_Film_Solar_Cells_Research_in_an_Industrial_Perspective
- [6] VELILLA, E., RESTREPO, S., JARAMILLO, F., *Cluster analysis of commercial photovoltaic modules based on the electrical performance at standard test conditions, Solar Energy, Volume 144, 2017, Pages 335-341, ISSN 0038-092X* [cit. 12. 2. 2022]. Retrieved from: <https://www.sciencedirect.com/science/article/pii/S0038092X17300579>

- [7] DOLARA, A., LAZAROIU, C. G., LEVA, S., MANZOLINI, G., *Experimental investigation of partial shading scenarios on PV (photovoltaic) modules*, *Energy*, Vol 55, pg. 466/475, Department of Energy, Politecnico di Milano, Via Lambruschini 4, 20156 Milan, Italy, 2013, ISSN 0360-5442. [cit. 2. 5. 2021]. Retrieved from: https://www.sciencedirect.com/science/article/abs/pii/S0360544213003095?casa_token=_paV5S28FIAAAAAA:rKW2GTUETKYIvs6sXAAM1XIFa7oaEjYUMBK4AdZd68I4h3AahBJIaGNEQCUS50k60eDY3lrfra
- [8] MANOJ, K., P., Dr. NAREJO, G., B., *Effects of Humidity on the Efficiency of Solar Cell (photovoltaic)*, Department of Electronic Engineering, NEDUET, Pakistan. *International Journal of Engineering Research and General Science* Volume 2, Issue 4, June-July, 2014 [cit. 2. 5. 2021]. Retrieved from: <http://ijergs.org.managewebsiteportal.com/files/documents/EFFECT-61.pdf>
- [9] YANG, B., ZHU, T., WANG, J., SHU, H., YU, T., ZHANG, X., YAO, W., SUN, L., *Comprehensive overview of maximum power point tracking algorithms of PV systems under partial shading condition*, *Journal of Cleaner Production*, Volume 268, 2020, 121983, ISSN 0959-6526 [cit. 12. 2. 2022]. Retrieved from: <https://www.sciencedirect.com/science/article/pii/S0959652620320308>
- [10] CHEN, S., LI, P., BRADY, D., LEHMAN, B., *Determining the optimum grid-connected photovoltaic inverter size*, *Solar Energy*, Vol. 87, 2013, Pages 96-116, ISSN 0038-092X [cit. 7. 5. 2022]. Retrieved from: <https://www.sciencedirect.com/science/article/pii/S0038092X12003362>
- [11] CEZ GROUP, *Price list archive, 2022* [cit. 8. 4. 2022]. Retrieved from: <https://www.cez.cz/cs/podpora/ceniky.html>
- [12] Czech Republic, *Decree No. 16/2016 Sb., on the conditions of connecting to the electrical power system, Wording from 1. 1. 2022* [cit. 23. 4. 2022]. Retrieved from: <https://www.eru.cz/vyhlaska-c-16-2016-sb-o-podminkach-pripojeni-k-elektrizacni-soustave?inheritRedirect=true>
- [13] Czech Republic, *Act No. 458/2000 Sb., The Energy Act, Wording from 1. 2. 2022* [cit. 23. 4. 2022]. Retrieved from: <http://www.mvcr.cz/soubor/sb095-09-pdf.aspx>
- [14] Czech Republic, *Act No. 165/2012 Sb., The act on supported energy sources and on amendment to some laws, Wording from 1. 1. 2022* [cit. 24. 4. 2022]. Retrieved from: <http://aplikace.mvcr.cz/sbirka-zakonu/ViewFile.aspx?type=z&id=24254>

- [15] *Energy Regulatory Office, Energetický regulační věstník 8/2021, 2021.* [cit. 3. 5. 2022]. Retrieved from: <https://www.eru.cz/energeticky-regulacni-vestnik-8-2021>
- [16] *The European Commission's science and knowledge service, Photovoltaic Geographical Information System (PVGIS), 2021.* [cit. 22. 9. 2021]. Retrieved from: https://re.jrc.ec.europa.eu/pvg_tools/en/#
- [17] *DHIMISH, M., SILVESTRE, S., Estimating the impact of azimuth-angle variations on photovoltaic annual energy production, Clean Energy, Volume 3, Issue 1, March 2019, Pages 47–58*
- [18] *KOŠŤÁL, J. (TRANSLATOR), Bezpečné odpojení fotovoltaických zařízení, ELEKTRO, 2011, 04/2011* [cit. 8. 5. 2022] Retrieved from: <http://www.odbornecasopisy.cz/elektro/casopis/tema/bezpecne-odpojzeni-fotovoltackych-zarizeni--9837>
- [19] *Saltek, s. r. o., Přepěťové ochrany pro fotovoltaické systémy – zapojování, značení, ELEKTRO, 2011, 04/2011* [cit. 8. 5. 2022] Retrieved from: <http://www.odbornecasopisy.cz/elektro/casopis/tema/prepetove-ochrany-pro-fotovoltacke-systemy-zapojovani-znaceni--9842>
- [20] *ČEZ Distribuce, a. s., Připojovací podmínky pro výrobní elektrárny, pro připojení k distribuční soustavě ČEZ Distribuce, a. s., Valid since 1. 8. 2020* [cit. 8. 5. 2022] Retrieved from: <https://www.cezdistribuce.cz/webpublic/file/edee/distribuce/pripojovacipodminkyvyrobnny.pdf>
- [21] *Státní fond životního prostředí ČR, Závazné pokyny pro žadatele a příjemce podpory programu Nová zelená úsporám v rámci Národního plánu obnovy - RODINNÉ DOMY, 2021. Section C.3, pg. 17-19.* Retrieved from: <https://novazelenausporam.cz/dokumenty/rodinne-domy/>
- [22] *Czech Statistical Office, Average prices survey of selected products - fuels and oil products - time series* [cit. 8. 3. 2022]. Retrieved from: <https://www.czso.cz/csu/czso/average-prices-survey-of-selected-products-fuels-and-oil-products-time-series>
- [23] *Beltran H, Ayuso P, Pérez E (2020) Lifetime expectancy of Li-Ionbatteries used for residential solar storage. Energies 13(3):568.* [cit. 9. 3. 2022]. Retrieved from: <https://www.mdpi.com/1996-1073/13/3/568/htm>

- [24] *CEZ GROUP, Výkup Elektriny v Tržním Režimu, Ceník, 2022* [cit. 20. 4. 2022]. Retrieved from: <https://www.cez.cz/edee/content/file/produkty-a-sluzby/obcane-a-domacnosti/elektrina-2021/mop/20210419-vykup-elektriny-v-trznim-rezimu-mop.pdf>
- [25] *OTE, a. s., Statistics - Yearly reports, 2017-2022* [cit. 20. 4. 2022]. Retrieved from: https://www.ote-cr.cz/en/statistics/yearly-market-report?set_language=en&date=2022-01-01
- [26] *European Central Bank, Euro foreign exchange reference rates (CZK), 2017-2022* [cit. 20. 4. 2022]. Retrieved from: https://www.ecb.europa.eu/stats/policy_and_exchange_rates/euro_reference_exchange_rates/html/eurofxref-graph-czk.en.html
- [27] *CEZ GROUP, Elektrina pro Soláry, 2022* [cit. 25. 4. 2022]. Retrieved from: https://www.cez.cz/edee/content/file/produkty-a-sluzby/obcane-a-domacnosti/elektrina-2022/moo/cez_cenik_elektrina_pro-solary_na_3_roky_moo_2022_04_cezdi_web.pdf
- [28] *bezDodavatele a.s., Vaše energie - Podmínky výkupu přebytků elektriny vyrobené fotovoltaickou elektrárnou pro domácnost, 2020* [cit. 27. 4. 2022]. Retrieved from: https://www.bezdodavatele.cz/wp-content/uploads/2020/08/bD_Vykup_Podminky_BD-SD-SV-DE_20200814-01.pdf
- [29] *OTE, a. s., Short term markets, 2022* [cit. 27. 4. 2022]. Retrieved from: https://www.ote-cr.cz/en/short-term-markets/electricity/day-ahead-market?date=2022-01-25&set_language=en
- [30] *Fronius International GmbH, Fronius warranties, online* [cit. 16. 5. 2022]. Retrieved from: <https://www.fronius.com/en-au/australia/solar-energy/installers-partners/service-support/warranty-models>
- [31] *Solax Power Network Technology(Zhe jiang) Co., Ltd, Triple Power Lithium-ion Battery - User Manual, online* [cit. 16. 5. 2022]. Retrieved from: https://gbc-solino.cz/wp-content/uploads/2021/12/MNL_SOLAX_TRIPLE_POWER_T30-EN-1.pdf
- [32] *GROWATT NEW ENERGY TECHNOLOGY Co.,LTD, Growatt 3000TL3-S/4000TL3-S/ 5000TL3-S/6000TL3-S - datasheet, online* [cit. 16. 5. 2022]. Retrieved from: <https://pro-solar.com.au/documents/growatt-3p-3kw-to-6kw-inverter.pdf>

- [33] *Solax Power Network Technology(Zhe jiang) Co., Ltd, Triple Power - datasheet, online* [cit. 16. 5. 2022]. Retrieved from: <https://www.solaxpower.com/wp-content/uploads/2022/03/T-BAT-SYS-HV-5.8T58-V2.0.pdf>
- [34] *GROWATT NEW ENERGY TECHNOLOGY Co.,LTD, Growatt 7000TL3-S/8000TL3-S/9000TL3-S/10000TL3-S/11000TL3-S - datasheet, online* [cit. 16. 5. 2022]. Retrieved from: <https://download.solarclarity.nl/2018/06/Growatt-7000-11000TL3-S-Datasheet-1.pdf>
- [35] *Saaty, R.,W., The analytic hierarchy process—what it is and how it is used, Mathematical Modelling, Volume 9, Issues 3–5, 1987, Pages 161-176, ISSN 0270-0255* [cit. 16. 5. 2022]. Retrieved from: <https://www.sciencedirect.com/science/article/pii/0270025587904738>
- [36] **Available market prices, 2022**

The following list contains all of the various online vendors used for price references and market evaluation through the thesis. When referencing prices of components or their average price values, they were drawn from one or more of the following vendors. This is mainly done to attempt and avoid situations of vastly different prices for the same components or parts of the systems.

- ABCtech s.r.o. - <https://www.abctech.cz/default.asp>
- ARGOS ELEKTRO, a.s. - <https://argos.cz/>
- Atos spol. s.r.o - <https://shop.atoselektro.cz/>
- BUTTERFLY VISION s.r.o. - <https://www.solarsun.cz/>
- CeníkŘemesel.cz - <https://www.cenikremesel.cz/>
- CUP Security s.r.o. - <https://cup-elektro.cz/>
- DEK a.s. - <https://www.dek.cz/>
- Donoci s.r.o. - <https://www.svet-svitidel.cz/>
- DŮM, PARKY A ZAHRADY s.r.o. - <https://e-elektromaterial.cz/>
- EBORX Sp. z o.o. - <https://pvshop.eu/>
- ECO PRODUKT s. r. o. - <https://ecoprodukt.cz/>
- eibmarkt.com GmbH - <https://www.eibabo.cz/>

- Elektro Fiala s.r.o. - <https://www.elektrofiala.cz/>
- Elektro Malínský - <https://www.elektro-malinsky.cz/>
- Elektro Mika s.r.o. - <https://www.elektromika.cz/>
- ELEKTRO S.M.S., spol. s r.o. - <https://shop.elektrosms.cz/>
- Elektro-Sychra, spol. s r.o. - <https://shop.elektro-sychra.cz/>
- ELHURT PLUS - <https://aququ.cz/>
- ELIMA ELEKTRO S.R.O. - <https://www.elima.cz/obchod/index.php>

- Europe-SolarStore.com - <https://www.europe-solarstore.com/>
- EWD ELSTROEM s.r.o. - <https://www.elektrotechmat.cz/>
- Extreme Solar - <https://www.extremesolar.hu/>
- FVE-MP s.r.o. - <https://www.fve-mp.cz/>
- Green Energy Trading s.r.o. - <https://www.gettrading.eu/>
- HARKO s.r.o. - <https://www.koupelnyatopeni.cz/>
- iElektra s.r.o. - <https://www.ielektra.cz/>
- Iftech - <https://shop.iftech.cz/>
- K&V ELEKTRO a.s. - <https://www.kvelektro.cz/>
- Krel Central a.s. - <https://www.elektrocentraly.cz/>
- Levný-elektromateriál.cz - <https://www.elektromaterial.cz/>
- LU-MI servis s. r. o. - <https://www.akunadrze.cz/>
- mivvy a.s. - <https://www.mivvyenergy.cz/cs/>
- NBB Bohemia s.r.o. - <https://eshop.nbb.cz/led-technologie>
- Neosolar, spol. s r.o. - <https://eshop.neosolar.cz/>
- Optimus A-Trade s.r.o. - <https://www.eshopelektronika.cz/>
- PCsupport.cz s.r.o. - <https://www.ledveci.cz/>
- PEN CZ s.r.o. - <https://www.elektropen.cz/>

- Permasynergy - <http://www.permasynergy.cz/>
- PVGroup.pl - <https://pvgroup.pl/>
- RD Solar s.r.o. - <https://www.rdsolar.cz/>
- Renugen Limited. - <https://www.renugen.co.uk/>
- Resacs - <https://www.resacs.cz/>
- Solar Bouwmarkt - <https://www.solar-bouwmarkt.nl/>
- SolarPartner s.r.o. - <https://shop.solarpartner.cz/>
- Solartec MED s.r.o. - <https://shop.solartec.eu/>
- Stralendgroen - <https://www.stralendgroen.nl/>
- SUN PI S.R.O. - <https://www.obchodsolar.cz/>
- SunTechnology - <https://shop.suninhouse.eu/gb/>
- SVĚTSoučástek.cz - <https://www.svetsoucastek.cz/>
- SVP Solar s.r.o. - <https://www.solar-eshop.cz/>
- SVX s.r.o. - <https://www.svx.cz/>
- TME Czech Republic, s.r.o. - <https://www.tme.eu/cz/>
- Volux.cz - <https://www.volux.cz/>
- VS ELEKTRO PLUS s.r.o. - <https://www.vselektro.eu/>

Symbols and abbreviations

AC	Alternating current
CZK	Czech Koruna
DC	Direct current
EfS	Energy for Solar - a ČEZ program
EUR	The euro
MPPT	Maximum power point tracking
NGSP 2021	New Green for Savings Program 2021
kWp	kilowatt-peak - nominal power
OTE	Czech electricity and gas market operator
PV	Photovoltaic
SoC	State of Charge
STC	Standart test conditions