



Seeking solutions for Displaced Peoples: Portable Off-grid Washing Facility (POWF)

Thesis Project
CULS 2018
Prague, Czech Republic

Albert Kenton Muhleman, III
April 21, 2018



© Albert K. Muhleman

Abstract

The aim of the thesis: to create the most portable, reusable, environmentally-sound method for cleaning clothing and bedding in the chaotic, unsanitary conditions of the 21st-century refugee/displaced peoples camps proliferating around the globe. The creation of the building is inclusive, socially sensitive and pragmatic, as its continued operation. This project utilizes off-the-shelf and cutting-edge technologies side-by-side. Its aim is to ameliorate the sanitary conditions in an attempt to restore dignity..

Utilising a fusion of current technologies: solar energy, solar water heating, vastly-improved battery technology, engineered bamboo, with modern greywater applications that fertilize banana trees groves planted in circles around shallow pits not far from the washing machines the POWF becomes a physical, and psychological oasis.

The thesis project creates an enzymatic effect that cleanliness can have in the modern disaster relief camp. The aim of this thesis project is to ameliorate the dire situation of the modern displaced person/refugee in permanent effective and empowering way by restoring their basic human dignity with simple sanitation under challenging circumstances.

Table of Contents

<u>Chapter Number</u>		<u>Page number</u>
1.0 Introduction		1
1.1 Types of disasters		1
2.0 Literature Review Introduction		2
3.0 Types of camp inhabitants		3
4.0 Settlement options open to displaced populations		4
5.0 Camp Layout		4
5.1 Social and Environmental Implications		4
5.2 Security		5
6.0 Types of Shelters		5
6.1 Emergency shelter		6
6.2 Temporary Shelter		6
6.3 Temporary Housing		6
6.4 Transitional Shelters		6
6.5 Progressive Shelters		6
6.6 Permanent Housing		6
7.0 Cultural Sensitivity		7
8.0 Housing Solutions		7
8.1 Military Criteria		8
8.2 Construction Classification		8
8.2.1 Standard Construction with New Materials		8
8.2.2 New Construction with New Materials		8

8.23 Alternate Systems,		
8.3 Prefabrication Solutions		8
9.0 Logistics of Reconstruction		8
10.0 "Build Back Better" Precepts		8
11.0 Disaster Mitigation-Strategic		9
Environmental Assessment and		10
Environmental Impact Assessment		
(SEA/EIA)		
12.0 Conclusion of Literary Review		
13. The Camp Layout		12
13.1 Debris		13
13.2 Hygiene		13
13.3 Location Permanence		13
14.0 Water in the Camps		15
15.0 Sanitation in the Camps		15
16.0 Bamboo		15
16.1 Bamboo Characteristics		15
16.2 Building with Bamboo		15
16.4 Tensile Strength & Compression		16
Strength		16
16.5 Disadvantages of Bamboo		
17.1 Vo Trong Nghia Method of		16
Vietnamese Engineered Bamboo		17
preparation		
17.2 CLC Thai Method Engineered		

Bamboo preparation		17
17.3 Borate Treatment		
18. Application (Methodology): Portable		18
Off-grid Washing Facility (POWF)		18
18.1 Solar Panels Electricity Calculations		
in POWF		19
18.2 Washing Machines		
18.3 Eye-Catching Structure		20
18.4 Bamboo Struts		20
18.5 High-tech and low-tech Mix		20
18.6 Outer covering UNHCR Canvas		21
18.7 Water Management		21
18.8 Greywater Treatment		22
18.9 Complies with UNHRC Sanitation		23
Standards		23
18.10 Hygiene Consideration		23
18.11 The Structure		23
18.12 Prefabrication/ Advantages of		24
Modular Construction		25
19.0 Bamboo Strut Joins		
20.0 Tesla Powerwall 2 Battery		25
21.0 Results		25
		26
		26
21.1 CHART OF MATERIALS		27

22.0 Discussion		28
23.0 Conclusion		30

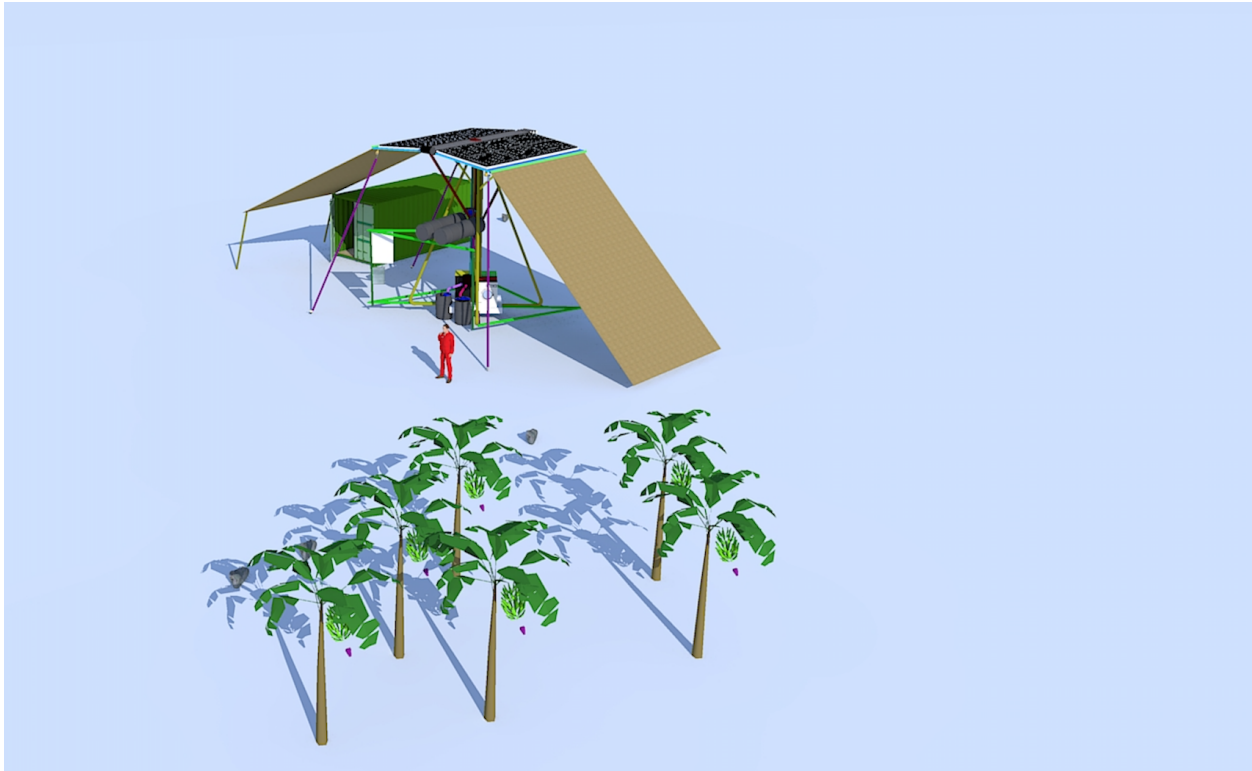

© Albert K. Muhleman

Seeking solutions for Displaced Peoples Portable Off-grid Washing Facility (POWF)

Transformative, fundamental change happens in those rare moments when social movements or social actors are able to work effectively across each of the dimensions simultaneously, when they are able to link the demands for opening previously closed spaces with people's action in their own spaces; to span across local and global action, and to challenge visible, hidden, and invisible power simultaneously... Successful change is about getting each of the pieces on each dimension of the cube to align with each other simultaneously. -John Gaventa

It is sobering to be reminded that one of the basic instincts of human nature, mutual cooperation for no cost, is thriving on a global scale. -Evert Bopp

1.0 Introduction

Political instability and natural disasters create large numbers of dislocated people. Their needs are urgent and encompass life-threatening situations. Sanitation, safe drinking water, health services, shelter, food supply, and personal security are paramount to recovery and rebuilding, all in the immediate time frame (Fenner, Guthrie, Piano 2007). According to the Centre for Research on the Epidemiology of Disasters (CREDE 2018)'s International Disaster Database, there were 220 disasters per year in the mid-1990's, which has since increased to 350-400 per year costing \$200 billion. The Emergency Events Database (EM-DAT) indicates that between 1994-2013: 218 million people were affected by natural disasters each year; a total of 6,873 disasters, equaling 1.35 million lives affected with an average of almost 68,000 deaths per year (Wallemacq and Below 2015).

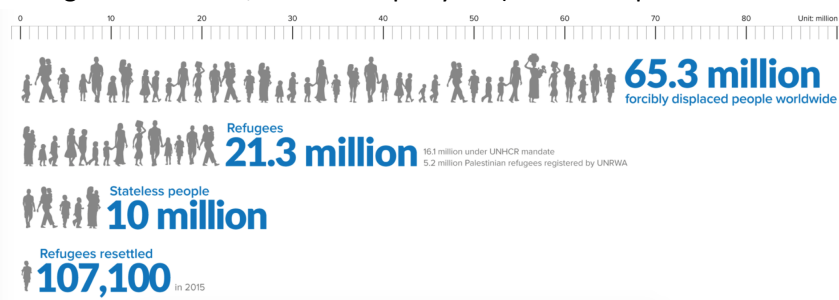

(Figure 1) © UNHCR

1.1 Types of disasters

Common types of disaster are public anarchy, industrial accidents, oil spills, communication failures, acts of terrorism, industrial sabotages, fires, and, natural disasters, such as tsunamis, earthquakes, typhoons, mudslides, hurricanes, and avalanches.

Life becomes a primal exercise in survival. Essential social, material, and cultural needs claw from the rubble. The effects of a disaster are multi-pronged: infrastructure, utilities, power lines, roads, bridges, canals, railroads are compromised, or destroyed. All economic activity is thrown into disarray. Hindered food production and uneven distribution result in shortages that affect the wellbeing of the affected population.

Often governments are caught unprepared, lacking the will, the interest, or the ability, to respond effectively to the situation. Political actors. Medical care is imperative yet challenged, as large numbers of people are injured. Widespread destruction of infrastructure and of dwellings exacerbate these problems (Noji 1996). The entire profile of a society is compromised.

Housing is the people's main priority. Extrapolating on Abraham Maslow's "Hierarchy of Needs," the concept of "shelter," would exist between the first and the second tiers in Deficiency Needs levels. Providing warmth, rest, security, and safety; effective housing can be the pathway to social actualization by helping the displaced adjust to the chaos and move up the hierarchy to achieve stability. The lack of this most basic human necessity and the need to fix the problem inflict duress on the population.

Over 17 million people worldwide currently lack a roof over their heads. It destabilizes entire societies (Song, Mithraratne, Zhang 2016)/(Ahmed 2011). Problems that exist in creating effective shelter result from having no stockpile of housing, or even its basic components; a short-sightedness towards the complexities of the existing conflicts and the tug-of-wars that exist in every community, constricted by self-imposed, rigid bureaucracies within relief groups, and governments alike; inadequate communications with the stakeholders and finally sloppy handling of the limited resources that remain (Quarantelli 1995). Post-disaster, the urgency of sheltering displaced people is increased due to the severity of mental, physical, and spiritual stress they are undergoing. Their very "dignity, identity, and privacy," are compromised (Félix, Branco, Feio 2013). In the ensuing tumult, "scenarios have all the factors to produce inadequate solutions, mainly due to the need for a rapid and large-scale action under chaotic conditions" (Davidson, Lizarralde, Johnson 2008). The need to get people back to self-sufficiency intensifies the urgency of the reconstruction (Félix, Branco, Feio 2013). Tragically, the very susceptibility of the world's poor increases their vulnerability to natural disaster. Their exposure continues afterwards, when the re-development is not handled well (Schilderman 2004).

According to the Royal Institution of Chartered Surveyors (2006) disaster relief can be divided into three steps: Emergency Response, Relief-Recovery-Reconstruction, and Mitigation-Preparedness (Karunasena and Rameezdeen 2010). Recently perceptions of disaster have changed. Hazards are intrinsic to many human settlements and failure to factor them into the fabric of social management has been a grave error on the part of governments worldwide. They test the community's flexibility on many levels, and ultimately, its very existence (Oliver-Smith 1996). Disasters have only recently been introduced to policy-making decisions (Tierney 2007). Although the earliest modern rumblings of a coalescing broader social conscious in responding to natural disasters are well illustrated by Rousseau and Voltaire's dialogue about the 1755 Lisbon earthquake.

Poorly-thought-out development in ecologically-inappropriate locations, haphazard and short-sighted construction, and the graft that often accompany it, over-reliance on quick-fix technologies, over-manipulation of the land at cross-purpose with nature, and the inevitable social relegation of the poor to the lowest quality areas, all create a scenario guaranteeing subsequent disasters resulting from the initial catastrophe (Tierney 2007). From a social point of view, disasters need to be considered as elemental occurrences that are "episodic, foreseeable manifestations of the broader forces that shape societies (Tierney 2007)." In pure economic terms, the entities that insure against disaster are most alarmed and exposed by the losses of property, as they are the most widespread and expensive. Disasters have the uncanny ability to strike the most defenseless populations the hardest (Tierney 2007).

Early research in the field of disaster positioned itself to examine "organizational and collective behavior under high-stress conditions (Tierney 2007)." Disaster relief must develop a more forward-thinking approach that considers creative methods to rebuild durable communities, strengthened from their reconstruction and bolstered to withstand such events in the future (Anh, Phong, Mulenga 2014).

2.0 Literature Review Introduction

Disaster Relief-Disaster Relief Camps

Demand for rebuilding is as urgent as the situation is destabilized. Unfortunately, the process of reestablishing a community takes a long time (Ahmed 2011). Camps that are not well-adapted to local

affected populations morph into blight and chaos. The local environment suffers drastically. These two reasons create tension between camps and local population (Abulnour 2014).

Shelter fights disease, creates safety, and minimizes human impact on the environment (Bashawri, Garrity, Moodley 2014). Developing countries are the most vulnerable to disaster and endure the most disasters and inevitably the poor bear most of the suffering (Ahmed 2011).

Shelter after a disaster "incubates" the population by providing a crucible within which it can re-form itself. One of the earliest steps to rebuilding, providing shelter ensures that the situation stabilizes enough to begin to gauge and then, correct the destruction (Abulnour 2014). There are three main stages to Disaster Relief: preparatory, immediate, and reconstructive (Kovács and Spens 2007). Preparation and immediate stages fall within the precepts of strategic planning. When disaster strikes, hands-on, pragmatic, in-the-moment organization is essential (Kovács and Spens 2007). Unfortunately, disaster relief shelters have proven to lack durability (Arsalan and Cosgun, 2007).

Creating new dwellings after disaster is a great opportunity to rejuvenate local communities especially when it utilizes native products, skills, and labor (Abulnour 2014). In the developing world an individual's dwelling is their most prized possession, and in a disaster housing is the asset that is most often compromised. This is reflected in the fact that damage to dwellings is the largest percentage of the cost of the whole affair (Ahmed 2011). Smooth-flowing logistics, readily-available housing resources, and the money to make them run are essential. The need for shelter is immediate. It is imperative that the requisite building material is on-hand (Abulnour 2014). Housing reconstruction engenders recovery (Ahmed 2011).

The urgency of replacing the affected populations' living quarters dominates reconstruction. To be without a roof over one's head decimates one's sense of "dignity, identity, and privacy." In addition, this state of disconnectedness and exposure increases the incidence of disease and worsens the area's level of pollution (Bashawri, Garrity, Moodley 2014). Adequate shelter is defined as an "immediate environment for all aspects of family life, providing protection from the elements, secure tenure, personal safety, and access to clean water and sanitation, proximity to places of employment and educational and health care facilities." (UN/OCHA/ESB 2006) and (Hadafi, 2010).

The rebuilding of shelters must take into account the needs and realities of the affected population, making sure they are a custom fit for those exact conditions (Bashawri, Garrity, Moodley 2014). Supplies are often propelled to the disaster area in an erratic fashion due to the lack of intimate knowledge of the situation *in situ*, and the "unpredictability of demand." (Kovács and Spens 2007). "Right people, equipment and material, in the right place, in the right sequence as soon as possible, to deliver the maximum relief at the least cost equals saved lives, reduced suffering and was the best use of donated funds," HELP Forum (CILT 2006).

The three phases of Disaster Relief are Preparedness, During operations, and Post-operations (Kovács and Spens 2007). Shelter after a disaster is of paramount importance. Security and privacy are a must. Without them rehabilitation of the area cannot even begin. Immediate and short-term shelters help victims in a twofold manner, they create not only a secure space to start over but also a refuge for rejuvenation (Bashawri, Garrity, Moodley 2014).

3.0 Types of camp inhabitants

There two main kinds of people in disaster: Displaced Peoples: those who were previously inhabitants uprooted either by the vagaries of nature or man, and seek to re-establish themselves in the immediate vicinity of where they dwelt, and Refugees: those, less fortunate, who are forever swept away from their homes and lands, and are at best shunted from unsound location to unsound location, at worst pursued, to rude, semi-permanent accommodations, often at the whim of other governments, tribes, religions, who may or may not have their best interests in mind. There is a problem Refugees encounter: the building of functional, humane disaster relief camps creates a backlash from existing settled societies that often view temporary camps' very success as a red flag.

4.0 Settlement options open to displaced populations

In the disaster's aftermath there will exist numerous feasible methods of organizing and improving the conditions. For the sake of pragmatism aid organizations and authorities must underwrite a mix of settlement projects for the displaced victims. Inevitably there will be independent-minded groups who choose entirely, unthought-of options with or without their assistance. Transitional settlement options exist as the states of

- Dispersed in host families
- Dispersed in rural self-settlement
- Dispersed in urban self-settlement
- Grouped in collective centers and mass shelters
- Grouped in self-settled camps
- Grouped in planned camps (Oxfam 2005)

When the population has the luxury of choosing between several options for their work, security, and community redevelopment, their prospects for ultimate triumph over duress increase. By not focusing on the special needs of specific groups the relevant authorities can carry on their job more efficiently, freed from wearing too many hats. More energy can be directed to those in the direst need.

5.0 Camp Layout

Most victims are attached to their original area by innate and strong bonds, and most return to that area where they lived before and attempt to rebuild there, often in the exact spot (Quarantelli 1995). The necessity of shelter dictates that Disaster Relief dwellings need to be durable enough to last months-to-years. Physical location and the stakeholders' situation must be taken into account (Bashawri, Garrity, Moodley 2014). When establishing a camp many varied components of the big picture must be taken into account, the local climate: relative humidity, temperature range, wind speed; whether or not education, health facilities, and gainful employment even exist, and the distance to them; the extent to which the infrastructure is compromised, the way the camp compares to the area the way it was before the disaster; and whether the camp's placement is destined to repeat planning mistakes from before. In addition, the actual amount of allocated space between the shelters, the number of people they accommodate, the overall amenity of the arrangement needs strict accounting.

5.1 Social and Environmental Implications

As always, the economic, tribal, and educational requirements are of paramount importance (Abulnour 2014). IAP Workshop on Disaster Management Practices designates areas that are flood-

proof, drain effectively, are not prone to sinkholes, do not sit too close to the local water table, remain a safe distance from possible landslides, can be reached without duress, with larger intact population centers nearby, sit above the level of waste fields, and are downstream from potable water as the best possible localities for resettlement (Bhave, Choudhury, Pemde, Mathur 2005).

This level of site planning demands more than just physical management of the emergency situations. Landscape architectural design precepts should be adhered to in these circumstances from the start. When lives are at stake, the early steps of background study, thorough site analysis, and discerning a clear approach to the disaster zone take on a whole new urgency for functional, pragmatic, enlightened design. Then, at an accelerated pace, circulation and connectivity issues are assessed, the requisite schematic designs emerge, the design of the community can be quantified, and the most pressing financial demands of the rebuilding project crystalize. The project hones in at this point to create working drawings, incorporating the essential technical details discovered in the data collected.

It is essential to sift out the corruption in the community; so that equitable, non-rigged bidding attracts contractors capable of completing the job. Once the necessary contractual paperwork is done, the site planner retires to a role of involved observer, frequently visiting the afflicted zone to gather more data and to monitor the efforts of the contractors with vigilance, as their task is more urgent in a crisis zone, the end result is a stabilized, reinvigorated society well on its way back to normality.

5.2 Security

Building the camp layout well guarantees its future safety, security, and overall efficiency. Often the shareholders' current planning is the best approach. The best advice is: Be pragmatic and strive to reduce the community's exposure to further damage, both internal and external. Challenging as it may be, work within the local legal and ownership precepts. Create plans that give all camp entities access to the dwellings and anticipate essential services. Utilize the topography effectively.

Keep the local environment from further degradation by once again operating within the local ways of settlement. Monitor all sites for fire liability. Take measures to create enough space between structures to maintain safety. Control vector risk by choosing sites removed from debris and saturated areas. Measures must be taken to clean up the compromised state of an area, due to its creation of ideal circumstances for pests that could adversely affect local population. Involve the local shareholders in the planning of their camps by including all persons of concern, local or central government authorities, community and religious leaders, the affected community itself, NGOs, IFRC, ICRC, UN, news media (UNHCR 2015), and social media.

6.0 Types of Shelters

The demand for so much new housing so quickly is a difficult gap to fill (Song, Mithraratne, Zhang 2016). Initially, the definitions for the classification for shelter were comprised of four types:

6.1 Emergency shelter is the most immediate, the main aim being very basic life-support within a short timeframe. Only basic cooking and temporary medical services are available. This kind of shelter is utilized while the emergency is at its peak; it can be as basic as a neighbor's house, a child's treehouse, the local high school gym, or a garden shed.

6.2 Temporary Shelter can be designed for weeks at a time and can again be a public shelter, often on a larger scale like a stadium, but sometimes as primitive as a tent (IFRC/RCS 2013). With an eye

towards the brief time victims are designed to be in this kind of shelter, the focus is on how quickly and how inexpensively it can be constructed (Bashawri, Garrity, Moodley 2014).

6.3 The third type, **Temporary Housing**, involves more material and more work. It includes rental housing and prefabricated housing such as trailers. These structures are placed on temporary land and are forecast to be usable for six months to three years. Rental and prefabricated units are the ideal here, as they allow their inhabitants to return to work (Bashawri, Garrity, Moodley 2014), and in ideal situations, their components can be repurposed.

The difference between Temporary Housing and Permanent Housing is more pronounced than the difference between Emergency Shelter and Temporary Housing (Quarantelli 1995), and yet further research has created three additional classifications.

6.4 Transitional Shelters sprout up in every disaster, a direct result of human pluck and ingenuity. The displaced should be encouraged to create these (IFRC/RCS, 2013), if environmental responsibility can be observed. These are designed to last from many months to years. They acquire a permanence in the landscape and often form the kernel that becomes permanent dwellings. They can be resold or rented, their components and parts recycled, or repurposed as business locations (International Organization for Migration, 2012).

6.5 Progressive Shelters cost more, use innovative, yet untested technologies can be difficult to set-up but are consistently upgradable and designed for long-term use (IFRC/RCS, 2013). Core Shelters or One-Room Shelters can have all of advantages and disadvantages of Progressive ones and are still more expensive options. They strive to incorporate essential services, such as a foundation, plumbing, electricity, even sewage (International Organization for Migration, 2012). With these, the main objective is to construct a dwelling of up to two rooms that pass or surpass local building codes and are upgradable, although still not a "permanent" house (IFRC/RCS, 2013).

6.6 The final state of **Permanent Housing** is reached when the individuals can return to their rebuilt house, or acquire a completely new one to live in permanently (Félix, Branco, Feio 2013). These can be upgraded from Transitional Shelters, Progressive Shelters, Core Shelters/One-Room Shelters, or even a new house. The difference between Temporary Housing and Permanent Housing is more pronounced than the difference between Emergency Shelters and Temporary Housing (Quarantelli 1995).

7.0 Cultural Sensitivity

Disasters create innumerable variations because of the complexity and diversity of culture, population density, topography, weather (Bashawri, Garrity, Moodley 2014). Without the input of the affected shareholders, solutions are inherently flawed. Quick fixes are anything but. Operating on the proximate causes and not ultimate causes of disaster invites failure and can worsen already dire situations. Rigid methods do not "address the vulnerability, or make it worse." The dire specter of graft and malfeasance is exacerbated by breakdowns in cooperation with sectors and institutions, engendering unworkable, counterproductive plans (Schilderman 2004). The clash of cultures is often apparent in the donor aid (Karunasena and Rameezdeen 2010) in 1989 Loma Prieta Earthquake in Watsonville, California, Latino residents whose social and cultural needs were not being met built their own shelter to ensure aid-givers recognized their unique requirements (Tierney 2007). Remaking the

environment entails disagreements (Oliver-Smith 1996) revealing the different social strata in sometimes uncomfortable ways.

People are attached to their land in a deep psychological and spiritual way, and the dislocations caused by disasters cause them formidable psychic stress (Oliver-Smith 1996). People identify with their 'patch of earth' to such an extent that it is wound not only into their history and identity but also into how they interact with and view the outside world (Oliver-Smith 1996). Investigating the current local situation to find a consensus on the needs of the affected is essential in rebuilding their environment. It is all too easy to reconstruct in a manner both socially- and ecologically-flawed, repeating the mistakes of the past. In the construction of the architecture, utilities, and the physical locations used for temporary shelter, there exists a lack of consideration of the variations in living standards between donors and recipients (Karunasena and Rameezdeen 2010).

Engaging the community in the rebuilding process forges an enduring bond between them and their newly-built structures (Karunasena and Rameezdeen 2010). The most efficient method, the self-built house, possesses an inherent efficiency in utilizing local workers and available materials from the affected areas; whereas, donor-built housing lacks cost-effectiveness for this very reason (Schilderman 2004). Due to the urgent, unprecedented nature of the event, solutions that are dictated by outside or governmental institutions tend to ignore the needs and wants of the affected people.

Conversely, planning and management techniques that engage the affected population in the decision-making process succeed because they address the realities of the local culture, economy, and ecology, and the people are empowered (Karunasena and Rameezdeen 2010). When the ruin is widespread and severe the reconstruction process morphs into long-term development programs and the disaster relief camp establishes a precarious permanence in the society (Oliver-Smith 1996).

8.0 Housing Solutions

Using the **Military Value Parameters/Complexity Scale** prospective housing can be deemed: **Excellent**, if the various pieces can be assembled with less than an hour of training with no previous construction skills and need no uncommon tools.

Good, if after 1-4 hours training stakeholders can complete the build using minimal construction ability and basic electrical tools. This entails at least one basic carpenter per build is part of the construction crew.

Fair, 5-8 hours to complete using specialized tools such as large electric drills, pneumatic tools, and medium construction skills. In this case, people with competent skills in carpentry and flat masonry work are required in each build.

Poor, 8 hours-plus instruction, specialized tools, heavy equipment, cranes, concrete pumps, plaster pumps, and their requisite skills. Technical, highly-trained skills are necessary and include survey work, steel building techniques, and fabrication of custom parts (Bradford and Sen 2005).

8.1 Military Criteria

In military assessments the materials for housing have four criteria: **Construction Time** (the full amount of time needed to complete the structure), **Transportability** (specifically, shipping on airplanes), **Personnel Resources** (in the case of military-run disaster relief operations, the availability of up to 12 soldiers for up to 96 man-hours), and **Durability** (at least one year). The rapidity of the build is also key.

The complex task of laying a proper foundation is not considered in this model (Bradford and Sen 2005). At the higher end, there are the three main methods of construction of Disaster Relief structures:

8.2 Construction Classification

8.2.1 Standard Construction with New Materials which incorporates cutting-edge materials that are stronger, lighter, non-corrosive, non-metallic, and utilizes them into traditional construction, for example, using styrofoam molds instead of masonry blocks in filled masonry wall systems

8.2.2 New Construction with New Materials which devises entirely new ways of building to maximize the effect of the new materials, for example, use wall and roof panel systems made from Fiberglass Reinforced Plastic components

8.2.3 Alternate Systems, based on developing technologies and advanced and functional design (Bradford and Sen 2005): for example, (EBT) Engineered Bamboo Technology, (SIP) Structural Insulated Panels, (ICF) Insulated Concrete Forms, (RWS) Radiant Wall Systems, Straw Bales, Cob, Adobe, Rammed Earth, and Michael E. Reynolds' Earthship(F).

8.3 Prefabrication Solutions

According to the Sri Lanka Institute of Policy of Studies (2006), the biggest problems in rebuilding were shortages of manpower and materials. Prefabricated pieces solve this issue by lessening the time needed to build structures (Karunasena and Rameezdeen 2010). The utilization of portable prefabricated components by a motivated affected community rejuvenates the local economy and maintains local social and cultural norms. (Karunasena and Rameezdeen 2010). An efficient approach would be the implementation of open-prefabrication systems, where standardized components are manufactured in local factories and transferred to the construction sites of temporary dwellings. Like Lincoln Logs or an Erector Set toy kits open-prefabrication systems allow various possibilities of an assembly into indifferent housing forms and configurations (Karunasena and Rameezdeen 2010) that can be built to suit the needs of the affected community.

9.0 Logistics of Reconstruction

The state of deficient sanctuary limits not only quality of life but also human development; and suggested three areas to pursue: Systems approach to housing policy, planning, programming, and management; a commitment to culturally-sensitive awareness in both architecture and design; and the inevitable expansion in improved technologies, materials, and further economic impetus. (Hartkopf 1984). His major objectives are: "maximize utility with minimal means; maximize material utilization with minimal effect on the environment, enable almost immediate response to emergency situations, maximize amenity to the users with minimal means and materials (Hartkopf 1984)." The vast diversity of potential misfortunes make the development of one single answer to sheltering populations impossible (Hartkopf 1984).

Technology has improved (Hartkopf 1984) and will continue to do so. Keeping an eye towards the long-term in a rapidly evolving field, in eighteen months the technology will all change; cutting-edge changes make costs go down and; efficiency goes up. Designers must consider reusability and upgradeability as essential features. By making it recyclable after the original building is dismantled, it has an extended life that will benefit not only the end-user but everyone in the chain of ownership; this avoids the environmental damage that occurs with the waste of disposable, unusable, often toxic parts

(Bashawri, Garrity, Moodley 2014). The components are a renewable resource able to be used in future build back better schemes.

10.0 "Build Back Better" Precepts

In Handbook on Housing and Community Reconstruction by Abhas K. Jha states,

- Do not just reconstruct houses, reactivate communities.
- Put owners in charge of reconstruction and address needs of tenants, and squatters.
- Provide an effective organizational structure.
- Use reconstruction to rethink the future and to conserve the past.
- Collaborate with communities, rather than just inviting their participation.
- Promote civil society engagement consistent with reconstruction policy.
- Use assessment and monitoring to improve reconstruction outcomes.
- Use reconstruction to mobilize disaster risk management policy reform.
- Manage financial resources and stabilize family finances.
- Avoid relocation, or mitigate all its impacts.
- Avoid sacrificing hard-won policies to facilitate reconstruction.
- Establish environmental sustainability as a reconstruction objective (Jha 2009).

The logistics and planning of reconstruction succeed, if there are four distinct job descriptions, one which works with the stakeholders to locate and secure resources, another, which manages the concentration, storage, security, and distribution of the available material, the construction companies themselves, and finally a grand strategic vision (Chang, Wilkinson, Seville, Potangaroa 2010). Construction energy, operating energy, maintenance energy and end-of-life energy, corresponding greenhouse gas emissions together equal the TLI (Total Lifetime Impact) of the structures. Temporary Housing's construction energy contributes 65% to its TLI. Facts illustrate this problem can be ameliorated by the use of recycled pieces and components, efficient structural materials, and light but durable wall coverings (Song, Mithraratne, Zhang 2016).

Durability is measured by the overall performance of the housing in extreme conditions and its requisite ability to return to mundane use without being compromised in any of its functions (Schilderman 2004). When rebuilding the dwellings the goal of improving their standard from pre-disaster times offers a significant opportunity to the community. In fact, this consensus is clear and has been adopted by UN-HABITAT, IFRC, and Habitat-for-Humanity.

On a tragically clean slate disaster gives people a new chance for achieving resiliency, if the necessary factors in their specific case can be identified in the early stages of the reconstruction process (Schilderman 2004). The field of Disaster Research, both from the anthropological and management corners, has broadened its scope to realize that reconstruction entails much more than a simple rebuild; it is an opportunity to re-create and set the community on a path towards improved and informed development goals.

Broad brush responses by aid agencies and governments, while the most common, is not necessarily ideal. Evidence exists that greater participation of stakeholders creates scenarios that they find more palatable and save money (UNHCR 2015). Getting their homes, roads, bridges rebuilt is the

people's main priority. Where they can be helped most effectively by those that assist them is with the technical knowledge needed to identify the disaster-prone areas and to avoid relocating to them (UNHCR 2015). Resilience is the heart of "Build Back Better." The goal is to reinstate communities in a way that reinforces them. The extended process of a community regaining its health, regaining its self-possession, and its real recuperation begins just as the emergency response begins its necessary retreat. Once rampant mortality, injury, and destruction are stabilized, the extended movement to normality begins. Aid agencies and governments should weigh the need to build back in a non-vulnerable way with the urgency of the people to get back to normal. Aceh, Indonesia, following the 2004 Indian Ocean earthquake and tsunami (UN 2015).

"The potential for the landscape to accommodate, support and even enrich the camp environment is barely considered."(C) There is much room for improvement in the current consensus on building Disaster Relief camps. The camps themselves, a brief stopgap in the thick of the storm, suffer from short-sighted official consideration. There has been a distinct lack of scrutiny by agencies and governments as to the effects of their own policies. The stakeholder is hostage to a system that considers the camp merely a conduit for getting the affected specific supplies, the re-establishment of the rule of law, an examination of the ecology of the disturbed land,(C) and rubber stamp of morality. Properly managed Temporary Housing can germinate into permanence and social stability (Karunasena and Rameezdeen 2010).

Effective disaster planning must recognize that the reconstruction is fundamental as the disaster will leave an indelible imprint on the area (Kovács and Spens 2007). When planning the rebuild, planners can incorporate areas previously allocated for development by the local authorities. While lessening the disaster's financial impact, the Temporary Housing becomes the center point of areas already deemed habitable and catalyzes the society's re-assimilation process. In addition to costing the affected government much less, it would keep down costs of future development (Karunasena and Rameezdeen 2010). Shelter that evolves from temporary to permanent saves money in its demolition and the relocation of its inhabitants (Karunasena and Rameezdeen 2010). To take existing materials to ameliorate existing shelters is not only pragmatic from an environmental sense but also an economic one. It is much cheaper (International Organization for Migration 2012).

Creating a central, social and cultural hub should be the main aim of design and planning for disaster settlements. The Temporary Housing can be built in such a clever way that it can easily morph into the settlement nucleus of the future permanent settlement (Karunasena and Rameezdeen 2010). In El Salvador 2001 earthquake reconstruction assistance was provided by fixing damaged homes and also by constructing new homes for displaced families (Kovács and Spens 2007).

11.0 Disaster Mitigation-Strategic Environmental Assessment and Environmental Impact Assessment (SEA/EIA)

Develop a shelter and settlement response plan including early recovery where possible in coordination with the relevant authorities, responding agencies and the affected population

Prioritise and support the return of affected households to their original dwellings or the site of their dwelling where possible

Assist those who are unable or unwilling to return to their original dwellings to be hosted by other households or to be accommodated within temporary communal settlements (O).

Recognition and identification of risks; ranking or evaluation of risks (response to significant risks: Tolerate/Treat/Transfer/Terminate); resourcing controls; reaction planning; reporting/monitoring risk performance; reviewing the risk management framework

Relief and recovery efforts must also consider future hazards and vulnerabilities in order to build communities back safer and promote stronger resilience. In many parts of the world, climate change is already beginning to have an impact on patterns of risk; traditional knowledge of hazards, vulnerabilities, and capacities needs to be combined with assessments of future climate risks.

- Recognition or identification of risks
- Ranking or evaluation of risks
- Responding to significant risks
- Tolerate
- Treat
- Transfer
- Terminate
- Resourcing controls
- Reaction Planning
- Reporting & monitoring risk performance
- Reviewing the Risk Management framework

Disaster mitigation can be especially criticized for failing to involve local people and their unique organizations, leading to inappropriate and ineffective solutions. Treating the symptoms rather than the causes of disasters, and sometimes aggravating the latter; formal approaches often fail to address the vulnerability, or make it worse (O).

The reasons for this are poor targeting, so that the most marginalized or affected often benefit less; susceptibility to manipulation, political interference and corruption; lack of integration, both of sectors, and of institutions, leading to poor planning and inefficiency.

Without the input of the affected shareholders, solutions are inherently flawed. Quick fixes are anything but. Operating on the proximate causes and not ultimate causes of disaster invites failure and can worsen already dire situations. Rigid methods do not "address the vulnerability, or make it worse." The dire specter of graft and malfeasance is exacerbated by breakdowns in cooperation with sectors and institutions, engendering unworkable, counterproductive plans.(O)

The Sphere Handbook emphasizes how monitoring a camp's environmental impact has several essential steps:

- Determine the scale of the damage in the affected area and gauge its environmental exposure and possible susceptibilities to further deterioration.
- Scrutinize the specific quantity of natural resources. Ration out limited materials, keeping in mind the current and eventual demands of the currently-affected society.
- Beware the detrimental effect on the limited resources that occurs from not only their utilization for construction, but also for the negative impacts of the construction process itself.
- Preserve as much of the native flora as feasible to combat erosion, maintain water retention, and cool the area.

- Reconstruct the environment at the end of the camp, unless agreed otherwise.(D)

According to UNHCR, the most thorough and operative method to reach successful results for both the settlements and their shelters:

- Create easier methods to determine the needs and disseminate them.
- Codify them with standards, devise further specific classifications, and promote new means of quantifying the situation.
- Take an accurate snapshot of the status quo. Utilize as much trained manpower as possible.
- Arrange for a methodical distribution of qualified management from the beginning. With the assistance of properly trained local authorities make certain that capacity of both shelters and settlements can remain within environmentally-feasible precepts.
- Bring in the most qualified specialists to survey the imprint of the settlement and to facilitate the progression of the settlement towards concrete goals and discernible stages.
- Utilize current methods to streamline logistics and get exact data on the specifics of the resources required.
- Consult most current UNHCR literature
- Remain flexible to the inevitable wrinkles.
- And above all, aid-givers and shareholders must maintain a dialogue (UNHCR 2015).

12.0 Conclusion of Literary Review

Immediate shelter comes with a price. With its urgent necessity, the speed with which it needs to be built, and the multifarious requirements that accompany it, acute environmental impacts manifest. Due to cheap construction and "unique functional requirements," Temporary Housing can be very environmentally-unfriendly.(5) Ideally, Disaster Relief shelters need to be impervious and adaptable to the possibility of recurring calamities (Bashawri, Garrity, Moodley 2014). The supplying and efficiency of shelters in specific instances are often obstructed by inter-camp tensions; hidden costs; overpopulation of the camps; grievous cultural oversights; reestablishment of settlements in ecologically-fragile, vulnerable locations; lack of amenities, the constraints of time; and not being suited to the specific climate (Bashawri, Garrity, Moodley 2014). It is a game of urgency amidst delay.

Disaster Relief victims need to be roofed, secure, hygienic, culturally-sensitive structures to live in until reconstruction allows them to move back into permanent housing (Bashawri, Garrity, Moodley 2014). Sensible design dictates that the shelters have a modularity: they can be broken down and built back up again with relative ease. Storage, when they are dismantled, is essential.(3) This allows for building stockpiles, ready for the next disaster and makes the rebuilding phase more effective.

Quantitative scientific measures such as "available space per person, number of individuals per toilet, food rations" dominate the discourse. This "potato stamp" method predominates today, laying down its grids and blocks, in the proliferating disaster camps around the world, categorically undervaluing cultural, ecological, or economic frames of reference.(C)

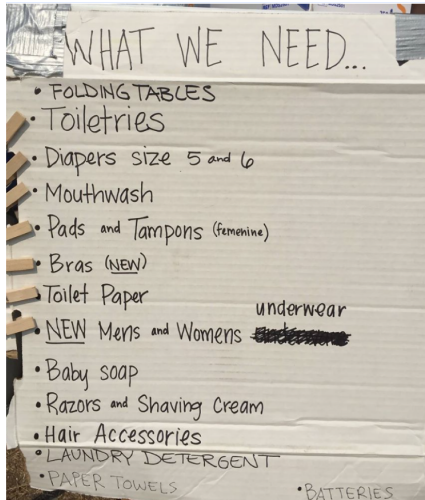

(Figure 2)

(©Reuters. Photo of sign from Hurricane Irma, Puerto Rico 2017)

Water, medicine, chlorination tablets, blankets, and protein biscuits and tents/shelters (Kovács and Spens 2007), feminine hygiene products, baby formula, underwear, and laundry detergent are the most needed supplies in a disaster. Temporary Housing requires durability and permanence in the face of extreme conditions. The design process must take this into consideration.(6) Getting the aid directly to the people is paramount. Often the people cannot get to a centralized distribution area, however well-located, due to their distressed state and compromised infrastructure (Kovács and Spens 2007).

In Puerto Rico in 2017 in the aftermath of Irma and Maria, thousands of packed containers stayed stranded on docking facilities piling up for weeks, filled with un-utilized supplies, including refrigerated medicines with shelf lives. The wrecked infrastructure of the island simply could not move these supplies to the numerous areas where they were sorely needed. Standardization in the labeling of the materials for the relief effort by the donors and portability of the supplies would streamline the process (Kovács and Spens 2007).

13.0 The Camp Layout

However, the standards culture which emerged from the 1980s ultimately owed more to quantitative measures like available space per person, number of individuals per toilet, food rations over functional aesthetics; and the 'cookie cutter' application of standard blocks regardless of environmental, cultural or economic context became a defining feature of the ever-growing camps and settlements littered across conflict zones the world over. Most refugee operations last longer than expected. Take this into account when selecting a site, planning the camp, and estimating resources and staffing. The footprint of early planning assumptions can endure for decades.

Hence, developing a comprehensive master plan for camp layout promoting community ownership and maintenance of water points, latrines, showers, facilities for washing clothes, and waste is paramount. The provision and performance of shelters in certain cases has been hindered by inappropriate climate, cultural differences, poorly located settings, camp-related social issues, expenses, overcrowding, poor services, and delays. The supplying and efficiency of shelters in specific instances have been obstructed by inter-camp tensions; hidden costs; overpopulation of the camps; grievous cultural oversights; re-establishment of settlements in ecologically-fragile, vulnerable locations; lack of

amenities, the constraints of time; and not being suited to the specific climate.(Tierney 2007). It is a game of urgency amidst delay.

Disaster relief shelters are commonly roofed, secure, hygienic, and in live-able locations, for people to utilize during periods of a disaster until they are able to move back to their permanent dwellings

13.1 Debris

Depending on their nature and severity, disasters can create large volumes of debris and waste. The waste can overwhelm existing solid waste management if such places even exist facilities and impact on other emergency response and recovery activities. Waste can have significant environmental and public health impacts and can affect the overall recovery process. Disasters create disorder. Wreckage and solid waste play a large part in this, inundating existing waste management systems, interfering with relief efforts, all the while generating a mounting threat to the local environment and public health.

It may happen that the population settles all over the place waste ground, gardens, parks, squares, parking areas, sports grounds, using anything that comes to hand, planks, plastics, tents, cars, containers, boats, railway wagons, buildings under construction, schools, public buildings. The sanitary situation may then rapidly deteriorate and it becomes very difficult to assess requirements. Brownfields, gardens, parks, squares, parking areas, sports grounds attract DR victims, and they begin to create shelter "using anything that comes to hand, planks, plastics, tents, cars, containers, boats, railway wagons, buildings under construction, schools, public buildings." In these circumstances sanitation degrades to the point of collapse, again interfering in getting to the core of DR.

13.2 Hygiene

"Ensure access to non-food items, shelter solutions (such as tents or shelter kits), construction materials, cash, technical assistance or information or a combination. Ensure dwellings or settlements are located at a safe distance from any actual or potential threats and that risks from existing hazards are minimized.

Ensure that debris resulting from the disaster is removed from key locations including the sites of damaged or destroyed homes, temporary communal settlements, essential public buildings and access routes.

Plan safe access to water and sanitation services, health facilities, schools and places for recreation and worship, and to land, markets or services used for the continuation or development of livelihood support activities (ALNAP 2006)."

Research and practice have long documented disaster relief challenges and how to overcome those challenges" Other work talks of these spaces as 'third spaces' where social actors reject 'hegemonic space and create spaces' for themselves (Soja 1996). These spaces range from ones created by social movements and community associations to those simply involving natural places where people gather to debate, discuss and resist, outside of the institutionalized policy arenas.

Throughout the affected area and at its borders are the spaces which are claimed by less powerful actors from the power holders, or created autonomously disregarding them. Cornwall refers to these spaces as 'organic' spaces which emerge 'out of sets of common concerns or identifications' and 'may come into being as a result of popular mobilisation, such as around identity or issue-based

concerns, or may consist of spaces in which like-minded people join together in common pursuits' (Cornwall 2002).

13.3 Location Permanence

Most refugee operations last longer than expected. Take this into account when selecting a site, planning the camp, and estimating resources and staffing. The footprint of early planning assumptions can endure for decades. For this reason, it is essential to develop a comprehensive approach "master plan" to camp layout, which promotes community ownership and maintenance of water points, latrines, showers, facilities for washing clothes, and waste.

The recommended space allocation for a complete camp of 20,000 is given as 35-45 square meters per person. The e Handbook multiplies this out for us, providing a total area of 90 hectares for a full camp. This translates to a population density of 220 to 330 people per hectare, comparable to downtown Seoul at the lower end of the spectrum, and Hong Kong at the upper extreme, making the ideal camp within the top the most densely-populated urban areas in the world.

14.0 Water in the Camps

A disaster relief setting amplifies the constraints imposed by the necessity of water for human life. The introduction of water to the site is complex. Hoops need to be jumped through: technical and social viability, permission-to-access, and permission-to-use, and the shareholder consensus. ((Mata 2010)Communal washing areas are a socio-cultural hub of any community. In a calamity when outward class distinctions quickly dissolve, it is a place people can come to restore their dignity and bond and strengthen their resolve to rebuild. A community that can congregate can find the will to survive.

15.0 Sanitation in the Camps

Disasters have the potential to create disorder. Wreckage and solid waste play a large part in this, inundating existing waste management systems, interfering with relief efforts, all the while generating a mounting threat to the local environment and public health (Brown, Milke, Seville 2011). Brownfields, gardens, parks, squares, parking areas, sports grounds exemplify the locations disaster victims seek out for temporary accommodation; they begin to create shelter "using anything that comes to hand, planks, plastics, tents, cars, containers, boats, railway wagons, buildings under construction, schools, public buildings." In these circumstances sanitation degrades to the point of collapse, again interfering in getting to the core of disaster relief (Bhave, Choudhury, Pemde, Mathur 2005) perpetuating many of the health issues.

16.0 Bamboo

16.1 Bamboo Characteristics

Regular bamboo is an easy-to-build-with, stands up well to both wind and earthquakes, is inexpensive, quickly replaceable material that lends itself well to the building of smaller less durable buildings. Historically the difficulties in joining pieces together, limited data from scientific study, and its exclusion from most building codes have prevented it from mainstream, worldwide use. Buildings that demand a low-mass-to-flexibility quotient are the most common types of structures built with it. Its outer shell's humble appearance hides a very high resistance to tension.

It grows at a very quick rate. *Guadua angustifolia* bamboo is a fast-growing Gramineae (true grasses), not plant, shooting up 13-14 centimeters per day. It grows abundantly, quickly and cheaply in China, Vietnam, Bangladesh, and Thailand. Some Asian varieties can grow up to a meter per day. *Gigantochloa atter* is one of the strongest tensile strength bamboo species from Indonesia, the bottom of the stalk of *Dendrocalamus asper* with a very high compressive strength parallel to grain, the top stalk of *Dendrocalamus merrillanus* measures up with one of bamboo's highest flexural strengths..

Bamboo plays a large role in sustainable cropping system for low mountain foothills, reducing soil erosion, and creating sustainable farming systems throughout Asia. The rhizome mat of bamboo, which continues to live after each harvest, protects the ground from erosion.

Bamboo can graduate from being the spurned stepchild of architecture, especially where it originates in Asia, centuries of experience with it bearing the onus of "poor man's timber" have changed in the past thirty years with the advent of new methods and technologies melded with ancient techniques perfected over centuries. Only recently have the mechanical properties of bamboo have been scientifically tested, where canes cost as little as a dollar each. In Bangladesh, people do not consider it a long-term material. In Vietnam it is used to create baskets, tableware, and furniture. Bamboo building is suitable in climates such as most of Asia, where no winter exists.

16.2 Building with Bamboo

Utilising the reinvented material Engineered Bamboo Technology (EBT) with a structural strength comparable to A36 steel can be used for plates, structural shapes, girders. It does support comparable weight allowances. Once bamboo has been treated with borates it is ideal for buildings. The bamboo sequesters and store the carbon The bamboo plant itself sequesters up to 12 tons of CO₂ per hectare. It releases 35% more oxygen than equivalent areas of trees." Total Lifetime Impact (TLI) construction energy will be less than the 65% to its TLI, due to the carbon sequestration. (Oliver-Smith 1996).

A bamboo house is a good place to stay during a hurricane or an earthquake, provided the house has been built with proper care. This attribute of bamboo is credited from its great capacity for seismic shock absorption, which makes it particularly useful in earthquake-prone areas. In April 1991, twenty bamboo houses built for the National Bamboo Foundation in Costa Rica suffered no structural damage from a 7.5 Richter scale earthquake, despite being directly over the epicenter. In the 1991 Costa Rica earthquake, many concrete structures collapsed in a 7.7 earthquake, while the twenty or so bamboo houses nearby remained standing and undamaged (Oliver-Smith 1996).

16.4 Tensile Strength & Compression Strength

The Tensile Strength of bamboo is close to better quality hardwoods and the Compression Strength is even higher than than wood. By counting their strength per unit weight, the tensile strength of bamboo is three to four times as high as steel, according to the China Bamboo Research Centre. With precise methods of treatment, it is extremely durable strength to weight ratio exceeds that of brick and timber while its tensile strength exceeds that of common steel. Bamboo with low moisture content has a higher compressive strength than bamboo with high moisture content. Structural strength comparable to A36 steel can be used for plates, structural shapes, girders, and it should support comparable weight allowances.(P)

16.5 Disadvantages of Bamboo

It has limited natural durability, a lack of structural design data, exclusion from building codes, and in its untreated state is sensitive to attack from insects and fungus. To be a viable long-term construction material, it must be treated against them.

It is notorious amongst craftsmen and builders across Asia for the difficulties in joining separate pieces together effectively. Round sections have a tendency to crack thus complicating the creation of joints and supports. There are too few contractors with experience in modern engineered bamboo construction.

"Because of the strength, sustainability, and its variety of colors and finishes, green bamboo, dried bamboo, or lacquered, the options for design are extremely large. Bamboo can divide a room, act as structural support, become furniture, or be used as a decorative lace-like lattice around a window. It can add mass, layering, transparency, depth or enclosure. Essentially bamboo can perform most of the things that timber is used for in building but in a novel manner, being tubular and moderately flexible by using engineered beams, cross-laminated panels, and new joining methods." (Yee 2006)

17.0 Bamboo Architecture/Revival of cultural techniques

17.1 Vo Trong Nghia Method of Vietnamese Engineered Bamboo preparation

"Control the accuracy of the construction by applying unit-frame prefabrication." -VGT

The bamboo used in Nghia's projects is treated so that it can last for decades, first by heating and bending the bamboo stalks into shape, and then soaking them in mud to reduce the sugar inside so that it doesn't become a breeding ground for insects or bacteria. The stalks are then smoked to create a carbonized layer which further protects it from the elements. Soaking in mud, submerge it into the river for 3-4 months. Burn the outer cover, the husk, of the rice plant, and then use that smoke to smoke the bamboo until the bamboo is black from the process. Used like timber, it lasts 30-50 years.

Treated so that it can last for decades, first, heat and shape the bamboo stalks into shape, and then soak them in mud. Submerge it into the river for three to four months to reduce the sugar inside so that it doesn't become a vector for insects or bacteria. Burn the outer cover of the rice plant's husk to smoke the bamboo black and create a carbonized layer which further protects it from the elements, then it can be used like timber. It will last 30 to 50 years, like timber, and is as strong as A36 Steel. Processed in this fashion it is ideal for the creation of premade grids, arches, trusses, and boxes.

17.2 CLC Thai Method Engineered Bamboo preparation

"For construction use, mature bamboo between 3–5 years old is selected. It shrinks less when dry and its starch and sugar contents are low so there is less chance of insect infestation. Upon arrival at CLC, the bamboo is separated according to usage. The thicker, more mature bamboo species 'pai tong' *Dendrocalamus asper* and 'pai hok' *Dendrocalamus hamiltonii* are used for structural columns and beams.

Depending on the diameter of the bamboo, different sized drill bits, attached to a long steel rod, are used to drill through the center of the bamboo culm throughout its whole length. This is to longitudinally penetrate the bamboo's nodal diaphragms before the natural preservation treatment.

Here at the bamboo treatment pool, the bamboo soaks in a borax and boric acid solution for 7 days to allow the salts to fully penetrate the inside "meat" of the bamboo. (Borax or sodium borate is a

soft, colorless, powdery mineral that dissolves easily in water. It is a natural insect repellent and preservative.). After about one week, the bamboo is pulled from the pool and stacked vertically so the preservation solution can drain from the bamboo and be recycled in the pool. Next, the bamboo poles are left to bask in the sun for 1 week depending on the amount of sunlight here in Chiang Mai. Then we rotate the bamboo poles daily to avoid cracking. The sun bleaches the bamboo to a natural golden yellow color that is more attractive as bamboo construction material. The last step of the bamboo treatment, the bamboo poles are left to dry slowly in a cool, dry place until they are used for bamboo construction (P).”

17.3 Borate Treatment

Bamboo is sensitive to attack from insects and fungus and must be impregnated or treated with a Borax solution. To avoid a fungal attack, the relative moisture content must not be over 20%. Borax or sodium borate is a soft, colorless, powdery mineral that dissolves easily in water. It is a natural insect repellent and preservative.

By treating it with Borates the bamboo acquires an immunity, it did not possess ever before. Unlike most organic insecticides that attack the nervous system, borates are a systemic poison that destroys the digestive tract of the organism. As a result, it is impossible for the species to develop immunity and borates will kill any organism that ingests the chemical.

17.4 Maria Yee Method of Constructing Bamboo Joins

“Coat the tenon and/or corresponding mortise with an adhesive and insert the tenon into the corresponding mortise; Cure the adhesive; and, finish the assembled parts. The mortise & tenon joining step may include forming butt joints, lap joints, tongue-and-groove joints, dado joints, dowelled joints and dovetailed joints. The mortise & tenon joints utilized may include both open, or through joints, blind or closed joints, and joints that are mitered. The mortise and tenon joints on the components may be square, trapezoidal, circular, elliptical, or arcuate trapezoids.(Yee 2006)”

17.5 Architect Simon Velez Method of Constructing Bamboo Strut Joins

"I make a hole in the chamber. The bamboo has many chambers. It's a material wood, but it is hardwood, so with a drill, I open a hole the size of a bottle. I cut a piece upon it, so I pour cement mortar inside there after the bolts and the strap already in position, and it makes a very strong joinery, the best." Simon Velez, Architect, Columbia

18. Application (Methodology): Portable Off-grid Washing Facility (POWF)

"A demonstration building acts as a testbed for advanced building technology that aspires to accelerate the uptake of new technologies in the construction industries by providing visibility of these technologies, and then, demonstrating their levels of competence within an integrated framework to future developers and owners, thus clarifying doubts and enhancing receptivity." H.W. Kuaa

The POWF is a self-contained package-able portable building. Off-grid, powered by current cutting-edge solar panels, and taking full advantage of the millennium's vastly improved batteries. It is able to wash clothing for up 450 people a day. This serves a very important role in the increasing number of dispossessed, uprooted people throughout the world. The ability to clean clothes and

bedding is the enzyme that can improve the situation. Women and children are freed from the onerous, inefficient and time-consuming task of effectively managing the hygiene in disaster relief camps. Without devices such the POWF the camps often morph in to large-scale slow-motion disasters, the least of whose worries is the bedbugs ravaging their flesh night after night.

My application, based on my research, is the design and then construction of a Portable Off-grid Washing Facility (POWF). Empower people by giving them the tools to reconstruct their lives after a climactic upheaval or conflict between people dismantles their stability, by teaching them the requisite skills. while monitoring the scene to create conditions for the good of caregivers and afflicted alike.

My shelter can be set up as an initial emergency shelter maintain its effectiveness through the stages of transitional to finally durable status. My application is a component-based washing facility from POWF fulfills half of UNHCR's Public Health Strategic Objectives 2014-2018 by "ensuring refugee populations in camps have access to quality sanitation and hygiene," while respecting "the right to safe water and sanitation."

The POWF is a building that is comprised of modular, triangular bamboo struts for a simple-to-assemble structure that fits, disassembled, into a standard 20' dry freight container (CTU). The container can be brought to the disaster's edge and if necessary its contents can be hand-carried 1500 meters, as the majority of the kit's pieces are less than 60 kilos per piece, making it possible to move and assemble in a short period of time in a GIS-located spot attached to a dependable, filtered water source with a solar orientation that receives at least 5.5 hours of sun. All of the components are durable and reusable.

A battery-and-solar power array forms the adjustable-angle roof to collect and store energy that will power a clothing and bedding washing facility. Excess power will be used to charge phones and computers, run WiFi, light 20 LED lights, a small water purifier, and a refrigerator to store medicines, with a standard swimming pool water pump to run water across the roof to gain even more heat for the pre-wash water. This design will approach potential problems with birds by using small spinning mirrors hanging from the sides, and it will address lightning by installing a lightning rod.

18.1 Solar Panels Electricity Calculations in POWF

12 Sun Power X22-360 Solar Panels (22%) efficiency 220 Watt (per square meter) Panels x 18.94342426 square meters =
4167.55 W power output.

Fronius Smart Meter Control Box- 1.2 W

Large Cellphone charger - 90 W

Medicine Refrigerator - 55 W

20 LED lights - 180 W

Water Purifier- 7 W

Water Pump- 32 W

Total= 365.2 W

The Tesla Powerwall 2 will store 13.5 kWh. The smart meter consumes 1.2 watts per hour, LED lights consume 180 watts per hour, the phone charger consumes 90 Watts, and the off-grid refrigerator uses 55 Watts.

During daytime operation on a sunny day the POWF generates 4.17 kW per hour. On sunny days energy is gathered by the solar panels at least eight hours per day of full sun, with 97.9% inverter efficiency, charging the batteries with the extra power generated by the solar cells; and then a night mode, with the LED lights on for twelve hours, when the system runs from the Tesla Powerwall 2 battery with 90% inverter efficiency.

1.50 kW goes to the washers, and 0.185 kW going to the various accessories, with the LED lights off. So we need 1.685 kW, however, we have to drive those things using our 97.9% inverter, which means we have to provide $1.72 \text{ kW} \times 0.979$ to get the required 1.685 kW.

POWF is generating an extra $4.17 - 1.72 = 2.45$ kW per hour to charge the battery. This will fully charge the Tesla Powerwall with its 13.5 kWh capacity in 5.5 hours.

Making an educated assumption that the washing machines only operate at half capacity (due to the increased as yet unquantified energy savings acquired by the use of the SWHA and by their inherent design), thereby consuming 0.75kW per hour overnight. As a result the solar electric system will run the POWF for close to 16 hours without sun.

POWF achieves significant bonus-power generation on sunny days because of placement and coloring of four water storage barrels, which, with the preheated water from the passive solar water heating array on the roof are 10-30c hotter than ambient temperature; the energy demand on the washing machines, which customarily use 80% of their energy on heating the wash water, is cut back by as much as 50%.

18.2 Washing Machines

In a standard, off-the-shelf Beko-brand washing machine, a standard load of laundry takes 55 minutes and needs 1.00 kWh of electricity in total. The POWF will store up to 832.79 liters of water, contained in 4 barrels. The station is open 12 hours per day and is in constant use throughout daylight hours. Even running 30-36# 5-kilo loads of laundry, the solar panel system generates excess energy, almost 1.10 kWh, and fills a powerful inducer-enhanced 13.5 kWh battery. Solar tiles on the roof along with the four barrels store and heat the water before it enters the washing machine increasing its efficiency

18.3 Eye-Catching Structure

Due to its 6.5-meter height, it will be iconic but not oppressive in the otherwise mundane sea of huts, tents, or makeshift shelters that surround it in all directions on the landscape of the disaster relief camp; it is a building with a practical mission of "restoration," to draw the affected people to a place where they can gather to refresh themselves after the direst of occurrences, to restore their dignity and finally their community.

18.4 Bamboo Struts

It will be made from modern engineered bamboo technologies that have taken the humble bamboo plant, long considered a second-rate building material due to its susceptibility to insects and weathering, into the 22nd century, reinforced in strength and durability due to a combination of ancient and modern techniques. The bamboo poles used are 8cm-12cm diameter Engineered Bamboo that has been carefully grown, groomed, and selected, and treated to extend both their strength and their durability in the modernized traditional Vietnamese method of Architect Vo Trong Nghia. They are joined together by the Simon Velez and Maria Yee methods, making Iron sock joins for each corner to hold the bamboo pole securely, creating modular portable pieces. The poles are bulky but they are

essential to the design because of their lightness, strength, and portability, and the fact that they have been enhanced to the point where they are as strong as A36 Steel.

The vertical sides of the struts are constructed from the bottom stalk of the *Dendrocalamus asper*. The horizontal sides are constructed from the top stalk of *Dendrocalamus merrillanus*, a triangular strut from a 6.0m *Dendrocalamus asper* pole, a 2.3m *Dendrocalamus asper* pole, and a 5.9m *Gigantochloa atter* pole. The bamboo poles are an 8cm-12cm diameter.

Engineered Bamboo that has been carefully grown, groomed, and selected, and treated, to extend both their strength and their durability in the modernized traditional Vietnamese method of Architect Vo Trong Nghia. They are essential to the design because of their lightness, strength, and portability, and the fact that they have been enhanced to the point where they are as strong as A36 Steel.

18.5 High-tech and low-tech Mix

With current advances in technologies such as improved photovoltaic panels, powerful batteries, and modern engineered bamboo technology based on traditional Vietnamese methods, we have the tools to construct a Portable Off-grid Washing Facility (POWF) by combining cutting-edge equipment and off-the-shelf materials. Of the methods of construction, POWF would qualify as Mixing Alternate Systems-style, based on its utilization of developing technologies and an advanced pragmatic design.

As for the assembly itself, again, according to the Military Value Parameters/Complexity Scale it would qualify as Good: After three-to-four hours of training, stakeholders could build it using minimal construction ability with basic electrical tools. In this case, people with competent skills in carpentry, plumbing, and masonry work are required in each build, with at least one basic carpenter per build as part of the construction crew.

In the case of POWF, a qualified electrician needs to handle the Photovoltaic system and electrical work. Recent technological advances in Engineered Bamboo Technology (EBT) and Solar Off-grid Systems (SOS), mixed with off-the-shelf existing technologies and systems, tempered with common sense drove the design to the form of a portable edifice, functional and yet accessible, symbolic, simple, and iconic.

Building the Portable Off-grid Washing Facility (POWF) as a demonstration building aimed at ameliorating the conditions in Disaster Relief camps. With current broad advances in technologies in improved photovoltaic panels, efficient powerful off-grid batteries, and modern (EBT) engineered bamboo technology, we have the tools to construct a POWF by combining bleeding-edge equipment with off-the-shelf materials with a dose of pragmatism.

The proposed shelter can be set up as an initial emergency and go through the stages of transitional housing to durable to semi-permanent to permanent. It is intended for use in equatorial zones, where it can reliably gather five hours-plus of full sunlight per day. The structure intends to be recognizable, to draw people's eye over the low horizon of tents in a camp, creating curiosity or attraction; a structure designed for cleaning whose main aim is to restore people's dignity after a disaster.

The Tesla battery, the central concrete base beneath the three washing machines, with the base struts buried in place will serve as stabilizers and counterweights to the top of the structure. A rooftop

passive solar water array will heat the water before it enters the washing machines increasing their efficiency.

18.6 Outer covering UNHCR Canvas

As it is designed for temperate/equatorial regions the covering is adequate. The covering is comprised of 165.66 m² standard UNHCR canvas sewn together into four larger panels that are in turn rolled up and down as needed. There is ample excess canvas contained to create more and additional designs.

18.7 SWHA (Solar Water Heating Array)

SWHA is comprised of 3.17 square meters of copper pipe running across exposed black surface area in the in the sunniest spot on the structure at 1.0 kW/square meter. Ignoring cooling effects, that will heat the water at about 0.003 degrees per second, or about 12 degrees centigrade per hour. The SWHA then releases the hot water downward fed by gravity to the washing machines. Including the re-radiation and the cooling effects of air movement and evaporation, the (SWHA) will heat the pumped water 20c–25c degrees above ambient to lessen the power load on the Beko washing machines which usually will expend 80% of their energy to heat water. In placing the water barrels above the machines, there is less energy used for pumping, as gravity does the work. In the event of a malfunction, they can be filled by hand. The heating element K320 in the figure below will not be alerted to turn on by the incoming water temperature sensor K310, substantially minimizing the amount of electricity the machine uses to heat the water.

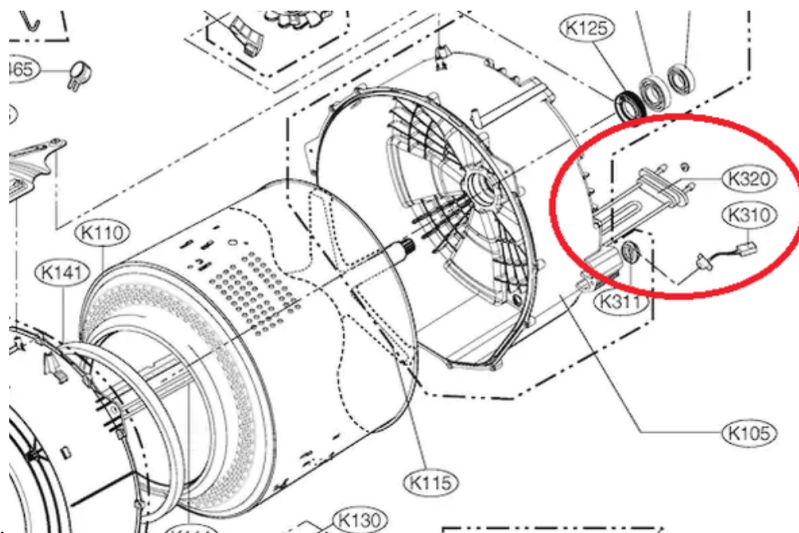

(Figure 2)

© Meko Washers

The solar power array rests on the adjustable-angle roof to collect and store energy that will power POWF. Excess power is used to charge phones and computers, run Wifi, light 20 LED lights, power a water purifier, a refrigerator to store medicines, and a strong water pump to run water across the roof to increase heat efficiency for the pre-wash water. © Meko Washers

The water pump must pump 1147.208 liters of water through the roof's water heating pipe system every 5 hours, 4 hours to avert running dry on the water. The weight of the amount of the water in the SWHA (Solar Water Heating Array) in 46.8m of copper pipe is 3675.69 cubic centimeters of water.

The pumps pump 286.802 liters up 6.5 meters every hour. POWF requires hookup to an adequate water supply either at its most basic to a filtered spring, hand pump, water pump, ideally, a metered or unmetered water system hookup. Each of the four barrel holds 208.2 liters equals a total of 832.8 liters of water, divided by the requisite 55 liters per wash for the "Eco-Cycle" = 15.14 5k wash loads per barrel. The daily end result of which is 1980 liters for garden greywater for banana trees after filtration.

18.8 Greywater Treatment

The SWHA then releases the hot water downward fed by gravity to the washing machines. They then wash clothes and bedding. Once the water is purged in timed cycles from the washing machines, the outflow of used washing machine greywater flows through the Gravel-Sand-Biochar barrels which lie half-buried in the ground with soak pipes extending to banana trees; they receive the water, gravity-fed, one load at a time, from the alternately-timed cycles of the washing machines, dispersed evenly between the two barrels, so as to not overflow the two 55-gallon barrels. Biochar has shown to effectively remove up to 70% of the Phosphorus from washing machines water (Berger 2012). The main concern would be to minimize detergent usage and utilize only HE brands. Soakaways and drainage into existing wetlands once deemed clean enough will take care of the water the plants cannot utilize.

18.9 Washing Machines

In a standard, off-the-shelf Beko-brand washing machine, a standard load of laundry takes 55 minutes and needs 1.00 kWh of electricity in total. The POWF will store up to 832.79 liters of water, contained in 4 barrels. The station is open 12 hours per day and is in constant use throughout daylight hours. Even running 30-36# 5-kilo loads of laundry, the solar panel system generates excess energy, almost 1.10 kWh, and fills a powerful inducer-enhanced 13.5 kWh battery. There will be a great deal of activity here: 12-15 hours of washing 30-36 loads of laundry minimum (150-180 kilos of bedding, clothing, and diapers) per day, and then the 'Bedlam' of hanging it to dry.

With POWF being open 12 hours per day, each wash load taking 55 minutes, with the three washing machines operating in staggered cycles to avoid electrical surge unhealthy for my electrical system design, I can expect 30-36 loads or 150-180 kilos of clothing per day: That translates to 750 t-shirts or a combination of 60-72 pairs of adult jeans; 60-72 shirts and 30-36 bed sheets; 60-72 pillowcases; 60-72 dish towels; and 60-72 small towels. This means that the water pump must pump 1147.208 liters of water through the roof's water heating pipe system every 5 hours, 4 hours to avert running dry on the water.

18.9 Complies with UNHRC Sanitation Standards

POWF does two things that comply with UNHRC standards; each unit can, with minimal power, handle the washing needs of 16-20 families per day. Its efficient, compact nature prevents a sprawl of the cleaning area and encourages other areas to establish POWF's in their areas. It also empowers the women and children, who customarily and historically have been bound to doing the washing for the community, by freeing them from the onerous task of the hand-washing of the bedding and the clothes. The social implications factor in at this point, and the freed-up female population will inevitably have a beneficial effect on the overall population. Women will have more energy to motivate and organize the camp. The children will have greater supervision, less idle time, and more opportunity to go to school. Involving the population in creating a structure for managing the cleanliness and health of the group increase their dignity and thereby their motivation. The effects can be far-reaching.

18.10 Hygiene Consideration

POWF fulfills half of the current UNHCR's Public Health Strategic Objectives by "ensuring refugee populations in camps have access to quality sanitation and hygiene," while respecting "the right to safe water and sanitation." Under the criteria for Sanitation, it adheres to Article 20 on Bathing and Laundry facilities. "Ensure that refugees have access to facilities for bathing, and laundering clothes and bedding. These facilities should provide privacy and dignity. If this cannot be achieved at the household level, design and locate communal facilities in consultation with users, notably women, adolescent girls, and the handicapped. Facilities should aim to meet the needs of small private communal groups of up to 16 households and avoid large public wash blocks."

POWF does two things that comply: each unit can, with minimal power, handle the washing needs of 16-20 families per day. Its compact 8.5m x 6.5m footprint prevents a sprawl of the cleaning area, and this encourages other areas to establish POWF's in their areas, and it also empowers the women and children, who customarily and historically have been bound to doing the washing for the community, freeing them from the onerous task of hand-washing clothes and bedding. Laundry can be done during the daytime allowing it time to air dry adequately in arid and semi-arid regions.

It also observes Article 27 concerning Empowerment. "Develop and run hygiene promotion programmes in full cooperation with refugees and the host population."The social implications factor in at this point and the freed-up female population will inevitably have a beneficial effect on the overall population. Women will have more energy to motivate the men and improve a lot of the children in the area, more time for ameliorating the area.

It is crucial to locate the POWF correct distance from disease vectors. As stated in Article 31 focused on High-risk vectors. "UNHCR field staff and partners must ensure that the environment is free of high-risk disease vectors. Take steps to drain bodies of stagnant water, and clean up any dumps of organic solid waste, feces, or other potential breeding sites for disease vectors." (UNHCR)

Involving the population in creating and managing the cleanliness and health of the group increase their dignity and thereby their motivation. The effects can be far-reaching. "(L)

POWF follows the UNHCR WASH principles: it is evidence-based, needs-based, technically sound, impact-oriented. priority-based, and integrated. It is based on the findings I found in my Literature Review, that there is a distinct gap in the providing for and creation of adequate facilities for displaced people to clean themselves, their bedding, and their clothing. Scaled, it can easily be tailored to allocate the resources to meet the needs of the population. Based on the current scientific evidence, and once built with basic operational guidance, it can be run by a small skilled and larger unskilled staff. It addresses the safe water, sanitation and hygiene needs of disabled individuals, men, women, and children of all ages.(J)(L)?

My shelter can be set up as an initial emergency and go through the stages of transitional to finally durable status. My application is to design a component-based washing facility from POWF fulfills half of UNHCR's Public Health Strategic Objectives 2014-2018 by "ensuring refugee populations in camps have access to quality sanitation and hygiene," while respecting "the right to safe water and sanitation." It is important to locate POWF at a distance from disease vectors.

18.11 The Structure

It will be made from modern engineered bamboo technologies (EBT) that have taken the humble bamboo plant, long considered second-rate building material due to its susceptibility to insects and weathering into the 21st century, reinforced in strength and durability due to a combination of ancient and modern techniques.

The heavy Tesla Powerwall 2, sand or rock inter-filled flooring, along with the base struts in place will serve as stabilizers and counterweights to the top. It will also have a rudimentary foundation. It supports a weight of a solar panel array weighing of 300 kilos, a lightning rod, a 50-kilo SWHA, 200 kilos of Roof Panels, 4 Canvas Awnings, attached at 100 kilos, dry, 4 Canvas Awning Bamboo Rods, attached, weighing 80 kilos totalling the weight borne by roof at 820 kilos.

18.12 Prefabrication/ Advantages of Modular Construction

I am building modular, triangular bamboo struts for a simple-to-assemble structure that fits, disassembled, into a standard 20' dry freight container. The container can be brought to the disaster's edge and if necessary hand-carried 1500m. The majority of the kit's pieces are less than 60+ kilos per piece, making it possible to be assembled in a short period of time in an adequate, GIS-located spot on a (dependable) (filtered) water source. The components are durable and reusable.

Of all the prefabricated shelter and containers on the current market there are many benefits with the creation of these permanent or semi-permanent structures; they are easy to maintain, long-lasting and become valuable reusable materials; The cons are their high unit cost, long and dangerous shipping times, a very long production time, numerous transport challenges, assembly challenges, rigid designs bordering on inflexibility and a total disregard for cultural and social norms, in addition to being difficult to cool. My design does not fall prey to these cons.(K)

UNHCR- How to reach results: develop a range of shelter models for all operational phases in urban and rural settlements, invest in research and development for alternative and innovative shelter options, develop standard formats and operating procedures for designing and implementing settlement and shelter strategies.

19.0 Bamboo Strut Joins

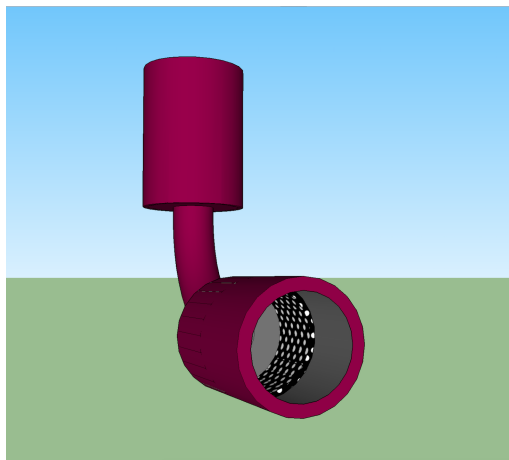

(Figure 3)

The joins are entirely theoretical at this point after much research I have ascertained this as the biggest gap the field of modular engineered bamboo construction. While historically this has been one of the main failings of bamboo, it is precisely for this reason that more research is necessary. The work of Vo Trong Nghia with his iron band fasteners and bamboo peg arrangements sits at one end of the scale of how to build with bamboo, creating large architectural forms from pieces woven like baskets from his meticulously groomed, trained bamboo, or Simon Velez's brute force creations of bolts, concrete, and steel pegs to form powerful rigid, sweeping structures. Herein lies the crux of the whole project, whether it succeeds or fails hinges on this one piece. If it is able to succeed where generations of builders have failed, it will propel the industry of bamboo construction far into the future. I am currently researching this further with a Nepali colleague to make an iron sock with a plastic padding inside to minimize the anomalies in the structure of each bamboo piece. Using 3D printing has also shown some promising possibilities and is under my consideration.

20.0 Tesla Powerwall 2 Battery

The batteries are essential in that they even out the power consumption. POWF only dependably generates electricity for 5 hours each sunny day, but can run laundry at any time because it is storing the energy from the solar panels in the batteries.

A battery-and-solar power array forms the adjustable-angle roof to collect and store energy that will power a clothing and bedding washing facility. Excess power can be used to charge phones and computers, run Wifi, light 20 LED lights, a small water purifier, and a refrigerator to store medicines, with a basic water pump to run water across the roof to gain even more heat for the pre-wash water.

21.0 Results

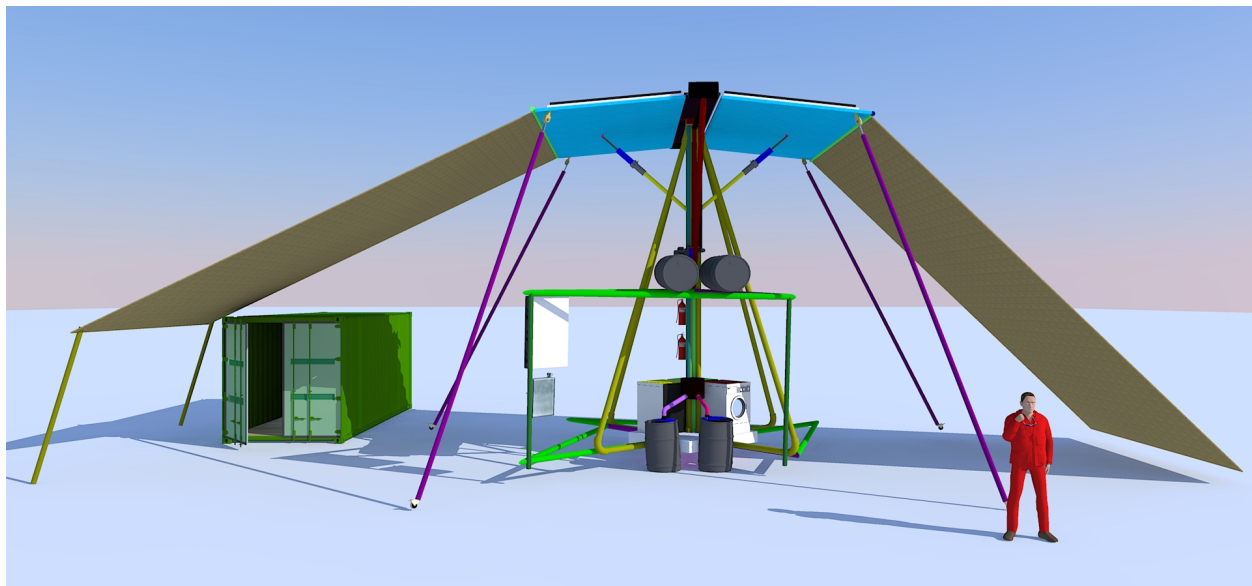

© Albert K. Muhleman

The results I achieved were the plans and the compiled lists of the necessary materials to build a Portable Off-grid Washing facility. I have discovered it is feasible to pre-build, pre-package and store a building capable of restoring the dignity to many people in times of crisis. The problems I encountered in

the course of my research were the reticence of the gatekeepers of such a cutting-edge field to readily share the information. The lack of existing technologies specifically in the area the joining of the bamboo technique. I discovered the current state of disaster relief also was a two-edged sword. Often communities that are not affected by a disaster are hesitant and even hostile to the unfortunate dispossessed newcomers who settle at their peril in the unaffected community's vicinity. Often the help is just enough to get the people moving again, away to other areas. If there is the sense that the newcomers plan to stay then an often hostile attitude manifests. This affects the ability of the unit to do its work, because in the state of lessened security the POWF is vulnerable, a technological prize that can excite jealousy and greed in neighbors of and denizens in camps alike. Without digging a moat and fencing in the POWF, counter to its very design, it is indeed a vulnerable insecure are. The option of including the container it comes packed in as repository for most of the valuable equipment becomes a necessity, lessening its range considerably. Perhaps one day when Man ventures onto other worlds this type of item, a portable off-grid washing facility can be put to use.

21.1 CHART OF MATERIALS

PARTS	WEIGHT (KILOS)	DIMENSIONS	VOLUME (CM3)	COST (\$)
Tesla Powerwall 2 Battery	276	115 x 75.5 x 15.5cm	134579	6600
(12) Sunpower X22-360 Solar Panels	341	(12) 104.6 x 155.8 x 4.6cm	899577	6600
(3) Beko WMB S1021 CS PT washing machines	192	(3) 84 x 60 x 40cm	604800	1500
Frankus Smart Meter	2	9 x 7 x 7cm	441	320
(2) 1-gallon UV Resistant Marine Grade Epoxy Resin	5	(2) 30 x 12 x 12cm	8640	100
(2) Beige, green olive UNCR Supply Catalogue Canvas	145	*	16219	440
(4) 6m PVC SWHA pipes	48	(4) 630 x 2.2 x 2.2cm	12003	120
(4) Heavy Duty Military Canvas Duffie Bag (30" x 50")	10	(4) 130 x 80 x 180 cm	7488000	42
(2) Amerex B500 Fire extinguishers	10	(2) 19 x 11 x 39 cm	16219	104
Lightning Rod	1	1 x 1 x 50 cm	50	15
Aus RT-AC88U WiFi Router	1.5	*		430
Beshway 800 gallon Flowclear Filter Pump	6.5	28 x 28 x 36cm	28224	72
SIIG 90W Smart 10-Port USB Phone Charger	1	32 x 18 x 9cm	5184	50
Aus RT-AC68U WiFi Router	2	2.2 x 1 x 1.6	4	430
Ethem Reflex 350 UV Water Purifier	2	11 x 39 x 15 cm	6435	125
(3) 280cm Bamboo Supports for Water Barrel Rack	21	280 cm (Diameter: 8 cm)	14075	24
(2) Samonite 7700 Series Rectangular 6' Folding Table	27	(2) 183 x 77 x 8 cm (folded)	225456	220
(4) Skolnik CQ5514 55-Gallon Closed Head Carbon Steel Drums	110	(4) 83 x 58 x 58 cm	1715640	360
(20) LED lights with fixtures	6	*		80
ARB Elements Weatherproof 63 Quart Fridge	32	44 x 82 x 49 cm	176792	1290
(2) Roof support Bamboo Triangular Struts	80	Triangle sides: (2) 225 x 300 x 375 cm (Diameter: 8 cm)	90478	
(4) Triangular Buttress Struts affixed with Joins	120	Triangle sides: (4) 624 x 230 x 580 cm (Diameter: 12 cm)	648726	
(4) Hinge-topped Bamboo Support Poles with locking roller wheel bases	80	(4) 622cm (Diameter: 10cm)	195407	
(2) Bamboo Poles Roof Adjustors attached to pistons	50	(2) 158 cm (Diameter: 10 cm)	24818	
Central Bamboo Backbone Strut	15	580 cm (Diameter: 14 cm)	89284	
(4) Bamboo Base Triangular Struts	100	Triangle sides: (4) 232 x 441 x 337 cm (Diameter: 10 cm)	349973	
(4) Covering roller bamboo poles	40	(4) 500 cm (Diameter 8 cm)	100531	
(4) Synthetic Rope rolls	4	(4) 30 m x 0.8 cm		50
Electrical Cables/Breakers	30	*		400
(9) 15mm diameter 5.2m sections of Copper Pipe	18.5	520 cm (Diameter 1.5 cm)	1170	175
(6) Heavy-Duty Hammocks	24	*	300	120
Frankus Symo Hybrid 5.0-3-S Inverter	20	65 x 44 x 21 cm	60060	120
(2) 238 x 64 x 0.6cm Clear Lexan Exell-D Polycarbonate Sheets	25	(2) 238 x 64 x 0.6cm	18278	532
(8) 238 x 122 x 0.6cm Lexan Exell-D Polycarbonate Sheets	176	(8) 238 x 122 x 0.6 cm	139373	3210
(2) 1-gallon UV-Resistant Marine Grade Epoxy Resin	5.2	(2) 30 x 12 x 12 cm	8640	100
Assembly Tools in Pelican Case	100			
(12) 20kg Bags of builder's concrete	245	(12) 7.5 x 36 x 51 cm	165240	140
(4) Hoet, (4) Shovels, (4) Picks	40	44 x 82 x 49 cm	176792	
Roll of Fiberglass Cable	100	12 x 12 x 16cm	2304	
(#) Bio-Char	(#)	(6) 7.5 x 36 x 51 cm	82420	
(#) Sand	(#)	(6) 7.5 x 36 x 51 cm	82420	
TOTALS	2480		13588952	23771
(4) Heavy Duty Military Canvas Duffie Bags				
<i>within the four bags-</i>				
Zip Ties				
Electrical Cables/Breakers				
(6) Heavy-Duty Hammocks				
(4) Synthetic Rope rolls				
(20) LED lights with fixtures				

(Figure 5) © Albert K. Muhleman

From my Results Chart of Materials, I used my skills in movie production techniques to put together a comprehensive list of the material needed to complete the mission. Packed in to a standard 20' (CTU) Container the pre-assembled modular triangular struts made from engineered bamboo take up the majority of the space. Followed by the extra-durable Polycarbonate sheets that form the roof for both the Solar Water Heating Array that also comes pre-assembled, the washing machines packed in their original packing boxes. The various electrical accoutrements: the WiFi router, the phone charger, the filter pump, the water purifier, the inverter all packed in Pelican cases, the cables, ropes, zipties, electrical breakers, hammocks, and the canvas for the roof flap coverings are all packed neatly into 4 heavy-duty military-grade long duffel bags. The fire extinguisher, barrels, extra pipes, and long-handled tools occupy a substantial portion of the container's load. The bags of BioChar, Sand, and Concrete fill in the gaps.

I am confident of my weight load calculation of 2480 kilos, with my lightest item, the lightning rod weighing in at one kilo, and my heaviest being the Tesla Powerwall 2 battery that stores the solar energy that powers the edifice. The canvas, the washing machines, the main bamboo support struts are the other large-weight items. A great deal of weight bears down here from the concrete, sand, solar panels, and roofing materials, but that is dispersed enough in separate manageable pieces so that it is easily transportable by a single worker.

In terms of volume I was pleasantly surprised to say that with current calculations I could easily put 2 POWFs in a 20' Container. The duffel bags, packed, take up the majority of the space, followed by the steel drums, the solar panels, the washing machine, the folding tables, the long tools, and the concrete.

The bamboo struts are designed in dimensions that will fit easily into the containers dimensions of 589.5 x 235.0 x 238.5 cm or 33.04 cubic meters, with one POWF currently occupying only 13.59 cubic meters.

In terms of money the unit costs \$23,771.00 with the notable exception of the data on the specialised Engineered bamboo production methods and the building and improvement of the Iron Sock joins. This is the open section that needs more study, more data, and more time in my project. I am scheduled to continue my studies in these areas this summer at the LATRA Innovation camp run by Aris Papdopoulos.

The building of the design initially was very general; as criteria manifested, it distilled into its current form. Structurally, the biggest concern is the 'joins' of the bamboo struts. I am not convinced of the durability of the Columbian architect Simon Velez's pioneering work in that area. 3D printers can perhaps print the 'joins' from metal, customized for each unique piece of bamboo in the modular-strut construction phase that occurs before the pieces are boxed up for delivery to disaster zones in a cost-effective way in the future.

22.0 Discussion

In the 21st century the increasing pressures of population, poor urban planning and climate change will create the 'perfect storms' to consistently yet unpredictably unsettle the planet and its inhabitants. In this tumultuous time, the topic of Disaster Relief becomes more important; increasing

population, irrefutable change in the weather patterns, decreasing impact and density create a perfect storm for increasing severity and impact. Call just to the rescue operation and natural disasters can provide the basic building blocks for the restoration and really ration areas ex post facto there are several main types of Disaster Relief camps.

The border where man in the land meets nature is instantly, uncomfortably, redefined to due the lethal vagaries of disasters. Not planning to encounter them men build at their peril. With the facts of climate change in population growth, the impact increases exponentially. The leveling hand nature gives man chance to rebuild, to renovate the past mistakes and bad planning build back resilient, more secure communities.

After my research I discovered the common denominator, the gap, where an enzyme that can change the process beneficially can be inserted, a creation of a center where people can get themselves and their clothing and their bedding cleaned is the first step in putting them back on their feet. There is a better way to maintain cleanliness. Cleanliness is important to morale. Clean clothing is a tough commodity like shelter it is a basic part of human dignity. It is in effect shelter for the body. My application solves this problem on a small scale for 400 people.

Essential needs once met, food, water, shelter, can easily lose their restorative powers to the vectors of easily-avoided disease by unclean conditions that nullify these boons. Efficiency often morphs from simplicity best; least is often most. Empowering the disempowered by giving them the tools to achieve their own goals results is a win-win situation. My application, based on my research, is the construction of a Portable Off-grid Washing Facility (POWF).

POWF fits the current scheme because its precise pragmatism improves the situation by getting right back to work in order to restore the community, leastways with the immense morale boost of getting clean and staying clean not just for health, but also, dignity.

Empower people by giving them the tools to reconstruct their lives after climactic upheaval or conflict between people dismantles their stability, teaching them the requisite skills and move while monitoring to scene creating conditions for the good for caregivers and afflicted alike.

In the 21st century the increasing pressures of population, poor urban planning, and climate change will create the "perfect storms" to consistently yet unpredictably unsettle the planet and its inhabitants. In this tumultuous time the topic of disaster relief becomes more important; increasing population, irrefutable change in the weather patterns, decreasing impact and density create a perfect storm for increasing severity and impact.

The border where man in the land meets nature is instantly, uncomfortably, redefined to do the lethal vagaries of disasters. Not planning to encounter them men build at their peril. With the facts of climate change in population growth, the impact increases exponentially. The leveling hand nature gives man chance to rebuild, to renovate the past mistakes and bad planning build back resilient, more secure communities.

After my research I discovered the common denominator, the gap, where an enzyme that can change the process beneficially can be inserted, a creation of a center where people can get themselves and their clothing and their bedding cleaned is the first step in putting them back on their feet.

In my research, I discovered the common denominator, the gap, that the enzyme that can change the process beneficially. I firmly believe that the creation of a center where people can get themselves and their clothing and their bedding cleaned is the first step in putting them back on their

feet. There is a better way to maintain cleanliness. Cleanliness is important to morale. Clean clothing is a tough commodity like shelter it is a basic part of human dignity. It is in effect shelter for the body. My application solves this problem on a small scale for 400 people. The POWF may only be one method of many in the amelioration of the refugees and displaced peoples' lot, but I am confident based on my research that it is just the right amount of force at just the right moment to engender positive, quantifiable change for the better.

Two areas have room for presently unquantifiable efficiency improvement factors, the extending roof panels' advantage from manual roof angle adjustment and the heat bonus attained on sunnier days by a passive water heater attached to a water pump to run the water along the top of the roof.

23.0 Conclusion

It has been a long road from Lisbon, Portugal 1755, to Puerto Rico, 2017, and yet the far-reaching effects and increasing severity of future inevitable disaster force us to consider, face, and construct solutions to imminent threats. Preparation based on past observation fix problems before they start. At any given moment we can be victims of chaotic upheaval. We would do well to prepare and help others as if we were preparing and helping our own loved ones. The readiness to face disasters with proactive strategies in place, materials stored and at-the-ready, logistical considerations ironed out before, not during, disastrous events is ideal.

By factoring inevitable, unpredictable events into our social fabric is essential. The increasing numbers of people, the unpredictable weather, the competition for the limited tools and resources needed to solve problems guarantee that we will be faced again and again with the challenges until we develop methods to face them down and build back better more resilient less vulnerable communities.

The inevitable destruction of faulty, inefficient systems comes with a high price, yet not as high as repeated failures to accept and create solutions amidst the chaos. In conclusion, I emphasize the pragmatism, the synthesis, the functionality of my POWF design. Imagine containers on docks pre-packed ready to dispense by high tech and low tech means directly to the epicenter of post-disaster situations. Roll in with the boxes, unpack, dispense the responsibilities, empowering the recently disempowered populations to get immediately back to the task of re-establishing first their dignity and by extension their community. My simple design synthesizes current high tech and low tech things to create an enzyme that creates a critical mass necessary. It is the most efficient expedient method. The waves of a disaster move out in all directions, not just the earth physically shaking but also the invisible skeins of society, government, religion are shaken as if with a spiderweb's sensitivity: a web both sinuous and strong and fragile and amorphous.

At any given moment, any group of people, regardless their cultural or economic status, can be forced into primal survival conditions with as little warning as a tide going out too fast on a day at the beach, a rumbling from the volcano, or a change in the direction of the lightest of sea breezes.

The conclusion I draw after these months of research boils down to one essential truth: preparing for disasters by creating efficient and mobile toolkits that are packed and ready-to-go is the biggest defense against the capricious vagaries of the unpredictable and sudden events that strip away the enfranchised modern life that we take for granted. In helping others; we help ourselves: because the drowned man you pull from the sea, or the starving boy you feed, or the ragged family of six whose

bedding you clean, might well be the one who, in turn, pulls you from your burning office building, digs you out from the rubble of an unforeseen war, or shares their last crust of bread with you in famine.

-Albert Kenton Muhleman, III

BIBLIOGRAPHY

1. Abulnour, Adham Hany. 2014. "The post-disaster temporary dwelling: Fundamentals of provision, design and construction." *HBRC Journal* 10 (1):10-24.
2. Ahmed, Iftekhhar. 2011. "An overview of post-disaster permanent housing reconstruction in developing countries." *International Journal of Disaster Resilience in the Built Environment* 2 (2):148-164.
3. Alshehri, Ali, Brian Parrott, Ali Outa, Ayman Amer, Fadl Abdellatif, Hassane Trigui, Pablo Carrasco, Sahejad Patel, and Ihsan Taie. 2014. "Dust mitigation in the desert: Cleaning mechanisms for solar panels in arid regions." *Smart Grid Conference (SASG), 2014 Saudi Arabia*.
4. Anh, Tran Tuan, Tran Van Giai Phong, and Martin Mulenga. 2014. "Community consultation for climate resilient housing: A comparative case study in Vietnam." *International Journal of Disaster Risk Reduction* 10:201-212.
5. Arsalan, H, and N Cosgun. 2007. "The evaluation of temporary earthquake houses dismantling process in the context of building waste management." *International earthquake symposium. Kocaeli, Turkey*.
6. Atanda, J. 2015. "Environmental impacts of bamboo as a substitute constructional material in Nigeria." *Case Studies in Construction Materials* 3:33-39.
7. Aysan, Yasemin. 2013. *Disasters and the Small Dwelling: Perspectives for the UN IDNDR*. Routledge.
8. Bashawr, Abdulrahman, Stephen Garrity, and Krisen Moodley. 2015. "Life Cycle of Disaster Relief Shelters." *5th International Conference on Building Resilience*.
9. Bashawri, Abdulrahman, Stephen Garrity, and Krisen Moodley. 2014. "An overview of the design of disaster relief shelters." *Procedia Economics and Finance* 18:924-931.
10. Berger, Christina. "Biochar and activated carbon filters for greywater treatment." (2012).
11. Bhave, Swati Y, Panna Choudhury, Harish K Pemde, YC Mathur, and IAP Task Force on Child at Risk. 2005. "IAP workshop on disaster management practices: recommendations and IAP plan of action." *Indian Pediatr* 42 (9):887-903.
12. Bradford, NM, and R Sen. 2005. "Multiparameter assessment guide for emergency shelters: Disaster relief applications." *Journal of performance of constructed facilities* 19 (2):108-116.

13. Brown, Charlotte, Mark Milke, and Erica Seville. 2011. "Disaster waste management: A review article." *Waste management* 31 (6):1085-1098.
14. Cornwall, Andrea. "Making spaces, changing places: situating participation in development." (2002).
15. Chang, Yan, Suzanne Wilkinson, Erica Seville, and Regan Potangaroa. 2010. "Resourcing for a resilient post-disaster reconstruction environment." *International Journal of Disaster Resilience in the Built Environment* 1 (1):65-83.
16. Davidson, Colin, Gonzalo Lizarralde, and Cassidy Johnson. "Myths and realities of prefabrication for post-disaster reconstruction." In *4th International I-Rec Conference 2008 Building Resilience: achieving effective post-disaster reconstruction*. 2008.
17. Drury, A Cooper, and Richard Stuart Olson. 1998. "Disasters and political unrest: An empirical investigation." *Journal of Contingencies and Crisis Management* 6 (3):153-161.
18. El-Anwar, Omar, Khaled El-Rayes, and Amr Elnashai. 2009. "Optimizing large-scale temporary housing arrangements after natural disasters." *Journal of Computing in Civil Engineering* 23 (2):110-118.
19. Fenner, RA, PM Guthrie, and E Piano. 2007. "Process selection for sanitation systems and wastewater treatment in refugee camps during disaster-relief situations." *Water and Environment Journal* 21 (4):252-264.
20. Ford, George, Yong Han Ahn, and Don Mook Choi. 2014. "Modular Building for Urban Disaster Housing: Case Study of Urban Post-Disaster Housing Prototype in New York." *Fire Science and Engineering* 28.
21. Foster, Harold D, D Harold, and Percy Bysshe Shelley. 1997. "The Ozymandias principles."
22. Fritz, Charles Edward. 1961. *Disaster*: Institute for Defense Analyses, Weapons Systems Evaluation Division.
23. Fritz, Charles E., and Harry B. Williams. "The human being in disasters: A research perspective." *American Academy of Political and Social Sciences* 309, no.1 (1957): 42-51.
24. Félix, Daniel, Jorge M Branco, and Artur Feio. 2013. "Temporary housing after disasters: A state of the art survey." *Habitat International* 40:136-141.
25. Gantes, Charalambos. 1991. "A design methodology for deployable structures." *Massachusetts Institute of Technology*.
26. Gupta, Sundeep K, Astrid Suantio, Alicia Gray, Endang Widyastuti, Neena Jain, Reineke Rolos, Robert M Hoekstra, and Rob Quick. 2007. "Factors associated with E. coli contamination of household drinking water among tsunami and earthquake survivors, Indonesia." *The American journal of tropical medicine and hygiene* 76 (6):1158-1162.

27. Hadar, Ron, and Shmuel Arditi. 2014. Systems and methods to balance solar panels in a multi-panel system. US Patent 8,860,246.
28. Hartkopf, Volker. 1984. "Design Education through Research and Demonstration Projects." Architectural values and world issues: proceedings of the 71st Annual Meeting of the Association of Collegiate Schools of Architecture, 1983.
29. Hartkopf, Volker H, and Charles H Goodspeed. 1979. "Space Enclosures for Emergencies in Developing Countries." *Disasters* 3 (4):443-455.
30. Hosseini, Seyed Ali, and Hasan Habibi Machyani. 2015. "Locating Sites for Temporary Accommodation and Food Storage Silos In The Event of a Crisis in Rasht City-Iran." *J. Mater. Environ. Sci* 6 (10):2825-2835.
31. Jalali, Rita. 2002. "Civil society and the state: Turkey after the earthquake." *Disasters* 26 (2):120-139.
32. Jha, Abhas K. 2009. "Handbook for post-disaster housing and community reconstruction." World Bank: Washington, DC, USA.
33. Karunasena, Gayani, and Raufdeen Rameezdeen. 2010. "Post-disaster housing reconstruction: Comparative study of donor vs owner-driven approaches." *International Journal of Disaster Resilience in the Built Environment*, 1 (2):173-191.
43. Kennedy, Jim, Joseph Ashmore, Elizabeth Babister, and Ilan Kelman. 2008. "The meaning of 'build back better': evidence from post-tsunami Aceh and Sri Lanka." *Journal of contingencies and crisis management* 16 (1):24-36.
35. Kovács, Gyöngyi, and Karen M Spens. 2007. "Humanitarian logistics in disaster relief operations." *International Journal of Physical Distribution & Logistics Management* 37 (2):99-114.
36. Kuaa, HW, and SE Lee. 2002. "Demonstration intelligent building—a methodology for the promotion of total sustainability in the built environment." *Building and Environment* 37 (3):231-240.
37. Lee, Weifeng Victoria. 2006. "Picking up the pieces: transitional shelters for disaster relief in the northern mountainous regions of Pakistan." Massachusetts Institute of Technology.
38. Limoncu, Sevgül, and B Celebioglu. 2006. "Post-disaster sustainable housing system in Turkey." I-Rec 2006 International Conference on Post-Disaster Reconstruction: Meeting Stakeholder Interests.
39. Liu, Qiang, Xuejing Ruan, and Pulong Shi. 2011. "Selection of emergency shelter sites for seismic disasters in mountainous regions: Lessons from the 2008 Wenchuan Ms 8.0 Earthquake, China." *Journal of Asian Earth Sciences* 40 (4):926-934.
40. Lizarralde, Gonzalo, and Cassidy Johnson. 2008. "Myths and realities of prefabrication for post-disaster reconstruction." *Building resilience achieving effective post-disaster reconstruction i-Rec*.

41. Mata, Tomas. "Progressive housing: Reconstruction after the 2001 earthquake in El Salvador." *Building Back Better*:285.
42. Meisl, Christopher S, Sahar Safaie, Kenneth J Elwood, Rishi Gupta, and Reza Kowsari. 2006. "Housing reconstruction in northern Sumatra after the December 2004 great Sumatra earthquake and tsunami." *Earthquake Spectra* 22 (S3):777-802.
43. Misra, RK, Jishiv H Patel, and VR Baxi. 2010. "Reuse potential of laundry greywater for irrigation based on growth, water and nutrient use of tomato." *Journal of Hydrology* 386 (1-4):95-102.
44. Noji, Eric K. 1996. *The public health consequences of disasters*: Oxford University Press.
45. Noji, Eric K. 2005. "Public health issues in disasters." *Critical care medicine* 33 (1):S29-S33.
46. Oliver-Smith, Anthony. 1996. "Anthropological research on hazards and disasters." *Annual review of anthropology* 25 (1):303-328.
47. Owens, Patricia J, Anthony Forgione, and Susan Briggs. 2005. "Challenges of international disaster relief: use of a deployable rapid assembly shelter and surgical hospital." *Journal of Emergency Nursing* 3 (1):11-16.
48. Oxfam, GB. 2005. *Transitional settlement: displaced populations*: Oxfam.
49. Pérez-Sales, Pau, Priscilla Cervellon, Carmelo Vazquez, Diana Vidales, and Mauricio Gaborit. 2005. "Post-traumatic factors and resilience: the role of shelter management and survivors' attitudes after the earthquakes in El Salvador (2001)." *Journal of Community & Applied Social Psychology* 15 (5):368-382.
50. Quarantelli, Enrico L. 1995. "Patterns of sheltering and housing in US disasters." *Disaster prevention and management: an international journal* 4 (3):43-53.
51. Qazi, Farhan. "Green technology for disaster relief and remote areas." (2014): 121st ASEE Annual Conference & Exposition. Paper ID: 10192.
52. Schilderman, Theo. 2004. "Adapting traditional shelter for disaster mitigation and reconstruction: experiences with community-based approaches." *Building Research & Information* 32 (5):414-426.
53. Song, Yiming, Nalanie Mithraratne, and Hong Zhang. 2016. "Life-time performance of post-disaster temporary housing: A case study in Nanjing." *Energy and Buildings* 128:394-404.
54. Stevenson, Anne, and Rebecca Sutton. 2011. "There's No Place Like a Refugee Camp? Urban Planning and Participation in the Camp Context." *Refuge: Canada's Journal on Refugees* 28 (1).
55. Tatham, Peter, and Luke Houghton. 2011. "The wicked problem of humanitarian logistics and disaster relief aid." *Journal of Humanitarian Logistics and Supply Chain Management* 1 (1):15-31.

56. Tierney, Kathleen. 2012. "Disaster governance: Social, political, and economic dimensions." *Annual Review of Environment and Resources* 37:341-363.
57. Tierney, Kathleen J. 2007. "From the margins to the mainstream? Disaster research at the crossroads." *Annual Review of Sociology* 33.
58. Tierney, Kathleen, and Anthony Oliver-Smith. 2012. "Social Dimensions of Disaster Recovery." *International Journal of Mass Emergencies & Disasters* 30 (2).
59. Tress, Bärbel, and Gunther Tress. 2001. "Capitalising on multiplicity: a transdisciplinary systems approach to landscape research." *Landscape and urban planning* 57 (3-4):143-157.
60. Wallemacq, P, and R Below. 2015. *The human cost of natural disasters: A global perspective*. Brussels, Belgium: Centre for Research on the Epidemiology of Disasters.
61. Yee, Maria. "Engineered bamboo furniture with mortise and tenon joints." (2006).
62. Zanjani, Siavash Sefidgar. 2009. "A New Typology for Disaster Relief." Carleton University Ottawa.
63. Zhang, Jia Liang, Yong Fei Du, Zhi Min Yan, and Yu Shun Li. 2012. "Study on Bonding Properties of Bamboo-Steel Interface under Static Load." *Applied Mechanics and Materials*.
64. Zook, Matthew, Mark Graham, Taylor Shelton, and Sean Gorman. 2010. "Volunteered geographic information and crowdsourcing disaster relief: a case study of the Haitian earthquake." *World Medical & Health Policy* 2 (2):7-33.
- 65.(A) UNHCR Emergency Handbook-WASH in camps, 2015, online:
<https://emergency.unhcr.org>
- 66.(B) UN World Conference on Disaster Risk Reduction Issue Brief- "Reconstructing after disasters: Build back better Ministerial Roundtable," March 18, 2015, online:
<http://www.wcdrr.org/uploads/Reconstructing-after-disasters-Build-back-better.pdf>
- 67.(C) "Refugee Camps: Unintentional Landscapes?" Watkins Design Associates, 2018, online:
http://watkinsdesignassociates.co.uk/refugee-camps-unintentional-landscapes/#_ftn8
- 68.(D) "Nine Massive Refugee Camps that are Home to Nearly 1.5 Million People," Andrew Tarantola, Gizmodo, September 13, 2013, online:
<http://gizmodo.com/9-massive-refugee-camps-that-are-home-to-nearly-1-5-mil-1252638977>
- 69.(E) "Contributing to a global post-2015 disaster risk reduction framework," Ecojesuit, 28 February 2015, online:
<http://www.ecojesuit.com/contributing-to-a-global-post-2015-disaster-risk-reduction-framework/7687/>

70.(D) The Sphere Project Humanitarian Charter and Minimum Standards in Humanitarian Response, Shelter and Settlement standard 5: Environmental impact, 2011, online:
<http://www.spherehandbook.org/en/shelter-and-settlement-standard-5-environmental-impact/>

71.(E) UNHCR Emergency Handbook 2015, online:
<https://emergency.unhcr.org>

72.(F) "Top 10 "Alternative" Construction Methods," Dean Dalvit, November 30, 2017, online:
<http://evstudio.com/top-10-alternative-construction-methods/>

73.(G) "Jordan: World's largest solar park for refugee camp switched on," Dunya Web News, November 15, 2017, online:
<http://dunyanews.tv/en/World/414519->

74.(H) "Jordan switches on world's largest solar plant in refugee camp," Reuters Staff, November 13, 2017, online:
<https://www.reuters.com/article/us-jordan-solar-zaatari/jordan-switches-on-worlds-largest-solar-plant-in-refugee-camp-idUSKBN1DD22N>

75.(I) The Architecture of Simon Vélez pioneers "new ways of using giant bamboo," Marcus Fairs, Dezeen, July 21, 2014, online:
<http://www.dezeen.com/2014/07/21/simon-velez-giant-bamboo-architecture-domaine-de-boisbuchtet-interview/>

76.(J) UNHCR Emergency Handbook-WASH in camps, 2015, online:
<https://emergency.unhcr.org/entry/39930/wash-in-camps>

77.(K) Global Strategy for Settlement and Shelter-UNHCR Strategy 2014-2018, online
<http://www.unhcr.org/530f13aa9.pdf>

78.(L) UNHCR Emergency Handbook-WASH in camps, 2015, online:
<https://emergency.unhcr.org/entry/39930/wash-in-camps>

79.(M) Transitional settlement: displaced populations GB Oxfam, 2005,books.google.com, online:
<https://www.sheltercluster.org/sites/default/files/docs/Transitional%20Settlement%20-%20Displaced%20Populations.pdf>

80.(N) The Sphere Handbook, online:
<http://www.sphereproject.org>

81. CRED, online:
<http://www.cred.be>

82. EM-DAT, online:
<http://www.emdat.be>

83. UN/OCHA/ESB 2006, online:
http://interactive.unocha.org/publication/2006_annualreport/html/acronyms.html

84. IFRC/RCS, 2013, online:
<http://www.ifrc.org/en/publications-and-reports/annual-report-2013/>
85. CILT, 2006, online:
http://ec.europa.eu/dgs/education_culture/repository/languages/policy/strategic-framework/documents/elan_en.pdf
86. International Organization for Migration, 2012, online:
<https://www.iom.int>
87. Sri Lanka Institute of Policy of Studies, 2006, online:
<http://www.ips.lk>
88. International Organization for Migration, 2012, online:
<https://www.iom.int>
89. NOAA, online:
<http://www.noaa.gov>
90. CLC Thai Method Engineered Bamboo preparation, online:
<http://www.bamboo-earth-architecture-construction.com/bamboo-treatment/>
- 91.(O)The Sphere Handbook, online:
<http://www.sphereproject.org>
- 92.(P) China National Bamboo Research Center (CBRC), online:
<http://www.eco-web.com/reg/00433.html>

CITATIONS

1. Davidson, Colin, Gonzalo Lizarralde, and Cassidy Johnson. "Myths and realities of prefabrication for post-disaster reconstruction." In 4th International I-Rec Conference 2008 Building Resilience: achieving effective post-disaster reconstruction. 2008.
2. Cornwall, Andrea. "Making spaces, changing places: situating participation in development." (2002).
3. Davidson, Colin, Gonzalo Lizarralde, and Cassidy Johnson. "Myths and realities of prefabrication for post-disaster reconstruction." In 4th International I-Rec Conference 2008 Building Resilience: achieving effective post-disaster reconstruction. 2008.
4. Kovács, Gyöngyi, and Karen M Spens. 2007. "Humanitarian logistics in disaster relief operations." International Journal of Physical Distribution & Logistics Management 37 (2):99-114.
5. Hadar, Ron, and Shmuel Arditi. 2014. Systems and methods to balance solar panels in a multi-panel system. US Patent 8,860,246.

6. Bashawri, Abdulrahman, Stephen Garrity, and Krisen Moodley. 2014. "An overview of the design of disaster relief shelters." *Procedia Economics and Finance* 18:924-931
7. Karunasena, Gayani, and Raufdeen Rameezdeen. 2010. "Post-disaster housing reconstruction: Comparative study of donor vs owner-driven approaches." *International Journal of Disaster Resilience in the Built Environment*, 1 (2):173-191.
- 8.. Ahmed, Iftekhar. 2011. "An overview of post-disaster permanent housing reconstruction in developing countries." *International Journal of Disaster Resilience in the Built Environment* 2 (2):148-164.
9. Tierney, Kathleen J. 2007. "From the margins to the mainstream? Disaster research at the crossroads." *Annual Review of Sociology* 33.
10. Oliver-Smith, Anthony. 1996. "Anthropological research on hazards and disasters." *Annual review of anthropology* 25 (1):303-328.
11. Schilderman, Theo. 2004. "Adapting traditional shelter for disaster mitigation and reconstruction: experiences with community-based approaches." *Building Research & Information* 32 (5):414-426.
12. Félix, Daniel, Jorge M Branco, and Artur Feio. 2013. "Temporary housing after disasters: A state of the art survey." *Habitat International* 40:136-141.
14. Quarantelli, Enrico L. 1995. "Patterns of sheltering and housing in US disasters." *Disaster prevention and management: an international journal* 4 (3):43-53.
15. Bradford, NM, and R Sen. 2005. "Multiparameter assessment guide for emergency shelters: Disaster relief applications." *Journal of performance of constructed facilities* 19 (2):108-116.
16. Chang, Yan, Suzanne Wilkinson, Erica Seville, and Regan Potangaroa. 2010. "Resourcing for a resilient post-disaster reconstruction environment." *International Journal of Disaster Resilience in the Built Environment* 1 (1):65-83.
17. Wallemacq, P, and R Below. 2015. *The human cost of natural disasters: A global perspective*. Brussels, Belgium: Centre for Research on the Epidemiology of Disasters.
18. Kuaa, HW, and SE Lee. 2002. "Demonstration intelligent building—a methodology for the promotion of total sustainability in the built environment." *Building and Environment* 37 (3):231-240.
19. Jha, Abhas K. 2009. *Handbook for post-disaster housing and community reconstruction*. World Bank: Washington, DC, USA.
20. Brown, Charlotte, Mark Milke, and Erica Seville. 2011. "Disaster waste management: A review article." *Waste management* 31 (6):1085-1098.
21. Noji, Eric K. 2005. "Public health issues in disasters." *Critical care medicine* 33 (1):S29-S33.

22. Fenner, RA, PM Guthrie, and E Piano. 2007. "Process selection for sanitation systems and wastewater treatment in refugee camps during disaster-relief situations." *Water and Environment Journal* 21 (4):252-264.
23. Mata, Tomas. "Progressive housing: Reconstruction after the 2001 earthquake in El Salvador." *Building Back Better*:285.
24. Bhave, Swati Y, Panna Choudhury, Harish K Pemde, YC Mathur, and IAP Task Force on Child at Risk. 2005. "IAP workshop on disaster management practices: recommendations and IAP plan of action." *Indian Pediatr* 42 (9):887-903.
25. Fritz, Charles Edward. 1961. *Disaster*: Institute for Defense Analyses, Weapons Systems Evaluation Division.
26. Pérez-Sales, Pau, Priscilla Cervellon, Carmelo Vazquez, Diana Vidales, and Mauricio Gaborit. 2005. "Post-traumatic factors and resilience: the role of shelter management and survivors' attitudes after the earthquakes in El Salvador (2001)." *Journal of Community & Applied Social Psychology* 15 (5):368-382.
27. Qazi, Farhan. "Green technology for disaster relief and remote areas." (2014): 121st ASEE Annual Conference & Exposition. Paper ID: 10192.
28. Berger, Christina. "Biochar and activated carbon filters for greywater treatment." (2012).
29. Yee, Maria. "Engineered bamboo furniture with mortise and tenon joints." (2006).

Webpages

- 28.(B) UN World Conference on Disaster Risk Reduction Issue Brief- "Reconstructing after disasters: Build back better Ministerial Roundtable," March 18, 2015, online:
<http://www.wcdrr.org/uploads/Reconstructing-after-disasters-Build-back-better.pdf>
- 29.(C) "Refugee Camps: Unintentional Landscapes?" Watkins Design Associates, 2018, online:
http://watkinsdesignassociates.co.uk/refugee-camps-unintentional-landscapes/#_ftn8
- 30.(D) "9 Massive Refugee Camps that are Home to Nearly 1.5 Million People," Andrew Tarantola, Gizmodo, September 13, 2013, online:
<http://gizmodo.com/9-massive-refugee-camps-that-are-home-to-nearly-1-5-mil-1252638977>
- 69.(E) "Contributing to a global post-2015 disaster risk reduction framework," Ecojesuit, 28 February 2015, online:
<http://www.ecojesuit.com/contributing-to-a-global-post-2015-disaster-risk-reduction-framework/7687/>
- 70.(D) The Sphere Project Humanitarian Charter and Minimum Standards in Humanitarian Response, Shelter and Settlement standard 5: Environmental impact, 2011, online:
<http://www.spherehandbook.org/en/shelter-and-settlement-standard-5-environmental-impact/>
- 32.(E) UNHCR Emergency Handbook 2015, online:
<https://emergency.unhcr.org>

33.(F) "Top 10 "Alternative" Construction Methods," Dean Dalvit, November 30, 2017, online:
<http://evstudio.com/top-10-alternative-construction-methods/>

73.(G) "Jordan: World's largest solar park for refugee camp switched on," Dunya Web News, November 15, 2017, online:
<http://dunyanews.tv/en/World/414519->

74.(H) "Jordan switches on world's largest solar plant in refugee camp," Reuters Staff, November 13, 2017, online:
<https://www.reuters.com/article/us-jordan-solar-zaatari/jordan-switches-on-worlds-largest-solar-plant-in-refugee-camp-idUSKBN1DD22N>

75.(I) The Architecture of Simon Vélez pioneers "new ways of using giant bamboo," Marcus Fairs, Dezeen, July 21, 2014, online:
<http://www.dezeen.com/2014/07/21/simon-velez-giant-bamboo-architecture-domaine-de-boisbuchtet-interview/>

76.(J) UNHCR Emergency Handbook-WASH in camps, 2015, online:
<https://emergency.unhcr.org/entry/39930/wash-in-camps>

77.(K) Global Strategy for Settlement and Shelter-UNHCR Strategy 2014-2018, online
<http://www.unhcr.org/530f13aa9.pdf>

34.(L) UNHCR Emergency Handbook-WASH in camps, 2015, online:
<https://emergency.unhcr.org/entry/39930/wash-in-camps>

35.(M) Transitional settlement: displaced populations GB Oxfam, 2005,books.google.com, online:
<https://www.sheltercluster.org/sites/default/files/docs/Transitional%20Settlement%20-%20Displaced%20Populations.pdf>

36.(N) The Sphere Handbook, online:
<http://www.sphereproject.org>

37. EM-DAT, online:
<http://www.emdat.be>

38. IFRC/RCS, 2013, online:
<http://www.ifrc.org/en/publications-and-reports/annual-report-2013/>

39. CILT, 2006, online:
http://ec.europa.eu/dgs/education_culture/repository/languages/policy/strategic-framework/documents/elan_en.pdf

40. CLC Thai Method Engineered Bamboo preparation, online:
<https://www.bamboo-earth-architecture-construction.com/bamboo-treatment/>

41.(O)The Sphere Handbook, online:

<http://www.sphereproject.org>

42. CRED, online:
<http://www.cred.be>

43.(P) China National Bamboo Research Center (CBRC), online:
<http://www.eco-web.com/reg/00433.html>

44.(A) UNHCR Emergency Handbook-WASH in camps, 2015, online:
<https://emergency.unhcr.org>

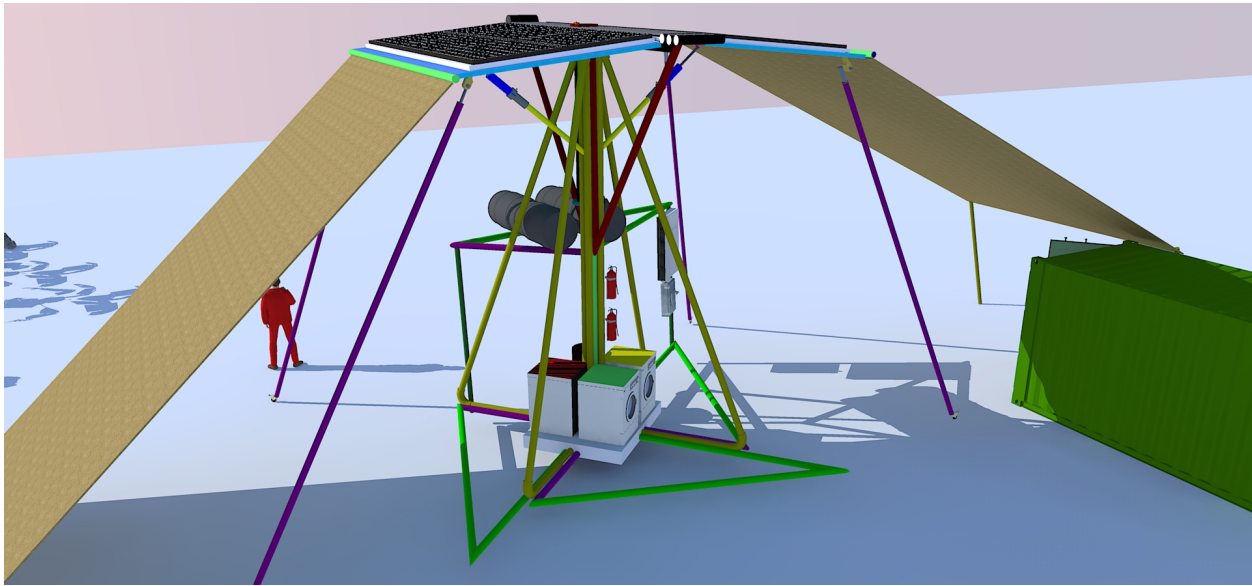

© Albert K. Muhleman

Every project makes for dramatic times in life. Friends and family are often tested sorely by the writing student. I am thankful to have such fine folks to help up this arduous mountain.

I want to heartily thank these fine folks who helped me achieve my dream of completing this assignment:

Peter Kumble
Phil Gorman
John Woolard
Tom Vinson
Milo Jones
Bijay Quonmey
Alex Neuhaussen
Pavlo Max
Margaret T. Dunn
Hartwell Gary
Fitzhugh Gary
Martha Taylor
Sandra Baylor
And Jake!