

BRNO UNIVERSITY OF TECHNOLOGY

FACULTY OF MECHANICAL ENGINEERING

INSTITUTE OF SOLID MECHANICS, MECHATRONICS AND
BIOMECHANICS

Ing. Lukáš Březina

OPTIMIZATION OF A PARALLEL MECHANISM
DESIGN WITH RESPECT TO A STEWART
PLATFORM CONTROL DESIGN

OPTIMALIZACE NÁVRHU PARALELNÍHO MECHANISMU VZHLEDEM
K ŘÍZENÍ STEWARTOVY PLATFORMY

Shortened Ph.D. Thesis

Supervisor: prof. Ing. Eduard Malenovský, DrSc.

Contents

1. Introduction	3
2. State of the art	4
2.1 Kinematics of parallel manipulators	4
2.2 Dynamics of the parallel manipulators.....	5
2.3 Notes to the control of parallel manipulators.....	5
2.4 Notes to modeling of systems with uncertainties.....	6
2.5 Summary and the problem description.....	6
3. Goals of the work	6
4. Proposed approach	7
5. The device description	8
6.1 The linear actuator with gearings	8
5.2 The Stewart platform.....	8
6. SimMechanics modeling of the device	9
6.1 Stewart platform and the linear actuator modeling	9
6.2 DC motor modeling.....	10
7. Linearization	10
8. Stewart platform control design based on the SimMechanics model	11
9. Uncertain modeling	13
10.1 Model of the DC motor with uncertain parameters.....	13
10.2 Stewart platform model with uncertain parameters	14
10. The model verification	15
11. Results	18
References	20

1. Introduction

The model based control is very interesting possibility not even for robotics but also for other technical disciplines. Obtaining of high accuracy control is nowadays often solved by implementing of the model to the control system. Model of the system built into the control system monitors data obtained from the sensors and actuators. Implementation of such controllers is nowadays possible thanks to the computational power of modern computers [20].

The models are differentiated according to the structure and prediction quality. Basic concepts are mainly [43]:

- simplified models, mainly linear,
- fenomenologic equation,
- neural networks,
- decision trees,
- look- up tables.

From the presented point of view arise following requirements on the optimal model of the system and on the optimization of the design with the model support:

- evaluation in the shortest possible time,
- possibility of the processing of the deviations from the reality,
- (simple) investigation of the system controllability
- (simple) investigation if it is possible to use the model for estimation of selected parameters (especially in cases of parameters which is difficult or impossible to measure)

The proposed work is then focused on such an optimal modeling of a parallel robot generally known as Stewart platform.

The construction of general parallel robot basically stands on a closed kinematic chain. Therefore a load carried by the end-effector is divided between particular kinematic chains linking the effector to the base. Such a construction of a manipulator leads to very high stiffness of the device and high load/robot mass ratio, possibility of lighter construction, thus better dynamics. Other advantages may be higher positioning accuracy, using same parts for all links or possibility of mounting of the actuators to the base of the device. These are some of advantages when comparing parallel manipulators with serial ones (open kinematic chain). The main disadvantage of a parallel manipulator construction is then quite small volume of the workspace limited by singular areas and usually quite complicated kinematics and dynamics.

The history of the first industrially used parallel manipulators started in a year 1955 when Gough [25] constructed the first prototype of a six degrees of freedom parallel manipulator for tire wear testing (used in Dunlop Tires till year 2000). The machine consisted of a platform (end-effector) and six extendable links which connected the platform to the base frame. The very similar construction was used approximately 10 years later by Cappel and also by Stewart for a flight simulator construction. From then parallel manipulators have been used in many other sectors of industry where their advantages as high stiffness, precise positioning, high load/robot mass ratio, may be used. Let's name for all fast pick and place applications (ABB FlexPicker, Fanuc M-1iA), machining robots (Metrom P-800), positioning of heavy antennas, microscopes (usually hexapods in general), spot welding (Fanuc F-200iB), etc.

The parallel robots are in general suitable for applications where high positioning accuracy is more important than volume of the workspace, for applications where

manipulation with heavy loads in small workspace (simulators, antenna manipulation, ...) is needed or fast pick and place applications.

The presented work is based on needs of projects MSM0021630518 "Simulation modeling of mechatronic systems" and MŠMT KONTAKT 1P05ME789 "Simulation of mechanical function of selected elements of human body" which had been solved at BUT recently. One of aims of named projects was to construct a Stewart platform. The device is planned to use for biomechanical experiments such as joints endoprosthesis (hip, knee) wear testing or for spinal elements testing. Such an usage leads to specific requirements in construction and control. Hence it was necessary to build a model of the system dynamics and kinematics according to the engineering design at first. The model was built in such a way to satisfy requirements for a control design and for testing of the designed control as well as for testing of the device behavior. In other words the model had to be sufficiently precise in the system description but on the other hand it had to be modest in computational time consumption.

Building a model which is suitable for simulation and optimal for a control design at the same time might be quite complicated task – especially in case of dynamic model containing high number of interacting bodies within a spatial closed kinematics chain with six degrees of freedom of the end-effector.

The proposed approach is based on modeling of dynamics within a modern simulation tools with possibility of linearization. The modeling inaccuracies are compensated by defining of uncertain parameters in the model. The obtained structure of the model is in a state-space form which is suitable either for simulations or for a control design.

Let's note that proposed approach demonstrated on the Stewart platform is highly versatile and easily applicable to wide range of systems and processes. The method reflects actual industry needs leading to increase of a product quality, preciseness, production capacity, dependability, system economy and decrease of the environment damage. The simulation and control of the system significantly influences all of these needs.

2.State of the art

2.1 Kinematics of parallel manipulators

Modeling of a parallel mechanism kinematics may be solved as direct and inverse task. The inverse kinematics is characteristic with known position and orientation of the end-effector and joint coordinates are solved. Solving the inverse kinematics is necessary for the position control of a manipulator. There are generally two approaches to the solving of the inverse kinematics – analytical based on work with transformation matrices [24], [37] and geometrical [39].

The opposite is the direct kinematics where the joint coordinates are known and position and orientation of the end-effector is solved [1], [16]. Solving of the direct kinematics is much more complicated than inverse in case of parallel manipulators. This is in opposite with kinematics of serial manipulators. The method is usually based on a numerical iterative principle [40], [37], use of genetic algorithm [2] or for example using of extra sensors [37]. Very interesting method based on solving the determinant of Sylvester's matrix suitable for a real-time use was proposed in [32].

2.2 Dynamics of parallel manipulators

The model of system dynamics is usually needed for a control of devices which move fast or heavily loaded devices, i.e. of devices where their dynamics effects strongly affect the system behavior. The one of problems of dynamics modeling is that not all of the parameters are known precisely even with use of on-line estimation methods. The other problem is the computational time intensity.

There are often used common methods for dynamics of machines modeling in case of parallel manipulators. These are Newton-Euler principle [10], [14], [15], [17], principle of virtual works [9], [13], [23], [25], [34], Lagrange's equations [15], [63] and the Hamilton principle [52]. There are sometimes used combinations of methods, e.g. combination of Lagrange's equations and Newton-Euler principle in [38].

Description of a parallel manipulator full dynamics via one of these methods is usually quite complicated and numerical solution of the obtained model is too much time consuming. Such a dynamics model is inappropriate for a control design. Therefore simplifying suggestions shortening the computational time are often made.

One of such simplifications might be neglecting of inertia moments of the robot links and at the same time assuming their masses at their ends [13], [44]. This approach was successfully applied on Delta robot (the robot structure is using for example ABB in their FlexPicker). Although the approach was successfully implemented with Delta robot, neglecting of links inertia moments in case of Stewart platform leads to insufficient positioning accuracy of the controller [22]. Another approach is presented in [31] where the simplification is based on small workspace of the Stewart platform. The configuration-dependent coefficient matrices of the dynamic equations are approximated to be constant. The introduced modeling error is compensated by the H-infinity controller. Other publications dealing with the simplification of a model dynamics are for instance [12], [21], [36], [45], [49], [51].

Very interesting possibilities of dynamics modeling are nowadays offered by numerous simulation softwares – Adams, Matlab – SimMechanics, Chrono R3D, Inventor, SolidWorks, etc. The advantage is that such environments allow user to work with the model in much more complex way (build a model, design a controller, connecting of models, etc.). This might be very efficient tool for “rapid prototyping” or classical mechatronic approach where it is taken into account that different phases of a product design are mutually connected and strongly influencing each other. Very inspiring example from the point of view of parallel manipulators is used in Matlab demos where a simple model of a Stewart platform was built, linearized and consequently a PID controller was designed [48]. However the model is in its simplest form and contains no uncertainties.

2.3 Notes to the control of parallel manipulators

Control of parallel manipulators might be quite complicated especially in cases where the dynamics model is needed. Most common is the position control [30], [31], [46] but in some cases also a torque control is used [53]. Possibilities of simplified dynamics models are studied recently (see above). Interesting possibility of H-infinity controller application for compensation of inaccuracies caused by a model simplification was studied in [31]. The possibilities of parallel manipulators control are also described in [3], [8], [18], [19], [35], [36], [49], [51], [52].

2.4 Notes to modeling of systems with uncertainties

The most of models describing dynamics of systems are more or less inaccurate. It may be mostly caused by mentioned simplifications, neglecting of some factors influencing the dynamics or general modeling inaccuracy. It is possible to describe these inaccuracies by defining an uncertainty of the whole model or of the chosen parameters. The model containing the uncertainty description is then applicable for design of a robust controller. Such a controller is then able to control all systems within a given uncertainty range.

The uncertain modeling is very versatile and easily applicable on wide spectrum of human activity. The standard approach to modeling of uncertain mechanical systems for a robust control purposes is described in [26] or [27].

2.5 Summary and the problem description

The inverse kinematics of the parallel manipulators has been intensively studied for several decades and its solution is no more a problem. On the other hand the direct kinematics is for its strong nonlinearity still quite challenging task especially in cases where a real-time application is considered. Very promising solution of a Stewart platform real-time direct kinematics was proposed in [32].

The modeling of dynamics of parallel manipulators is mostly solved by classical methods of dynamics but often also by a simulation modeling. The problem is typically insufficient computational efficiency for a real-time use. This is often treated by simplifying suggestions where some of the system parameters are neglected or the model is simplified [31].

The problem of simplifications or approximations of the dynamic models introduced in order to increase the computational efficiency is following. It has to be very carefully considered for every individual type of a mechanism which simplifications it is possible to make. Some of simplifications can be made for some type of a mechanism but for other not – the method is not versatile.

The other problem is that a model of dynamics usually contains many inaccuracies. The problem is getting worse by introducing of mentioned simplifications and approximations.

Modeling of systems with uncertainties is nowadays used in many even nontechnical applications [28], [33], [47] for description of a model inaccuracy. But in case of modeling of parallel robots it is very rare.

3. Goals of the work

The main goal of the work is to propose and verify a methodology for design of dynamic models of parallel manipulators optimal for a control design. Such an optimal model must satisfy following conditions:

- evaluation in the shortest possible time,
- possibility of the processing of the deviations from the reality,
- (simple) investigation of the system controllability
- (simple) investigation if it is possible to use the model for estimation of selected parameters (especially in cases of parameters which is difficult or impossible to measure)

Let's note that actual needs of the modern industry are taken into account, thus it is expected use of more advanced controllers than just a simple PID and use of modern control techniques.

The method should be also universal and applicable on other mechatronic systems such as machining tools, robotics in general, engines and other.

Building of such an optimal model satisfying the above requirements will be illustrated on the Stewart platform developed at BUT which has intended use in biomechanical applications [6], [7].

Thus the model will be optimized for investigation of possibility of control design techniques application, description of modeling inaccuracies and for computational modesty.

Sectional goals are following:

- Analyze present methods of modeling of parallel mechanism
- Design an appropriate method for a parallel robot modeling
- Build a model describing kinematics and dynamics of the Stewart platform
- Optimize the model for the control design purposes
- Verify the model with the real device
- Formulation of conclusions

4. Proposed approach

The proposed approach is based on mentioned advantages of the linear model representation.

The model itself utilizes advantages of Matlab SimMechanics simulation environment which offers many tools for modeling of kinematics and dynamics of mechanisms as well as the possibility of linearization. The simulation environment is for its good connectivity with Simulink suitable for simulations of a control and for the model and data manipulation.

There are also derived standard equations of the inverse kinematics for the simulation and control purposes.

The linear model obtained from SimMechanics guarantees simplicity, computational efficiency and wide spectrum of methods for the manipulation with the model and for a model based controller design.

Inaccuracies of the model caused by the linearization, neglected dynamics or improperly defined parameters are then described by definition of uncertainties for the individual model parameters.

The uncertain modeling is used for describing of inaccuracies caused by shifting of the linearization operating points of the Stewart platform and by modeling inaccuracy of selected parameters of the Stewart platform and the DC motor model.

The method for modeling of uncertainties of the DC motor is based on the standard parametric uncertainty definition. It is then proposed a method for defining of individual parameters of the model state matrices as uncertain. This is profitable especially in cases of higher order models. The method is used in case of the Stewart platform uncertainty modeling.

The uncertain model may be with advantage used for a “worst case scenario” analysis and for a robust control design. The uncertain model is linear thus keeping all advantages of the linear representation.

5. The device description

5.1 The linear actuator with gearings

The Stewart platform consists of six linear actuators (links) which manipulate with top plate of the platform. The change of the actuator (Fig. 5.1, 5.2) length leads to the change of the platform position and orientation. The links lengths needed to obtain desired position and orientation of the platform are then easily evaluated with the knowledge of the inverse kinematics.

The choice of joints within the linear actuator itself is subjected to the overall movement of the platform which has to be fully three dimensional, i.e. with six degrees of freedom. Thus the upper joint connecting the actuator to the platform is spherical (three rotational degrees of freedom) and the lower joint connecting the actuator to the base is universal (two rotational degrees of freedom). With the middle translational joint (ball screw in our case) connecting together upper and lower part of the linear actuator.

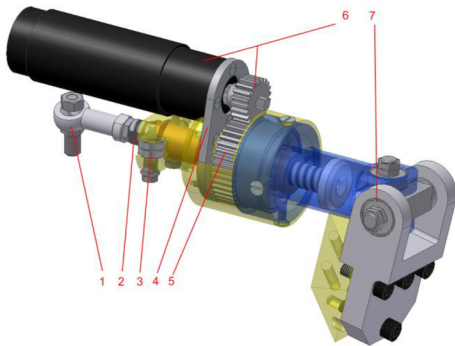

Fig.5.1 Joints of the linear actuator (by Houška, P.)

1 spherical joint, 2 ball screw, 3 ball screw guidance, 4 motor attachment plate, 5 screw nut, 6 gears, 7 universal joint

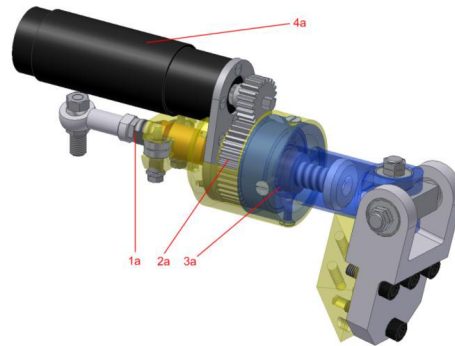

Fig.5.2 Bodies of the linear actuator (by Houška, P.)

1a ball screw, 2a screw nut, 3a lower part of the link, 4a DC motor

Technical parameters are following. The used DC motor is Maxon RE 35 (90 W), single stage planetary gearbox Maxon GP 32 C with gear ratio 4.8:1, the gear ratio of the spur gearing is 41:21, the screw-thread is 4 mm. The maximal length of the single linear actuator is 188 mm, the minimal length is 159 mm.

5.2 The Stewart platform

The basic geometry of the device (Fig. 5.3, 5.4) is defined by position of the base and platform connection points for linear actuators attachment, Fig 6.5, 6.6. The basic geometry of the Stewart platform is amongst others described in [39].

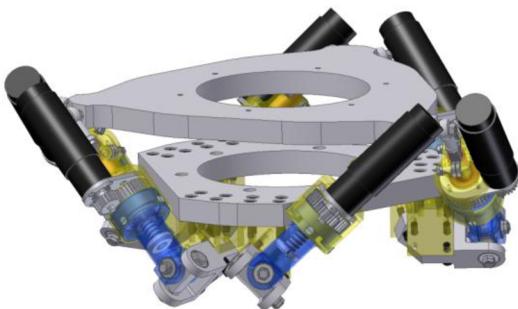

Fig. 5.3 The designed Stewart platform – 3D model (by Houška, P.)



Fig. 5.4 The designed Stewart platform – reality (by Houška, P.)

6. SimMechanics modeling of the device

6.1 Stewart platform and the linear actuator modeling

The model of the linear actuator with gearings is then built with use of SimMechanics joints and bodies libraries, Fig. 6.1, Fig. 6.2.

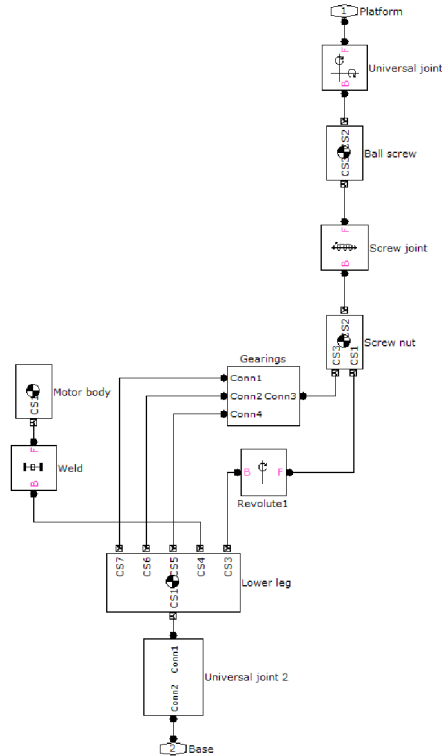

Fig. 6.1 SimMechanics model of the Stewart platform linear actuator

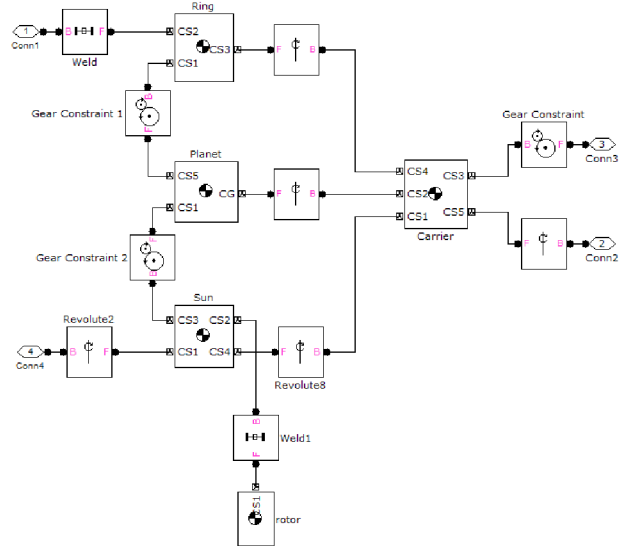

Fig. 6.2 SimMechanics model of gearings (planetary gearbox and spur gearing)

The Stewart platform model is then built from six linear actuators subsystems and the platform body [4], Fig. 6.3.

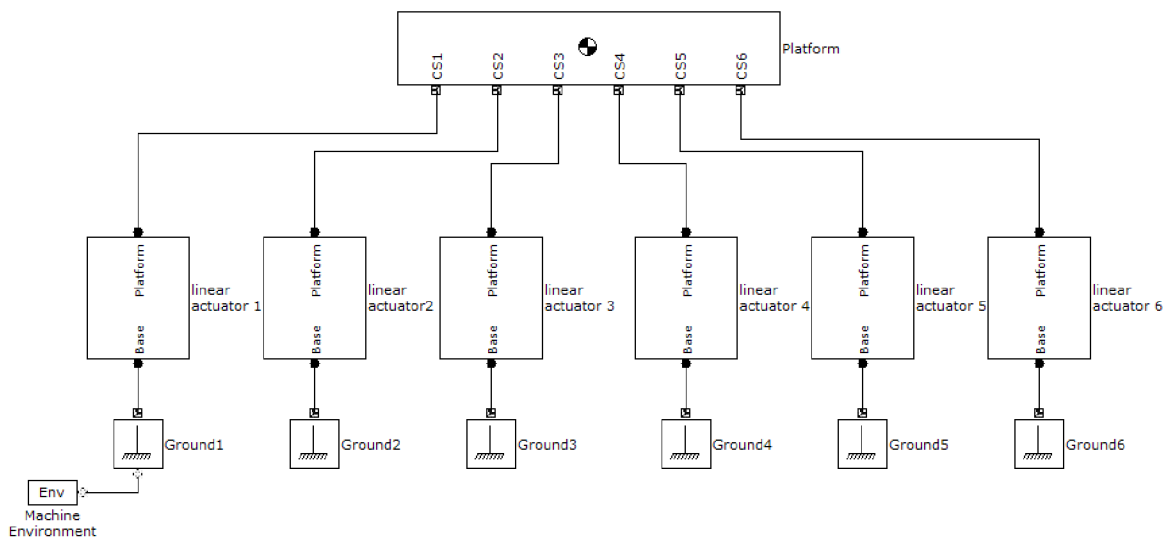

Fig. 6.3 SimMechanics model of the Stewart platform with linear actuator subsystems. Platform connection points correspond with CS1, ..., CS6 and the base points with Ground1, ..., Ground6

Inputs and outputs of the Stewart platform SimMechanics model are given by supposed control requirements. The basic idea is to control the position and orientation of the platform by DC motors shaft torques which are produced by the motors input voltage. The position and orientation of the platform is given by the links lengths which are described by the inverse kinematics. The changes of the links lengths are then given by rotation of the screw nut which moves the ball screw.

The inputs/outputs of the Stewart platform mechanical model are on the most basic layer following: the inputs are torques $\mathbf{m} = (M_1, \dots, M_6)^T$ produced by DC motors and outputs are angular displacements of the screw nuts $\mathbf{q} = (\varphi_1, \dots, \varphi_6)$ and their angular velocities $\dot{\mathbf{q}} = (\dot{\varphi}_1, \dots, \dot{\varphi}_6)$.

Adding chosen inputs and outputs to the SimMechanics model is provided by connecting blocks of sensors and actuators. The torque actuator is added to the input element of the planetary gearbox in case of the DC motor torques and the joint sensor is added to the revolute joint representing rotational movement of the screw nut.

6.2 DC motor modeling

The model contained two kinds of subsystems till now. It was the linear actuator subsystem and the gearings subsystem. The new subsystem will represent the DC motor Maxon RE35.

The RE 35 (catalogue number 273754) has power of 90W, its nominal torque is 0,0977Nm, nominal voltage 42V, nominal speed is 6770rpm and no load speed 7530rpm. The unloaded DC motor model is based on well known description:

$$\begin{aligned} \frac{di}{dt} &= -\frac{R}{L}i - \frac{K_b}{L}\omega + \frac{1}{L}u \\ \frac{d\omega}{dt} &= -\frac{1}{J}K_f\omega + \frac{1}{J}K_m i \end{aligned} \quad (6.1)$$

The second equation is then transformed by $J \frac{d\omega}{dt} = M$ in order to obtain a shaft torque as the system output into

$$M = -K_f\omega + K_m i, \quad (6.2)$$

where M is the motor shaft torque, K_M is the torque constant, J is the rotor inertia, K_f is the linear approximation of the viscous friction, i is the momentary value of the electrical current, ω is the momentary angular velocity of the shaft, K_b is the voltage constant, R is the terminal resistance, L is the terminal inductance and finally u is the momentary driving voltage.

7. Linearization of the Stewart platform model

The linearization is performed for the pure mechanical model of the Stewart platform without DC motors. There was used a Control and estimation manager in Matlab for the linearization purposes.

The comparison between the linear and the nonlinear model was performed for the same input torque with amplitude 0,1Nm and frequency 2Hz for all of the linear actuators, Fig. 7.1. Thus the movement of the platform is just in the z-axis. The maximal z-axis distance between the centers of gravity of the base and the platform allowed by construction of the

device is 0,1462m. The maximal distance reached during the simulation was 0,1407m – the platform was very close to its maximal workspace borders, Fig. 7.2.

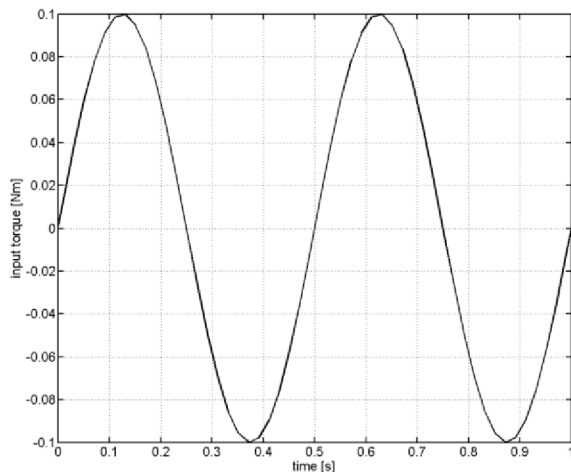

Fig. 7.1 Input torque of all linear actuators for both linear and nonlinear model

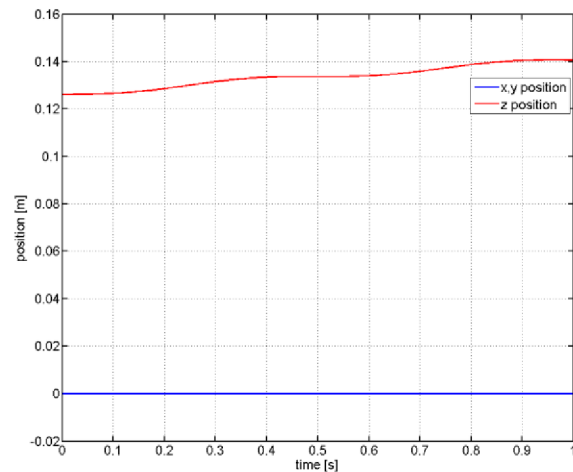

Fig. 7.2 Position of the platform during the simulation (nonlinear model)

There were compared outputs of both models (angular displacement and angular velocity of the screw nut) during the simulation, Fig. 7.3, 7.4.

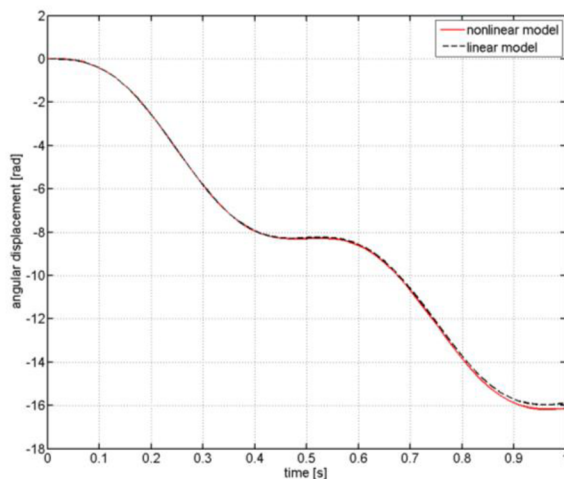

Fig. 7.3 Comparison between linear and nonlinear model – angular displacements

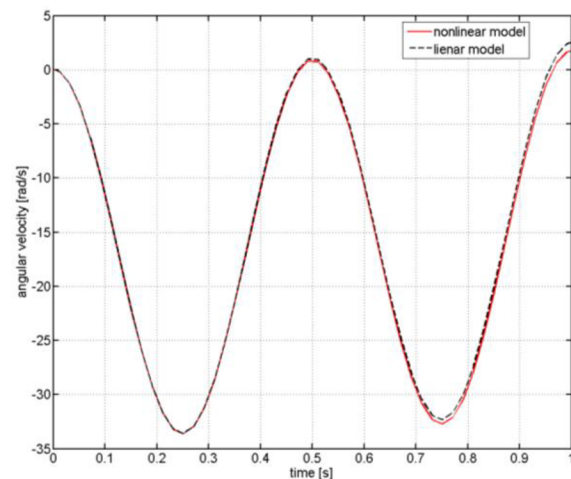

Fig. 7.4 Comparison between linear and nonlinear model – angular velocities

The behavior of the linear model is obvious and expected – with increasing distance from the operating point decreases identity of both models. The difference between outputs is approximately 1,5% (angular displacement) and 2,1% (angular velocity) close to the workspace borders.

Advantage of such a linear model is that it is with its twelve states quite simple. Thus its simulations are very fast and model itself is for its computational modesty suitable for a control design.

The minimal realization of the obtained linear state – space model satisfied conditions of controllability and observability.

8. Stewart platform control design based on the SimMechanics model

The Stewart platform linear state-space model was obtained in the previous chapter. The model was used for a control design which described in [8]. The control was successfully tested with original SimMechanics nonlinear model.

The basic idea of the control structure is to divide it into two layers – upper and lower layer. The upper layer is represented by a multichannel PID controller which prescribes torques produced by DC motors according to a desired position and orientation of the platform. The desired position and orientation of the platform may be easily transformed into linear actuators extensions and screw nuts angular displacements by using inverse kinematics description. The controller representing this layer is based on the Stewart platform linear state-space model.

The lower layer consists of six independent PID controllers which prescribe driving voltages for each of six DC motors according to the torques prescribed by the upper layer. The controllers in this layer are based on the state-space model of the DC motor.

The comparison between desired and measured position and orientation of the platform gravity center is documented in Fig. 8.1, 8.2, 8.3.

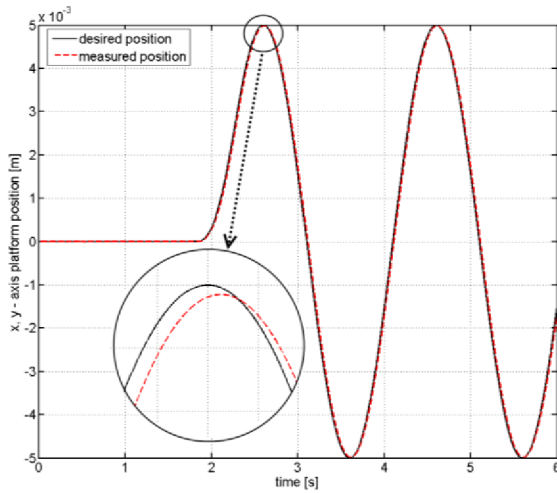

Fig. 8.1 X, Y – axis position of the platform gravity center (desired and measured)

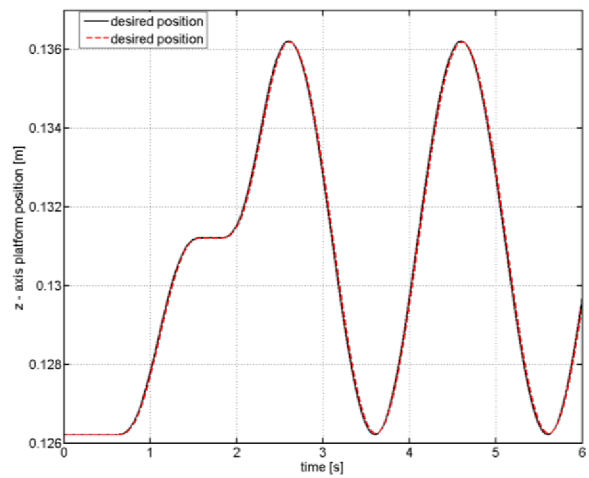

Fig. 8.2 Z – axis position of the platform gravity center (desired and measured)

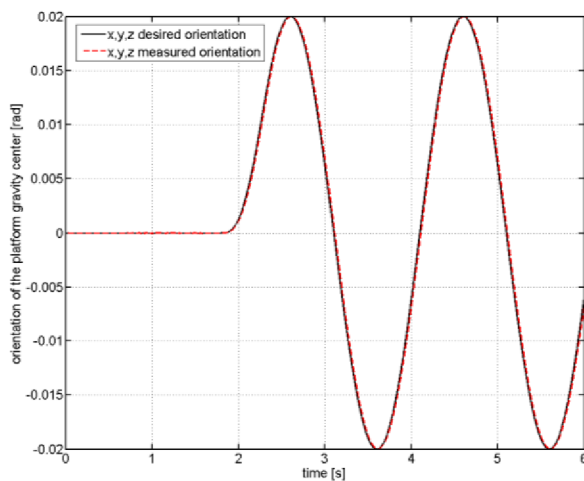

Fig. 8.3 Orientation of the platform gravity center (desired and measured)

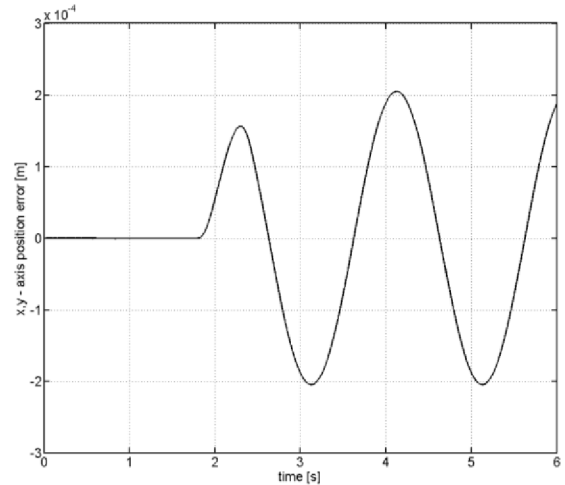

Fig. 8.4 Position error (x, y - axis)

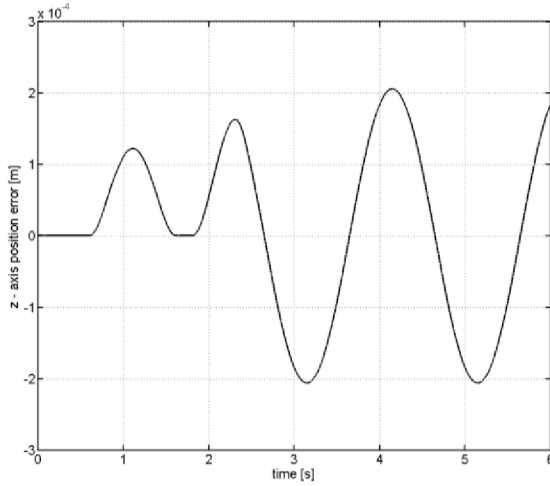

Fig. 8.5 Position error (z - axis)

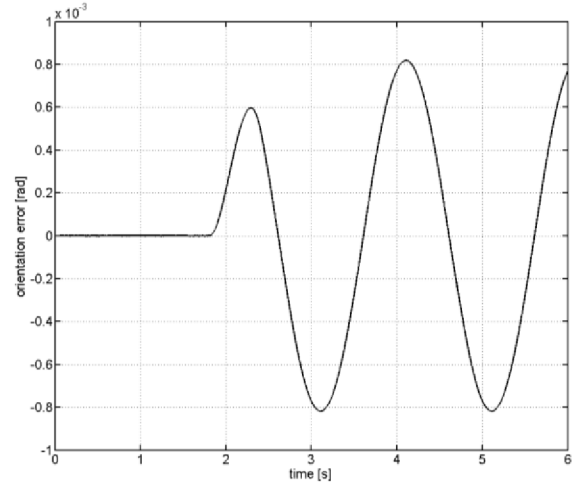

Fig. 8.6 Orientation error (x, y, z - axis)

The position and orientation error is then documented in figures Fig. 8.4 - 8.6. The maximal positioning error is approximately 0,2mm for movement in each axis. The maximal orientation error is approximately $0,8 \cdot 10^{-3}$ rad for rotation around each axis. There is no special requirement on the device positioning accuracy because of its planned use. Hence the presented accuracy is sufficient.

9.Uncertain modeling

10.1 Model of the DC motor with uncertain parameters

The following DC motor model with uncertain parameters is based on description (6.1) and standard principles of uncertain modeling [27]. The equations may be for $x_1 = i$, $x_2 = \omega$ and by introducing the parametric uncertainty transformed into a form

$$\begin{aligned} x_1' &= \frac{1}{(\bar{L} + \delta_L)} \left[-(\bar{R} + \delta_R)x_1 - (\bar{K}_b + \delta_{Kb})x_2 + u \right] \\ x_2' &= \frac{1}{(\bar{J} + \delta_J)} \left[(\bar{K}_m + \delta_{Km})x_1 - (\bar{K}_f + \delta_{Kf})x_2 \right] \end{aligned} \quad (9.1)$$

where \bar{L} , \bar{R} , \bar{K}_b , \bar{J} , \bar{K}_m , \bar{K}_f are nominal parameters and δ_L , δ_R , δ_{Kb} , δ_J , δ_{Km} , δ_{Kf} are uncertainties of the nominal parameters.

The uncertain model in matrix form is then obtained as a compact form of interconnection matrix **M**

$$\begin{bmatrix} x_1' \\ x_2' \\ z_1 \\ z_2 \\ z_3 \\ z_4 \\ z_5 \\ z_6 \\ \omega \end{bmatrix} = \begin{bmatrix} -\bar{R}/\bar{L} & -\bar{K}_b/\bar{L} & -1 & -1 & 0 & 0 & 0 & -1 & 0 \\ \bar{K}_m/\bar{J} & -\bar{K}_f/\bar{J} & 0 & 0 & -1 & -1 & 1 & 0 & 0 \\ -\bar{R}/\bar{L} & -\bar{K}_b/\bar{L} & -1 & -1 & 0 & 0 & 0 & -1 & 1/\bar{L} \\ 1 & 0 & 0 & 0 & 0 & 0 & 0 & 0 & 0 \\ \bar{K}_m/\bar{J} & -\bar{K}_f/\bar{J} & 0 & 0 & -1 & -1 & 1 & 0 & 0 \\ 0 & 1 & 0 & 0 & 0 & 0 & 0 & 0 & 0 \\ 1 & 0 & 0 & 0 & 0 & 0 & 0 & 0 & 0 \\ 0 & 1 & 0 & 0 & 0 & 0 & 0 & 0 & 0 \\ 0 & 1 & 0 & 0 & 0 & 0 & 0 & 0 & 0 \end{bmatrix} \begin{bmatrix} x_1 \\ x_2 \\ d_1 \\ d_2 \\ d_3 \\ d_4 \\ d_5 \\ d_6 \\ u \end{bmatrix} \quad (9.2)$$

At the same time the perturbation matrix Δ is defined as

$$\begin{bmatrix} d_1 \\ d_2 \\ d_3 \\ d_4 \\ d_5 \\ d_6 \end{bmatrix} = \begin{bmatrix} \delta_L & 0 & 0 & 0 & 0 & 0 \\ 0 & \delta_R & 0 & 0 & 0 & 0 \\ 0 & 0 & \delta_J & 0 & 0 & 0 \\ 0 & 0 & 0 & \delta_{Kf} & 0 & 0 \\ 0 & 0 & 0 & 0 & \delta_{Km} & 0 \\ 0 & 0 & 0 & 0 & 0 & \delta_{Kb} \end{bmatrix} \begin{bmatrix} z_1 \\ z_2 \\ z_3 \\ z_4 \\ z_5 \\ z_6 \end{bmatrix}. \quad (9.3)$$

10.2 Stewart platform model with uncertain parameters

The general approach to the parametric uncertainty modeling presented in the previous section is suitable for models where individual parameters are treated as uncertain. The method is strictly concentrated on the given parameters but this might be inconvenient for models of higher orders with large amount of parameters with an uncertainty or for models where the uncertainty in some parameters influences other parameters.

The proposed method works with parametric uncertainty in a more complex way. It is based on knowledge of an uncertain linear model and corresponding linear model with maximally perturbed parameters. The uncertainty is then determined for each parameter of state matrices individually.

The general principle of the uncertain modeling is then following. The nominal system is described as

$$\dot{\mathbf{x}} = \bar{\mathbf{A}}\mathbf{x} + \bar{\mathbf{B}}\mathbf{u} \quad (9.4)$$

$$\mathbf{y} = \bar{\mathbf{C}}\mathbf{x} + \bar{\mathbf{D}}\mathbf{u}$$

and similarly the model with maximally perturbed parameters

$$\begin{aligned} \dot{\mathbf{x}} &= \mathbf{A}\mathbf{x} + \mathbf{B}\mathbf{u} \\ \mathbf{y} &= \mathbf{C}\mathbf{x} + \mathbf{D}\mathbf{u} \end{aligned} \quad (9.5)$$

The meaning of equation terms is in case of the Stewart platform state-space model following:

\mathbf{x} represents the vector of twelve states which are established by SimMechanics during the linearization, $\dot{\mathbf{x}}$ represents the vector of the time derivations of the states, $\mathbf{u} = [M_1 \ M_2 \ M_3 \ M_4 \ M_5 \ M_6]^T$ is the vector of inputs which are DC motors shaft torques, $\mathbf{y} = [\varphi_1 \ \varphi_2 \ \varphi_3 \ \varphi_4 \ \varphi_5 \ \varphi_6 \ \omega_1 \ \omega_2 \ \omega_3 \ \omega_4 \ \omega_5 \ \omega_6]^T$ is the vector of outputs which are angular displacement and angular velocity of each one of the ball screw nuts. Matrices $\bar{\mathbf{A}}, \bar{\mathbf{B}}, \bar{\mathbf{C}}, \bar{\mathbf{D}}$ represent state matrices of the nominal system and $\mathbf{A}, \mathbf{B}, \mathbf{C}, \mathbf{D}$ represent the state matrices of the model with perturbed parameters.

State matrices of the system (9.5) may be defined as a sum of particular nominal matrix and a matrix containing the uncertainty. E.g. for A it is

$$\mathbf{A} = \bar{\mathbf{A}} + \mathbf{A}_\Delta, \quad (9.6)$$

thus the uncertainty contribution is $\mathbf{A}_\Delta = \mathbf{A} - \bar{\mathbf{A}}$. Similarly are derived uncertainty contributions for matrices $\mathbf{B}, \mathbf{C}, \mathbf{D}$.

Applying of the upper linear fractional transformation

$$\mathbf{F}_u(\mathbf{M}, \Delta_u) = \mathbf{M}_{22} + \mathbf{M}_{21} \Delta_u (\mathbf{I} - \mathbf{M}_{11} \Delta_u)^{-1} \mathbf{M}_{12} \quad (9.7)$$

and comparing with (9.6) it is obtained $\mathbf{M}_{21} \mathbf{M}_{12} = \mathbf{A}_\Delta$, $\mathbf{M}_{11} = \mathbf{0}$, $\mathbf{M}_{12} = \mathbf{I}$, $\mathbf{M}_{21} = \mathbf{A}_\Delta$ and $\mathbf{M}_{22} = \bar{\mathbf{A}}$. The method is same for other state matrices.

$$\begin{bmatrix} \dot{\mathbf{x}} \\ \mathbf{y}_{\Delta A} \\ \mathbf{y}_{\Delta B} \\ \mathbf{y}_{\Delta C} \\ \mathbf{y}_{\Delta D} \\ \mathbf{y} \end{bmatrix} = \begin{bmatrix} \bar{\mathbf{A}} & \mathbf{A}_\Delta & \mathbf{B}_\Delta & \mathbf{0} & \mathbf{0} & \bar{\mathbf{B}} \\ \mathbf{I} & \mathbf{0} & \mathbf{0} & \mathbf{0} & \mathbf{0} & \mathbf{0} \\ \mathbf{0} & \mathbf{0} & \mathbf{0} & \mathbf{0} & \mathbf{0} & \mathbf{I} \\ \mathbf{I} & \mathbf{0} & \mathbf{0} & \mathbf{0} & \mathbf{0} & \mathbf{0} \\ \mathbf{0} & \mathbf{0} & \mathbf{0} & \mathbf{0} & \mathbf{0} & \mathbf{I} \\ \bar{\mathbf{C}} & \mathbf{0} & \mathbf{0} & \mathbf{C}_\Delta & \mathbf{D}_\Delta & \bar{\mathbf{D}} \end{bmatrix} \begin{bmatrix} \mathbf{x} \\ \mathbf{u}_{\Delta A} \\ \mathbf{u}_{\Delta B} \\ \mathbf{u}_{\Delta C} \\ \mathbf{u}_{\Delta D} \\ \mathbf{u} \end{bmatrix}, \quad (9.8)$$

with the perturbation matrix

$$\begin{bmatrix} \mathbf{u}_{\Delta A} \\ \mathbf{u}_{\Delta B} \\ \mathbf{u}_{\Delta C} \\ \mathbf{u}_{\Delta D} \end{bmatrix} = \begin{bmatrix} \Delta_{\Delta A} & \mathbf{0} & \mathbf{0} & \mathbf{0} \\ \mathbf{0} & \Delta_{\Delta B} & \mathbf{0} & \mathbf{0} \\ \mathbf{0} & \mathbf{0} & \Delta_{\Delta C} & \mathbf{0} \\ \mathbf{0} & \mathbf{0} & \mathbf{0} & \Delta_{\Delta D} \end{bmatrix} \begin{bmatrix} \mathbf{y}_{\Delta A} \\ \mathbf{y}_{\Delta B} \\ \mathbf{y}_{\Delta C} \\ \mathbf{y}_{\Delta D} \end{bmatrix}. \quad (9.9)$$

The advantage of the method is that formulas (9.8), (9.9) describing the uncertain model are applicable on any state-space model of any system. The only necessary inputs are a nominal model and a model with maximally perturbed parameters.

The proposed method was published in [5]. The article also describes a brief experiment with an H-infinity based controller designed according to the uncertain model.

10. The model verification

The following chapter is dealing with verification of the proposed SimMechanics and derived uncertain models. The verification was performed for the single linear actuator with the DC.

The verification itself is based on comparison between measured and simulated values of the angular displacement and the angular velocity of the motor shaft on a single link for the same input voltage. The link is during the experiment part of a test jig which guarantees only linear movement of the attached cart, Fig. 10.1.



Fig. 10.1 Test jig with the linear actuator

The following pictures (Fig 10.2 – 10.5) documents comparison between measured data and data obtained from the simulation. The simulation was performed for the nominal (SimMechanics) model of the link with the nominal (Simulink) model of the DC motor.

The maximal difference between the data obtained from the simulation and from the experiment is 11% in case of the angular displacement and 12,5% in case of the angular velocity for the given input voltage.

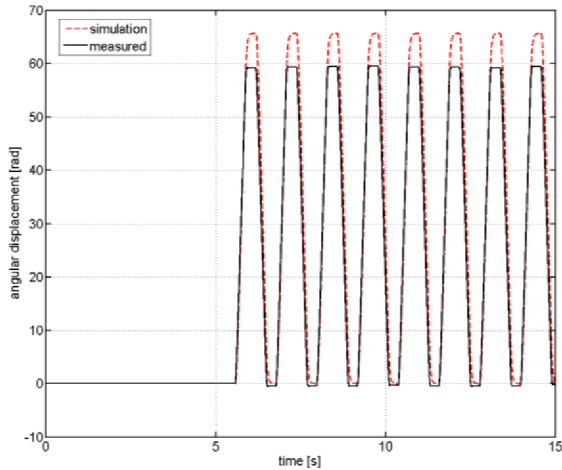

Fig. 10.2 Comparison of measured and simulated data for nominal models (motor and link) – angular displacement

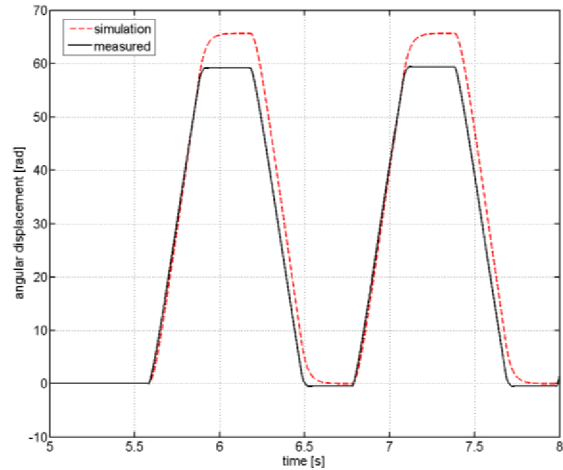

Fig. 10.3 Comparison of measured and simulated data for nominal models (motor and link) – angular displacement (detail)

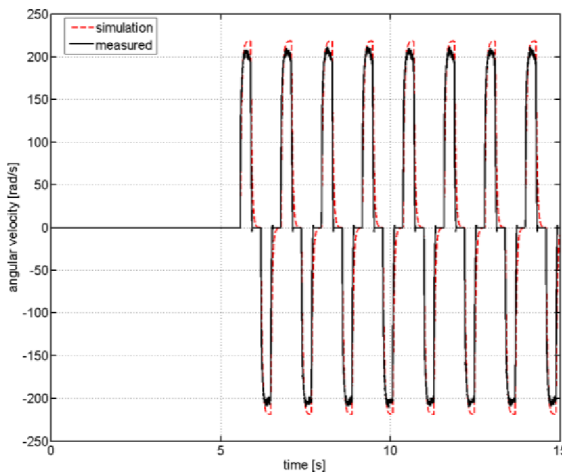

Fig. 10.4 Comparison of measured and simulated data for nominal models (motor and link) – angular velocity

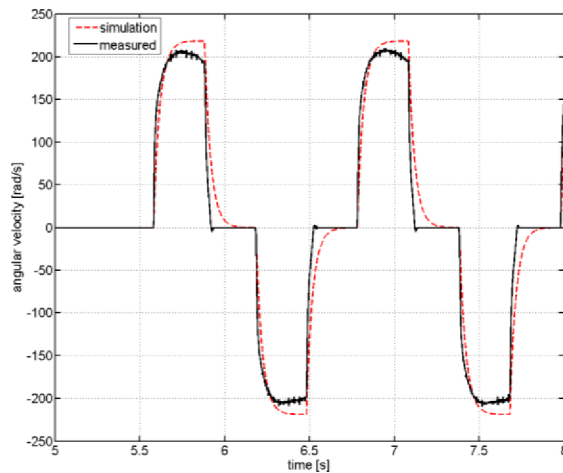

Fig. 10.5 Comparison of measured and simulated data for nominal models (motor and link) – angular velocity (detail)

Such a difference may be caused by nonlinearities in the system, modeling inaccuracy, etc. This may be at least partially compensated by the proposed uncertain model.

The simulation results closest to the measured data were obtained for the combination of the uncertain model of the DC motor with the uncertain model of the link. The peak values of the measured data are covered by the uncertainty, Fig. 10.6 – 10.9.

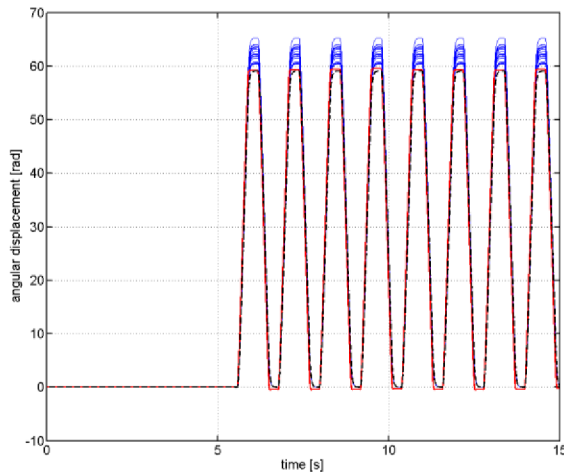

Fig. 10.6 Comparison of measured and simulated data for uncertain model of the motor and uncertain model of the link – angular displacement
(black dashed line – measured data, red full line – the worst case, blue full line – samples of the uncertain model)

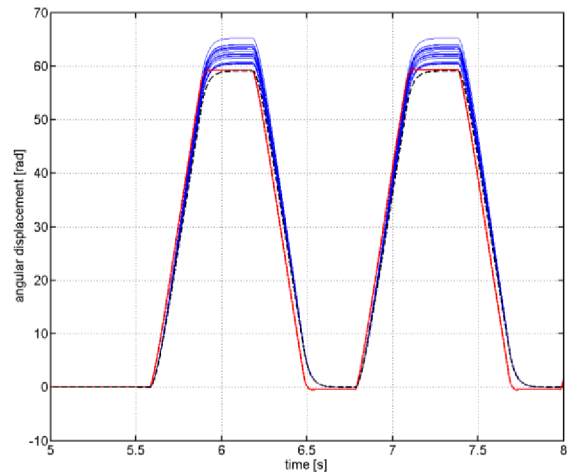

Fig. 10.7 Comparison of measured and simulated data for uncertain model of the motor and uncertain model of the link – angular displacement (detail)

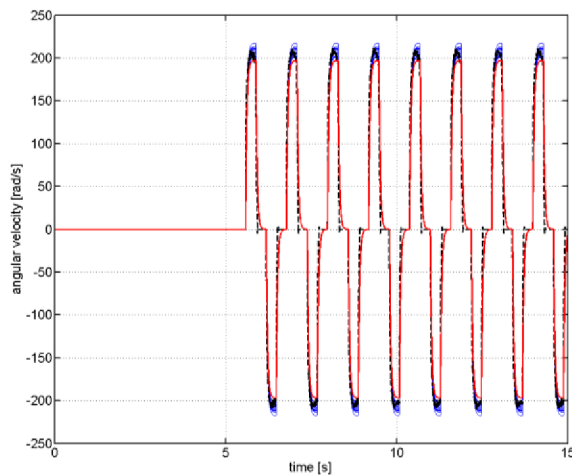

Fig. 10.8 Comparison of measured and simulated data for uncertain model of the motor and uncertain model of the link – angular velocity
(black dashed line – measured data, red full line – the worst case, blue full line – samples of the uncertain model)

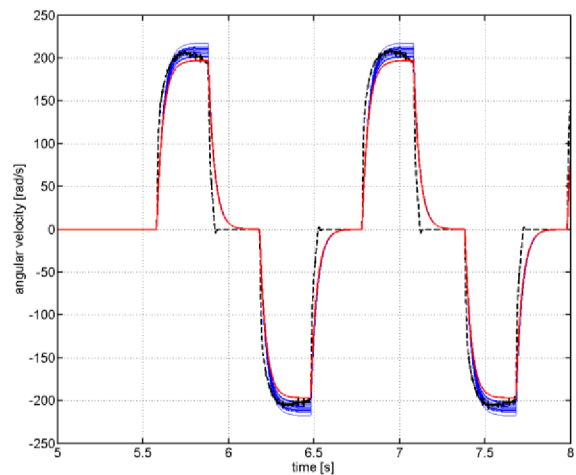

Fig. 10.9 Comparison of measured and simulated data for uncertain model of the motor and uncertain model of the link – angular velocity (detail)

The last presented example is the most suitable for the robust control design of the device. The worst case of the uncertain model is very close to the measured data, thus the robust controller designed according to such a model should be able to stabilize even the real machine.

The model is still keeping its simple structure and computational modesty of the linear model. Let's note that all worst cases of the previous examples are controllable and observable.

11. Results

The proposed work presents an approach for building of dynamic models of parallel kinematics machines optimal for a control design purposes. Such an optimal model must satisfy following requirements:

- evaluation in the shortest possible time,
- possibility of the processing of the deviations from the reality,
- (simple) investigation of the system controllability
- (simple) investigation if it is possible to use the model for estimation of selected parameters (especially in cases of parameters which is difficult or impossible to measure)

The approach is based on modeling of the system dynamics and kinematics in Matlab SimMechanics followed by a linearization of the system and introducing of uncertain parameters. The inverse kinematics was also derived by classical analytical approach for the control purposes.

The approach is presented on a Stewart platform which is a parallel manipulator with six degrees of freedom. The obtained linear model from SimMechanics is for its state-space representation with twelve states in case of Stewart platform quite simple thus it is computationally modesty with possible real-time evaluation. The model also satisfied conditions of observability and controllability.

The linear model was consequently used for a controller design which was successfully tested with the original nonlinear SimMechanics model.

The modeling itself introduced some modeling errors which, according to the verification with the assembled linear actuator, caused approximately 11% difference between outputs of the real and simulated system.

The modeling inaccuracies caused by the linearization or inexact definition of the model parameters were compensated by defining of uncertain parameters and describing the system as uncertain. The method is based on definition of structured parametric uncertainty for a nominal linear model. The uncertainty is given by a difference between corresponding parameters of state matrices of the nominal model and a model with maximally perturbed parameters. The method is then treating all of the individual parameters in the state matrices as uncertain. The proposed approach is especially advantageous for large scale models where defining of a parametric uncertainty individually for all of the system parameters would be very demanding.

The application of the method results into an uncertain model which keeps its state-space structure thus its simplicity and computational modesty. Such a model is suitable for analyzing of the “worst case scenario” and for designing of a robust controller.

The uncertainty modeling was used for designing of uncertain model of a DC motor which is part of the Stewart platform linear actuators. In this case the classical approach [33] was chosen. The uncertainty was defined for the only motor parameter representing the linear approximation of the viscous friction where is large possible source of the modeling inaccuracy.

The proposed approach of the uncertainty modeling was applied in case of the uncertain model of the Stewart platform. The model is of the twelve order, thus it would be uncomfortable to set the uncertainty for the each parameter individually. The proposed method was used for constructing of a model describing the inaccuracy caused by the linearization, i.e. shifting of operating points within the workspace. The second example of the Stewart platform uncertain model describes the inaccuracy in body parameters of masses and inertia moments.

The mentioned 11% difference between outputs of the real and simulated system was then by introducing of the uncertain model almost completely covered by the uncertainties. There was used a model combining the uncertain model of the DC motor with the uncertain model of the Stewart platform linear actuator for this purpose.

The obtained uncertain model is optimal for the robust control because of its ability to describe the model inaccuracies which will be compensated by a robust controller.

The proposed method of uncertain modeling was demonstrated on the Stewart platform parallel manipulator thus its suitability for the modeling of parallel manipulators was proved. The method is very versatile and applicable on any model which is possible to describe in a state-space form. Design of an uncertain model for a robust control design purposes is with obtained formulas (9.8), (9.9) very simple and only necessary inputs are a nominal model and a model with maximally perturbed parameters.

The method reflects actual industry needs leading to increase of a product quality, preciseness, production capacity, dependability, system economy and decrease of the environment damage. The simulation and control of the system significantly influences all of these needs.

Acknowledgement

The presented work was supported from projects MSM0021630518 "Simulation modeling of mechatronic systems" and MŠMT KONTAKT 1P05ME789 "Simulation of mechanical function of selected elements of human body".

References

- [1] Angeles, J., Zanganeh, K.E: The semi-graphical solution of the direct kinematics of general platform manipulators. *Proceedings of ISRAM*, Santa-Fe, 1992
- [2] Boudreau, R., Turkkan N.: Solving the forward kinematics of parallel manipulators with a genetic algorithm. *Journal of Robotic Systems*, Vol. 13(2) (1996), p. 111-125
- [3] Bruzzone, L., Molino, R., Zoppi, M., Zurlo, G.: The pride prototype: Control layout of a parallel robot for assembly tasks. *Proceedings of International Conference on Modelling, identification and control MIC2003*, Innsbruck, 2003
- [4] Březina, L., Andrš, O., Březina, T.: NI LabView – Matlab SimMechanics Stewart platform design. *Applied and computational mechanics*, Vol. 2 (1) (2008), p. 235 -242
- [5] Březina, L., Březina, T.: Stewart Platform Model with Uncertain Parameters. *Solid state phenomena*, Vol. 164 (2010), p.177 – 182
- [6] Březina, T. et al.: *Simulation modelling of mechatronic systems II*. BUT, Brno, 2006
- [7] Březina, T. et al.: *Simulation modelling of mechatronic systems III*. BUT, Brno, 2007
- [8] Březina, T., Březina, L.: The device for implants testing: The control. *Proceedings of Engineering mechanics 2008*, Svatka, 2008
- [9] Byun, Y., Cho, H., Kim, W., Baek, S., Chang, H., Ro, K.: Kinematic/Dynamic Analysis, of a 6 DOF Parallel Manipulator with 3-PPSP Serial Subchains and its Implementation. *Proceedings of the IEEE/RSJ*, Canada, 1998
- [10] Carvalho, J. C. M., Ceccarelli, M.: A Closed-Form Formulation for the Inverse Dynamics of a Cassino Parallel Manipulator. *Multibody System Dynamics*, Vol. 5(2) (2001), p. 185 – 210
- [11] Cheng, H., Yiu, Y., Li, Z.: Dynamics and Control of Redundantly Actuated Parallel Manipulators. *IEEE/ASME Transactions on Mechatronics*, Vol. 8(4) (2003), p. 483 - 491
- [12] Choi, H. B., Company, O., Pierot, F., Konno, A., Shibukawa, T.: Design and Control of a Novel 4-DOFs Parallel Robot H4. *Proceedings of IEEE International Conference on Robotics and Automation*, 2003
- [13] Codourey, A., Burdet, E.: A Body-oriented Method for Finding a Linear Form of the Dynamic Equation of Fully Parallel Robots. *Robotics and Automation*, Vol. 2 (1997), p. 1612 - 1618
- [14] Dasgupta, B., Choudhury, P.: A general strategy based on the Newton-Euler approach for the dynamic formulation of parallel manipulators. *Mechanism and Machine Theory*, Vol. 34(6) (1999), p. 801 - 824
- [15] Dasgupta, B., Mruthyunjaya, T. S.: A Newton-Euler formulation for the inverse dynamics of the Stewart platform manipulator. *Mechanism and Machine Theory*, Vol. 33(8) (1998), p. 1135 - 1152
- [16] Dasgupta, B., Mruthyunjaya, T.S.: A canonical formulation of the direct position kinematics for a general 6-6 Stewart platform. *Mechanism and Machine Theory*, Vol. 29(6) (1994), p. 819-827
- [17] Dasgupta, B., Mruthyunjaya, T. S.: Closed-form dynamic equations of the general Stewart platform through the Newton-Euler approach. *Mechanism and Machine Theory*, Vol. 33(7) (1998), p. 993 - 1012

- [18] Davliakos, I., Papadopoulos, E.: Invariant Error Dynamics Controller for a 6-dof Electrohydraulic Stewart Platform. *Proceeding of 6th CISM-IFTOMM Symposium on Robot Design, Dynamics, and Control*, Warsaw, 2006
- [19] Davliakos, I., Papadopoulos, E.: Model-based control of a 6-dof electrohydraulic Stewart–Gough platform. *Mechanism and Machine Theory*, Vol. 43(11) (2008), p. 1485 - 1600
- [20] Denkena, B., Grendel, H., Holz, Ch.: Model based feedforward and state control of the parallel kinematics PaLiDA. *Proceedings of the 4th Parallel kinematics seminar*, Chemnitz, 2004
- [21] Do, W. Q. D., Yang, D. C. H.: Inverse dynamic analysis and simulation of a platform type robot. *Journal of Robotic Systems*, Vol. 5(3) (1988), p. 209 – 227
- [22] Fichter, E.F.: A Stewart platform-based manipulator: general theory and practical construction. *The International Journal of Robotics Research*, Vol. 5(2) 1986, p. 157 -182
- [23] Gallardo, J., Rico, J. M., Frisoli, A., Checcacci, D., Bergamasco, M.: Dynamics of parallel manipulators by means of screw theory. *Mechanism and Machine Theory*, Vol. 38(11) (2003), p. 1113 - 1131
- [24] Gosselin, C.: Parallel computational algorithms for the kinematics and dynamics of planar and spatial parallel manipulators. *ASME Journal of Dynamic Systems, Measurement and Control*, Vol. 118(1) (1996), p. 22-28
- [25] Gough, V.E., Whitehall, S.G.: Universal tire test machine. *Proceedings of 9th Int. Technical Congress F.I.S.I.T.A.*, London, 1962
- [26] Green, M., Limebeer, D.J.N: *Linear robust control*. Prentice-Hall, 1994
- [27] Gu, D.W., Petrov, P.H., Konstantinov, M.M.: *Robust Control Design with Matlab*. Springer, 2005
- [28] Haddad, W.M, Leonessa, A., Corrado, J.R., Kapila, V.: State space modeling and robust reduced-order control of combustion instabilities. *Journal of Franklin Institute*, Vol. 336(8) (1999), p. 1283 - 1307
- [29] Inoue, H., Tsusaka, Y., Fukuizumi, T.: Parallel manipulator. *Proceedings of ISRR*, Gouvieux, 1985
- [30] Krabbes, M., Meissner, Ch.: Dynamic modeling and control of a 6 DOF parallel kinematics. *Proceedings of Modelica 2006*
- [31] Lee, S., Song, J., Choi, W., Hong, D.: Position control of a Stewart platform using inverse dynamics control with approximate dynamics. *Mechatronics*, Vol. 13(6) (2003), p. 605 - 619
- [32] Lee, T-Y, Shim, J-K: Forward kinematics of the general 6-6 Stewart platform using algebraic elimination. *Mechanism and Machine Theory*, Vol. 36 (2001), p. 1073-1085
- [33] Levine, P., McAdam, P., Pearlman, J., Pierse, R.: *Risk management in action: robust monetary rules under structured uncertainty*. European central bank, Frankfurt am Mein, 2008
- [34] Li, M., Huang, T., Mei, J., Zhao, X.: Dynamic Formulation and Performance Comparison of the 3-DOF Modules of Two Reconfigurable PKM—the Triceps and the TriVariant. *Journal of Mechanical Design*, Vol. 127 (2005), p. 1129 - 1136

- [35] Li, D., Salcudean, S.: Modeling, Simulation, and Control of a Hydraulic Stewart Platform. *Proceedings of International Conference on Robotics and Automation*, Albuquerque, 1997
- [36] Li, Q., Wu, F.: Control performance improvement of a parallel robot via the design for control approach. *Mechatronics*, Vol. 14(8) (2004), p. 947 – 964
- [37] Liu, K., Fitzgerald J.M., Lewis, F.L.: Kinematic analysis of a Stewart platform manipulator. *IEEE Transactions on Industrial Electronics*, Vol.40(2) (1993), p. 282 - 293
- [38] Liu, M., Li, C., Li, Ch.: Dynamics Analysis of the Gough–Stewart Platform Manipulator. *IEEE/ASME Transactions on Mechatronics*, Vol. 16(1) (2000), p. 94 - 98
- [39] Merlet, J. P.: *Parallel robots, 2nd Edition*. Kluwer Academic Publishers, Dordrecht, 2005
- [40] Merlet, J. P.: Solving the forward kinematics of a Gough-type parallel manipulator with interval analysis. *The International Journal of Robotics Research*, Vol. 23(3) (2004), p. 221 - 235
- [41] Miller, K.: Dynamics of the New UWA Robot. *Proceedings of Australian Conference on Robotics and Automation*, Sydney, 2001
- [42] Morari, M., Zafiriou, E.: *Robust Process Control*. Prentice-Hall, Englewood Cliffs, 1989
- [43] Neugebauer, R., Denkena, B., Wegener, K.: Mechatronic systems for machine tools. *Annals of the CIRP*, Vol. 56(2) (2007)
- [44] Pierrot, F., Dauchez, P., Fournier, A.: Fast parallel robots. *Journal of Robotic Systems*, Vol. 8(6) (1991), pp. 829 - 840
- [45] Reboulet, C., Berthomieu, T.: Dynamic model of a six degree of freedom parallel manipulator. *Proceedings of ICAR*, Pise, 1991
- [46] Sahinkaya, M., Li, Y.: Motion planning and control of parallel mechanisms through inverse dynamics. *Proceedings of IUTAM Symposium on Vibration Control of Nonlinear Mechanisms and Structures*, 2005
- [47] Salhi, M.A. et al.: Structured Uncertainty Assessment for Fahud Field through the Application of Experimental Design and Response Surface Methods. *Proceedings of SPE Middle East Oil and Gas Show and Conference*, Kingdom of Bahrain, 2005
- [48] Smith, N., Wendlandt, J.: Creating a Stewart platform model using Matlab SimMechanics. *Matlab Digest*, Vol. 10(5) (2002)
- [49] Vivas, A., Poignet, P., Pierot, F.: Predictive functional control for a parallel robot. *Proceedings of International Conference on Intelligent Robots and Systems*, 2003
- [50] Wang, S., Hikita, H., Kubo., H., Zhao., Y., Huang., Z., Ifukube, T.: Kinematics and dynamics of a 6 degree-of-freedom fully parallel manipulator with elastic joints. *Mechanism and Machine Theory*, Vol. 38(5) (2003), p. 439 - 461
- [51] Wang, J., Wu, J., Wang, L., Li, T.: Simplified strategy of the dynamic model of a 6-UPS parallel kinematic machine for real-time control. *Mechanism and Machine Theory*, Vol. 42(9) (2007), p. 1119 - 1140
- [52] Wu, F., Zhang, W., Li, Q., Ouyang, P.: Integrated Design and PD Control of High-Speed Closed-loop Mechanisms. *Journal of Dynamic Systems, Measurement, and Control*, Vol. 124(4) (2002), p. 522 – 528
- [53] Yang, Z., Wu, J., Mei, J., Gao, J., Huang, T.: Mechatronic Model Based Computed Torque Control of a Parallel Manipulator. *International Journal of Advanced Robotic Systems*, Vol. 5(1) (2008), p. 123 – 128