

BRNO UNIVERSITY OF TECHNOLOGY

Faculty of Electrical Engineering
and Communication

BACHELOR'S THESIS

Brno, 2018

Lubajo Moses Wolyan Lubajo



BRNO UNIVERSITY OF TECHNOLOGY

VYSOKÉ UČENÍ TECHNICKÉ V BRNĚ

FACULTY OF ELECTRICAL ENGINEERING AND COMMUNICATION

FAKULTA ELEKTROTECHNIKY
A KOMUNIKAČNÍCH TECHNOLOGIÍ

DEPARTMENT OF TELECOMMUNICATIONS

ÚSTAV TELEKOMUNIKACÍ

IMPLEMENTATION OF THE NB-IOT AND LTE-M TECHNOLOGIES WITHIN THE NS-3 SIMULATION TOOL

IMPLEMENTACE KOMUNIKAČNÍCH TECHNOLOGIÍ NB-IOT A LTE-M V SIMULAČNÍM NÁSTROJI NS-3

BACHELOR'S THESIS

BAKALÁŘSKÁ PRÁCE

AUTHOR

AUTOR PRÁCE

Lubajo Moses Wolyan Lubajo

SUPERVISOR

VEDOUCÍ PRÁCE

Ing. Pavel Mašek, Ph.D.

BRNO 2018

Bakalářská práce

bakalářský studijní obor **Teleinformatika**

Ústav telekomunikací

Student: Lubajo Moses Wolyan Lubajo

ID: 189517

Ročník: 3

Akademický rok: 2017/18

NÁZEV TÉMATU:

Implementace komunikačních technologií NB-IoT a LTE-M v simulačním nástroji NS-3

POKYNY PRO VYPRACOVÁNÍ:

Cílem bakalářské práce bude seznámení se s nově nastupujícími technologiemi Narrow-band IoT (NB-IoT) a LTE-MTC (LTE-M) a následná implementace komunikačních scénářů pro přenos Machine-to-Machine (M2M) dat v síťovém simulačním nástroji Network Simulator 3 (NS-3). V teoretické části práce bude provedeno porovnání dostupných LPWAN technologií, kdy bude důraz kladen zejména na detailní analýzu technologií LoRaWAN, Sigfox, NB-IoT a LTE-M. Následná praktická část se bude sestávat z vytvoření M2M komunikačního scénáře s využitím modulu LENA (podpora LTE/LTE-A). Student dále navrhne a implementuje úpravy modulu LENA dle dokumentace pro LTE-M či NB-IoT.

DOPORUČENÁ LITERATURA:

[1] LIBERG, Olof, Marten SUNDBERG, Eric WANG, Johan BERGMAN a Joachim SACHS: Cellular Internet of Things: Technologies, Standards, and Performance, 2017. První vydání. ISBN 978-0128124581.

[2] BOSWARTHICK, David, Omar ELLOUMI a Olivier HERSENT. 2012. M2M communications: a systems approach. Hoboken, N.J.: Wiley, xxiii, 308 p. ISBN 978-1-119-99475-6.

Termín zadání: 5.2.2018

Termín odevzdání: 29.5.2018

Vedoucí práce: Ing. Pavel Mašek, Ph.D.

Konzultant:

prof. Ing. Jiří Mišurec, CSc.
předseda oborové rady

UPOZORNĚNÍ:

Autor bakalářské práce nesmí při vytváření bakalářské práce porušit autorská práva třetích osob, zejména nesmí zasahovat nedovoleným způsobem do cizích autorských práv osobnostních a musí si být plně vědom následků porušení ustanovení § 11 a následujících autorského zákona č. 121/2000 Sb., včetně možných trestněprávních důsledků vyplývajících z ustanovení části druhé, hlavy VI. díl 4 Trestního zákoníku č.40/2009 Sb.

ABSTRACT

The Low Power Wide Area Network (LPWAN) consists of a number of wireless communication technologies that compete in the Machine Type Communication (MTC) space: Narrow Band Internet of Things (NB-IoT), Long Range (LoRaWAN) and Sigfox. Each has its own drawbacks and strengths. This bachelor thesis focused on the NB-IoT technology. It operates in licensed shared spectrum and offers increased link budget as well as extended coverage. The goal of this bachelor thesis is to create and implement an NB-IoT scenario in NS-3 Simulator. The results are discussed with respect to what was successfully implemented and improvements that still need to be made for comprehensive implementation of NB-IoT in the NS-3 Simulator.

KEYWORDS

Low Power Wide Area Network (LPWAN), Narrow Band Internet of Things (NB-IoT), Long Range (LoRa), Long Range Wide Area Network (LoRaWAN), Sigfox, Long Term Evolution (LTE), Network Simulator 3 (NS-3), LTE-EPC Network Simulator (LENA), Evolved Packet Core (EPC)

ABSTRAKT

Síť LPWA (Low-Power Wide-Area) je možné v dnešní době realizovat bezdrátovými komunikačními technologiemi NarrowBand IoT (NB-IoT), Long Range Wide Area Network (LoRaWAN) a Sigfox. Každá z technologií má výhody i nevýhody, které danou technologii předurčují pro specifické komunikační scénáře. Tato bakalářská práce je zaměřena na technologii NB-IoT a její implementaci v rámci simulačního nástroje NS-3. Získané výsledky jsou diskutovány.

KLÍČOVÁ SLOVA

LoRaWAN, Sigfox, mobilní síť 4. generace (LTE), síťový simulátor 3 (NS-3), LoRa, LENA, LTE-M

LUBAJO, Lubajo Moses Wolyan. *Implementace komunikačních technologií NB-IoT a LTE-M v simulačním nástroji NS-3*. Brno, 2017/18, 77 p. Bachelor's Thesis. Brno University of Technology, Fakulta elektrotechniky a komunikačních technologií, Ústav telekomunikací. Advised by Ing. Pavel Mašek, Ph.D.

ROZŠÍŘENÝ ABSTRAKT

ÚVOD

Cílem bakalářské práce je simulovat síťový scénář založený na bezdrátové (mobilní) komunikační technologii NarrowBand IoT (NB-IoT pomocí simulačního nástroje Network Simulator 3 (NS-3).

První kapitola práce pojednává o komunikačním schématu Internetu věcí (IoT). Je zde uvedeno porovnání komunikačních technologií pro přenos dat v rámci IoT: Long Range Wide Area Network (LoRaWAN), Sigfox, mobilní síť 4. generace zohledňující Machine to Machine přenosy (LTE-MTC nebo LTE-M) a NB-IoT.

Každá z uvedených bezdrátových komunikačních technologií a je v práci představena, přičemž důraz je kladen na Narrowband IoT. Popis NB-IoT zahrnuje podporované frekvence a způsobů nasazení (tj. in-band, guard-band and standalone), strukturu sítě (tj. jádrová a přístupová síť) a očekávaná životnost baterie a řízení výkonu u uživatelského zařízení, UE.

V navazujícím textu je pozornost soustředěna na dostupné simulační nástroje. NS-3, který se používá v této bakalářské práci, je popsán podrobně. Modul Long Term Evolution - Evolved Packet Core (LTE-EPC) Network Simulator (LENA) je taky popsán. Dále jsou stručně popsány další moduly dostupné v simulačním nástroji NS-3.

Vzhledem k tomu, že modul LENA je simulačním prostředím pro síť LTE, je třeba provést změny a úpravy tak, aby splňovaly požadavky NB-IoT, které mají různé parametry a potřeby. LTE je například navržena pro komunikaci typu člověk-člověku (H2H), která většinou vyžaduje interakce v reálném čase, a proto musí mít vysokou šířku pásma a rychlost. NB-IoT je na druhou stranu pro komunikaci typu stroje (MTC) a nevyžaduje vysokorychlostní komunikaci.

Praktická část bakalářské práce obsahuje návrh komunikačních scénáře s využitím komunikační technologie NB-IoT. Získané výsledky jsou následně popsány a je provedeno celkové zhodnocení.

POPIS ŘEŠENÍ

Jak bylo uvedeno výše, moduly NS-3 nejsou upraveny tak, aby vyhovovaly NB-IoT, a navíc v simulátoru NS-3 neexistuje žádný specifický modul pro NB-IoT. Byly navrženy následující změny, aby se v modulu LENA přizpůsobil NB-IoT:

- Použitá anténa: byla navržena třísektorová anténa. Tento typ antény není implementován jako jedna entita v NS-3, proto jsou tři samostatné uzly antény umístěny ve stejné pozici, z nichž každá má určitý úhel orientace tj., 0°, 120° a 240°. Tyto tři antény společně působí jako jedna třísektorová anténa. Kód pro generování tohoto typu antény je uveden v textu, Příloha A.3.

- Výchozí anténa v NS-3, Isotropická anténa, byla změněna s využitím modulu CosineAntennaModel. Rozptyl vysílání je nastavena na hodnotu 120° s využitím frekvence 800 MHz.

Navzdory všem předpovědím a očekáváním nebyly některé změny úspěšně provedeny. Po provedení změn v kódu došlo k určitým chybám. To mělo za následek, že některé parametry a atributy, které měly být implementovány, nejsou součástí finální verze. Jeden takový atribut je PathLossModel, který udává chybu, jak je znázorněno v Sekci 3.3 a na Obr. 3.3.

Vytvořený komunikační scénář je zobrazen na Obr. 4.1. Funkční části topologie jsou implementovány v simulačním nástroji NS-3. Základní konfigurace tj., EU, eNodeB, P-GW a remoteHost jsou provedeny s ohledem na charakteristiky a metody potřebné pro plnění jejich specifických úkolů.

Topologie je tvořena několika pevně umístěnými eNodeBs, P-GW a vzdáleným serverem pro příjem dat. Tyto uzly zůstanou v průběhu simulace na stejných místech. Síť dále obsahuje 500 pevných uzlů (UE), které jsou umístěny v náhodných pozicích. Umístění těchto koncových zařízení je generováno užitím RandomBoxPositionAllocator. Byl použit kód ukazano v části 4.1 užitím AttachToClosestEnb, tedy, UE vybírá EnodeB pro připojení na základě vzdálenosti mezi nimi. UE je připojeno k nejbližšímu EnodeB.

Pro generování provozu mezi UE a vzdáleným hostitelem, se používají dva transportní protokoly: Transport Control Protocol, TCP a User Datagram Protocol, UDP. Aplikace OnOffApplication se používá ke generování přenosu protokolu TCP. Pro provoz UDP se používá UdpClientHelper. První polovina zařízení používá UDP a druhá polovina používá protokol TCP.

SHRNUTÍ A ZHODNOCENÍ VÝSLEDKŮ

Simulace byly provedeny s využitím modulu LENA v rámci simulačního nástroje Network Simulator 3 (NS-3). V současné fázi se nepodařilo implementovat změny do stavu, aby mohl být scénář považovaný za připravený na využití NB-IoT technologie.

Je třeba ještě zvážit několik dalších věcí, aby simulace mohly kvalifikovat jako simulace pro NB-IoT. Jak již bylo uvedeno výše, změny, které nebyly úspěšně implementované (typ antény, UIBandwidth, UIEarlfcn a PathLossModel), musí být plně implementovány s reálnými hodnotami atributů. Dosažené výstupy jsou shrnuty v Příloze B.

DECLARATION

I declare that I have written the Bachelor's Thesis titled "Implementace komunikačních technologií NB-IoT a LTE-M v simulačním nástroji NS-3" independently, under the guidance of the advisor and using exclusively the technical references and other sources of information cited in the thesis and listed in the comprehensive bibliography at the end of the thesis.

As the author I furthermore declare that, with respect to the creation of this Bachelor's Thesis, I have not infringed any copyright or violated anyone's personal and/or ownership rights. In this context, I am fully aware of the consequences of breaking Regulation § 11 of the Copyright Act No. 121/2000 Coll. of the Czech Republic, as amended, and of any breach of rights related to intellectual property or introduced within amendments to relevant Acts such as the Intellectual Property Act or the Criminal Code, Act No. 40/2009 Coll., Section 2, Head VI, Part 4.

Brno

.....

author's signature

ACKNOWLEDGEMENT

First of all am grateful to God for the wellbeing and good health necessary to complete this book.

I wish to express my sincere thanks to the supervisor of this bachelors thesis, Ing. Pavel Mašek Ph.D. I am extremely thankful and indebted to him for sharing expertise, resources, sincere and valuable guidance and encouragement extended to me. He has always been by my side throughout the entire work.

I am also grateful to doc. Ing. Petr Číka Ph.D., Faculty Secretary, for keeping me up to date with information.

I would also like take this opportunity to express gratitude to prof. Ing. Jiří Mišurec, CSc., the Board Chairperson for the assistance, both direct and indirect.

And finally, I'd like to thank everyone who contributed to the success of this bachelor thesis and supported me through advice and encouragements. I will always be indebted to you all.

Brno

.....

author's signature

Contents

INTRODUCTION	12
1 THE INTERNET OF THINGS	13
1.1 Current trends in IoT	13
1.2 The basic principle and the scope of IoT	13
1.3 Industrial IoT, Industry 4.0	14
2 LOW POWER WIDE AREA NETWORKS	18
2.1 M2M communication via the LPWAN	18
2.2 Standardization activities	20
2.3 Long Range Wide Area Network	20
2.4 Sigfox	22
2.4.1 Ultra-Narrow Band	22
2.4.2 Spectrum and data rate	23
2.4.3 Random access	24
2.4.4 Bi-directional small messages	24
2.4.5 Network architecture overview	24
2.5 Long Term Evolution for Machines	25
2.5.1 An overview	25
2.5.2 LTE Optimization to support MTC	26
2.5.3 LTE Cat. 0	27
2.6 Narrow Band Internet of Things	27
2.6.1 General description	27
2.6.2 3GPP LTE NB-IoT Release and enhancements	28
2.6.3 Physical Channel	29
2.6.4 Core Network	30
2.6.5 Access Network	30
2.6.6 Spectrum, Frequency Bands and Operation Modes	31
2.6.7 Downlink	34
2.6.8 Uplink	38
2.6.9 Performance of NB-IoT	39
2.6.10 Reliability	39
2.6.11 Power Control	40
2.6.12 Future perspectives	40

3	IMPLEMENTATION OF NB-IoT SCENARIO	42
3.1	General description	42
3.2	Network Simulator 3	43
3.2.1	Architecture	43
3.2.2	LTE-EPC Network Simulator	43
3.2.3	LENA application in NS-3 environment	44
3.2.4	Used modules	46
3.3	Proposed changes in NS-3 towards NB-IoT implementation	53
4	SIMULATION AND RESULTS	55
4.1	Description of created communication scenario	55
4.2	Results and lessons learned	56
4.2.1	Flow of data in the simulation	56
5	CONCLUSIONS	60
	Bibliography	61
	List of symbols, physical constants and abbreviations	66
	List of appendices	69
A	Codes Used	70
A.1	Mobility	70
A.2	SRS	70
A.3	CosineAntennaModel	70
A.4	UEs Random Position Allocation	71
A.5	UDP Protocol code used	71
A.6	TCP Code	72
B	QoS	74
B.1	Output for 500 UEs	74
B.2	Control sim for 20 UEs	74
C	Content of the CD included	76

List of Figures

1.1	Mobile Data Traffic Growth in 2016.	15
1.2	Reference architecture for IoT-based smart factory	16
2.1	Comparison of LPWAN technologies.	18
2.2	Flat Architecture of Sigfox network.	22
2.3	Sigfox technology based on Ultra-Narrow Band.	23
2.4	High-level architecture of the Sigfox network.	25
2.5	LTE/LTE-M Network Architecture.	26
2.6	Network for the NB-IoT data transmission and reception.	31
2.7	Network architecture towards the air–interface.	32
2.8	NB-IoT operation modes.	33
2.9	Mapping of the transport channels to the physical channels.	35
2.10	Resource grid for one slot. There are 12 subcarriers for the 180 kHz bandwidth	36
2.11	Frame structure for NB-IoT for DL and UL with 15 kHz subcarrier spacing.	37
2.12	Basic mapping of reference signals to the resource elements. NSR transmitted by; port 0 are black and port 1 are grey.	37
2.13	Physical and transport channels mapping.	38
2.14	(a) Device-originated calls. (b) Network-originated calls	41
3.1	LTE topology created in LENA.	44
3.2	LTE-EPC data plane protocol stack.	45
3.3	Error from additional attributes.	54
4.1	Topology of the scenario for simulation.	55
4.2	Simplified NB-IoT network topology.	56
4.3	Topology in NetAnim.	57
B.1	500 UEs	74
B.2	20 UEs.	75

List of Tables

2.1	Comparisons of LPWAN technologies	19
2.2	EU 868 MHz Band frequency channels and regulations	21
2.3	Subbands for Sigfox and their applications in the European 868 MHz ISM Band.	23
2.4	A list of some payload size examples.	24
2.5	LTE UE category comparison table	27
2.6	Receiver sensitivity and minimum transmission bandwidth used by LPWAN technologies.	33
2.7	NB-IoT Frequency Bands in Release 13.	34
4.1	LTE UE category comparison table	59

INTRODUCTION

This Bachelor's thesis begins with an introduction to the world of Internet of Things (IoT), how it is changing our life: how we, as humans, interact among ourselves, Human to Human (H2H) or how machines start getting smarter eventually communicating with us Machine to Human (M2H) or with each other Machine to Machine (M2M).

The next objective of the bachelor thesis is describe how User Equipments (UEs), nodes or end devices transmit data towards a remote server and vice versa; the language of communication, the rate of transfer of data to achieve a desired objective. The medium of communications and the technologies used to enable this communications are also discussed.

Discussions shall be made on Low Power Wide Area, LPWA, which is an umbrella for a variety of technologies: the Narrow Band Internet of Things (NB-IoT), Long Range Wide Area Network (LoRaWAN) and Sigfox among others. Later in the Section 2.6, a more detailed view is given to NB-IoT. Its general description is laid out. The 3GPP release 13 and 14 are discussed with the changes that affect the NB-IoT technology, the network structure i.e., the core network (the user plane and the control plane) and the access network, the spectrum and frequency bands used, the downlink (DL) and the uplink (UL) frame and slot structures, power control, reliability among others.

Going further, different network simulators are compared and discussed. More emphasis is put on Network Simulator 3 (NS-3). The LENA module is chosen for this simulation. The Long Term Evolution (LTE) - Evolved Packet Core (EPC) or in short LTE-EPC Network Simulator (LENA), a module in NS-3 is also discussed. This module can be modified to accommodate the NB-IoT. The proposed changes that are necessary to implement in the LENA module towards NB-IoT are described including used modules such as the Mobility Module, Propagation Module, Flow Monitor Module, and Spectrum Module.

Finally in the simulation results, a description of the created scenario in NS-3 simulator for NB-IoT is given. A number of User Equipments is connected to eNodes which connect to Packet Data Gateway (P-GW) communicate with the remote host via Transport Control Protocol (TCP) and User Datagram Protocol (UDP). The simulation is carried out and the results analysed in NetAnim and Wireshark. Lessons learned and possible future changes and implementations are suggested in Section 4.2 and in Chapter 5.

1 THE INTERNET OF THINGS

1.1 Current trends in IoT

With the increasing pervasiveness of computers in our daily lives, the Internet of Things (IoT), has been growing so rapidly in the past few years from being a distant technology that laid far beyond the horizons to a real-world deployment [1].

The IoT is a set of products, services and processes that virtualizes the real-world things for digital processing [2]. In short, it refers to interconnection and exchange of data among devices [3]. Its outcome is the digital representation of the real world that can interact with digital systems and applications [2]. It has decisively developed in the recent decades: starting from the legacy 1930 technology of radio frequency identifier (RFID) revolutionizing the wireless sensor networks (WSNs) of mid-1990s [4].

Today, it is demanded that information is transferred across all sorts of things in different volumes and rates. This is analogous to the human body which has the senses of feel, hear, vision, taste and smell. In the “things” world, there are cameras for vision, microphones for sound and sensors for touch, temperature and distance of approach of physical objects. All these end devices can feed these data into servers where decisions are made (sounding an alarm, switching off heater etc.).

The IoT is being approached by researchers from academia and industry, as well as business, government agencies and cities. This technology is being explored from three main perspectives: scientific theory, engineering design and the user experience [5].

While the current Internet already has a vast effect in the lives of many people and that of business and organizations, this penetration will increase in scope and depth due to IoT. New applications fields will be opened up. There will also be an increased penetration of processes, environment and actions by Information and Communications Technology (ICT). The range of “things” that will be sensed, tracked, and manipulated by ICT will truly be overwhelming [2].

1.2 The basic principle and the scope of IoT

IoT is, in principle, about attaching a varying amount of identity, interaction and inferences¹ to objects. Examples of identities can be tags, shapes and forms or IP addresses and interactions include acting, sensing and physical connectivity [2].

¹Conclusions based on results, eg. when an alarm rings, inference can be a burglar, fire or any other attention attracting phenomenon. In this case a security or safety personnel may check the camera

The connectivity is wide spread. It is not just between devices, but also between materials, phenomena, space, human actions, processes, concepts, data repositories et cetera.

This interactions will immensely depend on how smart Machine to Machine (M2M) communication becomes. M2M is defined as data communication among devices without the need for human interaction [6]. It can be achieved through a centralized or a peer-to-peer model. M2M applications are widely used in security, car tracking, smart grid, payment, and remote maintenance and monitoring. It is estimated that 50 billion connected devices will be deployed by 2020 [6] and the total M2M revenue is expected to grow from \$200 billion in 2011 to \$1.2 trillion in 2022 [7]. It has been estimated that, by the year 2021, nearly three-quarters of all devices connected to the mobile network will be “smart” devices [8].

This sharp increase in Machine Type Communication (MTC) is a challenge on cellular operators to support MTC without compromising on the existing quality of services for the already established H2H type communication [9]. Two technologies, the LTE-M (Long Term Evolution for Machine Type Communication) and NB-IoT (Narrow Band Internet of Things) have been standardized by the 3rd Generation Partnership Project (3GPP).

Global mobile network traffic grew significantly in the last few years and by 63 percent in 2016 [8] with most of the growth registered in developing parts of the world such as Middle East and Africa, [8] Fig. 1.1. Who knows in the nearest future, the world will become all interconnected, just as a human body: with the nerves being the optical fibres carrying information in the speed of light. It becomes aware of anything happening anywhere and respond to it accordingly.

1.3 Industrial IoT, Industry 4.0

The IoT is the next technological revolution. This gave rise to the Industry 4.0, the fourth industrial revolution. A brief time-line of the industrial revolution with emphasis of the major events is:

1. **Industry 1.0 – 1765.** This witnessed the emergence of mechanization, a process that replaced agriculture as an industry. The primary source of energy being coal to fuel the steam engine.
2. **Industry 2.0 – 1870.** This was typically the advancements of technology that initiated the emergence of a new source of energy: electricity, gas and oil which gave birth to the combustion engine. Chemical synthesis also had so much to play (synthetic fabric, dye and fertilizer). The invention of the telegram and telephone. Transport methods, the auto-mobile and the plane.

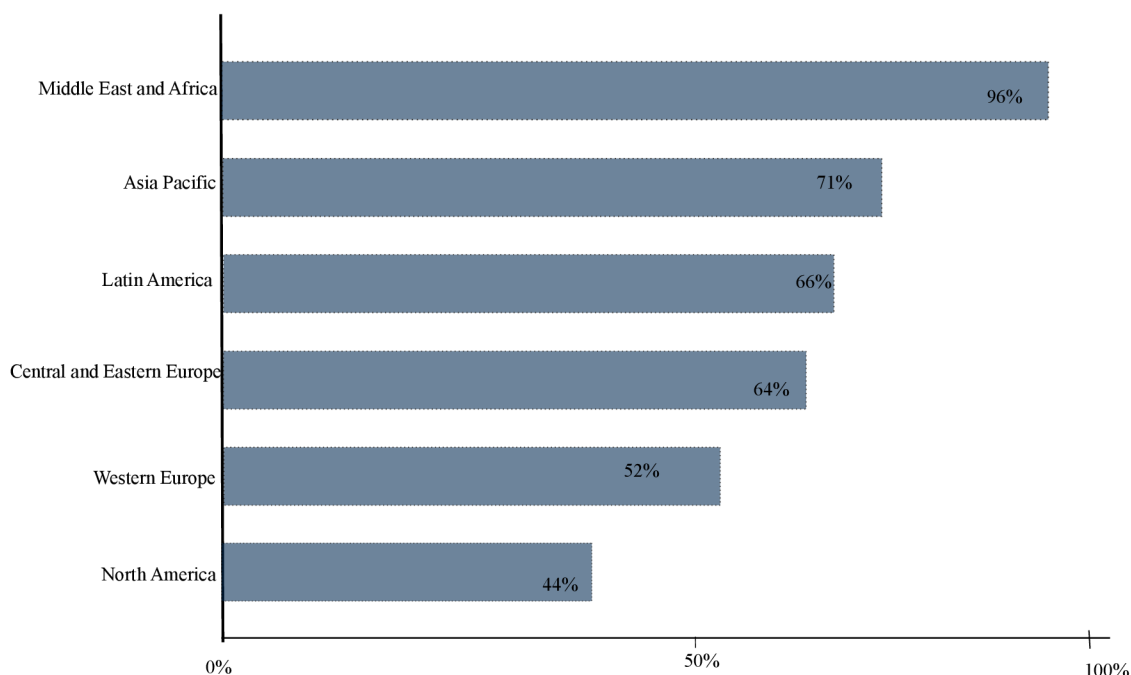

Fig. 1.1: Mobile Data Traffic Growth in 2016.

3. **Industry 3.0 – 1969.** The nuclear energy. The rise of electronics - transistor and microprocessors as well as telecommunications and computers. Biotechnology. High level of automation in the industry
4. **Industry 4.0 - Today.** In summary, digitalization and the Internet.

Industry 4.0 is the first industry revolution rooted in a new technological phenomenon - **digitalization** rather than the emergence of a new type of energy. The digitalization process enables us to build a virtual world from which the real world can be steered.

The Industrial internet of things applies IoT technology to industrial sector. It encompasses machine learning and Big Data by exploiting data sensors and M2M which have for many years existed in the industry.

The basic principle of Industry 4.0 is the core of IoT and smart manufacturing: work in progress products, components and production machines will collect and share data in real time [10]. This will result into a shift from centralized factory control systems to decentralized intelligence.

Fig. 1.2 is a presentation of a reference architecture for IoT-based smart factory in industry 4.0. The following are the several sets of technologies and perspectives included:

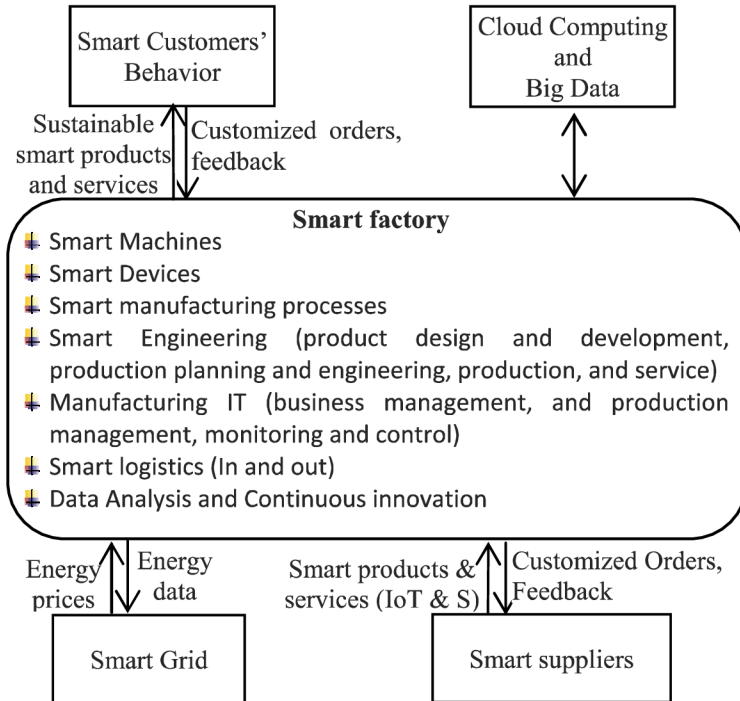

Fig. 1.2: Reference architecture for IoT-based smart factory [10]

- **Smart Machines:** It includes M2M communication where machines communicate with each other without human involvement, machines communicating with humans.
- **Smart Devices:** Includes connecting devices such as field devices, mobile devices and, operating devices etc in the factory.
- **Smart Engineering:** includes dynamic, automated, real-time and efficient process communication for the management and control of a highly dynamic manufacturing environment enabled by IoT.
- **Manufacturing IT:** includes software applications used by one or more business supporting mobile technology leads to shrink the time between problems occurs and make the efficient decisions.

Many initiatives such as Safe Community Awareness and Alerting Network (SCALE), a cyber-physical system (CPS) leverage the IoT to extend a smarter home and infrastructure. The aim is at improving the safety of residents by using modern connected devices and computer systems. This is particularly to low-income earners and elderly who, most times, do not have access to advanced technologies such as home security, computers and smart phones with Internet access [1]. Deployments using LPWAN can potentially reduce the cost of services which is suitable for the target group of users [1].

The cognitive radio-based sensor network (CRSN) for Smart Grids (SG) is used for monitoring and control purpose in various components of the SG. It has a wide range of applications ranging from generation, transmission towards the customers including monitoring of utility assets. This enables customers to transfer, monitor, predict and control energy usage in a cost efficient manner and effectively [11]. LPWAN technologies like: LoRaWAN, Sigfox, NB-IoT, Long Term Evolution for Machine (LTE-M1) and LTE Category one (LTE Cat-1) are promising access wireless technologies for a WAN for delivering SG applications control and data [11].

2 LOW POWER WIDE AREA NETWORKS

2.1 M2M communication via the LPWAN

One major challenge that faces the IoT is the fact that, as long as they transmit data, User Equipment (UEs) such as sensors operated on battery have to stay charged. Low Power Wide Area Network (LPWAN), as their names already suggest, are wireless technologies whose major objectives, among others, is to maximize life of a battery of an end device. The power consumption of UEs in LPWAN is being maximized by:

- Allowing sleep times: Here, the main energy consumers, radio transceiver and micro controller, alternate between idle and active (Transmitting, Receiving, Idle, Sleep) [12]. They use known power consumption patterns and timing constrains predefined by the Media Access Control (MAC) layers.
- Bandwidth/data rate: Bandwidth is used to determine the amount of data being transferred (i.e., bit rate) usually per second [13]. It is the spectrum range in Hertz that can be used by a system to transfer digital information (in a digital communication) [13]. In LoRaWAN, the data rate is selected by trading-off between communication range and the duration of the messages [14].

SIGFOX		Wi-Fi HaLow	
Band: SubGHz ISM Carrier: 868 MHz Rate: 100 bps uplink 600 bps doanlink	Devices in cell: up to millions Chipset price: 2-5 EUR	Band: SubGHz ISM Carrier: 868 MHz Rate: 150-7 800*kbps <i>*single spatial stream</i>	Devices in cell: up to 8192 Chipset price: 4-8 EUR
Tx power: 14dBm Link budget: 156dB Range: over 30 km	Features: 1) Single MCSs 2) Multi-channel ALOHA MAC	Tx power: up to 14dBm Link budget: 72-115dB Range: up to 1 km	Features: 1) Over 30 MCSs 2) OFDM
LoRaWAN		NB-IoT	
Band: SubGHz ISM Carrier: 433/868 MHz Rate: 293-50 000 bps uplink/downlink	Devices in cell: up to millions Chipset price: 2-5 EUR	Band: licebced UHF Carrier: 0.7-2.1GHz Rate: 310-250K bps uplink 440-226 700bps downlink	Devices in cell: up to 8192 Chipset price: 2-5 EUR
Tx power: up to 20 dBm Link budget: 117-156 dB Range: over 30 km	Features: 1) 8 MCSs 2) Multi-channel ALOHA MAC	Tx power: up to 23 dBm Link budget: < 164 dB Range: over 30 km	Features: 1) Over 7 MCSs 2) OFDM/SC-FDMA

Fig. 2.1: Comparison of LPWAN technologies.

In a typical M2M network, the uplink (UL) traffic originates from the wireless devices, destines to the access point (AP) or the sink node, or the base station and

is heavier than the downlink (DL) traffic. This is caused by the fact that the current M2M communication applications are mostly used for data gathering. Thus, there is a lot of focus on the solutions for handling the UL traffic dominated characteristic because ultra-low power operation is a key requirement to cover the opportunity provided by battery-powered IoT/M2M devices. A desirable lifetime of about 10 or more years with AA or coin battery would reduce the cost [13].

There is a wide range of communication technologies for IoT. Worth mentioning are the Low Power Wide Area Network technologies that will be discussed in more depth in this chapter, with an emphasis on Narrow-band Internet of Things (NB-IoT). They include: Long Range Wide Area Network (LoRaWAN), Sigfox, the Narrow Band Internet of Things (NB-IoT), Long Term Evolution for Machine Type Communication (LTE-M) and Extended Coverage – GSM – Internet of Things (EC-GSM-IoT).

In the LPWAN space, the most prominent ones are: LoRa, Sigfox and NB-IoT as shown in Fig. 2.1 [15].

Technology	SIGFOX UNB	LoRa	3GPP	
			LTE-M	NB-IoT
Receiver sensitivity	-147 dBm	-137 dBm	-132 dBm	-137 dBm
Frequency band	Sub-GHz ISM	Sub-GHz ISM	Licensed	Licensed
Minimum transmission bandwidth	100 Hz, 600 Hz	125 kHz	180 kHz	3.75 kHz
Fully bi-directional	No	Yes	Yes	Yes
Modulation	D-BPSK	LoRa modulation, ¹ GFSK	BPSK, QPSK, 16QAM, 64QAM	$\pi/2$ -BPSK, $\pi/4$ -QPSK
Medium access control (MAC)	Unslotted ALOHA	Unslotted ALOHA	SC-FDMA	SC-FDMA
Data rate	100 b/s	0.3-38.4 kb/s	Up to 1000 kb/s	Up to 100 kb/s
Over the air upgrade	No	Yes	Yes	Yes
Roaming	Yes	Yes	Yes	Yes
Standard	No	LoRaWAN ²	LTE (Release 12)	LTE (Release 13)

¹ A proprietary modulation scheme that is a derivative of Chirp Spread Spectrum.
² MAC layer only.

Tab. 2.1: Comparisons of LPWAN technologies [16].

Fig. 2.1 shows detailed comparison between the main LPWAN technologies [16].

2.2 Standardization activities

The technological implementation of IoT should ideally rely on standardization. International standards are needed to avoid regional fragmentation in order to allow world wide use of products and solutions. The standardization of a reference architecture model is also required to achieve the goal of compatibility and interoperability across industrial domains, however without compromising on security [2]. The IoT still suffers from the limited interoperability in the present form as the IoT becomes increasingly interconnected and massive [4]. The standardization should however keep pace with requirements and evolution in the area of IoT. For example, there is need for standards in the areas of:

- **Cross domain architectural frameworks for IoT**, e.g., developing traffic control systems for smart cities requires the suitable combination of the traffic optimization system to optimize the overall throughput while taking account and giving strict priority to emergency services and police where and when they are needed [2].
- **Semantic interoperability** between data from different domains enabling integrated cross domain services, the example above also requires standardization of data over the whole value chain [2].

2.3 Long Range Wide Area Network

LoRa which stands for Long Range Radio, is a wireless technology for NB-IoT. It is designed to allow low-powered devices to communicate with Internet-connected applications over long range wireless connections [17].

LoRaWAN utilizes the industrial, scientific and medicine (ISM) radio bands which are unlicensed. Of the available ISM bands, LoRaWAN uses 683-870 MHz and 433 MHz in Europe. It uses different bands in other parts of the world such as US, Australia, China ...

The LoRaWAN is laid out in a star topology in which a device (an end device in LoRa terminology) is connected to a central server via gateways (or base stations) [15]. It also supports, for maximum battery saving, end-devices with a device-originated calls only. In addition to that, LoRa supports network-oriented transmission mode in which case end devices periodically wake up to receive paging as LTE user equipments (UE) in traditional cellular network. For paging to be facilitated, a beacon signal is transmitted by a LoRa gateway that allows an end-device to synchronize to the network and look for downlink transmission in the predetermined windows [15].

LoRaWAN is based on LoRa modulation which is Chirp¹ Spread Spectrum (CSS). LoRaWAN supports LoRa spreading factors 7 to 12 [17].

Going further, LoRaWAN defines three classes of nodes: A, B and C, where class A has the lowest complexity and energy usage. Only in a receive window can a class A device receive a downlink message. After the transmission in the uplink, there are two receive windows. The class A capability must be implemented by all LoRaWAN devices [15]. Tab. 2.2 is according to the regulations.

F _c [MHz]	LoRa Mote Transmit power [dBm]	Regulations	
		Max. Tx power [dBm]	Spectrum access
868.100	14	14	1 % or LBT AFA★
868.300	14	14	1 % or LBT AFA
868.50	14	14	1 % or LBT AFA
868.850	14	14	0.1% or LBT AFA
869.050	14	14	0.1% or LBT AFA
868.525	14	27	10% or LBT AFA

★Listen before Talk Adaptive Frequency Agility (LBT AFA)

Tab. 2.2: EU 868 MHz Band frequency channels and regulations [18].

The ISM are free bands are subject to regulations in terms of maximum transmit power, duty cycle and bandwidth. The radio emissions of the end-device is also limited by a duty cycling mechanism called the aggregated duty cycle which they obey. The maximum duty cycle of 100% corresponds to the device being allowed transmission at any time, but still in accordance with the regulatory duty cycling. The LoRaWAN protocols are defined by the LoRa Alliance and formalized in the LoRaWAN Specification [19].

LoRaWAN defines a MAC layer protocol to enable LPWAN [19]. In a star topology, a gateway serves several nodes and relays messages to a central server. In LoRaWAN, an adaptive data rate (ADR), scheme is implemented in which a network server is allowed to select both the channels to be used by each node and the data rate [19].

¹Chirps are essentially symbols

Security wise, LoRaWAN knows three distinct 128-bit security keys. This feature provides multiple layers of encryption in LoRaWAN.

2.4 Sigfox

Sigfox is considered both as a service provider and as a IoT protocol technology. It “listens” to billions of objects broadcasting data, without the need to establish and maintain network connection. It offers a software based communication solution, where all the network and computing complexity is managed in the Cloud, rather than on the device [20]. In this case, energy consumption and the costs of the connected devices are drastically reduced.

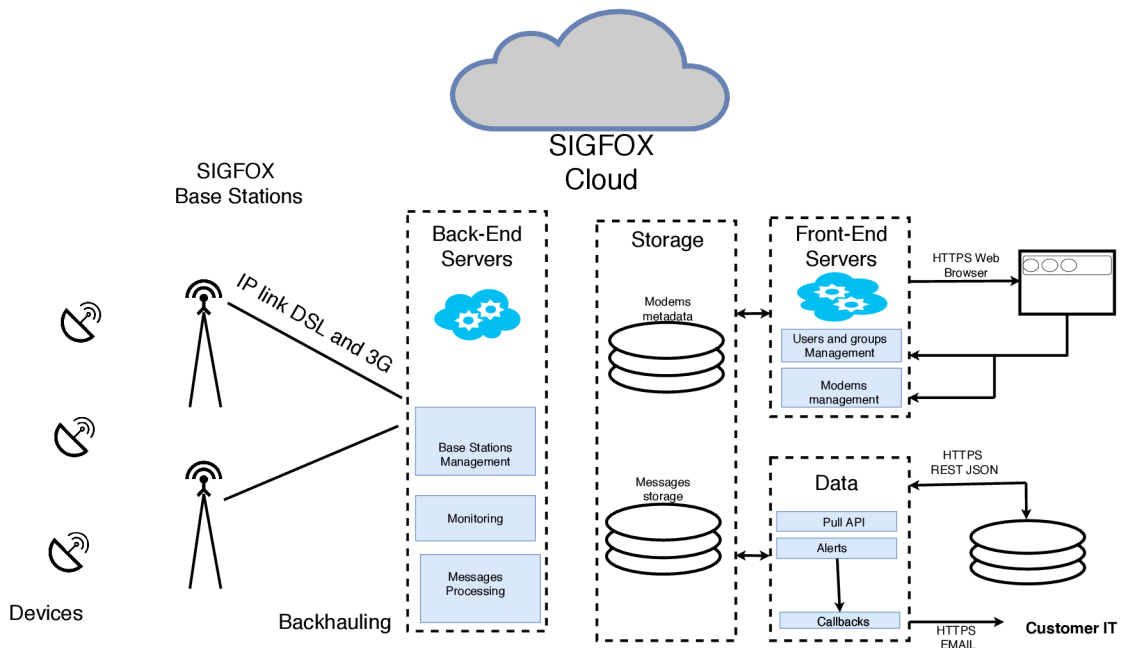

Fig. 2.2: Flat Architecture of Sigfox network [21].

2.4.1 Ultra-Narrow Band

Sigfox uses 192 kHz to exchange messages over the air. It uses the Ultra-Narrow Band (UNB) modulation technology.

Category	Frequency [MHz]	Standardized application	Max ERP	Duty cycle	Potential devices
	863.00 - 870.00	Non-specific use	25 mW	0.1 % or LBT+AFA	For narrow- and wideband devices including spread spectrum techniques
Audio	863.00 - 865.00	Radio microphones	10 mW	None	Microphones, wireless audio, and streaming E.g. baby alarms and wireless headphones
	864.80 - 865.00	Wireless audio	10 mW	None	
RFID	865.00 - 868.00	RFID	2 W	None	RFID readers and tags
Alarms etc.	868.00 - 868.60	Non-specific use	25 mW	1 % or LBT+AFA	Wireless-M, Z-Wave, IEEE 802.15.4 technologies, <i>LoRa</i> , <i>SigFox</i> Fire and intruder Industrial applications, wireless-M Telecare (self/automatic triggered alarms) Fire and intruder Fire and intruder Industrial data links & communication devices, Wireless-M, <i>LoRa</i> , <i>SigFox</i> Fire and intruder
	868.60 - 868.70	Alarms	10 mW	1 %	
	868.70 - 869.20	Non-specific use	25 mW	0.1 % or LBT+AFA	
	869.20 - 869.25	Social alarms	10 mW	0.1 %	
	869.25 - 869.30	Alarms	10 mW	0.1 %	
	869.30 - 869.40	Alarms	10 mW	1 %	
	869.40 - 869.65	Non-specific use	500 mW	10 % or LBT+AFA	
	869.65 - 869.70	Alarms	25 mW	10 %	
	869.70 - 870.00	Non-			

Tab. 2.3: Subbands and their applications in the European 868 MHz ISM Band [21].

2.4.2 Spectrum and data rate

Sigfox is an UNB technology operating in the 868 MHz frequency band in Europe and 915 MHz in the United States. Each message is 100 Hz wide and transferred at 100 or 600 bits per second data rate 2.3, depending on the region. Hence, long distances can be achieved while being very robust against the noise [20].

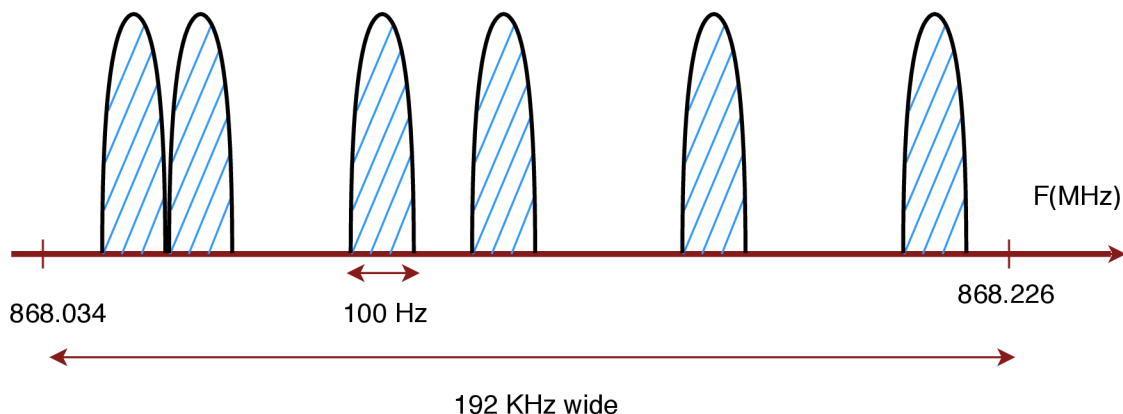

Fig. 2.3: Sigfox technology based on Ultra-Narrow Band [21].

Using the UNB modulation, it operates in the 20 kHz of publicly available band. In Europe the physical layer (PHY) rates are 100 bps for a 100 Hz bandwidth and 1000 bps for a 1 kHz bandwidth.

An uplink message in Sigfox has up to 12-bytes payload and takes an average of 2 s over the air to reach the base station [21]. A Sigfox frame uses 26 bytes in total for a 12-byte data payload. Sigfox has a limited number of messages per day [21] (140 messages per day).

There is a multitude of devices within the 868 MHz ISM band and the expected evolution in terms of number of devices. LoRaWAN and Sigfox rely on duty cycle access method and thus the transmissions may be subject to interference from growing number of devices, which can cause a degraded Signal-to-Noise-and-Interference-Ratio (SINR) and in the worse case packet loss. Also, other devices working in ISM band can influence the transmissions.

2.4.3 Random access

This is one of the key features to achieve a high quality of service. The transmission is unsynchronized between the network devices. The device sends a message on a random frequency and then sends 2 replicas (or 3 in some cases) on different frequencies and time [21]. This is called “time and frequency diversity”.

The Sigfox base stations monitor the full 192 kHz spectrum and look for the UNB signals to demodulate.

2.4.4 Bi-directional small messages

The downlink message is initiated by the object. There is a delay of 20 seconds between the first frame transmitted and the reception window which lasts for a maximum of 25 seconds. The downlink frequency is the frequency of the first uplink message plus a known delta [21].

Sigfox designed a communication protocol for small messages to address the cost and autonomy constraints of remote objects. The size of the message is from 0 to 12 bytes. A 12 byte payload is enough for most use-cases to transfer sensor data, the status of an event such as an alert, GPS coordinates or even application data.

Some payload size examples are listed in Tab. 2.4 .

GPS Coordinates	6 bytes
Temperature	2 bytes
Speed reporting	1 byte
Object status	1 byte
«Keep alive» payload	0 byte

Tab. 2.4: A list of some payload size examples [21].

2.4.5 Network architecture overview

The Sigfox network has a horizontal and a thin architecture composed of 2 main layers.

- The network equipment layer basically consists of base stations and other elements such as antennas that receive messages from devices and transferring them to the Sigfox Support Systems.
- The Sigfox Support System is the second layer constituting the core network in charge of message processing and sending them through callbacks to the consumer system. The Sigfox Support Layer also provides an entry point to the different actors of the eco-system such as Sigfox, Sigfox operators, channels and end-customer to interact with the system through web care interfaces or APIs.

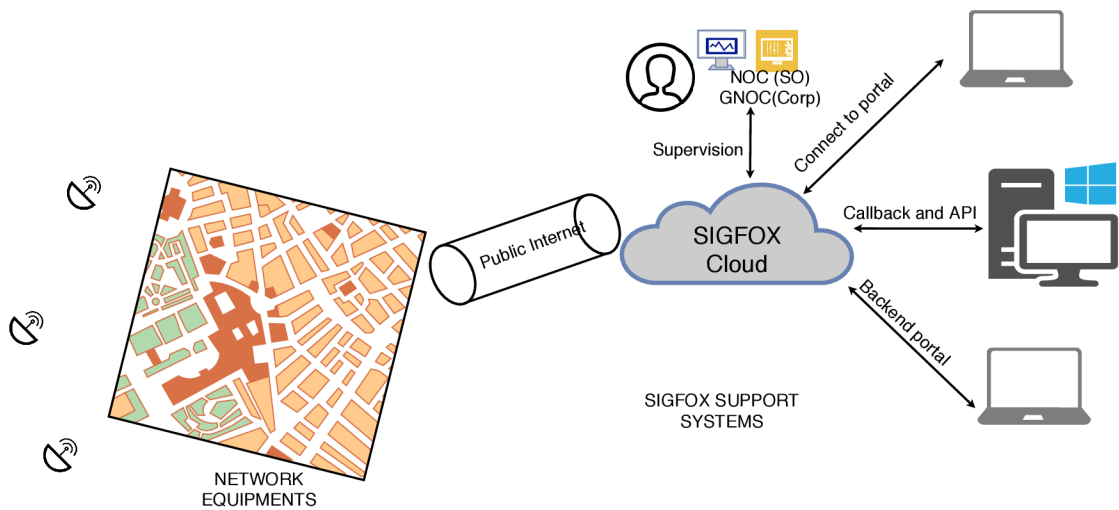

Fig. 2.4: High-level architecture of the Sigfox network [21].

2.5 Long Term Evolution for Machines

2.5.1 An overview

The IoT will bring many devices (in billions) that are inter-connected using cellular networks. Long Term Evolution, LTE, networks are being deployed worldwide and will remain in place for the foreseeable future [3]. LTE, however, was designed for high data-rate broadband services and therefore not optimized for M2M data transfers which are typically low data rate. The M2M features were added to LTE in release 12 [3]. The features added are aimed at extending the LTE services to machines for IoT communications. Fig. 2.5 shows the structure of an LTE-M network architecture.

“”

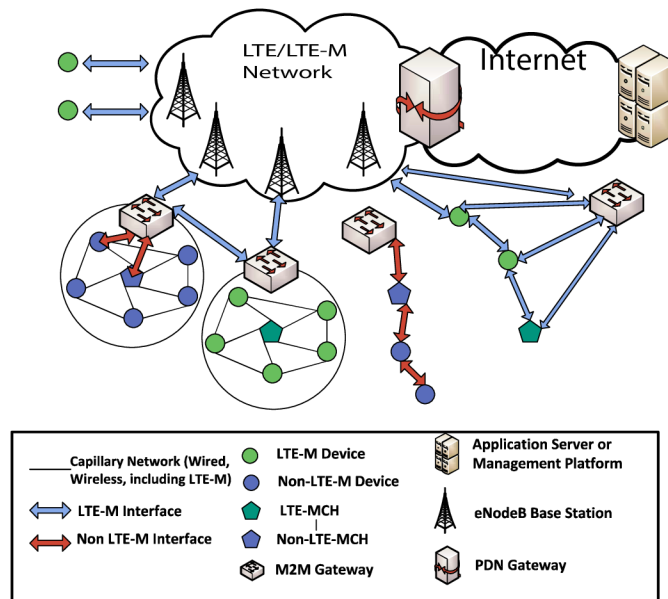

Fig. 2.5: LTE/LTE-M Network Architecture.

2.5.2 LTE Optimization to support MTC

According to [22] published on July 23, 2015, 3GPP has completed a study on optimizing LTE for machine type communication to provide devices that are cost competitive with the existing 2G equipment [23]. Machine Type Communication (MTC) devices will be connected through an LTE-M backbone integrated in LTE network without hindering mobile network performance. The minimum requirements that 3GPP has set with the publication “Study on the provision of low-cost MTC User Equipment based on LTE” will [22]:

- Match 2G data rates.
- Ensure that service coverage footprint is as good as 2G.
- Re-use the existing LTE/SAE network architecture.
- Ensure good radio frequency coexistence with legacy LTE.
- Improve on 2G average spectrum efficiency for low data rate MTC traffic.
- Target operation of low-cost MTC UEs and legacy LTE UEs on the same carrier.
- Support limited mobility and low power consumption modules.
- Use existing LTE base station hardware.
- Proceed in terms of changes to the 3GPP Rel-10 version of the specifications.
- Consider optimizations for both FDD and TDD mode.

	Rel-8 Cat-4	Rel-8 Cat-1	Rel-12 Cat-0	Rel-13
Downlink peak rate	150 Mbps	10 Mbps	1 Mbps	~200 kbps
Uplink peak rate	50 Mbps	5 Mbps	1 Mbps	~200 kbps
Max number of downlink spatial layers	2	1	1	1
Number of UE RF receiver chain	2	2	1	1
Duplex mode	Full duplex	Full duplex	Half duplex (opt)	Half duplex (opt)
UE receive bandwidth	20 MHz	20 MHz	20 MHz	1.4 MHz
Maximum user transmit power	~23 dBm	~23 dBm	~23 dBm	~20 dBm
Modem complexity relative to Cat-1	125%	100%	50%	25%

Tab. 2.5: LTE UE category comparison table [24].

2.5.3 LTE Cat. 0

The new UE Category '0' was introduced in Release 12 of 3GPP. This sets the requirements to reduce complexity and power consumption. The Release 13 brings in [22]:

- 75% modem complexity reduction compared to Cat 1.
- Reduce UE receive bandwidth to 1.4 MHz.
- 10+ years of battery life.
- 15-20 dB coverage enhancement.

The properties of the different releases categories of LTE-M are compared in Fig. 2.5. The figure also includes a comparison of the modem complexity of each release relative to Cat. 1 of Release 8.

2.6 Narrow Band Internet of Things

2.6.1 General description

The IoT is the ongoing paradigm shift of communication. In the society that is networked, all things that benefit from connection can and will be connected [25]. The major challenge lies in the fact that the connection will not just be between humans (H2H) but also between machines (M2M or MTC). Unlike communications that are generated by humans, the key requirement for MTC is the importance of enabling economical wireless connectivity for massive numbers of devices [25]. Not only must the cost of the devices be low, the network capacity be sufficient, and the

device battery life be long enough to make charging or battery replacement obsolete, but coverage should also be improved to reach devices in challenging locations [25].

There is a large number of capabilities of MTC. Devices for fleet tracking, for examples, have to evaluate a small amount of data while performing many handovers. On the other hand, stationary devices such as surveillance cameras have to deliver large data in UL without any handovers. Devices for meter reading irregularly send only just a small amount delay insensitive data due to the large period they use in transmission. However, the number of these devices can be quite large if a dense urban scenario is considered [26].

2.6.2 3GPP LTE NB-IoT Release and enhancements

Release 13

To provide massive MTC connectivity, NB-IoT was standardized together with LTE-M in Release 13 of 3GPP. It was standardized with the following enhancements [23]:

- agreement on NB-IoT positioning,
- support for Multicast,
- power consumption and latency reduction,
- non-Anchor PRB enhancements,
- mobility and service continuity enhancements,
- New Power Class(es).

Release 14

For further improvements of the user experience and cater for more use cases, several enhancements and functionalities are introduced for NB-IoT in 3GPP LTE Release 14. The new enhancement features are briefly discussed below [25]:

- **Positioning:** Many IoT use cases require and/or benefit from location information, making positioning an important dimension of the IoT. Release 13 only supports basic positioning feature using cell identity (CID). Advanced positioning techniques are introduced in Release 14.

The standardization efforts of Release 14 are to:

- Develop support for the feature of observed time difference of arrival (OTDOA) for NB-IoT.
- Complete UE measurement requirements for enhanced CID.
- **Multicast:** Multicast is group communication, where data is addressed to a group of users in a single transmission. In Release 14, multimedia broadcast messages (MMBM) is supported through a single-cell point-to-multipoint (SC-PtM). In SC-PtM, the single-cell MBMS control (SC-MCCH) and single-cell

MBMS traffic channel are logical channel that carry control and data traffic respectively.

- **New UE power output class:** the objective is to achieve smaller form factor, lower device power consumption and lower device costs compared to the 20 dBm devices in Release 13.
- More enhancements on the system and UE throughput, Multi-Carrier enhancements, non linear carrier operation, mobility and other services.

In order to fulfil above mentioned requirements, most advanced and even basic features of earlier LTE releases (8/9) are not supported. One outstanding example is the lack of handover for UEs when they are in the connected state. In the idle state, there is only cell reselection which is restricted to NB-IoT technology. As there is not interaction with other radio technologies, also the associated features are not supported [26]. Among the advanced LTE features not supported by NB-IoT is Dual Connectivity, Carrier Aggregation and device-to-device service [26]. In addition, since NB-IoT is not used for delay sensitive data packets, there is no concept of Quality of Service, QoS. In result, all services that require a guaranteed bit rate such as real time IP Multimedia Subsystems (IMS) are not offered in NB-IoT.

It is possible to deploy NB-IoT in a narrow system bandwidth (i.e., 200 kHz. 180 kHz in case of Vodafone's mobile network in Czech Republic). The technology also provides enhanced coverage of up to 164 dB maximum coupling loss (MCL), is energy-efficient to provide long battery life [25]. It is apparent that the NB-IoT is a technology that may be preferred for massive deployment in latency independent, high density and, because of its excellent signal propagation to hard-to-reach indoor places such as basements, it is suitable for indoor deployments.

2.6.3 Physical Channel

With respect to Universal Telecommunications Systems, UTS, the LTE PHY layer employs new technologies in mobile communication. The physical layer allows efficient transmission of both data and control information between the User Equipments, UEs and eNodeBs. The LTE frame structure depends on the duplexing mode. The following are defined:

1. Type 1 frame structure for Frequency Division Duplexing (FDD),
2. Type 2 frame structure for Time Division Duplexing (TDD).

In FDD (type 1), both the UL and the DL have a 10 ms time duration. Each frame is split into 10 subframes each of 1 ms and each subframe is composed of two slots of 0.5 ms resulting in 20 slots in a single frame. Fig. 2.11 illustrates the slot divisions.

Code division access is implemented in 3G communications. More about this is discussed in the subsequent sections.

2.6.4 Core Network

Two optimizations for Cellular Internet of Things (CIoT) in the Evolved Packet System (EPS) were defined in order to send data to an application; the User Plane CIoT EPS optimization and the Control Plane CIoT EPS Optimization as shown in Fig. 2.6. Both optimizations may be used by NB-IoT or any other devices.

User Plane CIoT EPS optimisation

Data is transferred to the application server in the same way as the conventional traffic, that is, over radio bearers via the S-GW and the P-GW. This therefore creates some overhead on building up the connection, however it facilitates a sequence of data packet data to be sent. Both IP and non-IP data delivery is supported by this path.

Control Plane CIoT EPS optimisation

This solution is most appropriate for transmission of infrequent and small data packets.

UL data are transferred from the eNB (CIoT RAN) to the (Mobility Management Entity) MME. Then they are either transferred to the Serving Gateway (S-GW), to the Packet Data Network Gateway (P-GW), or to the Service Capability Exposure Function (SCEF). Finally, data is forwarded to the application server (CIoT Services).

DL data transmitted over the same paths in the reverse direction. In this solution, there is no data radio bearer set up, data packets are sent on the signalling radio bearer instead.

The SCEF is a new node designed especially for machine type data. It is used for delivery of non-IP data over control plane. It also provided an abstract interfaces for the network services which include authentication and authorization, discovery and access network capabilities.

2.6.5 Access Network

There is no difference to LTE (Fig. 3.1) on the overall architecture. The eNBs are connected, using S1 interface, to the MME and S-GW. Even though there is no handover defined, there is an X2 interface between eNBs, which enables fast resume after the eNB goes to the idle state.

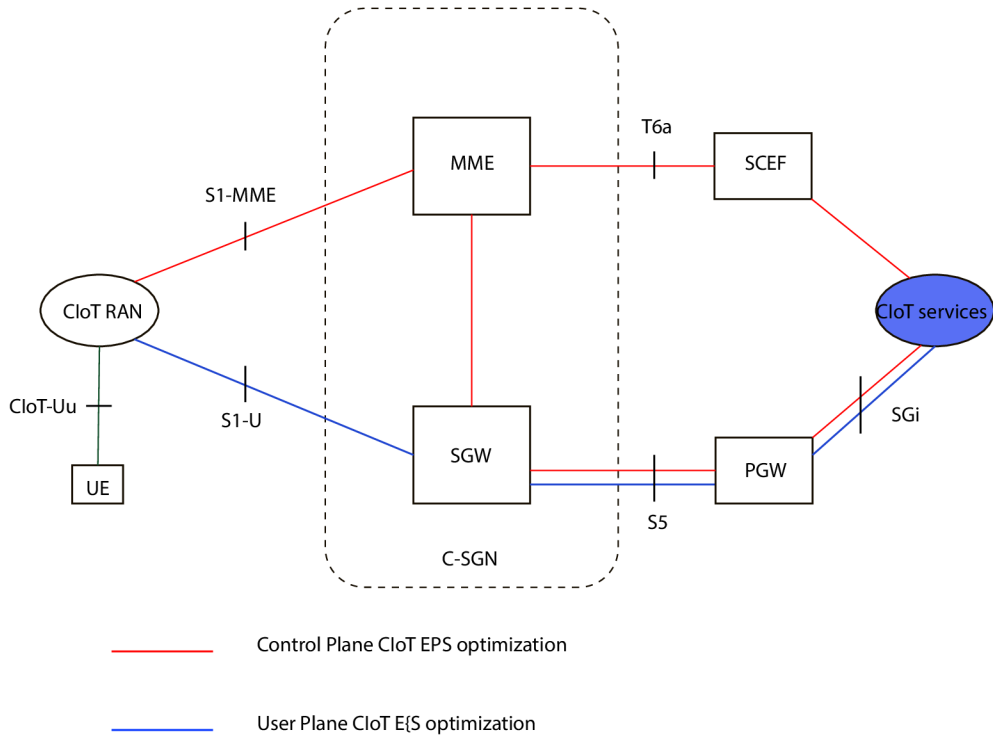

Fig. 2.6: Network for the NB-IoT data transmission and reception.

2.6.6 Spectrum, Frequency Bands and Operation Modes

The NB-IoT was meant to develop a new air interface specifically for low-power massive IoT, targeting mainly the reuse of the re-farmed Global System for Mobile Communications (GSM) spectrum [15], therefore, it is using the licensed part of the spectrum. For both uplink and downlink, NB-IoT operates on 180 kHz bandwidth which equals the legacy LTE resource block bandwidth. The re-farmed GSM spectrum (200 kHz per carrier), or the guard-band of an LTE carrier can be the resource blocks [15], Fig. 2.8.

The NB-IoT, unlike LoRaWAN and Sigfox can be deployed in-band and use the resource blocks within LTE carrier as well as those in guard band. In addition, it can be used as stand alone to enable deployments in dedicated spectrum. Fig. 2.8 shows the operation modes of NB-IoT.

- *Stand alone operation mode:* A possible scenario is the utilization of currently used GSM frequencies. With their bandwidth of 200 kHz there is still a guard interval of 10 kHz remaining on both sides of the spectrum.
- *Guard band operation mode:* utilizing the unused resource blocks within an

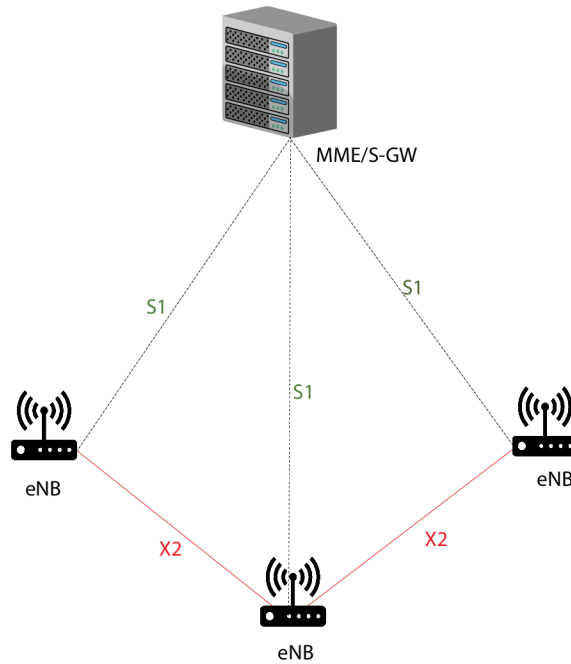

Fig. 2.7: Network architecture towards the air-interface.

LTE carrier's guard-band. This is currently, as of 2018, being used by Vodafone Czech Republic.

- *In-band operation mode*: utilizing resource blocks within an LTE carrier.

The LTE downlink transmission structure, orthogonal frequency-division multiple access (OFDMA) with 16 kHz sub-carrier spacing, is retained by the NB-IoT downlink (DL), whereas the uplink (UL) is Single-carrier frequency-division multiple access (SC-FDMA) with a sub carrier spacing at 3.75 kHz (to avoid interference from legacy LTE traffic, the in-band has a 15 kHz spacing), which, at the same time, is the minimum transmission bandwidth (i.e., single-subcarrier/tone transmission) for a device [15]. On top of the 140 dB LTE footprint (achieved by an increased number of temporal repetitions), the maximum coupling loss is extended to 20 dB and a power-efficient single subcarrier transmission with a $\pi/2$ -BPSK ($\pi/2$ Binary Phase Shift Keying) modulation [15]. This allows the end-devices to connect to the base stations at a distance ranging from a few to tens of kilometres depending on their deployment environment (rural, urban, etc.). Fig. 2.6 shows receiver sensitivities of LPWAN technologies.

Technology	Proprietary		3GPP	
	SIGFOX	LoRaWAN	LTE-M	NB-IoT
Default Tx Power, P	15 dBm	20 dBm	23 dBm	23 dBm
Maximum coupling loss, α	162 dBm	157 dBm	155 dBm	160 dBm
Receiver sensitivity, ρ	-147 dBm	-137dBm	-132 dBm	-137 dBm
Maximum bandwidth, w_0 ,	100 & 600 Hz	125 kHz	180 kHz	3.75 kHz

Tab. 2.6: Receiver sensitivity and minimum transmission bandwidth used by LPWAN technologies.

One major advantage of deployment in licensed region of the spectrum, which is regulated, is that there is a guarantee QoS and Quality of Experience (QoE). For unlicensed proposition it is harder as there are a number of other networks working in this unlicensed frequencies.

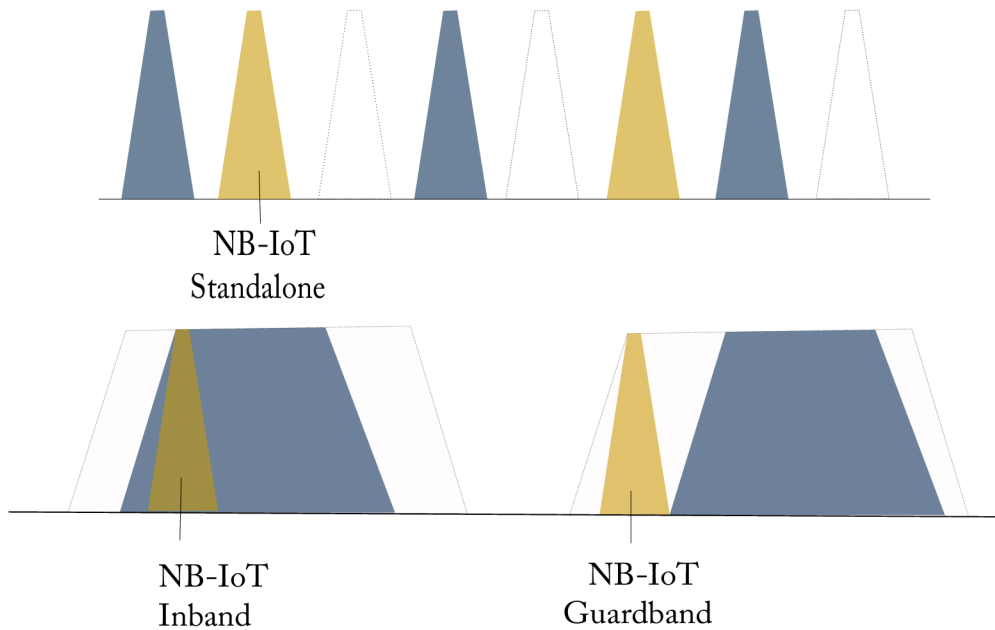

Fig. 2.8: NB-IoT operation modes.

In the case with the frequency bands, the same frequency numbers that are used in LTE are also used, with a subset defined for NB-IoT. Tab. 2.7 shows the bands in Release 13. It is also worth mentioning that most frequencies are in the lower

range of existing LTE bands. This reflects that for machine type communications there are a lot of devices expected in difficult radio conditions.

Band Number	Uplink Frequency Range / MHz	Download Frequency range / MHz
1	1920 - 1980	2110 - 2170
2	1850 - 1910	1930 - 1990
3	1710 - 1785	1805 - 1880
5	824 - 849	869 - 894
8	880 - 915	925 - 960
12	699 - 716	729 - 746
13	777 - 787	746 - 756
17	704 - 716	734 - 746
18	815 - 830	860 - 875
19	830 - 845	875 - 890
20	832 - 862	791 - 821
26	814 - 849	859 - 894
28	703 - 748	758 - 803
66	1710 - 1780	2110 - 2200

Tab. 2.7: NB-IoT Frequency Bands in Release 13.

2.6.7 Downlink

The following physical channels and physical signals are defined for the downlink;

physical channels

- NPBCH, the narrowband physical broadcast channel,
- NPDCCH, the narrowband physical downlink control channel,
- NPDSCH, the narrowband physical downlink shared channel,

physical signals

- NPSS and NSSS, Primary and Secondary Synchronization Signals,
- NRS, Narrowband Reference Signal.

Compared to LTE, these are less channels, the physical multicast channel PMCH is not included for example, because there is no MBMS service for NB-IoT.

Fig. 2.9 illustrates the connection between the transport channels and the physical channels.

Master Information Block (MIB) information is always transmitted over the NPBCH while the remaining signalling information are data over the NPDSCH. The NPDCCH controls the data transfer between the UE and the eNB.

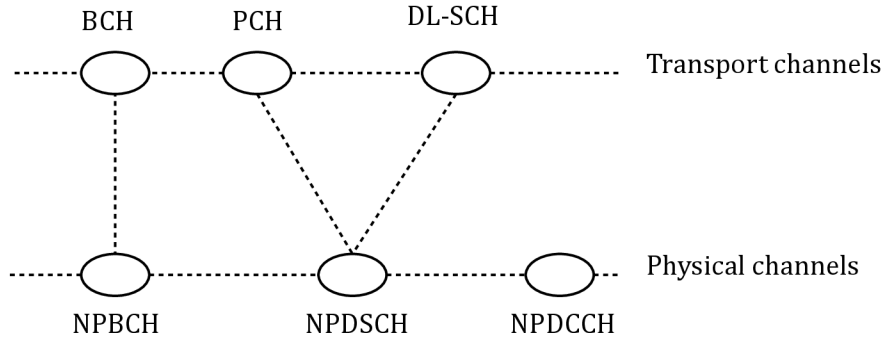

Fig. 2.9: Mapping of the transport channels to the physical channels.

The physical downlink channels are always QPSK modulated. Operation with either one or two antennae ports, AP0 and AP1 is supported by NB-IoT. *Space Frequency Block Coding*, (SFBC) is applied for the latter. Once selected, the same transmission scheme applies to NPBCH, NPDCCH, and NPDSCH.

Each cell has an assigned physical ID (PCID) like in LTE, *the Narrowband Physical cell ID* (NCellID). The values of the NCellID are assigned by the secondary synchronization signal (NSSS) fig

Frame and Slot Structure

OFDM is applied in the DL using a 15 kHz subcarrier spacing with normal cyclic prefix (CP). Each of the OFDM symbols consists of 12 subcarrier occupying this way the bandwidth of 180 kHz. So that the slot has the resource grid as shown in Fig. 2.10 [27], it is made of a bundle of seven OFDMA symbols.

The resource grid shown is the same as that of LTE in normal CP length for one resource block, which is important for the in-band operation mode

Narrowband Reference Signal

The narrowband reference signal (NRS) maybe used for broadcast or dedicated DL transmission whether the data is actually transmitted or not since it is transmitted in all SFs.

NRS is either transmitted on one antennae or two, this depends on the transmission scheme. Its values are generated like the CRS in LTE, with the NCellID taken for PCI. Fig. 2.12 shows the mapping sequence. It is additionally cyclically shifted by NCellID mod 6 in the frequency range. The same resource element is set to zero when NRSs are transmitted on two APs then on every resource element used for NRS on AP0.

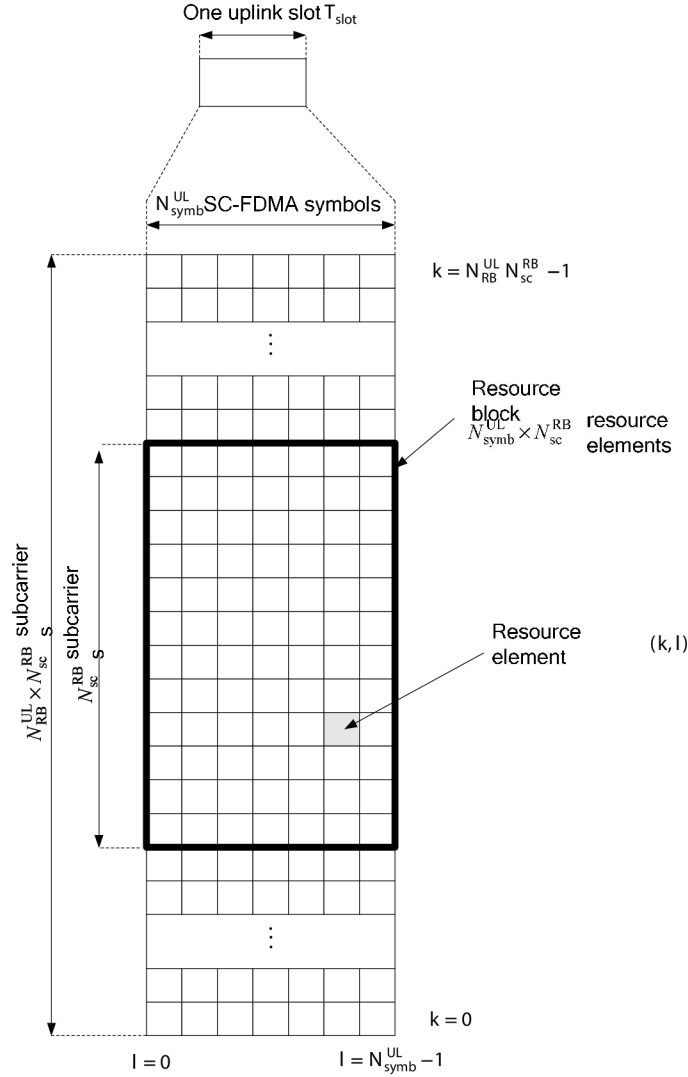

Fig. 2.10: Resource grid for one slot. There are 12 subcarriers for the 180 kHz bandwidth[27].

The frame has 1024 cyclically repeated radio frames with each having a duration of 10 ms. A radio frame is partitioned into 10 SFs with each composed of two slots Fig. 2.11 [26].

The concept of *hyper frames* is also defined in addition to the system frames, which counts the number of frame periods by its increment each time the system frames number wraps. Being a 10 bit counter, the hyper frame period spans 1024 system frame periods which corresponds to a time interval close to 30 hrs.

When it operates in-band, the LTE CRS are also transmitted in the NB-IoT bands for SFs which are not used for MBSFN. There is no overlap in LTE CRS and the NRS with the structure of NRS, for matching and resource element mapping

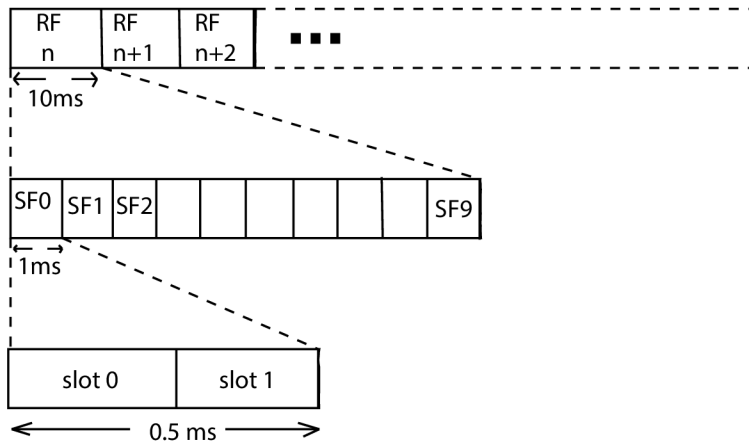

Fig. 2.11: Frame structure for NB-IoT for DL and UL with 15 kHz subcarrier spacing.

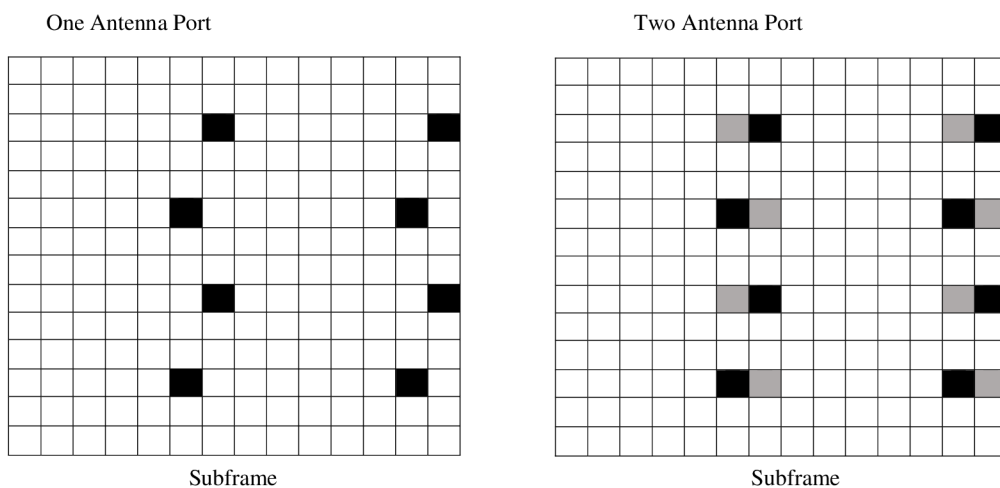

Fig. 2.12: Basic mapping of reference signals to the resource elements. NSR transmitted by port 0 are black and port 1 are grey.

however, the CRS have to be taken into account. All downlink transmissions have to skip these resource elements and must not use them.

Narrowband Physical Broadcast Channel

The NPBCH carries the Narrowband Master Information Block (MIB-NB) which is transmitted over a time period of 640 ms i.e. 64 radio frames. and contains 32 bits.

It contains the following information:

- 2 bits indicating the two LSBs of the hyper frame number,
- 4 bits indicating the most significant bits (MSBs) of the System Frame Number, (SFN), the remaining least significant bits (LSBs) are implicitly derived from the MIB-NB start,
- 5 bits indicating the system information value tag,
- 4 bits for the SIB1-NB scheduling and size,
- 2 bits indicating the two LSBs of the hyper frame number,
- 7 bits indicating the operation mode with the mode specific values,
- 1 bit indicating whether access class barring is applied,
- 11 spare bits for future extensions.

2.6.8 Uplink

For the uplink (UL), the following physical channels are defined:

- NPUSCH, the narrowband physical uplink shared channel,
- NPRACH, the narrowband physical random access channel,
- DMRS, Demodulation Reference Signal.

In the UL, all data and control information except the RACH is sent over NPUSCH. Fig. 2.13 shows the connection between the transport and physical channel in the uplink.

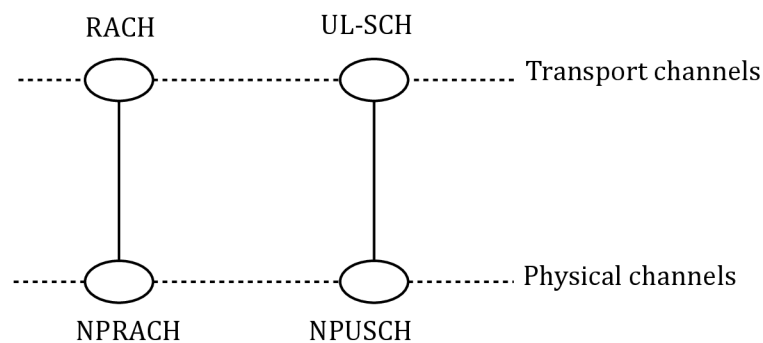

Fig. 2.13: Physical and transport channels mapping.

Physical Uplink Shared Channel NPUSCH

The following two formats for uplink shared channel are defined in NB-IoT:

- NPUSH format 1, for uplink transport data with a maximum TB size of 1000 bits,
- NPUSH format 2, for Uplink Control information UCI transmission.

2.6.9 Performance of NB-IoT

NB-IoT has a narrow bandwidth for low data rate communication. In in-band operation mode, one or more LTE Physical Resource blocks (PRBs) are reserved for NB-IoT. The total base-stations (eNB in 3GPP terminology) power is shared between NB-IoT and LTE with the possibility for NB-IoT to use Power Spectral Density (PSD) boosting [28]. Due to its small bandwidth, the PSD of NB-IoT carrier can be boosted by 6 dB compared to legacy LTE. This improves coverage.

With respect to the performance objectives, the following are techniques that are used to satisfy each of the performance objectives [28]:

- **Ultra-low-complexity of device:**
 - half duplex mode only,
 - narrowband transmission has only one receive antennae (receiver chain) at the device,
 - instead of Turbo, it uses Convolutional coding,
 - the maximum transport block size is limited. This results in a reduced peak data rates,
 - it supports only one Hybrid Automatic Repeat reQuest (HARQ) process,
 - supports only BPSK/QPSK modulation,
 - it has relaxed processing time.
- **Improve indoor coverage by 20 dB:**
 - repetitions,
 - PSD boosting,
 - using single-tone transmission with phase rotation modulation to reduce peak-to-average power ratio in the uplink.

Cellular networks have the enormous advantage of covering large areas to reach multiple M2M devices without the need for repeaters or numerous base stations. This is a huge advantage for NB-IoT.

2.6.10 Reliability

NB-IoT was designed with HARQ which led to relaxed timing requirements. The UE expects any time later than four frames after transmission has ended. This means there is no explicit acknowledgements or negative acknowledgements (ACK & NACK) because there is no separate feedback channel ² in the downlink as in legacy LTE. The UE assumes, after waiting for the next uplink grant, the previous data were not received when the new data indicator (NDI) in the downlink control

²Physical HARQ indicator channel.

information (DCI) is not set [29]. Because NB-IoT (and LTE-M) are SIM-based technologies, they deliver carrier-grade, best-in-class security measures[30].

2.6.11 Power Control

Essentially, NB-IoT has been designed for low cost, long battery life, high coverage, and deployment of a large number of devices. In order to maximize the battery life for enhanced Machine Type Communication (eMTC), 3GPP adopts two features[31]:

- Power Saving Mode (PSM),
- extended Discontinuous Reception (eDRx).

These two features enable the end device to enter a deep sleep mode for a long time (hours or even days)[31] without losing their registration in the network. To save energy, the end devices stop monitoring downlink control channel for prolonged periods of time.

In the UL, the transmitted power depends on a combination of cell specific parameters the selected Resource Unit (RU) and UE measured parameters.

DL transmission power refers to the NRS transmission power. Its value is indicated to the UE in order to estimate the path loss. It is constant for all resource elements carrying the NRS and all SFs.

For the NPBCH, NPDCCH and NPDSCH the transmit power depends on the transmission scheme. If only one antenna port is applied, the power is the same as for the NRS, otherwise it is reduced by 3 dB.

A special case occurs if the in-band operation mode is used and the same PCI value is set to true. Then the eNB may additionally signal the ratio of the NRS power to the CRS power, enabling the UE to use the CRS for channel estimation as well.

Fig. 2.14 shows typical operations involved in device-originated (power up or in response to higher layer data transfer request) and network-originated (paging) calls.

2.6.12 Future perspectives

Given its flexibility in massive machine type communication (MTC), deployment within cellular systems and cost-efficiency, NB-IoT presents as an attractive new technology.

The NB-IoT design has many similarities to LTE, and can, in many cases, be deployed as a software upgrade to an operator's existing LTE network [33]. It therefore broadens the applicability of cellular technologies as the connectivity of choice from high-performance and high-end devices towards the IoT devices which are simpler and of lower-cost.

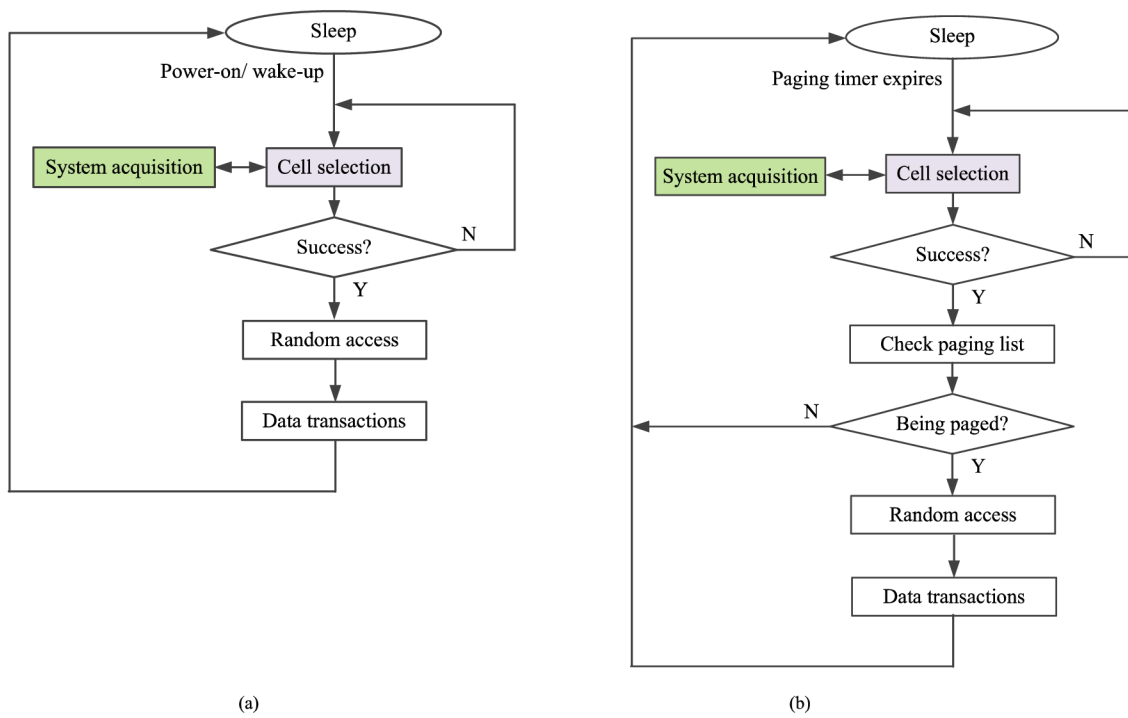

Fig. 2.14: (a) Device-originated calls. (b) Network-originated calls [32]

3 IMPLEMENTATION OF NB-IoT SCENARIO

3.1 General description

A network simulator is a program which models the behaviour of a network without an actual network being present [34]. In the area of computer networks, network simulation is one of the most predominant evolution methodologies [35]. This is because networking community largely depends on simulation to emulate the performance and behaviour of networking protocols for networks. During the past years, different network simulation programs have been developed in the field of communication.

Among the most famous of network simulators are Network Simulator 2 (NS-2), Network Simulator 3 (NS-3), NetSim, QualNet, OPNET Riverbed et cetera. Below is an overview of some network simulators and emulators:

- **Network Simulator 2:** NS-2 has a dual language architecture: C++ and OTcl with C++ being used for core elements and models which compile once and run many times using scripting language Tcl/OTcl for simulation [34]. The Tcl/OTcl scripts are used to simulate and control the wired and wireless networks while the C++ code is used to model network behaviour.
- **Network Simulator 3:** NS-3 is neither the extension of ns-2 nor its replacement. It is a free and open source like ns-2 and is written in C++ and supports optional python scripting language for simulation [34].
- **NetSim:** NetSim is a web-based game intended to teach high school aged children the basics of network routing and how common attacks are performed against it by hackers [36].
- **Graphical Network Simulator 3:** Graphical Network Simulator 3 (GNS3) is a network software that was first released in 2008 which allows the combination of virtual and real devices used to simulate complex networks. It is mostly used to emulate real network environments in real or virtual machines for practical laboratory or as a test of configurations before deployment in a campus or enterprise network [37].

NS-3 is a free source and designed primarily for educational and research purpose. For its support and capability for all the requirements in configuring, running, visualizing and monitoring network processes, it is chosen as the simulator for the scenario in this thesis.

3.2 Network Simulator 3

3.2.1 Architecture

As already highlighted above, NS-3 is one of the most popular network simulation tools. Its project was initiated in 2006 as an open source, discrete event network simulator and was developed primarily for research and education purposes. The ns-3 project is designing a follow-on successor to the ns-2 simulator. It's a user-space program that runs on Unix- and Linux-based systems and on Windows [38].

Use cases

- **Model Extensibility.** Researchers users can extend the simulator by writing new simulation scripts, modify existing models or write new models.
- **Simulation code reuse**
- **Run-time configuration** A flexible technique is provided by *ns-3* to allow users to redefine default values and class values without having to recompile the simulator.
- **Tracing**
- **Scaling.**
- **Scripting** The primary ns-3 user interface at present is a C++ “main” program, and it is expected that C++ will continue to be a preferred language for many users.
- **Software integration.**
- **Network emulation.** The ns-3 design is intended to facilitate interaction between simulation and experiments, with a packet design oriented towards serialization and deserialization, and encapsulation techniques that will allow real application and kernel code to run in the simulator, thereby improving traceability to real-world implementations.

3.2.2 LTE-EPC Network Simulator

LTE-EPC Network Simulator (LENA) is an open source product-oriented LTE-EPC network simulator that allows the design and test Self Organized Networks (SON) algorithms by LTE small/macro cell vendors. The target applications of LENA include: design and performance evolution of UL and DL Schedulers, Inter-cell interference Coordination solutions, Radio Resource Management Algorithms, Mobility management and load balancing, Multi-RAT network solutions, Cognitive LTE based systems and Heterogeneous Networks (HetNets) solutions [39].

3.2.3 LENA application in NS-3 environment

The simulation of LTE network uses the LENA environment in NS-3. A general view of the LTE model is illustrated in Fig. 3.1 [40] [39]. It is formed from two major parts - the LTE network and the EPC (Evolved Packet Core).

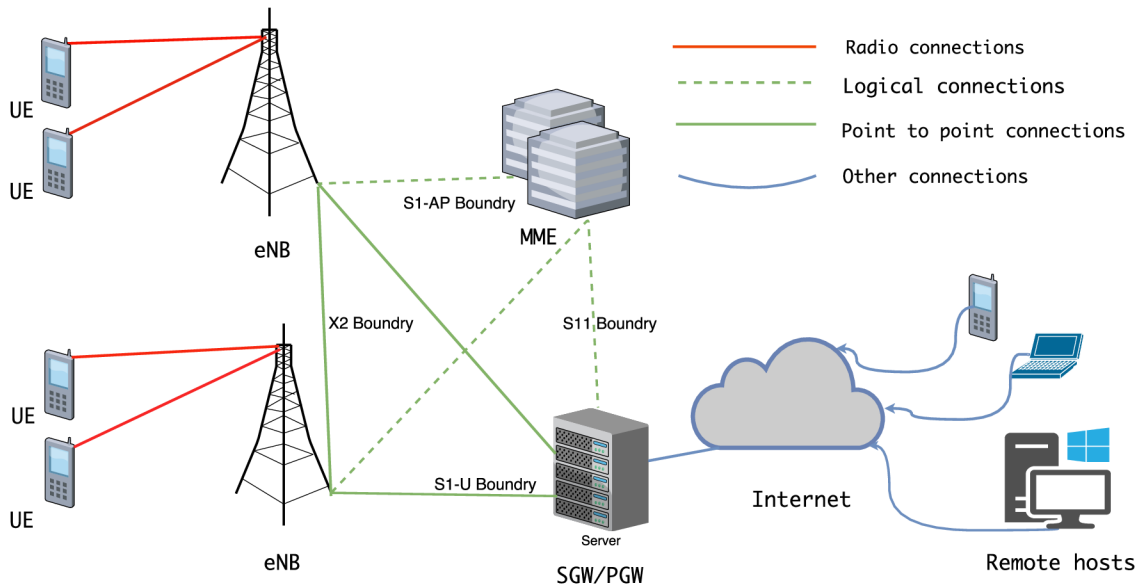

Fig. 3.1: LTE topology created in LENA.

NB-IoT and LTE share the same network architecture. In addition to the two basic entities earlier mentioned, UEs and eNodeBs, the model further contains environments for radio connectivity creation for example between a UE and an eNB and network protocols which includes the following:

- RRC (Radio Resource Control) - this protocol exists in UE and eNB. It is part of LTE air interface plane. The following among others are the main services and functions of the RRC sub-layer [41]:
 - Broadcasting System Information related to the NAS (non-access stratum).
 - NAS direct message transfer to and from NAS from/to UE
 - Paging.
 - Reporting of UE measurements and control of the reporting.
 - Broadcast and System Information which are related to the access stratum.
 - Establishment, maintenance and release of an RRC connection between the UE and E-UTRAN.
 - Key management and other security functions.
 - Establishment, maintenance, configuration and release of point to point

Radio Bearers and E-UTRANS (Enhanced Universal Terrestrial Radio Access Network).

- QoS management functions.
- Mobility functions.
- PDCP (Packet Data Convergence Protocol) - this protocol layer exists in UE and eNodeB. Like RRC, it is part of LTE air interface control and user planes. The main service include among others: header compression and decompression, transfer of user data, time-based SDU discard in uplink, ciphering, retransmission of CPD SDUs at handover for RLC AM, detection of duplicate of lower layer SDUs at PDCP re-establishment procedure for RLC AM. The main functions and services of PDCP for the control plane include: ciphering and integrity protection and Transfer of control plane data [42].
- RLC (Radio Link Control) - it exists in UE and eNB. The the RRC and PDCP, it is part of the LTE air interface planes. It's key functions include: RLC re-establishment, RLC SDU discard, transfer of upper PDUs, error correction, re-segmentation of RLC SDU among others [43].
- MAC (Mac Layer) - is the second layer of the network model.
- PHY (Physical Layer) - The physical layer is the first layer of the network module. It exists inside every UE and eNB.

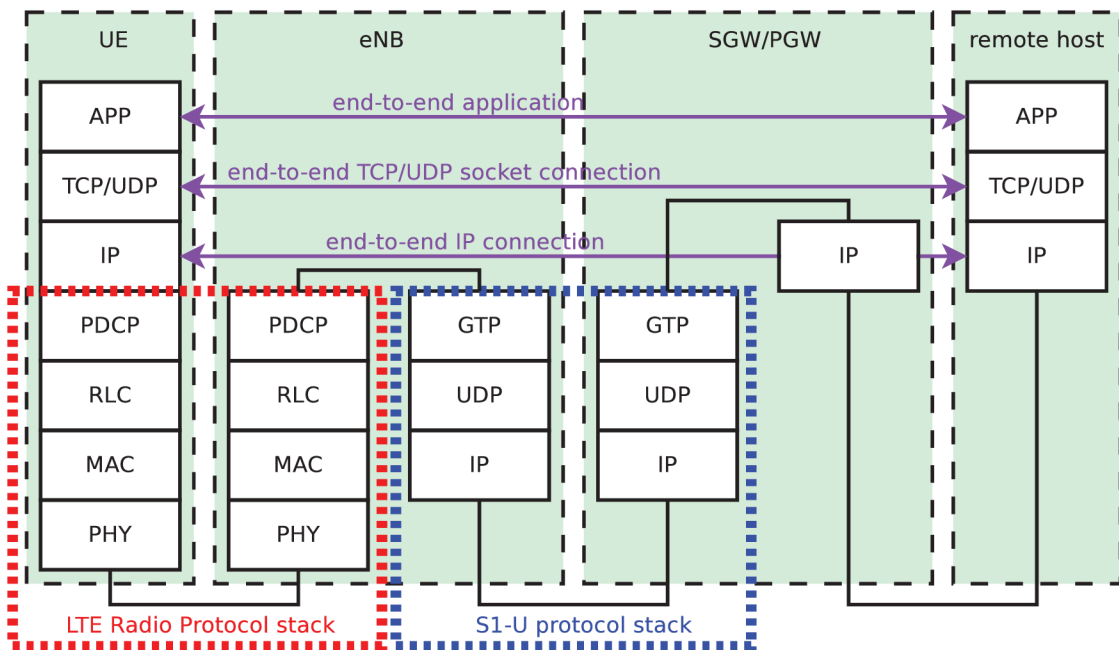

Fig. 3.2: LTE-EPC data plane protocol stack.

The EPC model contains so-called system core. It is the latest evolution of the 3GPP core network architecture. It was first introduced by 3GPP in Release 8 of

the standard. The UE are connected to EPC by E-UTRAN (LTE access network).

The eNB is the base station for LTE radio. EPC is composed of the following basic network elements: the serving gateway (S-GW), the Packet Data Network Gateway (P-GW), the MME (Mobility Management Entity) and the HSS (Home Subscriber Server). The EPC connects to the Internet (or any external networks, which can include IP Multimedia Core Networks, IMS)[44]:

- HSS: In the provided simplified Fig. 3.1, this network element has not been included. Basically it is a database that contains user-related and subscriber-related information. It can be implemented in the server.
- S-GW: The S-GW and P-GW deal with the user plane. They transport IP traffic between UE and the remote devices. The functions of S-GW include: establishing bearers based on the directives of the MME, user data function handling such as routing and forwarding of data, non-3GPP access among others [45]. In case of handover between eNB nodes, the S-GW is the anchor point (i.e for intra-LTE mobility) and between LTE and 3GPP access. It is connected to the P-GW logically.
- P-GW: This is the point of interconnection between the EPC and the external network (Internet) which are called Packet Data Networks (PDN). This gateway routes data to and from the PDNs. Various other functions such as IP address/IP prefix allocation or charging and policy control are performed by the PDN GW [44].
- MME: Mobility Movement Entity (MME) is the termination of NAS. It deals with the control plane. Signalling related to security and mobility for E-UTRAN is handled by MME. It has a responsibility of paging and tracking of UE in idle mode[45].

Fig. 3.2 [46] shows the LTE-EPC data protocol stack.

3.2.4 Used modules

Propagation modules

The aim of the propagation model simulation is to implement a time-variant channel, this is in order to correctly represent the main features of a dense urban scenario. The Recommendation ITU-R P.1411-8 describes propagation model for short-range outdoor communication in the frequency range 300 MHz to 100 GHz. The communication

The Propagation Module implements complex propagation and error models on the transmission of wireless signals. Several channel models such as Ferriis, Okamura-Hata and an attenuation model due to the presence of buildings in the channel are included in NS-3. The user can set different propagation conditions and Tx/Rx

parameters such as antenna gains and channel model, how transmission power associated to each signal is attenuated and delayed in the simulation.

The NS-3 propagation module defines two generic interfaces; `PropagationLossModel` and `PropagationDelayModel` for the modeling of respective propagation loss and propagation delay.

PropagationLossModel

The propagation loss models calculate the Rx signal power considering the Tx signal power and the mutual Rx and Tx antennas positions. A list can be made by “chaining” one propagation model to another one. All the chained models are taken into account by the final Rx power. In this way, for example, one can use a slow fading and a fast fading model, or model separately different fading effects. The following is a list of some of the implemented propagation delay models: [47].

- `TwoRayGroundPropagationLossModel`,
- `RangePropagationLossModel`,
- `RandomPropagationLossModel`,
- `FriisPropagationLossModel`,
- `LogDistancePropagationLossModel`,
- `FixedRssLossModel`,
- `MatrixPropagationLossModel`.

In the following subsections, a brief explanation is given to a few of the propagation delay models above:

`TwoRayGroundPropagationLossModel`

This model implements a Two-Ray Ground propagation loss model ported from NS2. The Two-ray ground reflection model uses the formula

$$P_r = \frac{P_t * G_t * G_r * (H_t^2 * H_r^2)}{d^4 * L}, \quad (3.1)$$

L is assumed as $L = 1$ in the original equation in Rappaport’s book. H_t and H_r are set at the respective nodes z coordinate plus a model parameter set via `SetHeightAboveZ`.

RangePropagationLossModel This model implements a log distance propagation model. The reception power is calculated with a so-called log-distance propagation model:

$$L = L_0 + 10n \log \frac{d}{d_0}, \quad (3.2)$$

where:

n : the path loss distance exponent,

d_0 : reference distance (m),

L_0 : path loss reference distance (dB),

d : distance (m),

L : path loss (dB).

FriisPropagationLossModel

The Friis propagation model is implemented by this model. Eqn. 3.3 shows the original description of the equation.

$$\frac{P_r}{P_t} = \frac{A_r A_t}{d^2 \lambda^2}, \quad (3.3)$$

Eqn. 3.4 in case of an isotropic antenna with no heat loss.

$$A_{isotr.} = \frac{\lambda^2}{4\pi}, \quad (3.4)$$

Eqn. 3.5 is the final equation.

$$\frac{P_r}{P_t} = \frac{\lambda^2}{(4\pi d)^2}, \quad (3.5)$$

Eqn. 3.6 is the modern extensions to the original equation.

$$P_r = \frac{P_t G_t G_r \lambda^2}{(4\pi d)^2}, \quad (3.6)$$

With:

P_t : transmission power (W),

P_r : reception power (W),

G_t : transmission gain (-),

G_r : reception gain (-),

λ : wavelength (m),

d : distance (m),

L : system loss (-).

During implementation, λ is calculated as $\frac{C}{f}$ where $C = 2.9979245 \text{ m/s}$, the speed of light in vacuum, and f is the frequency in hertz which is configurable by the user via the frequency attribute [47].

PropagationDelayModel

The following are propagation delay models:

- RandomPropagationDelayModel,
- ConstantSpeedPropagationDelayModel.

RandomPropagationDelayModel

The propagation delay is completely random and changes each time the model is called. As a consequence of all packets (even those between two fixed nodes) experiencing random delays, the packet order is not preserved [47].

ConstantSpeedPropagationDelayModel

The signal travels with constant speed in this model. The receiver and the transmitter positions are used to calculate the delay. The Euclidean distance between the transmitter and the receiver are used. This model assumes that the earth is flat [47]

Spectrum modules

In the spectrum module, each transmitted packet is described as a signal with its relative power spectral density representation allowing mutual interference between signals to be taken into account as well as out-of-band signals components.

The goal of both Propagation and Spectrum Modules is to provide a measure of the received packet signal power along with both the thermal and interference noise. The receiver then converts the power into a Bit Error Rate (BER). By using a simple statistical approach, the receiver can evaluate the if a certain packet has been received correctly or not.

Mobility Module

In NS-3, the mobility supports:

- a set of mobility models which are used to track and maintain the current cartesian position and speed of an object.
- a “course change notifier” trace source which can be used to register listeners to the course changes of a mobility model
- a number of helper classes which are used to place nodes and setup mobility models (including parsers for some mobility definition formats)

The mobility module allows for the setting of the position and the mobility of the nodes in the simulation. This is done by setting coordinates of the position and the direction and speed of motion the node in question assumes in this movement [48]. The source code for mobility lives in the directory `src/mobility`.

The design of the mobility includes mobility models, position allocators and helper functions. The `MobilityModel` objects track the evolution of position with respect to a coordinate system. It is typically aggregated to an `src/flow-monitor ns3::Node` object and queried by `src/flow-monitor GetObject<MobilityModel> ()`. The base class `ns3::MobilityModel` is subclassed for different motion behaviours.

Typically, a `PositionAllocator` is used to set the initial position of the object. The position of the notional canvas is laid out by this types of objects. After the start of the simulation, the `PositionAllocator` may be used to pick future mobilities “waypoints” for such models or may no longer be used.

The mobility system is mostly interacted by users by using the mobility helper classes. Both mobility model and a position allocator are combined in `MobilityHelper` and can be used by a node container to install mobility capabilities on a set of nodes.

At present, NS-3 uses only the Cartesian coordinate system. The base class for a coordinate is the `ns3::Vector`.

MobilityModel

The mobility model describes the following base class

- `GetPosition()`,
- `GetDistanceFrom`,
- Position and Velocity attribute,
- `CourseChangeNotification`,

Since NB-IoT technology deals with monitoring fixed objects, the Position and Velocity attribute and `CourseChangeNotification` are not used in this simulation.

MobilityModel Sublasses

- `SteadyStateRandomWaypoint`,
- `ConstantPosition`,
- `RandomDirection2D`,
- `Hierarchical`,
- `ConstantAcceleration`,
- `Waypoint`,
- `GaussMarkov`,
- `ConstantVelocity`,
- `RandomWaypoint`,
- `RandomWalk2D`,
- `RandomWaypoint`,

Helper

The installation of mobility to a Node container when using containers at the helping API level is supported by a special mobility helper whose main aim is to install mobility to such nodes.

It's usage is shown in below in Appendix A.1

This code tells the mobility helper to use a two-dimensional grid to initially place the nodes. The first argument is an ns-3 TypeId specifying the type of mobility model; the remaining attribute/value pairs configure this position allocator.

PositionAllocator

They are usually used at the beginning, to lay out the nodes initial position with a few exceptions of some mobility models such as RandomWaypoint which will use a position allocator to pick new waypoints.

- ListPositionAllocator
- GridPositionAllocator
- RandomRectanglePositionAllocator
- RandomBoxPositionAllocator
- RandomDiscPositionAllocator
- UniformDiscPositionAllocator

MobilityModel

Describes base class.

- GetPosition ()
- Position and Velocity attributes
- GetDistanceFrom ()
- CourseChangeNotification

MobilityModel Subclasses

This module allows the position and the mobility of the nodes placed in the simulation to be set using co-ordinates of the positions. Direction and speed of the movements the node assumes during the simulation can also be set. There is also a possibility to set many different kinds of mobility for the nodes:

- ConstantPosition
- ConstantVelocity
- ConstantAcceleration
- GaussMarkov
- Hierarchical
- RandomDirection2D
- RandomWalk2D
- RandomWaypoint
- SteadyStateRandomWaypoint
- Waypoint

Flow Monitor modules

The goal of this module is to provide a flexible system for measurement of the performance of a network protocol. The source code for the new module is in the directory `src/flow-monitor`. Probes that are installed in the network nodes are used by the module to track the packets exchanged by the nodes. In this way, it can measure a number of parameters. There are a number of flows defined according to the probe's characteristics and packets are also divided according to the flow they belong to. A flow for IP, for example, is defined as the packets with the same protocol, source (IP, port), destination (IP, port) tuple.

Each flow can be statistically collected and exported as an XML file. In addition, the probes can be accessed more directly to request specific statistics about each flow [49]. The design of the Flow Monitor module is in a modular way. It can be extended by sub classing `ns3::FlowProbe` and `ns3::FlowClassifier`.

Its typical use is shown in the example code below:

```
// Flow monitor
Ptr<FlowMonitor> flowMonitor;
FlowMonitorHelper flowHelper;
flowMonitor = flowHelper.InstallAll();

Simulator::Stop (Seconds(stop_time));
Simulator::Run ();

flowMonitor->SerializeToXmlFile ("NameOfFile.xml",
    true, true);
```

Helper

The API follows the pattern usage of normal helpers. The monitor in the nodes can be installed through the helper. The helper can also be used to set the monitor attributes and print statistics. It's important to note that the `ns3::FlowMonitor` must be initiated only once in the main..

3.3 Proposed changes in NS-3 towards NB-IoT implementation

In this section, the implementation choices done when simulating are described. The NS-3 simulator features are continuously renewing and enhancing but it does not provide yet and NB-IoT functionalities. That is why, since this technology is built upon the LTE functionalities, substantive changes will be implied to the LTE model in NS-3 to make it to work according to the characteristics of an NB-IoT system.

In this simulator, the Serving Gateway and the Packet-Data Gateway can not be used together since there has been no implementation of the S-GW in the code so the P-GW is assumed to take the role of both gateways.

The default antenna is the Isotropic Antenna. An attempt to implement a tri-sectoral antenna by modifying `CosineAntennaModel` was not successful. The idea was to put three antenna nodes in exactly the same position but different orientations: one at 0° , the second at 120° and the third at 240° . Beamwidth was set to a `DoubleValue` of 120 and frequency of 800 MHz. The gain was set to 20 dB. The LTE module in NS-3 uses allows the use of 6, 16, 25, 50, 75 or 100 PRB each of which corresponds to a different bandwidth in transmission. By default the 50 PRB is set which corresponds to a 10 MHz bandwidth. It is possible to use a different number of PRB by modifying the libraries `lte-enb-net-device.cc` and `lte-frr-algorithm.cc`, Appendix A.2

By adding a "case 12: " in the switch (bw) in the code, the use of 12 PRB is enabled. This can be set in the attributes as:

```
lteHelper->SetAntennaModelAttribute("UIBandwidth",  
    UIntegerValue(12));
```

The frequency of 800 MHz is set as:

```
lteHelper->SetPathlossModel("Frequency",  
    DoubleValue(800e6));
```

On implementing the tri-sectoral antenna as described above, the following anomalies were noticed:

- Only one sector of the antenna assumes the function of the whole antenna and the other two were not involved in packet transmission. Usually the first antenna of the three was active,
- Certain attributes were reported invalid, for example, the UIBandwidth:

```
msg="Invalid attribute set (UIBandwidth) on
ns3::CosineAntennaModel",
file=../src/core/model/object-factory.cc, line 75
```

```
Creating topology --> OK
Creating a P2P connection --> OK
Creating mobility --> OK
msg="Attribute name=PathLossModel does not exist for this object: tid=ns3::LteHe
lper", file=../src/core/model/object-base.cc, line=192
terminate called without an active exception
Command ['/home/student/ns-allinone-3.27/ns-3.27/build/scratch/NB-IoT'] terminat
ed with signal SIGIOT. Run it under a debugger to get more information (./waf --
run <program> --command-template="gdb --args %s <args>").
```

Fig. 3.3: Error from additional attributes.

The same thing with the UIEarIcfn and PathLossModel.

As a result it a simple antenna with fewer attributes was implemented, Appendix A.3

“”

4 SIMULATION AND RESULTS

4.1 Description of created communication scenario

The functional parts of the topology are implemented in the simulation tool NS-3. The basic configurations of the UE, eNodeB, P-GW and remoteHost are given with respect to the characteristics and methods required to perform their specific tasks. Fig. 4.1 shows the topology of the scenario created.

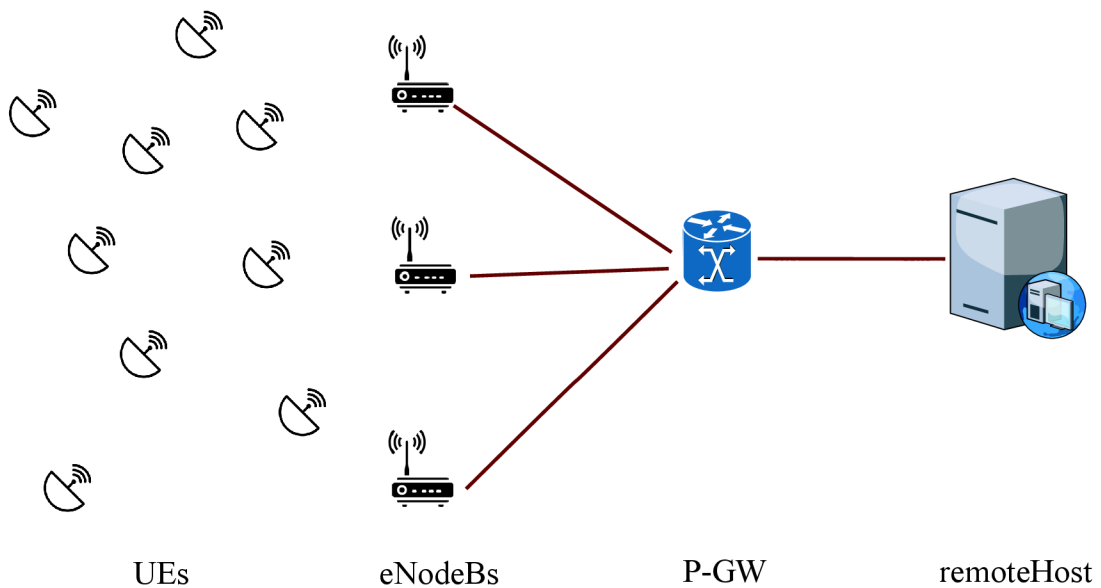

Fig. 4.1: Topology of the scenario for simulation.

The topology is made up of a number of fix positioned eNodeBs, a P-GW and remote host. These will stay in the same coordinates during the simulations. The network further contains 500 fixed nodes (UEs) which are placed at random positions from the base stations eNodeBs through out the simulation. This number of devices is chosen due to the nature of M2M data transmission. When a real life scenario is taken, a dense urban area for example, there is bound to be high density of smart machines. A single family apartment may have multiple devices and meters that are connected through IoT. NB-IoT is suitable for these fixed-position MTC. The locations of these end devices is generated by the RandomBoxPositionAllocator. The code used to allocate positions to the UEs is shown in Appendix A.4.

The base station that each UE connects to is chosen on the basis of the shortest distance between them:

```

for (int i = 0; i < numberOfUes; ++i){
lteHelper->AttachToClosestEnb(ueDev.Get(i), enbDev);
}

```

For the generation of traffic between the UEs and the remote host, two transport protocols are used: Transport Control Protocol, TCP, and User Datagram Protocol, UDP. OnOffApplication is used to generate the TCP traffic. For the UDP traffic, UdpClientHelper is used. The first half of the devices uses UDP and the second half uses TCP. Appendix A.5 shows the code used for UDP and Appendix A.6 for TCP.

The Sounding Reference Signal (SRS) is a reference signal transmitted by the UE in the uplink direction which is used by the eNodeB to estimate the uplink channel quality over a wider bandwidth. The eNodeB may use this information for uplink frequency scheduling. Too many UEs for current SRS periodicity 320, consider increasing the value of ns::LteEnbRrc::SrsPeriodicity, file=../src/lte/model/lte-enb-rrc.cc line 2775. The SRS periodicity was changed to 1024 to accommodate all the UEs.

On/off application has been installed on the LTE network in order to generate data traffic. The data is sent from the remote host to the UE. This data is a DL data on the side of the UE and an UL on the side of the remote host. The traffic from the UE to the remote host is an UL on the side of the UE and a DL on the side of the remote host.

4.2 Results and lessons learned

4.2.1 Flow of data in the simulation

The functions of the essential components of the NB-IoT simulation network, which are basically the same as discussed earlier in LTE, Section 3.2.3, are simplified in Fig. 4.2.

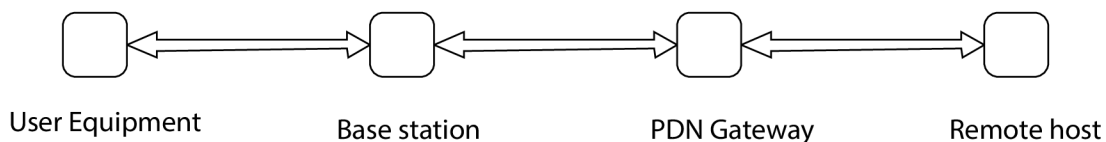

Fig. 4.2: Simplified NB-IoT network topology.

- **User Equipment:** The UE generates data which it sends to a remote host (UL) as well as receives data from a remote host (DL). The UE connects to the base station via radio resource (air interface).

- **Base Station:** The base station is responsible of connecting the UE and the PGW. It receives data from the UE and forwards it to the PGW and vice versa.
- **PDN Gateway:** The P-GW connects to the remote hosts. It is the gate of the local network to the global network, the Internet.
- **Remote Host:** The remote host is the furthest entity from the user with which the UE communicates. In this scenario, it is the remote host that initiates the communication.

Fig.4.3 shows the whole scenario of the 500 UEs connected to the 5 EnodeBs which connects to the P-GW and finally to the remote host. This is created by NetAnim from the xml file generated during the simulation.

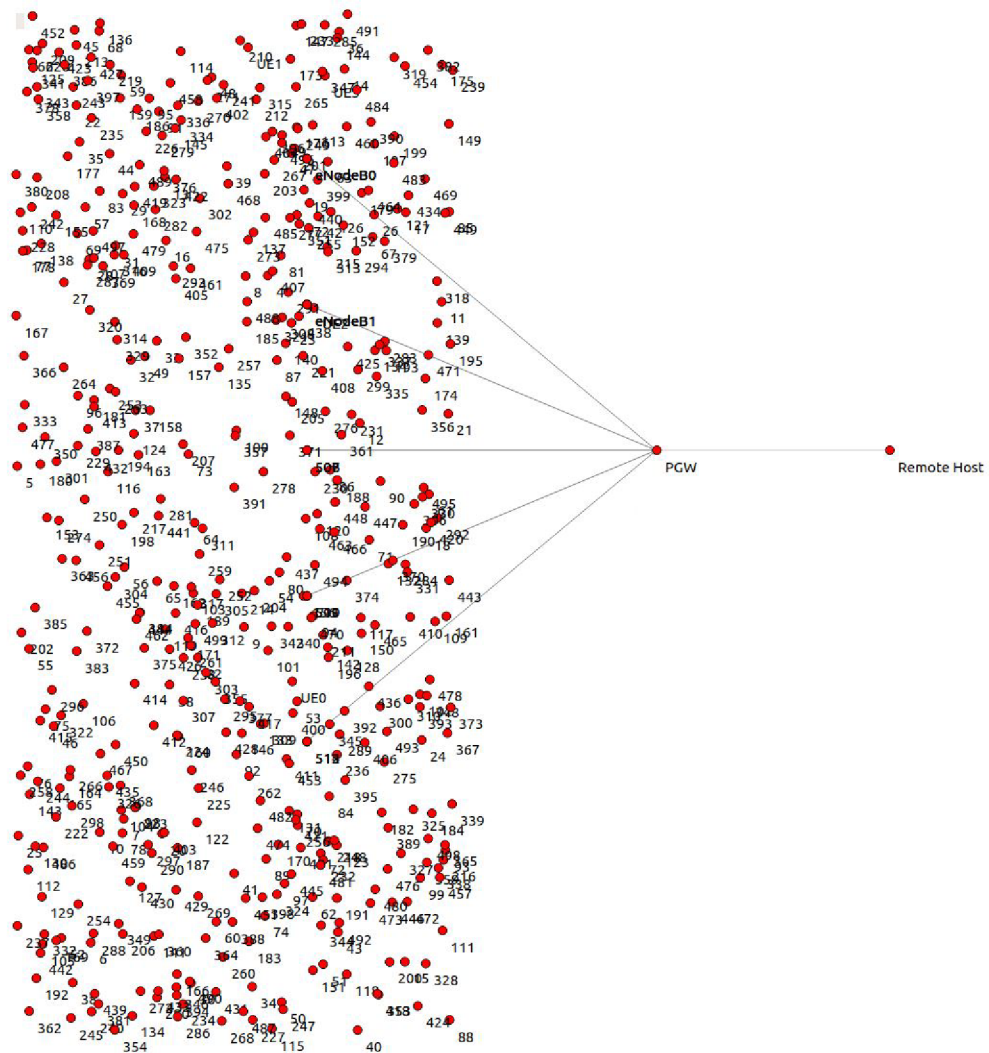

Fig. 4.3: Topology in NetAnim.

Some of the most important parameters and modules used in the simulation are summarized in Tab. 4.1. Appendix B contains screen prints of the output parameters of QoS: Tx, Rx, delays, jitters, throughputs and percentage of packets lost.

Coverage

The selection of the eNodeB by the UE does not guarantee that the eNodeB was reachable by the UE. Therefore there was not straight forward way to tell whether all the nodes were within network coverage of their respective eNodeBs.

Parameter	Value	Unit
Simulation time	24	seconds
Number of UEs	500	-
Number of ENBs	5	-
Throughput in core	1	GBps
Maximum gain	23	dBm
UEs (TCP)	250	UEs
UEs (UDP)	250	UEs
Frequency	800	MHz
Time Interval	30	seconds
Delay	1	ms
Maximum Transfer Unit	1 500	bits
Maximum Packet Size	1 024	bits

Used Models and Helpers

Model/Helper	Model/Helper Used
MobilityModel	ConstantPositionMobilityModel
Position Allocator UEs EnodeBs P-GW Remote Host	ConstantPositionMobilityModel GridPositionAllocator ListPositionAllocator ListPositionAllocaror
Antenna Model	CosineAntennaModel
Transport Protocols UDP TCP	UdpClientHelper OnOffApplication
Monitor	FlowMonitorHelper

Tab. 4.1: LTE UE category comparison table.

5 CONCLUSIONS

The thesis is focused on Low Power Wide Area Networks. The different technologies used to connect to the Internet of Things such as LoRaWAN, Sigfox and Narrow Band Internet of Things. A simulation of NB-IoT is then made in NS-3 simulator.

The theoretical part describes these different technologies. It compares and contrasts them giving a few examples when one technology is more favourable. This is mostly based on speed, latency and reliability of the technologies in question. An in-depth focus was put on the NB-IoT technology.

Later in the theoretical part, different simulation environments were briefly described. The Network Simulator 3 (NS-3) was described more in-depth. The LENA, which is an integral part of NS-3 is described. This model is specifically meant to simulate LTE networks. But since NB-IoT does not yet have its own model, changes had to be made to LENA towards the implementation of NB-IoT. These changes are the antenna module, the transmit power of the ENodeBs, the frequency and the SRS.

While running the simulation, some of the changes made could either not show the expected results or caused a run error. Taking the tri-sectoral antenna for example, out of the three nodes used to create the antenna, only one participated in transferring packets, and this was usually the one with the least ID (the one that joined first). For this reason, this implementation of antenna was not used in the final simulation.

A network topology for NB-IoT was implemented in NS-3. In the topology, a 500 User Equipment (UE) communicate with a remote host via base stations. The base stations forward the packets that they receive from the UEs to the packet data network gateway (P-GW) and ones from the P-GW to the UEs. This communication is simplified in Fig. 4.1.

The simulations were then carried out in the LENA environment in ns-3 simulator. The output is considered raw at this time. A few more things need to be taken into account to qualify it as an NB-IoT simulation. As mentioned previously, the changes that were not successful (antenna type, UIRbandwidth and UIRearlfcn and the PathLossModel) still need to be fully implemented with real life attribute values. However, some outputs are given in the Apendix. B.

Bibliography

- [1] K. Benson, C. Fracchia, G. Wang, Q. Zhu, S. Almomen, J. Cohn, L. D'arcy, D. Hoffman, M. Makai, J. Stamatakis *et al.*, “Scale: Safe community awareness and alerting leveraging the internet of things,” *IEEE Communications Magazine*, vol. 53, no. 12, pp. 27–34, 2015.
- [2] C. A. F. (CAF), “The internet of things - the next technological revolution,” *Computer*, December 2014. [Online]. Available: http://ec.europa.eu/information_society/newsroom/cf/dae/document.cfm?action=display&doc_id=8606
- [3] R. Ratasuk, N. Mangalvedhe, A. Ghosh, and B. Vejlgaard, “Narrowband lte-m system for m2m communication,” in *Vehicular Technology Conference (VTC Fall), 2014 IEEE 80th*. IEEE, 2014, pp. 1–5.
- [4] V. Petrov, A. Samuylov, V. Begishev, D. Moltchanov, S. Andreev, K. Samouylov, and Y. Koucheryavy, “Vehicle-based relay assistance for opportunistic crowdsensing over narrowband iot (nb-iot),” *IEEE Internet of Things Journal*, 2017.
- [5] M. A. Feki, F. Kawsar, M. Boussard, and L. Trappeniers, “The internet of things: the next technological revolution,” *Computer*, vol. 46, no. 2, pp. 24–25, 2013.
- [6] R. Ratasuk, B. Vejlgaard, N. Mangalvedhe, and A. Ghosh, “Nb-iot system for m2m communication,” in *Wireless Communications and Networking Conference (WCNC), 2016 IEEE*. IEEE, 2016, pp. 1–5.
- [7] R. Ratasuk, N. Mangalvedhe, and A. Ghosh, “Overview of lte enhancements for cellular iot,” in *Personal, Indoor, and Mobile Radio Communications (PIMRC), 2015 IEEE 26th Annual International Symposium on*. IEEE, 2015, pp. 2293–2297.
- [8] Cisco®, “White paper: Cisco visual networking index: Global mobile data traffic forecast update, 2016–2021,” Cisco, Tech. Rep. C11-738429-00 03/17, February 2017. [Online]. Available: <https://www.cisco.com/c/en/us/solutions/collateral/service-provider/visual-networking-index-vni/mobile-white-paper-c11-520862.html>

- [9] S. Dawaliby, A. Bradai, and Y. Pousset, “In depth performance evaluation of lte-m for m2m communications,” in *Wireless and Mobile Computing, Networking and Communications (WiMob), 2016 IEEE 12th International Conference on*. IEEE, 2016, pp. 1–8.
- [10] F. Shrouf, J. Ordieres, and G. Miragliotta, “Smart factories in industry 4.0: A review of the concept and of energy management approached in production based on the internet of things paradigm,” in *Industrial Engineering and Engineering Management (IEEM), 2014 IEEE International Conference on*. IEEE, 2014, pp. 697–701.
- [11] E. U. Ogbodo, D. Dorrell, and A. M. Abu-Mahfouz, “Cognitive radio based sensor network in smart grid: Architectures, applications and communication technologies,” *IEEE Access*, 2017.
- [12] É. Morin, M. Maman, R. Guizzetti, and A. Duda, “Comparison of the device lifetime in wireless networks for the internet of things,” *IEEE Access*, vol. 5, pp. 7097–7114, 2017.
- [13] F. Adelantado, X. Vilajosana, P. Tuset-Peiro, B. Martinez, J. Melia-Segui, and T. Watteyne, “Understanding the limits of lorawan,” *IEEE Communications Magazine*, vol. 55, no. 9, pp. 34–40, 2017.
- [14] J. de Carvalho Silva, J. J. Rodrigues, A. M. Alberti, P. Solic, and A. L. Aquino, “Lorawan—a low power wan protocol for internet of things: A review and opportunities,” in *Computer and Energy Science (SpliTech), 2017 2nd International Multidisciplinary Conference on*. IEEE, 2017, pp. 1–6.
- [15] W. Yang, M. Wang, J. Zhang, J. Zou, M. Hua, T. Xia, and X. You, “Narrow-band wireless access for low-power massive internet of things: A bandwidth perspective,” *IEEE Wireless Communications*, 2017.
- [16] V. Petrov, K. Mikhaylov, D. Moltchanov, S. Andreev, G. Fodor, J. Torsner, H. Yanikomeroglu, M. Juntti, and Y. Koucheryavy, “When iot keeps people in the loop: A path towards a new global utility,” *arXiv preprint arXiv:1703.00541*, 2017.
- [17] R. B. Sørensen, D. M. Kim, J. J. Nielsen, and P. Popovski, “Analysis of latency and mac-layer performance for class a lorawan,” *IEEE Wireless Communications Letters*, 2017.
- [18] J. Petajajarvi, K. Mikhaylov, A. Roivainen, T. Hanninen, and M. Pettissalo, “On the coverage of lpwans: range evaluation and channel attenuation model for

- lora technology,” in *ITS Telecommunications (ITST), 2015 14th International Conference on*. IEEE, 2015, pp. 55–59.
- [19] O. Georgiou and U. Raza, “Low power wide area network analysis: Can lora scale?” *IEEE Wireless Communications Letters*, vol. 6, no. 2, pp. 162–165, 2017.
- [20] Sigfox, “Sigfox technology overview,” 2013, accessed: 01.12.2017. [Online]. Available: <https://www.sigfox.com/en/sigfox-iot-technology-overview>
- [21] sigfox.com, “Sigfox technical overview,” 2017, accessed: 29.04.2018. [Online]. Available: <https://www.disk91.com/wp-content/uploads/2017/05/4967675830228422064.pdf>
- [22] 3GPP, “Design documentation,” July 23, 2015, accessed: 18.02.2018. [Online]. Available: http://www.3gpp.org/news-events/3gpp-news/1714-lc_mtc
- [23] M. Kevin FLYNN and C. O. 3GPP, “Nb-iot enhancements,” 2017, accessed: 19.11.2017. [Online]. Available: http://www.3gpp.org/news-events/3gpp-news/1805-iot_r14
- [24] 3GLTEinfo, “Lte cat 0 for internet of things and m2m,” July 23, 2015, accessed: 18.02.2018. [Online]. Available: <http://www.3glteinfo.com/lte-cat-0/>
- [25] A. Høglund, X. Lin, O. Liberg, A. Behravan, E. A. Yavuz, M. Van Der Zee, Y. Sui, T. Tirronen, A. Ratilainen, and D. Eriksson, “Overview of 3gpp release 14 enhanced nb-iot,” *IEEE Network*, vol. 31, no. 6, pp. 16–22, 2017.
- [26] J. Schliez and D. Raddino, “Narrowband internet of things whitepaper,” *IEEE Microwave Magazine*, vol. 8, no. 1, pp. 76–82, 2016.
- [27] 3GPP, “Etsi ts 136 211 v13.2.0 (2016-8),” July 23, 2015, accessed: 11.03.2018. [Online]. Available: http://www.etsi.org/deliver/etsi_ts/136200_136299/136211/13.02.00_60/ts_136211v130200p.pdf
- [28] R. Ratasuk, N. Mangalvedhe, Y. Zhang, M. Robert, and J.-P. Koskinen, “Overview of narrowband iot in lte rel-13,” in *Standards for Communications and Networking (CSCN), 2016 IEEE Conference on*. IEEE, 2016, pp. 1–7.
- [29] K. Zhou, N. Nikaein, R. Knopp, and C. Bonnet, “Contention based access for machine-type communications over lte,” in *Vehicular Technology Conference (VTC Spring), 2012 IEEE 75th*. IEEE, 2012, pp. 1–5.

- [30] ATT, “What you need to know about iot wide area networks,” 2017, accessed: 29.04.2018. [Online]. Available: https://www.business.att.com/content/whitepaper/what_need_know_iot_networks.pdf
- [31] U. Raza, P. Kulkarni, and M. Sooriyabandara, “Low power wide area networks: An overview,” *IEEE Communications Surveys & Tutorials*, vol. 19, no. 2, pp. 855–873, 2017.
- [32] W. Yang, M. Hua, J. Zhang, T. Xia, J. Zou, C. Jiang, and M. Wang, “Enhanced system acquisition for nb-iot,” *IEEE Access*, vol. 5, pp. 13 179–13 191, 2017.
- [33] S. Landström, J. Bergström, E. Westerberg, and D. Hammarwall, “Nb-iot: A sustainable technology for connecting billions of devices,” *Ericsson Technology Review*, vol. 4, pp. 2–11, 2016.
- [34] P. Rajankumar, P. Nimisha, and P. Kamboj, “A comparative study and simulation of aodv manet routing protocol in ns2 & ns3,” in *Computing for Sustainable Global Development (INDIACom), 2014 International Conference on*. IEEE, 2014, pp. 889–894.
- [35] E. Weingartner, H. Vom Lehn, and K. Wehrle, “A performance comparison of recent network simulators,” in *Communications, 2009. ICC’09. IEEE International Conference on*. IEEE, 2009, pp. 1–5.
- [36] E. Atwater, C. Bocovich, U. Hengartner, and I. Goldberg, “Live lesson: Netsim: Network simulation and hacking for high schoolers,” in *2017 USENIX Workshop on Advances in Security Education (ASE 17)*. Vancouver, BC: USENIX Association, 2017. [Online]. Available: <https://www.usenix.org/conference/ase17/workshop-program/presentation/atwater>
- [37] Wikipedia, “Graphical network simulator-3 (gns-3),” accessed: 23.11.2017. [Online]. Available: https://en.wikipedia.org/wiki/Graphical_Network_Simulator-3
- [38] NS3, “ns-3 tutorial,” 2017, accessed: 29.04.2018. [Online]. Available: <https://www.nsnam.org/docs/release/3.25/tutorial/singlehtml/index.html>
- [39] L. page in CTTC, “Lte-epc network simulator,” 2013, accessed: 23.11.2017. [Online]. Available: <http://networks.cttc.es/mobile-networks/software-tools/lena/>
- [40] NS3, “Overview of the lte-epc simulation model.” November 2017, accessed: 23.11.2017. [Online]. Available: <https://www.nsnam.org/docs/models/ns-3-model-library.pdf#figure.19.1>

- [41] Lteworld.org, “Radio resource control (rrc),” accessed: 23.11.2017. [Online]. Available: <http://lteworld.org/specification/radio-resource-control-rrc>
- [42] P. D. C. P. (PDCP), “Lteworld.org,” accessed: 23.11.2017. [Online]. Available: <http://lteworld.org/specification/packet-data-convergence-protocol-pdcp>
- [43] Lteworld.org, “Packet data convergence protocol (pdcp),” accessed: 23.11.2017. [Online]. Available: <http://lteworld.org/specification/radio-link-control-rlc>
- [44] G. Frédéric Firmin, “The evolved packet core,” accessed: 23.11.2017. [Online]. Available: <http://www.3gpp.org/technologies/keywords-acronyms/100-the-evolved-packet-core>
- [45] J. TechLibrary, “Serving gateway functions overview,” 2013, accessed: 23.11.2017. [Online]. Available: https://www.juniper.net/documentation/en_US/junos-mobility12.1/topics/concept/sgw-mobility-functions-overview.html
- [46] NS-3, “Design documentation,” 2013, accessed: 23.11.2017. [Online]. Available: <https://www.nsnam.org/docs/models/html/lte-design.html>
- [47] M. Propagation, “Models - propagation,” 2017, accessed: 19.03.2018. [Online]. Available: <https://www.nsnam.org/docs/models/html/propagation.html>
- [48] NS-3, “Models - mobility,” 2017, accessed: 19.03.2018. [Online]. Available: <https://www.nsnam.org/docs/models/html/mobility.html>
- [49] NS3, “Models - flow monitor,” 2017, accessed: 19.03.2018. [Online]. Available: <https://www.nsnam.org/docs/models/html/flow-monitor.html#flowmonitor>

List of symbols, physical constants and abbreviations

IoT	Internet of Things
H2H	Human to Human communication
M2M	Machine to Machine communication
UE(s)	User Equipment(s)
LPWA	Low Power Wide Area
LPWAN	Low Power Wide Area Network
NB-IoT	Narrow Band Internet of Things
LoRa	Long Range
LoRaWAN	Long Range Wide Area Network
3GPP	Third Generation Partnership Program
UL	Uplink
DL	Downlink
NS-3	Network Simulator 3
LTE	Long Term Evolution
EPC	Evolved Packet Core
LENA	LTE-EPC Network Simulator (the LTE module in NS-3)
P-GW	Packet Data Gateway
TCP	Transport Control Protocol
UDP	User Datagram Protocol
RFID	Radio Frequency Identifier
WSN	Wireless Sensor Network
ICT	Information and Communications Technology
IP	Internet Protocol
MTC	Machine Type Communication
LTE-M	Long Term Evolution for Machine Type Communication
CPS	Cyber-Physical Space
SCALE	Safe Community Awareness and Alerting Network
CRSN	Cognitive Radio-based Sensor Network
SG	Smart Grid
LTE Cat-1	Long Term Evolution Category One
WAN	Wide Area Network
MAC	Media Access Control
AP	Access Point
GSM	Global System for Mobile
EC-GSM-IoT	Extended Coverage - GSM - Internet of Things

ISM	Industrial, Scientific and Medicine (radio bands)
CSS	Chirps Spread Spectrum
LBT AFA	Listen Before Talk Adaptive Frequency Agility
ADR	Adaptive Data Rate
UNB	Ultra-Narrow Band
SINR	Signal-to-Noise-and-Interference-Ratio
GPS	Global Positioning System
2G	Second Generation
3G	Third Generation
PRB	Physical Resource Block
OTDOA	Observed Time Difference Of Arrival
MMBM	Multimedia Broadcast Messages
SC-PtM	Single Cell Point-to-Multipoint
	SC-PtP Single Cell Point-to-point
	SC-MBMS Single Cell Multicast Broadcast Messages
SC-MCCH	Single Cell Multicast Broadcast Messages Control
QoS	Quality of Service
QoE	Quality of Experience
MCL	Maximum Coupling Loss
IMS	IP Multimedia Subsystems
UTS	Universal Telecommunication Systems
FDD	Frequency Division Multiplexing
TDD	Time Division Multiplexing
CIoT	Cellular Internet of Things
S-GW	Serving Gateway
RAN	Radio Access Network
MME	Mobility Management Entity
SCEF	Service Capability Exposure Function
OFDMA	Orthogonal Frequency-Division Multiplexing
SC-FDMA	Single-Carrier Frequency Division Multiplexing Access
BPSK	Binary Phase Shift Keying
QPSK	Quadrature Phase Shift Keying
NPBCH	Narrowband Physical Broadcast Channel
NPDCCH	Narrowband Physical Downlink control channel
NPDSCH	Narrowband Physical Downlink Shared Channel
NPSS	Narrowband Primary Synchronization Signal
NSSS	Narrowband Secondary Synchronization Signal
PCID	Physical Cell Identifier

NCellID	Narrowband Physical Cell Identifier
NRS	Narrowband Reference Signal
MIB	Master Information Block
MIB-NB	Narrowband Master Information Block
UMTS	Universal Mobile Telecommunication System
UTRA	UMTS Terrestrial Radio Access
UTRAN	UMTS Terrestrial Radio Access Network
E-UTRAN	Enhanced Universal Terrestrial Radio Access Network
eNB or eNodeB	Evolved Node B (E-UTRAN Node B)
SFBC	Space Frequency Block Coding
CRS	Cell Specific Reference Signal
MBSFN	Multicast-broadcast single-frequency network
SF	Single Frequency
LSB	Least Significant Bit
MSB	Most Significant Bit
NPUSCH	Narrowband Physical Uplink Shared Channel
NPRACH	Narrowband Physical Random Access Channel
DMRS	Demodulation Reference Signal
PSD	Power Spectral Density
HARQ	Hybrid Automatic Repeat reQuest
ACK	Acknowledgement
NACK	Negative (no explicit) Acknowledgement
DCI	Downlink Control Information
NDI	New Data Indicator
eMTC	Enhanced Machine Type Communication
PSM	Power Saving Mode
eDRx	Extended Discontinuous Reception
RU	Resource Unit
GNS3	Graphical Network Simulator 3
SON	Self Organized Networks
RRC	Radio Resource Control
NAS	Non-access Stratum
PDCP	Packet Data Convergence Protocol
RLC	Radio Link Control
PHY	Physical Layer
ITU	International Telecommunication Union

List of appendices

A Codes Used	70
A.1 Mobility	70
A.2 SRS	70
A.3 CosineAntennaModel	70
A.4 UEs Random Position Allocation	71
A.5 UDP Protocol code used	71
A.6 TCP Code	72
B QoS	74
B.1 Output for 500 UEs	74
B.2 Control sim for 20 UEs	74
C Content of the CD included	76

A Codes Used

The following are codes used in the text

A.1 Mobility

```
MobilityHelper mobility;
```

```
mobility.SetPositionAllocator ("ns3::GridPositionAllocator",  
"MinX", DoubleValue (0.0),  
"MinY", DoubleValue (0.0),  
"DeltaX", DoubleValue (5.0),  
"DeltaY", DoubleValue (10.0),  
"GridWidth", UIntegerValue (3),  
"LayoutType", StringValue ("RowFirst"));
```

A.2 SRS

```
void  
LteEnbNetDevice::SetUllBandwidth (uint8_t bw)  
{ NS_LOG_FUNCTION (this << uint16_t (bw));  
  switch (bw)  
  {  
    case 6:  
    case 15:  
    case 25:  
    case 50:  
    case 75:  
    case 100:  
      m_ulBandwidth = bw;  
      break;  
  
    default:  
      NS_FATAL_ERROR ("invalid bandwidth value" << (uint16_t)  
        bw);  
      break;  
  }  
}
```

A.3 CosineAntennaModel

```

lteHelper->SetAntennaModelType("ns3::CosineAntennaModel");
lteHelper->SetAntennaModelAttribute("Orientation",
    DoubleValue(240)); //120 deg for example. Could be 120 or 240
lteHelper->SetAntennaModelAttribute("Beamwidth",
    DoubleValue(120));
lteHelper->SetAntennaModelAttribute("UIBandwidth",
    DoubleValue(20));
enbDev.Add(lteHelper->InstallEnbDevice(enbNodes))

```

A.4 UEs Random Position Allocation

```

MobilityHelper mobilityUes;
mobilityUes.SetMobilityModel("ns3::ConstantPositionMobilityModel");
mobilityUes.SetPositionAllocator("RandomBoxPositionAllocator",
    "X",
    StringValue("ns3::UniformRandomVariable [min=25.0|Max=200.0]"),
    "Y",
    StringValue("ns3::UniformRandomVariable [min=75.0|Max=250.0]"),
    "Z", StringValue("ns3::UniformRandomVariable [min=1|Max=1]"));
mobilityUes.Install(ueNodes);

```

A.5 UDP Protocol code used

```

//code used to generate the UDP traffic
for (int u = 0; u < numberOfUes/2; ++u)
{
Ptr<Node> ue = ueNodes.Get (u);
// Set the default gateway for the UE
Ptr<Ipv4StaticRouting> ueStaticRouting =
    ipv4RoutingHelper.GetStaticRouting (ue->GetObject<Ipv4> ());
ueStaticRouting->SetDefaultRoute
    (epcHelper->GetUeDefaultGatewayAddress (), 1);

for (int b = 0; b < numBearersPerUe; ++b)
{
++dlPort;
++ulPort;

ApplicationContainer clientApps;
ApplicationContainer serverApps;

```

```

NS_LOG_LOGIC ("installing_UDP_DL_app_for_UE" << u);
UdpClientHelper dlClientHelper (ueIpInterfaces.GetAddress (u),
    dlPort);
dlClientHelper.SetAttribute ("Interval", TimeValue
    (Milliseconds(30)));
dlClientHelper.SetAttribute ("MaxPackets",
    UIntegerValue(100000000));
dlClientHelper.SetAttribute ("PacketSize", UIntegerValue
    (maxpacksize));

clientApps.Add (dlClientHelper.Install (remoteHost));
PacketSinkHelper dlPacketSinkHelper ("ns3::UdpSocketFactory",
    InetSocketAddress (Ipv4Address::GetAny (), dlPort));
serverApps.Add (dlPacketSinkHelper.Install (ue));

NS_LOG_LOGIC ("installing_UDP_UL_app_for_UE" << u);
UdpClientHelper ulClientHelper (remoteHostAddr, ulPort);
clientApps.Add (ulClientHelper.Install (ue));
PacketSinkHelper ulPacketSinkHelper ("ns3::UdpSocketFactory",
    InetSocketAddress (Ipv4Address::GetAny (), ulPort));
serverApps.Add (ulPacketSinkHelper.Install (remoteHost));

Time startTime = Seconds (startTimeSeconds->GetValue ());
serverApps.Start (startTime);
clientApps.Start (startTime);

}
}

```

A.6 TCP Code

```

for (int u = numberOfUes/2; u < numberOfUes; ++u)
{
    Ptr<Node> ue = ueNodes.Get (u);
    // Set the default gateway for the UE
    Ptr<Ipv4StaticRouting> ueStaticRouting =
        ipv4RoutingHelper.GetStaticRouting (ue->GetObject<Ipv4>
            ());
    ueStaticRouting->SetDefaultRoute

```

```

        (epcHelper->GetUeDefaultGatewayAddress (), 1);

for (int b = 0; b < numBearersPerUe; ++b)
{
    ++dlPort;
    ++ulPort;

    ApplicationContainer TCPclientApps;
    ApplicationContainer TCPserverApps;

    NS_LOG_LOGIC ("installing TCP_DL_app for UE" << u);
    OnOffHelper onoff ("ns3::TcpSocketFactory", Address
        (InetSocketAddress (ueIpIfaces.GetAddress (u), dlPort)));
    onoff.SetConstantRate (DataRate ("480kb/s"));
    onoff.SetAttribute ("PacketSize", UintegerValue
        (maxpacksize));
    onoff.SetAttribute ("Remote", AddressValue
        (InetSocketAddress (remoteHostAddr, ulPort)));
    PacketSinkHelper sink ("ns3::TcpSocketFactory", Address
        (InetSocketAddress (ueIpIfaces.GetAddress (u), ulPort)));

    TCPclientApps = onoff.Install(ue);

    TCPserverApps = onoff.Install(remoteHost);
    TCPclientApps = onoff.Install(ue);

    ApplicationContainer apps = onoff.Install (enbNodes);
    apps = sink.Install (enbNodes);

    Time startTime = Seconds (startTimeSeconds->GetValue ());
    TCPclientApps.Start (startTime);
    TCPserverApps.Start (startTime);
}
}

```

B QoS

B.1 Output for 500 UEs

```
Flow ID: 1451 Src Addr 1.0.0.2 Dst Addr 7.0.0.64
Tx Packets = 67
Tx Bytes = 70484
Sum jitter = +944000000.0ns
Delay Sum = +1120497406.0ns
Rx Bytes = 2104
Rx Packets = 2
Throughput: 11.5574 Kbps
Packet loss %= 97.0149
Flow ID: 1452 Src Addr 7.0.0.83 Dst Addr 1.0.0.2
Tx Packets = 200
Tx Bytes = 210400
Sum jitter = +0.0ns
Delay Sum = +39178120.0ns
Rx Bytes = 1052
Rx Packets = 1
Throughput: 138.882 Kbps
Packet loss %= 99.5
Flow ID: 1453 Src Addr 1.0.0.2 Dst Addr 7.0.0.83
Tx Packets = 67
Tx Bytes = 70484
Sum jitter = +959000000.0ns
Delay Sum = +10438724616.0ns
Rx Bytes = 19988
Rx Packets = 19
Throughput: 79.4588 Kbps
Packet loss %= 71.6418
```

Fig. B.1: 500 UEs

B.2 Control sim for 20 UEs

```
Flow ID: 44 Src Addr 7.0.0.11 Dst Addr 1.0.0.2
Tx Packets = 200
Tx Bytes = 210400
Sum jitter = +2903823250.0ns
Delay Sum = +17373443767.0ns
Rx Bytes = 162008
Rx Packets = 154
Throughput: 637.923 Kbps
Packet loss %= 23
Flow ID: 45 Src Addr 1.0.0.2 Dst Addr 7.0.0.11
Tx Packets = 67
Tx Bytes = 70484
Sum jitter = +1659000000.0ns
Delay Sum = +3735078416.0ns
Rx Bytes = 50496
Rx Packets = 48
Throughput: 206.745 Kbps
Packet loss %= 28.3582
```

Fig. B.2: 20 UEs.

C Content of the CD included

The following is the content of the included disc. The version of the NS-3 simulator used was NS-3 version 3.27.

```
/ ..... CD root address
├── loga ..... logos of the school and faculty
│   ├── BUT_abbreviation_color_PANTONE_EN.pdf
│   ├── BUT_color_PANTONE_EN.pdf
│   ├── FEEC_abbreviation_color_PANTONE_EN.pdf
│   ├── FEKT_zkratka_barevne_PANTONE_CZ.pdf
│   ├── logolink-op_vavpi.png
│   ├── SIX_logo_zahlavi.png
│   ├── UTKO_color_PANTONE_CZ.pdf
│   ├── UTKO_color_PANTONE_EN.pdf
│   ├── VUT_barevne_PANTONE_CZ.pdf
│   ├── VUT_symbol_barevne_PANTONE_CZ.pdf
│   └── VUT_zkratka_barevne_PANTONE_CZ.pdf
├── obrazky ..... other images
│   ├── NB-IoT ..... NB-IoT Images
│   │   ├── frame.pdf
│   │   ├── map.pdf
│   │   ├── map_dl.pdf
│   │   ├── mapping.pdf
│   │   ├── sleep.pdf
│   │   ├── slot.pdf
│   │   └── slots.pdf
│   ├── SIGFOX ..... Sigfox Images
│   │   ├── ARCH.pdf
│   │   ├── ARCH1.pdf
│   │   ├── FlatArch.pdf
│   │   ├── FlatArch1.pdf
│   │   ├── io.pdf
│   │   ├── ISM-Band.pdf
│   │   └── UNB.pdf
│   ├── vysledky ..... Images from the simulations
│   │   ├── error0.jpg
│   │   ├── output_20UEs.jpg
│   │   ├── sim_para.pdf
│   │   ├── topo.pdf
│   │   └── topology.pdf
│   ├── CIoT-Optimization.pdf
│   ├── cisco.pdf
│   ├── industry4.pdf
│   ├── industry42.pdf
│   ├── LoRa1.png
│   └── lpwan2.png
```

```

|
|_ lpwancomp.png
|_ LPWAN-comparison.pdf
|_ LTE.pdf
|_ LTE-EPC.pdf
|_ LTE-M-Network-architecture.pdf
|_ LTE-M-releases.pdf
|_ LTEscene.pdf
|_ LTEscene2.pdf
|_ LTE-simplified.pdf
|_ nbiot1.pdf
|_ nbiot2.pdf
|_ nbiot3.pdf
|_ NB-IoT-Airinterface.pdf
pdf ..... pdf pages generated by the Information System
|_ student-desky.pdf
|_ student-titulka.pdf
|_ student-zadani.pdf
text ..... source tex files
|_ extendedabstract.tex
|_ prilohy.tex
|_ References.tex
|_ reseni.tex
|_ uvod.tex
|_ vysledky.tex
|_ zaver.tex
|_ zkratky.tex
NB-IoT.cc ..... NS-3 file for the simulation
readme.txt ..... readme file
sablona-prace.tex ..... main file
thesis.sty ..... thesis package
variable.tex ..... contains variables

```